

Effect of vacuum desalination on heat exchange parameters

Anton Kovalyov¹, Nelina Krokhalova^{2,*}, and Kseniya Savvateeva¹

¹South Ural State University, Polytechnic Institute, Electric Power Generation Stations, Networks and Supply Systems Department, 454080 Chelyabinsk, Russia

²South Ural State University, Polytechnic Institute, Heat Power Engineering Department, 454080 Chelyabinsk, Russia

Abstract. On the example of a thermal scheme of a waste-distillation vacuum desalination plant, it is considered how the heat exchange parameters change depending on the time of year and the region of navigation of the vessel or the location of the plant. The performance of the desalination plant depends on the performance of the engine and the temperature of the sea water, since the main engine is cooled by sea water, which in turn is used to heat the heating battery in the desalination plant. In this thermal scheme, water is heated in a heat exchanger, the characteristics of which can be selected the same as those of the main engine of the vessel.

1 Introduction

At the moment, in many areas of human activity, there is a shortage of fresh water. In order to provide fresh water to small towns, villages, factories and plants in areas that are located on the shores of the seas, various types of desalination plants are used. They are also used on ships on the high seas, since it is almost impossible to take the necessary fresh water supplies in the required quantities with you. One such desalination plant is the Type «D» desalination plant. This desalination plant is similar in design to the Danish block vacuum desalination plant Atlas, which uses heat from a diesel fuel cooling system and operates on a similar cycle. Such an installation is capable of producing 600 - 1200 liters of clean water per hour per 1000 kW of power, depending on the type of engine. For most vessels, these characteristics fully cover all fresh water needs.

Type «D» vacuum desalination plant is a Russian deep vacuum utilizing boiling desalination plant. Thanks to this desalination plant, supplies of drinking, technical and distilled water are replenished on transport ships. This unit operates at constant pressure and can produce up to 25 tons of pure water per day. Water desalination plants of this type are currently widely used on transport ships. The heat-exchange part of the heating battery consists of vertically installed cupronickel tubes, flared in brass tube plates, in which the process of boiling sea water takes place. The steam from these tubes is fed into the evaporation chamber, from where the louvered separator then enters, and then the steam enters the condenser. Due to the action of centrifugal forces, when the direction of movement

* Corresponding author: pte2017pte@mail.ru

of the steam-water mixture changes, the separation of brine drops occurs, that is, the separation of droplet moisture. The louvered separator and the large height of the steam space of this unit allow you to get clean water with a low level of salinity [1, 2].

Part of the intake water that is pumped through the condenser is fed to the evaporator, while the other part is used in the water jet ejector as a working fluid. The ejector is designed to blow brine out of the heat exchanger overboard. Due to the condensation of steam in the condenser, the working vacuum is maintained in the desalination plant. The vacuum parameters in the installation directly depend on the temperature of the cooling water; thus, the lower the temperature of the cooling water, the closer the pressure approaches vacuum. Cooling water with a temperature of 60 - 80 °C is supplied from the main engine of the ship, it is used as a heat source in the evaporator heating battery. To improve the heat transfer parameters in the heating battery of the evaporator is organized. The speed of the heating water depends on the design of the desalination machine - the lower the hydraulic resistance of water flows, the higher the speed. Before clean water enters the tank, it enters a special water desalination collector, where special samples are taken for water salinity, if this value does not exceed the norm; the water enters the water collection tank [3, 4].

This type of water desalination plant is fully automated and does not involve human work. Data such as condenser inlet and outlet cooling water temperature, evaporator inlet and outlet heating water temperature, evaporator vacuum, and feed water flow and water salinity are digitally monitored [5, 6]. Water desalination plants are delivered to the market in a complete set: on a common frame and equipment that is absolutely necessary for maintenance, as well as devices [3, 4, 7].

2 Materials and methods. The principle of operation of the technological scheme. Scientific novelty

The thermal scheme in figure 1 consists of a desalination machine, a heat exchanger and a water collection tank, as well as various pipelines through which the working fluid circulates [8, 9]. Unlike the initial data, we use an electric heat exchanger, where the heating water is heated. The water heated in this heat exchanger is close in characteristics to the water that cools the main engine of the ship [10]. This thermal scheme is good because it can be used not only on ships on the high seas, but also on land. The desalination machine uses a boiling (adiabatic) method of evaporating sea water, due to which water at very low pressure instantly turns into steam, from where it then goes to other components of the desalination plant. The water collection tank is a conventional cistern [11, 12].

Formula for finding the productivity of a desalination plant:

$$G = \frac{Q}{(1 + \omega) \cdot C \cdot (t_{med} - t_1') + r} \quad (1)$$

where Q – the thermal power for heating or evaporating water; ω – the blowing coefficient; C – the heat capacity of the feed water (reference data); r – the specific heat of vaporization; t – the average temperature of the secondary steam; t_1' – sea water temperature leaving the desalination plant condenser [5, 13, 14].

Formula for finding the average temperature of the heating water:

$$t_{med} = \frac{t' - t''}{2} \quad (2)$$

where t' – heating water temperature; t'' – heating water temperature at the outlet of the heat exchanger.

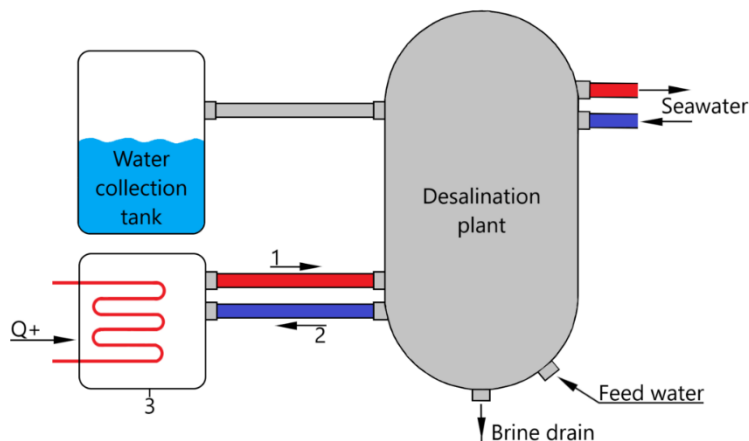

Fig. 1. Installation diagram: 1 – heating water supply; 2 – heating water outlet; 3 – heat exchanger.

The formula for finding the temperature of the heating water at the outlet of the heat exchanger:

$$t'' = t' - \delta \tag{3}$$

where t' – heating water temperature (specified by the conditions of the problem); δ – the decrease in the temperature of the heating water, for this type of distiller it is taken equal to 8...10 °C.

3 Results. Practical significance

The temperature of the heating water at the inlet to the utilization desalination plant is equal to the temperature of the water cooling the main engine of the ship, and therefore the temperature of the heating water directly depends on the type of engine used. The heat that comes from the heat exchanger is not fully used, but only partially. From this it follows that the performance is characterized not by the consumption of heat, but by the consumption of electricity, which is spent on the drive of the pumps, due to which the water circulates in the installation. On the surface of the seas and oceans, the annual temperature fluctuation in the tropics does not exceed 5 °C and 10-15 ° in the temperate and arctic zones. From this it follows that during the operation of the desalination plant, the temperature of the outboard water may vary depending on the region of navigation and the time of year. This indicator is also important to take into account when designing a desalination plant, since the temperature of the outboard water affects many characteristics of the desalination machine associated with both steam cooling in the condenser and water heating in the heat exchanger [15, 16].

The productivity of a desalination machine is how much fresh water it can produce in 1 hour. According to sanitary standards, the productivity of a desalination machine should be 1.5–2 times higher than the daily water consumption. The desalination plant is selected depending on how much fresh water is needed for an enterprise, a residential village or a ship. Productivity directly affects the cost of the finished product [6, 7, 17].

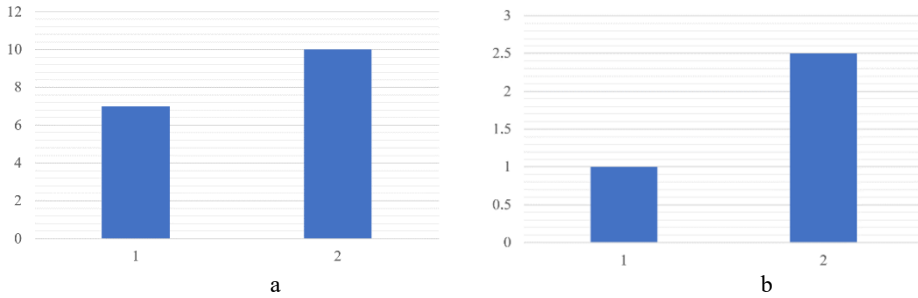

Fig. 2. Comparison of recycling desalination machines: *a* – heating water consumption; *b* – productivity; 1 – heating water temperature at the evaporator inlet is 60 °C; 2 – heating water temperature at the evaporator inlet is 80 °C.

4 Discussion

The prospects for the use of a desalination vacuum plant of the «D» type are that it is fully automated, in other words, this unit is brought in the form of an installation on a common frame, with its own service devices and parts - all this is convenience and practicality in production. Also, the entire mode of operation is carried out under the control of special devices, such as thermometers - they measure the temperature of the heating water both at the inlet and outlet of the evaporator, and at the outlet of the condenser [18]. According to the vacuum gauge - this is a pressure gauge under vacuum, designed to measure the pressure of rarefied gases, while vacuum control is carried out in a water desalination plant of the «D» type. The device belongs to the vacuum desalination of distilled water and can be used for desalination and disinfection of water that is unsuitable for consumption [19, 20].

The vacuum brine desalination method includes hydrostatic pumping of the boiling and condensation chambers, boiling the brine in the boiling chamber, condensing water vapor in the condensation chamber, and removing accumulated non-condensable gases. In hydrostatic pumping, the boiling and condensing chambers are filled with brine and fresh water, respectively. They are separated from the cavity. Brine boiling is accomplished by periodically replenishing the boiling chamber with brine until the salt concentration reaches the saturation point or until the total pressure of non-condensable gases and saturated water vapor reaches a limit [21, 22]. Then the voids are separated.

Non-condensable gases are removed from the boiling and condensing chambers with brine and fresh water, respectively. The boiling chamber is connected to the atmosphere when the concentrated brine is released. The brine desalination plant consists of a boiling chamber and a condensing chamber connected by steam lines to a brine and fresh water network. Control valves are installed on the steam pipeline and on the drain between the boiling and condensing chambers. Effect: invention makes it possible to significantly reduce the ingress of non-condensable gases into the boiler space and to reduce the depth required to drain the brine supplied to the desalination process.

The following types of pumping equipment are used to create a vacuum: screw vacuum pumps; rotary-slotted vacuum pumps; molecular turbo pumps. On average, the vacuum reaches a pressure of 133.3 Pa to 0.1333 Pa, but there is still a high vacuum that creates a pressure of 0.099 Pa to Pa, and there is also an ultra-high vacuum whose pressure exceeds Pa. Screw pumps are devices that, according to the principle of operation, can be divided into two types: oil and oil-free (dry) pumps. The first type refers to low vacuum, and the second to pre-vacuum, then rotary screw pumps are used both for compressing and diluting gases, that is, as vacuum rotary pumps. Pre-vacuum pumps have some design differences and are used in combination with diffusion and molecular pumps, and turbo molecular pumps are a

type of vacuum pumps similar in appearance to turbo pumps and are used to create and maintain a high vacuum. These pumps work on the principle that gas molecules can be pushed in the right direction by hitting a moving solid surface repeatedly.

The basic principle of operation of all types of vacuum pumps is displacement. This is true for vacuum pumps of all sizes and applications. In other words, the principle of operation of a vacuum pump is to remove a mixture of gas, steam or air from the working chamber. When evacuated, the pressure changes, and the gas molecules move in the right direction. Two important conditions that the pump must satisfy are the creation of a vacuum at a certain depth by pumping the gaseous medium from the required space and this condition for a certain time. If one of these conditions cannot be met, an additional vacuum pump must be installed. Therefore, if the required pressure cannot be reached, but within the required time, a pre-vacuum pump is switched on [8, 9].

The vacuum pump additionally reduces the pressure so that all the necessary conditions are met. The principle of operation of a vacuum pump is similar to that of a series connection. Conversely, if the required vacuum cannot be reached when the required pump speed is reached, then another pump is required to achieve the required vacuum more quickly [10]. The working principle of this vacuum pump is similar to that of parallel connection. The depth of vacuum created by a vacuum pump depends on the degree of sealing of the working area created by the pump components. To ensure good sealing of the working area, special oils are used [11]. This seals the gaps and ensures a perfect seal. Vacuum pumps with this design and operating principle are known as oil pumps. If no oil is used in the principle of operation of the vacuum pump, it is called a dry pump. Dry vacuum pumps are advantageous because they do not require oil changes or other maintenance [12].

5 Conclusion

Vacuum explanatory installations are used in areas where there is no access to fresh water. In this paper, a thermal scheme was considered, where heating water is obtained by forced heating of it by a heat exchanger, and not already heated water from the cooling of the main engine. Such a thermal scheme can be applied where there is access to electrical energy, but there is no access to thermal resources. Thanks to this thermal diagram, you can make theoretical calculations of some parameters of the heat exchange process and choose the most suitable desalination plant for yourself, which will meet your needs for drinking and industrial water.

The study was supported by the Russian Science Foundation grant No. 22-19-20011, <https://rscf.ru/en/project/22-19-20011/>

References

1. P. Huang, Y. Sun, D. Gu, W. Yan, *Frontiers in Environmental Science* **10**, 842253 (2022)
2. P. Youssef, R. K. AL-Dadah, S. Mahmoud, *Energy Procedia* **61**, 2604-2607 (2014)
3. D. Krizak, M. Abbaszadeh, S. Kundu, *Separation Science and Technology* **57(7)**, 1-9 (2021)
4. M. Abdunnabi, A. Ramadan, *OAmg*, **4**, 50-51, (2021)
5. A. M. Te, *Thermal and hydraulic calculation of the ship's water desalination plant type «D»* (Russia, 2013)

6. F. Dargam, E. Perz, S. Bergmann, E. Rodionova, *Supporting operational decisions on desalination plants from process modelling and simulation to monitoring and automated control with machine learning* (Spain, 2020)
7. Y. Nian, Z. Deng, W. Cheng, *Desalination* **542**, 116056 (2022)
8. M. Al-Muylaba, A. A. Dayem, *Journal of Engineering and Thermal Sciences*, **2(1)**, 27-45 (2022)
9. S. Choi, *Desalination* **398**, 64-76 (2016)
10. Q. Alsahy, S. S. Ibrahim, S. R. Chemical, Engineering and Processing - Process Intensification **120**, 68-80 (2017)
11. A. N. Shishkov, K. V. Osintsev, *Proceedings of IOP Conf. Ser.: Mater. Sci. Eng.* **1064**, 012032 (2020)
12. A. S. Sedlov, *Thermal power engineering* **4**, 54-60 (2005)
13. O. Ostapenko, V. Leshchenko, R. Tikhonenko, *VNTU* **2**, 12-16 (2015)
14. V. Chernyshova, *Proceedings of International Scientific Conference* (Kazan, 2020)
15. S. L. Elistratov, *Comprehensive study of the efficiency of heat pumps. PhD Thesis* (Novosibirsk, 2011)
16. E. Rudneva, *Problems of effective use of the scientific potential of society* **2**, 146-151 (2021)
17. V. Karankevich, A. Taranchuk, *VNTU* **3**, 14-17 (2018)
18. M. Svalova, E. Koltsov, *Modern science: current issues, achievements and innovations: collection of scientific papers* **4**, 70-77 (2019)
19. G. Zeiser, *Young thought: science, technology, innovation* **4**, 179-182 (2015)
20. I. Loshkarev, D. Odruzov, *Actual problems of agricultural energy* **2**, 110-111 (2018)
21. S. Luneva, *Technical and technological problems of service* **3(33)**, 59-62 (2015)
22. O. A. M. Almokhammed, N. F. Timerbaev, I. Y. Mazarov, *Bulletin of the Kazan State Power Engineering University* **3(43)**, 57-66 (2019)