

Swarthmore College

## Works

---

Senior Theses, Projects, and Awards

Student Scholarship

---

Spring 2023

### Active Noise Cancellation: Analog Circuit

Uladzislau Hes , '23

Follow this and additional works at: <https://works.swarthmore.edu/theses>



Part of the [Engineering Commons](#)

---

#### Recommended Citation

Hes, Uladzislau , '23, "Active Noise Cancellation: Analog Circuit" (2023). *Senior Theses, Projects, and Awards*. 284.

<https://works.swarthmore.edu/theses/284>

This work is brought to you for free by Swarthmore College Libraries' Works. It has been accepted for inclusion in Senior Theses, Projects, and Awards by an authorized administrator of Works. For more information, please contact [myworks@swarthmore.edu](mailto:myworks@swarthmore.edu).

# **Active Noise Cancellation: Analog Circuit**

Uladzislau Hes

Supervisor: Professor Maggie Delano

Swarthmore College

May 2023

## Table of contents:

Abstract	2
Introduction	3
Project Scope	7
Circuit Design	8
Testing Methods	14
Results	18
Discussion	23
Constraints and Requirements	26
Conclusion	27
Acknowledgments	28
References	29
Appendix	30

## **Abstract**

Active Noise Cancellation (ANC) is a technology used in many commercial and professional products, one of which are ANC headphones that provide a listener with the comfort of attenuation of ambient noise. ANC is possible due to the wave interference phenomenon and is implemented using a combination of analog circuitry and digital algorithms in commercial headphones. The aim of this project was to explore the possibility of successfully implementing ANC using only analog circuitry. This project concludes that it is possible to implement Active Noise Cancellation using analog circuitry, but such implementation introduces a trade-off between which frequencies one desires to cancel the most. This project also touches on the importance of using a microphone in the ANC circuit that can pick up the noise from a distance and does not introduce much electrical noise to the signal. The circuit that includes a microphone and a pre-amplifier provided 1-4 dB of cancellation in the 80-200 Hz frequency range, little to no cancellation in the 200-500 Hz frequency range, and some noise amplification in the 500-1000 Hz range. The waveform generator fed circuit without a microphone provided over 5 dB of noise cancellation in the 80-120 Hz range, with the highest being 14 dB at 100 Hz. It also provided over 3 dB of noise cancellation in the 120-800 Hz range with some outlying frequencies, and some ambient noise amplification in the 800-1000 Hz range. The results show the possibility of implementing ANC using analog circuitry only, however they also show the trade-offs introduced from the decision to use analog circuitry only.

## Introduction

Active Noise Cancellation (ANC) has been getting more popular among the general public, since using headphones with ANC provides better listening experience in noisy environments, such as on a train, on a plane, or while walking in a city. Moreover, as we've seen schools and employers shift to virtual, work/study from home models due to COVID, it was important for consumers to have the best ANC implementations in their headphones to help them focus in a potentially loud environment.

Active Noise Cancellation is possible due to a physics principle called destructive interference. When two waves superimpose with each other with exactly opposite phases, or a phase difference of 180 degrees, the amplitude of the resultant force is equal to the difference between the amplitudes of the two waves. ANC headphones have microphones on the inside or the outside of the ear cup that pick up the ambient noise waves. The circuitry then processes the original ambient noise wave to invert it at 180 degrees out of phase and feeds that generated wave with the music being played into the headphones speaker. That way, the noise wave and the generated "anti-noise" wave reach the ear of the listener at the same time, leading to destructive interference and reduction of the original noise wave.

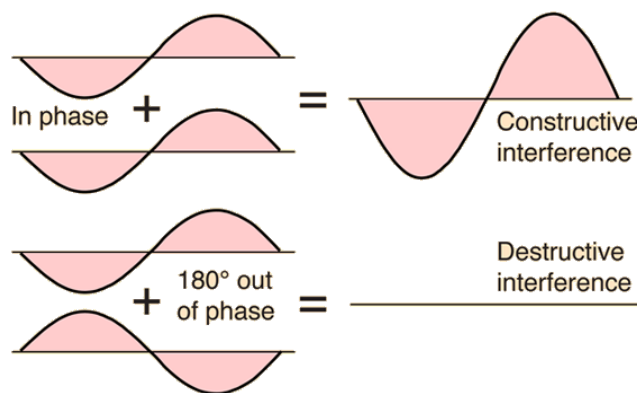

Figure 1 - Wave interference schematic  
(<http://hyperphysics.phy-astr.gsu.edu/hbase/Sound/interf.html>)

There are three main ANC technologies implemented today, each with their own benefits and shortcomings: Feed-forward, Feedback and Hybrid ANC.

In the implementation of Feed-forward ANC, the microphone is placed on the outside of the headset. The ambient noise is picked up by the microphone and is then processed using circuitry or digital signal processing to invert the phase of the noise, amplify the inverted signal, and feed it together with the music into the speaker.

In the implementation of Feedback ANC, the microphones are placed inside the ear cups and pick up the music & noise mix. The circuitry and a digital signal processing algorithm are then used to separate the music and noise sound, and the same principle is used to feed the noise canceling signal into the speaker together with the music as in the feed-forward system.

Hybrid ANC combines feed-forward and feedback ANC by placing the microphones both on the inside and the outside of the earcup. This technique is used in the most expensive, top-notch ANC headphones on the current market.

Below is the table listing some advantages and disadvantages of each ANC technique.

Table 1 - Advantages and disadvantages of ANC techniques

	ANC technique		
	Feed-forward	Feedback	Hybrid
Advantages	does not require much battery power, can be implemented without digital signal processing, less prone to distortion due to its simplicity	deals well with sharp sounds and wind noise, corrects the anti-noise signal it produces	best noise-cancellation out of the three techniques, cancels noise at a broader range of frequencies
Disadvantages	does not self-correct, sensitive to wind noise, the direction of noise cancellation is limited by the quantity and location of microphones	risks of feedback noise, separating noise and music may mean accidentally canceling some lower frequency parts of the music thinking it is noise	more expensive than other techniques, requires well-calibrated algorithms, prone to feedback noise

The ANC technology implemented in this project is Feed-forward. In the implementation of this technique, the microphone is placed on the outside of the headset. The ambient noise is picked up by the microphone and is then processed using circuitry and/or digital signal processing to invert the phase of the ambient noise, amplify the inverted ambient noise, and feed it together with the music into the speaker. The schematic for this technology can be seen in the figure below.

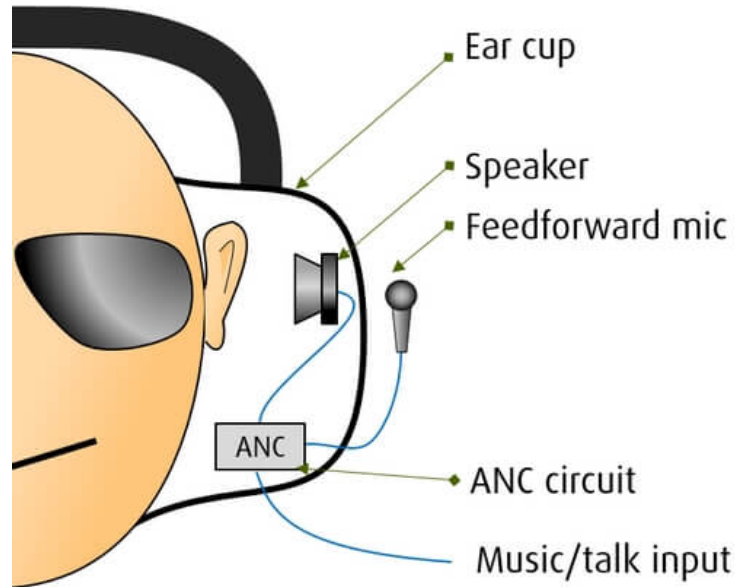

Figure 2 - Feedforward ANC schematic

(<https://www.jabra.com/blog/anc-headsets-arent-all-the-same-three-types-of-anc/>)

One of the advantages of such technology is that it can be implemented without digital signal processing, using analog circuitry only. The disadvantages include the lack of self-correction, as well as a more sensitive setup, which requires trade-off decisions about which frequencies are preferred to be canceled. This technology was picked due to the fact that it can be designed in a fully analog manner, which is the area of my interest.



## **Project Scope**

The first step of this project was to design an analog ANC circuit on the breadboard by examining the behavior of different parts of the circuit with specific values of resistors and capacitors. Then, it was planned to move on to designing a Printed Circuit Board (PCB) using the circuit parts' values established in the previous stage. The next step was to assemble two PCBs, one for each ear, and attach them to a pair of headphones. This final design was to be tested against the certain requirements, such as the amount of noise cancellation in the frequency range of 60-1000 Hz, as well as the power consumption of the circuit.

However, due to the difficulties faced when working on the circuit design on the breadboard, this project ended up being a more in-depth exploration of different design choices, such as including a microphone and a pre-amplifier in the circuit, and the implications of those choices on the performance of the circuit. The circuit went through two iterations which were tested both subjectively, by listening to it, and objectively, by measuring the amount of noise cancellation using a sensitive microphone.

## Circuit Design

### Reference Circuit Design

The starting point for this circuit design was borrowed from an existing online project listed in the references. The block diagram of the circuit is shown in the figure below.

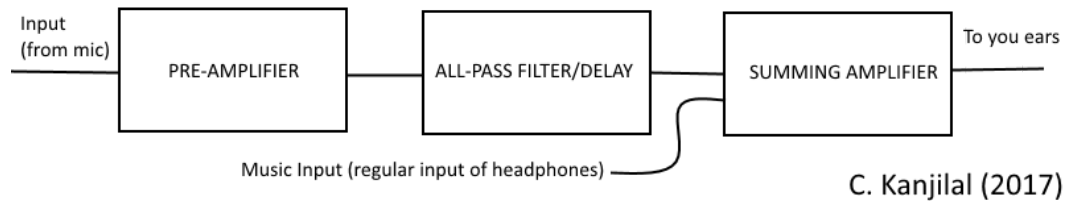

Figure 3 - Block diagram of the reference circuit

([https://phys420.phas.ubc.ca/p420\\_16/bartok1/sound\\_project.html](https://phys420.phas.ubc.ca/p420_16/bartok1/sound_project.html))

The block diagram above can be implemented as a circuit using op-amps, resistors and capacitors. The reference circuit design is shown in the figure below. Although the reference circuit design diagram includes a microphone and a speaker in it, those elements were not included in the constructed circuit. The main purpose of constructing this circuit was to test the performance of the op-amp blocks, which make up this circuit. This design was modified throughout the process of this project to accommodate for the roadblocks encountered. The designs in this section were implemented on a breadboard.

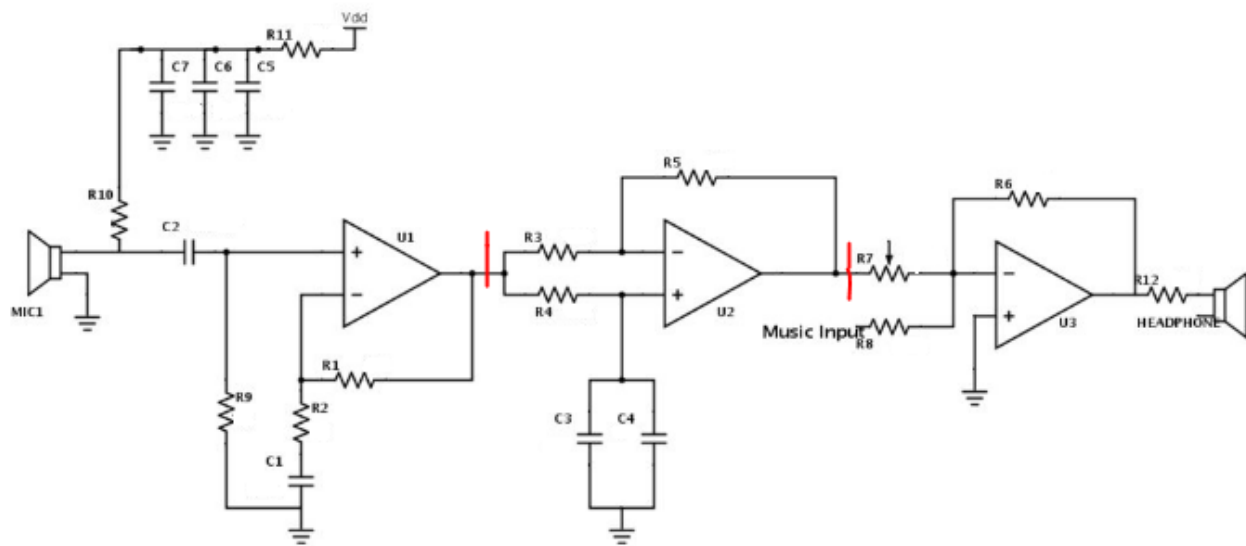

Figure 4 - The reference circuit design

([https://phys420.phas.ubc.ca/p420\\_16/bartok1/sound\\_project.html](https://phys420.phas.ubc.ca/p420_16/bartok1/sound_project.html))

The top left part of the circuit consisting of R11, C5, C6 and C7 is a low pass filter for the voltage source for the circuit. It is needed to exclude any high frequency noise from the voltage supply.

For this project, an electret microphone was used, which requires voltage to operate. R10 acts as a pull-up resistor for the microphone, whereas C2 is an AC coupling capacitor which blocks any DC voltage in the microphone's output. A diagram of a conventional electret microphone circuit is shown below.

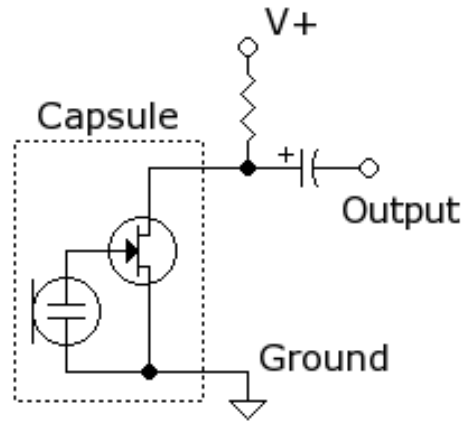

Figure 5 - A typical electret microphone circuit

([https://en.wikipedia.org/wiki/Electret\\_microphone](https://en.wikipedia.org/wiki/Electret_microphone))

The first part of the circuit is a non-inverting op-amp (U1) that serves the purpose of a pre-amplifier for the microphone signal. The gain of the preamplifier is determined by the ratio between R1 and R2, specifically  $G = 1 + R1/R2$ . C1 and R9 are used to once again eliminate the DC part of the signal, as well as to deal with voltage errors from input bias current.

The next part of the circuit is an all-pass unity gain op-amp (U2) with a phase delay. The delay is needed due to the difference in time it takes for the ambient noise waves to travel to one's ears and the anti-noise signal to travel through the circuitry and then to the ear. The anti-noise signal travels the distance from the microphone to the speaker much faster than the original ambient noise travels that distance, thus the anti-noise signal needs to be delayed to have the ambient noise and the anti-noise signals arrive to the listener's ear at the same time. This part of the circuit is crucial for the noise-canceling to work due to the fact that if the ambient noise and anti-noise waves arrive to the listener's ear with the slightest offset, the attenuation of the original ambient noise might be bad or the antinoise will magnify the original noise instead of canceling it.

The next part of the circuit is an inverting and summing op-amp (U3). This part of the circuit sums the anti-noise signal with the music and then inverts both of those signals. The inversion of the music does not matter, however, the inversion of the anti-noise signal makes it ~180 degrees out of phase from the original ambient noise signal, which is the main goal of this circuit. The gain of the music input is  $G = R6/R8$ . The gain of the anti-noise signal is  $G = R7/R8$ . A potentiometer is used for R7 to control the magnitude of the anti-noise signal to tune it for the best performance.

R12 is used to control the current going into the headphones to ensure the volume is not too higher than 85 dB for the listener.

### Mic & Headphones Circuit

The next circuit iteration includes a microphone and a speaker in it, as the main purpose of this circuit was to test the overall performance of the design both subjectively, by listening to it, and objectively, by using a sensitive loudness measuring microphone. The Mic & Headphones circuit is shown in the figure below.

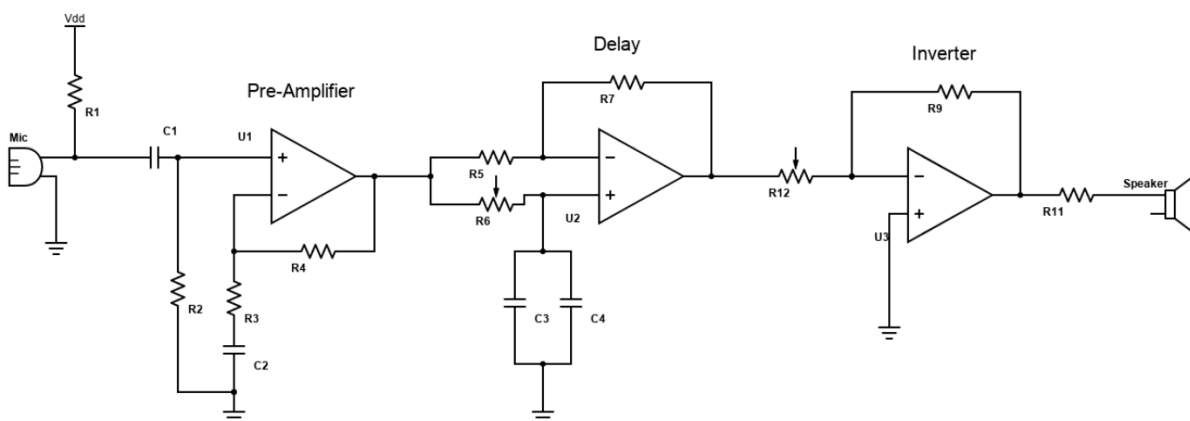

Figure 6 - The mic & headphones circuit design

There are several other modifications that were made to the circuit in this iteration. Firstly, the low-pass filter from the voltage supply was not needed as concluded when testing the amount of noise from the voltage supply provided by the breadboard. Next, a potentiometer R6 is used instead of a fixed value resistor. This change was necessary in order to be able to adjust the amount of delay of this op-amp. The elements used in this circuit are shown in the table below.

Table 2 - Resistance and capacitance values of the circuit elements

Element	Resistors, k $\Omega$										Capacitors, $\mu$ F			
	R <sub>1</sub>	R <sub>2</sub>	R <sub>3</sub>	R <sub>4</sub>	R <sub>5</sub>	R <sub>6</sub> (pot)	R <sub>7</sub>	R <sub>9</sub>	R <sub>11</sub>	R <sub>12</sub> (pot)	C <sub>1</sub>	C <sub>2</sub>	C <sub>3</sub>	C <sub>4</sub>
Value	5	1000	1	15	10	20	10	10	0.1	1000	0.01	10	0.001	0.001

These values provide the pre-amplifier gain of 16, as well as a variable amount of delay, and a variable magnitude for the final output of the circuit.

### Headphones Only Circuit

The final circuit iteration was designed with the idea of testing the overall performance of the delay, inversion and the headphones output without the microphone input. These tests were completed both subjectively, by listening to it in the headphones, and objectively, by using a sensitive loudness measuring microphone. The Headphones Only circuit is shown in the figure below.

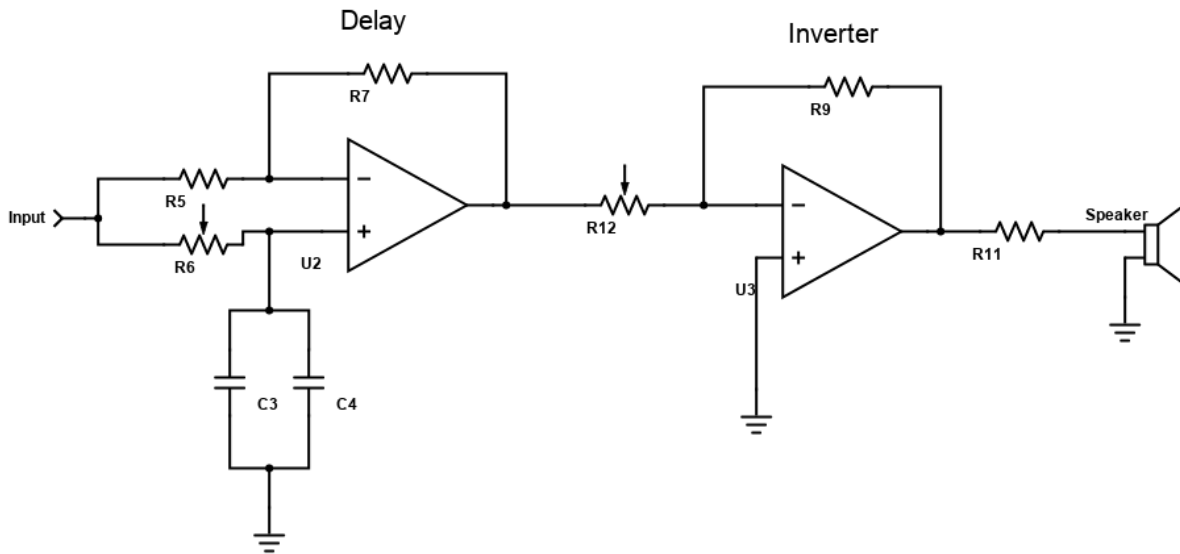

Figure 7 - The headphones only circuit design

This iteration of the circuit is driven by a waveform generator. This circuit also does not include the pre-amplifier, as its performance was found to bring unwanted noise amplification and delay for this circuit set up as shown further in the results section. The values of the components of the delay and inverter blocks are preserved to be the same as the Mic & Headphones circuit. These circuit design decisions were made due to the testing results outlined later in this report.

## **Testing methods**

Every circuit iteration introduced above was tested individually in its own manner. Below are the descriptions of the tests performed.

### **Reference circuit testing**

The tests on the reference circuit were run to determine the performance of different parts of the circuit as well as of the whole circuit. A waveform generator was used as the input to the circuit and the analysis was done using an oscilloscope. On top of that, a summing op-amp block was added. The inputs of the summing op-amp were the output of the noise canceling circuit, and the original input to the noise canceling circuit.

### **Mic & Headphones circuit Testing**

The second set of testing was performed on the Mic & Headphones circuit. The goal of these tests was to determine the best values of delay and output magnitude that would provide the best canceling of the sound playing from the speaker. Another goal of these tests was to measure the amount of noise-canceling done by the Mic & Headphones circuit. In this test, a speaker was set up on the side playing a sine wave at fixed frequencies. The microphone was fixed to the left earcup of the headphones and the output was delivered only to the left earcup of the headphones. The tester was sitting in a chair with the left earcup directed at the speaker. The tester slowly varied the output gain and the delay until a point of best noise cancellation was found. These adjustments were made while the speaker was playing a 100 Hz sine wave. Additionally to the subjective testing, an artificial “ear” with a hole in the middle was made from molding clay, shown in the figure below.





Figure 8 - A molded “ear” used in testing

The headphones were fixed tightly to the clay and a sensitive Brüel & Kjær 2270 microphone was inserted into the hole. Brüel & Kjær 2270 has an “A-weighting” setting which models its frequency response after a human ear, since the human hearing is not as sensitive to the low-end frequencies, and is more sensitive to high-mid frequencies. The volume of the noise was measured with the circuit off and the circuit on for multiple frequencies in the range from 60 Hz to 1 kHz. The testing setup is shown in the figure below.

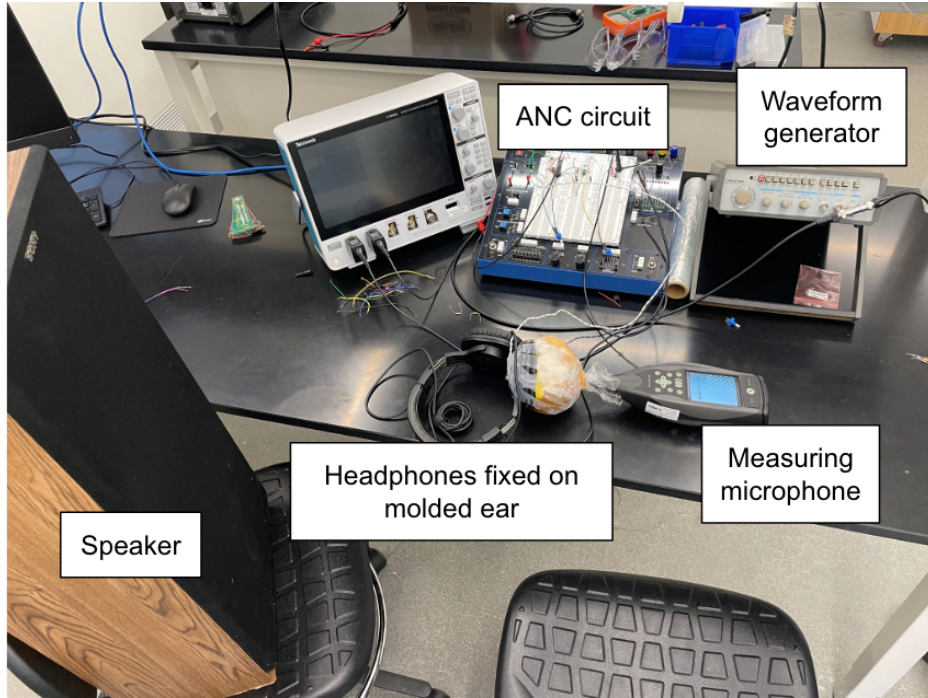

Figure 9 - The testing setup

### **Headphones Only circuit testing**

The third set of testing was performed on the Headphones Only circuit. The goal of these tests was to determine the performance of the circuit with a controlled input from a waveform generator instead of utilizing the microphone input and the pre-amplifier. The testing setup was the same as for the Mic & Headphones test. Both the speaker and the circuit were driven by a waveform generator from the same pin. The circuit output was driven into the headphones connected to the circuit. This set of testing was first performed subjectively, with a tester slowly varying the magnitude of the output and the amount of delay until the best sounding cancellation setting was reached. These adjustments were made with the waveform generator producing a 100 Hz sine wave. After that the same objective test was performed as with the Mic & Headphones

circuit, using the molded ear and the Brüel & Kjær 2270 microphone at multiple frequencies ranging from 60 Hz to 1 kHz.

## Results

### Reference Circuit results

The oscilloscope readings from the pre-amplifier block test are shown in the figure below.

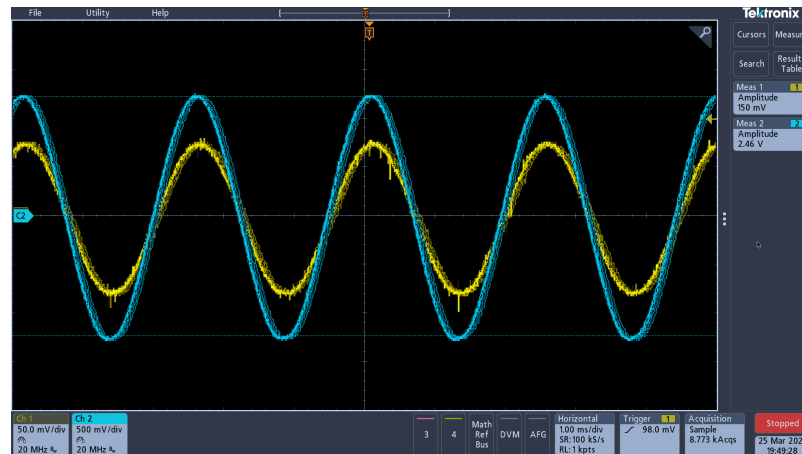

Figure 10 - Pre-amplifier analysis (output in blue)

As it can be seen from the figure above, the pre-amplifier works as expected. The input is in yellow and is at 150 mV of amplitude, whereas the output is in blue and is at 2.46 V of amplitude. This shows that the pre-amplifier block provides the gain of 16.4 (theoretical 16). However, it can also be seen that the pre-amplifier introduces a slight amount of delay to the output as the intersections of the input and the output waves do not lie exactly on the 0 V mark.

The oscilloscope readings from the pre-amplifier and delay blocks combined are shown in the figure below.

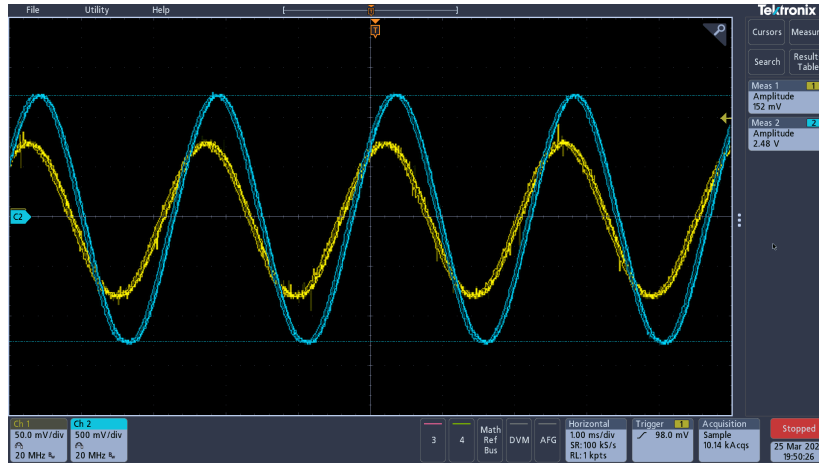

Figure 11 - Pre-amplifier and delay analysis (output in blue)

Figure 11 shows the output in blue with the amplitude of 2.48 V, and the input in yellow with the amplitude of 152 mV. This relationship shows that the gain provided to the signal is 16.3, which is consistent with the theory of the pre-amplifier providing the gain of 16 and the delay block having a unity gain. The delay of the output is apparent as it is shifted more than the output signal after just the pre-amplifier block shown in Figure 10.

The oscilloscope readings from the pre-amplifier and the inverter blocks combined are shown in the figure below.

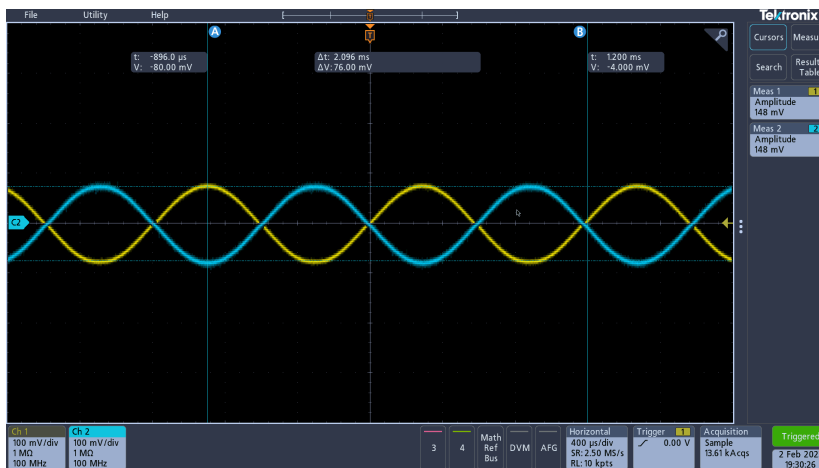

Figure 12 - Pre-amplifier and inverter analysis (output in blue)

The figure above shows the perfect inversion of the input wave. Moreover, the amplitudes of the input and the output are both at 148 mV, which shows that the gain of the inverter block compensates for the gain of the pre-amplifier, bringing the signal back to its original amplitude.

The oscilloscope readings from the summing amplifier, the inputs to which are the original input to the circuit and the output of the whole circuit are shown in the figure below.

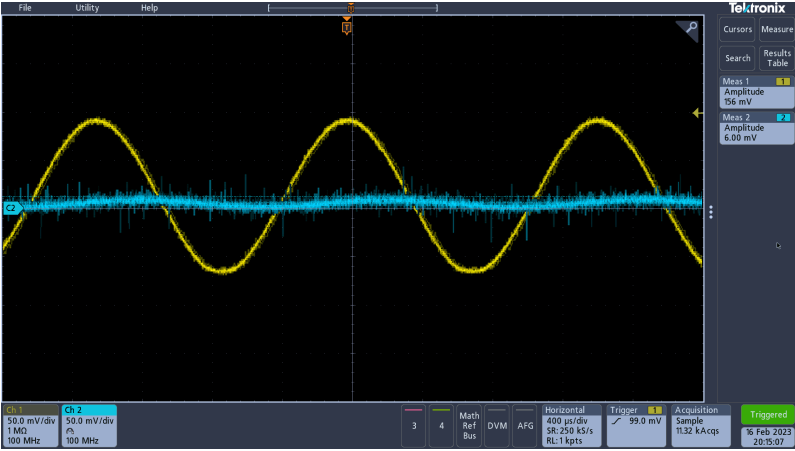

Figure 13 - Full circuit output summed with input in blue, input in yellow

From the figure above, it can be seen that the output of the circuit cancels the input out. The amplitude of the sum of the input and the output is at 6mV, which is 4% of the amplitude of the input.

**Mic & Headphones Circuit results**

The graph of the frequency response of the Mic & Headphones Circuit is shown below. The loudness of the background noise was measured at 38 dB, which was subtracted from all the further measurements in the tests which used the Brüel & Kjær 2270 microphone.

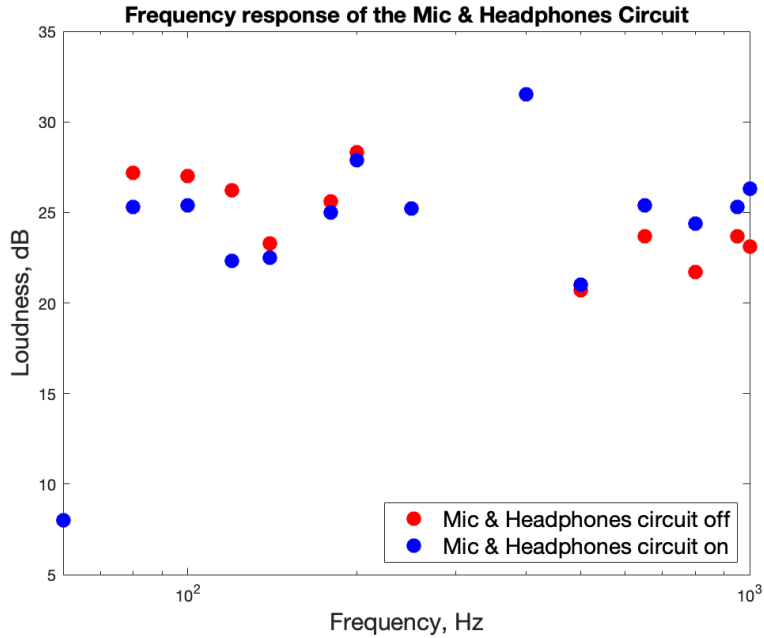

Figure 14 - Frequency response of the Mic & Headphones circuit

The graph shows some noise cancellation of about 1-4 dB happening in the range of 80-200 Hz.

At higher frequencies, there is little to no cancellation happening or the loudness when the circuit is on is higher when the circuit is off. This is due to the delay block being set for 100 Hz and not for the higher frequencies, where a different amount of delay is required.

### Headphones Only Circuit results

The graph of the frequency response of the Headphones Only Circuit is shown below.

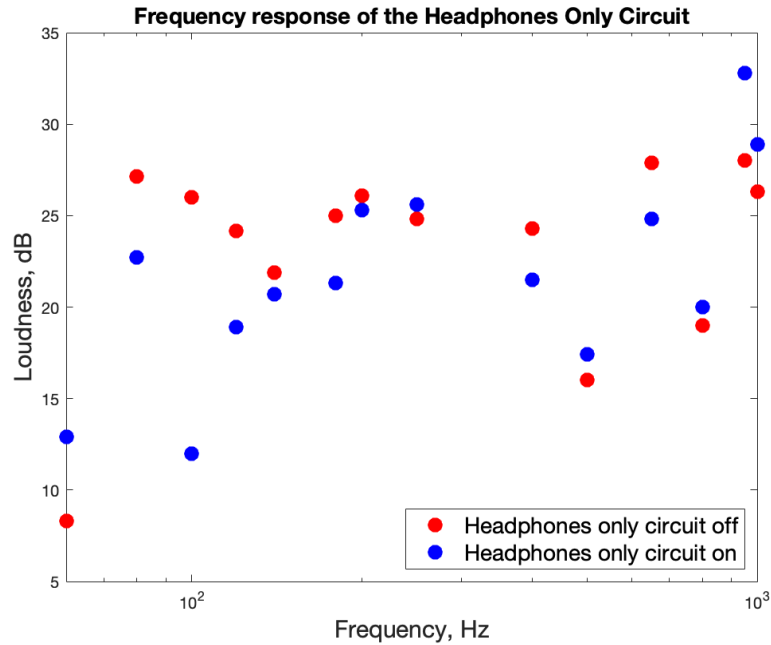

Figure 15 - Frequency response of the Headphones Only circuit

With this circuit setup, it can be seen from the graph that there is more than 5 dB of noise cancellation happening in the 80-120 Hz range, with the highest being 14 dB of cancellation at 100 Hz. There is also 1-3 dB noise canceling happening at higher frequencies until 800 Hz, with outliers at 250 and 500 Hz. The effect of the inappropriate setting for the delay block is more prevalent in this circuit as with the circuit on, the loudness is 3-5 dB higher than with the circuit off for 800 Hz to 1 kHz range. It can also be seen that with the circuit on, the loudness is higher at 60 Hz. This phenomenon can be explained by the fact that there is no need for the same amount of circuit output magnitude when it comes to a frequency that low compared to 100 Hz as our ear is not as sensitive for a frequency as low as 60 Hz. The headphones material also provides some passive noise cancellation, which is shown by the fact that with the circuit off, the loudness at 60 Hz is below 10 dB.



## Discussion

The reference circuit designs provided a good experimental knowledge about the op-amp blocks used in this circuit design. The pre-amplifier test shows that that block introduces some delay for the input signal at 400 Hz. It was also observed that the amount of delay introduced by the pre-amplifier depended on the frequency of the input signal. This phenomenon might be one of the reasons behind the Mic & Headphones not working as well as expected. If a variable amount of delay is introduced by the pre-amplifier block, it is very hard to determine a needed amount of delay delivered by the delay op-amp block for the output signal to be exactly 180 degrees out of phase with the ambient noise wave.

When testing the Mic & Headphones circuit, it was observed that even with a large value of the source voltage and the pull-up resistor, the pick up electret microphone's output signal was still at a very low voltage with some amount of electrical noise present. Another problem encountered with the electret microphone was that it was not picking up the ambient noise unless the source of that noise was located closer than ~10 inches to the microphone. This could also be a reason behind the Mic & Headphones circuit not behaving as well as expected. However, this insight suggests that a different microphone which picks up the ambient noise better and has less noise in its output may be needed. One such option would be a MEMS microphone, the inclusion of which in the circuit could be a potential extension to this project.

The tests of the Headphones Only circuit solidified the hypotheses of the microphone and the pre-amp blocks being a potential reason for the circuit's poor performance. Once those two elements were excluded when the Headphones Only circuit was tested, it was found that the circuit was behaving as expected and delivered at least 5 db of noise canceling in the lower end frequencies, with the highest being 14 db at 100 Hz. The importance of the  $R_{12}$  potentiometer

(output gain control) was shown during the subjective tests of the Mic & Headphones and the Headphones Only circuits. That potentiometer was useful in showing that using the same resistor value as used in the Reference circuit was invalid. That is due to the fact that when the headphones are worn on the head, there is a certain amount of passive noise cancellation happening due to the ambient noise having to travel through the material of the headphones. Based on that analysis, the output of the circuit should be of lower amplitude than the input. In a case when the output amplitude is too low, the user will hear the ambient noise. In a case when the output amplitude is too high, the user will be hearing the antinoise signal, which will sound like the ambient noise coming from the headphone speaker. However, when the output of the circuit is properly adjusted, it will cancel out the ambient noise and the user will hear the reduction in the volume of the noise. That effect was clearly heard when subjectively testing the Headphones Only circuit and slowly changing the gain of the circuit's output by changing the resistance value of the potentiometer.

The importance of the delay block was also shown in the Headphones Only testing. Even though the circuit provided a good amount of noise canceling in the lower-end frequencies, it can be seen from Figure 15 that there was an effect of noise amplification in the higher-end frequencies close to 1 kHz. That was happening due to the delay block being set up for the best performance at 100 Hz, which makes the delay of the final anti-noise signal output to be not exactly 180 out of phase with the original ambient noise at higher frequencies. This happens due to the fact that a small adjustment in delay does not have as much effect on the lower-end frequencies as it has on the higher-end, because the relative relationship between the amount of delay and the wavelength of the ambient noise signal is smaller for the lower frequencies than it is for the higher

frequencies. Thus, setting up the delay for 100 Hz could lead to the final delay being skewed from 180 degrees when testing with a signal close to 1 kHz.

One of the potential solutions to this problem would be to have a column of parallel bandpass filters followed by a column of parallel delay blocks. For each bandpass, there would be a different amount of delay introduced in its respective delay block. However, such a solution requires a lot more hardware and could end up taking up too much space in the final design, making it not feasible to be implemented on a PCB to fit on a pair of headphones.

Another possible solution would be for the circuit to use Digital Signal Processing instead of an analog delay block. Using a sophisticated algorithm, the frequency of the ambient noise can be determined and an accurate amount of delay can be applied to it in the Digital Signal Processing part of the circuit, which then can be fed to the inverter and then to the headphones. However, the initial idea of this project was to implement a fully analog circuit. Digital Signal Processing and sophisticated algorithms are used in commercial ANC headphones, the motivation for which is supported by this project's results of a fully analog circuit not being able to cover a wide range of frequencies when canceling the ambient noise.

## Constraints and Requirements

A design constraint outlined prior to the start of this project was regarding the size of the final PCB circuit: it had to fit on the earcups for the user to be able to carry the headphones around. However, due to the limitations of the circuit design, this project did not get to the stage of the PCB design and thus this constraint did not have any impact on this project.

The noise canceling requirement that was developed before the project was started was for the headphones to have at least 12 dB of noise cancellation for the ambient noise frequencies ranging between 500 Hz and 1 kHz. The final circuit design did not comply with this requirement, as there was only 3 dB of noise cancellation at 650 Hz, whereas at the other four frequencies measured in this range, there was noise amplification happening. However, throughout the project, a new requirement was developed for the 80-200 Hz frequencies to have at least 5 dB of noise cancellation. The circuit provided at least 5 dB of noise cancellation at 80 Hz, 100 Hz, 120 Hz, 180 Hz, with the highest being at 14 dB of cancellation at 100 Hz. The 140 Hz and 200 Hz frequencies did not see enough cancellation, or had slight amplification. Thus, this newly developed requirement was only partially fulfilled.

There were two more original requirements. First, for the headphones to do subjectively enough noise cancellation to study in one of Swarthmore College's libraries, and second for the autonomous working time of the circuit to be at least 2.5 hours. Again, due to the fact that the stage of implementing a PCB circuit and attaching it to the headphones was not reached, these requirements were never checked.

A standard for this circuit was to never output a signal at a volume higher than 85 dB, which was complied with due to the inclusion of a current limiting resistor at the end of the circuit before the input to the headphones.

## Conclusion

In this project, the performance of a fully analog Active Noise Cancellation circuit was evaluated. The Reference circuit produced an output that attenuated a 156 mV input to a 6 mV resulting wave, which is ~4% amplitude of the original input. The Reference circuit was simulating the ambient noise input using a waveform generator. The Mic & Headphones circuit did not perform as well as expected, providing 1-4 dB of attenuation in the 80-200 Hz range, little to no attenuation in the 200-650 Hz, and amplifying the ambient noise signal by 1-3 dB in the 650-1000 Hz range. The Headphones only circuit performed better by providing at least 5 dB of attenuation in the 80-650 Hz frequencies range, with several outlying frequencies and a maximum attenuation of 14 dB at 100 Hz. However, it also amplified the simulated ambient noise by 1-5 dB in the 800-1000 Hz frequencies range.

One of the possible future improvements to the circuit is replacing the electret microphone used in the circuit by a MEMS microphone. The importance of a good microphone was proven by the difference in the results of the Mic & Headphones circuit and the Headphones Only circuit, where the latter performed better according to the measured loudness at the chosen frequencies. Another possible improvement includes utilizing a Digital Signal Processing unit with an algorithm that sets a delay for the antinoise signal depending on its frequency. That improvement could potentially solve the problem of having an appropriate amount of delay for the lower-end frequencies, which at the same time is not an appropriate amount of delay for the higher end frequencies. This leads to the magnification of the ambient noise in the higher-end frequencies range.

## **Acknowledgements**

I would like to thank Professor Maggie Delano for supervising me on this project, Professor Carr Everbach for assisting me with the testing setup and the circuit design ideas, as well as Ed Jaoudi for providing me with certain elements necessary for the circuit design.

## References

- “Analog Noise Cancelling Headphones.” *Instructables*,  
[www.instructables.com/Analog-Noise-Cancelling-Headphones/](http://www.instructables.com/Analog-Noise-Cancelling-Headphones/).
- “ANC Headsets Aren’t All the Same: The Three Types of ANC · Jabra Blog.” *Jabra Blog*, 25  
Sept. 2015, [www.jabra.com/blog/anc-headsets-arent-all-the-same-three-types-of-anc/](http://www.jabra.com/blog/anc-headsets-arent-all-the-same-three-types-of-anc/).
- “Electret Microphone.” *Wikipedia*, 24 Feb. 2022, [en.wikipedia.org/wiki/Electret\\_microphone](https://en.wikipedia.org/wiki/Electret_microphone).
- Gether, Horst. “Active Noise Cancellation: Trends, Concepts, and Technical Challenges.” *EDN*,  
8 Oct. 2013,  
[www.edn.com/active-noise-cancellation-trends-concepts-and-technical-challenges/](http://www.edn.com/active-noise-cancellation-trends-concepts-and-technical-challenges/).
- “Interference of Sound.” *Gsu.edu*, 2019, [hyperphysics.phy-astr.gsu.edu/hbase/Sound/interf.html](http://hyperphysics.phy-astr.gsu.edu/hbase/Sound/interf.html).
- “PHYS 420C - Sound and Acoustics.” *Phys420.Phas.ubc.ca*,  
[phys420.phas.ubc.ca/p420\\_16/bartok1/sound\\_project.html](http://phys420.phas.ubc.ca/p420_16/bartok1/sound_project.html).
- Safe Listening Devices and Systems a WHO-ITU Standard*. 2019.
- “Types of Active Noise Cancellation Technologies.” *SoundsightR*, 5 Apr. 2022,  
[soundsightheadphones.com/noise-cancelling/types-of-active-noise-cancellation-technologies/](http://soundsightheadphones.com/noise-cancelling/types-of-active-noise-cancellation-technologies/).

## Appendix

A) The MATLAB code used to plot the frequency response graphs for the Mic & Headphones and the Headphones Only circuits.

```
freq = [60 80 100 120 140 180 200 250 400 500 650 800 950 1000];
circoff = [46.3 65.15 64 62.15 59.9 63 64.1 62.8 62.3 54 65.9 57 66
64.3];
circon = [50.9 60.7 50 56.9 58.7 59.3 63.3 63.6 59.5 55.4 62.8 58 70.8
66.9];
micoff = [46 65.2 65 64.2 61.3 63.6 66.3 63.2 69.5 58.7 61.7 59.7 61.7
61.1];
micon = [46 63.3 63.4 60.3 60.5 63.0 65.9 63.2 69.5 59 63.4 62.4 63.3
64.3];
circoff = circoff - 38;
circon = circon - 38;
micoff = micoff - 38;
micon = micon - 38;
semilogx(freq, micoff, 'Marker', 'o', 'LineStyle', 'none', 'MarkerSize',
9, 'MarkerEdgeColor', 'red', 'MarkerFaceColor', 'red');
hold on
semilogx(freq, micon, 'Marker', 'o', 'LineStyle', 'none', 'MarkerSize',
9, 'MarkerEdgeColor', 'blue', 'MarkerFaceColor', 'blue');
legend('Mic & Headphones circuit off', 'Mic & Headphones circuit on',
'location', 'se', 'FontSize', 14);
title('Frequency response of the Mic & Headphones Circuit', 'FontSize',
14);
ylabel('Loudness, dB', 'FontSize', 15);
xlabel('Frequency, Hz', 'FontSize', 15);
hold off
semilogx(freq, circoff, 'Marker', 'o', 'LineStyle', 'none',
'MarkerSize', 9, 'MarkerEdgeColor', 'red', 'MarkerFaceColor', 'red');
```



```
hold on

semilogx(freq, circon, 'Marker', 'o', 'LineStyle', 'none', 'MarkerSize',
9, 'MarkerEdgeColor', 'blue', 'MarkerFaceColor', 'blue');

legend('Headphones Only circuit off', 'Headphones Only circuit on',
'location', 'se', 'FontSize', 14);

title('Frequency response of the Headphones Only Circuit','FontSize',
14);

ylabel('Loudness, dB', 'FontSize', 15);

xlabel('Frequency, Hz', 'FontSize', 15);

hold off
```