



## UvA-DARE (Digital Academic Repository)

### The ECB and the rule of law

Smits, R.

**DOI**

[10.2866/14011](https://doi.org/10.2866/14011)

**Publication date**

2019

**Document Version**

Final published version

**Published in**

Building bridges: central banking law in an interconnected world

[Link to publication](#)

**Citation for published version (APA):**

Smits, R. (2019). The ECB and the rule of law. In *Building bridges: central banking law in an interconnected world: ECB Legal Conference 2019* (pp. 350-383). European Central Bank. <https://doi.org/10.2866/14011>

**General rights**

It is not permitted to download or to forward/distribute the text or part of it without the consent of the author(s) and/or copyright holder(s), other than for strictly personal, individual use, unless the work is under an open content license (like Creative Commons).

**Disclaimer/Complaints regulations**

If you believe that digital publication of certain material infringes any of your rights or (privacy) interests, please let the Library know, stating your reasons. In case of a legitimate complaint, the Library will make the material inaccessible and/or remove it from the website. Please Ask the Library: <https://uba.uva.nl/en/contact>, or a letter to: Library of the University of Amsterdam, Secretariat, Singel 425, 1012 WP Amsterdam, The Netherlands. You will be contacted as soon as possible.



EUROPEAN CENTRAL BANK

EUROSYSTEM

# Building bridges: central banking law in an interconnected world

ECB Legal Conference 2019

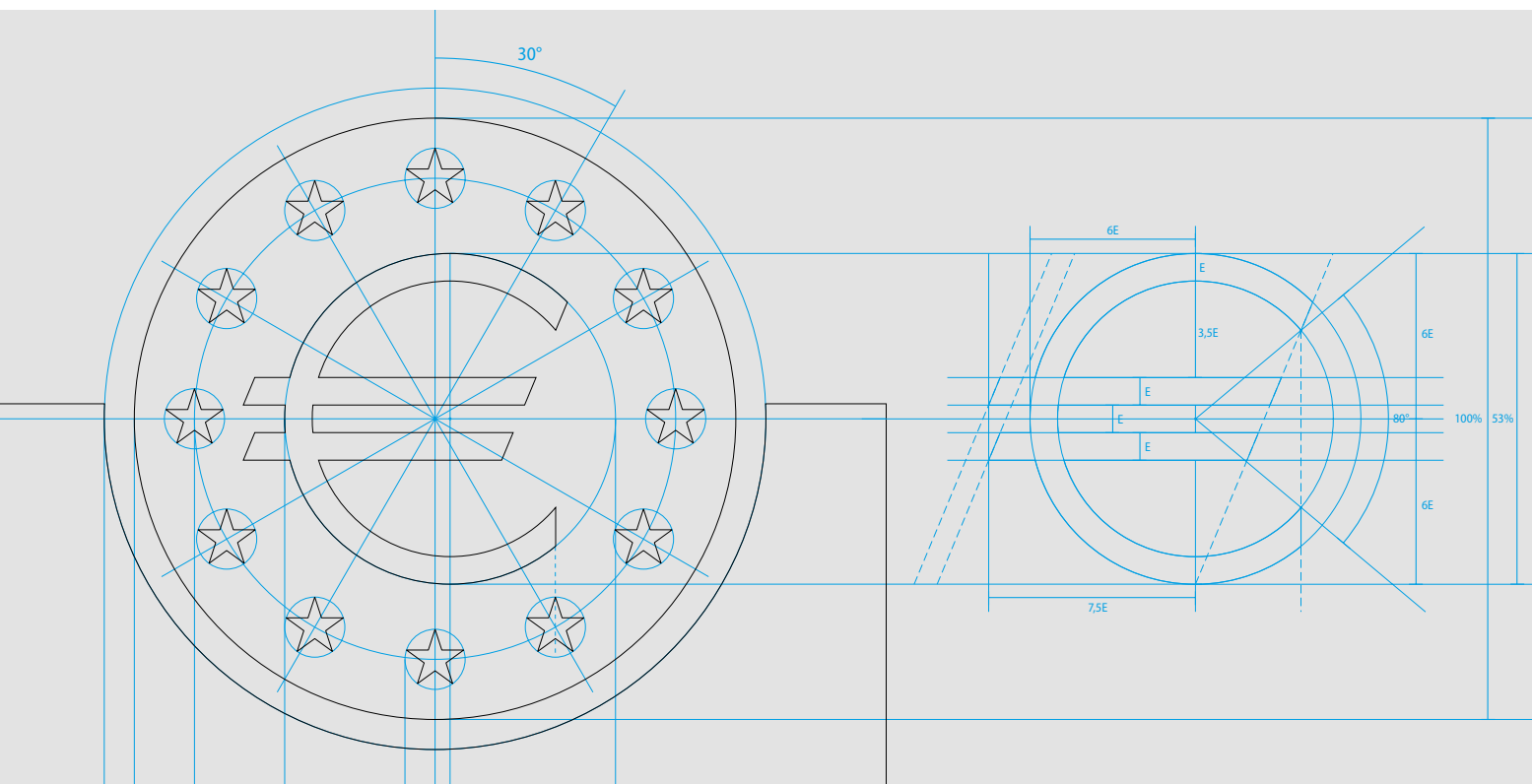

# The ECB and the rule of law

René Smits<sup>1</sup>

## 1 Introduction

It is a pleasure to contribute to this part of the book marking the first five years of functioning of the Administrative Board of Review (ABoR). In this contribution, I would like to start with a brief look back at the history of the rule of law in this place. The focus of my contribution is on the role of the rule of law<sup>2</sup> in a democratic order, a topical issue in these times<sup>3</sup> and on the part that administrative review of supervisory decisions of the European Central Bank (ECB) may play in upholding due process. I will discuss the acknowledgement by the Court of Justice of the European Union (CJEU) of the value of ABoR opinions in assessing the reasoning of subsequent ECB decisions. As an element of the rule of law, transparency is also crucial for the realisation of claims by applicants against decisions of supervisory authorities. In this context, I discuss access to supervisory files, where I introduce a proposal for reform that Nikolai Badenhoop and I have made, based on a trend we discern in recent court cases<sup>4</sup>. Concluding remarks will sum up my findings.

---

<sup>1</sup> Professor, Law of the Economic and Monetary Union, University of Amsterdam; Alternate, Administrative Board of Review; Assessor, Belgian Competition Authority; Consultant, RS Law & Society Consulting B.V. Several people have contributed to this paper: Lise Simon, Principal Secretariat Official at the ECB, by providing total figures for ECB legal acts; Federico Della Negra, Legal Counsel at the ECB, by commenting on an earlier version and verifying data on court proceedings; Grace Koshie, formerly Chief General Manager & Secretary to the Central Board of the Reserve Bank of India, by providing information on town hall meetings by the Indian central bank; and Jürgen Steinmetz, Visitors' Guide of Frankfurt's Jewish Museum who served as my guide to the Memorial on two occasions (in 2015 and in 2019). I note their contributions in gratitude but remain solely responsible for all opinions herein, and for any errors or omissions.

<sup>2</sup> Article 2 of the Treaty on European Union (TEU) provides: "The Union is founded on the values of respect for human dignity, freedom, democracy, equality, the rule of law and respect for human rights, including the rights of persons belonging to minorities. These values are common to the Member States in a society in which pluralism, non-discrimination, tolerance, justice, solidarity and equality between women and men prevail."

See the speech by Commission President-designate Ursula von der Leyen before the European Parliament on 16 July 2019 when, under the caption: "Defending Europe's values", she said: "The cradle of our European civilisation is Greek philosophy and Roman Law. And our European continent went through its darkest period when we were ruled by dictators and Rule of Law was banished. For centuries, Europeans fought so hard for their liberty and independence. The Rule of Law is our best tool to defend these freedoms and to protect the most vulnerable in our Union. This is why there can be no compromise when it comes to respecting the Rule of Law. There never will be. I will ensure that we use our full and comprehensive toolbox at European level. In addition, I fully support an EU-wide Rule of Law Mechanism. To be clear: the new instrument is not an alternative to the existing instruments, but an additional one. The Commission will always be an independent guardian of the Treaties. Lady Justice is blind – she will defend the Rule of Law wherever it is attacked." It is interesting to note that this quote does not contain any reference to religious sources of the European civilisation (notably, Judaism, Christianity and Islam, as institutionalised expressions of spirituality).

<sup>3</sup> See recent case law of the CJEU mentioned in footnote 21.

<sup>4</sup> René Smits, Nikolai Badenhoop, "Towards a single standard of professional secrecy for supervisory authorities – A reform proposal", *European Law Review* (44) 2019, pp.295-318.

## 2 History and the rule of law in a democratic order

### 1941-1945

This building has seen the most horrible violations of the rule of law.<sup>5</sup> I do not refer to the ECB but to what happened in the building that became (part of) the ECB's headquarters some 75 years later. Not all of you may be aware of the fact that the *Grossmarkthalle*, the architectural sensation of the 1920s which has been incorporated in the ECB's Main Building, contains a space that the Gestapo, the Nazi German police, had rented for rounding up Jewish citizens of Frankfurt before their deportation to the death camps. From 1941, citizens of this city who happened to be Jewish were assembled in an underground cellar-like room (around 1,100 people with just standing space), undergoing degrading treatment, including handing over a list of their possessions to be confiscated, a body search, *Entbürgerung* (removal of their German nationality) and paying a fee for the train ticket to their deaths. After long hours of waiting they were moved into trains to the extermination camps and, on one occasion of a 'spontaneous' round-up of citizens, to a Baltic beach to be shot dead as the camps were too crowded to receive them. A memorial (*Erinnerungsstätte*) in this building keeps alive the memory of these horrors<sup>6</sup>.

### Awareness for visitors and staff

I mention these uncomfortable facts here for two reasons. First, I consider that the ECB, one of the crowning results of European integration which began as a process to ensure that this was "never again"<sup>7</sup> to happen, should give ample attention to this part of the history of its headquarters. I plead for a clear plaque in the visitors' centre on the ground floor describing this part of the history of the ECB's headquarters with an open acknowledgment of the events of the dark years. A stark reminder of the atrocities committed against European minorities only eight decades ago helps to bring to mind, to both staff and visitors, the *raison d'être* for integration among the peoples of Europe<sup>8</sup>.

<sup>5</sup> I quote from ECB President Mario Draghi's words on the inauguration of this building: "We are standing here today in what used to be Frankfurt's former wholesale fruit and vegetable market, a state-of-the-art functional building from the 1920s that has largely been preserved and incorporated into the new structure. Between 1941 and 1945, more than 10,000 Jewish people from Frankfurt and nearby were deported from here to the concentration camps. A memorial on the east-side of the building has been built to remind us, and those who come after us, of deeds that cannot and must never be forgotten. An integrated, democratic and peaceful Europe was one of the key lessons from this dark chapter in history. We have come a long way since then – but nothing we have achieved should be taken for granted." Speech by Mario Draghi, President of the ECB, at the inauguration of the New ECB Premises, Frankfurt am Main, 18 March 2015, available at: <https://www.ecb.europa.eu/press/key/date/2015/html/sp150318.en.html>.

<sup>6</sup> See *The ECB Jewish Memorial and the European project*, speech by Vítor Constâncio, Vice-President of the ECB, on occasion of the inauguration of the Jewish Memorial at the ECB Main Building Großmarkthalle, Frankfurt am Main, 22 November 2015, available at: <https://www.ecb.europa.eu/press/key/date/2015/html/ecb.sp151122.en.html>.

<sup>7</sup> "(...) we want to ensure the "*Nie wieder*" (Never again) that is at the core of our hopes", quote from the speech by Vítor Constâncio, *ibid*.

<sup>8</sup> See: <https://www.ecb.europa.eu/ecb/premises/intro/memorial/html/index.en.html>.

Second, these events are a painful reminder of the importance of the rule of law in the proceedings of European institutions. Even though rule of law breaches possibly effected by the ECB may be minor in comparison to these horrors, a scrupulous adherence to due process, equality before the law and other fundamental rights is needed<sup>9</sup> to guard against slippage from the norms of our European society, and against a slide into dark territory which was only all too easily made by small steps<sup>10</sup>.

## Initiative to strengthen the rule of law in the EU: the ECB's contribution

In this context, it is worth reflecting on the contribution by the ECB<sup>11</sup> to the stakeholder consultation on the rule of law initiated by the European Commission<sup>12</sup> in the spring of this year<sup>13</sup> which, in July 2019, led to its adoption of an action plan<sup>14</sup>. The ECB begins by stating that “the rule of law escapes a comprehensive definition” and takes a perspective on the rule of law which emphasises enforcement of the law<sup>15</sup>, rather than protection on the basis of the law against public authorities’ transgressions. Understandably, the ECB then focuses on “domestic rule-of-law deficiencies” as these “may affect the ESCB and the ECB through their impact on national central banks”. I cite another part of the ECB’s contribution: “Populist, anti-establishment, and anti-expertise approaches that challenge independent institutions, focusing on their lack of direct connection with the “will of the people”, often fuel general mistrust against such institutions and target them sweepingly. This generalized challenge to independent authorities may also extend to national central banks”.

Noting the specific framework in which the ESCB operates in a “composite constitutional order”, namely with a Union institution and national central banks

<sup>9</sup> Again, citing Vítor Constâncio in his speech on 22 November 2015 (footnote 6): “The ECB, as one of the true pan-European supranational institutions is attached to the core values of the European project.”

<sup>10</sup> On the descent by small steps into ‘illiberal democracy’ in Hungary, a far cry from the horrors of Nazi Germany but a clear deviation from a free and democratic society nevertheless, see: The entanglement of powers – How the government of Viktor Orban hollowed out Hungary’s democracy, in *The Economist*, 31 August 2019, pp. 17-20. See the European Parliament resolution of 12 September 2018 on a proposal calling on the Council to determine, pursuant to Article 7(1) of the Treaty on European Union, the existence of a clear risk of a serious breach by Hungary of the values on which the Union is founded, available at: [http://www.europarl.europa.eu/doceo/document/TA-8-2018-0340\\_EN.html](http://www.europarl.europa.eu/doceo/document/TA-8-2018-0340_EN.html).

<sup>11</sup> *Commission’s Communication on further strengthening the Rule of Law – a central bank perspective*, the ECB’s contribution to the rule-of-law stakeholders discussion, available at: <https://www.ecb.europa.eu/pub/pub/legal/html/index.en.html>, p. 1.

<sup>12</sup> To which the current Finnish Presidency of the Council added support; see: *Common values and the rule of law: cornerstones of EU action*, available at: <https://eu2019.fi/en/priorities/values-and-the-rule-of-law>.

<sup>13</sup> See: [https://ec.europa.eu/info/policies/justice-and-fundamental-rights/upholding-rule-law/rule-law/initiative-strengthen-rule-law-eu\\_en#stakeholder-contributions](https://ec.europa.eu/info/policies/justice-and-fundamental-rights/upholding-rule-law/rule-law/initiative-strengthen-rule-law-eu_en#stakeholder-contributions).

<sup>14</sup> Communication from the Commission to the European Parliament, the European Council, the Council, the European Economic and Social Committee and the Committee of the Regions Strengthening the rule of law within the Union: A blueprint for action, COM/2019/343 final, at: <https://eur-lex.europa.eu/legal-content/EN/TXT/PDF/?uri=CELEX:52019DC0343&from=EN>.

<sup>15</sup> “At any rate, the rule of law requires that public authorities act in accordance with constitutional norms, including fundamental rights, and general rules that have been laid down by democratically elected organs, as well as that they actively ensure that the law is observed by private actors” (emphasis added).

mandated to operate as a coherent whole, the ECB emphasises the need for observance by national authorities of the pursuit of the public good of price stability<sup>16</sup>. Since “domestic rule-of-law deficiencies may affect the ESCB and the ECB through their impact on national central banks”, the specific measures which the Treaty and the Statute provide may assist in pursuing this objective effectively. The ECB mentions as part of the toolbox to guarantee the independent pursuit of price stability the annulment of a national measure relieving an NCB Governor from his functions<sup>17</sup>, elaborates on the specific infringement proceedings that the ECB may initiate against a deviant NCB<sup>18</sup> and includes the instruments of ECB opinions<sup>19</sup> and Convergence Reports<sup>20</sup>.

## Support and critique

While all this is certainly valuable in the context of the rule of law, the emphasis is on enforcement of public law of a constitutional nature which seems to overlook the issue of protection against the exercise of public functions. Such protection is also afforded by an independent judiciary, which is an indispensable element of the rule of law, as set out in recent case law<sup>21</sup>. From my perspective, two vital elements in upholding the rule of law in the area of central banking are absent from the reflections in the ECB’s ‘rule of law’ contribution: the protection against the ECB itself through administrative and judicial review of ECB acts and an open attitude of accountability. A word on each.

**Administrative and judicial review** may assist in ensuring that the ECB acts in observance of the highest standards of public conduct. I would like to cite a legal act recently adopted by the ECB itself, in the area of systemic payments systems

---

<sup>16</sup> I would have liked to see mentioned, additionally, financial stability.

<sup>17</sup> Judgment of 26 February 2019 in Joined Cases C-202/18 and C-238/18 *Ilmārs Rimšēvičs and ECB v Republic of Latvia* EU:C:2019:139 and Opinion of AG Kokott of 19 December 2018 in the same case, EU:C:2018:1030. See my blogpost of 5 March 2019: *ECJ annuls a national measure against an independent central banker*, available at: [https://europeanlawblog.eu/tag/case-c-%E2%80%991202-18-ilmars-rimsevics-v-republic-of-latvia/](https://europeanlawblog.eu/tag/case-c%E2%80%991202-18-ilmars-rimsevics-v-republic-of-latvia/).

<sup>18</sup> Article 271(d) of the TFEU and Article 35.6 of the Statute of the ESCB and of the ECB.

<sup>19</sup> For all opinions given by the ECB under its advisory powers on draft Union and national legislation (Article 127(4) of the TFEU and Article 4 of the ESCB Statute and, also Council Decision of 29 June 1998 on the consultation of the European Central Bank by national authorities regarding draft legislative provisions (98/415/EC) (OJ L 189, 3.7.98, p. 42). See, also: *The ECB’s advisory role – Overview of opinions (1994-2008)*, May 2009, available at: <https://publications.europa.eu/en/publication-detail/-/publication/1dfe9f3b-8f21-4a4d-8081-9ce562fc45a1>.

<sup>20</sup> For the Convergence Reports issued by the ECB on the basis of the provisions on accession to the Euro Area which is subject to qualification by the relevant Member State under the convergence criteria (Article 140(1) of the TFEU), available at: <https://www.ecb.europa.eu/pub/convergence/html/index.en.html>.

<sup>21</sup> Judgment of 27 February 2018 in Case C-64/16, *Associação Sindical dos Juizes Portugueses v Tribunal de Contas*, EU:C:2018:117; Judgment of 25 July 2018 in Case C-216/18 PPU, *Minister for Justice and Equality (Deficiencies in the system of justice)*, EU:C:2018:586; Order of 17 December 2018, EU:C:2018:1021, and Judgment of 24 June 2019 in Case C-619/18 R, *Commission v Poland*, EU:C:2019:531.

oversight – an area in which ECB has elaborated an entire system of oversight<sup>22</sup>, including a sanctions methodology<sup>23</sup> on the basis of Articles 22 and 34 of the ESCB Statute<sup>24</sup> – to give a definite description of what this would entail: “a competent authority should exercise [its powers] [...] in accordance with, and subject to, the general principles of proportionality, equal treatment, effectiveness, efficiency, transparency and procedural due process”<sup>25</sup>. Even if a positive definition of the rule of law escapes us, this enumeration of principles of good conduct for a public authority qualify its behaviour as in conformity with requirements of the rule of law. Independent outside review of its legal acts may foster this high level of conduct by the central bank.

As for **accountability**, the ECB’s contribution mentions “legitimate reflections on the scope and limits of central bank independence”, to be contrasted with undermining of independence by the forces of populism. I would like to see this scope for true debate expanded from reflections on the independence of central banks to substantive discussions of their role and their policies. After all, for “independent institutions [to act] as checks and balances to executive and legislative power”<sup>26</sup>, these independent institutions need themselves to be subject to checks and balances, including challenges from parliaments and courts. This requires flexibility in thinking by the central bank to achieve true responsiveness to the society it

<sup>22</sup> Judgment of 27 February 2018 in Case C-64/16, *Associação Sindical dos Juizes Portugueses v Tribunal de Contas*, EU:C:2018:117; Judgment of 25 July 2018 in Case C-216/18 PPU, *Minister for Justice and Equality (Deficiencies in the system of justice)*, EU:C:2018:586; Order of 17 December 2018, EU:C:2018:1021, and Judgment of 24 June 2019, in Case C-619/18 R, *Commission v Poland*, EU:C:2019:531. This payments systems oversight regime is set out in: Regulation of the European Central Bank (EU) No 795/2014 of 3 July 2014 on oversight requirements for systemically important payment systems (ECB/2014/28) (OJ L 217, 23.7.2014, p. 16), as amended by Regulation (EU) 2017/2094 of the European Central Bank of 3 November 2017 amending Regulation (EU) No 795/2014 on oversight requirements for systemically important payment systems (ECB/2017/32) (OJ L 299, 16.11.2017, p. 11); Decision (EU) 2017/2098 of the European Central Bank of 3 November 2017 on procedural aspects concerning the imposition of corrective measures for non-compliance with Regulation (EU) No 795/2014 (ECB/2017/33) (OJ L 299, 16.11.2017, p. 34); Decision (EU) 2017/2097 of the European Central Bank of 3 November 2017 on the methodology for calculating sanctions for infringements of the oversight requirements for systemically important payment systems (ECB/2017/35) (OJ L 299, 16.11.2017, p. 31); Decision (EU) 2019/1349 of the European Central Bank of 26 July 2019 on the procedure and conditions for exercise by a competent authority of certain powers in relation to oversight of systemically important payment systems (ECB/2019/25) (OJ L 214, 16.8.2019, p. 16). Also relevant is: European Central Bank Regulation (EC) No 2157/1999 of 23 September 1999 on the powers of the European Central Bank to impose sanctions (ECB/1999/4), OJ L 264/21, 12.10.1999, lastly amended by Regulation (EU) 2017/2095 of the European Central Bank of 3 November 2017 (OJ L 299, 16.11.2017, p. 22); consolidated text is available at: [https://www.ecb.europa.eu/ecb/legal/pdf/celex\\_01999r2157-20171206\\_en\\_txt.pdf](https://www.ecb.europa.eu/ecb/legal/pdf/celex_01999r2157-20171206_en_txt.pdf).

<sup>23</sup> Decision (EU) 2017/2097 of the European Central Bank of 3 November 2017 (ECB/2017/35) (OJ L 299, 16.11.2017, p. 31).

<sup>24</sup> The oversight of systemic payment systems is not affected by the issues surrounding the limits of the ECB’s competences in the area of settlements; see footnote 52 below.

<sup>25</sup> The quote is from recital 9 of the preamble to Decision (EU) 2019/1349. This ECB legal act specifies how competent authorities are to exercise powers in respect of systemically important payment systems (SIPS), based on a previous legal act of the ECB on how oversight of SIPS is to be conducted, in turn based on CPSS-IOSCO principles. For the CPSS-IOSCO – Principles for financial market infrastructures of April 2012, available at: <https://www.bis.org/cpmi/publ/d101a.pdf>. CPSS stands for Committee on Payment and Settlement Systems of the Bank for International Settlements (BIS) and IOSCO for the International Organization of Securities Commissions. The powers covered by this legal act published in the Official Journal on the 16th birthday of our eldest grandson Justin Smits, 16 August 2019, concern the right to obtain information, to require an independent expert report and to carry out on-site inspections with a SIPS (Article 21 of Regulation (EU) No 795/2014 (ECB/2014/28) as amended). Note that corrective measures and sanctions may also be imposed pursuant to Articles 22 and 23 of Regulation (EU) No 795/2014, as amended.

<sup>26</sup> As the ECB’s stakeholder contribution on the rule of law correctly describes independent central banks.

serves, and an open attitude towards unconventional approaches, something the ECB itself – rightly, so – demands of more conservative audiences in the euro area. There is a clear distinction between, on the one hand, populist anti-expert negativism and, on the other hand, alternative approaches and non-conformist reflections. Openness to the latter is what a central bank should adopt.

A case in point is the current debate on what banks and central banks should do to avoid a climate change<sup>27</sup> catastrophe<sup>28</sup>. The ideas about their role in this respect<sup>29</sup> have evolved quickly<sup>30</sup>. Also, the role of central banks<sup>31</sup> in fostering the achievement of the Sustainable Development Goals (SDGs)<sup>32</sup> has lately evolved. On climate change, a Network for Greening the Financial Sector (NGFS)<sup>33</sup> has been established, to which the ECB acceded. Even more generally, there is an ongoing discussion about the appropriate role for central banks in the area of human rights<sup>34</sup>. These are signs of the changing debate and of the speed with which mainstream thinking may shift.

The ECB may wish to adopt a more inclusive vision on the rule of law, including protection against the exercise of public authority by independent central banks, and encompassing accountability, responsiveness and transparency which, together, form the ART of central banking in a democracy<sup>35</sup>. I will come back to the

---

<sup>27</sup> The seminal contribution by Bank of England Governor Mark Carney needs to be mentioned: Mark Carney: *Breaking the tragedy of the horizon – climate change and financial stability*, speech by Mr Mark Carney, Governor of the Bank of England and Chairman of the Financial Stability Board, at Lloyd's of London, London, 29 September 2015, available at: <https://www.bis.org/review/r151009a.pdf>.

<sup>28</sup> For an inspiring view on sustainability issues facing the financial sector and its supervisors, see *Springtij* Opening address by Frank Elderson, Executive Director of De Nederlandsche Bank (DNB), Terschelling, 28 September 2018, available at: [https://www.dnb.nl/en/binaries/Springtij%20Opening%20address\\_tcm47-379653.pdf](https://www.dnb.nl/en/binaries/Springtij%20Opening%20address_tcm47-379653.pdf).

<sup>29</sup> See Dirk Schoenmaker, *Greening monetary policy*, Bruegel Working Paper No. 2, 19 February 2019, available at: <https://bruegel.org/2019/02/greening-monetary-policy/>; and Margherita Giuzio, Dejan Krusec, Anouk Levels, Ana Sofia Melo, Katri Mikkonen and Petya Radulova, *Climate change and financial stability*, *Financial Stability Review*, May 2019, available at: [https://www.ecb.europa.eu/pub/financial-stability/fsr/special/html/ecb.fsrart201905\\_1~47cf778cc1.en.html](https://www.ecb.europa.eu/pub/financial-stability/fsr/special/html/ecb.fsrart201905_1~47cf778cc1.en.html).

<sup>30</sup> See Sabine Lautenschläger: "In the area of banking supervision, this year the ECB has formally identified climate-related risk as one of the key risks facing the banking sector": Central Bankers, Supervisors and Climate-Related Risks, panel remarks by Sabine Lautenschläger, Member of the Executive Board of the ECB, at the Network for Greening the Financial System Conference, Paris, 17 April 2019, available at: <https://www.ecb.europa.eu/press/key/date/2019/html/ecb.sp190417~efcf14da2a.en.html>.

<sup>31</sup> See the speech by Frank Elderson at the *Sustainable Finance Seminar*, held at DNB on 27 November 2015: "With sustainability being at the heart of what we do, De Nederlandsche Bank sees a role for itself as a catalyst in the pursuit of sustainable development goals".

<sup>32</sup> The Sustainable Development Goals (SDGs) are a set of 17 global objectives for development for the year 2030, agreed by the United Nations General Assembly Resolution 70/1 (*Transforming our world: the 2030 Agenda for Sustainable Development*) on 25 September 2015, available at: [https://www.un.org/en/development/desa/population/migration/generalassembly/docs/globalcompact/A\\_RES\\_70\\_1\\_E.pdf](https://www.un.org/en/development/desa/population/migration/generalassembly/docs/globalcompact/A_RES_70_1_E.pdf).

<sup>33</sup> See: Network for Greening the Financial System *First comprehensive report - A call for action - Climate change as a source of financial risk*, April 2019, available at: [https://www.banque-france.fr/sites/default/files/media/2019/04/17/ngfs\\_first\\_comprehensive\\_report\\_-\\_17042019\\_0.pdf](https://www.banque-france.fr/sites/default/files/media/2019/04/17/ngfs_first_comprehensive_report_-_17042019_0.pdf).

<sup>34</sup> Daniel David Bradlow, *A Human Rights Based Approach to International Financial Regulatory Standards*, SouthViews, (171) October 2018, available at: <https://ssrn.com/abstract=3262463>.

<sup>35</sup> I have used the acronym ART to define democracy previously, in the wider context of EMU, where 'R' stands for 'representation', an element which is not apposite to use for an autonomous central bank. See: *From Subordinated to Prominent: The Role of the European Commission in EMU. Reflections on Euro Area Democracy*, in: Luigi Daniele, Pierluigi Simone and Roberto Cisolta (eds) *Democracy in the EMU in the Aftermath of the Crisis*, Springer, Cham, pp 51-71.



requirements of accountability, responsiveness and transparency throughout this contribution.

## 3 Independent review of ECB decisions

### 3.1 Introduction: reviewability of ECB measures

In a democratic society, decisions of public law authorities are subject to scrutiny by independent outsiders at the request of affected parties<sup>36</sup>. This scrutiny may take the form of independent administrative review, as in the case of the ABoR, and/or of independent judicial review. Beyond such review, acts by independent agencies are subject to democratic accountability before the legislative and executive functions of government, a subject which is beyond the purview of this contribution<sup>37</sup>. All forms of accountability require a level of transparency about the conduct of public authorities which allows the mechanisms of taking responsibility to work effectively.

Different kinds of decisions of the ECB may affect citizens in a variety of ways. Before focusing on the role of the ABoR, let me briefly explore three areas of activity where ECB measures affect citizens: (a) the ECB's original core mandate; (b) its troika role and (c) prudential supervision.

#### (i) Original core mandate

The mandate of the ECB includes, as the original and most visible part, core decisions on the course of the European economy: setting interest rates, engaging in standard and non-standard monetary policy operations and engaging in functions in respect of the euro's exchange rate, the official foreign reserves of the Member States of the euro area and the payment system. Such decisions are often generic in nature, are not addressed to individuals or do not affect a person directly or

<sup>36</sup> Assuming these parties have standing, an issue discussed below.

<sup>37</sup> See, with a focus on the ECB, the recent articles in the Maastricht Journal of European and Comparative Law, (26) 2019: Diane Fromage, "Guaranteeing the ECB's democratic accountability in the post-Banking Union era: An ever more difficult task?", pp. 48–62; Fabian Amtenbrink, "The European Central Bank's intricate independence versus accountability conundrum in the post-crisis governance framework", pp. 165–179; Anna-Lena Högenauer, David Howarth, "The democratic deficit and European Central Bank crisis monetary policies", pp. 81–93. See also: Pieter Van Cleynenbreugel, "Confidentiality behind transparent doors: The European Central Bank and the EU law principle of openness", Maastricht Journal of European and Comparative Law, (25) 2018, pp. 52–76; Ton Duijkersloot, Argyro Karagianni and Robert Kraaijeveld, "Political and judicial accountability in the EU shared system of banking supervision and enforcement", in *Law Enforcement by EU Authorities Implications for Political and Judicial Accountability*, Edited by Miroslava Scholten and Michiel Luchtman, 2017, pp. 28–52; Florin Coman-Kund, Anastasia Karatzia, Fabian Amtenbrink, "The Transparency of the European Central Bank in the Single Supervisory Mechanism", *Credit and Capital Markets – Kredit und Kapital*, (51) 2018, pp. 55–72; Deidre Curtin, "Accountable Independence" of the European Central Bank: Seeing the Logics of Transparency", *European Law Journal* (23) 2017, pp. 28–44; Nicolò Fraccaroli, Alessandro Giovannini and Jean-François Jamet, "The evolution of the ECB's accountability practices during the crisis", *ECB Economic Bulletin*, 2018, Issue 5, available at: [https://www.ecb.europa.eu/pub/economic-bulletin/articles/2018/html/ecb.ebart201805\\_01.en.html](https://www.ecb.europa.eu/pub/economic-bulletin/articles/2018/html/ecb.ebart201805_01.en.html); René Smits, "Accountability of the European Central Bank", *Ars Aequi*, January 2019, available at: <https://arsaequi.nl/product/accountability-of-the-european-central-bank/>.

individually, as the requirement for legality review requires (Article 263 of the Treaty on the Functioning of the European Union (TFEU))<sup>38</sup>. This implies that potential applicants have no standing against such decisions which do not 'directly and individually concern' them. Thus, decisions on monetary policy will not, normally be contested in court, at least not successfully: efforts to challenge decisions are likely to founder on 'standing'<sup>39</sup>.

An exception to this lack of justiciability of monetary policy decisions derives from challenges before national courts, notably of a constitutional nature, against ECB policies. These contestations may lead to proceedings that end up before the CJEU and lead it to decide on the legality of monetary policy measures. The *Gauweiler*<sup>40</sup> and *Weiss*<sup>41</sup> cases are well-known examples of such jurisprudence. Yet, in general, the ECB's monetary policy decisions<sup>42</sup> are unlikely to be challenged by individuals in court except, perhaps, in times of severe crisis as the proceedings mentioned above<sup>43</sup> make clear.

Allow me to add a remark about the effects of judicial scrutiny of monetary policy decisions. Such proceedings provide a forum for discussion of a technical issue which many have strong opinions about and, therefore, allow accountability since the protagonist of the policy needs to answer the judicial challenges of the opponents. This accountability aspect should not, however, become a clash about 'sovereignty'

---

<sup>38</sup> The terms 'individual concern' and 'direct concern' have been elaborated in case law. For 'direct concern', there has to be a direct effect in a person's legal position and no intermediation by any national measure in which the Member State administration has discretion. The term 'individual concern' has been explained, notably in the *Plaumann* judgment: "Persons other than those to whom a decision is addressed may only claim to be individually concerned if that decision affects them by reason of certain attributes which are peculiar to them or by reason of circumstances in which they are differentiated from all other persons and by virtue of these factors distinguishes them individually just as in the case of the person addressed." Judgment of 15 July 1963 in Case 25/62, *Plaumann & Co. v Commission of the European Economic Community*, EU:C:1963:17.

<sup>39</sup> Three proceedings initiated during the great financial crisis cum sovereign debt crisis deserve mentioning, the outcomes of which are available in other languages than English only:

- 1) In December 2011, the General Court turned down Mr. Städter's late challenge of ECB measures to widen the eligibility criteria of collateral to ensure continued use of Greek, Portuguese, and Irish government bonds in the monetary policy operations of the Eurosystem: Order of the General Court of 16 December 2011 in Case T-532/11, *Städter v ECB*, EU:T:2011:768; appeal rejected by Order of the Court of 15 November 2012 in Case C-102/12 P, EU:C:2012:723.
- 2) In December 2013, the General Court rejected the challenge instituted by applicant Mr. Von Storch and 5,216 other plaintiffs who opposed the ECB's announced Outright Monetary Transactions (OMT), holding that the OMT needed additional legal instruments and decisions subject to the discretion of the ECB to become operative, whereas the applicants were not directly concerned in the sense of the fourth paragraph of Article 263 TFEU: Order of the General Court of 10 December 2013 in Case T-492/12, *Sven A. von Storch and Others v ECB*, EU:T:2016:668.
- 3) In June 2014, the General Court rejected an action for the annulment of an ECB decision taken in the context of the downgrading of Greek government debt and the Private Sector Involvement (PSI), the write-down of privately held Greek government debt. This case was initiated by Mr. Alessandro Accortini and over 200 fellow plaintiffs from Italy who argued that, as holders of Greek government bonds, they were disadvantaged by an ECB decision that made the eligibility of Greek government bonds for Eurosystem operations conditional upon a credit enhancement: Order of the General Court of 25 June 2014 in Case T-224/12, *Alessandro Accortini and Others v ECB*, EU:T:2018:366.

<sup>40</sup> Judgment of 16 June 2015 in Case C-62/14, *Gauweiler*, EU:C:2015:400.

<sup>41</sup> Judgment of 11 December 2018 in Case C-493/17, *Weiss*, EU:C:2018:1000.

<sup>42</sup> Published by the ECB at: <https://www.ecb.europa.eu/mopo/decisions/html/index.en.html>.

<sup>43</sup> See footnote 39.

or precedence of norms: without the primacy of Union law over Member State law<sup>44</sup>, even of a constitutional nature, the Union cannot function, and monetary policy would be re-nationalised.

As indicated, the form that monetary policy decisions take also plays a role in this avoidance of judicial scrutiny: monetary policy decisions are not couched in an ‘administrative act’: a decision to set interest rates is an announcement to the market participants and the general public that the Eurosystem stands ready to engage in certain financial operations at a given price (interest rate). A decision to engage in certain financial transactions, again, is an announcement that particular operations will be undertaken. Such operations will be effected based on the General Documentation of the Eurosystem<sup>45</sup>, the provisions of the TFEU and the Statute of the ESCB and ECB, and, possibly, on the basis of specific legal acts adopted by the ECB<sup>46</sup>. Such legal acts are of a general nature and, again, will not directly and individually affect potential litigants. However, caution is required: the press release on Outright Monetary Transactions (OMT)<sup>47</sup> was assessed as to its legality under the ESCB’s mandate in the *Gauweiler* case, even though the CJEU also referred to the unpublished draft legal acts prepared by the ECB for the implementation of the OMT<sup>48</sup> which was never effected, the press release itself having done its work of assuaging market fears about a break-up of the currency union.

The ECB’s ‘core mandate’ encompasses more than monetary policy. Among the basic tasks entrusted to the ECB<sup>49</sup> are conducting foreign exchange operations consistent with the provision on the Union’s external position on monetary union and exchange rates (Article of the 219 TFEU)<sup>50</sup> and holding and managing the official foreign reserves of the Member States, including gold. Even though these tasks may involve the conclusion of agreements<sup>51</sup> and the adoption of positions which may be contested, they are unlikely to give rise to judicial review. The other ‘basic task’ of

---

<sup>44</sup> Established in the *Costa/ENEL* – judgment of 15 July 1964 in Case 6/64; EU:C:1964:66. See, also, Declaration No. 17 attached to the Final Act of Conference adopting the Treaty of Lisbon, which quotes the ruling: “the law stemming from the Treaty, an independent source of law, could not, because of its special and original nature, be overridden by domestic legal provisions, however framed, without being deprived of its character as Community law and without the legal basis of the Community itself being called into question”.

<sup>45</sup> Guideline (EU) 2015/510 of the European Central Bank of 19 December 2014 on the implementation of the Eurosystem monetary policy framework (General Documentation Guideline) (ECB/2014/60) (recast) (OJ L 91, 2.4.2015, p. 3) as most recently amended by Guideline (EU) 2019/1032 of the ECB of 10 May 2019 amending Guideline (EU) 2015/510 on the implementation of the Eurosystem monetary policy framework (ECB/2019/11) (OJ L 167, 24.6.2019, p. 64). See for a consolidated text before the latest amendment [https://www.ecb.europa.eu/ecb/legal/pdf/celex\\_02014o0060-20181001\\_en\\_txt.pdf](https://www.ecb.europa.eu/ecb/legal/pdf/celex_02014o0060-20181001_en_txt.pdf).

<sup>46</sup> See the overview of monetary policy instruments at: <https://www.ecb.europa.eu/ecb/legal/1002/1014/html/index-tabs.en.html>.

<sup>47</sup> Press release of 6 September 2012: *Technical features of Outright Monetary Transactions*, available at: [https://www.ecb.europa.eu/press/pr/date/2012/html/pr120906\\_1.en.html](https://www.ecb.europa.eu/press/pr/date/2012/html/pr120906_1.en.html).

<sup>48</sup> See Judgment of 16 June 2015 in Case C-62/14, *Gauweiler*, EU:C:2015:400, paragraph 71 where the Court refers to “draft legal acts considered during the meeting of the Governing Council at which the press release was approved”.

<sup>49</sup> Article 127(2) of the TFEU and Article 3.1 of the ESCB Statute.

<sup>50</sup> Article of the 138 TFEU is also relevant in this respect.

<sup>51</sup> Notable examples are the Agreement on Net Financial Assets (ANFA), available at: [https://www.ecb.europa.eu/ecb/legal/pdf/en\\_anfa\\_agreement\\_19nov2014\\_f\\_sign.pdf](https://www.ecb.europa.eu/ecb/legal/pdf/en_anfa_agreement_19nov2014_f_sign.pdf); and the Central Bank Gold Agreement, to expire on 26 September 2019, available at: [https://www.ecb.europa.eu/press/pr/date/2019/html/ecb.pr190726\\_1~3eaf64db9d.en.html](https://www.ecb.europa.eu/press/pr/date/2019/html/ecb.pr190726_1~3eaf64db9d.en.html).

promotion of the smooth operation of payment systems has, as noted above, led to an oversight structure for systemically important payment systems which the ECB has elaborated on the basis on international standards and EU law<sup>52</sup>. Probably, this oversight function has not (yet?) given rise to challenges in court by supervised entities.

## (ii) The role of the ECB in crisis solution and surveillance

This is not the place to discuss extensively how the ECB's contribution to the solution of the financial and sovereign debt crisis has been reviewed by the courts. Numerous others have written on the issue of the judicial review of conditionality measures<sup>53</sup> which, naturally, have been the outcome of a multi-institutional input and cannot be solely attributed to the ECB. Yet, in the context of the rule of law, it is relevant to note how difficult it has been for affected parties who became applicants against elements of the conditionality they suffered from to hold the originators of these measures to account before the courts. Legally speaking, the ECB may not have been responsible for the measures which Member States' governments adopted in order to comply with the conditions for funding of their budgets or bailing out of their banks, as the Court found in the *Pringle* case<sup>54</sup>. Thus, judicial accountability of the ECB for conditionality measures could not have been achieved<sup>55</sup> even though the principle of liability for damages in case of violation of the Charter of Fundamental Rights of the European Union (Charter of Fundamental Rights) has been established<sup>56</sup>. Yet, in situations of distress where normal political discourse is unable to express popular preferences, ex-post recourse to the courts

---

<sup>52</sup> Notably, Article 22 of the ESCB Statute. On the scope of the ECB's regulatory powers under Article 22, focussing on the exclusion of clearing systems in securities, see paragraphs 86-110 of the judgment of 4 March 2015 in Case T-496/11, *United Kingdom v ECB*, EU:T:2015:133. On the subsequent legislative proposal to amend Article 22, see: <http://www.europarl.europa.eu/legislative-train/theme-deeper-and-fairer-internal-market-with-a-strengthened-industrial-base-financial-services/file-amendments-to-esbc-ecb-statute>.

<sup>53</sup> Notably: René Repassi, "Judicial protection against austerity measures in the euro area: Ledra and Mallis", *Common Market Law Review* (54) 2017, pp. 1123–1156; Michael Ioannidis, "EU Financial Assistance Conditionality after "Two Pack"", *ZaöRV* (74) 2014, pp. 61-104; Anastasia Poulou, "Financial assistance conditionality and human rights protection: what is the role of the EU Charter of Fundamental Rights?", *Common Market Law Review* (54) 2017, pp. 991–1026.

<sup>54</sup> Judgment of 12 November 2012 in Case C-370/12, *Pringle*, EU:C:2012:756, paragraph 161: "(...) the duties conferred on the Commission and ECB within the ESM Treaty, important as they are, do not entail any power to make decisions of their own. Further, the activities pursued by those two institutions within the ESM Treaty solely commit the ESM".

<sup>55</sup> Judgment of 20 September 2016 in Joined Cases C-105/15 P to C-109/15 P, *Konstantinos Mallis and Others v European Commission and European Central Bank*, EU:C:2016:702, notably paragraphs 57 and 58: "(...) the fact that the Commission and the ECB participate in the meetings of the Eurogroup does not alter the nature of the latter's statements and cannot result in the statement at issue being considered to be the expression of a decision-making power of those two EU institutions; [n]or is there anything in the statement at issue reflecting a decision of the Commission and the ECB to create a legal obligation on the Member State concerned to implement the measures which it contains". This judgment concerned the Eurogroup statement of 25 March 2013 concerning the restructuring of the banking sector in Cyprus.

<sup>56</sup> Judgment of 20 September 2016 in Joined Cases C 8/15 P to C 10/15 P, *Ledra Advertising v ECB*, EU:C:2016:701.

may make the citizens feel heard and acknowledged<sup>57</sup> even if unsuccessful in their original quest<sup>58</sup>. Broader access to the courts for affected individuals may contribute to the sense that the rule of law applies. Bringing the European Stability Mechanism (ESM) into the Union legal framework, as the European Commission has proposed<sup>59</sup> and the ECB endorsed<sup>60</sup>, would enhance the democratic accountability and the judicial reviewability of ESM measures to which the ECB has contributed.

### (iii) The role of the ECB in prudential supervision

Decisions in the area of prudential supervision, the latest shoot on the ECB's mandate tree, are the most suitable for outside review, and the ones where affected parties are likely to have standing.

Since the activation of Article 127(6) of the TFEU by the Council, when it adopted the SSM Regulation<sup>61</sup>, the ECB has adopted slightly more than 9,000 legal acts of a supervisory nature<sup>62</sup>. This number does not include the fee decisions which are annually adopted for each bank in the euro area, whether classified as significant or less significant, i.e. a total of 10,000 up until now. A tiny minority among these 9,000 or 19,000 acts has been contested, either in administrative or in judicial review. Thirty review cases came before ABoR, or around 0,0015% of all legal acts (excluding fee decisions: 0,003%)<sup>63</sup>.

Affected parties may be credit institutions to which decisions have been addressed on licensing, capital adequacy, liquidity, risk management or governance (including

---

<sup>57</sup> The following passage adequately sums up the popular feeling about representation after the great financial crisis (*Democracies need renewal if they are to survive*, Tony Barber, Financial Times, 20 August 2019): "During the 2008 financial crisis and its aftermath, a sense of extreme inequality and unfairness has gripped millions of citizens, coupled with the feeling that their political institutions offered too little scope for doing much about it. As governments bailed out banks, recouping the money by raising taxes and cutting the welfare state, citizens felt they were carrying the can for unaccountable elites who captured the state and business world. Slow-burning frustration was intensified by the feeling that politics is now the preserve of special interests."

<sup>58</sup> Judgment of 13 June 2017 in Case C-258/14, *Florescu*, EU:C:2017:448.

<sup>59</sup> Communication from the Commission to the European Parliament, the European Council, the Council and the European Central Bank: *Further Steps Towards Completing Europe's Economic And Monetary Union: A Roadmap*; COM(2017) 821 final, 6.12.2017, available at: <https://eur-lex.europa.eu/legal-content/EN/TXT/PDF/?uri=CELEX:52017DC0821&from=EN>; and Proposal for a Council Regulation on the establishment of the European Monetary Fund; COM(2017) 827 final, 6.12.2017, available at: [https://eur-lex.europa.eu/resource.html?uri=cellar:050797ec-db5b-11e7-a506-01aa75ed71a1.0002.02/DOC\\_1&format=PDF](https://eur-lex.europa.eu/resource.html?uri=cellar:050797ec-db5b-11e7-a506-01aa75ed71a1.0002.02/DOC_1&format=PDF). For the history and development of this legislative proposal, see: <http://www.europarl.europa.eu/legislative-train/theme-deeper-and-fairer-economic-and-monetary-union/file-integration-of-the-esm-into-eu-law-by-creating-an-emf>.

<sup>60</sup> Opinion of the European Central Bank of 11 April 2018 on a proposal for a regulation on the establishment of the European Monetary Fund (CON/2018/20), OJ C 220, 25.6.2018, p. 2.

<sup>61</sup> Council Regulation (EU) No 1024/2013 of 15 October 2013 conferring specific tasks on the European Central Bank concerning policies relating to the prudential supervision of credit institutions (OJ L 287, 29.10.2013, p. 63).

<sup>62</sup> Based on the numbers of supervisory decisions published in the ECB's Annual reports on banking supervision: 2104: 120; 2015: ~1,500; 2016: 1,835; 2017: 2,308; and 2018: 1,924. For the first eight months of 2019, 75% of the number for last year has been taken (1,443) to arrive at this sum total.

<sup>63</sup> For the percentage of court cases against the number of ECB legal acts, see below.

as a result of the annual SREP exercise<sup>64</sup>) or decisions on the (dis-)qualification of shareholders with a qualifying holding, or putative bank managers and non-executive directors who disagree with the ECB's assessment of applications<sup>65</sup> for their positions. Moreover, there may have been informal 'nods and winks' which may affect parties (proposed members of the management body, shareholders who have purchased a stake beyond the threshold for assessment of qualifying holdings<sup>66</sup>, or others), without necessarily granting them standing given the informal nature of such measures. The numbers given above should be assessed in the context of the potentially far greater figure of measures when one includes such 'informal acts'.

The judicial and administrative review hurdle for standing is threefold: if the decision is not addressed to the applicant itself, he or she must be directly and individually concerned and have an interest in the proceedings<sup>67</sup>. This latter requirement may be quite a hurdle in case of a decision which is not addressed to the applicant. The CJEU has consistently reiterated that the interest in bringing proceedings is an essential and fundamental prerequisite for any legal proceeding<sup>68</sup> and it cannot concern a future and hypothetical situation<sup>69</sup>. This interest must be vested and current<sup>70</sup>. Even though the ABoR is not an adjudicating body, the ABoR has considered 'interest' to be a prerequisite for its own administrative review.

## 3.2 Administrative review

By far the easiest route to a reconsideration of an ECB supervisory decision, or the imposition of the annual fee, is to access the ABoR: a swift procedure, usually involving a hearing of the parties (the applicant and the ECB), resulting in an opinion

---

<sup>64</sup> SREP stands for Supervisory Review and Evaluation Process; see Articles 97- 104 CRD IV (Directive 2013/36/EU of the European Parliament and of the Council of 26 June 2013 on access to the activity of credit institutions and the prudential supervision of credit institutions and investment firms, amending Directive 2002/87/EC and repealing Directives 2006/48/EC and 2006/49/EC, OJ L 176, 27.6.2013, p. 338, amended by Directive (EU) 2019/878 of the European Parliament and of the Council of 20 May 2019 amending Directive 2013/36/EU as regards exempted entities, financial holding companies, mixed financial holding companies, remuneration, supervisory measures and powers and capital conservation measures, OJ L 150, 7.6.2019, p. 253).

<sup>65</sup> Applications which may have emanated from the credit institution instead of themselves, which opens the question of their standing when challenging an ECB decision. The numbers given here exclude the supervisory fee decisions which, as addressed to supervised banks and imposing a contribution, may also give rise to review requests.

<sup>66</sup> Article 22 of CRD IV. Note that such thresholds may be lower under relevant national law which the ECB is to apply pursuant to Article 4(3) of the SSM Regulation.

<sup>67</sup> See paragraph 63 of the judgment of 17 September 2009 in Case C-519/07 P, *Commission v. Koninklijke FrieslandCampina NV*, EU:C:2009:556: "According to settled case-law, for an applicant to have an interest in bringing proceedings in the light of the subject-matter of the action, that action must be capable, through its outcome, of procuring an advantage to the party which brought it (see, to that effect, judgment of the Court of 25 July 2002 in Case C-50/00 P, *Unión de Pequeños Agricultores v Council*, EU:C:2002:462, paragraph 23; judgment of 3 April 2003 in Case C-277/01 P, *Parliament v Samper*, EU:C:2003:196, paragraphs 30 and 31; Order of 5 March 2009 in Case C-183/08 P, *Commission v Provincia di Imperia*, paragraph 19 and the case-law cited).

<sup>68</sup> See, inter alia, paragraph 58 of the judgment of 17 September 2015 in Case C-33/14 P, *Mory SA, Mory Team, Superga Invest v European Commission*, EU:C:2015:609.

<sup>69</sup> See, inter alia, paragraphs 16 and 17 of the judgment of 20 June 2013 in Case C-269/12 P, *Guillermo Cañas v Commission*, EU:C:2013:415.

<sup>70</sup> See, inter alia, paragraph 34 of the judgment of 26 February 2015 in Case C-564/13 P, *Planet AE Anonymi Etaireia Parochis Symvouleftikon Ypiresion v European Commission*, EU:C:2015:124.

to the Supervisory Board on the contested act, within the limits of the grounds for review. This leads the Supervisory Board to submit a new draft decision to the Governing Council. Such a decision may be abrogating the original decision, replacing it with a decision of identical content or adopting a different decision<sup>71</sup>.

The ABoR is to provide independent, “internal administrative review”, establishing whether, in its opinion, the decision is procedurally and substantively in conformity with the SSM Regulation, “while respecting the margin of discretion left to the ECB to decide on the opportunity to take those decisions”<sup>72</sup>. Since the SSM Regulation itself is part of Union law, and instructs the ECB to base its decisions on binding Union law<sup>73</sup>, the ABoR has taken this instruction to mean that it can assess whether a contested act is in conformity with the SSM Regulation, the Treaty<sup>74</sup>, the Charter of Fundamental Rights and any fundamental principles underlying the Treaties<sup>75</sup>. Among the references in the SSM Regulation to the rule of law, recital 58 stands out: “In its action, the ECB should comply with the principles of due process and transparency”<sup>76</sup>. Significantly, the SSM Regulation, in recital 63, instructs the ECB to uphold the rights and freedoms enshrined in the Charter of Fundamental Rights<sup>77</sup>. The Council, when adopting the SSM Regulation, stated, in recital 86, that this basic regulation “respects the fundamental rights and observes the principles recognised in the Charter of Fundamental Rights of the European Union, in particular the right to the protection of personal data, the freedom to conduct a business, the right to an effective remedy and to a fair trial, and has to be implemented in accordance with those rights and principles”.

The ABoR opinion, being part of the ongoing decision-making process at the ECB, is itself not contestable before the General Court but the resulting second ECB decision adopted after administrative review is. This second decision cannot be put

---

<sup>71</sup> Article 24(7) of the SSM Regulation. See, also, Article 16(2) and Article 17(1) of Decision of the European Central Bank of 14 April 2014 concerning the establishment of an Administrative Board of Review and its Operating Rules (ECB/2014/16) (2014/360/EU) (OJ L 175, 14.6.2014, p. 47), as amended by Decision (EU) 2019/1378 of the European Central Bank of 9 August 2019 amending Decision ECB/2014/16 concerning the establishment of an Administrative Board of Review and its Operating Rules (ECB/2019/27) (OJ L 224, 28.8.2019, p. 9) (hereafter: ABoR Decision).

<sup>72</sup> Recital 64 to the SSM Regulation.

<sup>73</sup> Recital 32 to the SSM Regulation: “The ECB should carry out its tasks subject to and in compliance with relevant Union law including the whole of primary and secondary Union law, Commission decisions in the area of State aid, competition rules and merger control and the single rulebook applying to all Member States”; and recital 34: “(...) the ECB should, when adopting guidelines or recommendations or when taking decisions, base itself on, and act in accordance with, the relevant binding Union law”.

<sup>74</sup> See recital 54 to the SSM Regulation: “(...) the ECB is an institution of the Union as a whole. It should be bound in its decision-making procedures by Union rules and general principles on due process and transparency. The right of the addressees of the ECB’s decisions to be heard should be fully respected as well as their right to request a review of the decisions of the ECB according to the rules set out in this Regulation”.

<sup>75</sup> See also recital 48 to the SSM Regulation on “[l]egal profession privilege [as] a fundamental principle of Union law”.

<sup>76</sup> See also, recital 61 to the SSM Regulation: “In accordance with Article 340 TFEU, the ECB should, in accordance with the general principles common to the laws of the Member States, make good any damage caused by it or by its servants in the performance of their duties”.

<sup>77</sup> Recital 63 to the SSM Regulation reads as follows: “When determining whether the right of access to the file by persons concerned should be limited, the ECB should respect the fundamental rights and observe the principles recognised in the Charter of Fundamental Rights of the European Union, in particular the right to an effective remedy and to a fair trial”.

before ABoR again<sup>78</sup>. An applicant who is dissatisfied with the outcome should go to the General Court.

The ABoR opinion is not public. Even the fact that the opinion has been adopted is not known beyond the affected parties: the applicant and the ECB<sup>79</sup>. It is only through any subsequent judicial proceedings that the opinion may become known. In several cases, the General Court has referred to, and even cited, the ABoR opinion in its reasoning in a follow-up case.

The lack of transparency for third parties about the existence and outcome of administrative review proceedings is an element that the ABoR proceedings share with many national administrative review proceedings but which is regrettable from a transparency perspective nevertheless<sup>80</sup>. The ABoR proceedings are confidential unless the Governing Council authorises the ECB President to make the outcome of the ABoR proceedings public<sup>81</sup>. There is a case to be made for more frequent and more explicit information on the ABoR proceedings and for including in the President's monthly press conference a sentence on administrative review outcomes. More regular information may consist of a quarterly website item on the number of review requests and opinions and the subject matter of the review proceedings.

A sentence on the ABoR review in monthly media information might contain a reference to the actual outcome: a proposal to abrogate the original decision, to replace it with a decision of identical content or to replace it with an amended one which, one assumes, will be better reasoned<sup>82</sup>. One might envision the following information:

- (i) Number of review requests;
- (ii) Number of ABoR opinions adopted;
- (iii) Nature of the ABoR opinions:
  - I. Declaring the review request inadmissible;
  - II. Proposing the abrogation of the contested ECB decision;
  - III. Proposing the confirmation of the contested decision (to be "replaced with a decision of identical content" in the wording of Article 16(2) of the ABoR Decision);

---

<sup>78</sup> Article 24(5), second sentence, of the SSM Regulation in conjunction with Article 24(7).

<sup>79</sup> Article 18 of the ABoR Decision (Notification).

<sup>80</sup> Note that decisions by the Board of Appeals of the European Supervisory Authorities are in the public domain; see: <https://www.esma.europa.eu/about-esma/governance/board-appeal> and <https://eba.europa.eu/about-us/organisation/joint-board-of-appeal/decisions>.

<sup>81</sup> Article 22 of the ABoR Decision (Confidentiality and professional secrecy).

<sup>82</sup> The three options the ABoR opinion is to set forth pursuant to Article 16 of the ABoR Decision (Opinion on the review). See the similar language in the third sentence of Article 24(7) of the SSM Regulation.



- IV. Proposing the replacement of the contested decision with an amended one, including when the ABoR suggested improving the reasoning, as is declared publicly in the ECB's Annual Reports on supervisory activities;
- (iv) Whether suspension of the contested decision has been sought, and granted (or not);
- (v) Nature of the contested issue (e.g., significance, SREP, fit and proper assessment, corporate governance, withdrawal of a license, assessment of the suitability of a shareholder, etc.);
- (vi) General issue(s) relevant in the review (e.g., the need for harmonisation of national supervisory law, or a banking culture issue such as the importance of good internal governance of credit institutions, as were specified in the ECB's 2015 Annual Report)<sup>83</sup>;
- (vii) Whether proceedings have been undertaken before the General Court.

For reasons of professional secrecy, the following information must remain internal:

- (viii) Names of the applicants, or of their legal representatives;
- (ix) Nationality of the applicants;
- (x) Member State of origin of the case.

On the transparency and impact of the work of the ABoR, two reflections are in order.

One should note that, even when the ABoR concludes that the original decision is correct in terms of outcome (by respecting the ECB's margin of discretion, as it should)<sup>84</sup>, the ABoR is also likely to suggest to the ECB to improve the reasoning (motivation) of the legal act.

Also noteworthy is that administrative review proceedings have an effect beyond the case at hand. When during a hearing, and in contacts with the ECB aimed to obtain background to a case at hand, the ABoR asks specific questions or brings up certain issues, this will lead to reflection on the part of the ECB and may lead to changes in the way supervision is effected in future cases.

---

<sup>83</sup> *ECB Annual Report on supervisory activities*, March 2016, p. 15, available at: <https://www.bankingsupervision.europa.eu/ecb/pub/pdf/ssmar2015.en.pdf>.

<sup>84</sup> Recital 64 to the SSM Regulation.

There are three main reasons why, up until now, the ABoR's work has been undertaken almost completely 'in the dark': making known the outcome of the review may prejudice potential follow-up proceedings (either the applicant or the ECB will be known to have 'lost' in the administrative review phase) and, more importantly, information on the outcome without full disclosure of the opinion only provides limited insight. Moreover, the appeal judgment in the *L-Bank* case (more on this will be said below) clarifies that an opinion of the ABoR is to be attributed to the ECB<sup>85</sup>. Since the ECB's supervisory decisions generally are not public, this argues against dissemination of the ABoR opinions. It is therefore to the Court's judgments that one should look for more insight on the ABoR's reasoning concerning the ECB's original motivation and for information on the occurrence of administrative review.

### 3.3 Judicial review

The option of going to Luxembourg is always open, instead of, or after, administrative review<sup>86</sup>. Later on, I will discuss the interplay between administrative and judicial review. First, the focus is on the number of relevant banking union-related cases against the ECB before the CJEU<sup>87</sup>.

Based on publicly available information, Federico Della Negra and I regularly identify these cases and provide brief insights into them on our list of proceedings at the website of the European Banking Institute (EBI)<sup>88</sup> which distinguishes between the following classes of actions:

- (a) Actions for annulment against ECB supervisory decisions
- (b) Actions for failure to act against the ECB
- (c) Actions against decisions of the Single Resolution Board (SRB)
  - 3.1. Actions for annulment of SRB Decisions on contributions to the Single Resolution Fund (SRF)
  - 3.2. Actions related to the resolution of *Banco Popular Español S.A.*
  - 3.3. Actions related to *ABLV Bank, AS* and *ABLV Bank Luxembourg, SA*

---

<sup>85</sup> "[The ABoR] opinion, [the ECB's ] new draft decision and [its final] decision originate from the same institution, namely the ECB": paragraph 92 of the judgment of 8 May 2019 in Case C-450/17 P, *Landeskreditbank Baden-Württemberg – Förderbank v ECB*, EU:C:2019:372.

<sup>86</sup> Article 24(11) of the SSM Regulation and Article 19 of the ABoR Decision (Recourse to the Court of Justice).

<sup>87</sup> Focused as this paper is on the SSM, instances of judicial review concerning resolution are not covered here.

<sup>88</sup> This overview *The Banking Union and Union Courts: overview of cases*, is available at: <https://ebi-europa.eu/publications/eu-cases-or-jurisprudence/>.

(d) Other proceedings on Union banking law (CRR<sup>89</sup>, CRDIV<sup>90</sup>, SSM Regulation, BRRD<sup>91</sup>, FICOD<sup>92</sup>, DGS Directive<sup>93</sup>)

(e) Judicial proceedings concerning Banking Union legislation and/or acts of Union institutions before national courts

For completeness' sake, it should be noted that banking union-related cases against the ECB on our list may also involve its 'failing or likely to fail' assessments in relation to banks put under resolution. As this contribution focuses on the Single Supervisory Mechanism (SSM), these cases are not included in the current count.

We count 47 proceedings against the ECB<sup>94</sup>, which can be arranged as follows:

### State of proceedings:

- one case ultimately decided on appeal (*L-Bank*);
- seven cases<sup>95</sup> pending on appeal (*Arkéa* [2 cases]<sup>96</sup>; *Trasta* [3 cases]<sup>97</sup>; *De Masi and Varoufakis* on access to documents concerning the Eurosystem's (in

<sup>89</sup> Regulation (EU) No 575/2013 of the European Parliament and of the Council of 26 June 2013 on prudential requirements for credit institutions and investment firms and amending Regulation (EU) No 648/2012 (OJ L 176, 27.6.2013, p. 1) as amended by Regulation (EU) 2019/876 of the European Parliament and of the Council of 20 May 2019 amending Regulation (EU) No 575/2013 as regards the leverage ratio, the net stable funding ratio, requirements for own funds and eligible liabilities, counterparty credit risk, market risk, exposures to central counterparties, exposures to collective investment undertakings, large exposures, reporting and disclosure requirements, and Regulation (EU) No 648/2012 (OJ L 150, 7.6.2019, p. 1).

<sup>90</sup> See footnote 64.

<sup>91</sup> Directive 2014/59/EU of the European Parliament and of the Council of 15 May 2014 establishing a framework for the recovery and resolution of credit institutions and investment firms and amending Council Directive 82/891/EEC, and Directives 2001/24/EC, 2002/47/EC, 2004/25/EC, 2005/56/EC, 2007/36/EC, 2011/35/EU, 2012/30/EU and 2013/36/EU, and Regulations (EU) No 1093/2010 and (EU) No 648/2012, of the European Parliament and of the Council (OJ L 173, 12.6.2014, p. 190), as amended by Directive (EU) 2019/879 of the European Parliament and of the Council of 20 May 2019 amending Directive 2014/59/EU as regards the loss-absorbing and recapitalisation capacity of credit institutions and investment firms and Directive 98/26/EC (OJ L 150, 7.6.2019, p. 296).

<sup>92</sup> Directive 2002/87/EC of the European Parliament and of the Council of 16 December 2002 on the supplementary supervision of credit institutions, insurance undertakings and investment firms in a financial conglomerate and amending Council Directives 73/239/EEC, 79/267/EEC, 92/49/EEC, 92/96/EEC, 93/6/EEC and 93/22/EEC, and Directives 98/78/EC and 2000/12/EC of the European Parliament and of the Council (OJ L 35, 11.2.2003, p. 1).

<sup>93</sup> Directive 2014/49/EU of the European Parliament and of the Council of 16 April 2014 on deposit guarantee schemes (OJ L 173, 12.6.2014, p. 149).

<sup>94</sup> The list counts 44 cases (as does the table below). Since the two *Trasta* cases have led to three separate appeals on the preliminary issue of admissibility of shareholders (not on the substantive issue), when counting *proceedings* pending or concluded one comes to a total of 47. Again, there are more proceedings against the ECB in relation to resolution of banks, an issue outside the purview of this paper.

<sup>95</sup> After this paper was presented, judgments were pronounced in several of the pending cases; these are indicated in the footnotes below. The qualification of these cases as 'pending' was not altered.

<sup>96</sup> Judgments of 13 December 2017 in Case T-712/15, *Crédit Mutuel Arkéa v ECB*, EU:T:2017:900 and in Case T-52/16, *Crédit Mutuel Arkéa v ECB*, EU:T:2017:902; judgment of 2 October 2019, in Joined Cases C-152/18 P and C-153/18 P, *Crédit Mutuel Arkéa v ECB*, EU:C:2019:810.

<sup>97</sup> See Order of 12 September 2017 in Case T-247/16, *Trasta Komerbanka and Others v ECB* (renamed as *Fursin and Others v ECB*) EU:T:2017:623, rejecting the claim of Trasta Komerbanka as inadmissible and upholding the shareholders' claim as admissible; appeals by the ECB (C-663/17 P), the Commission (Case C-665/17 P) and by Trasta Komerbanka (Case C-669/17 P) were lodged. A judgment in the appeal cases was delivered on 5 November 2019; EU:C:2019:923.

my view: erroneous<sup>98</sup>) interpretation of Article 14.4 of the ESCB Statute on its lender-of-last-resort (LOLR) or Emergency Liquidity Assistance (ELA)<sup>99</sup> competences; one case on the alleged failure of the ECB to instruct the Banco de Portugal (*Comprojecto-Proyectos e Construções and Others v ECB*)<sup>100</sup>;

- twelve cases closed:
  - six cases by the French banks acting against the ECB's misuse of its discretion in the application of a CRR provision permitting a zero-weighting for certain assets (namely, *Livret A and Livret de Développement Durable et solidaire* (LDD) accounts) in the calculation of the leverage ratio;
  - four cases by *Crédit Agricole* on the separation of the exercise of executive and non-executive functions within a bank's management body;
  - one case on an ECB preparatory act (*Pilatus Bank v ECB*).
- 27 cases pending.

This classification shows how long it takes to get an end result on SSM-related issues.

The number of proceedings does not give a direct insight into the nature of supervisory issues fought over before the European courts as some issues give rise to multiple proceedings. Therefore, the following classification may be more insightful.

---

<sup>98</sup> See my *Competences and alignment in an emerging future - After L-Bank: how the Eurosystem and the Single Supervisory Mechanism may develop*, ADEMU WP 2017/077, available at: <http://ademu-project.eu/wp-content/uploads/2017/12/0077-Competences-and-alignment-in-an-emerging-future.pdf>, pp. 27-29.

<sup>99</sup> Judgment of 12 March 2019 in Case T-798/17, *De Masi and Varoufakis v ECB*, EU:T:2019:154 and Case C-342/19 P, *De Masi and Varoufakis v ECB*, pending.

<sup>100</sup> Order of 14 February 2019 in Case T-768/17, *Comprojecto-Proyectos e Construções and Others v ECB*, EU:T:2019:104 and Order of 2 October 2019 in Case C-251/19 P, *Comprojecto-Proyectos e Construções and Others*, EU:C:2019:813.

**Table 1**Overview of issues in SSM-related court proceedings against the ECB<sup>101</sup>

Issue	Number of cases	Applicant(s)				
Significance decisions	2	L-Bank	PNB Banka			
Withdrawal of licence (-related)	7	Trasta [3]	Niemelä	Ukrselhosprom [2]	Bernis	Pilatus [3]
Sanctions	4	Banco de Sabadell	Crédit agricole [3]			
Suitability of new shareholders (acquisition of qualifying holdings in credit institutions)	3	Fininvest and Berlusconi	ZZ	PNB Banka		
Governance (group; non-executive director)	5	Arkéa [2]	Crédit Agricole [4]			
Application of capital requirements	16	French banking industry Livret 1 [6]	French banking industry on irrevocable payment commitments (deposit guarantee schemes or resolution funds - 2017) [6]	French banking industry on irrevocable payment commitments (deposit guarantee schemes or resolution funds - 2018) [4]		
Access to documents	4	Aeris Invest [2]	OCU	De Masi and Varoufakis		
Issues ECB/ NCA	2	Comprojecto-Projectos e Construções [Portugal]	Triantafyllopoulos [Greece]			
On-site inspection	1	PNB Banka				
Total number of cases	44					

Again, the figures may not tell everything for several reasons. The access to documents cases mainly concern documents related to the resolution of *Banco Popular Español*. Although they are clearly 'cases against the ECB' and the ECB alone<sup>102</sup>, they could be excluded here as they are beyond the scope of attention in this contribution. One case on access to documents concerns LOLR assistance or, in Eurosystem parlance: ELA<sup>103</sup>. We consider this to be so closely linked to banking supervision that we include it on our list. Others may consider the issue to fall under monetary policy.

<sup>101</sup> Although the Curia website may shield the names of an applicant against a sanction, these can be derived from the information on the ECB's website on supervisory sanctions, see <https://www.bankingsupervision.europa.eu/banking/sanctions/html/index.en.html>.

<sup>102</sup> There are numerous proceedings against the Single Resolution Board currently pending, several among which include the ECB and or the Commission as defendants. See Smits/Della Negra, *The Banking Union and Union Courts: overview of cases as at 19 August 2019*, available at: <https://ebi.europa.eu/publications/eu-cases-or-jurisprudence/>.

<sup>103</sup> See: *Emergency liquidity assistance (ELA) and monetary policy*, available at: <https://www.ecb.europa.eu/mopo/ela/html/index.en.html>.

Also, multiple proceedings concerning the same course of events may blur the picture: the revocation of the authorisation of three banks led to various proceedings. Furthermore, the litigious French banks acting together on issues of capital requirements blow up the numbers.

Numbers are not conclusive, however: judgments should not only be counted but, also weighted: even a single judgment may have a noticeable effect on the way the ECB interprets its margin of supervisory discretion. Still, when looking at the figures for the court proceedings, a few patterns may be discerned.

**Concerted action by the main banks in a single jurisdiction** (France) stands out: sixteen cases were initiated by the French banking industry, concerning two issues, namely the treatment of certain publicly privileged assets in solvency requirements (including this exposure in the calculation of the leverage ratio) and regulatory treatment of commitments in respect of deposit insurance and resolution funds. The judgments in the first six cases mark a resounding victory for the French banks.

**Proceedings in the context of the revocation of a banking licence:** Seven such cases have been initiated.

**A certain specialisation in contesting ECB measures:** as one can expect, certain lawyers and law firms return in various cases to challenge the ECB.

**Less significant institutions (LSIs) challenging the ECB:** as the ECB issues and withdraws banking licences and is responsible for the authorisation of the acquisition of qualifying shareholdings for all euro area banks, it could be expected that proceedings emanate from smaller banks, as well. Their preponderance in challenging ECB legal acts is remarkable even though one needs to recognise that the ultimate contestants may not be 'less significant' parties.

**Apparent eagerness to challenge:** while the numbers are still relatively small, certainly when put into the perspective of the total number of supervisory acts<sup>104</sup>, the tendency to challenge the supervisor is remarkable. Taking a euro area-wide perspective, there is an impression of increased eagerness to confront the supervisor in court compared to the pre-SSM period even though the nationality of contestants varies<sup>105</sup> and, in some Member States, there may not have been any reluctance to challenge supervisory decisions prior to the advent of the SSM.

In the area of prudential supervision, references for a preliminary ruling on elements of the Single Rulebook or contestations of the constitutionality of banking union may provide further instances for judicial review, as the 31 July 2019 judgment of the German Constitutional Court on 'banking union'<sup>106</sup> makes clear. As regards the German Constitutional Court's 're-interpretation' of the CJEU's judgments in the *L-*

<sup>104</sup> Forty-four cases on 9,000 legal acts of a supervisory nature translate into a judicial challenge rate of 0.005% (0.0023% against 19,000 acts, i.e. including fee decisions).

<sup>105</sup> One may note the absence of any judicial challenges of SSM legal acts from the Benelux or Finland thus far.

<sup>106</sup> Judgment of 30 July 2019, 2 BvR 1685/14, 2 BvR 2631/14, available at: [https://www.bundesverfassungsgericht.de/SharedDocs/Entscheidungen/DE/2019/07/rs20190730\\_2bvr168514.html](https://www.bundesverfassungsgericht.de/SharedDocs/Entscheidungen/DE/2019/07/rs20190730_2bvr168514.html).

*Bank* case, the same remark applies as I made above on the primacy of Union law. See the Annex for this issue.

## 4 Due process: the ABoR's role

The intervention by the ABoR implies a new round of discussions, after the initial hearing that the parties usually get in the process leading up to a supervisory decision<sup>107</sup>. The arguments raised against the draft decision can be made again, this time before independent experts, who review the case file and, in many instances, organise a hearing, presided over by the ABoR Chair, allowing the applicant to confront the ECB. Naturally, the hearing also allows the ECB to reiterate its reasoning, or to improve upon it. The whole process is intended to enhance the decision-making by bringing up the issues of relevance for the decision and the procedural steps taken. The ABoR is not an inquisitive body, however, as its review is limited to an examination of the grounds relied upon in the notice of review<sup>108</sup>.

Our experience has been that the hearing provides a good opportunity to dig up the underlying issues dividing the applicant and the ECB and, possibly, to make the parties listen better to each other, under the guidance of independent reviewers. Another feature which has helped the ABoR understand the issues and conclude with an opinion on the case is the 'comments table', an annex attached to an ECB decision which summarises the earlier discussion of the ECB with the bank. This annex sets out the comments made by the bank during the right to be heard<sup>109</sup>, provides the ECB's assessment thereof and specifies the adjustments to the draft decision (if any) made by the ECB in response to those remarks. The ABoR considers this annex to be a part of the contested decision and may rely on it to assess whether the ECB's reasoning (motivation) for the contested decision has been adequate.

The responsiveness of the ECB to reasonable arguments by the applicant forms, in my view, part of the observance by the central bank of the requirements of the rule of law. It goes without saying that such responsiveness implies openness to reasonable arguments based on a different, more business-centred point of view on the issues. Such responsiveness does not at all imply foregoing the ECB's statutory, indeed constitutional task of supervising banks with a view to their safety and soundness. Thus, firm maintenance of strict prudential standards may never be at variance with the rule of law; inflexible adherence to a demonstrably incorrect perspective on a situation might need to be corrected in administrative or judicial proceedings to ensure the application of the rule of law.

---

<sup>107</sup> Article 31 of Regulation (EU) No 468/2014 of the European Central Bank of 16 April 2014 establishing the framework for cooperation within the Single Supervisory Mechanism between the European Central Bank and national competent authorities and with national designated authorities (SSM Framework Regulation) (ECB/2014/17), (OJ L 141, 14.5.2014, p.1).

<sup>108</sup> Article 10(2) of the ABoR Decision. Note that, afterwards, the Supervisory Board is not bound by the review grounds submitted by the applicant before the ABoR when proposing a new draft decision to the Governing Council: Article 17(1) of the ABoR Decision.

<sup>109</sup> Article 31 of the SSM Framework Regulation.

## 5 The Court and the ABoR

This brings us to follow-on proceedings in Luxembourg: judicial review of decisions taken after an ABoR opinion. A number of cases proceed to the CJEU after an administrative review, while quite a few other court proceedings are initiated directly without an ABoR review procedure. As already indicated, it is difficult to achieve transparency on which court cases were launched after an ABoR review, given that the ABoR opinions are not in the public domain and their existence only becomes known if made known by the court. A previous ABoR review may become known early on, in case the applicant before the court has mentioned the ABoR opinion in the grounds for its request for annulment of the ECB's decision, or later, when the court issues its judgment and may refer to the ABoR opinion. In rare cases, a keen observer may deduce from a repeated request for annulment of an ECB decision by the same applicant that an administrative review has preceded the second request: the two-month interval between the two court proceedings on the same kind of decision must imply that a second decision on the same subject matter has been issued<sup>110</sup>.

In the few cases on which we know from public sources that ABoR proceedings have led to follow-on proceedings in Luxembourg, there have been a couple of noteworthy instances where the General Court welcomed the ABoR's reasoning and even made it its own.

Most noteworthy, in the *L-Bank* case, the first case coming to Luxembourg on banking union, the General Court referred to the ABoR opinion on several instances, and found that "the Administrative Board of Review's Opinion is part of the context of which the contested decision forms a part and may, therefore, be taken into account for the purpose of determining whether that decision contained a sufficient statement of reasons"<sup>111</sup>. The General Court held that "in so far as the contested decision ruled in conformity with the proposal set out in the Administrative Board of Review's Opinion, it is an extension of that opinion and the explanations contained therein may be taken into account for the purpose of determining whether the contested decision contains a sufficient statement of reasons"<sup>112</sup>.

The General Court assessed the adequacy of the reasoning in the ECB's second decision also based on the ABoR opinion, noting that it relied on "a combined reading of the contested decision and the Administrative Board of Review's Opinion"<sup>113</sup>. This was confirmed on appeal where the CJEU held in paragraphs 92 to 96 of its judgment<sup>114</sup> that:

---

<sup>110</sup> See Articles 16 and 17 of the ABoR Decision for the two-month period for an ABoR opinion and the 30 working days period for the adoption of the second decision by the Governing Council of the ECB.

<sup>111</sup> Judgment of 16 May 2017 in Case T-122/15, *Landeskreditbank Baden-Württemberg – Förderbank v ECB*, EU:T:2017:337, paragraph 125.

<sup>112</sup> Judgment of 16 May 2017 in Case T-122/15, *Landeskreditbank Baden-Württemberg – Förderbank v ECB*, EU:T:2017:337, paragraph 127.

<sup>113</sup> Judgment of 16 May 2017 in Case T-122/15, *Landeskreditbank Baden-Württemberg – Förderbank v ECB*, EU:T:2017:337, paragraph 128.

<sup>114</sup> Judgment of 8 May 2019 in Case C-450/17 P, *Landeskreditbank Baden-Württemberg – Förderbank v ECB*, EU:C:2019:372.



“92 It therefore follows from the provisions of Article 24 of [the SSM Regulation] and from [the ABoR Decision] that that opinion, that new draft decision and [the second] decision [by the Governing Council] originate from the same institution, namely the ECB, and are part of the same internal administrative review procedure in relation to decisions taken by that institution in the exercise of the powers conferred on it by [the SSM Regulation] and that, consequently, they are, as the Advocate General noted in point 98 of his Opinion, inherently linked.

93 Therefore, the General Court was fully entitled, in paragraphs 31, 34 and 128 of the judgment under appeal, to examine the decision at issue in the light of the Opinion of the Administrative Board of Review which, in accordance with Article 24(9) of [the SSM Regulation] and Article 18 [the ABoR Decision], had been notified to the Landeskreditbank.

94 In the present case, the General Court noted that the Administrative Board of Review’s Opinion of 20 November 2014 found that the decision adopted by the ECB on 1 September 2014, which classified the Landeskreditbank as a ‘significant entity’, within the meaning of Article 6(4) of [the SSM Regulation], was lawful, and that, by the decision at issue, the ECB abrogated and replaced that decision, while maintaining that classification.

95 Consequently, after finding, in paragraph 125 of the judgment under appeal, that the Administrative Board of Review’s Opinion was part of the context of which the decision at issue formed a part and could, therefore, under the case-law cited in paragraph 87 of the present judgment, be taken into account for the purpose of determining whether that decision contained a sufficient statement of reasons, the General Court did not err in law when it held, in paragraph 127 of the judgment under appeal, that it necessarily followed from Article 24(1) and (7) of [the SSM Regulation] that, in so far as that decision had ruled in conformity with that opinion, it was an extension of that opinion and the explanations contained therein could be taken into account for the purposes of determining whether the decision at issue contained a sufficient statement of reasons.

96 In that context, the General Court also did not err in law when, for the purposes of determining whether the decision at issue contained a sufficient statement of reasons, in paragraph 128 of the judgment under appeal, it read that decision and the Administrative Board of Review’s Opinion together, from which it held that it was apparent that, first, the ECB had considered that there could be particular circumstances only if attainment of the objectives of [the SSM Regulation] could be better safeguarded through direct prudential supervision by the national

authorities and that, second, the Landeskreditbank had not demonstrated that that condition was fulfilled in that regard.”<sup>115</sup>

It is for another reason, that the CJEU’s **L-Bank** case is important for the SSM, namely the CJEU’s ruling that the SSM Regulation attributes exclusive prudential competences to the ECB which the National Competent Authorities (NCAs) implement in decentralised fashion in respect of LSIs. The following finding by the General Court<sup>116</sup>:

“the logic of the relationship between [Article 4(1) and Article 6 of the SSM Regulation] consists in allowing the exclusive competences delegated to the ECB to be implemented within a decentralised framework, rather than having a distribution of competences between the ECB and the national authorities in the performance of the tasks referred to in Article 4(1) of that regulation.”

“(…) the Council has delegated to the ECB exclusive competence in respect of the tasks laid down in Article 4(1) of the [SSM Regulation] and that the sole purpose of Article 6 of that same regulation is to enable decentralised implementation under the SSM of that competence by the national authorities, under the control of the ECB, in respect of the less significant entities and in respect of the tasks listed in Article 4(1)(b) and (d) to (i) of the [SSM Regulation],”

“under the SSM the national authorities are acting within the scope of decentralised implementation of an exclusive competence of the Union, not the exercise of a national competence.”

was confirmed by the CJEU<sup>117</sup> in this manner:

“(…) it follows from the wording of Article 4(1) of [the SSM Regulation] that the ECB is exclusively competent to carry out the tasks stated in that provision in relation to all those institutions.”

“The national competent authorities thus assist the ECB in carrying out the tasks conferred on it by [the SSM Regulation], by a decentralised implementation of some of those tasks in relation to less significant credit institutions (…).”

---

<sup>115</sup> Paragraph 87 of the judgment of 8 May 2019 in Case C-450/17 P, *Landeskreditbank Baden-Württemberg – Förderbank v ECB*, EU:C:2019:372 sets out the requirements for motivation and reads as follows: “It is also settled case-law that the requirement to state reasons must be assessed by reference to the circumstances of the case, in particular the content of the measure in question, the nature of the reasons given and the interest which the addressees of the measure, or other parties to whom it is of direct and individual concern, may have in obtaining explanations. It is not necessary for the reasoning to specify all the relevant facts and points of law, since the question whether the statement of reasons meets the requirements of Article 296 TFEU must be assessed with regard not only to its wording but also to its context and to all the legal rules governing the matter in question (judgments of 5 December 2013, *Solvay v Commission*, C-455/11 P, EU:C:2013:796, paragraph 91, and of 10 March 2016, *HeidelbergCement v Commission*, C-247/14 P, EU:C:2016:149, paragraph 16).”

<sup>116</sup> Paragraphs 54, 63 and 72 of the judgment of 16 May 2017 in Case T-122/15, *Landeskreditbank Baden-Württemberg – Förderbank v ECB*, EU:T:2017:337.

<sup>117</sup> Paragraphs 38 and 41 of the judgment of 8 May 2019 in Case C-450/17 P, *Landeskreditbank Baden-Württemberg – Förderbank v ECB*, EU:C:2019:372.

The most extensive citations and endorsements of an ABoR opinion by the court can be found in its judgments of 13 December 2017 in the *Arkéa* cases<sup>118</sup>. The General Court<sup>119</sup> strongly confirms the role of ABoR as it imputes to the ECB the reasoning in ABoR opinion in case the second ECB decision is in line with this opinion, and assesses the ECB's motivation for this second decision also on the basis of the ABoR opinion<sup>120</sup>. The Court extensively quotes<sup>121</sup> and endorses<sup>122</sup> the ABoR's findings. Notably, when referring to the ECB's reasons to effect consolidated supervision of the *Crédit Mutuel* group through the central body of this banking group, the *Confédération Nationale du Crédit Mutuel* (CNCM), the General Court notes: "that, if the reasons for which the ECB decided to organise consolidated supervision of the *Crédit Mutuel* group through the CNCM are not explicitly stated in the contested decision, the [ABoR] provided grounds on this point, which have been transcribed in paragraphs 8 to 10 above"<sup>123</sup>.

Other noteworthy proceedings concern *Trasta*<sup>124</sup>, where after the ABoR review litigation ensued on the preliminary issue of the standing of shareholders when contesting the withdrawal of a banking license. The outcome of the cases on this point will be decisive for the scope of access to administrative review by shareholders and other parties indirectly affected by a supervisory act.

Finally, in the cases pitting *Crédit Agricole* against the ECB, the General Court judgment<sup>125</sup> contains references to the ABoR opinion preceding judicial proceedings concerning the separation of the exercise of executive and non-executive functions within a bank's management body<sup>126</sup>. The General Court does not, however, follow the ABoR's reasoning and sets out its own rationale for accepting the ECB's stance that a chairman cannot simultaneously also be the CEO of a credit institution: a bank's good governance requires effective oversight of the senior management by the non-executive members of the management body; this necessitates checks and balances within the management body.

---

<sup>118</sup> Judgments of 13 December 2017 in Case T-712/15, *Crédit Mutuel Arkéa v ECB*, EU:T:2017:900 and in Case T-52/16, *Crédit Mutuel Arkéa v ECB*, EU:T:2017:902; judgment of 2 October 2019, in Joined Cases C-152/18 P and C-153/18 P, *Crédit Mutuel Arkéa v ECB*, EU:C:2019:810.

<sup>119</sup> See <https://ebi-europa.eu/wp-content/uploads/2019/01/Note-on-the-Arke%CC%81a-judgments-for-publication-final.pdf>.

<sup>120</sup> Paragraphs 49 and 50 of the judgment of 13 December 2017 in Case T-712/15, *Crédit Mutuel Arkéa v ECB*, EU:T:2017:900, which largely overlaps with the judgment in Case T-52/16, *Crédit Mutuel Arkéa v ECB*.

<sup>121</sup> Paragraphs 9-11 of the judgment of 13 December 2017 in Case T-712/15, *Crédit Mutuel Arkéa v ECB*, EU:T:2017:900.

<sup>122</sup> Paragraphs 51; 70; 120; 130-131; 147-148; 157-158 of the judgment of 13 December 2017 in Case T-712/15, *Crédit Mutuel Arkéa v ECB*, EU:T:2017:900.

<sup>123</sup> Paragraph 51 of the judgment of 13 December 2017 in Case T-712/15, *Crédit Mutuel Arkéa v ECB*, EU:T:2017:900.

<sup>124</sup> See footnote 97, Order of 12 September 2017 in Case T-247/16, *Trasta Komerbanka and Others v ECB* (renamed as *Fursin and Others v ECB*) EU:T:2017:623, rejecting the claim of Trasta Komerbanka as inadmissible and upholding the shareholders' claim as admissible; appeals by the ECB (C-663/17 P), the Commission (Case C-665/17 P) and by Trasta Komerbanka (Case C-669/17 P) pending. A judgment in the appeal cases is foreseen for 5 November 2019.

<sup>125</sup> Judgment of 24 April 2018 in Joined Cases T-133/16 to T-136/16, *Crédit Agricole v ECB*, EU:T:2018:219.

<sup>126</sup> For a summary of the judgments, see: <https://ebi-europa.eu/wp-content/uploads/2019/01/Cre%CC%81dit-Agricole-Cases-Summary.pdf>.

## 6 Transparency, exposure to citizens' concerns and access to supervisory files

### Transparency as a principle

Transparency is an indispensable element of the rule of law. Without transparency about the conduct of public authorities there can be no accountability: neither in the court of public opinion (parliament, the media), nor before a court of auditors or in a court of law. The Treaty recognises this<sup>127</sup>. As Nikolai Badenhoop and I posit in our joint article discussing recent case law on access to supervisory files<sup>128</sup>: "(...) without adequate information about the conduct to be assessed, whether by the political bodies or the judicial organs, accountability [of the supervisor] is an empty shell". Naturally, transparency needs to be balanced against other public interests<sup>129</sup>, including the confidentiality of decision-making on monetary policy<sup>130</sup> and professional secrecy<sup>131</sup> applying to ECB tasks including to prudential information<sup>132</sup>. This secrecy encompasses business secrets of supervised entities and privacy of natural persons involved.

### Central banks' transparency: recent steps

On the wider issue of transparency and conversations with the general public on a central bank's tasks, I note several developments. The appearance before national parliaments of the President of the ECB, instituted by Mario Draghi, has widened the scope of accountability and included in direct exposure to 'Mr. Euro' the representatives of national electorates<sup>133</sup>. While the focus of accountability must be at the European level, i.e. principally vis-à-vis the European Parliament, as President Draghi has rightly insisted<sup>134</sup>, welcoming others in the process of accountability may

<sup>127</sup> Article 15(1) TFEU: "In order to promote good governance and ensure the participation of civil society, the Union institutions, bodies, offices and agencies shall conduct their work as openly as possible."

<sup>128</sup> René Smits, Nikolai Badenhoop, "Towards a single standard of professional secrecy for supervisory authorities – A reform proposal" (footnote 4).

<sup>129</sup> Regulation (EC) No 1049/2001 of the European Parliament and of the Council of 30 May 2001 regarding public access to European Parliament, Council and Commission documents (OJ L 145, 31.5.2001, p. 43); Decision of the European Central Bank of 4 March 2004 on public access to European Central Bank documents (ECB/2004/3) (2004/258/EC) (OJ L 80, 18.3.2004, p. 42) as lastly amended by Decision ECB/2015/1 of the European Central Bank of 21 January (OJ L 84, 28.3.2015, p. 64) consolidated text at: [https://www.ecb.europa.eu/ecb/legal/pdf/cellar\\_bd68ac81-63eb-44c3-a109-d181b1f0c8ee\\_en\\_txt.pdf](https://www.ecb.europa.eu/ecb/legal/pdf/cellar_bd68ac81-63eb-44c3-a109-d181b1f0c8ee_en_txt.pdf).

<sup>130</sup> Article 10.4 of the ESCB Statute.

<sup>131</sup> Article 37 of the ESCB Statute.

<sup>132</sup> Article 27 of the SSM Regulation.

<sup>133</sup> See: Nicolò Fraccaroli, Alessandro Giovannini and Jean-François Jamet, "The evolution of the ECB's accountability practices during the crisis", ECB Economic Bulletin, Issue 5/2018 (footnote 37).

<sup>134</sup> "Never forget that the ECB is accountable to the European Parliament, not necessarily to the national parliaments. We have accepted invitations that national parliaments have kindly extended to us, but the normal counterparty is the European Parliament", Introductory statement to the press conference (with Q&A), Mario Draghi, President of the ECB, Frankfurt am Main, 6 November 2014, available at: <https://www.ecb.europa.eu/press/pressconf/2014/html/is141106.en.html>.

increase understanding of the central bank's practices and motives, and influence its decision-making.

Further important strides towards more transparency have been undertaken by the ECB in recent years: the publication, since 2015, of discussions in the Governing Council on monetary policy<sup>135</sup>, and the publication, in 2018, of the SSM Supervision Manual<sup>136</sup> and the Guide to on-site inspections and internal model investigations<sup>137</sup> are notable improvements of transparency.

## Direct exposure to citizens: EU and India

Direct exposure to citizens has been endeavoured on this continent through dialogues with youth<sup>138</sup>. In a different, continent-like jurisdiction with much ethnic, religious and linguistic variation, the central bank has experimented with direct discussions with interested citizens. Under Governor Subbarao's (2008-2013), the Reserve Bank of India (RBI) made intentional use of "annual town hall meetings" to reach out to stakeholders: the Board of Governors would convene in another town than at its seat in Mumbai<sup>139</sup> and a public meeting with local citizens would be organised to give the RBI direct exposure to their voice. Such "town hall meetings" are a way of reaching out to key stakeholder groups. They are still in use by the RBI's Financial Inclusion Department to reach out to small and medium-sized enterprises (SMEs). This direct exposure is an exercise in central bank communication, not "the standard one way oral or written communication but to two way communication between the central bank and its stakeholders, with the central bank remaining largely in a listening mode", as former RBI Governor Subbarao eloquently explained<sup>140</sup>.

I consider that such direct exposure, in the local language with instant translation, could be helpful in achieving the two outcomes I mentioned: increasing public understanding of the central bank's tasks and operations and inspiring decision-making here in Frankfurt. The ECB Youth Dialogues are a format that, in my view, could be extended to older people, as well. The recent meeting between the Chair of the Supervisory Board and the Vice Governor of *Banco de Portugal* Elisa Ferreira with young Portuguese financial professionals<sup>141</sup> is an instance of direct communication which deserves to be extended further.

---

<sup>135</sup> *Monetary policy accounts*, available at: <https://www.ecb.europa.eu/press/accounts/2019/html/index.en.html>.

<sup>136</sup> See: [https://www.bankingsupervision.europa.eu/ecb/pub/pdf/ssm\\_supervisorymanual201803.en.pdf](https://www.bankingsupervision.europa.eu/ecb/pub/pdf/ssm_supervisorymanual201803.en.pdf).

<sup>137</sup> See: [https://www.bankingsupervision.europa.eu/ecb/pub/pdf/ssm\\_osi\\_guide201809.en.pdf](https://www.bankingsupervision.europa.eu/ecb/pub/pdf/ssm_osi_guide201809.en.pdf).

<sup>138</sup> See: <https://www.ecb.europa.eu/ecb/educational/youth-initiatives/ecb-youth-dialogue/html/index.en.html>.

<sup>139</sup> I note that the Governing Council also meets annually outside of Frankfurt, in 2020 it will meet in Amsterdam, see: <https://www.ecb.europa.eu/press/calendars/mgocg/html/index.en.html>.

<sup>140</sup> Dilemmas in Central Bank Communication - Some Reflections Based on Recent Experience, Second Business Standard Annual Lecture delivered by Dr. Duvvuri Subbarao, Governor, Reserve Bank of India, at New Delhi on 7 January 2011.

<sup>141</sup> Lisbon, July 2019, see: <https://www.youtube.com/watch?v=kBwe-5QwYIY&feature=youtu.be>.

## Transparency; access to supervisory files

In this contribution, the focus must be on prudential supervision and accountability for this activity. Openness of supervisory files is needed to give account of supervisory actions<sup>142</sup>. Such openness can only be given partially, and depends on the moment in time it is requested. Nicolai and I discern a careful trend in case law towards more opening of files. Several proceedings, relating to different rules in directives applying in the securities markets and banking sectors, have led to a slight relaxation of the occlusion to supervisory data hitherto predominant. There is not yet a 'paradigm shift', called for by Advocate General Bobek in the *Buccioni* case<sup>143</sup>, with transparency much widened in case of 'historic' relevance, i.e. after bankruptcy or resolution of a financial firm. But there is a tendency to consider that, with the passing of a five-year period, documents in a supervisory file lose their secret or confidential nature<sup>144</sup>, unless the party defending its confidential nature can show "that, despite its age, that information still constitutes an essential element of its commercial position or that of interested third parties"<sup>145</sup>. The CJEU has also accepted an exemption to disclosure after five years for "information relating to the supervision methodology and strategy employed by the competent authorities"<sup>146</sup>. It would seem to me that such information belongs to the sort of evidence that outsiders have an interest to see. Such information may be relevant not only when a party challenges supervisory decisions but, also, when a court of auditors or a parliament wishes to hold the supervisor accountable for its activity<sup>147</sup>. I also refer to our colleagues of the Appeal Panel of the SRB who held that an SRB decision rejecting access to information regarding the resolution of *Banco Popular Español* did not fulfil the SRB's obligation to balance confidentiality concerns with overriding public interests<sup>148</sup>.

---

<sup>142</sup> Supervisory Board Chair Andrea Enria has emphasised the importance of transparency, e.g., as regards SREP disclosure to banks: *Public hearing with Andrea Enria, Chair of the ECB Supervisory Board, presenting the SSM Annual Report 2018*; ECON on 21 March 2019, available at: [http://www.europarl.europa.eu/RegData/etudes/IDAN/2019/634391/IPOL\\_IDA\(2019\)634391\\_EN.pdf](http://www.europarl.europa.eu/RegData/etudes/IDAN/2019/634391/IPOL_IDA(2019)634391_EN.pdf) and: *On supervisory architecture*, Panel remarks by Andrea Enria, Chair of the Supervisory Board of the ECB, at the Financial Stability Institute 20th anniversary conference, Basel, 12 March 2019, available at: <https://www.bankingsupervision.europa.eu/press/speeches/date/2019/html/ssm.sp190312~c16ac0912f.en.html>.

On the supervisory dialogue with the European Parliament, see: Fabian Amtenbrink and Menelaos Markakis, *Towards a meaningful prudential supervision dialogue in the Euro area? A study of the interaction between the European Parliament and the European Central Bank in the Single Supervisory Mechanism*, *European Law Review* (44) 2019, pp. 3-23.

<sup>143</sup> See the opinion of Advocate General Bobek in Case C-594/16, *Enzo Buccioni v Banca d'Italia*, EU:C:2018:425, paras 84-87.

<sup>144</sup> Judgment of 19 June 2018 in Case C-15/16, *Bundesanstalt für Finanzdienstleistungsaufsicht v Ewald Baumeister*, EU:C:2018:464.

<sup>145</sup> Judgment of 19 June 2018 in Case C-15/16, *Bundesanstalt für Finanzdienstleistungsaufsicht v Ewald Baumeister*, EU:C:2018:464, paragraph 54.

<sup>146</sup> Judgment of 19 June 2018 in Case C-15/16, *Bundesanstalt für Finanzdienstleistungsaufsicht v Ewald Baumeister*, EU:C:2018:464, paragraph 56.

<sup>147</sup> We concur with the authors of *IMF Working Paper* WP/05/51 that while "publication of bank supervisory decisions and required actions need to be treated with circumspection", "the presumption should be that such decisions and the reasoning behind them will be a matter of public record, even if this disclosure occurs well after the event."; Eva Hüpkes, Marc Quintyn and Michael Taylor, "The Accountability of Financial Sector Supervisors: Principles and Practice" (2005).

<sup>148</sup> SRB Appeal Panel, Final decision from 19 June 2018 on joined cases 44/2017 and 7/2018, available at [https://srb.europa.eu/sites/srbsite/files/case\\_44\\_17\\_7\\_18\\_project\\_decision\\_20180618\\_anonymised.pdf](https://srb.europa.eu/sites/srbsite/files/case_44_17_7_18_project_decision_20180618_anonymised.pdf)

The variability in prudential rules on professional secrecy across the silos of supervision that Europe still applies (banking/securities trading/insurance and occupational pensions), which recent case law made painfully visible, needs to be remedied<sup>149</sup> to ensure similar conduct of supervision across the entire financial sector when it comes to transparency. Harmonising these rules would enable the legislator to modernise the system of access to supervisory files. Hence, our proposal for a single standard of professional secrecy for supervisory authorities.

In our joint contribution, we consider that this standard should “[protect] the confidence between supervisors and supervised, shielding the authorities from having to disclose their considerations in weighing alternatives, and allowing authorities to continue to make use of the surprise effect of supervisory actions”, while also introducing “exceptions for cases covered by criminal and tax law and for proceedings that relate to (but do not necessarily constitute) bankruptcy or resolution proceedings.” We submit that “a general presumption that information loses its confidential nature after a lapse of five years should be adopted, and a reversal of the burden of proof introduced: only if the party affected by disclosure proves the need for continued secrecy after five years would confidentiality of information be upheld.” A single standard of professional secrecy would encompass “the exchange of confidential information not only between different national competent and designated authorities, but also between competent authorities of different subsectors of the financial sector, especially for entities combining banking, investment services and/or insurance business”. The standard would specifically include the European Supervisory Authorities (ESAs) and the ECB. It would “introduce a single set of rules for sharing information with, inter alia, auditors and accountants, with clearing houses, with authorities in the area of anti-money laundering and counter-terrorist financing (AML/CTF) and with bodies responsible for deposit insurance and payment services oversight.” Especially the exchange of information in the area of combatting money laundering and terrorist financing is a topical element of our proposal.

## 7 Concluding remarks

Having placed the role of the ABoR in the context of the rule of law, I have recalled the horrors seen in this very building, long before the establishment of the ECB, and called for a clear recognition of these facts prominently visible for those who enter this building, as a stark reminder of what lay at the origin of the European integration process which culminated in the establishment of the ECB and as an invitation to remembrance and vigilance in these times of attacks on the rule of law: a plaque at the entrance recalling this building’s dark history. Within the context of the rule of law exercise at Union level, I have pleaded for extending the ECB’s input into this on-going process of defending and expanding the rule of law, from enforcement of provisions on its independence to protection of affected parties against its legal acts,

---

<sup>149</sup> Where sector differences justify variations in applicable texts they should be maintained; it is the largely inexplicable discrepancies between the current professional secrecy regimes that we propose to change.

as a vital element of the rule of law for an institution with wide powers affecting citizens and enterprises across the continent. In a democratic society, a public authority, including a central bank cum supervisory authority, should display accountability, responsiveness and transparency (the ART of democracy) on its activities, duly balanced by its constitutionally enshrined independent status and the interests of confidentiality which are dictated by monetary policy and supervisory concerns as well as consideration of business secrets and privacy of affected individuals. This responsiveness requires an open, listening attitude and a willingness to consider issues from a new angle – the recent shifts in the debate about the role of central banks in the area of sustainable finance has shown how quickly positions erstwhile considered outlandish can enter the mainstream approach. The role of the ABoR is one of independent review, assisting to provide due process where this might have been lacking in full in preceding phases of the supervisory proceedings. Where possible, more transparency on the ABoR proceedings would be welcome even though most of the insight into administrative review may have to come from subsequent judicial review. The interaction with judicial proceedings shows the significance attached to the ABoR’s opinions by the CJEU. For such proceedings to be initiated a level of openness, after a certain amount of time, of supervisory files is needed: recent case law provides the prospect of a more open approach on which I would propose to build on in order to establish a financial-sector wide professional secrecy standard. Court proceedings in Luxembourg in banking union-related cases have a wide array of topics as their object. Judicial review is proving to be an indispensable element in the protection of rights under the rule of law.

## 8 Annex

### “Re-interpretation” of the *L-Bank* judgment by the German Constitutional Court

The German Constitutional Court (*BVerfG*) recently found<sup>150</sup> the *L-Bank* judgment of the CJEU compatible with its own reading that the competences of the NCAs remain autonomous national powers and are not derived from European Union competences. It reasoned that a different understanding of the allocation of competences between the ECB and the NCAs would imply that the SSM Regulation would violate the scope of EU integration allowed by the German Constitution and would be contrary to the wording of Article 127(6) of the TFEU and with a systemic reading of the Treaty. This dissimilar interpretation of the legal state of affairs is then aligned with that of the CJEU through a reading of the latter’s judgment as “not giving the ECB overall comprehensive supervisory powers over all less significant institutions” – which, with due respect, was never the reading of the CJEU and the General Court which did hold, however, that the powers over LSIs exercised by NCAs are derived and a decentralised exercise of exclusive ECB competences. The *BVerfG* precedes its considerations on the *L-Bank* judgment with strongly worded

---

<sup>150</sup> Judgment of 30 July 2019, 2 BvR 1685/14, 2 BvR 2631/14.



arguments against exclusive competences for prudential supervision for the ECB. It is noteworthy that the *BVerfG*'s decision relies on the proportionality principle to come to a different reading of the allocation of competences between the ECB and the NCAs, whereas the CJEU had declared the same proportionality principle as not opposing the approach taken by the EU legislature in adopting the SSM Regulation (paragraphs 51-59 of its judgment of 8 May 2019).

The emphasis of the *BVerfG* in its reading of the SSM Regulation, which was challenged before it as an *ultra vires* act of the European legislator which thereby allegedly violated the scope for EU integration that the German Constitution (*Grundgesetz*) allows, is on the shared competences between the Union and the Member States (Article 4 of the TFEU) to which prudential supervision belongs and on the words "specific tasks" in Article 127(6) of the TFEU, which permits conferral to the ECB of supervisory competences (paragraph 186).

A "*Rückdelegation unionaler Verwaltungsaufgaben*" (transfer back of Union administrative tasks), from the ECB to the NCAs, presupposes a complete transfer of prudential competences to the ECB which is not what the SSM Regulation is about and which, moreover, would contradict the primary law basis for this regulation – a different reading of the SSM Regulation would qualify it as an *ultra vires* act (paragraph 187). Banking supervision does not belong to the exclusive competences of the Union in the sense of Article 3(1)(c) of the TFEU ("monetary policy for the Member States whose currency is the euro") and was an exclusive Member State competence from the beginning of Stage 3 of the EMU (1 January 1999) until the SSM Regulation took effect fifteen years later. The silence of 'Maastricht' (1992) and 'Lisbon' (2008) on ECB competences in the area of prudential supervision leads the German Court to conclude: "*Die Annahme einer ausschließlichen Zuständigkeit der EZB für die Bankenaufsicht liegt deshalb fern*", or: "Assuming exclusive ECB competences for banking supervision is therefore improbable (or far removed)" (paragraph 190). Strongly worded is the rebuttal of the assumption of derived national prudential competences by the Luxembourg courts: "Therefore, the SSM Regulation does not establish competences of the national supervisory authorities. On the contrary, it presupposes them and restricts them in scope as regulated by Article 4 and Article 6 of the SSM Regulation" (paragraph 191). Remarking as asides that the SSM Regulation shows 'legislative weaknesses' (as exposed in German legal writing which the *BVerfG* cites) and that one needs to rely on the SSM Framework Regulation to precisely identify what it provides, the German Constitutional Court relies on recitals 5 and 15 of the preamble to the SSM Regulation to find that national competences have not been transferred and that the ECB does not exercise original supervisory powers over LSIs (paragraph 192).

Were the SSM Regulation to be read as transferring prudential supervision competences entirely to the ECB, then it would be an obvious and structurally significant transgression of the integration program, which would deprive Member States of a central area of supervision of the economy; such a reading of the SSM Regulation which is methodologically unacceptable would characterise this legal act as *ultra vires* (paragraph 193).

Focussing then on the *L-Bank* judgment, the *BVerfG* distinguishes the Luxembourg judges' decision saying the case solely concerned the interpretation of "special circumstances" in the provision on how a bank could avoid being labelled significant (and, hence, subject to ECB supervision). "The exclusive power to define the term "special circumstances" which the CJEU recognises the ECB to have requires it to have exclusive supervisory powers with respect to all institutions which, in accordance with the criteria set out in Article of the 6(4)(2) SSM Regulation, are considered significant as such" (paragraph 195). "However", so concludes the German Constitutional Court, "it does not require the ECB to have full supervisory powers, even with regard to credit institutions that are deemed to be less significant according to these criteria, as long as the ECB does not exercise its right under Article 6(5) of the SSM Regulation to assume direct supervisory powers itself." It rounds its readings off with a reference to previous and current practice of prudential supervision with the NCAs being dominant: 21 German banks are subject to ECB supervision and 1,700 fall under *BaFin* supervision (paragraph 196). For all these reasons, there is no manifest violation of the principle of subsidiarity (Article 5(3) of the TEU).

The relevant passage of the press release issued by the *BVerfG*<sup>151</sup> and its English translation read as follows:

*aa) Die SSM-Verordnung sieht eine Zweiteilung der Bankenaufsicht vor. Dabei verbleibt es im Wesentlichen bei der Zuständigkeit der nationalen Behörden, während der EZB lediglich besondere Aufsichtsbefugnisse zukommen, die für eine kohärente und wirksame Politik der Europäischen Union in diesem Bereich entscheidend sind. Der EZB werden dazu bestimmte Aufgaben übertragen, die sie für alle Kreditinstitute in der Eurozone wahrzunehmen hat. Hinsichtlich der übrigen Bereiche wird ihr grundsätzlich nur die Aufsicht für bedeutende Kreditinstitute zugewiesen, während die nationalen Aufsichtsbehörden regelmäßig für weniger bedeutende Kreditinstitute nach Maßgabe der von der EZB erlassenen Verordnungen, Leitlinien und allgemeinen Weisungen zuständig bleiben. Auch in allen nicht von der SSM-Verordnung erfassten Bereichen der Bankenaufsicht verbleibt es bei der Zuständigkeit der nationalen Aufsichtsbehörden.*

*bb) Die nationalen Aufsichtsbehörden üben ihre Befugnisse aufgrund originärer Zuständigkeiten aus und nicht infolge einer Ermächtigung durch die EZB. Eine solche Rückdelegation setzte eine vollständige Übertragung der Aufsicht auf die EZB voraus, die die SSM-Verordnung jedoch gerade nicht vorsieht. Andernfalls läge darin eine offensichtliche und strukturell bedeutsame Überschreitung des Integrationsprogramms, die den Mitgliedstaaten einen zentralen Bereich der Wirtschaftsaufsicht entzöge. Eine solche Auslegung der SSM-Verordnung ist weder mit dem Wortlaut von Art. 127 Abs. 6 AEUV vereinbar noch systematisch vertretbar.*

*Die Entscheidung des Europäischen Gerichtshofs (EuGH) vom 8. Mai 2019 (C-450/17 P Landeskreditbank Baden-Württemberg/Europäische Zentralbank) steht*

<sup>151</sup> "If interpreted strictly, the framework for the European Banking Union does not exceed the competences of the European Union", Press Release No. 52/2019 of 30 July 2019, available at: <https://www.bundesverfassungsgericht.de/SharedDocs/Pressemitteilungen/EN/2019/bvg19-052.html>.

*dem nicht entgegen. Der EuGH bestätigt darin die Auffassung des Gerichts der Europäischen Union (EuG), der EZB sei in Bezug auf die in Art. 4 Abs. 1 SSM-VO genannten Aufgaben eine ausschließliche Zuständigkeit übertragen worden, deren dezentralisierte Ausübung durch die nationalen Behörden im Rahmen des SSM und unter Aufsicht der EZB bei den weniger bedeutenden Kreditinstituten im Sinne von Art. 6 Abs. 4 Unterabs. 1 SSM-VO hinsichtlich einiger dieser Aufgaben durch Art. 6 gestattet werde. Auch sei der EZB die ausschließliche Befugnis eingeräumt worden, den Inhalt des Begriffs „besondere Umstände“ im Sinne von Art. 6 Abs. 4 Unterabs. 2 SSM-VO zu bestimmen, so dass der EZB die ausschließliche Aufsicht hinsichtlich aller Institute zusteht, die nach den Kriterien von Art. 6 Abs. 4 Unterabs. 2 SSM-VO grundsätzlich als bedeutend gelten. Eine umfassende Aufsichtskompetenz der EZB auch bezüglich der – zahlenmäßig weit überwiegenden – weniger bedeutenden Kreditinstitute ist damit unbeschadet des Selbsteintrittsrechts nach Art. 6 Abs. 5 SSM-VO jedoch nicht verbunden. Die bisherige Praxis der Bankenaufsicht bestätigt die vom Senat vorgenommene Auslegung.*

*Da die SSM-Verordnung nur die Aufgaben und Befugnisse auf die EZB übertragen hat, die für eine effektive Aufsicht zwingend erforderlich sind, und angesichts der weiterhin bestehenden umfangreichen Befugnisse der nationalen Behörden, scheidet auch eine offenkundige Verletzung des Subsidiaritätsprinzips aus.*

aa) The SSM Regulation provides for a division of banking supervision between the ECB and national authorities. Essentially, national authorities retain their competences; only specific supervisory powers which are crucial to ensure a coherent and effective implementation of the European Union's policy in this domain are conferred on the ECB. To this end, certain tasks are conferred on the ECB that it must perform for all credit institutions in the euro area. In principle, the ECB is competent only for supervising significant credit institutions, while the national supervisory authorities generally remain competent for supervising less significant credit institutions in accordance with the regulations, guidelines and general instructions adopted by the ECB. In areas of banking supervision that are not subject to the SSM Regulation, national supervisory authorities retain their competences.

bb) The national supervisory authorities exercise their powers on the basis of their primary competences, not on the basis of powers conferred by the ECB. Such a re-delegation of powers by the ECB would entail that all supervisory tasks had fully been conferred on the ECB, which is specifically not what Art. 127(6) TFEU allows and what the SSM Regulation provides. A full conferral of all tasks would exceed the limits of the European integration agenda in an evident and structurally significant manner and would deprive Member States of a central part of their economic governance. Such an interpretation of the SSM Regulation is neither compatible with the wording of Art. 127(6) TFEU nor tenable in light of a systematic analysis.

The decision of the Court of Justice of the European Union (CJEU) of 8 May 2019 (C-450/17 P *Landeskreditbank Baden-Württemberg v European Central Bank*) does not merit a different conclusion. In this decision, the CJEU confirms the view taken by the General Court of the European Union (GCEU) that, with regard to the tasks laid down in Art. 4(1) SSM Regulation, an exclusive competence was conferred on the ECB, the decentralised implementation of which by the national authorities is

enabled by Art. 6 of the Regulation, under the SSM and under the control of the ECB, in relation to less significant credit institutions within the meaning of Art. 6(4) subsection 1 SSM Regulation, and in respect of some of the tasks. The CJEU has held that in addition, exclusive competence is conferred on the ECB for determining the content of the definition of “particular circumstances” within the meaning of Article 6(4) subsection 2 SSM Regulation, granting the ECB exclusive supervisory powers in relation to all institutions that are generally considered significant according to the criteria laid down in Art. 6(4) subsection 2 SSM Regulation. This, however, does not amount to a conferral of comprehensive supervisory powers on the ECB also for the far larger number of less significant credit institutions, the ECB’s right to act on its own initiative pursuant to Art. 6(5) SSM Regulation notwithstanding. Current practice regarding banking supervision confirms the interpretation by the Senate.

A manifest violation of the principle of subsidiarity cannot be found, given that the SSM Regulation only conferred tasks and powers on the ECB which are indispensable for effective supervision, and that national authorities still retain extensive powers.