



ELSEVIER

Contents lists available at ScienceDirect

Comptes Rendus Physique

www.sciencedirect.com



Multiscale NMR and relaxation / RMN et relaxation multi-échelles

Application of field-cycling NMR relaxometry to the study of ultrasound-induced effects in the molecular dynamics and order of mesomorphic materials

Application de la relaxométrie RMN à cycle de champ à l'étude des effets induits par les ultrasons sur la dynamique moléculaire et l'ordre dans les matériaux mésomorphiques

Esteban Anoardo

Facultad de Matemática, Astronomía y Física, Universidad Nacional de Córdoba, and IFEG - CONICET, Ciudad Universitaria, X5016LAE, Córdoba, Argentina

ARTICLE INFO

Article history:

Available online 24 July 2010

Keywords:

Ultrasound
NMR relaxation
Relaxometry
Field-cycling
Nematic
Smectic
Relaxation dispersion

Mots-clés :

Ultrasons
Relaxation RMN
Relaxométrie
Cycle de champ
Nématique
Smectique
Dispersion de relaxation

ABSTRACT

A salient characteristic of nuclear magnetic resonance (NMR) techniques is the possibility to scan nuclear spin evolutions within a broad Larmor frequency range. Special instrumentation was developed to extend nuclear spin relaxation studies up to proton Larmor frequencies in the sub-kilohertz regime, a technique known as field-cycling NMR relaxometry. This article refers to an experimental version where the sample under study is selectively subjected to ultrasonic irradiation. The fact that ultrasound couples selectively to the collective dynamics of liquid crystals, offers new insights for the study of the molecular dynamics in these materials using NMR relaxation.

© 2010 Académie des sciences. Published by Elsevier Masson SAS. All rights reserved.

R É S U M É

Une caractéristique des techniques de Résonance Magnétique Nucléaire (RMN) est la possibilité de suivre l'évolution des spins nucléaires dans une large gamme de fréquence de Larmor. On a développé une instrumentation apte à étendre les études de la relaxation des spins nucléaires jusqu'à des fréquences de Larmor inférieures à 1 kilohertz. Cette technique est la relaxométrie RMN à cycle de champ. Le présent article concerne une version expérimentale dans laquelle l'échantillon étudié est simultanément irradié par des ultrasons. Comme les ultrasons se couplent sélectivement à la dynamique collective des cristaux liquides, cette méthode ouvre des perspectives nouvelles pour l'étude de la dynamique moléculaire par relaxation RMN dans ces matériaux.

© 2010 Académie des sciences. Published by Elsevier Masson SAS. All rights reserved.

1. Introduction

Field-cycling nuclear magnetic resonance (NMR) relaxometry showed to be a useful experimental tool for the study of nuclear spin-lattice relaxation. The time-dependent magnetic field NMR technique becomes particularly interesting within the lowest Larmor frequency limit, where other conventional NMR experiments present severe signal-to-noise ratio degradation. Sophisticated instrumentation has been developed during the last 30 years [1–4]. The technique was successfully

E-mail address: anoardo@famaf.unc.edu.ar.

applied for the study of the molecular dynamics in polymers and liquid crystals (LCs) [5], confined LCs [6], biological membranes [7,8], in the development of contrast agents for magnetic resonance imaging [9,10] and the study of biomolecules containing paramagnetic centers [11].

In this article we briefly discuss fast-field-cycling (FFC) features related to its application to the study of the molecular dynamics in nematic and smectic A liquid crystals, while getting down to the particular case where the spin-lattice relaxation is measured under the simultaneous action of an acoustic ultrasonic field. At first, it would be convenient to address two elemental questions: why FFC experiments in liquid crystals? and, why study NMR relaxation under sonication? In the following, we try to answer these two questions.

Several important differences between a liquid crystalline material and the rest of possible states of the matter are related to the presence of orientational order. This is a natural consequence associated to the fact that liquid crystal molecules show a prominent geometric anisotropy. At both thermotropic and lyotropic mesophases, the orientational order fluctuates. Then we refer to order director fluctuations (ODF), a dynamical process that quenches in the solid state and becomes averaged-out in the liquid.

Relaxation features due to ODF were first theoretically worked out for the nematic phase by Pincus [12]. He predicted a characteristic $\nu^{1/2}$ Larmor frequency dependence for the spin-lattice relaxation time T_1 . Several attempts were reported early after his paper claiming the finding of this frequency dependence by using standard NMR instruments within the MHz frequency range. It was not until 1975 when Wölfel et al. [13], using the FFC method, clearly showed for the first time that Pincus prediction was correct. The ODF mechanism was predominantly manifested within the kHz frequency range, absolutely inaccessible by conventional methods (including rotating frame relaxation, see Ref. [14]). Then FFC relaxometry was later successfully applied to the study of many different bulk and confined liquid crystalline compounds. Today the technique is considered a powerful NMR tool for the study of molecular dynamics in LCs, polymers and confined systems, mainly because the noticeable T_1 relaxation dispersion shown by these materials, the strong differences showed-up by the corresponding dispersions in different mesophases, and the remarkable sensitivity to spatial confinement.

When ultrasound is applied to a thermotropic specimen, it has a clear effect on the director orientation (in complete analogy to the orientational effects produced by magnetic and electric fields). Some time ago we raised the question of which other effects may be induced by an acoustic field. We learnt that ultrasound mainly couples to the collective dynamics, that is, to ODF. This coupling originates in the influence that the thermal gradients generated by local pressure have on the viscoelastic properties of the system. Then, would it be possible to modify the ODF spectrum? Would this have macroscopic effects (for example, the induction of metastable states)? The study of this phenomena is not only rich and fascinating from a basic point of view, it has also technological applications in the field of drug delivery and superlubricants, among others.

2. Basic properties of liquid crystals

We briefly discuss some basic properties of the nematic and the smectic mesophases that are important for the interpretation of the spin-lattice relaxation dispersion. For further reading specialized books about the matter are available, see for example [15–17].

The nematic phase is characterized by a molecular orientational order while lacking molecular positional order. The orientational order defines a director field $\hat{n}(\vec{r}, t)$, depending on space position and time, that indicates the molecular average orientation within a certain space region [18]. The free energy of the nematic phase due to elastic distortions can be expressed as:

$$F = \int \frac{d^3r}{2} [K_1(\nabla \cdot n)^2 + K_2(n \cdot \nabla \times n)^2 + K_3(n \times \nabla \times n)^2] \quad (1)$$

where K_1 , K_2 and K_3 are the elastic constants associated with the splay, bend and twist deformations, respectively. The elastic constants strongly depend on temperature. As the elastic free energy is small compared with thermal energy, relatively weak external forces can easily distort the molecular arrangement. In addition to the orientational order present in nematics, smectic phases exhibit positional order, for instance layered structures in the smectic A phase.

The order parameter for the smectic A phase is defined as the amplitude of a one-dimensional density wave whose wave vector points along the director [16,19]:

$$\rho(\vec{r}) = \rho_0 \left[1 + \frac{1}{2} |\Psi| \cos(q_0 z + \varphi) \right] \quad (2)$$

where $|\Psi|$ is a measure of the strength of the smectic order, ρ_0 is the average density, $q_0 = 2\pi/d$ is the wave vector of the density wave (being d the interlayer distance), φ is an arbitrary phase, and z is the coordinate perpendicular to the planes.

For an ideal smectic A phase, twist and bend elastic distortions are forbidden [19]. For an undistorted smectic, only the splay term of the nematic elastic free energy survives (f_n). Besides this term, the smectic free energy term f_s and the corresponding one to the smectic–nematic interaction should be included in the free energy density expression [16,20]. Then:

$$f = f_n + f_s + f_t \quad (3)$$

where

$$\begin{aligned} f_s &= \alpha(T)|\psi|^2 + \beta(T)|\psi|^4 + \dots \\ f_l &= (\nabla + iq_s \vec{\delta n})\psi * \frac{1}{2M}(\nabla - iq_s \vec{\delta n})\psi \end{aligned} \quad (4)$$

Here, α and β are coefficients in the f_s expansion in powers of ψ . M is a mass tensor with two main components, along $(M_{//})$ and normal (M_{\perp}) to the layers, and $\vec{\delta n} = \hat{n}(\vec{r}) - \hat{n}_0$, being \hat{n}_0 the unperturbed director.

3. Proton relaxation dispersion and effective relaxation mechanisms

We briefly discuss the dominant underlying molecular dynamics that usually drive the spin-lattice relaxation dispersion in thermotropic specimens. A complete treatment of the involved dynamics is outside the scope of the present article. Here we only mention those processes having a protagonic role in the relaxation dispersion of thermotropic liquid crystals while stressing general features of relaxation dispersions.

3.1. Order director fluctuations

The existence of thermal fluctuations cause the director to fluctuate around $\hat{n}(\vec{r})$ turning it dependent on t . NMR relaxation due to ODF originates in the modulation of the dipolar interaction between spin pairs due to the presence of hydrodynamic modes [12,21–23].

Let us consider a nematic sample in the presence of a magnetic field along the z direction. Then $\hat{n}(\vec{r}, t) = \hat{n}_0 + \vec{\Delta n}(\vec{r}, t)$, with $\vec{\Delta n}(\vec{r}, t) = n_x(\vec{r}, t)\hat{i} + n_y(\vec{r}, t)\hat{j}$, and \hat{n}_0 the average director parallel to the z direction.

Neglecting the magnetic interaction, from Eq. (1) we get the change in the free energy caused by elastic deformations:

$$F = \frac{1}{2} \int \left\{ K_1 \left(\frac{\partial n_x}{\partial x} + \frac{\partial n_y}{\partial y} \right)^2 + K_2 \left(\frac{\partial n_y}{\partial x} - \frac{\partial n_x}{\partial y} \right)^2 + K_3 \left[\left(\frac{\partial n_x}{\partial z} \right)^2 + \left(\frac{\partial n_y}{\partial z} \right)^2 \right] \right\} \quad (5)$$

Expanding in Fourier series and rotating the coordinate system, it is possible to write last equation in terms of two uncoupled modes (n_1, n_2) :

$$F = \frac{1}{2} \sum_{\vec{q}} \sum_{\beta=1}^2 K_{\beta}(\vec{q}) |n_{\beta}(\vec{q})|^2 \quad (6)$$

where $K_{\beta}(\vec{q}) = K_{\beta} q_{\perp}^2 + K_3 q_{\parallel}^2$, $\langle |n_{\beta}(\vec{q})|^2 \rangle = \frac{K_B T V}{K_{\beta}(\vec{q})}$, K_B is the Boltzmann constant, T is the temperature, V is the volume and \vec{q} is the wave vector of the hydrodynamic modes.

From various relaxation theories [24–26] we know that the spin-lattice relaxation time due to dipolar coupling interaction is given by:

$$\frac{1}{T_1} = \frac{9}{8} \gamma^4 \hbar^2 [J_1(\omega_L) + J_2(2\omega_L)] \quad (7)$$

where $J_l(\omega) = \int_{-\infty}^{\infty} g_l(\tau) e^{-i\omega\tau} d\tau$, $l = 1, 2$, being $g_l(\tau)$ the correlation function for a given dynamic process, ω the Larmor frequency, γ the spin gyromagnetic ratio and \hbar the Planck constant over 2π .

At the low angle approximation ($|\vec{\Delta n}(\vec{r}, t)| \ll |\hat{n}_0|$), it can be demonstrated that $J_2(2\omega_L) \ll J_1(\omega_L)$, and:

$$J_1(\omega) = 3 \frac{K_B T}{16\pi^3} \sum_{\alpha=1}^2 \int \frac{d^3 q}{(K_{\alpha}(\vec{q}))^2 + \eta_{\alpha}^2 \omega^2} \quad (8)$$

In this last equation η_{α} are viscosity constants. Then we integrate over a cylindrical or ellipsoidal volume while considering that the minimum wavelength is associated with molecular dimensions:

$$\int_q d^3 q \rightarrow \int_0^{2\pi} d\phi \int_0^{q_{zh}} dq_z \int_0^{q_{\perp h} \sqrt{1 - \frac{q_z^2}{q_{zh}^2}}} q_{\perp} dq_{\perp} \quad (9)$$

where q_{zh} and $q_{\perp h}$ are the parallel and perpendicular associated cut-off wavelength, and ϕ is the azimuthal angle.

Integration of Eq. (8) conduces to a general expression [27] that, in the simplified nematic one constant approximation (isotropic viscoelastic properties) and assuming $(K/\eta)q_h^2 = \omega_h \gg \omega$ (i.e. within a Larmor frequency window far below from the high frequency cut-off), the result reduces to the Pincus' law for nematic dispersion: $T_1^{ODF}(\omega) \propto \sqrt{\omega}$.

The smectic A phase can be approximated from the nematic case in the limit $K_3 \ll K_1 = K_2$. Under this assumption the model reduces to a linear frequency dependence [27] $T_1^{ODF}(\omega) \propto \omega$. The same frequency dependence may be obtained from the assumption that only the splay term and the local fluctuation of the layers are present in the smectic A elastic free energy [28]. A more refined model can be obtained by including additional terms in the smectic free energy (see Eq. (3)). In this case [29]:

$$T_1^{ODF}(\omega) \propto \left(\frac{\eta_1}{D^{1/2}K_1^{3/2}}Y_1 + \frac{\eta_2}{D^{1/2}K_3^{1/2}K_2}Y_2 \right)^{-1} \quad (10)$$

with

$$Y_1 = \frac{B}{D} \int_0^1 \frac{dx}{x \left(\frac{B}{D}(1-x^2) + \frac{K_3}{K_1}x^2 \right)^{3/2} \sqrt{1 + \sqrt{1 + \frac{1}{x^4} \left(\frac{\omega}{\omega_{s1}} \right)^2}}$$

$$Y_2 = \frac{1}{\sqrt{1 + \sqrt{1 + \left(\frac{\omega}{\omega_{s2}} \right)^2}}$$

$$B = \frac{\psi_0^2 q_s^2}{M_{//}}, \quad x = q_z/q_{zh}, \quad D = \frac{\psi_0^2 q_s^2}{M_{\perp}}, \quad \omega_{s1} = \frac{D}{\eta_1} \quad \text{and} \quad \omega_{s2} = \frac{D}{\eta_2}$$

ψ_0 being the equilibrium value of the smectic order parameter. In contrast with the simplified models conducing to a linear dependence, in this case the resulting dispersion crosses over from ω^0 to $\omega^{0.5}$.

3.2. Self-diffusion

The theory of translational diffusion for isotropic liquids [30] was directly used in the analysis of the relaxation dispersion in LCs [31,32]. Later, modified versions of Torrey's model were proposed for nematics [33] and smectic A structures [34]. Both models predict a flat dispersion in a frequency range where $\omega\tau \ll 1$, being τ the correlation time associated with the self diffusion process.

3.3. Molecular reorientations

Compared to isotropic liquids, the unique relevant difference remains in connection with the anisotropic nature of the media, which usually demands one to consider more than one correlation time for a given process. Internal motions and configurational molecular fluctuations are mainly due to molecular flexibility and rotations of internal groups. These processes are, in general, fast and usually manifests in the relaxation dispersion at high frequencies. At the simplest case, these contributions may be represented by a sum of BPP-type terms with their associated correlation times [35].

3.4. Proton FFC relaxometry in liquid crystals

The proton spin-lattice relaxation dispersion in liquid crystals can be interpreted in terms of collective fluctuations and individual molecular motions like self-diffusion or molecular reorientations. Usually, time scale separation arguments are feasible, and the collective dynamics can be assumed statistically independent of the individual molecular dynamics. ODF and translational diffusion are coupled, but this fact can be considered by introducing a correction in the ODF spectral density [12]. Individual contributions may be hardly discriminated in the relaxation dispersion unless the explored frequency range is extended up to a Larmor frequency well above the inverse of the involved correlation times. Consequently, in the most simple case, the effective relaxation rate can be approximated by the sum of two different contributions: $(T_1)^{-1} = (T_1^{ODF})^{-1} + (T_1^M)^{-1}$, where T_1^M stands for the individual molecular dynamics.

The typical $\omega^{1/2}$ law for nematics (Pincus) was first observed in PAA (*p*-azoxyanisole) [13]. Studies were later extended to very low frequencies as well as other compounds [31,36–38]. A revision of these experiments is currently in progress. Scanning the spin-lattice relaxation at the *ultra low frequency* (ULF) limit demands of two new insights: an improved low-frequency magnetic field compensation [39,40], and the study of local fields by other experimental set-up avoiding the cycle of the magnetic field [41]. Summarizing, from experimental facts we may observe:

- For nematics, the typical square root law is found to be dominant in the T_1 dispersion within the kHz frequency range;
- In the MHz range, individual molecular motions tend to be dominant;
- At the low frequency end of the dispersion, the behavior may depend on different parameters related to the hardware setting and the nature of the local fields;
- The low frequency plateau is mainly due to the unavoidable presence of the local fields, usually masking physical information associated to the low-frequency cut-off of the ODF contribution.

In the smectic A case, the typical relaxation dispersion shows nearly frequency independent until a minimum critical frequency around 20 kHz, where a noticeable steep down dispersion appears up to a very low frequency plateau. The steep dispersion was currently attributed to ODF through an ω^1 dispersion law, while the low frequency plateau, usually between 300 and 800 Hz, interpreted in terms of the cut-off of the ODF modes. Between 30 kHz and about 10 MHz, the T_1 frequency dependence is minor. This behavior was usually attributed to individual motions with a dominant role of the translational diffusion. It has been recently shown that the strong dispersion observed in the low frequency regime in the smectic A phase cannot be directly attributed to ODF. A conjunction of experimental limitations and the strong local fields present in smectic phases seems to dominate the magnetization evolution, thus masking the relaxation effects [42].

4. Ultrasound effects

In the presence of ultrasound, density fluctuations drive a coupling between ODF and the acoustic field. This phenomenon constitutes a tantalizing problem considered many times in the literature [43–46]. A fundamental task for the interpretation of sonication effects in the spin-lattice relaxation was the understanding of the interaction mechanism between the acoustic field and the mesophase director. It was already anticipated that the acoustic field has an orienting action on the nematic director field [47,48]. However, the nature of the interaction was later elucidated for the nematic mesophase from T_1 relaxometry experiments [49] and optical methods [50]. We will consider now how relaxation dispersions driven by ODF become sensitive to sonication.

The experimental set-up consists of a glass sonotrode directly immersed in the sample (located within the magnet of the field-cycling relaxometer, see Fig. 1) [51]. The sonotrode is connected to a piezoelectric bank device driven by an electronic ultrasound generator. No galvanic contact between the electro-acoustic device and the field-cycling instrument was possible. Due to the ultrasound-induced heat in the sample, temperature must be controlled by measuring it directly within the sample volume. Sonication power ranged from 3 to 23 W/cm². Ultrasound frequency was fixed to 30 kHz.

4.1. Nematic phase

No specific effect occurs when the proton resonance frequency crosses the sound frequency of 30 kHz. The interpretation is that the sound energy is immediately dissipated among the whole spectrum of collective modes. It appears that there is no way to enhance a certain mode by coupling it to a monochromatic sound wave. On the contrary, the coupling affects the dispersion in the whole frequency range. A discussion of the theory behind can be found in Refs. [49,52]. Here we briefly comment main aspects.

For a simple description, only ultrasonic waves with wave vector parallel and perpendicular to the director will be considered. Signs between parenthesis correspond to perpendicular waves. The interaction energy between an acoustic wave and the mesophase director \vec{n} is given by [49,50]:

$$f_a = \frac{1}{2}a^2(\vec{k} \cdot \vec{n}) \quad (11)$$

where \vec{k} is the acoustic wave vector, $a^2 = \frac{\xi_n I \rho}{v^3}$, I being the ultrasound intensity, ρ is the average density, v is the sound velocity and ξ_n is the coupling constant between the director field and the acoustically-induced density gradients, here defined as the nematic acoustic susceptibility. The last equation results after averaging over fast oscillations of the ultrasonic waves.

If an ultrasound wave propagates across the liquid crystalline media parallel (perpendicular) to the magnetic field, the fluctuations of the local director decrease (increase) f_a by:

$$\Delta f_a = -(+) \frac{1}{2}a^2(n_x^2 + n_y^2) \quad (12)$$

Adding this free energy term to Eq. (5), a closed expression for the modified dispersion ($T_1^{ODF+S}(\omega)$) can be obtained. In the simplified nematic one-constant approximation, this result reduces to [49]:

$$T_1^{ODF+S}(\omega) \propto \frac{\sqrt{\sqrt{1 + (\omega\tau_0)^2} - (+)1}}{\sqrt{\tau_0}} \quad (13)$$

In the last equation, $\tau_0 \equiv \frac{\eta}{a^2}$, η being the effective viscosity.

It can be seen that in the limit of zero acoustic intensity ($a \rightarrow 0$, $\tau_0 \rightarrow \infty$), the result tends to the typical dispersion for a non-sonicated specimen, that is, Pincus' law. Parallel sound waves enhance the relaxation by ODF while the opposite behavior is observed for normal incidence. Clearly, the experimental set-up shown in Fig. 1 corresponds to a case where the acoustic wave vector and the magnetic field are nearly parallel. The model is based on the following assumptions: (a) the existence of a preferential macroscopic orientational order induced by the magnetic field; (b) time averaging over fast oscillations of the density; and (c) the sound power (specially in the case of parallel irradiation) is low enough to prevent a violation of the low angle approximation and cavitation effects. The first assumption will only be fulfilled at very low

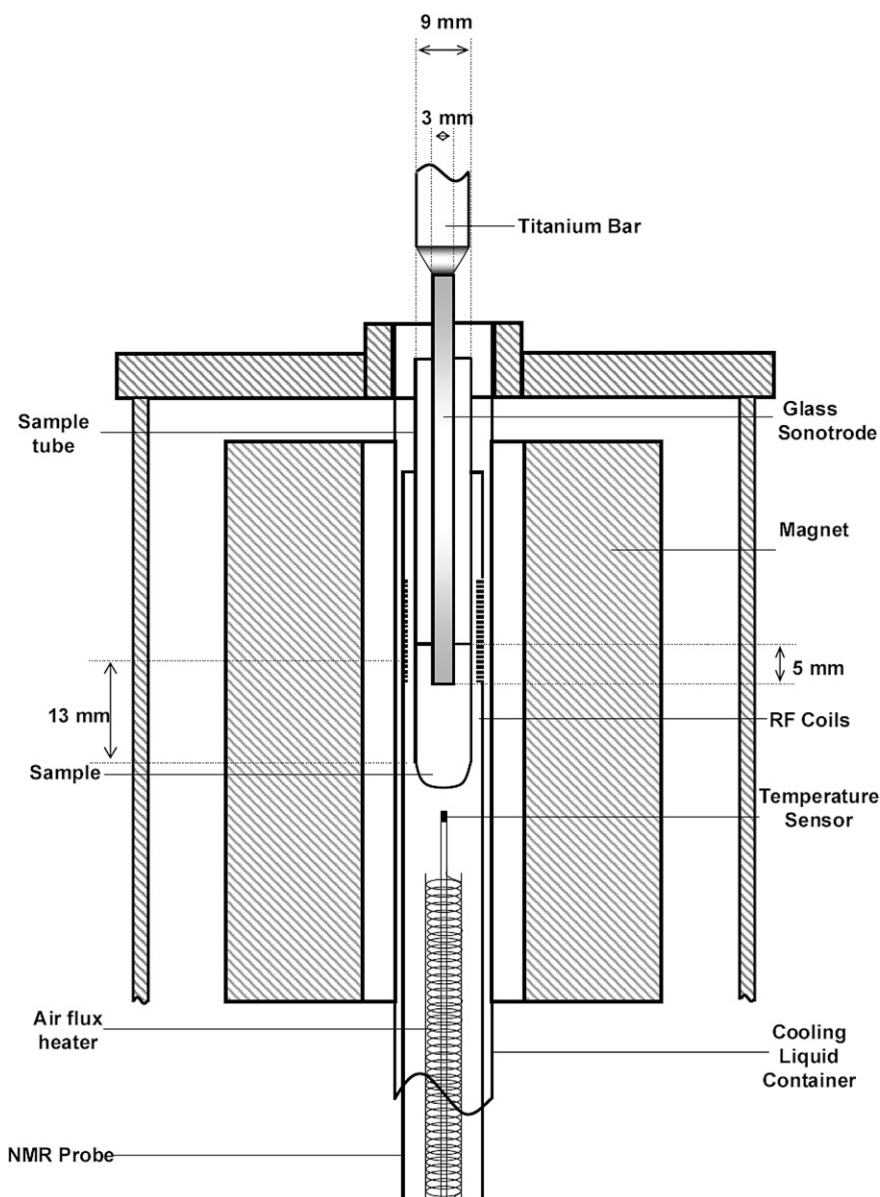

Fig. 1. Experimental set-up used for FFC experiments with simultaneous ultrasonication. The glass sonotrode is directly immersed in the sample volume for an efficient acoustic power deposition. The temperature sensor included in the schematic is part of the temperature control unit. During experiments, temperature is measured directly in the middle of the sample volume.

acoustic power, that is, in consistency with the last. However, if the acoustic interaction becomes dominant, the mesophase director orientation will be strongly influenced by the acoustic field.

The model resulted to be consistent with experimental data obtained in the nematic phase [49,51]. A typical result can be observed in Fig. 2.

4.2. Smectic A phase

A simplified approach for the smectic A phase can be obtained from the nematic case in the limit ($K_3 \ll K_1 = K_2$). However, in this limit, the predicted behavior of the relaxation dispersion turned to be inconsistent under sonication. The expression for T_1 becomes complex when the smectic essence of the problem is incorporated in the analysis, that is, when the coupling between the smectic order and the acoustic field is considered. Theoretical details can be addressed at Ref. [52]. In the limit of zero acoustic intensity, the complete description including the coupling between the smectic order and the acoustic field tends to Eq. (10). This refined model successfully explained the observed T_1 dispersions in the smectic A phase [53]. The frequency dependence of those contributions due to individual relaxation mechanisms and those associated

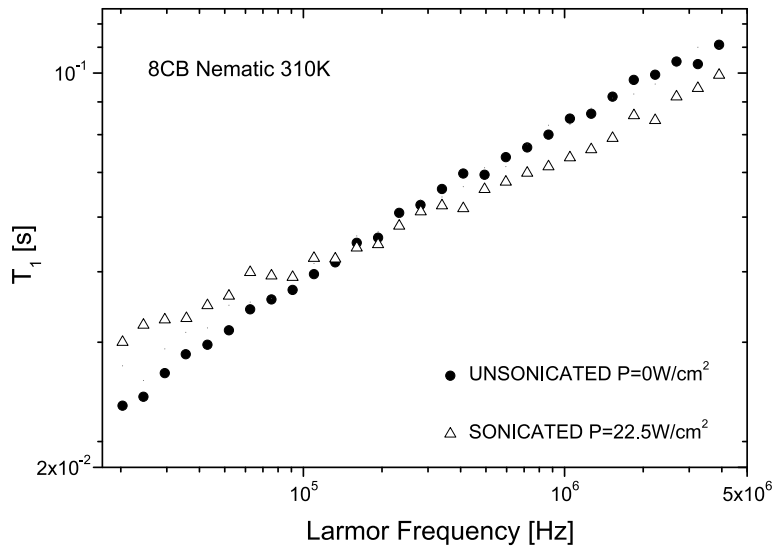

Fig. 2. Typical response of the T_1 relaxation dispersion under sonication for a nematic specimen. Under sonication the dispersion tends to flatten.

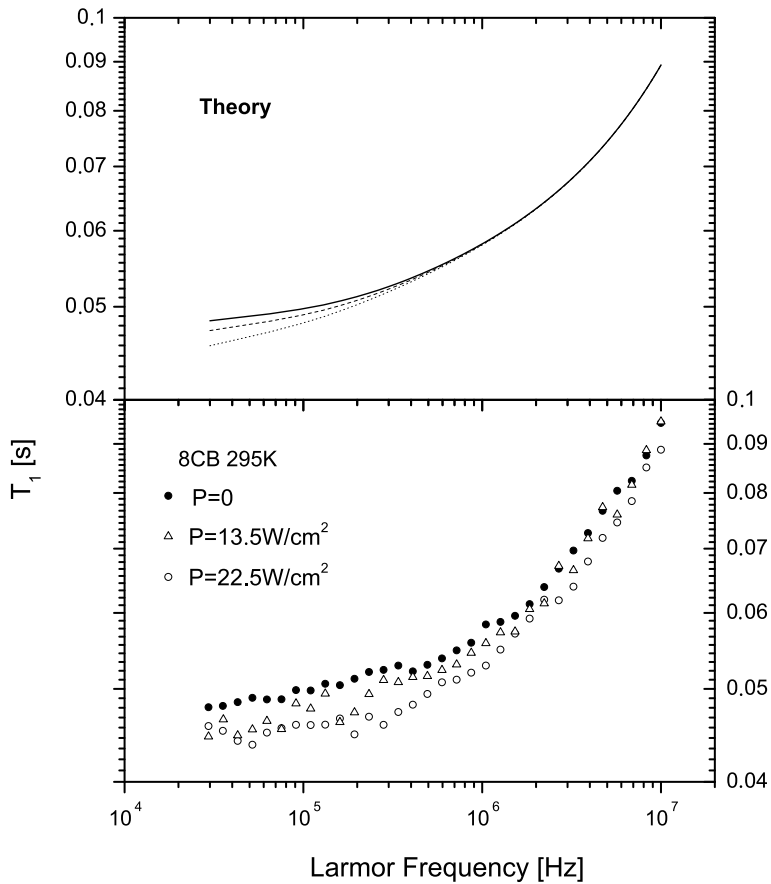

Fig. 3. Typical response of the T_1 relaxation dispersion in the smectic A phase at different acoustic power intensities. For comparison, theoretical and experimental curves are presented. For further details see Refs. [52,53].

to ODF cannot be directly discriminated in the dispersion. This limitation can be circumvented by the fact that only ODF couple with the ultrasonic field thus enhancing its relative contribution to the relaxation dispersion. Fig. 3 shows the typical result for a smectic A phase.

Even when the smectic nature of the problem was included in the free energy through a Ginzburg–Landau expansion in terms of the smectic order parameter, the acoustic interaction remained to be that of the nematics. Then we considered a further refinement of the model by including the interaction energy between the acoustic field and the smectic layers [54]. The smectic A phase can be considered as a three-dimensional nematic with a one-dimensional density modulation. This density modulation is usually interpreted as a molecular packing arranged within equidistant planes (called smectic layers). Within this picture, a new hydrodynamic variable is needed: the displacement of the layers $u(\vec{r}, t)$. This new variable describes the deformation of the smectic structure as a consequence of thermal fluctuations, or any other external perturbation. When sound is applied to the smectic structure, the density modulation will be affected by compressional waves. Even in the absence of sound-induced dislocation effects, new density gradients will affect the spatial and temporal dependence of $u(\vec{r}, t)$. If a sound component is applied along the normal of the smectic layers, a sound-induced compressional gradient will appear.

Since u is a hydrodynamic variable linked to broken translational symmetry in the smectic phase, in analogy to the nematic case, we can contract $n_i n_j$ with a tensor containing information about the u spatial dependence:

$$f_s = \zeta_s n_i n_j (\partial_i \partial_j u) + \xi_s n_i n_j (\partial_i u) (\partial_j u) \quad (14)$$

where f_s is now the interaction energy between the acoustic and director fields in the SmA phase, and ξ_s , ζ_s are the corresponding smectic acoustic susceptibilities. After expanding the second term and averaging over rapid oscillations, we recover the result for a nematic specimen, that is, Eq. (11) [54]. This result reveals that the obtained interaction is based on the same mechanism proposed for the nematic case. It is reasonable if we consider that sound-induced u -gradients can also be related to sound-induced density gradients. This result validates the use of the nematic-like sound–director interaction energy in the smectic A phase, as was previously proposed in Refs. [52,53]. Like in the nematic case, the interaction depends on the acoustic susceptibility ξ_s (now corresponding to a smectic phase). The smectic nature of the problem was introduced through the undulation amplitude.

If the acoustic propagation is nearly parallel to the mesophase director, it can be shown that [54]:

$$a^2 \approx \frac{\xi_s p_0^2}{\rho^2} \frac{1}{(\omega_k^2 - \omega^2)^2} \quad (15)$$

where p_0 is the effective pressure amplitude, ω is the acoustic frequency and ω_k is the frequency associated to a propagating eigenmode of the smectic system. $p_0^2 \propto I$ and $p_0 = p_0(\theta)$, θ being the angle between \vec{n} and \vec{k} . The last equation suggests that if the frequency ω of the external acoustic source matches the frequency ω_k of a propagative eigenmode, the acoustic–director interaction can be enhanced even at moderate acoustic power. We call this condition *hydrodynamic resonance*. In particular, a^2 becomes divergent at resonance if \vec{k} and \vec{n} are parallel, that is, when the acoustic field enhances the order director fluctuations. The calculation of a^2 can be still refined by introducing a more complete description of the smectic material. The divergence disappears if the damping of the excited modes is considered. However, the basic result will be the same: the acoustic–director interaction can be enhanced if the external acoustic field matches an eigenmode of the smectic system.

Fig. 4 shows the influence of the term containing a^2 in the frequency dependence of T_1 close to a low-frequency eigenmode for the same parameters as used in Ref. [52]. The result suggests that the low-frequency dispersion of T_1 may be sensitive to possible hydrodynamic resonances.

The hydrodynamic theory of liquid crystals predicts the existence of propagative acoustic modes in the bulk [16,55]. However, the theoretical analysis of eigenmodes has been more discussed within the frame of smectic films. Experimental evidence was reported during the last years. A propagative shear mode (low-frequency second sound) of about 50 kHz was detected in octyloxy cyanobiphenyl (8OCB) using light scattering under acoustic irradiation [56]. The existence of propagating hydrodynamic modes were also observed in films of 100–200 nm thickness of 4-*n*-4'-octylcyanobiphenyl (8CB) [57]. Propagative underdamped and overdamped modes were found in cyanobiphenyl films of 90–240 nm using proton correlation spectroscopy (PCS) [58]. Therefore, the existence of different propagating modes in SmA films is proven, although no clear experimental evidence exist for the detection of hydrodynamic modes in the bulk. In this case, we are confident that the experimental technique here presented could provide some insights in the near future.

5. Magnetoacoustic manipulation of ordered states in nematics

It is well known that the combined action of orienting fields can induce metastable ordered states in nematics. Studies of this sort are usually performed in electrooptic cells and using optical experiments. Processes like those taking place in Fréedericksz transitions of surface-oriented nematics under the action of a magnetic field may lead to the formation of spatially periodic structures or “inversion walls” as a consequence of spontaneous symmetry breaking [59,60]. Wrinkled nematic states of this sort may also be created by electric fields due to electric conduction [61], or combining the action of electric and magnetic fields [62]. In general, these states have a metastable character (memory capacity) [59,63]. The extension of these studies to the bulk prevents the use of standard optical methods. It was recently shown that FFC relaxometry may be sensitive to metastable states in the bulk as induced by combining a pulsed magnetic field and an amplitude modulated acoustic field [64].

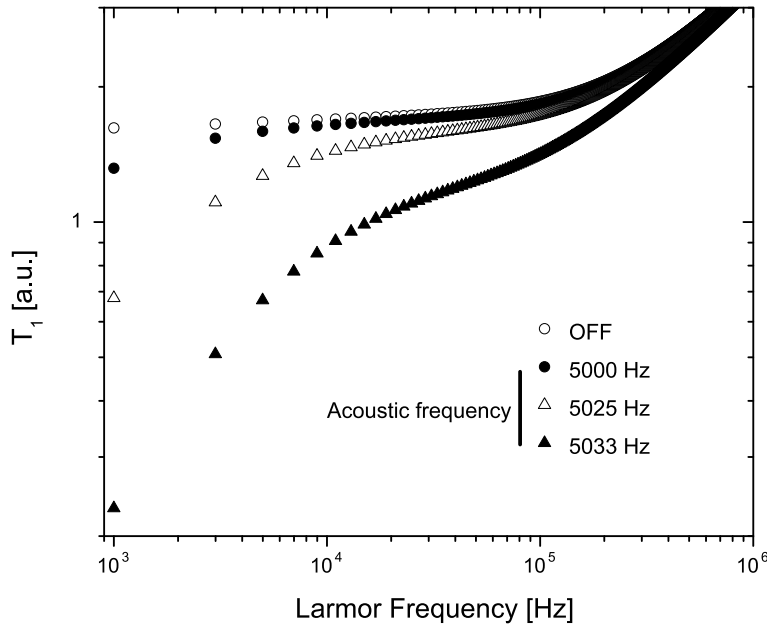

Fig. 4. Simulation of the T_1 relaxation dispersion in the smectic A phase with a^2 defined by Eq. (15). Different curves correspond to the unsonicated case, and for different frequencies of the acoustic frequency close to an eigenmode of the smectic arrangement.

The mean square amplitude of the hydrodynamic modes in the presence of sound, as derived from the equipartition theorem can be expressed as:

$$\langle |n_\alpha(\vec{q})|^2 \rangle = \frac{K_B T V}{f(\vec{q}) - \beta I} \quad (16)$$

where $n_\alpha(\vec{q})$ are the uncoupled hydrodynamic modes appearing in Eq. (6). For convenience, we define $\beta = 2\xi \rho_0 s^2 / v^3$ and $f(\vec{q}) = Kq^2 + (\Delta\chi / \mu_0) B^2$ with the magnetic flux density B , the average elastic constant K , the anisotropy $\Delta\chi$ in the magnetic susceptibility and the vacuum magnetic permeability μ_0 . In contrast to Eq. (6), now the denominator contains a destabilizing term associated to the acoustic interaction, and a stabilizing term due to the magnetic field. Without considering the wave vector dependence of the viscosities ($\eta_\alpha(\vec{q})$), the viscoelastic relaxation time for the hydrodynamic modes can be expressed as:

$$\tau_\alpha(q) = \frac{\eta_\alpha}{f(q) - \beta I} \quad (17)$$

The last two equations suggest that if the acoustic field intensity is modulated in amplitude, a range of q -modes can be kept excited, thus adding an additional instability to the mesophase (equivalent to an increase in temperature). Detection of such instabilities using FFC is a matter of interest, particularly if different transient or metastable ordered states and the corresponding time evolution can be studied in the bulk.

When the orienting action of the acoustic field is dominant, the director tends to be aligned orthogonal to the acoustic wave vector. This last result may depend on the acoustic susceptibility of the material, but it is the case for cyanobiphenyls and other standard compounds. For an experimental set-up like in Fig. 1, when the acoustic interaction prevails, the nematic director and the magnetic field may become orthogonal. In this case the T_1 dispersion is expected to be shifted to lower values [65] (see Fig. 5). In this limit, amplitude modulation of the acoustic field intensity has a negligible effect [64].

The transition to a different order state may be detected through a different T_1 dispersion tendency. Fig. 6 shows a typical experiment of this sort starting from an acoustically ordered state (that is, the mesophase director ordered by the acoustic field) at a temperature of 303 K and an acoustic power of $(3.0 \pm 0.2) \text{ W/cm}^2$. At first the dispersion was measured without sonication. Under unmodulated sonication the T_1 dispersion shifts to slightly lower values, indicating that part of the molecules are restoring the acoustically ordered state. The system keeps memory to its previous acoustically ordered state, in spite of the fact that a whole dispersion was measured in the middle time without sound (several magnetic pulses in between). A pure magnetically ordered state can only be obtained after heating up to the isotropic state. In both cases however, the measured dispersions follow the typical nematic behavior. When a new experiment was done (without erasing memory of the molecular order) including amplitude modulation of the acoustic field, the dispersion changed abruptly to a new ν_0^x -law with $x = (0.16 \pm 0.05)$.

This last result can be explained in terms of contributing acoustic and magnetic torques critically affecting the conditions that minimize the system energy. Clusters surviving within the acoustic domain, i.e., spatial regions where the acoustic

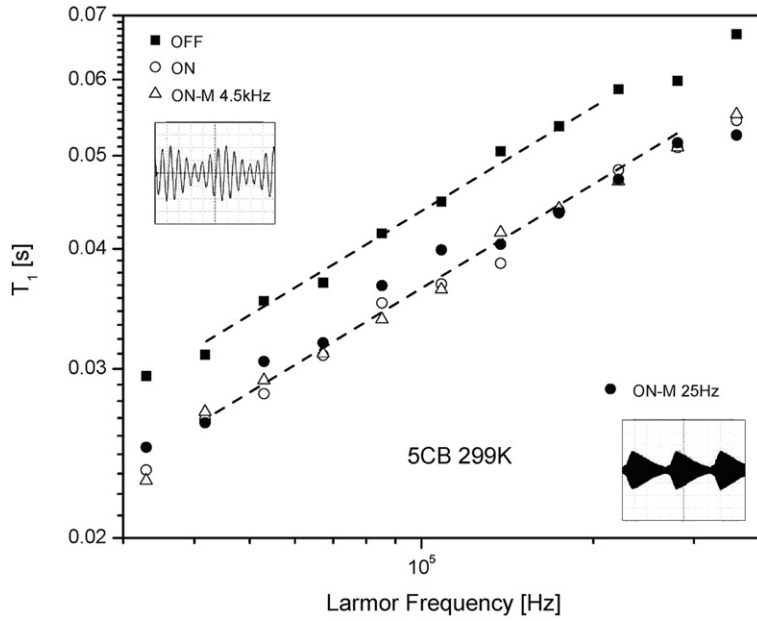

Fig. 5. Typical shift of the T_1 dispersion to lower values due to the orienting action of the ultrasound. At a strongly acoustically ordered state, modulation effects are negligible. In this experimental sequence, the order of the different steps is critic. In the present case, the first dispersion was measured without sonication (filled squares). Then, the experiment was repeated by sonicating the sample at a power of 3 W/cm^2 (open circles). Finally, the experiment is reproduced two more times by modulating in amplitude (sine modulation at 4.5 kHz and saw-tooth at 25 Hz), without showing a substantial effect.

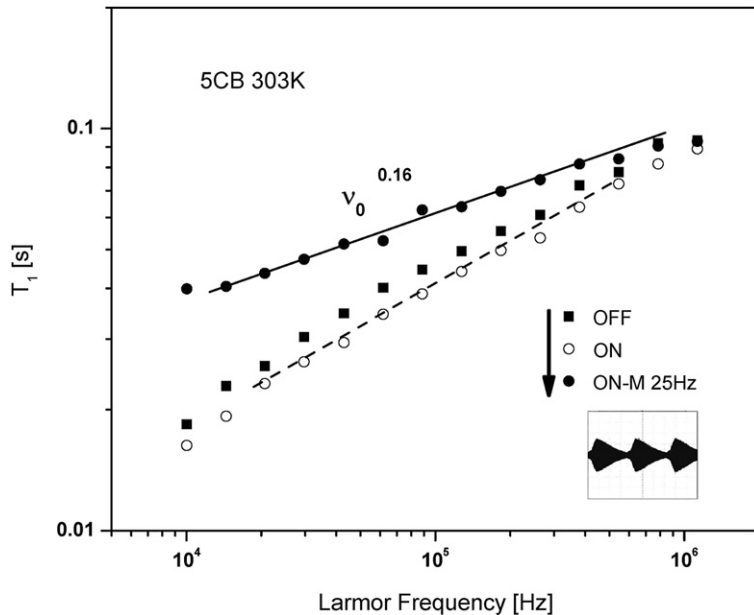

Fig. 6. Same experiment as described in Fig. 5, but at a higher temperature. As a consequence of the amplitude modulation the dispersion changes to a new tendency following a $\nu_0^{0.16}$ -law (see text for details).

interaction is dominant (close to the sonotrode radiating surface), act as memory kernels that restore the acoustic order in the presence of sound, even after a time the nematic was subjected to a pulsed magnetic field. On such clusters the acoustic torque will be huge and with an extremely short reorientational time. On the contrary, in regions where the magnetic field prevails (close to the sample container walls) the system preserves a magnetically ordered state, and in consequence the average acoustic torque will be weak. At the temperature of the experiment, the magnetic reorientational time becomes comparable to the length of the magnetic field pulses. This means that the director partially orders with the magnetic field within the magnetic domain region. The region in between offers the conditions for a transition to a different ordered state.

Since the existence of orthogonal torques is an essential feature of two-dimensional metastable states, the observed changes in the T_1 dispersion may be associated to a three-dimensional version of the same phenomenon. Topological defects may also be induced under the conditions of the cited experiments [66]. However, experimental work in progress using optical methods in glass cells of increasing thickness, shows that metastable ordered states can be obtained with electric fields in the bulky limit of the cell thickness [67]. Such states in the bulk usually evolve from a random defect network.

6. Outlook

The study of NMR relaxometry with simultaneous acoustic perturbation offers plenty of possibilities to explore hydrodynamic and viscoelastic properties of mesomorphic systems. The extension of these studies to biological systems is of huge interest. The previous understanding of the non-sonicated relaxation dispersion and the underlying molecular dynamics are unavoidable prerequisites for the study of NMR relaxation under sonication in a given molecular system. The application of the method to liposomes and bio-membranes is in progress [8].

Hardware development is also open for innovations. Special probes may be still designed to optimize power acoustic transmission and sample temperature control. Special features concerning optimal magnetic and acoustic synchronisms are still unclear. Finally, acoustic generators and transducers allowing amplitude and frequency modulation are not easily available.

The acoustic manipulation of the nematic director offers an efficient and simple alternative to other used methods for angular-dependent NMR experiments. At relative low power (less than 25 W/cm²), the acoustic torque (within the kHz regime) is usually dominant over the magnetic torque (at about 0.5*T*). Of course, possibilities depend on the relative signs of acoustic and magnetic susceptibilities.

References

- [1] F. Noack, *Prog. NMR Spectrosc.* 18 (1986) 171.
- [2] R.-O. Seitter, R. Kimmich, in: J.C. Lindon, G.E. Tranter, J.L. Holmes (Eds.), *Encyclopedia of Spectroscopy and Spectrometry*, Academic Press, London, 1999, p. 2000.
- [3] E. Anardo, G. Galli, G. Ferrante, *Appl. Magn.* 20 (2001) 365.
- [4] G. Ferrante, S. Sykora, *Adv. Inorg. Chem.* 57 (2005) 405.
- [5] R. Kimmich, E. Anardo, *Prog. NMR Spectrosc.* 44 (2004) 257.
- [6] F. Grinberg, M. Vilfan, E. Anardo, in: E.E. Burnell, C.A. de Lange (Eds.), *NMR of Ordered Liquids*, Kluwer Academic Publishers, Amsterdam, 2003, p. 375.
- [7] E. Rommel, F. Noack, P. Meier, G. Kothe, *J. Phys. Chem.* 92 (1988) 2981.
- [8] C.J. Meledandri, J. Perlo, E. Farrher, D.F. Brougham, E. Anardo, *J. Phys. Chem. B* 113 (2009) 15532.
- [9] S. Aime, M. Botta, M. Fasano, E. Terreno, *Chem. Soc. Rev.* 27 (1998) 19.
- [10] M. Rohrer, H. Bauer, J. Mintorovitch, M. Requardt, H.-J. Weinmann, *Invest. Radiol.* 40 (2005) 715.
- [11] I. Bertini, C. Luchinat, *Coord. Chem. Rev.* 150 (1996) 1.
- [12] P. Pincus, *Solid State Commun.* 7 (1969) 415.
- [13] W. Wölfel, F. Noack, M. Stohrer, *Z. Naturforsch.* 30a (1975) 437.
- [14] E. Anardo, F. Grinberg, M. Vilfan, R. Kimmich, *Chem. Phys.* 297 (2004) 99.
- [15] G.R. Luckhurst, C.A. Veracini (Eds.), *The Molecular Dynamics of Liquid Crystals*, Kluwer, Dordrecht, 1994.
- [16] P.G. De Gennes, J. Prost, *The Physics of Liquid Crystals*, Clarendon Press, Oxford, 1994.
- [17] D. Demus, J. Goodby, G.W. Gray, H.W. Spiess, V. Vill (Eds.), *Physical Properties of Liquid Crystals*, Wiley-VCH, Weinheim, 1999.
- [18] F.M. Leslie, *Quart. J. Mech. Appl. Math.* 19 (1966) 357.
- [19] R. Schaetzing, J. Litster, *Adv. Liq. Cryst.* 4 (1979) 147.
- [20] P.G. De Gennes, *Solid State Commun.* 10 (1972) 753.
- [21] R. Blinc, D.L. Hogenbloom, D.E. O'Reilly, E.M. Peterson, *Phys. Rev. Lett.* 23 (1969) 969.
- [22] J.W. Doane, J.J. Visitainer, *Phys. Rev. Lett.* 23 (1969) 1421.
- [23] J.W. Doane, D.L. Johnson, *Chem. Phys. Lett.* 6 (1970) 291.
- [24] N. Bloembergen, E.M. Purcell, R.V. Pound, *Phys. Rev.* 73 (1948) 679.
- [25] R.K. Wangness, F. Bloch, *Phys. Rev.* 89 (1953) 728.
- [26] A. Abragam, *Principles of Nuclear Magnetism*, Clarendon Press, Oxford, 1961.
- [27] R.R. Vold, R.L. Vold, *J. Chem. Phys.* 88 (1988) 465.
- [28] R. Blinc, M. Luzar, M. Vilfan, M. Burgar, *J. Chem. Phys.* 63 (1975) 3445.
- [29] M. Vilfan, M. Kogoj, R. Blinc, *J. Chem. Phys.* 86 (1987) 1055.
- [30] H.C. Torrey, *Phys. Rev.* 92 (1953) 962.
- [31] V. Graf, F. Noack, M. Stohrer, *Z. Naturforsch.* 32a (1977) 61.
- [32] K.H. Schweikert, F. Noack, *Z. Naturforsch.* 44a (1989) 597.
- [33] S. Zumer, M. Vilfan, *Phys. Rev. A* 17 (1978) 424.
- [34] M. Vilfan, S. Zumer, *Phys. Rev. A* 21 (1980) 672.
- [35] R.Y. Dong, *Nuclear Magnetic Resonance of Liquid Crystals*, Springer, New York, 1997.
- [36] R. Kimmich, *Bull. Magn. Reson.* 1 (1980) 195.
- [37] G. Nagel, W. Wölfel, F. Noack, *Israel J. Chem.* 23 (1983) 380.
- [38] F. Noack, M. Notter, W. Weiss, *Liq. Cryst.* 3 (1988) 907.
- [39] E. Anardo, G.M. Ferrante, *Appl. Magn. Reson.* 24 (2003) 85.
- [40] G.O. Forte, G.D. Farrher, L.R. Canali, E. Anardo, *IEEE Trans. Control Syst. Technol.* 18 (2010) 976.
- [41] J. Perlo, E. Anardo, *J. Magn. Reson.* 181 (2006) 262.
- [42] E. Anardo, F. Bonetto, R. Kimmich, *Phys. Rev. E* 68 (2003) 022701.
- [43] H.S. Sellers, T. Margulies, W.H. Schwarz, *Mol. Cryst. Liq. Cryst.* 162B (1988) 185.

- [44] P.K. Khabibullaev, E.V. Gevorkyan, A.S. Lagunov, *Rheology of Liquid Crystals*, Allerton Press, New York, 1994.
- [45] H. Imura, K. Okano, *Chem. Phys. Lett.* 19 (1973) 387.
- [46] S. Nagai, P. Martinoty, S. Candau, *J. Phys.* 37 (1976) 769.
- [47] W. Helfrich, *Phys. Rev. Lett.* 29 (1972) 1583.
- [48] J.-L. Dion, *J. Appl. Phys.* 50 (1979) 2965.
- [49] F. Bonetto, E. Anardo, R. Kimmich, *Chem. Phys. Lett.* 361 (2002) 237.
- [50] J. Selinger, M. Spector, V. Greanya, B. Weslowsky, D. Shenoy, R. Shashidhar, *Phys. Rev. E* 66 (2002) 051708.
- [51] F. Bonetto, E. Anardo, R. Kimmich, *J. Chem. Phys.* 118 (2003) 9037.
- [52] F. Bonetto, E. Anardo, *Phys. Rev. E* 68 (2003) 021703.
- [53] F. Bonetto, E. Anardo, *J. Chem. Phys.* 121 (2004) 554.
- [54] J. Perlo, L. Aguirre, J. Revelli, E. Anardo, *Chem. Phys. Lett.* 450 (2007) 170.
- [55] P.C. Martin, O. Parodi, P.S. Pershan, *Phys. Rev. A* 6 (1972) 2401.
- [56] M.R. Fisch, L.B. Sorensen, P.S. Pershan, *Phys. Rev. Lett.* 47 (1981) 43.
- [57] A. Böttger, J.G.H. Joosten, *Europhys. Lett.* 4 (1987) 1297.
- [58] S. Sharma, K. Neupane, A. Adorjan, A.R. Baldwin, S. Sprunt, *Phys. Rev. Lett.* 94 (2005) 067801.
- [59] W. Helfrich, *Phys. Rev. Lett.* 21 (1968) 1518.
- [60] F. Lonberg, S. Fraden, A.J. Hurd, R. Meyer, *Phys. Rev. Lett.* 52 (1984) 1903.
- [61] W. Helfrich, *J. Chem. Phys.* 51 (1969) 4092.
- [62] U.D. Kini, *J. Phys. II France* 5 (1995) 1841.
- [63] P.E. Cladis, W. van Saarloos, P.L. Finn, A.R. Kortan, *Phys. Rev. Lett.* 58 (1987) 222.
- [64] E. Anardo, R. Kimmich, *Chem. Phys. Lett.* 440 (2007) 352.
- [65] J. Struppe, F. Noack, *Liq. Cryst.* 20 (1996) 595.
- [66] G. Tóth, C. Denniston, J.M. Yeomans, *Phys. Rev. Lett.* 88 (2002) 105504.
- [67] L.E. Aguirre, V. Pellegrini Mammana, E. Anardo, in: *Proceed. LatinDisplay 2009*, Sao Paulo, 2009, p. 184.