

Grover on SM3

Gyeongju Song¹, Kyungbae Jang¹, Hyunji Kim¹,
Wai-Kong Lee², Zhi Hu³, and Hwajeong Seo¹[0000-0003-0069-9061]

¹IT Department, Hansung University, Seoul (02876), South Korea,
{thdrudwn98, starj1023, khj1594012, hwajeong84}@gmail.com

²Department of Computer Engineering,
Gachon University, Seongnam, Incheon (13120), Korea,
waikonglee@gachon.ac.kr ³Central South University, China,
huzhi_math@csu.edu.cn

Abstract. Grover search algorithm accelerates the key search on the symmetric key cipher and the pre-image attack on the hash function. In order to perform Grover search algorithm, the target algorithm should be implemented in a quantum circuit. For this reason, we propose an optimal SM3 hash function (Chinese standard) in a quantum circuit. We focused on minimizing the use of qubits together with reducing the use of quantum gates. To do this, the on-the-fly approach is utilized for message expansion and compression functions. In particular, the previous value is restored and used without allocating new qubits in the permutation operation. Finally, we estimate quantum resources required for the quantum pre-image attack based on the proposed SM3 hash function implementation in the quantum circuit.

Keywords: Quantum Computer · Grover Algorithm · SM3 Hash Function.

1 Introduction

Quantum computers can solve specific problems in quantum algorithms much faster than classical computers. Two representative quantum algorithms that work on quantum computers are Shor's algorithm [1] and Grover's algorithm [2]. Shor's algorithm makes RSA (Rivest–Shamir–Adleman) and ECC (Elliptic Curve Cryptography), the most commonly used public key cryptography, vulnerable. Integer factorization and discrete logarithm problems used in RSA and ECC are hard problems in classical computers. However, quantum computers using Shor's algorithm solve these hard problems within a polynomial time. In order to prevent this attack, NIST (National Institute of Standards and Technology) is working on a standardizing post-quantum cryptography. In the standardization process, various post-quantum algorithms have been submitted. Grover's algorithm accelerates finding the specific data in databases (i.e. brute force attacks). If $O(n)$ queries were required in the brute force attack, it can be reduced to $O(\sqrt{n})$ queries by using Grover's algorithm. In cryptography, Grover's algorithm lowers the n -bit security level symmetric key cipher and hash function to $\frac{n}{2}$ -bit (i.e. half) for key search and pre-image attack.

In recent years, it is an active research field to optimize and implement symmetric key ciphers [3–13] and hash functions [14] as quantum circuits in order to minimize quantum resources required for Grover’s algorithm. In [15], quantum cryptanalysis benchmarking was performed by comparing resources required to attack public key cryptography, symmetric key cryptography, and hash function. In the quantum circuit optimization, it is important to reduce the number of qubits and quantum gates. Among them, the most important factor is to reduce the required qubits. As the number of qubits increases, quantum computers become more difficult to operate in a practical manner. International companies, such as IBM, Google, and Honeywell, are in the process of increasing the number of qubits for high computing quantum computers.

In this paper, we focused on minimizing qubits required to implement the SM3 hash function in a quantum circuit, while at the same time reducing the complexity of quantum gates. The existing message expansion function was divided into first extension and second extension. The compression function was divided into first compression and second compression, and then mixed and used. Through this method, the total number of qubits used was reduced by reusing the qubits used in the message. In the permutation operation, the value was returned through the CNOT-gate repetition rather than using a qubit to store the original value. As a result, we achieved an optimal quantum circuit of the SM3 hash function. In this paper, we used 2,176 qubits for storing the extended message (W_j ($j = 0, 1, \dots, 67$)), 32 qubits for the T constant to be used for the update, and 256 qubits for the register update and output of the final hash value. It also used 32 qubits for permutation operations, 1 qubit for ripple-carry addition, and 224 qubits for AND and OR operations.

1.1 Contribution

- **First implementation of the SM3 hash function in a quantum circuit** To the best of our knowledge, this is the first implementation of the SM3 hash function in a quantum circuit. We obtained the optimal quantum circuit by minimizing the use of qubits together with reducing the quantum gate complexity.
- **Efficient design of SM3 operations in a quantum circuit** We reduced the use of qubits by dividing expansion function and compression function of the original SM3 hash function and mixing them. Permutation operations were also performed with minimum qubits.
- **Quantum resource estimation of Grover search algorithm for the SM3 hash function** We evaluate quantum resources for the quantum pre-image attack to the SM3 hash function. The quantum programming tool, namely IBM ProjectQ [16], is used to evaluate the proposed quantum implementation of SM3 hash function.

2 Related Work

2.1 SM3 Hash Function

The hash function completely changes the output value with only small changes in the input value, thus ensuring the integrity by detecting errors in the message. The hash function efficiently generates the hashed value, allowing it to be digitally signed and verified, and to generate and verify messages. The SM3 hash function is operated in units of 32 words and finally outputs a hash value of 256 bits. After increasing the message length using padding, the message expansion calculation is performed by the following Equation 1 to expand the message to $W_0, W_1, \dots, W_{67}, W'_0, \dots, W'_{63}$.

$$\begin{aligned} W_j &\leftarrow P_j(W_{j-16} \oplus W_{j-9} \oplus (W_{i-3} \lll 15)) \oplus (W_{j-13} \lll 7) \oplus W_{j-6} \\ W'_j &= W_j \oplus W_{j+4}, \quad (16 \leq j \leq 67) \end{aligned} \quad (1)$$

The message expansion function expands the message block $B^{(i)}$ to 132 words ($W_0, W_1, \dots, W_{67}, W'_0, \dots, W'_{63}$). First, the existing message block $B^{(i)}$ is divided into 16 words W_0, W_1, \dots, W_{15} and expanded to W_{16}, \dots, W_{67} using this. The expanded message makes $W_0, W_1, \dots, W_{67}, W'_0, W'_1, \dots, W'_{63}$ through the Equation 1. The extended 132 word message is updated to registers (A, B, C, D, E, F, G, H) through the compression function. Registers (A, B, C, D, E, F, G, H) are 32 bits each, and initial values are stored. The final hash value is generated by performing the XOR operation to the updated register value with the previous register value through the compression function.

Algorithm 1 Compression function of the SM3 hash function.

Input: $W_0, W_1, \dots, W_{67}, W'_0, \dots, W'_{63}$.

Output: 32-qubits-register A, B, C, D, E, F, G, H after the message compression.

```

1: for  $j = 0$  to 63 do
2:    $SS1 \leftarrow ((A \lll 12) + E + (T_j \lll (j \bmod 32)) \lll 7)$ 
3:    $SS2 \leftarrow SS1 \oplus (A \lll 12)$ 
4:    $TT1 \leftarrow FF_j(A, B, C) + D + SS2 + W'_j$ 
5:    $TT2 \leftarrow GG_j(E, F, G) + H + SS1 + w_j$ 
6:    $D \leftarrow C$ 
7:    $C \leftarrow B \lll 9$ 
8:    $B \leftarrow A$ 
9:    $A \leftarrow TT1$ 
10:   $H \leftarrow G$ 
11:   $G \leftarrow F \lll 19$ 
12:   $F \leftarrow E$ 
13:   $E \leftarrow P_0(TT2)$ 
14: end for
15:  $V(i+1) \leftarrow ABCDEFGH \oplus V(i)$ 
16: return  $A, B, C, D, E, F, G, H$ 

```

The compression function proceeds to $V^{(i+1)} = CF(V^{(i)}, B^{(i)})$, $i = 0, \dots, n-1$ with the message of 132 words expanded in the message expansion function and previous 256-bit values as parameters. $SS1, SS2, TT1, TT2$ are intermediate variables of 32 bits, and T in the $SS1$ updates process contains the initial value of 32 bits. FF and GG function are Boolean functions that perform XOR, AND, and OR operations of parameters and output a value of 32 bits. FF and GG are used to update $TT1$ and $TT2$. The equation 2 is the calculation of FF and GG functions.

$$\begin{aligned}
 FF_j(X, Y, Z) &= X \oplus Y \oplus Z, \quad 0 \leq j \leq 15 \\
 FF_j(X, Y, Z) &= (X \wedge Y) \vee (X \wedge Y) \vee (Y \wedge Z), \quad 16 \leq j \leq 63 \\
 GG_j(X, Y, Z) &= X \oplus Y \oplus Z, \quad 0 \leq j \leq 15 \\
 GG_j(X, Y, Z) &= (X \wedge Y) \vee (\neg X \wedge Z), \quad 16 \leq j \leq 63
 \end{aligned} \tag{2}$$

In the compression function, the last register value is stored by updating the register by 64 times, and the final hash value of 256-bits is generated through an XOR operation with the register before the update.

2.2 Quantum Computing

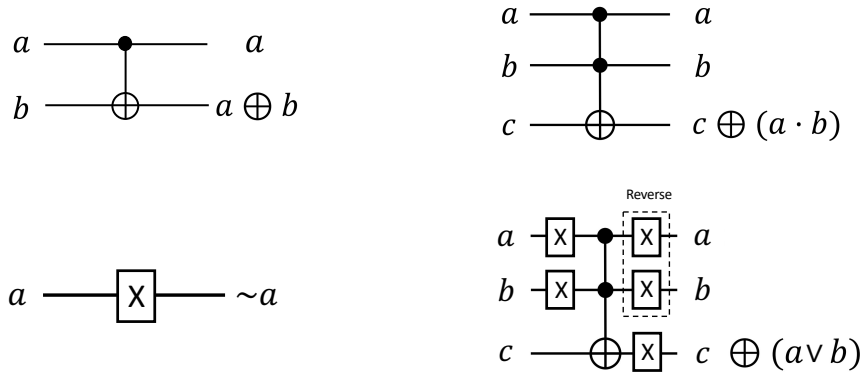

Fig. 1: CNOT gate, Toffoli gate, X gate, and OR gate in quantum gates.

Quantum computers utilize quantum mechanics phenomena, such as superposition and entanglement. The classical computer has bit, while the quantum computer has qubit that can superpose 0 and 1. In other words, the qubit has both values in the probability of being 0 and 1 and it is determined when it is measured.

As shown in Figure 1, quantum circuits also have quantum logic gates, such as digital logic gates in digital circuits. The quantum gate can control the state of the qubit. The X gate is a quantum logic gate that corresponds to the NOT

gate of a digital logic gate. The probability that the state of qubit becomes 0 is changed to the probability that it is determined as 1. The CNOT gate is a gate that represents an entangled state in which one qubit affects another qubit. It performs a NOT gate operation for the second qubit when the first qubit is 1. If the first qubit is 1, the NOT gate is applied to the second qubit. Otherwise, the second qubit is the output as it is. With the Toffoli gate, states of two qubits affect the state of one qubit. If the first two qubits among the three qubits are 1, a NOT operation is performed for the third qubit. Otherwise, the value of the third qubit is not changed.

In addition, there is a Hadamard gate, which puts qubits in a superposition state, and a SWAP gate, which changes the state of two qubits. The Toffoli gate is an expensive gate. X gate and CNOT gate are relatively inexpensive than the Toffoli gate. Since quantum computers with a large number of qubits are not currently developed, quantum circuits must be designed in the consideration of resources, such as qubits and quantum gates.

There are platforms for quantum computing, such as IBM's ProjectQ, Qiskit, or Microsoft's Q#. These platforms provide quantum gates, a variety of libraries, and simulators. Through the Qiskit platform, it is possible to use real quantum processors in the cloud platform. As such, quantum computing technologies are actively being developed, including the development of various quantum computing platforms and quantum languages.

2.3 Grover Search Algorithm

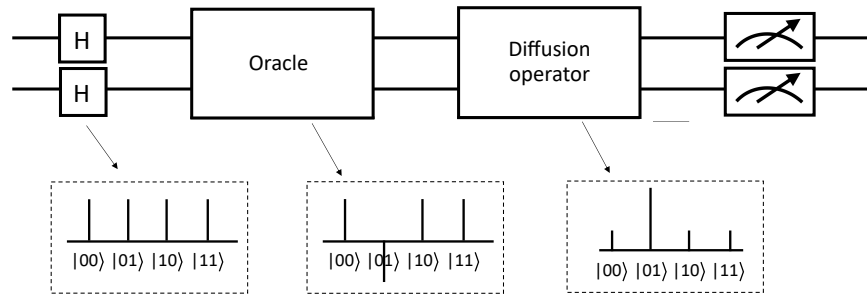

Fig. 2: Grover search algorithm (answer $x = 01$).

Grover search algorithm [2] is a quantum algorithm that searches a space with n elements to find the input data that generates the output of a particular function. On a classic computer, n searches are required to search an unsorted database. Since Grover search algorithm can find the answer by searching for the \sqrt{n} , the time complexity is reduced from $O(n)$ to $O(\sqrt{n})$. In other words, Grover algorithm threatens the symmetric key cryptography because it shortens the time required for brute force attacks.

Grover search algorithm consists of oracle and diffusion operators, and steps are as follows. First, Hadamard gates are applied to qubits. The oracle function $f(x)$ returns 1 when the x is the answer, and inverts the phase of qubits representing the answer. Then, the diffusion operator amplifies the amplitude of inverted qubits through the oracle, increasing the probability of becoming the answer. Through repeating the oracle and diffusion process, the probability of the answer is over the threshold. Finally, the value of x that exceeds the threshold becomes the answer. The overall structure of Grover search algorithm when the answer $x = 01$ is shown in Figure 2.

3 Proposed Method

3.1 SM3 Hash Function on Quantum Circuit

In the SM3 hash function designed in quantum circuits, we estimate the resource for applying Grover's algorithm based on the message padded with 512 bits. We propose a method of recycling message qubits by mixing the padded message with the message expansion function and the compression function. Two word messages ($W_j, W'_j (j = 0, 1, \dots, 63)$) are included to update the register once with the compression function. First, we proposed the method to update $W'_j (j = 0, 1, \dots, 63)$ to the $W_j (j = 0, 1, \dots, 63)$ message and save qubits through recycling. Second, it shows how to update and use existing assigned qubits instead of additional qubits for intermediate variables ($SS1, SS2, TT1$), and $TT2$ used by the existing SM3 hash function. Since the qubit cannot be reset, its own ongoing and ongoing permutation operations require a qubit assignment for each register update. To prevent this, we saved qubits by not allocating qubits and replacing the CNOT gates with repetitive tasks.

3.2 Message Expansion

The original SM3 hash function was proposed that outputs a hash function by expanding a message and then updating a register through a compression function. However, applying these methods to quantum circuits is inefficient, because 4,224 qubits are required only for the message expansion. To solve this problem, we store the padded 512-bit message B in W_0, W_1, \dots, W_{15} and update $W_{16}, W_{17}, \dots, W_{67}$ using permutation operations and CNOT gates. Updated values ($W_0, W_{17}, \dots, W_{67}$) are used for the first compression function and then recycled to update the $W'_0, W'_1, \dots, W'_{63}$ in the second compression function without allocating additional qubits. Therefore, the message expansion function and the compression function are divided into first message expansion function and second message expansion function, first compression function and second compression function, and used in combination. Figure 3 is the configuration of the proposed system.

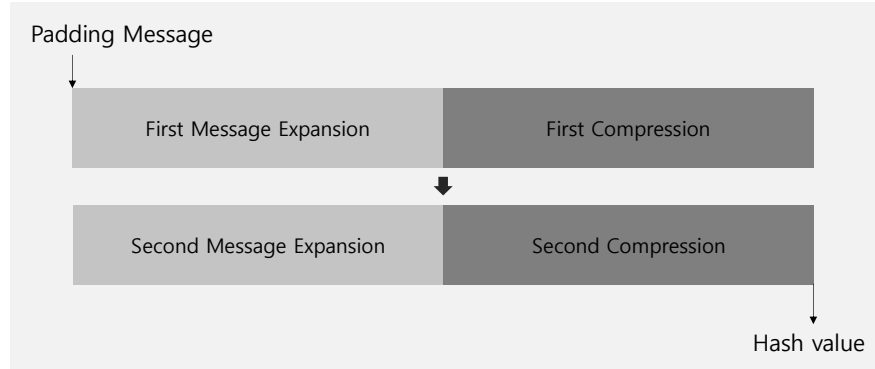

Fig. 3: System configuration for the proposed method.

Algorithm 2 First message expansion quantum circuit algorithm.

Input: W_0, W_1, \dots, W_{15} .

Output: $W_{16}, W_{17}, \dots, W_{67}$.

```

1: Update:
2:   for  $i = 0$  to 31 do
3:      $W_{j-16}[i] \leftarrow \text{CNOT}(W_{j-9}[i], W_{j-16}[i]), j = 16, \dots, 67$ 
4:      $W_{j-16}[i] \leftarrow \text{CNOT}(W_{j-3}[(i+15)\%32], W_{j-16}[i]), j = 16, \dots, 67$ 
5:   end for
6:    $\text{Permutation}_{P1}(W_{j-16})$ 
7:   for  $i = 0$  to 31 do
8:      $W_j[i] \leftarrow \text{CNOT}(W_{j-16}[i], W_j[i]), j = 16, \dots, 67$ 
9:      $W_j[i] \leftarrow \text{CNOT}(W_{j-13}[(i+15)\%32], W_j[i]), j = 16, \dots, 67$ 
10:     $W_j[i] \leftarrow \text{CNOT}(W_{j-6}[(i+15)\%32], W_j[i]), j = 16, \dots, 67$ 
11:  end for
12: Update(reverse)
13: return  $W_{16}, W_{17}, \dots, W_{67}$ 

```

Algorithm 2 is the first message expansion quantum circuit that updates $W_{16}, W_{17}, \dots, W_{67}$. In the first message expansion algorithm, W_j ($16 \leq j \leq 67$) is generated using $W_{(j-16)}, W_{(j-9)}, W_{(j-3)}, W_{(j-13)}, W_{(j-6)}$ ($16 \leq j \leq 67$). Since qubits cannot perform simple allocation operations, CNOT gate operation values in line 4 and 5 are stored in $W_{(j-16)}$. Since W_j is generated and the previous message value should not be changed. The update result value is stored in W_j , and the value of $W_{(j-16)}$ changed during the update process is reversed and returned. The Permutation_{P1} function in line 5 performs the Equation 4. Line 16 reverses lines 2 through 8. Figure 3 shows the progress of the proposed system. After the first expansion function, the first compression function proceeds. Then, second expansion function and second compression function are performed.

Algorithm 3 Second message expansion quantum circuit algorithm.

Input: $W_k, W_{k+4}, k = 0, \dots, 63$.

Output: $W'_t, t = 0, \dots, 63$.

```

1: for  $i = 0$  to 31 do
2:    $W'_{j[i]} \leftarrow \text{CNOT}(W_{j[i]}, W_{j+4[i]}), j = 0, \dots, 63$ 
3: end for
4: return  $W'_t, t = 0, \dots, 63$ 

```

In the second expansion function, the CNOT gate operation is performed on the message (W_0, \dots, W_{67}) used in the first compression function, and a new message (W'_0, \dots, W'_{63}) is output. In this way, the qubit was reused. The message (W'_0, \dots, W'_{63}) generated by the second expansion function is used by the second compression function.

3.3 Message Compression

The compression function uses an extended message to update the register. Both W_0, \dots, W_{63} and W'_0, \dots, W'_{63} are required to use the compression function. After using W_0, \dots, W_{63} , we reuse it as W'_0, \dots, W'_{63} to reduce the use of qubits. The first expansion function is executed and the obtained value (W_0, \dots, W_{63}) is to run the first compression function. Then, the second expansion function is to generate the value (W'_0, \dots, W'_{63}) and performs the second compression function. Algorithm 4 and Algorithm 5 are the first compression function and the second compression function, respectively.

Algorithm 4 First compression quantum circuit algorithm.

Input: 32-qubits-register $A, B, C, D, E, F, G, H, W_0, \dots, W_{63}$.

Output: 32-qubits-register A, B, C, D, E, F, G, H after the first compression.

```

1: Update:
2:  $T_j \leftarrow (T_j \lll j \bmod 32) \lll 7, j = 0, \dots, 63$ 
3:  $value0 \leftarrow GG$ 
4:  $value1 \leftarrow FF$ 
5:  $E \leftarrow SS1$ 
6:  $A \leftarrow SS2$ 
7:  $H \leftarrow TT2$ 
8: return  $A, B, C, D, E, F, G, H$ 

```

$$\begin{aligned}
SS1 &= ((A \lll 12) + E + T_j) \lll 7, j = 0, \dots, 63 \\
SS2 &= E \oplus (A \lll 12) \\
TT1 &= FF_j + D + A + W'_j \\
TT2 &= GG_j + H + SS1 + W_j
\end{aligned} \tag{3}$$

The first compression function given in Algorithm 4 calculates constants required for the register update. Using qubits as intermediate variables in quantum

circuits, it consumes a lot of resources. Therefore, the calculation was performed in the register where the final value will be stored. In the first compression function, qubits of each 32-bit intermediate constant ($SS1$, $SS2$, $TT1$, and $TT2$) were stored. Constants ($SS1$, $SS2$, $TT1$, and $TT2$) are calculated through the equation 3. In the first compression function, Boolean functions (GG and FF) are used to calculate the value. GG and FF are calculated as 2, and the final result is stored in the variables ($value0$, $value1$) and used for calculating $TT1$ and $TT2$.

The value of existing register E is not used after GG function and $SS1$ update. Therefore, the value of $SS1$ is calculated in the register E . Since the value of the existing register A is not used after the FF function, it is stored and used in the $SS2$ value register A . $TT2$ is updated with the extended message (W_0, \dots, W_{63}) and the $SS1$ value stored in the register E . At this time, the value of register H is not used after $TT2$ operation. $TT2$ value is stored in register H . As a result, the value of $TT2$ after the first compression function is stored in the register (H). Since the extended message (W_0, \dots, W_{63}) in the first message expansion function is not use after being used for the $TT2$ update in the first compression function. The first compression function is finished and the message (W'_0, \dots, W'_{63}) is updated to the message (W_0, \dots, W_{63}) through the second expansion function based on the expression equation 1. Finally, we use the updated message (W'_0, \dots, W'_{63}) to proceed with the second compression function.

$TT1$ updates with the extended message (W'_0, \dots, W'_{63} and $SS2$) stored in the register (A). We use the updated message (W'_0, \dots, W'_{63}) to proceed with the second compression function. $TT1$ updates with the extended message (W'_0, \dots, W'_{63}) and $SS2$ stored in the register (A). At this time, the value of register (D) is not used after the $TT1$ operation. The $TT1$ value is stored in the register (D). To update the register, original A and E register values are required. Therefore, lines 2 to 6 of the first compression function are reversed. Then, the register H is computed with the $permutation_{P1}$ operation and all registers are updated through the swap operation. The swap operation is an operation that only changes the bit position. For this reason, there is no additional resources.

3.4 Hash Value

After the first expansion function is used, the first compression function, second expansion function, and second compression function are repeated by 64 times in order. By completing the iteration, updated registers (A, B, C, D, E, F, G , and H) are XOR with previous registers (A, B, C, D, E, F, G , and H).

3.5 Permutation

In the SM3 hash function, there are two permutation functions (P_0 and P_1). The Equation 4 is the expression of P_0 , P_1 .

$$\begin{aligned} P_0(X) &= X \oplus (X \lll 9) \oplus (X \lll 17) \\ P_1(X) &= X \oplus (X \lll 15) \oplus (X \lll 23) \end{aligned} \quad (4)$$

Algorithm 5 Second compression quantum circuit algorithm.

Input: 32-qubits-register	$A, B, C, D,$	
	$E, F, G, H, W'_0, \dots, W'_{63}.$	5: $B \leftarrow B \lll 9$
Output: 32-qubits-register	$A, B, C, D,$	6: $F \leftarrow F \lll 19$
	E, F, G, H after the second compression.	7: $Swap(A, H)$
1: $D \leftarrow TT1$		8: $Swap(B, H)$
		9: $Swap(C, H)$
2: Update of first compression (reverse)		10: $Swap(D, H)$
		11: $Swap(E, H)$
3: $H \leftarrow Permutation_{p0}$		12: $Swap(F, H)$
		13: $Swap(G, H)$
4: $Swap(D, H)$		14: return A, B, C, D, E, F, G, H

Algorithm 6 Part of the P_0 calculation.

Input: $a_{16}.$		4: $a_{16} \leftarrow CNOT(a_{14}, a_{16})$
Output: $a_{16} \leftarrow a_{16} \oplus a_7 \oplus a_{31}.$		5: $a_{16} \leftarrow CNOT(a_{13}, a_{16})$
1: $a_{16} \leftarrow CNOT(a_7, a_{16})$		6: $a_{16} \leftarrow CNOT(a_5, a_{16})$
2: $a_{16} \leftarrow CNOT(a_{31}, a_{16})$		
3: $a_{16} \leftarrow CNOT(a_{22}, a_{16})$		7: return $a_{16} \leftarrow a_{16} \oplus a_7 \oplus a_{31}$

P_0 and P_1 permutation operations shift themselves and use the CNOT gate. If the operation value is saved, it is difficult to find the original qubit value, causing problems in subsequent operations. In normal cases, original values of qubits should be stored and used qubits are used. In the P_1 operation, a qubit is to store the value before the operation is allocated. And then, it can be used again in the next operation through the reverse operation. Therefore, a 32-bit storage qubit is allocated and used. In the P_0 operation, the stored qubit cannot be reused by the reverse operation. There is a problem that 32 qubits must be allocated every time and the compression function update should be repeated. To solve this problem, we used that if the same bit is counted twice as the CNOT gate, the counting is canceled. As a result, in P_0 , the permutation operation was performed through the repeated use of the CNOT gate without allocating a qubit. The P_0, P_1 is used in the compression function. Algorithm 6 represents a part of this operation and Table 1 represents the state that changes as the operation progresses.

When $A = a_{31}, \dots, a_0$ is given and a_0 is the most significant bit, the CNOT gate is executed in the order of a_{31}, \dots, a_{17} . It is difficult to find the original a_{31} required in the calculation of a_{16} . Therefore, the operation to find the existing value was performed by repeatedly using the CNOT gate. The Algorithm 6

Table 1: Changes of states during Algorithm 6.

Line	Qubit	State
1	a_{16}	$a_{16} \oplus a_7$
2	a_{16}	$a_{16} \oplus a_7 \oplus a_{31} \oplus a_{22} \oplus a_{14}$
3	a_{16}	$a_{16} \oplus a_7 \oplus a_{31} \oplus a_{14} \oplus a_{13} \oplus a_5$
4	a_{16}	$a_{16} \oplus a_7 \oplus a_{31} \oplus a_{13} \oplus a_5$
5	a_{16}	$a_{16} \oplus a_7 \oplus a_{31} \oplus a_5$
6	a_{16}	$a_{16} \oplus a_7 \oplus a_{31}$

computes a_{16} as part of $P0$. At this time, the CNOT gate was repeatedly used to use the original a_{31} , and the state change for each use is shown in the Table 1. Since XOR operation values of a_{16} , a_7 , a_{31} should be stored in a_{16} , they are calculated in order. Since the calculation was performed from a_{31} , the values of a_{16} and a_7 are preserved. In line 1, XOR values of a_{16} and a_7 are stored in a_{16} . In line 2, the value of a_{31} is executed with the XOR operation. At this time, XOR values of a_{31} , a_{22} , and a_{14} are stored in a_{31} . Since a_{22} and a_{14} are unnecessary values, we use the CNOT gate once more to cancel them. In line 4, the CNOT gate to a_{14} to neutralize the value. In line 3, the CNOT gate was used to neutralize the a_{22} value. Since XOR operation values of a_{22} , a_{13} , and a_5 were stored in a_{22} , only a_{22} value was obtained by performing a_{13} , a_5 and the CNOT gate in lines 5 and 6.

4 Evaluation

The proposed SM3 quantum circuit implementation is evaluated with the quantum emulator, namely IBM ProjectQ. Among various compilers provided by IBM ProjectQ, quantum compilers can estimate resources of implemented quantum circuits. It measures the number of Toffoli gates, CNOT gates, X gates, and qubits used in a quantum circuit.

We focused on optimizing the quantum gates and qubits for the implementation of the SM3 quantum circuit. One of important elements of a quantum circuit is making it work with minimal resources. Currently, the number of qubits available in quantum computer technology is limited, and it is efficient to reduce the cost of the quantum gate. Therefore, it can be used as an index to confirm the efficiency of the quantum circuit by comparing the quantum circuit resources of the SM3 quantum circuit proposed in this paper with other hash functions. Table 2 shows the amount of quantum resources used in the proposed SM3 quantum circuit. It also shows quantum resources including hash functions (SHA2 and SHA3) [14] as specified by the US national standard. SHA-256 and proposed SM3 are evaluated based on 512-bit message block input, and SHA3-256 has the same resources at all input lengths with a sponge structure.

First, in the proposed SM3 quantum circuits, qubits to be used for the message storage were reduced by mixing the expansion function and the compression function. By dividing the expansion function and the compression function into

Table 2: Quantum resources required for SHA2 and SHA3 quantum circuits and the proposed SM3 quantum circuit.

Algorithm	Qubits	Toffoli gates	CNOT gates	X gates
SHA2 [14]	2,402	57,184	534,272	–
SHA3 [14]	3,200	84,480	33,269,760	85
Proposed SM3	2,721	43,328	134,144	2,638

two, message qubits used in the first compression function can be reused in the second compression function.

Second, in the permutation operation, we found the original value with the CNOT gate without allocating a bit to store the original value. In this way, we reduced the number of qubits.

Finally, fewer qubits, Toffoli gates, and CNOT gates are used compared to SHA2 and SHA3. Based on this optimal quantum circuit, we can minimize quantum resources required for Grover’s search algorithm for the SM3 hash function.

5 Conclusion

In this paper, we implemented and optimized the SM3 hash function as a quantum circuit, and estimated required quantum resources. Quantum resources required for a quantum pre-image attack using Grover search algorithm are determined according to the quantum circuit of the target hash function. Utilizing proposed SM3 quantum circuits, Grover search algorithm can be efficiently applied, and its performance is confirmed by comparing it with quantum resources with other researches. It is expected that the proposed implementation of the SM3 hash function in quantum circuits can be effectively applied to Grover search algorithm.

References

1. P. W. Shor, “Polynomial-time algorithms for prime factorization and discrete logarithms on a quantum computer,” *SIAM J. Comput.*, vol. 26, p. 1484–1509, Oct. 1997.
2. L. K. Grover, “A fast quantum mechanical algorithm for database search,” in *Proceedings of the twenty-eighth annual ACM symposium on Theory of computing*, pp. 212–219, 1996.
3. M. Grassl, B. Langenberg, M. Roetteler, and R. Steinwandt, “Applying Grover’s algorithm to AES: quantum resource estimates,” in *Post-Quantum Cryptography*, pp. 29–43, Springer, 2016.
4. B. Langenberg, H. Pham, and R. Steinwandt, “Reducing the cost of implementing AES as a quantum circuit,” tech. rep., Cryptology ePrint Archive, Report 2019/854, 2019.

5. S. Jaques, M. Naehrig, M. Roetteler, and F. Virdia, “Implementing Grover oracles for quantum key search on AES and LowMC,” in *Annual International Conference on the Theory and Applications of Cryptographic Techniques*, pp. 280–310, Springer, 2020.
6. R. Anand, A. Maitra, and S. Mukhopadhyay, “Grover on SIMON,” *Quantum Information Processing*, vol. 19, no. 9, pp. 1–17, 2020.
7. K. Jang, S. Choi, H. Kwon, and H. Seo, “Grover on SPECK: Quantum resource estimates.” Cryptology ePrint Archive, Report 2020/640, 2020. <https://eprint.iacr.org/2020/640>.
8. K. Jang, H. Kim, S. Eum, and H. Seo, “Grover on GIFT.” Cryptology ePrint Archive, Report 2020/1405, 2020. <https://eprint.iacr.org/2020/1405>.
9. L. Schlieper, “In-place implementation of quantum-Gimli,” *arXiv preprint arXiv:2007.06319*, 2020.
10. K. Jang, S. Choi, H. Kwon, H. Kim, J. Park, and H. Seo, “Grover on Korean block ciphers,” *Applied Sciences*, vol. 10, no. 18, p. 6407, 2020.
11. K. Jang, G. Song, H. Kim, H. Kwon, H. Kim, and H. Seo, “Efficient implementation of PRESENT and GIFT on quantum computers,” *Applied Sciences*, vol. 11, no. 11, p. 4776, 2021.
12. G. Song, K. Jang, H. Kim, W.-K. Lee, and H. Seo, “Grover on Caesar and Vigenère ciphers,” *IACR Cryptol. ePrint Arch.*, vol. 2021, p. 554, 2021.
13. K. Jang, G. Song, H. Kwon, S. Uhm, H. Kim, W.-K. Lee, and H. Seo, “Grover on PIPO,” *Electronics*, vol. 10, no. 10, p. 1194, 2021.
14. M. Amy, O. D. Matteo, V. Gheorghiu, M. Mosca, A. Parent, and J. Schanck, “Estimating the cost of generic quantum pre-image attacks on SHA-2 and SHA-3,” 2016.
15. V. Gheorghiu and M. Mosca, “Benchmarking the quantum cryptanalysis of symmetric, public-key and hash-based cryptographic schemes,” 2019.
16. D. S. Steiger, T. Häner, and M. Troyer, “ProjectQ: an open source software framework for quantum computing,” *Quantum*, vol. 2, p. 49, 2018.