

Summer 2023

Exploring Factors Associated with Academic Motivation and College and Career Readiness of Rural Adolescents

Peter N. Knox

University of Vermont, peter.knox@uvm.edu

Follow this and additional works at: <https://scholarsjunction.msstate.edu/ruraleducator>



Part of the [Other Education Commons](#)

Recommended Citation

Knox, P. N. (2023). Exploring Factors Associated with Academic Motivation and College and Career Readiness of Rural Adolescents. *The Rural Educator*, 44(3), 34-52. <https://doi.org/10.55533/2643-9662.1370>

This Research Article is brought to you for free and open access by Scholars Junction. It has been accepted for inclusion in The Rural Educator by an authorized editor of Scholars Junction. For more information, please contact scholcomm@msstate.libanswers.com.

Exploring Factors Associated with Academic Motivation and College and Career Readiness of Rural Adolescents

Cover Page Footnote

The author would like to offer sincere gratitude to Drs. Amber Simpson and Kimberly Brimhall. Thank you for your mentorship and guidance on this and subsequent projects. This work would not have been possible without your support. Thank you to Dr. Dawn Anderson-Butcher and the Community and Youth Collaborative Institute at The Ohio State University for providing access to this valuable data. Finally, thank you to educators and school leaders in rural contexts for your dedication and ingenuity in support of the postsecondary preparation and success of your students.

Exploring Factors Associated with Academic Motivation and College and Career Readiness of Rural Adolescents

Peter N. Knox

Past decades have seen an increase in focus on college and career readiness (CCR) policy and programming to meet the growing demand for a high-skill, global, 21st-century workforce. Recent research indicates many adolescents aspire to succeed in various postsecondary paths, but a persistent gap between aspirations and attainment remains. This is particularly true for traditionally underserved and underrepresented populations, such as those from rural communities. Looking beyond academic metrics such as test scores, grade point averages, and course offerings, this study seeks to address this gap by investigating rural adolescent school context and experience factors that may be associated with their academic motivation and CCR. A cross-sectional multivariate multiple linear regression analysis examining CCR and postsecondary choice factors was conducted using Mplus 8. Results from a large sample (N = 8,541) of rural adolescents from the Midwest United States found several variables—internalized and externalized behavior, peer relationships, parental involvement and support, and family/community connection—are positively associated with increasing favorable perceptions of academic motivation and college and career readiness. Study implications and directions for future research are offered.

As economic priorities shift and industries that historically supported diverse rural economies evolve or disappear, so do many opportunities for rural adolescents to remain and live similarly to previous generations (Tieken, 2014). Yet, changing cultural norms, community understanding, postsecondary education value, and alternative career/vocational options is a slow process and often remains tied to the past. Within-group cultural messages or norms may shape rural adolescent perspectives and motivation for future options or postsecondary trajectories (Agger et al., 2018; Gibbons et al., 2020). Despite such cultural components, recent trends indicate positive academic gauges such as increases in rural student graduation rates measuring above the national average (Showalter et al., 2017). These trends may indicate a shifting of mentality or value in postsecondary options alternative to local industry. However, other indicators such as lower postsecondary enrollment rates, delays in beginning higher education or vocational training programs, and postsecondary program completion rates for rural students still lag behind non-rural counterparts (Byun et al., 2015; Koricich et al., 2018). The persistent imbalance between rural and non-rural postsecondary outcomes requires investigation into other factors that may shape rural adolescent postsecondary self-efficacy (i.e., perceptions of ability to succeed), motivation, and preparation for life beyond secondary school.

Considering this in their 2016-2021 research agenda, the National Rural Education Association (NREA) made college and career readiness and postsecondary preparation one of their top ten

research priorities (Hill & Turney, 2016). Despite increased state and federal attention and inclusion in research agendas and reform efforts, continued disparities in rural postsecondary attainment demonstrate the need for continued investigation. Self-efficacy, defined as the perception of one's ability to perform certain tasks or behaviors (Bandura, 1986), and motivation are essential elements in adolescent college and career readiness (Conley, 2012). Yet it remains unclear what elements significantly influence rural adolescents' perceptions of their self-efficacy, motivation, and readiness for postsecondary options and how they influence choices and trajectories (Usher et al., 2019). Exploring the personal (i.e., social and emotional factors) and contextual (i.e., relationships, connections) elements that may influence rural adolescent perceptions, postsecondary motivation, and choices represent an entry point for addressing this disparity between rural and non-rural postsecondary outcomes.

Understanding how school experiences shape rural adolescent academic motivation and college and career readiness is vital to efforts in support of postsecondary education or career success and forms the foundation of this research. Social cognitive career theory (SCCT; Lent et al., 1994) suggests that personal factors (e.g., mental and physical health, race, gender) and contextual determinants (e.g., social connections, learning or training opportunities) combine to impact an individual's educational or career interests, choices, and performance. Concurrently, expectancy value theory (Eccles et al., 1983) argues that individual perceptions, self-

efficacy, as well as cultural and historical factors, shape an individual's values, expectations, and subsequent decision-making. Framed by these theories, this study aims to investigate various personal and contextual (Lent et al., 1994; Sheu & Borden, 2017) school experience factors that contribute to the perceptions of academic motivation and college and career readiness of a large sample of rural adolescents from the Midwest United States. Results demonstrate how five factors - internalized and externalized behavior, peer relationships, parental involvement and support, and family/community connection - are positively associated with increasing favorable perceptions of academic motivation and college and career readiness. This exploration of personal and contextual influences on constructs integral to rural adolescent success lends support to the development of targeted school policies and programs aimed at enhancing rural adolescent self-efficacy, motivation, and readiness. Through expanding understanding of structural and interpersonal factors, this study also contributes to school climate and culture literature and efforts to positively impact rural adolescent entrance, success, and completion of postsecondary pathways.

Relevant Literature

Elements that shape rural adolescent perceptions of self-efficacy, motivation, and readiness for postsecondary options and how those perceptions influence choices and trajectories remain understudied. Yet subsets of previous educational research offer insight into various components that may work in tandem to influence rural adolescent postsecondary outcomes. Thus, I situate the current study within three bodies of existing scholarship. The first is focused on rural education and the unique barriers and affordances faced by adolescents and their school experiences in their communities. The second focuses on adolescent college and career readiness and how it is influenced by individual and contextual elements including internalized and externalized behaviors, peer relationships, parental engagement and support, and family/community connections. Lastly, I discuss previous research centered around adolescent academic motivation--critical to college and career readiness--and how it is also influenced by the individual and contextual elements noted above. Collectively, scholarship focused on rural education, college and career readiness, and academic motivation guide the current study's specific investigation into the association between SCCT-related variables and rural adolescent

perceptions of their college and career readiness and academic motivation.

Rural Education

Previous research has found that despite increasing numbers of rural adolescents who aspire to various postsecondary options, such as higher education (Meece et al., 2014), the number of eligible rural adolescents that enroll in and complete higher education programs remains below the rate of urban or suburban peers (Byun et al., 2015; Koricich et al., 2018;). Several community characteristics and factors have been identified as barriers or challenges to rural adolescent career development and postsecondary attainment. Stemming from historical and cultural changes common to rural areas, elements such as lower socioeconomic status (SES), lower parental expectations or educational values, and limited preparation options in rural areas have all been found to influence postsecondary attainment (Byun et al., 2012a; Roscigno et al., 2006). Poverty remains a persistent and pervasive barrier that impacts rural adolescents and schools, with rates of child poverty and deep familial poverty (i.e., family income falls below half the poverty line) nearly 20% higher in rural communities relative to the national average (Schaefer et al., 2016). Poverty and familial SES play a role in parental expectations and value for postsecondary trajectories, as well, with higher-income adults and families often obtaining higher vocational and degree levels (Chenoweth & Galliher, 2004).

Research by Demi and colleagues (2010) further supports the strong ecological influence that parental perspectives can have on adolescent identification with postsecondary choices and trajectories. The strength of this influence or bond was found to impact the transmission of values of postsecondary education and the expectations of adolescents to attend a higher education program (Davis-Keane, 2005; Howley, 2006; Melby et al., 2008). These elements also impact the extent and quality of educational opportunities presented to rural adolescents. Rural schools typically have fewer advanced placement (AP) and specialized curriculum courses (e.g., International Baccalaureate) available to support adolescents in pursuit of advanced education (Anderson & Chang, 2011; Provasnik et al., 2007). Further, rural schools often have limited resources and experience challenges in recruiting and retaining high-quality educators to provide diverse and advanced instruction or other learning opportunities (Hardré, 2012; Kryst et al., 2018). In addition, many rural schools cannot emphasize postsecondary readiness because of limited resources and

challenges in providing advanced curricula (Ardoin, 2017) and are also limited in their ability to offer access to vocational development or apprenticeship programs (Gray, 2009).

Despite these broad social and contextual constraints faced by rural adolescents and families, certain characteristics and elements of rurality have been identified as affordances and supportive of adolescent postsecondary aspiration. Greater connection, social support, and longer-term relationships with teachers and supportive adults have all been identified as features of rural schooling that benefit student success (Hardré, 2012; Tiekens, 2014). Nelson (2016) identified overlapping features and attributes of family, school, and community social capital within rural communities that translate into educational attainment for rural adolescents. For example, the interwoven networks common within rural communities led to enhanced parent-school connections, as well as more extensive engagement by community members in out-of-school activities and support for rural adolescents (Nelson, 2016). Research by Griffin and colleagues (2011) suggests that various groups of rural students seek out and capitalize on different social connections and resources, depending upon their background and personal characteristics. Yet, this previous research also notes the paths and strength of influence that various elements of rural social capital take and the way they come to shape educational trajectories and postsecondary readiness of diverse rural adolescents remain less understood (Dika & Singh, 2002; Griffin et al., 2011).

Adolescents from rural communities face certain barriers to their preparation for various postsecondary pathways they might pursue. Concurrently, rural culture and community may provide certain affordances that lend support to adolescents' perspectives on postsecondary options and their self-efficacy toward achieving their goals. Yet, there remains a gap in the research regarding what experiential factors might most significantly impact rural adolescents and affect their perspective on their readiness for college or career, as well as the academic motivation necessary to achieve college or career aspirations (Usher et al., 2019). This study aims to address this gap by investigating the personal (i.e., social and emotional factors) and contextual (i.e., relationships, connections) factors that may influence both rural adolescent postsecondary readiness and academic motivation.

College and Career Readiness

As noted by Lent and Brown (2013), the development of both career and educational goals and

aspirations are dependent upon adolescent experiences and adaptive behaviors. These experiences and behaviors subsequently impact self-efficacy, expectations, and perceived value of a task or goal. As the concept of college and career preparation has risen in prominence within education policy and research circles, so have the number of definitions, metrics, and conceptualizations of what college and career readiness mean (Camara, 2013; Mishkind, 2014). In this study, I adopt the definition and parameters outlined by Conley (2012), who posited that students were prepared for postsecondary paths if they "...can qualify for and succeed in entry-level, credit-bearing courses leading to a baccalaureate or certificate, or career pathway-oriented training program without the need for remedial or developmental coursework," (p. 1). Said differently, this definition of college and career readiness means that regardless of whether a student chooses higher education or a career pathway, once that path is selected they will not require additional coursework post-graduation to "catch them up" to their peers or colleagues – they will already have the foundational knowledge required. Conley (2012) outlined several constructs that contribute to readiness for postsecondary trajectories including key content knowledge, key cognitive strategies, key learning skills and techniques, and key transition knowledge and skills. The relative importance of each of these constructs to postsecondary success is dependent upon the nature of one's aspirations or postsecondary goals, belief in their ability to succeed (i.e., self-efficacy), and motivation to persist and overcome barriers (Conley & French, 2014).

As attention to adolescent postsecondary preparation has increased, so too has scholarship focused on what might support or hinder adolescent readiness for various trajectories. Previous research has identified mental and behavioral health, understood as internalized and externalized behaviors, as critical components of adolescent postsecondary preparation (Bandura et al., 2001; Durlak et al., 2011; Sancassiani et al., 2015; Taylor et al., 2017). The interpersonal skills and individual qualities that support the development and maintenance of effective relationships have become highly valued in postsecondary education programs and across career fields (Johnson & Wiener, 2017; Schanzenbach et al., 2016). These interpersonal skills and abilities are impacted by adolescents' internalized and externalized behaviors and overall social-emotional state as they learn and grow (Johnson & Wiener, 2017; Moore et al., 2015).

An extensive body of research also highlights the increased importance of peer relationships and connections during adolescence (Jimerson et al.,

2012; Kutsyuruba et al., 2015; Thapa et al., 2013; Wentzel, 2017). Connections with friends, peers, significant others, and adolescents of similar age and experiences are influential factors in an adolescent's social and emotional well-being and decision-making processes (Wentzel, 2017). Previous literature has also noted that adolescent integration into peer groups and connections are highly impacted by adolescent self-concept and perception, which is itself correlated with close relationships and interpersonal experiences, including those with parents or caregivers (Cooper & Cooper Jr., 2016; Deković, & Meeus, 1997; Ladd & Kochenderfer-Ladd, 2019). Parental influence and involvement are also significant factors in adolescent decision-making, particularly around college or career trajectories (Ahn et al., 2022). Further, the circumstances and experiences of parents or caregivers impact their perspectives on various postsecondary pathways (Tate et al., 2015). These parental perspectives can explicitly or inadvertently be transferred to children, subsequently influencing goals and decision-making (McCarron & Inkelas, 2006; Tate et al., 2015). The concept of social capital for college or career also extends into an adolescent's broader environment or community. The resources, training, mentorship opportunities, and out-of-school connections or experiences afforded to adolescents can impact their perspective toward certain careers or educational paths (Lerner & Deeds, 2018; Thurman & Traill, 2021). Thus, lower-income, often isolated, and under-resourced rural communities may be limited in their ability to provide social capital and subsequent information, navigation skills, and resources to succeed in postsecondary contexts (Crawley et al., 2019). This influence (or not) on adolescents' perspectives can further impact awareness of various postsecondary options, aspirations, and goals of adolescents to pursue the necessary steps and tasks required to achieve their career or educational interests (Fan et al., 2012).

Academic Motivation

Conley and French (2014) described academic motivation as an essential starting point that sets adolescents on a path toward setting distinct goals, believing in their abilities, making choices to meet goals, and persisting over time and through challenges. Student motivation has been found to particularly influence engagement with learning and the purposeful establishment of goals and aspirations for a career or further education (Gaertner & McClarty, 2015; Richardson et al., 2012). Trowler (2010) elaborated on the concept of engagement, noting three primary categories - behavioral,

emotional, and cognitive – each of which impacts goals, self-efficacy, and self-regulation toward learning (Duncan et al., 2017; Fredricks et al., 2004; Gueldner et al., 2020). Further, each of these categories of engagement is directly impacted by student internal motivations and behaviors (i.e., enjoyment of learning, expectations for future career) and extrinsic motivations (i.e., learning for a specific gain like postsecondary entrance) (Fredricks et al., 2019; Richardson et al., 2012). Collectively, a student's academic motivations inform the strength and nature (positive or negative) of their engagement in learning and development opportunities, subsequently impacting goal orientation such as higher education or specific career and vocational training (Conley & French, 2014).

Recent research by Pascoe and colleagues (2020) suggests that academic motivation is impacted by a variety of factors, including internalized and externalized behaviors. Internalized behavior includes feelings and emotions such as stress, anxiety, depression, and burnout which have been associated with significant decreases in adolescent academic motivation, as well as increased rates of drop-out (Liu, 2015; Pascoe et al., 2020; Walburg, 2014). Adolescent levels of academic motivation have also been associated with the presence of both adaptive (e.g., planning, persistence, learning focus) and maladaptive behaviors (e.g., failure avoidance, disengagement) (Bugler et al., 2015; 2016). Closely linked to internalized behaviors (Skinner et al., 2008), an association between adolescent externalized behaviors (e.g., bullying, being bullied, cheating, absenteeism) and motivational orientation has also been identified (Bugler et al., 2016). Previous research investigating adolescent academic motivation has frequently included externalized student behaviors and their association with shifts in goal setting (e.g., content mastery vs. basic performance) (Martin, 2010; Shim et al., 2008). Investigating the association between motivation and achievement in the context of postsecondary choices, Martin (2010) argued that motivation and both behavioral intention and enactment hold close and reciprocal relationships. Expectancy value theory also suggests that the cost or negative value one perceives in a task or goal influences behavioral decisions which, in turn, impact adolescent motivation and subsequent choices (Eccles et al., 1983; Jiang et al., 2018). Yet, diverse school experiences and circumstances, as well as individual student characteristics may interact with both internalized and externalized behaviors of adolescents and their subsequent impact on academic motivation (Bugler et al., 2016). This requires more focused investigation into distinct populations and

demographic groups, such as rural adolescents, to better understand how these constructs may impact their motivation, goal setting, and postsecondary attainment.

Like adolescent college and career readiness, academic motivation may be influenced by the networks, connections, and relationships present in their lives. Kindermann (2016) suggested that motivation manifests as either engagement or disaffection, which is then externally presented to peers, educators, and family. Further research suggests that adolescent motivation is malleable and simultaneously impacted by both social and emotional factors (as those noted above) and connections to various individuals in their lives (Wentzel, 2017; Wigfield et al., 2019). Molloy et al. (2011) examined the influence that peer relationships may have on students' academic self-concept and effort, which are critical components of motivation. Their study found that the socialization processes experienced by middle school students significantly impacted adolescent achievement motivation and engagement and that this peer influence increased as students aged (Molloy et al., 2011). Looking beyond near-peer relationships, research by Fan and colleagues (2012) examined parental involvement and engagement and its impact on adolescent motivation. Results of their study indicated certain aspects of parental involvement such as parental aspirations for their children and communication of these aspirations positively impacted student motivation (Fan et al., 2012). This study also found that parental involvement and communication with educators regarding their adolescent's behavior or academic performance were negatively associated with student academic motivation (Fan et al., 2012). This supports previous research suggesting a differentiation in the impact that varying parental support or involvement has on the motivation, goal setting, and attainment of adolescents (Perna & Titus, 2005).

The concept of academic motivation becomes particularly important to investigate for marginalized populations and groups in which gaps between aspiration and achievement persist. As noted by Conley and French (2014), academic motivation and student self-efficacy or belief in their ability to perform a task or overcome a challenge are linked. Therefore, adolescent goals, actions, and motivation to pursue college or career aspirations are impacted by their awareness of and belief in their ability to succeed and their perceptions of readiness. For students coming from backgrounds or contexts in which postsecondary education or career development have been less prevalent, such as rural

communities, student motivation or belief in the value of their learning and postsecondary success may be dampened (Prins & Kassab, 2017; Roberts & Grant, 2021). Therefore, understanding influences on student motivation and what may be impacting their ownership of learning and goal setting provides insight into ways of addressing the gaps between aspiration and attainment that persist to this day.

The Current Study

The review of the literature above sheds light on potential barriers and supports for rural adolescent education and postsecondary aspirations. Further, this review noted research findings that highlight several factors that may influence readiness and motivation, such as internalized and externalized behavior, peer relationships, parental involvement, and broader community connections and experiences. While previous scholarship suggests that these constructs influence postsecondary preparation and motivation, what remains unclear is which of these may be most influential, particularly amongst under-researched and more vulnerable populations such as rural adolescents. To address this gap, the current study focused specifically on rural adolescent perceptions of both contextual and noncognitive variables, and their subsequent impact on perceptions of academic motivation and college/career readiness. In this study, student age, race, gender, socioeconomic status, and family arrangement (i.e., adult(s) participants live with) were used as control variables, as previous research indicates that these influence the experiences and interactions adolescents have with their school and learning (Bottiani et al., 2016; Henry et al., 2011; Youngblade et al., 2007). Thus, independent variables including internalized behavior, externalized behavior, peer relationships, parental involvement and support, and family/community connections were examined. Figure 1 demonstrates these relationships of interest.

Overall, this study aimed to provide greater insight into influences on rural adolescent postsecondary success and attainment. In particular, the current analysis seeks to determine which personal and contextual school experience factors might hold the most significant influence. Thus, informed by theory and previous research, this study presents an investigation of the following research hypotheses:

Hypothesis 1: Rural adolescent internalized behavior and externalized behavior will be positively associated with their perception of academic motivation and college and career readiness.

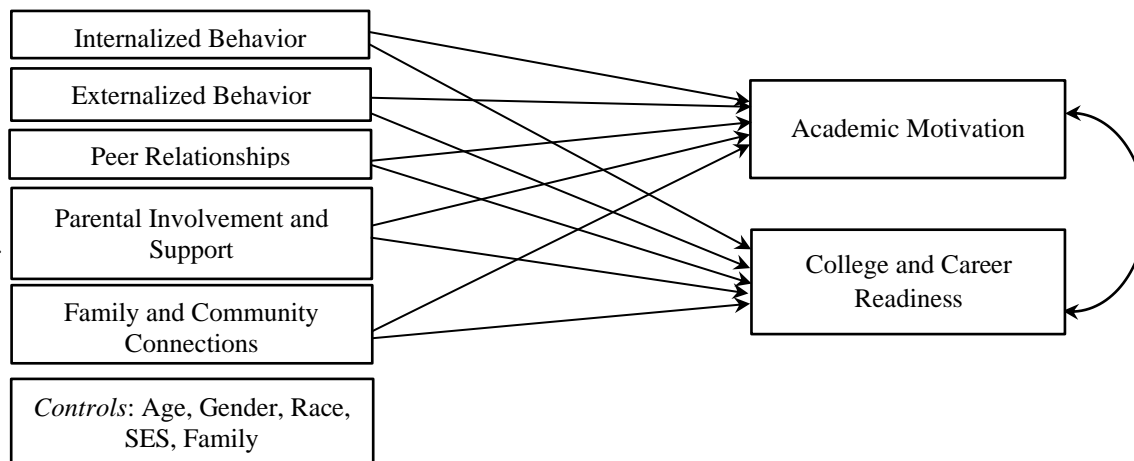

Figure 1. Multivariate multiple linear regression model demonstrating hypothesized associations between rural adolescent school experience variables and academic motivation and college and career readiness. *Note.* SES = socioeconomic status

Hypothesis 2: Rural adolescent peer relationships will be positively associated with adolescent perception of academic motivation and college and career readiness.

Hypothesis 3: Rural adolescent parental involvement and support will be positively associated with adolescent perception of academic motivation and college and career readiness.

Hypothesis 4: Rural adolescent family and community connections will be positively associated with adolescent perception of academic motivation and college and career readiness.

Method

Participants and Procedures

Original data were collected in 2016 via voluntary school participation in the use of the middle and high school version of the Community and Youth Collaborative Institute—School Experience Scales [CAYCI-SES], (Anderson-Butcher et al., 2013; Anderson-Butcher et al., 2020). The study author received approval from the university institutional review board to conduct secondary data analysis on collected information to date. Participants completed approximately 30-minute surveys during school hours, administered by school staff, resulting in an original sample that included 8,541 adolescents in grades 6-12, from 37 participating rural middle and high schools from the Midwest United States. The Office of Management and Budget (OMB; 2000) definition of rurality was used, which indicates that schools are in counties that

have less than 50,000 inhabitants and 84 percent of the land is classified as non-metropolitan. The OMB (2000) definition of rurality stipulates that schools located in counties with less than 50,000 inhabitants and 84 percent of the land classified as non-metropolitan are classified as rural. The racial and ethnic diversity of this sample was found to be representative of modern rural America (Dobis et al., 2021), with most respondents identifying as White (87.4%), followed by Black (3.7%) and Multiracial (2.9%). Nearly half (49%) of respondents identified as female and all participants ranged in age 11 to 20 years old, with the highest percentages reporting being 12-16 years old (age 12 = 17.8%; age 13 = 17.2%; age 14 = 15.4%; age 15 = 15.1%; age 16 = 13.7%). Approximately 46% of respondents reported receiving free or reduced-price lunches.

Measures

Variables included in this study were derived from the Community and Youth Collaborative Institute—School Experience Scales [CAYCI-SES] (Anderson-Butcher et al., 2013). This instrument has been used to assess school climate, culture, and student/family/community experiences at various school levels (Anderson-Butcher et al., 2020). The School Experience Surveys, along with other instruments developed by the Community and Youth Collaborative Institute (CAYCI), have been included in the United States Department of Education-funded National Center for Safe and Supportive Learning’s compendia of valid and reliable school climate measures (National Center on Safe and Supportive Learning Environments, n.d.). The following

descriptions include Cronbach's coefficient α which was used to calculate the internal consistency coefficients of continuous variable survey items. Previous research suggests that Cronbach's α levels of 0.70 or above indicate a reasonable measure of reliability or internal consistency of an instrument (Abraham & Barker, 2015; Taber, 2018).

Demographic Information

Study respondents provided demographic information including gender, race, grade level, age, their expectation for education level, average academic performance, family arrangement, number of schools attended, number of moves since starting school, and socioeconomic status. Family arrangement was assessed by asking students to note the number of adults they live with at any given time. Response options ranged from 1 (I don't live with parents, live with caretaker) to 6 (I live with both parents). Socioeconomic status was assessed by asking students to indicate whether they do or do not receive free or reduced-price lunches.

College and Career Readiness

The variable college and career readiness is defined as the extent to which secondary students perceive their self-efficacy and preparedness for postsecondary education and/or future careers (Anderson-Butcher et al., 2013). Respondent perception of college and career readiness was measured using responses to five distinct statements related to the construct (e.g., I am confident I will get the job that I want, I am aware of careers that match my interests, I set goals that will help me get to college). Respondents rated their degree of agreement with each statement using a 5-point Likert-type scale ranging from 1 (strongly disagree) to 5 (strongly agree). An average of the response scores from the five items was calculated and used as an indicator, with higher scores reflecting greater levels of college and career readiness. A Cronbach's alpha of $\alpha = 0.87$ was obtained for the college and career readiness scale for the current sample (Anderson-Butcher et al., 2013).

Academic Motivation

Academic motivation is defined as students' general interest, engagement, and enjoyment in learning and school (Anderson-Butcher et al., 2013). Respondent perception of academic motivation was measured using responses to six distinct statements related to this construct (e.g. I feel my school experience is preparing me well for adulthood, I like the challenges of learning new things in school).

Respondents rated their degree of agreement to each statement using a 5-point Likert-type scale ranging from 1 (strongly disagree) to 5 (strongly agree). An average of the response scores from the six items was calculated and used as an indicator of academic motivation, with higher scores reflecting greater levels of motivation. For the current study and sample, a Cronbach's alpha of $\alpha = 0.84$ was obtained for the academic motivation scale (Anderson-Butcher et al., 2013).

Internalizing Behaviors

The variable internalizing behavior, sometimes referred to as inhibited behaviors, is defined as feelings and behaviors that are dealt with internally, rather than by acting them out in the home or school (Anderson-Butcher et al., 2013). This construct was operationalized via responses to ten statements related to student emotions and mental health (e.g., In the past week I felt sad, in the past week people were not nice to me, and in the past week I felt worried). Respondents rated their degree of agreement to each statement using a 5-point Likert-type scale ranging from 1 (strongly agree) to 5 (strongly disagree). An average of the response scores from the ten items was calculated and used as an indicator of internalizing behaviors, with higher scores reflecting students reporting lower rates of negative internalizing behaviors (Anderson-Butcher et al., 2013). The internalizing behavior scale obtained a Cronbach's alpha of $\alpha = 0.92$.

Externalizing Behaviors

Defined as actions or behaviors physically exhibited or directed toward the external environment (Anderson-Butcher et al., 2013), externalized behavior scores were determined by responses to ten questions related to student behavior and actions directed towards people or property (e.g., have you ever been in a fight?, have you ever skipped schoolwork assignments?, have you ever bullied someone at school?). The degree of agreement with each question was signified using a 5-point Likert-type scale ranging from 1 (very often) to 5 (never). An average of the response scores from the ten items was calculated and used as an indicator of externalizing behaviors, with higher scores reflecting students reporting lower rates of negative behavior and actions (Anderson-Butcher et al., 2013). Summed and averaged responses generated the final variable score and a Cronbach's alpha of $\alpha = 0.84$ was obtained.

Peer Relationships

Peer relationships are defined as the extent to which middle and high school students feel they are supported by and have positive relationships with their peers (Anderson-Butcher et al., 2013). The peer relationships variable was measured via responses to six statements pertinent to the construct (e.g., My friends support and care about me, my friends are people whom I can trust, my friends do nice things for other people). Respondent's level of agreement with each item was measured using a 5-point Likert-type scale ranging from 1 (strongly disagree) to 5 (strongly agree). An average of the response scores from the six items was calculated and used as an indicator of peer relationships, with higher scores reflecting students perceiving more positive and supportive relationships with their peers (Anderson-Butcher et al., 2013). A final scale Cronbach's alpha of $\alpha = 0.86$ was obtained for this variable.

Parent Involvement/Support

Parental involvement and support is defined as the degree to which students feel that their parents and guardians are involved in their learning and support their educational growth (Anderson-Butcher et al., 2013). Respondent perception of parent involvement and support was measured using four statements indicative of this engagement (e.g., My parents help me with my schoolwork, my parents push me to work hard at school). Respondent level of agreement was measured using a 5-point Likert-type scale ranging from 1 (strongly disagree) to 5 (strongly agree). An average of the response scores from the four items was calculated and used as an indicator of parental involvement and support, with higher scores reflecting greater levels of involvement and support from parents or primary caregivers (Anderson-Butcher et al., 2013). A Cronbach's alpha of $\alpha = 0.88$ was obtained for the parent involvement and support variable.

Family/Community Connections

Family and community connections are defined as the extent to which students feel connected to their families and the broader community (Anderson-Butcher et al., 2013). Respondent perception of family and community connection was determined through responses to four statements posed similarly to the variables above (e.g., I have a sense of responsibility to the community I live in, there are responsible adults in my community who support and encourage me). An average of the response scores from the four items was calculated and used as an indicator of family and community connections, with

higher scores reflecting greater levels of experienced connectedness. A 5-point Likert-type scale ranging from 1 (strongly disagree) to 5 (strongly agree) was used to assess the level of agreement with each item (Anderson-Butcher et al., 2013). A Cronbach's alpha of $\alpha = 0.86$ was obtained for this variable.

Analysis

In preparation for data analysis, missing data patterns were explored. All model variables demonstrated 96% or greater present values. Logistic regression models for testing missing data patterns were conducted. All variables yielded null results, except for externalizing behavior and gender. For every one unit increase in negative externalizing behaviors, there was a 43% decrease in the odds of participants responding to college and career readiness questions ($OR = 0.57$, $SE = 0.11$, $z = -2.83$, $p = 0.01$, $95\% CI = 0.39, 0.84$) and respondents who self-identified as male demonstrated a 66% decrease in odds of responding to college and career readiness questions ($OR = 0.34$, $SE = 0.12$, $z = -3.17$, $p = 0.001$, $95\% CI = 0.17, 0.66$). These variables were included in the model, and each contained less than 5% missing data. Based on the presence of significant predictors of missingness, data could not be considered missing at random. However, both significant predictors of missingness were controlled for within the model, and therefore the use of full information maximum likelihood estimation was employed (Schafer & Graham, 2002). This approach uses all available data to generate parameter and standard error estimates while accounting for missing data (McArdle, 2013).

All model assumptions of a multivariate multiple linear regression were examined before data analysis. Linearity was examined using Pearson correlations between all continuous independent variables and the dependent variables of academic motivation and college and career readiness, with all correlations ranging from .27 to .61 and significant at .001, suggesting that the assumption of linearity was met. Further, previous scholarship indicates a distinct connection between adolescent academic motivation and college and career readiness (Brown & Lent, 2019; Conley, 2012; Conley & French, 2014), which may manifest differently in the context of unique personal and contextual school experiences of rural adolescents. Therefore, this study also identified the correlation between rural adolescent academic motivation and college and career readiness (0.61 , $p < .001$) in the proposed model.

Normality was examined among all continuous variables with skew and kurtosis values for all variables falling below absolute values of 2 (skew)

and 7 (kurtosis) indicating appropriate normality. Homoscedastic model assumptions were violated, requiring the use and interpretation of robust standard errors within the final model. There were no issues of multicollinearity present for variables included in this study (all variance inflation factors [VIF] < 2; O'Brien, 2007), and all variables appeared to be appropriately measured as indicated by no visible outliers.

Using Mplus 8 (Muthén & Muthén, 1998-2017), a multivariate multiple linear regression analysis was conducted to identify the association between five school experience independent variables and two dependent variables—academic motivation and college and career readiness. The CLUSTER command was used to account for the nested data structure. Further, intraclass correlation coefficients (ICCs) were computed to determine the amount of dependence among observations within groups (Shrout & Fleiss, 1979). The ICC suggested that only 2% of the variance in college and career readiness (ICC = 0.02, SE = 0.01, $p < 0.001$, 95% CI = 0.01, 0.04) and only 4% of the variance in academic motivation (ICC = 0.04, SE = 0.01, $p < 0.001$, 95% CI = 0.03, 0.07) after adjusting for all model covariates, can be explained by school building level. Scholars have suggested that ICC values below 0.5 indicate poor reliability (Koo & Li, 2016; Kul et al., 2014), thus a two-level model is not supported. The means, standard deviations, and correlations of study variables are presented in Table 1.

Examination of standardized multivariate multiple linear regression coefficients revealed several significant associations with rural adolescent perceptions of *academic motivation*. These included high levels of internalized behavior ($\beta = 0.120$, $p = .000$), externalized behavior ($\beta = 0.159$, $p = .000$), peer relationships ($\beta = 0.257$, $p = .000$), parental involvement and support ($\beta = 0.060$, $p = .000$), and family/community connections ($\beta = 0.171$, $p = .000$). In this sample, gender ($\beta = 0.029$, $p = .022$) and

socioeconomic status ($\beta = -0.055$, $p = .000$) were also identified as significant predictors of adolescent perceptions of academic motivation.

Final model coefficients also revealed several significant predictors of rural adolescent perceptions of *college and career readiness*. Internalized behavior ($\beta = 0.070$, $p = 0.000$), externalized behavior ($\beta = 0.132$, $p = .000$), peer relationships ($\beta = 0.292$, $p = .000$), parental involvement and support ($\beta = 0.078$, $p = .000$), and family/community connections ($\beta = 0.173$, $p = .000$) were each identified as significant at the .001 level. In this sample, gender ($\beta = 0.035$, $p = .005$) and family arrangement ($\beta = -0.021$, $p = 0.040$) were identified as significant predictors of adolescent perceptions of college and career readiness.

Results

F-tests indicated a good fit to the data for both college and career readiness ($df = 9$, $p < .001$, $R^2 = 0.32$) and academic motivation ($df = 9$, $p < .001$, $R^2 = 0.33$). Therefore 32% of the variance in college and career readiness and 33% of the variance in academic motivation was accounted for by all variables included in the model. Complete model results including standardized regression coefficients, standard error, *p*-value, and confidence intervals can be seen in Table 2.

To summarize the results, adolescents who indicated having higher (more positive) levels of internalized and externalized behaviors, peer relationships, parental involvement and support, and family/community connections also indicated higher levels of academic motivation and college and career readiness. These findings support the current study hypotheses that, informed by previous research, anticipated a positive impact derived from increased adolescent mental and behavioral health, as well as positive, prosocial connections with peers,

Table 1
Means, standard deviation, and variable correlations

Variable	<i>M</i>	<i>SD</i>	1	2	3	4	5	6
1. College/career readiness	3.96	0.86						
2. Academic motivation	3.65	0.77	.61*					
3. Internalizing behavior	3.74	1.01	.27*	.31*				
4. Externalizing behavior	4.23	0.63	.37*	.40*	.34*			
5. Peer Relationships	3.83	0.78	.49*	.47*	.30*	.41*		
6. Parental Involvement and Support	3.59	1.07	.32*	.31*	.20*	.22*	.30*	
7. Family and Community Connections	3.57	1.02	.39*	.39*	.30*	.25*	.37*	.61*

Note. $N = 8,541$. *M* = mean. *SD* = standard deviation. * = $p < .001$.

Table 2

Multivariate multiple linear regression analysis of academic motivation and college and career readiness.

Dependent Variables	β	SE	<i>p</i>	95% CI	
				<i>LL</i>	<i>UL</i>
Academic Motivation					
Gender	0.029	0.013	.022*	0.007	0.088
Race	-0.012	0.009	.179	-0.016	0.003
Age	0.024	0.032	.462	-0.17	0.037
Family Structure	-0.006	0.008	.465	-0.010	0.005
Socioeconomic status	-0.055	0.012	.000***	-0.128	-0.053
Internalized behaviors	0.120	0.017	.000***	0.067	0.119
Externalized behaviors	0.159	0.016	.000***	0.141	0.215
Peer relationships	0.257	0.031	.000***	0.194	0.315
Parental involvement & support	0.060	0.026	.024*	0.006	0.083
Family/community connections	0.171	0.051	.001***	0.056	0.213
College & Career Readiness					
Gender	0.035	0.013	.005**	0.019	0.108
Race	-0.002	0.008	.786	-0.010	0.008
Age	0.016	0.021	.455	-0.012	0.026
Family Structure	-0.021	0.010	.040*	-0.023	-0.001
Socioeconomic status	0.011	0.009	.235	-0.013	0.053
Internalized behaviors	0.070	0.020	.001***	0.026	0.094
Externalized behaviors	0.132	0.015	.000***	0.126	0.200
Peer relationships	0.292	0.032	.000***	0.246	0.386
Parental involvement & support	0.078	0.028	.006**	0.019	0.109
Family/community connections	0.173	0.050	.001***	0.065	0.233

Note. * $p < .05$. ** $p < .01$. *** $p < .001$.

family, and their wider communities. Further, demographic variables of gender, age, and socioeconomic status were found to play a significant role in adolescent perception of academic motivation. Adolescent perception of college and career readiness was significantly impacted by gender and family arrangement.

Discussion

Grounded in social cognitive career theory (Lent et al., 1994) and expectancy value theory (Eccles et al., 1983), this study examined influential contextual factors on the educational and career aspirations of rural adolescents. It is further informed by college and career readiness scholarship focused on personal and contextual factors impacting youth preparation for postsecondary pathways (Conley, 2010; Perna, 2006). The work of Ali and colleagues (2019; 2021) and others (Byun et al., 2012a; Byun et al., 2012b; Chambers et al., 2019) provided critical insight into the experiences of rural adolescents and the cultural, contextual, and educational barriers they face in preparation for life beyond high school. Given that person and contextual variables interrelate and impact educational and career interests (Lent et al., 1994) and self-efficacy beliefs and behaviors (Eccles & Wigfield, 2002), this study aimed to examine the

relationship between several personal and contextual variables and adolescents' perceptions of their academic motivation and college and career readiness. Academic motivation and college and career readiness have been identified as critical constructs to the postsecondary success and attainment of adolescents (Conley, 2012; Gaertner & McClarty, 2015; McCoy & Bowen, 2015). This study extends this previous scholarship by identifying several factors that significantly predicted perceptions of academic motivation and college and career readiness within a large sample of adolescents from rural communities in the Midwest United States.

Adolescent internalized behavior (e.g., feeling sad, lonely, shy) was identified as a significant influencing factor on the perception of postsecondary readiness. The positive association between internalized behaviors and both academic motivation and college and career readiness corroborates previous scholarship by Gueldner and colleagues (2020) who posited that adolescent mental health and stability influence their ability to succeed both socially and academically. Adolescent mental and emotional state has also been identified as influential to aspirations and purposeful planning (Fredricks et al., 2019; Gueldner et al., 2020) which can impact the

drive to succeed and prepare for either career or continued education (McCoy & Bowen, 2015). For adolescents from rural contexts, this may be particularly relevant as certain social and emotional challenges are more prevalent in more isolated, under-resourced communities (Corbett & Forsey, 2017; Tieken, 2014).

Adolescent mental health and emotional state are often related to and revealed through outward actions and behavior (Olfson et al., 2015; Taylor et al., 2017). Subsequently, the externalized behaviors and actions of adolescents (e.g., being bullied, bullying, skipping school) and their subsequent repercussions impact their school experience and subsequent feelings about learning, future aspirations, and achievement (Duncan et al., 2017). The current study corroborates these findings and demonstrates a significant and positive effect on academic motivation and college and career readiness when adolescents exhibited lower frequencies of negative behavior and action (i.e., externalized behavior). Of note, the current study findings indicated that rural adolescents' perception of academic motivation is more significantly impacted by externalized behaviors than their perceptions of college and career readiness. This suggests that negative externalized behaviors may shape rural adolescent academic motivation, however, the longer-term impact of externalized behavior on goals and perceptions of postsecondary preparation is less severe.

Additionally, the results from this study indicated that peer relationships, more than any other demographic or social cognitive career theory variables, have the strongest association with adolescent perceptions of academic motivation and college and career readiness. This is indicative of the influence that healthy, positive, prosocial peer relationships have on the postsecondary paths that adolescents aspire to and strive for. Previous scholarship suggests that relationships with peers and friends become particularly critical as students enter middle school and beyond (e.g., Li et al., 2011; Wentzel, 2017; Williams & Anthony, 2015). Adolescent social relationships, within-group networks, and supportive social structures have also begun to be identified as a core component of school climate research and linked with several student success outcomes, including self-esteem, reduced substance abuse, school connectedness, and engagement in learning (Demaray et al., 2012; Jimerson et al., 2012; Kutsyruba et al., 2015; Thapa et al., 2013).

Furthermore, findings from the current study indicated a significant association between parental involvement and support and rural adolescent perceptions of their academic motivation and college

and career readiness. This corroborates previous research from non-rural contexts that demonstrates the positive impact parental inclusion in adolescent preparation and planning within K-12 settings can have on their immediate academic success (Liang et al., 2021; Perna & Titus, 2005; Ross, 2016). Parental or caregiver involvement has been further identified as impacting awareness and investment in various paths after graduation (Gilfillan et al., 2021; Perna & Titus, 2005). Of note in this study, the relationship between parental involvement and support and adolescent academic motivation and college and career readiness was substantially less than other variables (e.g., peer relationships, family/community connections). These findings provide insight into the degree to which external variables play a role in postsecondary aspiration and readiness. Further, they indicate that, amongst this age group, parent or caregiver relationships may not be as critical for schools to focus on in support of student success as other external, contextual variables such as prosocial peer relationships or connections to individuals and experiential learning opportunities within the broader community.

Lastly, family and community connections, understood as a sense of belonging amongst family and a sense of responsibility and connection to a community (Nelson, 2016), also emerged as positively significantly associated with rural adolescent academic motivation and college and career readiness. Past research has indicated the social and cultural structure often present within small, rural communities have an impact on the way that adolescents and families might view opportunities, aspirational goals, and pathways that lie outside of the community they know (Alleman & Holly, 2013; Ardoin, 2017; Tieken, 2014). Like parental involvement and support, family and community connections were found to have a weaker association with postsecondary motivation and readiness relative to peer relationships.

Participant gender was found to have a significant positive association with both rural adolescent academic motivation and college and career readiness perceptions. This finding aligns with previous research indicating the pervasive influence that gender roles and expectations have on academic and social paths adolescents might take (Agger, 2016; Meece et al., 2006; Meece et al., 2014), as well as the strength and nature of external, relationship factors (i.e., peer relationships, family/community connections) (Chenoweth & Galliher, 2004; Li et al., 2011). Family arrangement was found to have a slight negative association with college and career readiness, while participant age was identified as having a slight positive association with academic

motivation. The former corroborates scholarship that posits the important role that conflict-free or stable household environments as well as parental influence and involvement have on adolescent developmental outcomes (Gilfillan et al., 2021; Liang et al., 2021; Wu et al., 2015). The latter, participant age, appears indicative of the role that rural student age plays in their motivation to succeed academically. This may be due to exposure to a more rigorous and diverse curriculum as students advance through high school and that postsecondary pathways become more tangible and relevant to their lives and goals.

Significance

The current study provides significant and unique contributions in several ways. First, by specifically centering the experiences and individual factors of rural adolescents, a clearer picture of this underrepresented population is drawn. Further, a greater understanding of the strength and nature of various personal and contextual factors that shape rural adolescent postsecondary success is provided. Specifically, this study explored various internal and external factors that shape perceptions of academic motivation and college and career readiness of a large sample of rural adolescents.

Study findings support previous scholarship indicating an association between adolescent internalized behavior and externalized behavior and perception of their academic motivation and college and career readiness. Yet a gap in understanding remained regarding the strength of association between these variables. The current findings address this knowledge gap in that they indicated a stronger influence on both academic motivation and college and career readiness stemming from externalized behaviors, relative to adolescent internalized behaviors. Contextual factors including peer relationships, parental involvement, and familial and community connection also had significant, positive impacts on adolescent perceptions of their academic motivation and college and career readiness. Like adolescent personal factors (i.e., internalized and externalized behaviors), the strength of association between contextual factors and adolescent postsecondary motivation and readiness was less understood. Perhaps most significant are study findings indicating that peer relationships, more than any other individual or contextual variables, hold the strongest association with rural adolescent motivation and readiness in this sample. Collectively, this study demonstrates the role that adolescent social and emotional health, along with social support and connection, has on their aspirations, goal setting, and choices regarding postsecondary pathways.

The current study's findings give educators and schools a clear picture of the various elements impacting rural students, while simultaneously providing a clear sense of the elements that are most critical to supporting student success (e.g., fostering prosocial, supportive peer relationships and school climates). This information can help educators prioritize the scope and nature of targeted interventions and support within rural schools. For under-resourced, rural schools this may include interventions that provide a multifaceted approach and address multiple school issues and student support issues at the same time. One example is the My Teaching Partner – Secondary (MTP-S) program, a teacher professional development intervention aimed at supporting positive interactions with students and more sensitive instructional practices. Research has indicated that this type of intervention supports student academic motivation and achievement through more positive interactions with teachers, and simultaneously supports positive, prosocial behaviors and interactions between peers (Mikami et al., 2011). Similarly, age-specific interventions including Second Step: Student Success Through Prevention (SS-SSTP) Middle School Program not only target key developmental ages but have included research that supports interventions that address multiple issues (Espelage & Colbert, 2016). Interventions such as these can reduce the need for separate approaches and programming that can be costly and time-consuming.

Finally, although it was not the original aim of the current investigation, study findings hold particularly salient implications for educators and schools in our current age and considering the COVID-19 pandemic. As schools have fully reopened and PK-12 students have returned full-time to classrooms across the United States, educators and school professionals are faced with many students demonstrating significant social and emotional deficits. The socialization, learning, and development that happens through peer relationships and interactions were removed for large periods for so many students and the repercussions of necessary isolation from others are only beginning to emerge. Findings from this study show that inclusion and connection with others are critical to student success, but that peer relationships specifically wield a positive influence that can determine a student's motivation and preparation for their future. This lends empirical support to what many parents, educators, and school systems are learning first-hand in the post-COVID era and guides ways to provide specific support and intervention for students.

Limitations and Future Research

This study is not without limitations, however, these illuminate ways in which future research might build upon the current findings and carry forward the conversation around rural adolescent postsecondary readiness and motivation. There are three primary limitations to the current investigation. First, the cross-sectional nature of the current study offers only a snapshot in time regarding student perceptions of postsecondary readiness and academic motivation. As indicated by Lent and Brown (2013), the factors and influences on adolescent experiences during the K-12 years can and often do fluctuate and shift, impacting goals and aspirations. Future research taking a longitudinal approach tracking changing circumstances of rural adolescents alongside changes in perception of motivation and readiness and inclusive of postsecondary outcomes may provide more nuanced information on key influential factors. Second, despite its large size, study respondents originated from the same geographic area with homogenous demographic features (e.g., race, culture, industry). Future research would benefit from the purposeful inclusion of more racially, geographically, and culturally diverse rural populations, resulting in greater generalizability across rural communities and contexts in the United States. Lastly, the instrument used for data collection in this study was developed for use by practitioners at a time when more nuanced demographic information may not have been sought. With time has come an increased understanding of the varying identities and measures of self-perception that exist among adolescents. Future research would benefit from an updated instrument that includes diverse gender identities and sexual orientations, as well as more inclusive race, ethnicity, and family structure options. Further, updates to survey language regarding adolescent perceptions of certain constructs (e.g., internalized and externalized behavior) could be

made to ensure that connotations and conceptual orders are not misunderstood and more accurate perceptions of noncognitive constructs can be gathered.

Conclusion

This study provides insight into various influential factors on the perceptions of academic motivation and college and career readiness of rural adolescents. Specifically, findings support previous scholarship that notes a critical connection between adolescents' internalized and externalized behaviors, social and academic development (Gueldner et al., 2020; Taylor et al., 2017), and ultimately their academic motivation and college and career readiness. Study results suggest that for rural schools to effectively prepare their students for successful pathways beyond graduation, efforts in support of student mental health and prosocial relationships must be undertaken. Findings also shed further light on the influence on postsecondary perceptions that come from contextual factors (e.g., peer relationships, family, and community connection). Findings support previous scholarship noting that peer relationships are influential in adolescent social and academic success (e.g., Wentzel, 2017; Williams & Anthony, 2015). In this study, peer relationships demonstrate the most influence on perceptions of academic motivation and college and career readiness. Thus, a more systematic investigation into this variable's path of influence on rural adolescents may help demonstrate the necessity of focusing on or developing rural school practices that promote healthy, supportive, prosocial relationships. As rural schools invest time and effort into such practices and investigate the various elements influencing their students' perceptions of motivation and postsecondary readiness, gaps between aspiration and attainment may be lessened.

References

- Abraham, J., & Barker, K. (2015). Exploring gender difference in motivation, engagement and enrolment behaviour of senior secondary physics students in New South Wales. *Research in Science Education, 45*(1), 59-73. <https://doi.org/10.1007/s11165-014-9413-2>
- Agger, C. (2016). Fleeing the nest or staying close? How perceptions of family and place shape the postsecondary enrollment of rural men and women. <https://doi.org/10.17615/a6r9-he57>
- Agger, C., Meece, J., & Byun, S. Y. (2018). The influences of family and place on rural adolescents' educational aspirations and post-secondary enrollment. *Journal of Youth and Adolescence, 47*(12), 2554-2568. <https://doi.org/10.1007/s10964-018-0893-7>
- Ahn, J. S., Plamondon, A., & Ratelle, C. F. (2022). Different ways to support and thwart autonomy: Parenting profiles and adolescents' career decision-making. *Journal of Family Psychology, 36*(1), 1-11. <https://doi.org/10.1037/fam0000982>
- Alleman, N. F., & Holly, N. L. (2013). Multiple points of contact: Promoting rural postsecondary preparation through school-community partnerships. *The Rural Educator, 34*(2). <https://doi.org/10.35608/ruraled.v34i2.398>

- Ali, S. R., Loh Garrison, Y., Cervantes, Z. M., & Dawson, D. A. (2021). Sociopolitical development and healthcare career interest, self-efficacy, and outcome expectations among rural youth. *Counseling Psychologist, 49*(5), 701-727. <https://doi.org/10.1177/00110000211007440>
- Ali, S. R., Pham, A., Loh Garrison, Y., & Brown, S. D. (2019). Project HOPE: Sociopolitical development and SCCT beliefs of Latinx and White rural middle school students. *Journal of Career Development, 46*(4), 410-424. <https://doi.org/10.1177/0894845319832973>
- Anderson-Butcher, D., Amorose, A. J., Iachini, A. L., & Ball, A. (2013). *Community and youth collaborative institute school experience surveys: Middle & high school student survey*. College of Social Work, The Ohio State University.
- Anderson-Butcher, D., Amorose, A., Bates, S. M., Iachini, A. L., Ball, A., & Henderson, T. (2020). Driving school improvement planning with community and youth collaborative institute school experience surveys (CAYCI-SES). *Children & Schools, 42*(1), 7-17. <https://doi.org/10.1093/cs/cdz028>
- Anderson, R., & Chang, B. (2011). Mathematics course-taking in rural high schools. *Journal of Research in Rural Education, 26*(1), 1-10. <https://jrre.psu.edu/volume/26>.
- Ardoin, S. (2017). *College aspirations and access in working-class rural communities: The mixed signals, challenges, and new language first-generation students encounter*. Lexington Books.
- Bandura, A. (1986). *Social foundations of thought and action: A social cognitive theory*. Prentice-Hall.
- Bandura, A., Barbaranelli, C., Caprara, G. V., & Pastorelli, C. (2001). Self-efficacy beliefs as shapers of children's aspirations and career trajectories. *Child Development, 72*(1), 187-206. <https://doi.org/10.1111/1467-8624.00273>
- Bottiani, J. H., Bradshaw, C. P., & Mendelson, T. (2016). Inequality in Black and White high school students' perceptions of school support: An examination of race in context. *Journal of Youth and Adolescence, 45*(6), 1176-1191. <https://doi.org/10.1007/s10964-015-0411-0>
- Brown, R., Copeland, W. E., Costello, E. J., Erkanli, A., & Worthman, C. M. (2009). Family and community influences on educational outcomes among Appalachian youth. *Journal of Community Psychology, 37*, 795-808. <https://doi.org/10.1002/jcop.20331>
- Brown, S. D., & Lent, R. W. (2019). Social cognitive career theory at 25: Progress in studying the domain satisfaction and career self-management models. *Journal of Career Assessment, 27*(4), 563-578. <https://doi.org/10.1177/2F1069072719852736>
- Bugler, M., McGeown, S. P., & St Clair-Thompson, H. (2015). Gender differences in adolescents' academic motivation and classroom behaviour. *Educational Psychology, 35*(5), 541-556. <https://doi.org/10.1080/01443410.2013.849325>
- Bugler, M., McGeown, S., & St Clair-Thompson, H. (2016). An investigation of gender and age differences in academic motivation and classroom behaviour in adolescents. *Educational Psychology, 36*(7), 1196-1218. <https://doi.org/10.1080/01443410.2015.1035697>
- Byun, S. Y., Irvin, M. J., & Meece, J. L. (2015). Rural-nonrural differences in college attendance patterns. *Peabody Journal of Education, 90*(2), 263-279. <https://doi.org/10.1080/0161956X.2015.1022384>
- Byun, S. Y., Meece, J. L., & Irvin, M. J. (2012a). Rural-nonrural disparities in postsecondary educational attainment revisited. *American Educational Research Journal, 49*(3), 412-437. <https://doi.org/10.3102/0002831211416344>
- Byun, S. Y., Meece, J. L., Irvin, M. J., & Hutchins, B. C. (2012b). The role of social capital in educational aspirations of rural youth. *Rural Sociology, 77*(3), 355-379. <https://doi.org/10.1111/j.1549-0831.2012.00086.x>
- Camara, W. (2013). Defining and measuring college and career readiness: A validation framework. *Educational Measurement: Issues and Practice, 32*(4), 16-27. <https://doi.org/10.1111/emip.12016>
- Chambers, C., Crumb, L., & Harris, C. (2019). A call for dreamkeepers in rural United States: Considering the postsecondary aspirations of rural ninth graders. *Theory & Practice in Rural Education, 9*(1), 7-22. <https://doi.org/10.3776/tpre.2019.v9n1p7-22>
- Chenoweth, E., & Galliher, R. V. (2004). Factors influencing college aspirations of rural West Virginia high school students. *Journal of Research in Rural Education, 19*(2), 1-14. <https://jrre.psu.edu/volume/19>
- Conley, D. T. (2010). *College and career ready: Helping all students succeed beyond high school*. John Wiley & Sons. <https://doi.org/10.1002/9781118269411>
- Conley, D. T. (2012). A complete definition of college and career readiness. *Educational Policy Improvement Center (NJ1)*. <https://eric.ed.gov/?id=ED537876>
- Conley, D. T., & French, E. M. (2014). Student ownership of learning as a key component of college readiness. *American Behavioral*

- Scientist*, 58(8), 1018–1034.
<https://doi.org/10.1177/0002764213515232>
- Cooper, C. R., & Cooper Jr, R. G. (2016). Links between adolescents' relationships with their parents and peers: Models, evidence, and mechanisms. In D. Parke and G. Ladd (Eds.) *Family-Peer Relationships* (pp. 149-172). Routledge. <https://doi.org/10.4324/9781315625928>
- Corbett, M., & Forsey, M. (2017). Rural youth out-migration and education: Challenges to aspirations discourse in mobile modernity. *Discourse: Studies in the Cultural Politics of Education*, 38(3), 429-444.
<https://doi.org/10.1080/01596306.2017.1308456>
- Crawley, K. J., Cheuk, C. T., Mansoor, A., Perez, S. M., & Park, E. (2019). A proposal for building social capital to increase college access for low-income students. *Journal of Educational Leadership and Policy Studies*, 3(1), 1-14.
<https://eric.ed.gov/?id=EJ1226937>
- Davis-Keane, P. E. (2005). The influence of parent education and family income on child achievement: The indirect role of parental expectations and the home environment. *Journal of Family Psychology*, 19(2), 294-304.
<https://doi.org/10.1037/0893-3200.19.2.294>
- Deković, M., & Meeus, W. (1997). Peer relations in adolescence: Effects of parenting and adolescents' self-concept. *Journal of Adolescence*, 20(2), 163-176.
<https://doi.org/10.1006/jado.1996.0074>
- Demaray, M., Malecki, C. & Jenkins, L. (2012) Social support in the lives of students involved in aggressive and bullying behaviours. In S. Jimerson, A. Nickerson, M. Mayer & M. Furlong (Eds.) *Handbook of School Violence and School Safety: International Research and Practice*, (2nd ed., pp. 57–67). Routledge.
- Demi, M. A., Coleman-Jensen, A., & Snyder, A. R. (2010). The rural context and post-secondary school enrollment: An ecological systems approach. *Journal of Research in Rural Education*, 25(7), 1-26.
<http://jrre.psu.edu/articles/25-7.pdf>
- Dika, S. L., & Singh, K. (2002). Applications of Social Capital in Educational Literature: A Critical Synthesis. *Review of Educational Research*, 72(1), 31–60.
<https://doi.org/10.3102/00346543072001031>
- Dobis, E. A., Krumel, T. P., Cromartie, J., Conley, K. L., Sanders, A., & Ortiz, R. (2021). *Rural America at a Glance: 2021 Edition* (No. 316344). United States Department of Agriculture. <http://dx.doi.org/10.22004/ag.econ.316344>
- Duncan, R., Washburn, I. J., Lewis, K. M., Bavarian, N., DuBois, D. L., Acock, A. C., ... & Flay, B. R. (2017). Can universal SEL programs benefit universally? Effects of the positive action program on multiple trajectories of social-emotional and misconduct behaviors. *Prevention Science*, 18(2), 214-224.
<https://doi.org/10.1007/s11121-016-0745-1>
- Durlak, J. A., Weissberg, R. P., Dymnicki, A. B., Taylor, R. D., & Schellinger, K. B. (2011). The impact of enhancing students' social and emotional learning: A meta-analysis of school-based universal interventions. *Child Development*, 82(1), 405-432.
<https://doi.org/10.1111/j.1467-8624.2010.01564.x>
- Eccles Parsons, J. S., Adler, T. F., Futterman, R., Goff, S. B., Kaczala, C. M., Meece, J. L., & Midgley, C. (1983). Expectancies, values, and academic behaviors. In J. T. Spence (Ed.), *Achievement and Achievement Motivation* (pp. 75-146). W. H. Freeman.
- Eccles, J. S., & Wigfield, A. (2002). Motivational beliefs, values, and goals. *Annual Review of Psychology*, 53(1), 109-132.
<https://doi.org/10.1146/annurev.psych.53.100901.135153>
- Espelage, D. L., & Colbert, C. L. (2016). School-based interventions to prevent bullying and promote prosocial behaviors. In K. Wentzel & G. Ramani (Eds.) *Handbook of Social Influences in School Contexts: Social-emotional, Motivation, and Cognitive Outcomes*, (pp. 405-422). Routledge.
- Fan, W., Williams, C. M., & Wolters, C. A. (2012). Parental involvement in predicting school motivation: Similar and differential effects across ethnic groups. *The Journal of Educational Research*, 105(1), 21-35.
<https://doi.org/10.1080/00220671.2010.515625>
- Fredricks, J. A., Blumenfeld, P. C., & Paris, A. H. (2004). School engagement: Potential of the concept, state of the evidence. *Review of Educational Research*, 74(1), 59-109.
<https://doi.org/10.3102%2F00346543074001059>
- Fredricks, J. A., Parr, A. K., Amemiya, J. L., Wang, M. T., & Brauer, S. (2019). What matters for urban adolescents' engagement and disengagement in school: a Mixed-Methods Study. *Journal of Adolescent Research*, 34(5), 491-527.
<https://doi.org/10.1177%2F0743558419830638>
- Gaertner, M. N., & McClarty, K. L. (2015). Performance, perseverance, and the full picture of college readiness. *Educational Measurement:*

- Issues and Practice*, 34(2), 20-33.
<https://doi.org/10.1111/emip.12066>
- Gibbons, M. M., Brown, E. C., Daniels, S., Rosecrance, P., Hardin, E. E., & Farrell, I. (2019). Building on strengths while addressing barriers: Career interventions in rural Appalachian communities. *Journal of Career Development*, 46(6), 637-650.
<https://doi.org/10.1177/0894845319827652>
- Gibbons, M. M., Taylor, A. L., Brown, E., Daniels, S. K., Hardin, E. E., & Manring, S. (2020). Assessing postsecondary barriers for rural Appalachian high school students. *Journal of Career Assessment*, 28(1), 165-181.
<https://doi.org/10.1177%2F1069072719845329>
- Gilfillan, B. H., Das, B., Erickson, D., & Gupta, K. (2021). Involving families in the postsecondary planning process: A case study. *Professional School Counseling*, 25(1), 1-12.
<https://doi.org/10.1177/2156759X211050413>
- Gueldner, B. A., Feuerborn, L. L., & Merrell, K. W. (2020). *Social and emotional learning in the classroom: Promoting mental health and academic success*. Guilford Publications.
- Gray, K. (2009). *Getting real: Helping teens find their future* (2nd ed.). Corwin Press.
- Griffin, D., Hutchins, B. C., & Meece, J. L. (2011). Where do rural high school students go to find information about their futures?. *Journal of Counseling & Development*, 89(2), 172-181.
<https://doi.org/10.1002/j.1556-6678.2011.tb00075.x>
- Hardré, P. L. (2012). Standing in the gap: Research that informs strategies for motivating and retaining rural high school students. *The Rural Educator*, 34(1), 12-18. Retrieved from:
<https://files.eric.ed.gov/fulltext/EJ1000099.pdf>
- Henry, C. S., Plunkett, S. W., & Sands, T. (2011). Family structure, parental involvement, and academic motivation in Latino adolescents. *Journal of Divorce & Remarriage*, 52(6), 370-390. <https://doi.org/10.1080/10502556.2011.592414>
- Hill J. & Turney, J. S. (2016). National Rural Education Association (NREA) research agenda – 2016-2021. *The Rural Educator*, 37(3), v-vii.
<https://doi.org/10.35608/ruraled.v42i2.1244>
- Howley, C. W. (2006). Remote possibilities: Rural Children's educational aspirations." *Peabody Journal of Education* 81(2), 62-80.
https://doi.org/10.1207/S15327930pje8102_4
- Jiang, Y., Rosenzweig, E. Q., & Gaspard, H. (2018). An expectancy-value-cost approach in predicting adolescent students' academic motivation and achievement. *Contemporary Educational Psychology*, 54, 139-152.
<https://doi.org/10.1016/j.cedpsych.2018.06.005>
- Jimerson, S. R., Hart, S. R., & Renshaw, T. L. (2012). Conceptual foundations for understanding youth engaged in antisocial and aggressive behaviors. In S. Jimerson, A. Nickerson, M. J. Mayer, M. J. Furlong (Eds.), *Handbook of School Violence and School Safety* (pp. 22-33). Routledge.
- Johnson, H., & Wiener, R. (2017). *This Time, with Feeling: Integrating Social and Emotional Development and College-and Career-Readiness Standards*. Aspen Institute.
<https://eric.ed.gov/?id=ED577037>
- Kindermann, T. A. (2016). Peer group influences on students' academic motivation. In K. Wentzel and G. Ramani (Eds.), *Handbook of Social Influences in School Contexts: Social-emotional, Motivation, and Cognitive Outcomes*, (pp. 31-47). Routledge.
- Koo, T. K., & Li, M. Y. (2016). A guideline of selecting and reporting intraclass correlation coefficients for reliability research. *Journal of Chiropractic Medicine*, 15(2), 155-163.
<https://doi.org/10.1016/j.jcm.2016.02.012>
- Koricich, A., Chen, X., & Hughes, R.P. (2018). Understanding the effects of rurality and socioeconomic status on college attendance and institutional choice in the United States. *The Review of Higher Education* 41(2), 281-305.
<https://doi.org/10.1353/rhe.2018.0004>
- Ladd, G. W., & Kochenderfer-Ladd, B. (2019). Parents and children's peer relationships. In M. Bornstein (Ed.), *Handbook of Parenting*, (pp. 278-315). Routledge.
<https://doi.org/10.4324/9780429401695>
- Lent, R. W., & Brown, S. D. (2013). Social cognitive model of career self-management: Toward a unifying view of adaptive career behavior across the life span. *Journal of Counseling Psychology*, 60(4), 557-568. <https://doi.org/10.1037/a0033446>
- Lent, R. W., Brown, S. D., & Hackett, G. (1994). Toward a unifying social cognitive theory of career and academic interest, choice, and performance. *Journal of Vocational Behavior*, 45(1), 79-122.
<https://doi.org/10.1006/jvbe.1994.1027>
- Lerner, J. B., & Deeds, C. (2018). How out-of-school time can support college and career readiness through social and emotional learning. In E. Devaney and D. Moroney (Eds.), *Social and Emotional Learning in Out-Of-School Time: Foundations and Futures*, (pp. 125-146). Information Age Publishing, Inc.
- Li, Y., Doyle Lynch, A., Kalvin, C., Liu, J., & Lerner, R. M. (2011). Peer relationships as a

- context for the development of school engagement during early adolescence. *International Journal of Behavioral Development*, 35(4), 329-342. <https://doi.org/10.1177%2F0165025411402578>
- Liang, Y., Zhou, N., Cao, H., Li, J. B., Dou, K., Wu, F., ... & Wang, G. (2021). Configuration of parent-reported and adolescent-perceived career-related parenting practice and adolescents' career development: A person-centered, longitudinal analysis of Chinese parent-adolescent dyads. *Journal of Child and Family Studies*, 1-14. <https://doi.org/10.1007/s10826-021-02135-7>
- Liu, Y. (2015). The longitudinal relationship between Chinese high school students' academic stress and academic motivation. *Learning and Individual Differences*, 38, 123-126. <https://doi.org/10.1016/j.lindif.2015.02.002>
- Martin, A. J. (2010). Should students have a gap year? Motivation and performance factors relevant to time out after completing school. *Journal of Educational Psychology*, 102(3), 561-576. <https://doi.org/10.1037/a0019321>
- McArdle, J. J. (2013). Dealing with longitudinal attrition using logistic regression and decision tree analyses. In J. J. McArdle & G. Ritschard (Eds.), *Contemporary issues in exploratory data mining in the behavioral sciences* (pp. 282-311). Taylor & Francis.
- McCarron, G.P., & Inkelas, K.K. (2006). The gap between educational aspirations and attainment for first-generation college students and the role of parental involvement. *Journal of College Student Development* 47(5), 534-549. <https://doi.org/10.1353/csd.2006.0059>
- McCoy, H., & Bowen, E. A. (2015). Hope in the social environment: Factors affecting future aspirations and school self-efficacy for youth in urban environments. *Child and Adolescent Social Work Journal*, 32(2), 131-141. <https://doi.org/10.1007/s10560-014-0343-7>
- Meece, J. L., Askew, K. J., Agger, C. A., Hutchins, B. C., & Byun, S. Y. (2014). Familial and economic influences on the gender-related educational and occupational aspirations of rural adolescents. *Journal of Educational and Developmental Psychology*, 4(1), 238. <https://doi.org/10.5539/jedp.v4n1p238>
- Meece, J. L., Glienke, B. B., & Burg, S. (2006). Gender and motivation. *Journal of School Psychology*, 44(5), 351-373. <https://doi.org/10.1016/j.jsp.2006.04.004>
- Melby, J. N., Fang, S., Wickrama, K. A. S., Conger, R. D., & Conger, K. J. (2008). Adolescent family experiences and educational attainment during early adulthood. *Developmental Psychology*, 44(6), 1519-1536. <https://doi.org/10.1037/a0013352>
- Mikami, A. Y., Gregory, A., Allen, J. P., Pianta, R. C., & Lun, J. (2011). Effects of a teacher professional development intervention on peer relationships in secondary classrooms. *School Psychology Review*, 40(3), 367-385. <https://doi.org/10.1080/02796015.2011.12087704>
- Mishkind, A. (2014). Overview: State definitions of college and career readiness. *College and Career Readiness and Success Center*. <https://ccrcenter.org/products-resources/overview-state-definitions-college-and-career-readiness>
- Molloy, L. E., Gest, S. D., & Rulison, K. L. (2011). Peer influences on academic motivation: Exploring multiple methods of assessing youths' most "influential" peer relationships. *The Journal of Early Adolescence*, 31(1), 13-40. <https://doi.org/10.1177%2F0272431610384487>
- Moore, K. A., Lippman, L. H., & Ryberg, R. (2015). Improving Outcome Measures Other Than Achievement. *AERA Open*. <https://doi.org/10.1177/2332858415579676>
- Muthén, L.K. and Muthén, B.O. (1998-2017). *Mplus User's Guide*. 8th Edition. Muthén & Muthén.
- Nelson, I. A. (2016). Rural students' social capital in the college search and application process. *Rural Sociology*, 81(2), 249-281. <https://doi.org/10.1111/ruso.12095>
- O'Brien, R. M. (2007). A caution regarding rules of thumb for variance inflation factors. *Quality & Quantity*, 41(5), 673-690. <https://doi.org/10.1007/s11135-006-9018-6>
- Office of Management and Budget (2000). Standards for defining metropolitan and micropolitan statistical areas; Notice. *Federal Register*, 65(249). <https://www.gpo.gov/fdsys/pkg/FR-2000-12-27/pdf/00-32997.pdf>
- Olfson, M., Druss, B. G., & Marcus, S. C. (2015). Trends in mental health care among children and adolescents. *New England Journal of Medicine*, 372(21), 2029-2038. <https://www.nejm.org/doi/full/10.1056/NEJMsa1413512>
- Pascoe, M. C., Hetrick, S. E., & Parker, A. G. (2020). The impact of stress on students in secondary school and higher education. *International Journal of Adolescence and Youth*, 25(1), 104-112. <https://doi.org/10.1080/02673843.2019.1596823>
- Perna, L. W. (2006). Studying college access and choice: A proposed conceptual model. In J. Smart (Ed.), *Higher Education: Handbook of Theory and Research*, pp. 99-157. Springer.
- Perna, L. W., & Titus, M. A. (2005). The relationship between parental involvement as social capital and college enrollment: An examination of

- racial/ethnic group differences. *The Journal of Higher Education*, 76(5), 485-518. <https://doi.org/10.1080/00221546.2005.11772296>
- Prins, E., & Kassab, C. (2017). Rural/non-rural differences among Pennsylvania FAFSA applicants pursuing the same type of postsecondary degree. *Journal of Research in Rural Education*, 32(7), 1-16.
- Schafer, J. L., & Graham, J. W. (2002). Missing data: Our view of the state of the art. *Psychological Methods*, 7(2), 147-177. <https://doi.org/10.1037/1082-989X.7.2.147>
- Sheu, H. B., & Bordon, J. J. (2017). SCCT research in the international context: Empirical evidence, future directions, and practical implications. *Journal of Career Assessment*, 25(1), 58-74. <https://doi.org/10.1177/1069072716657826> <https://doi.org/10.1016/j.jvb.2009.10.015>
- Shim, S. S., Ryan, A. M., & Anderson, C. J. (2008). Achievement goals and achievement during early adolescence: Examining time-varying predictor and outcome variables in growth-curve analysis. *Journal of Educational Psychology*, 100(3), 655-671. <https://doi.org/10.1037/0022-0663.100.3.655>
- Showalter, D., Klein, R., Johnson, J., & Hartman, S. L. (2017). Why Rural Matters 2015-2016: Understanding the changing landscape. *Rural School and Community Trust*. https://www.ruraledu.org/user_uploads/file/WRM-2015-16.pdf
- Shrout, P. E., & Fleiss, J. L. (1979). Intraclass correlations: Uses in assessing rater reliability. *Psychological Bulletin*, 86(2), 420-428. <https://doi.org/10.1037/0033-2909.86.2.420>
- Kindermann, T. (2008). Engagement and disaffection in the classroom: Part of a larger motivational dynamic? *Journal of Educational Psychology*, 100(4), 765-781. <https://doi.org/10.1037/a0012840>
- Taber, K. S. (2018). The use of Cronbach's alpha when developing and reporting research instruments in science education. *Research in Science Education*, 48(6), 1273-1296. <https://doi.org/10.1007/s11165-016-9602-2>
- Tate, K. A., Caperton, W., Kaiser, D., Pruitt, N. T., White, H., & Hall, E. (2015). An exploration of first-generation college students' career development beliefs and experiences. *Journal of Career Development*, 42(4), 294-310. <https://doi.org/10.1177%2F0894845314565025>
- Taylor, R. D., Oberle, E., Durlak, J. A., & Weissberg, R. P. (2017). Promoting positive youth development through school-based social and emotional learning interventions: A meta-analysis of follow-up effects. *Child Development*, 88(4), 1156-1171. <https://doi.org/10.1111/cdev.12864>
- Thapa, A., Cohen, J., Guffey, S. & Higgins-D'Alessandro, A. (2013) A review of school climate research, *Review of Educational Research*, 83(3), 357-385. <https://doi.org/10.3102%2F0034654313483907>
- Thurman, C. B., & Traill, S. K. (2021). The growing role of out-of-school time in driving equitable career exploration and preparation. In T. Akiva & K. Robinson (Eds.), *It Takes an Ecosystem: Understanding the People, Places, and Possibilities of Learning and Development Across Settings*, (pp. 263-278). Information Age Publishing, Inc.
- Tieken, M. C. (2014). *Why rural schools matter*. UNC Press Books.
- Trowler, V. (2010). Student engagement literature review. *The Higher Education Academy*, 11(1), 1-15. https://www.researchgate.net/publication/322342119_Student_Engagement_Literature_Review
- Usher, E. L., Ford, C. J., Li, C. R., & Weidner, B. L. (2019). Sources of math and science self-efficacy in rural Appalachia: A convergent mixed methods study. *Contemporary Educational Psychology*, 57, 32-53. <https://doi.org/10.1016/j.cedpsych.2018.10.003>
- Walburg, V. (2014). Burnout among high school students: A literature review. *Children and Youth Services Review*, 42, 28-33. <https://doi.org/10.1016/j.childyouth.2014.03.020>
- Wentzel, K. R. (2017). Peer relationships, motivation, and academic performance at school. In A. J. Elliot, C. S. Dweck, & D. S. Yeager (Eds.), *Handbook of Competence and Motivation: Theory and Application* (pp. 586-603). The Guilford Press.
- Wigfield, A., Faust, L. T., Cambria, J., & Eccles, J. S. (2019). Motivation in education. In R. M. Ryan (Ed.) *The Oxford Handbook of Human Motivation*, (pp. 463-478). Oxford University Press.
- Williams, L. R., & Anthony, E. K. (2015). A model of positive family and peer relationships on adolescent functioning. *Journal of Child and Family Studies*, 24(3), 658-667. <https://doi.org/10.1007/s10826-013-9876-1>
- Wu, Z., Schimmele, C. M., & Hou, F. (2015). Family structure, academic characteristics, and postsecondary education. *Family Relations*, 64(2), 205-220. <https://doi.org/10.1111/fare.12112>
- Youngblade, L. M., Theokas, C., Schulenberg, J., Curry, L., Huang, I., & Novak, M. (2007). Risk

and promotive factors in families, schools, and communities: A contextual model of positive youth development in adolescence. *Pediatrics*,

119(Supplement_1), S47-S53.
<https://doi.org/10.1542/peds.2006-2089H>

Author:

Peter N. Knox is a postdoctoral fellow in the College of Education & Social Services at the University of Vermont.
Contact: peter.knox@uvm.edu

Suggested Citation:

Knox, P. (2023) Exploring factors associated with academic motivation and college and career readiness of rural adolescents. *The Rural Educator*, 44(3), 34-52.

© 2023. This work is licensed under a CC BY 4.0 license. See <https://creativecommons.org/licenses/by/4.0/>