

A Multi-Agent Framework for Electric Vehicles Charging Power Forecast and Smart Planning of Urban Parking Lots

Manthila Wijesooriya Mudiyansele, Farid Hamzeh Aghdam, S. Mahdi Kazemi-Razi, Kalpesh Chaudhari, *Member, IEEE*, Mousa Marzband, *Senior Member, IEEE*, Augustine Ikpehai, *Member, IEEE* Abdullah Abusorrah, *Senior Member, IEEE* and Gari Harris

Abstract—This paper proposes a novel stochastic agent-based framework to predict the day-ahead charging demand of electric vehicles (EVs) considering key factors including the initial and final state of charge (SOC), the type of the day, traffic conditions, and weather conditions. The accurate forecast of EVs charging demand enables the proposed model to optimally determine the location of common prime urban parking lots (PLs) including residential, offices, food centers, shopping malls, and public parks. By incorporating both macro-level and micro-level parameters, the agents used in this framework provide significant benefits to all stakeholders, including EV owners, PL operators, PL aggregators, and distribution network operators. Further, the path tracing algorithm is employed to find the nearest PL for the EVs and the probabilistic method is applied to evaluate the uncertainties of driving patterns of EV drivers and the weather conditions. The simulation has been carried out in an agent-based modeling software called NETLOGO with the traffic and weather data of the city of Newcastle Upon Tyne, while the IEEE 33 bus system is mapped on the traffic map of the city. The findings reveal that the total charging demand of EVs is significantly higher on a sunny weekday than on a rainy weekday during peak hours, with an increase of over 150kW. Furthermore, on weekdays higher load demand could be seen during the night time as opposed to weekends where the load demand usually increases during the day time.

The Deanship of Scientific Research (DSR) at King Abdulaziz University (KAU), Jeddah, Saudi Arabia has funded this project, under grant no. (RG-11-135-43). In addition, this work was supported from DTE Network+ funded by EPSRC grant reference EP/S032053/1. For the purpose of open access, the author has applied a Creative Commons Attribution (CC BY) licence to any Author Accepted Manuscript version arising from this submission.

M. W. Mudiyansele and S. M. Kazemi-Razi are with the Department of Mathematics, Physics and Electrical Engineering, University of Northumbria, Newcastle, United Kingdom (e-mails: manthila.mudiyansele@northumbria.ac.uk and s.m.kazemi@aut.ac.ir).

F. Hamzeh Aghdam is with the Water, Energy and Environmental Engineering Research Unit, FI-90014 University of Oulu, P.O.Box 4300, Oulu, Finland (e-mail: farid.hamzehaghdam@oulu.fi).

Kalpesh Chaudhari is with Sargent & Lundy, 55 E Monroe St, Chicago, IL 60603. (email: Kalpesh.Chaudhari@SargentLundy.com)

M. Marzband (e-mail: mousa.marzband@northumbria.ac.uk) is with Net Zero Industry Innovation Centre, Campus Masterplan, Teesside University, Middlesbrough TS1 3BA, United Kingdom and also with the center of research excellence in renewable energy and power systems, King Abdulaziz University, Jeddah, Saudi Arabia.

A. Ikpehai (e-mail: a.ikpehai@shu.ac.uk) is with Department of Engineering and Mathematics, Sheffield Hallam University, Sheffield S1 1WB, UK

A. Abusorrah (e-mail: aabusorrah@hotmail.com) is with Renewable Energy and Power Systems Research Group, Center of Research Excellence in Renewable Energy and Power Systems and Department of Electrical and Computer Engineering, Faculty of Engineering, K. A. CARE Energy Research and Innovation Center, King Abdulaziz University, Jeddah 21589, Saudi Arabia

G. Harris (e-mail: G.Harris@tees.ac.uk) is with Net Zero Industry Innovation Centre, Campus Masterplan, Teesside University, Middlesbrough TS1 3BA, United Kingdom.

Index Terms—Electric vehicle, multi-agent framework, parking lot, parking lot aggregator, power forecast, power tracing algorithm, urban planning.

NOMENCLATURE

A. Acronyms

EV	electric vehicle
PL	parking lot
SOC	state of charge
REPL	residential parking lot
OFPL	office parking lot
FOPL	food center parking lot
SHPL	shopping mall parking lot
PUPL	public park parking lot

B. Indices

k	type of EV index, 1 to N_K
n	EV index, 1 to N_N
t	time-step index, 1 to N_T

C. Parameters

a_t	EV acceleration [ms^{-2}]
A_k	vehicle frontal area in type k [m^2]
B_k	battery capacity of the type k [kWh]
C_k^{batt}	EV battery capacity [kWh]
C_k^D	aerodynamic drag coefficient [-]
C_π	Coefficient of rolling resistance [-]
g	gravitational acceleration [ms^{-2}]
m_k	EV mass [kg]
P^{EV}	charging power [kW]
$P^{EV/fast}$	electric motor power [kW]
SOC_i/SOC_f	initial/final EV battery SOC [%]
α	road slope [%]
η_b/η^m	battery/motor efficiency [-]
ρ	air density [$kgms^{-3}$]

D. Decision variables

SOC_{kn}^*	min SOC for path tracing algorithm [%]
F^A	aerodynamic drag force [N]
F^G	gradient resistance force [N]
F^I	initial force [N]
F^R	rolling resistance force [N]
F^{TOT}	total force to the road by the vehicle [N]
P_t^E/P_t^M	electrical/mechanical power [W]
P_{aux}	auxiliary power [W]
SOC_t	EV battery SOC [%]
V_t	speed of the EV at t [ms^{-1}]

I. INTRODUCTION

A. Motivation and aim

At present, electric vehicles (EVs) contribute a significant amount in reducing CO₂ emissions and decrease climate change, while the renewable energy sources (RES) such as wind and solar power decrease the risk of rising price in fossil fuel and dramatic coal depletion [1], [2]. The escalating interest in RESs over fossil fuel has influenced revolutionized changes in EVs, which could mitigate the renewable sources intermittency and benefit the environment in terms of CO₂ emission and air quality. In 2020, around three million new EVs were registered where 1.4 million new registrations were found in Europe, followed by China with 1.2 million registrations [3]. According to the UK government, the transportation sector is the highest greenhouse gas emitting source which is 22% of total greenhouse gas emissions. Therefore, a greater number of leading vehicle manufacturers have been focused on EV technologies and their improvements to satisfy the EVs demand in near future. For example, the UK government has announced to fully convert light-duty vehicles from fossil fuel to battery-electric vehicles by 2030 and heavy-duty vehicles by 2050 [4], [5]. However, the trending demand of EV usage could result in significant stress on the local power distribution system and increase the EV congestion and charging prices, because of inadequate EV parking lots (PLs) [6]. Moreover, a high concentration of EVs charging during peak hours can destabilize the grid system. To address these issues, a peak demand management system can be introduced to encourage EV owners to charge their vehicles during off-peak hours. As per research, more than 95% of a day, EVs are available at parking areas [7]. Therefore, more EVs could gain the opportunity to participate in the power management system by reducing the electrical charge during the on-peak hours.

With the increasing demand for electric vehicles (EVs), the insufficiency of the PL infrastructure is beyond the breaking point. For instance, 2020 has presented a 40% rise in EVs demand in the UK while the PLs have only increased by 24% compared to the previous year. Therefore, the lack of PLs availability would result in bottlenecks when recharging, increase the range anxiety and demotivate the EV drivers, while limiting EV growth. Accordingly, 50%-80% of PLs in the world are installed in residential areas, 15%-25% PLs are installed in office areas and less than 10% of PL could be found in other public locations [8]–[10]. As the energy requirement accelerates with EVs charging demand employed, the necessity of a reliable and adequate power distribution system is essential to accomplish the peak power demand, prevent power failures, and control EV charging cost. Therefore, the optimal planning of EVs charging infrastructure could optimize the amount of supply and demand to solve the energy dilemma. It is essential to consider the charging behaviours of EV drivers when implementing EV charging infrastructure. In this regard, the factors which enhance the efficient usage of the PL infrastructures are important to recognize. In addition, the properly planned PL infrastructure in a city is important to supply the required power demand for EVs in the city. Hence, the UK government has funded a £2.5 billion in grants to implement charging infrastructure

near residential areas, streets, and commercial areas [5], [11]. Therefore, properly planned adequate PL infrastructure has become a global utmost requirement.

B. Literature review

Many studies have been investigated to analyse the grid performance over the EVs charging patterns under several parameters. In literature [12], a probabilistic modeling Queuing theory has been introduced to evaluate the EV charging load behaviour in residential areas. This study focused on the mobility behaviour of EVs from historical data with respect to peak time, vehicle type, type of the day, and average daily mileage. In fact, departure time, arrival time, and distance were generated randomly to identify whether the vehicle is parked or moving. However, it has not considered weather condition, and did not elaborate on any method for EV arrival to PL. In addition, this work is limited to residential areas. Further, a study in [6] has investigated the daily EV charging load profile for demographics and social characteristics (age, gender, and education level), with respect to day type (weekday or weekend), and location by using a spatial-temporal probabilistic model. In particular, the additional factors have been included (such as power consumption rate and charging preference) with the Monte-Carlo algorithm. Nevertheless, this model also has ignored parameters such as state-of-charge (SOC) with vehicle type, weather conditions and driving patterns were limited to home, office and other places which are not specified properly. Moreover, an optimal charging scheduling has been presented in [13] with large-scale EV deployment considering transport system information and grid system operation at the same time. Road length, EV type, vehicle speed and waiting time are taken as transport system information, while load deviation and node voltage are considered as the grid system information. When the battery level is less than 30%, the vehicle is supposed to be scheduled for charging and the schedule is obtained by multi-objective optimization. This is achieved by the weighting the roads considering four factors such as road length, time for passing the road, the ratio of traffic around the PLs and traffic around the charging load. However, this model has not examined some essential factors such as type of the day (weekday or weekend), weather conditions and driving patterns with respect to the location. Moreover, this study is a real-time process and has not assessed any economic impact in the power distribution network. Kandpal *et al* [14], have proposed a day-ahead EV scheduling strategy to mitigate unbalance of the system, by controlling single-phase charging demand of EVs with vehicle to grid option and the charging of the EVs are done as a price-based demand response program. Authors in [15], have considered the mobility of EVs and the stochastic nature EV demand and have formulated the charging scheduling of EVs as a Markov decision process to capture the uncertain EV charging demand in the microgrid of buildings.

Many previous studies have considered parameter variables as deterministic or stochastic. The deterministic method uses average parameter values while the stochastic approach mostly utilizes probabilistic distribution [16], [17]. The number of

methods have been applied to simulate the parameters to find the EV charging demand in the previous studies. In [18], a mathematical model with the spatial and temporal approach is presented to calculate the electric vehicle (EVs) charging demand, while in [19] a BCMP queueing network model is developed to estimate the PEV charging demands in multiple parking lots. Further, probabilistic methods have been utilized in several literature. For instance, studies [16], [17], [20], [21] have applied Support Vector Machines and Monte-Carlo method to obtain the charging demand for EVs. In addition, several methods have been applied in literature to determine the optimal path for EVs to reach PLs. For example, EVs find the optimal route by considering the distance where the nearest PL is selected [22]. However, some studies have considered the minimum time to reach the PL [23], while other studies have considered transport system information (i.e., traffic jam) and grid condition [13]. A root mapping approach used in [24], [25] to reach to the PLs where the vehicle speed is taken as the primary factor and in [26] road gradient, wind speed, vehicle speed and ambient temperature have applied to find the best PL for the EVs. However, this study has applied a novel path tracing algorithm considering the peak time and the distance to the PL when searching for the optimal PL. In [27], optimal placement of EV charging stations has been presented in a radial distribution network considering a road network. Charging demand according to different places such as supermarket, road junctions, have been accounted and the objective is to minimize the energy loss, voltage deviation and the land cost. Authors in [28], [29], have formulated a stochastic mixed integer linear programming model for stand-alone charging stations for EVs using green energy of renewables. The stochastic behaviour of EVs and renewables has been considered. A novel carbon-oriented expansion planning model for EV fast-charging stations is proposed in [28], [29] to determine the optimal locations and size of charging stations. Authors in [30], have proposed a realistic and sustainable framework for optimal planning of the location and capacity of the EVs charging stations and expansion of the electrical distribution system to handle the future load growth.

Agent based models could make individual decisions and interact with other agents. Therefore, in smart traffic control modeling, each vehicle and charging station is considered as separate agents and these agents are accompanied with individual behaviour settings which is more realistic than other methods of simulations [16], [17]. Agent based modeling (ABM) could be discovered in numerous previous power system implementation studies. The authors in [16], [17] have proposed an agent based approach to estimate the EV demand considering each EV driver as a different agent with the characteristics of mobility needs, charging requirements, economical needs. Further, every distribution energy storage (DES) has taken as individual agents in [16], [17] where the dynamic consensus approach is applied to communicate between agents. Moreover, in [31] the renewable energy generation and the load demand have applied as two different agents to predict the energy consumption and the production. Nevertheless, in this study EVs have been defined as an individual agent with the characteristics of different

SOC, battery capacity, mobility pattern etc, while the PLs have been considered as agents with different charging types and charging locations. A cooperative hierarchical multi-agent system has been introduced in [32] to propose an optimal EV charging scheduling strategy to minimize the demand and energy charges and meeting the EVs' energy requirements.

To the best knowledge of the authors, there is not any model which considers the weather condition, traffic condition and the type of the day, at the same time to evaluate the EV drivers' behaviour and predict the EV load profile. Furthermore, the previous works of optimal planning of the PLs location are not based on exact amount of EVs load. Most of the previous studies have considered EVs load demand only in the residential PLs. Accordingly, several gaps have been observed in the literature, which are listed below:

- 1) Numerous studies have examined the behavioural patterns of the EV drivers to predict the day-ahead EVs load profile with respect to different parameters. However, none of them have considered weather condition, type of the day and traffic condition which leads to less accurate predicted EVs load. Also, they cannot produce real load of each city.
- 2) Most of the previous works have considered only one or two types of PLs including residential and commercial ones. Therefore, they cannot model the total load of a city.
- 3) Many of the previous studies have not determined the optimal location for PLs by the actual data such as real city transport data and well-predicted load profile of EVs charging pattern. This results in non-optimal location of PLs which increases operational expenses, congestion, voltage deviation, as well as EV drivers dissatisfaction.

C. Research contributions

The factors influencing the EVs charging demand are driver behaviour, location of PLs, electricity pricing and etc. However, most of the reviewed literature has ignored the factors related to the social characteristics of EV drivers, and some models have not considered the economic elements. Therefore, it is essential to account for charging behaviours of EV drivers when implementing EV charging infrastructure. In this regard, the factors which enhance the efficient usage of the PL infrastructures are important to be recognized. Accordingly, this study presents a stochastic agent-based framework for observing the EVs charging behaviour to accurately predict the electricity demand in all types of PLs in presence of different EVs and effective factors. The agents enable the proposed framework to model micro- and macro-level parameters of all stakeholders including EVs, PL aggregators, PL operators, and distribution network operators are considered simultaneously as a community and consider their mutual impacts. Moreover, it identifies the optimal location of PLs in the city, while ensuring maximum utilization of the PL infrastructure. With respect to the literature, following major research contributions (RCs) are highlighted in the proposed framework.

- 1) **RC1:** Proposing a novel agent-based framework to predict the EVs charging demand considering the key effective factors including type of day, weather conditions,

as well as traffic condition which enables the proposed model to evaluate the driving behaviour of the EV drivers and predict the EV load demand exactly for city based on its own climate/ traffic data.

- 2) **RC2**: Considering various PLs including REPL, OFPL, FOPL, SHPL, and PUPL to predict the total EVs load and the individual EV load profile in each of them. Each PL contains one of the charging strategies including fast and slow. The complex interdependence system between micro- and macro-level parameters is captured in the process of modeling of queuing, PLs path finding and tracing algorithms for EVs. To do this, path tracing algorithm is used to find the nearest PL for each EV in each point of the city.
- 3) **RC3**: Determining the optimal locations for PLs using accurate predicted load profile of all types of PLs aiming at cost reduction of stakeholders and maximum satisfaction of EV drivers. Also, the electricity network of city is mapped on its traffic map which allows accomplishing the preliminary power system analysis including an AC power flow. Thus, the optimal locations are also determined in a way that considers the grid operation, identifies the excess loads, and minimizes the voltage deviation and congestion.

D. Comparison

Considering the presented contribution in this study, Table I provides the in-depth comparison between previous studies and the proposed framework. As it can be seen, this study has covered the research gap in the reviewed literature such as weather condition, peak hours, day type, various types of PLs, charging methods, and day-ahead market. It can be seen that this paper covers a comprehensive study or the smart planning of urban PLs.

E. Paper Structure

The rest of paper is organized as follows: Section II presents the proposed method and describes how the path tracing algorithm finds the nearest PL. Also, the software that is used to implement the proposed multi-agent model is introduced. The proposed formulation of each agent and the framework parameters are explained in Section III. In Section IV, the data of a city is used for a series of studies to show the validation of the proposed framework. Section V concludes the paper.

II. PROPOSED IDEA

A. The structure of the proposed framework

The proposed framework for decentralized power management utilizes a multi-agent system, where each stakeholder is represented by an agent as shown in Fig. 1.

The distribution network operator (**Agent 1**) performs as a wholesale day-ahead market where the electricity is generated and sold to PL aggregator. It includes weather/ traffic data of the city and different types of day. Agent 1 also models roads and traffic lights to provide a real-time environment and enhance the accuracy of the end results. PL aggregator (**Agent 2**) operates as energy service provider, purchasing

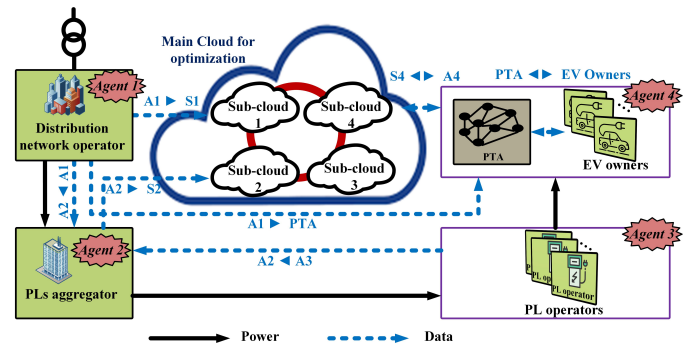

Fig. 1. The agent-based structure of the proposed framework.

electricity from Agent 1 and supplying it to PL operators while proposing energy prices to maximize profits. PL operators (**Agent 3**) participate this framework as energy servers to EVs, with the ability to define the energy prices for EVs to maximize their profit. EVs owners (**Agent 4**) benefit from this framework by reaching the destination via the shortest path while saving time and maximizing the EV efficiency. Agent 4 also enables the modeling of EVs based on their charging characteristics, mobility patterns including private and commercial ones, and type. In fact, a central cloud has been introduced to store, exchange, and process data where each agent has an individual sub-cloud for its computations. These sub clouds exchange data with each other to predict the total loads and the individual loads of each stakeholder and determine the optimal location of PLs. Agent 2 collects information including the PLs locations, current total load demand, the current number of EVs, and the total number of PLs from agent 3 (i.e., $A3 \rightarrow A2$). On the other hand, weather information (including sunny and rainy) and the type of day (weekday or weekend) is provided by Agent 1 (i.e., $A1 \rightarrow S1$). The calculations of the profit of Agent 3 are implemented in Sub-cloud 3. Furthermore, when a EV driver wants to find a PL to charge the EV, personalized trip advisor (PTA) receives the traffic data from agent 1 while obtaining the initial SOC, departure time, current speed and current location of EV from EV drivers. Thereafter, PTA determines the availability of the nearest PL for the EV driver (Section II-B).

The EV charging behaviour in each PL is varying with several interdependent parameters which belong to stakeholders, as shown in Fig. 2. Three of these parameters are weather conditions, the type of the day, and traffic conditions (**RC1**). The proposed framework models the interactions of these parameters which makes it able to consider the mutual impact of all stakeholders. The micro-level parameters are dedicated to an individual EV, while macro-level parameters are dealing with a group of EVs. Modeling the mutual impact enables the proposed model to predict accurately the charging demand of EVs based on the behaviour of EV drivers, PL operators, and PL aggregators. The interdependence system is captured in the process of modeling of queuing, PL path finding and PTA for EVs.

The interactions between agents that allow modeling the connections between macro- and micro-mobility patterns make

TABLE I
COMPARISON OF THE LITERATURE AND THIS STUDY.

Ref.	Weather condition	Peak hours	Day type	PL	Charging method	Day-ahead market	Management strategy	EV Type	Stakeholders
[22]	×	✓	✓	REPL	Slow	×	Centralized	Not specified	EV owners, National Grid
[6]	×	✓	✓	REPL	Fast/ Slow	×	Centralized	Not specified	EV owners, National Grid
[13]	×	✓	×	-	Fast	×	Centralized	Not specified	EV owners, National Grid
[18]	×	✓	×	-	Fast	×	Decentralized	PHEV 33 compact sedan	National Grid, Energy providers
[19]	×	✓	✓	REPL	Fast	×	Centralized	Not specified	PL operators, EV drivers
[16], [17]	×	✓	✓	REPL, OFPL	Slow	×	Centralized (agent-based)	Not specified	Electricity market, Electricity retailers
[20]	×	✓	×	-	Fast/ Slow	×	Decentralized	Not specified	EV aggregators, PL owners, EV drivers
[21]	×	×	✓	-	Not specified	✓	Not specified	Not specified	EV owners, National Grid
[24]	×	✓	×	-	Fast/ Slow	×	Centralized	Daimler electric Smart	EV owners, National Grid
[25]	×	×	×	REPL	Fast/ Slow	✓	Centralized	Nissan leaf, Tesla Model S BMW i3, Fiat 500E Chevrolet Spark, Ford Focus VW e-Golf, Mercedes B-Class Kia Soul, Mitsubishi iMi Honda Fit, BMW Active E	Power grid, Aggregator, EV drivers
[26]	×	×	×	REPL	Slow	✓	Centralized	Not specified	EV user, PL operators, system operators
[23]	×	✓	✓	REPL, FOPL, SHPL	Fast/ Slow	×	Not specified	Not specified	EV owners, National Grid
[16], [17]	×	✓	×	-	Not specified	×	agent-based	Not specified	EV owners, National Grid
[16], [17]	×	×	×	-	Not specified	×	agent-based	Not specified	EV owners, National Grid
[16], [17]	×	✓	✓	REPL, OFPL, FOPL, SHPL	Fast/ Slow	×	Decentralized (agent-based)	BMW i3, Nissan Leaf, and Kia Soul	EV aggregators, EV owners
This study	✓	✓	✓	REPL, OFPL, FOPL, SHPL, PUPL	Fast/ Slow	✓	Decentralized (agent-based)	Volkswagen ID 3, Hyundai Ioniq 5 Kia e-Niro	Distribution network operator, PL aggregators PL operators, EV owners

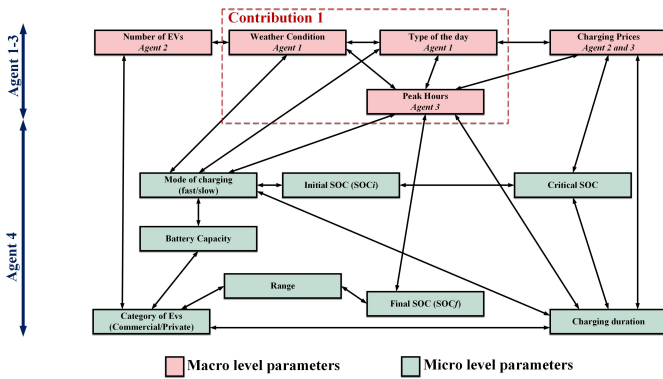

Fig. 2. The interaction of parameters used in the proposed framework.

the proposed framework to be a hybrid modeling system and allow to model EVs charging demand behaviour accurately.

Therefore, the proposed framework allows considering the interactions of weather conditions, traffic conditions, the type of day and SOC with other parameters as shown in Fig. 3 to analyze how they affect charging demand of individual EVs (micro-level) or total EVs (macro-level). Moreover, their effects in macro-level can lead to more optimal location of PLs. Modeling micro- and macro-level parameters allows considering driver's behaviours/preferences in predicting EVs charging demand that leads to accurate real results.

The system parameters are the State of Charge (SOC), the type of vehicle (commercial or private), type of the day (week-day or weekend), mode of charging (fast or slow charging), charging location (residential, office, public park, shopping mall or restaurant), weather condition (rainy or sunny day), and local traffic conditions to define the peak hours throughout the day. These all effective parameters allow predicting the charging demand accurately.

B. The flowchart of the proposed framework

The proposed framework contains two non-linear optimizations, as depicted in Fig. 3. The first optimization is carried out using NETLOGO, which predicts the total load demand (i.e. the load of PL aggregator) and the individual load of each PL over the next 24 hours. The optimization process also aims to maximize the profit of all stakeholders, while

taking into account the preferences of EV drivers. The second optimization is implemented in MATLAB to determine the optimal location of PLs based on the predicted loads in the first optimization while ensuring maximum utilization of the PL infrastructure. Agent 1 requires weather data and the characteristics of the electricity network of the selected city. It also needs access to local traffic data to find the congestion areas in peak hours and the driving patterns. Agent 3 requires information about the characteristics of fast and slow charging equipment and the type of PLs. Ultimately, Agent 4 needs the characteristics of the types (including private and commercial) of EVs and the EV driver's behaviour.

Agent 1 sends the weather data and the type of the day to sub-cloud 1 and sends the electricity price to PL aggregator (RC1). PL aggregator offers the price to each PL operator in order to maximize their benefits. Agent 2 models different types of PLs including REPL, OFPL, FOPL, SHPL, and PUPL (RC2), and charging strategies including fast and slow charging for each type of PL. Afterwards, each PL operator determines the electricity price for EVs that want to be charged by its chargers. EVs move towards their destinations. When the SOC of an EV becomes less than SOC_{kn} , it starts searching the nearest PL by PTA. If the nearest PL is fully occupied by the time EV is reached, then EV moves to the next nearest available PL. However, if the PL is available, EV can wait in the queue. EVs follow the queuing theory with the first come first out (FIFO) method when waiting in the queue. Therefore, each PL sends information about its power demand, number of EVs, and PL location to the PL aggregator. Thus, the EVs charging load is predicted through the parallel operation of agents in NETLOGO and is sent to MATLAB. Agent 1 maps the traffic map to the electricity network. Afterwards, Matpower determines the optimal location of PLs aiming at a minimum price for EVs, minimum charging load, maximum EV driver's satisfaction, as well as the minimum force given to the power grid. The optimal locations are selected near to main streets, and the AC power flow performed through the planning to identify the excess loads and avoid voltage deviation and congestion in the grid.

The process of PTA applied in Block A of Fig. 3 is shown in Algorithm 1. First, the location, SOC, speed, and departure time of the EV is received from the EV owner. PTA also receives traffic data from Agent 1. Using this information,

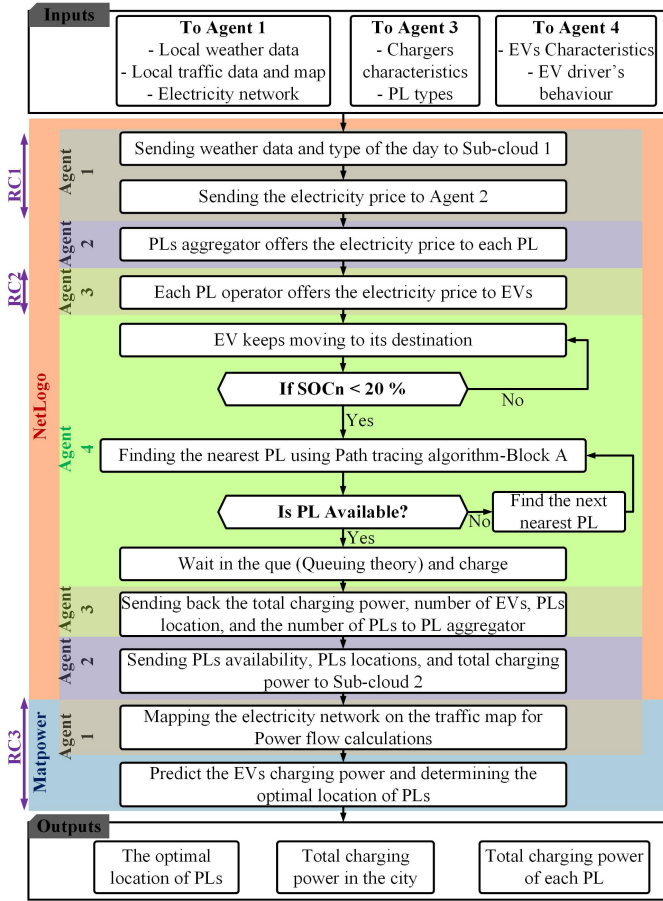

Fig. 3. Flowchart of the proposed framework.

PTA computes the distance of EV to each PL and sorts PL from the nearest to the farthest. Afterwards, it calculates the estimated arrival time of EV for the nearest PL. Agent 4 uses the estimated arrival time and the initial SOC of EV, as well as the availability status of PLs which is received from Agent 2, and determines whether the PL is available or not.

Algorithm 1 Flowchart of PTA (Block A of Fig. 3).

- 1: **get** initial SOC, EV departure time, EV current location, and EV current speed; ▷ from EV owner
- 2: **get** traffic data; ▷ from Agent 1
- 3: **calculate** the distance of EV to each PL;
- 4: **sort** PLs from the nearest to the farthest;
- 5: **calculate** the arrival time of EV for this PL;
- 6: **send** the arrival time; ▷ to sub-cloud 4
- 7: **receive** the availability status of the PL; ▷ from sub-cloud 4

III. PROBLEM FORMULATION

A. EVs structure (Agent 4)

1) *Mechanical and Electrical power:* The average energy consumption of EVs can be defined by the road loads as shown by Eq. (1) [33]. FTOT is the total force, FI is the initial force, FR is the rolling resistance, FG is the gradient resistance and FA is the aerodynamic drag.

$$F_{TOT} = F_I + F_R + F_G + F_A, \quad \forall_{tb} \quad (1)$$

Initial force is given by EV mass and its acceleration during minute t, in k type of EV (Eq. (2)).

$$F_I = m_k \cdot \alpha_t, \quad \forall_{tb} \quad (2)$$

Rolling resistance is the force occurred in the tires when contacting the road. The equation for the rolling resistance is given in Eq. (3). Where C_π is the coefficient of rolling resistance, α is road slope, m_k is EV mass of k type EV, and g is the gravitational acceleration.

$$F_R = C_\pi \cdot m_k \cdot g \cdot \cos \alpha, \quad \forall_{tb} \quad (3)$$

Gradient resistance is applied when the EV is moving upward or downward slope (Eq. (4)).

$$F_G = m_k \cdot g \cdot \sin \alpha, \quad \forall_{tb} \quad (4)$$

Aerodynamic grad occurred due to the viscous resistance present on the vehicle. This is mainly depending on the shape of the vehicle. The formula for the aerodynamic drag force is expressed as in Eq. (5). Where ρ is the air density, C_{dk} air drag coefficient and A_k is vehicle frontal area in the k type of EV. V_t is the speed of the EV at time t.

$$F_A = 1/2 \rho C_{dk} A_k V_t^2, \quad \forall_{tb} \quad (5)$$

The average total power or mechanical power (Pm_t^{ev}) in Watt could be derived from the product of vehicle speed and the total road resistance. However, in this model, the road slop has been ignored.

$$Pm_t^{ev} = F_{TOT} V_t, \quad \forall_{tb} \quad (6)$$

$$Pm_t^{ev} = m_k V_t [a_t + C_\pi g \cos \alpha + g \sin \alpha] + 1/2 \rho C_{dk} A_k V_t^3, \quad \forall_{tb} \quad (7)$$

Eq. (8) is utilized to convert the mechanical power to electrical power. The auxiliary power could be considered as common EV electrical components (auxiliary loads) such as heating and cooling. Where η_m is the motor efficiency and the P_{aux} is the auxiliary power.

$$Pe_t^{ev} = \frac{Pm_t^{ev}}{\eta_m} + P_{aux}, \quad \forall_{tb} \quad (8)$$

2) *SOC of EVs:* The SOC at a specific time depends on the initial SOC and the battery capacity. According to Coulomb Counting method [20] the SOC could be expressed as shown in Eq. (9). Eq. (9) could be rewritten as following Eq. (10). Where η_b is the battery efficiency and B_k is the battery capacity of the k type of EVs.

$$SOC_t = SOC_{t-1} + \int_0^t \frac{I}{C_{bat,k}} dt, \quad \forall_{tb} \quad (9)$$

$$SOC_t = SOC_{t-1} - \frac{Pe_t^{ev}}{\eta_b \times B_k \times 60}, \quad \forall_{tb} \quad (10)$$

The relationship between the initial SOC (SOC_i) and the final SOC (SOC_f) is given in Eq. 11.

$$SOC_i = SOC_f - \sum_t \Delta SOC_{ev}^t, \quad \forall_{tb} \quad (11)$$

B. Charging types (Agent 3)

DC charging is faster than the AC charging. Therefore, EV charges in the simulation are DC type along with fast and slow charging functionalities. EV is able to select the method of charging according to the current SOC, remaining time, and the distance. Further, the charging type could affect the EV charging time.

C. Environmental parameters (Agent 1)

1) *Peak hours*: The peak hours change mainly due to three factors including the PL location, the type of day, and the weather condition. In the simulation, charging behaviour in five different PLs have applied to observe the EV load.

2) *The type of Day*: The EV load profile depends on the type of day including weekdays and weekends. For instance, a higher number of EVs charge the batteries during weekdays at offices, while on weekends more EVs at public parks and shopping malls during the daytime.

3) *Weather conditions*: The EV load demand is directly varying with the weather condition. For example, the UK follows four seasons annually, and more sunny days are available during summer and rainy days in winter. Literature explains that people tempt to go outside during sunny days compared to rainy days [7]. In the simulation, the weather condition has been introduced as 10 levels, where level 10 represents the 100% sunny day and level 1 represents 100% rainy day. The weather level could be changed according to the forecasted weather report. For instance, the weather level sets to be 6, when the selected day is 60% sunny and 40% rainy.

In addition, the weather condition fluctuates with respect to the Gaussian normal distribution between 50% to 100% among the total number of EVs in the simulation model as shown in Eq. (12). In other words, the model assumes that at least half of the EVs will experience a particular weather condition, and up to all of the EVs may experience that same condition. Further, this allows capturing the range of weather conditions that the majority of the EVs are likely to experience, while still allowing for some variability in the weather conditions across the EVs.

4) *Number of EVs*: In this model, two types of EVs were considered such as commercial and private vehicles which have different driving behaviours. The number of EVs mainly depends on the weather condition, type of the day, and the peak hours. For instance, a higher number of EVs are available at the PLs during the peak hours and it could result in queues near the PLs because of the limited number of PLs. Therefore, considering the number of EVs is essential when planning to install the PLs in a specific area.

5) *Charging prices*: The charging prices could massively depend on peak hours and the type of day. For example, higher charging prices could expect on a busy day during peak hours. Consequently, the charging price will affect the charging duration of each EV and the final SOC (*SOC_f*) as the EVs drivers tempt to charge only the most essential amount for their journey, if the charging prices are high.

$$P(x) = \frac{1}{\sqrt{2\pi}\sigma^2} e^{-\frac{(x-\mu)^2}{2\sigma^2}}, \quad \forall tb \quad (12)$$

The simulation model is implemented to select the variance and the mean from 1 to 10 on the GUI (Graphical User Interface) according to the location data in the selected area. When the weather condition is at level 10, all the vehicles are operating, and it is decreased by 5% when the weather condition steps down by a single level, up to level 1. In this model, the mean value is defined as $\mu=8$, and variance is applied as $\sigma=2$.

6) *Micro-level parameters*: Category of EVs (commercial/private)

The total number of EVs have been divided into two categories as commercial and private. In this paper, electric taxis are accounted as commercial vehicles, and personal vehicles have been considered as private vehicles. In the simulation platform, it has considered 50% as private vehicles and 50% as commercial vehicles. Moreover, the EV category could vary the EV range, battery capacity, and the charging duration.

7) *Battery capacity and range*: The battery capacity of the EV decides the driving range of the EV and the capacities of the EV batteries are changed according to the EV model. Higher battery capacities are able to drive long distances, which means vehicles with a higher range.

8) *Mode of charging (fast/slow)*: The charging mode of EVs has been categorized as fast and slow charging. In this study, EVs choose the mode of charging according to their preference. For instance, EVs drivers could select fast charging to save charging time during peak hours. Consequently, the mode of charging depends on the type of day and the weather condition. In this study, the slow charging is considered as 6.6kW and the fast charging (DC fast charging) has been accounted as 50kW capacity.

Agent 3 must be provided with fast and slow charging information and the type of PLs. For instance, rate of charging, AC or DC types, current and voltage information.

Proposing a novel agent-based framework to predict the EVs charging demand considering the key effective factors including the type of day, weather conditions, as well as traffic conditions which influence the driving behaviour of the EV drivers impacting the EV load demand. (To map the city in the model. The model of the city to draw in the simulation platform with roads, traffic lights, and parking areas to provide a real-time environment and optimize the accuracy of the end results.

The EV charging behaviour in each location is varying with several interdependent factors such as the percentage of sunny or rainy conditions on a weekday or weekend at peak hours or off-peak hours.

The above-mentioned parameters provide a complex interdependence system, which is captured in the process of modeling of queuing, PL path finding and tracing algorithms for EVs. Therefore, the Path tracing algorithm is used in the proposed framework to find the nearest PL for EV in each point of the city. (different charging strategies including fast and slow charging in each type of PL).

Moreover, agent 4 makes it possible to model EVs based on their charging characteristics, mobility pattern and type. The proposed framework has taken two types of EVs as private and commercial (taxi) vehicles with different behaviours to model real existing behaviours. It is assumed that the driving behaviour of conventional vehicles is similar to the driving behaviour of EVs. Furthermore, three main types of EVs have been applied in the framework to model characteristics of the most popular existing EVs in the real networks. In addition, Agent 4 models the SOC of EVs.

Agent 3 models the different types of PLs including REPL, OFPL, FOPL, SHPL, and PUPL and different charging

TABLE II
SYSTEM PARAMETERS

System parameters	Quantity
P_{aux} [kW]	700
η_m [%]	95
η_b [%]	90
Number of EVs [-]	400
g [$m.s^{-2}$]	9.8~1
α [-]	0

TABLE III
EV AND BATTERY SPECIFICATIONS

EV Type [k]	m_k [kg]	B_k [kWh]	C_{dk} [-]	A_k [m^2]	P^{EV} [kW]		Range [km]
					Fast	Slow	
Hyundai Ioniq 5	2540	58.2	0.288	2.80	50	10	350
Volkswagen ID 3	1934	58.0	0.267	2.36	100	11	375
Kia e-Niro	1812	40.0	0.290	2.56	77	9	270

strategies (including fast and slow charging) while Agent 1 considers different types of day (including weekday and weekend), different weather conditions (including sunny and rainy), and local traffic condition (to define peak hours). Agent 1 also models roads and traffic lights to provide a real-time environment and enhance the accuracy of the end results.

IV. CASE STUDY SIMULATION

A. The characteristics of the network used for assessing the proposed framework

The values of EV parameters in agent 4 are presented in Table II.

To define the optimal location of PLs, the proposed model maps the traffic map of the city to the IEEE-33 bus system. Determining the optimal locations for PLs is done using accurately predicted load profile of all types of PLs.

The maximum number of EVs have set to 500 in the simulation and it could be changed according to the selected date in GUI. EVs are categorised into two types such as private and commercial where each type follows individual driving patterns and all the EVs follow the traffic light rules in the developed model. The peak time of each location is predefined with respect to the Newcastle city previous data. Level 7 of the driver's experience is taken and it is not changed.

The minimum SOC that EV uses to start finding the nearest PL (SOC_{kn}) is 20% of its battery capacity. The penetration of private and commercial EVs is 50% among all 500 EVs considered in this assessment. In the simulation, purple vehicles are indicated as private vehicles and commercial vehicles represent in orange. It is assumed that the driving behaviour of conventional vehicles is similar to the driving behaviour of EVs. Further, three main types of EVs have been applied in the framework including Volkswagen ID 3, Hyundai Ioniq 5 and Kia e-Niro. The EV and battery specifications are presented in Table III.

The data of Newcastle Upon Tyne in the UK is used in this Section to verify the proposed model. According to statistics in Newcastle, the peak time in a typical weekday of each PL is presented in Table IV. The proposed model runs for 24 hours and obtains the results.

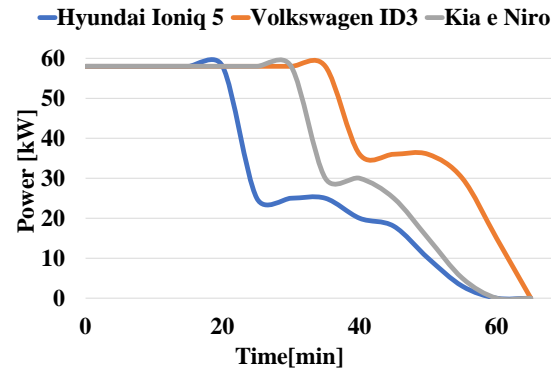

(a) Fast charging

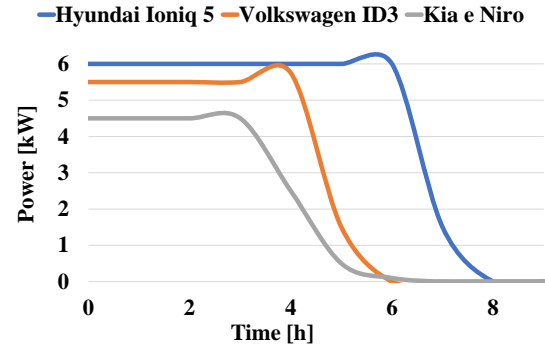

(b) Slow charging

Fig. 4. The charging characteristics of EV batteries.

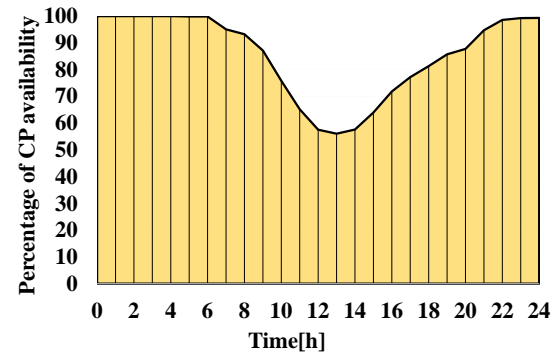

Fig. 5. Car park availability percentage, Newcastle [34].

B. Simulation Platform of NETLOGO

As stated in Section II-B, the first optimization of the proposed framework is implemented by NETLOGO 5.3.1 software [35] to predict the day-ahead EV load demand by applying the mentioned parameters in Fig. 2 with EV drivers' behaviour.

NETLOGO is a programming language which applies to agent-based models. In this software, it is possible to receive instructions and operate independently for a large number of agents at the same time (i.e. parallel processing). The blocks of the software could be formed as turtles which are moving blocks such as vehicles, patches that are steady blocks such as home and offices, links, and observers [31].

The basic agent-based model used for EVs and PLs in NETLOGO in the proposed framework has been extended from [36].

NETLOGO allows modeling complex interactions of all

TABLE IV
PEAK TIME OF DIFFERENT PLS IN A TYPICAL WEEK DAY.

PL location	Morning	Afternoon	Evening
Offices (OFPL)	07:00-09:00	N/A	17:00-19:00
Residential (RIPL)	N/A	N/A	20:00-22:00
Shopping malls (SHPL)	N/A	11:00-14:00	N/A
Restaurants (RTPL)	N/A	12:00-14:00	18:00- 20:00
Public parks (PUPL)	N/A	16:00-18:00	N/A

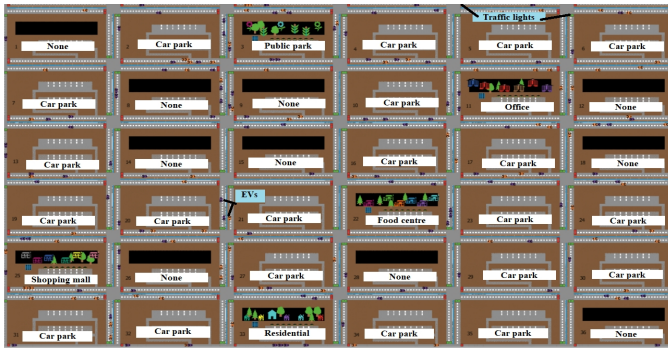

Fig. 6. Types of PLs implemented in NETLOGO (agent 3).

parameters shown in Fig. 2 that enables to consider the mutual impact of all stakeholders. NETLOGO allows EVs as a single block in the simulation platform which could make decisions individually based on their own aims that shows the microscopic interactions. For example, if the SOC of the EV falls below the threshold amount, it starts searching for the nearest PL. But their behaviour is also affected by the behaviour of other EV drives that which can lead to macroscopic interactions. For example, if PL is occupied, EV must search for another PL or stay in the queue.

The simulation platform makes it possible to model the city with roads, traffic lights, and parking areas in Agent 1 to provide a real environment and increase the accuracy of the end results. Traffic lights are defined as red and green to stop and move the cars, respectively. The city in the simulation is mapped with 36 similar-sized blocks with parking areas in agent 3 and the blocks can be changed according to the corresponding map of the city. Each of the blocks can be changed as REPL, OFPL, FOPL, SHPL, PUPL, carpark, or none, as shown in Fig. 6. In the model, all the areas are accompanied with eight charging slots except the locations such as carpark and none. It is possible to define the number of EVs and change the proportion of private vehicles to commercial ones according to the city data in Agent 4. Each type of EV follows individual driving patterns and all of them follow the traffic light rules. The nearest PL which is determined by PTA activated in NETLOGO is selected by minimum distance to the EV when it starts to search for a PL. Initially, the patch where the EV is located is defined. Thereafter, the distance to every available PL is determined individually by counting the number of patches on the roads from the EV location, where each patch (square) in the simulation platform is defined as a kilometer in real life. Finally, all the path distances are sorted in ascending order, where the closest PL will be selected as the first choice.

Fig. 7 shows that the type of the day could be weekday or

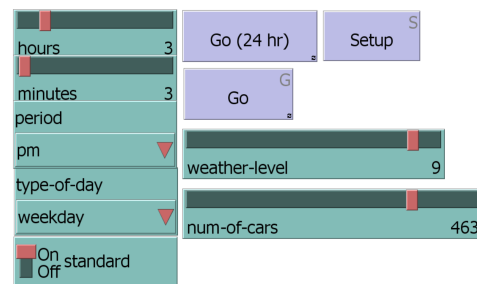

Fig. 7. Essential inputs in the simulation platform.

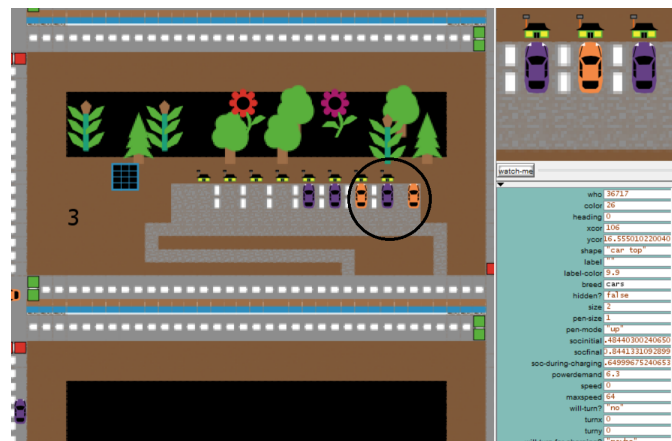

Fig. 8. Available characteristics of EVs charging in PL 3.

weekend, and the weather level can vary from level 1 to level 10. The level 7 of driver's experience is taken and it is not changed. Moreover, electricity prices can be set at individual PLs. NetLoge makes it possible to monitor EV characteristics. Fig. 8 shows the characteristics of EVs in PL 3.

C. Grid mapping

The proposed model was mapped into the standard IEEE-33 bus system to enhance the practical applicability. The IEEE-33 bus system is mapped with the traffic map of Newcastle upon Tyne.

Further, it is assumed that the point of common coupling (PCC) is located in Bus 1 and the maximum amount of real power exchange is 1MW. In fact, it is assumed that office PL is located at bus 28, public park PL is located at bus 20, shopping mall PL is placed at bus 5, restaurant PL is placed in bus 9 and the residential PLs are located at buses 31 and 24, respectively. Fig. 9 represents the optimal location of PLs in IEEE 33 bus system.

To analyze the effect of the proposed model in EVs charging demand and the optimal location of PLs, four case studies (PLs) is considered as follows:

- 1) **CS1:** Find the total load demand and individual load demand in all five areas when, Type of the day= weekday, Type of the weather= sunny day (weather level= 9), (average or typical sunny weekday);
- 2) **CS2:** Find the total load demand and individual load demand in all five areas when, Type of the day =

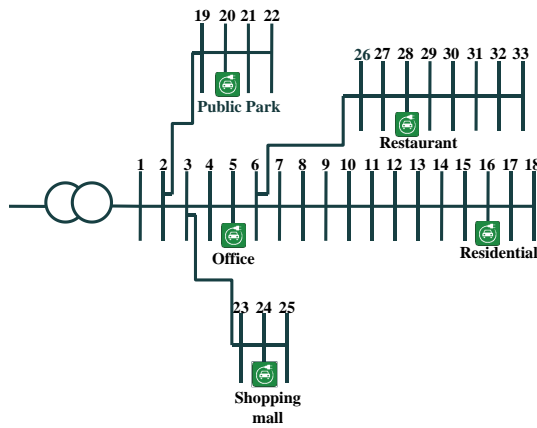

Fig. 9. Current locations of PLs in IEEE-33 bus system coordinated with traffic map of Newcastle upon Tyne.

weekend, Type of the weather= sunny day (weather level= 9);

- 3) **CS3**: Find the total load demand and individual load demand in all five areas when, Type of the day = weekday, Type of the weather = rainy day (weather level= 4);
- 4) **CS4**: Find the total load demand and individual load demand in all five areas when, Type of the day= weekend, Type of the weather= rainy day (weather level= 4).

D. Probabilistic parameters

Table V shows the probabilistic parameters taken in each case study to show peak hours for PLs. μ is defined as the mean and the variance is presented as σ .

E. Results assessment

1) *Total EV load demand (agent 4, agent 2 or agent 3)*: The results verify the EV total charging demand hugely depends on the weather conditions, peak hours, and the type of day.

The total EV load demand in **CS1** in the city is shown in Fig. 10(a). According to the figure, the peak load demand could be expected at night around 20:00-22:00 which is around 400kW. This is obvious because, more people tempt to stay at home and charge their EVs at night compared to the daytime. Further, the daytime peak has spread from 10:00-16:00, where the EVs load is approximately 290kW, as peaks in offices, restaurants, public parks, and shopping malls layout during this time period. In addition, a significant rise is illustrated after 16:00 from around 130kW to 400kW within 2 hours, because the EV load demands in offices, shopping malls, public parks and restaurants are beginning to rise after 16:00 as many EV gather around these areas by that time. On the other hand, EV total load demand is reducing rapidly after 22:00 in the night-time as restaurants, offices, shopping malls, and public parks are close by that time and many residential prefer to sleep rather than charging their EVs. Fig. 10(b) illustrates the total EV load demand in **CS2**. As per the figure, more EVs are tempted to charge the batteries during daytime compared to night-time, confirming that many people in the city would

prefer to go outside on a sunny weekend. Moreover, the total EV load demand has been accelerated notably from 07:00-10:00 in the morning, which is from around 100kW to 500kW as the morning peaks in public park, residential could be seen and the EV loads in shopping mall and restaurant begin to increase during this time. The average peak load demand is approximately 450kW which is distributed for 3 hours after 12:00 due to the peaks of shopping mall, restaurant and public parks are spread over these hours. In addition, the night-time total EV load demand is around 300kW, and another peak is presented from 19:00-22:00. This is because the night-time peak in residential area is presented during these hours. Thereafter, a significant downward trend could be seen from 22:00-00:00 as all the office, shopping mall, restaurants and public park are closed, and people temp to sleep at by that time. The EV total load demand in **CS3** is presented in Fig. 10(c). With respect to the figure, the peak EV demand is expected during daytime compared to the night hours. It is possible to assume that more people tempt to stay at home and charge. There are EVs during rainy days rather than going outside. Further, the peak demand is around 350kW presented from 12:00-14:00 in the daytime, while the night-time peak is about 250kW from 20:00-22:00. This is because the day-time peak and the night-time peak in residential area is laid down over these hours, and the EV load demand in office, shopping mall, restaurant, and public park is comparatively lower than the residential EV load demand. However, there is less EV demand that could be seen during the early morning hours which is exactly after 00:00 to 06:00 as shopping mall, restaurant, public park and office areas are closed and people in residential are sleeping during this time. Further, an upward trend is illustrated from 07:00-11:00 due to the EV load increment in residential and office areas, and a downward trend could be seen after 15:00 including fluctuations because of the EV load depletion of office, restaurants and public park. The EV total load demand in **CS4** is shown in Fig. 10(d). With regards to the figure, more EV load could be seen during the afternoon and night-time compared to day hours as more people temp to stay at homes or drive back home before evening, because of the rain. Further, the afternoon peak is presented from 14:00-17:00 (150kW) as the EV loads in shopping mall, office and restaurant has been increased compared to the other load values over the day, while the night-time peak is illustrated over 19:00-21:00 (200kW) which was hugely dependent on the EV load in the residential area. The load demand has decreased after 22:00-00:00 from nearly 175kW to 0kW due to the people's sleep time in residential and other areas are not open during that time. Another notable reduction could be seen from 13:00-14:00 around 200kW to 100kW because of the significant EV load demand depletion of shopping mall and restaurant areas, as many people prefer to have lunch before 13:00 in the UK. Nevertheless, an upward trend could be seen from morning to 13:00 as people temp to start their works in the morning and drive back to homes as soon as possible because of the bad weather condition, and thereafter the EV load remains straight while maintaining the average of around 200kW from 14:00-22:00.

According to Fig. 10, it is confirmed that the peak EV load

TABLE V
PROBABILISTIC PARAMETERS.

	CS1	CS2	CS3	CS4
Offices (OFPL)	$\mu=9, \sigma=2, \mu=17, \sigma=2$	$\mu=9, \sigma=2, \mu=17, \sigma=2$	$\mu=9, \sigma=2$	$\mu=9, \sigma=2$
Residentials (RIPL)	$\mu=6, \sigma=2, \mu=22, \sigma=2$	$\mu=12, \sigma=4, \mu=22, \sigma=2$	$\mu=10, \sigma=2, \mu=21, \sigma=2$	$\mu=12, \sigma=2, \mu=22, \sigma=2$
Shopping malls (SHPL)	$\mu=12, \sigma=4, \mu=20, \sigma=2$	$\mu=12, \sigma=2, \mu=20, \sigma=2$	$\mu=12, \sigma=3$	$\mu=12, \sigma=2$
Restaurants (RTPL)	$\mu=12, \sigma=2, \mu=19, \sigma=2$	$\mu=12, \sigma=2, \mu=19, \sigma=2$	$\mu=12, \sigma=2, \mu=17, \sigma=2$	$\mu=12, \sigma=2$
Public parks (PUPL)	$\mu=20, \sigma=2$	$\mu=17, \sigma=2$	$\mu=10, \sigma=2, \mu=17, \sigma=2$	$\mu=10, \sigma=2$

demand on rainy days is slightly less than the peak EV load demand on sunny days. Further, more demand could be seen in the daytime during weekends as opposed to the weekdays, where a higher number of EVs are charged at night hours.

2) *Individual EV load demand*: The individual EV load demand in **CS1** is represented in Fig. 11(a). According to the figure, all five places contain different peak hours and off-peak hours. In fact, the EV load demand in residential areas has two peaks in the morning and night-time, exactly from 06:00-08:00 in the morning and 20:00-22:00 at night. The morning peak value is around 120kW, and the night-time peak value is higher than that, which is approximately 160kW. Nevertheless, the EV load demand is less than 20kW during the daytime in residential areas. This is because, many people drive for their day-to-day works such as schools and offices during weekdays, and only stay at homes during early mornings and nights. However, the EV load demand near the public park has presented a peak of around 115kW from 19:00-21:00 and a significantly lower number of EVs have been charged during the daytime, which is less than 25kW, as fewer people go for entertaining during weekdays. On the other hand, EV load demand in office area includes two peaks during the morning and evening, specifically, 09:00-11:00 (120kW) in the morning and 17:00-19:00 in the evening (140kW), because office working hours in the selected city is from 09:00 to 17:00. Further, with respect to the trend in shopping mall, higher number of EVs were charged from 11:00-14:00 and 18:00-21:00 throughout the day, where the peak values are about 100kW and 120kW, respectively. And a significant reduction (around 80kW) could be seen in the shopping mall after 14:00-17:00 and increased again by 100kW within next 4 hours. This is because more people tempt to go to the shopping mall during the lunch break or after work. Finally, the EV peak loads demand in the restaurant are nearly 120kW and 140kW in lunch time (from 11:00-14:00) and dinner time (from 17:00-19:00). Overall, a few numbers of EVs have been charged during the early morning in all five PLs. Individual load demand in **CS2** in the city is represented in Fig. 11(b). With respect to the figure, all the places have two peaks during the daytime and the night-time. In particular, the residential area EV load contains two peaks around 08:00-10:00 in the morning and 20:00-22:00 the night-time, which the peak is nearly 160kW in both peak times. This is because, many people tempt to stay home few more hours in the morning since it is a weekend. Further, the EV load demand during off-peak time is nearly 40kW in the residential areas. In addition, since it is a sunny weekend, the public park demand contains two peaks such as approximately 160kW and 150kW, from 09:00-11:00 and 16:00-18:00, respectively. And the trend has

decreased significantly after 18:00. However, the offices EV load demand is comparatively less than other areas since it is a weekend. In addition, the peak EV demand near shopping mall is 60kW higher than peaks in weekdays, where the peak load is around 160kW during daytime (from 11:00-15:00). And a notable reduction could be seen in shopping mall EV load after 16:00, due to most of the shops are closing by 16:00 in the city during weekend. Ultimately, the EV load demand near restaurant includes two peaks from 11:00-14:00 and 18:00-20:00, where the peak values are 140kW and 150kW, respectively. Further, a significant rise is shown in the restaurant area from 09:00-11:00 and the trend decreased from 15:00-17:00. However, people do not prefer to charge their EV batteries during early morning and late-night hours in all five places. The individual load demand in **CS3** in the city is demonstrated in Fig. 11(c). Overall, there is a remarkable difference between the EV load demand in residential area and other four areas. In specific, the residential EV load has two peaks during daytime and night-time, such as 180kW from 12:00-15:00 and 160kW from 20:00-23:00, respectively, where the average peaks values of public park, shopping mall and restaurant is less than 100kW. Further, EV load demand in residential areas has been accelerated by nearly 100kW from 07:00-11:00 and decreased the demand from 160kW to 40kW within 4 hours after 15:00. However, the off-peak demand is maintaining the average of 40kW in the residential areas. Apart from residential area, only office area has shown a peak value which is higher than 100kW such as around 150kW from 08:00-09:00. This is obvious, as most people prefer to stay at home or go for their important works (office) and less attention is given to the entertainment when it is raining. The EVs charging demand in **CS4** in the city is elaborated in Fig. 11(d). As shown in the figure, a higher number of EVs have been charged in the residential area compared to other areas. In fact, the peak hours in the residential area are from 20:00-23:00, and the average peak value is 120kW. A significant rise could be seen in the residential EV load demand from 14:00-19:00, where the value is charged from 20kW to 140kW. Further, none of the areas contain any peak values during the daytime. The EV load demand in public park is less than 40kW, while the office EV demand is fluctuating between 0kW to 60kW throughout the day. Nevertheless, shopping mall EV load contains two peaks from 10:00-13:00 (60kW) and 15:00-17:00 (80kW), which confirms that people prefer to stay more hours inside the shopping mall when it is raining. In addition, fewer EVs were charged in the restaurant area over the day, which is less than 60kW. Overall, it is clear that people tempt to stay at home and do indoor shopping when it is a rainy weekend.

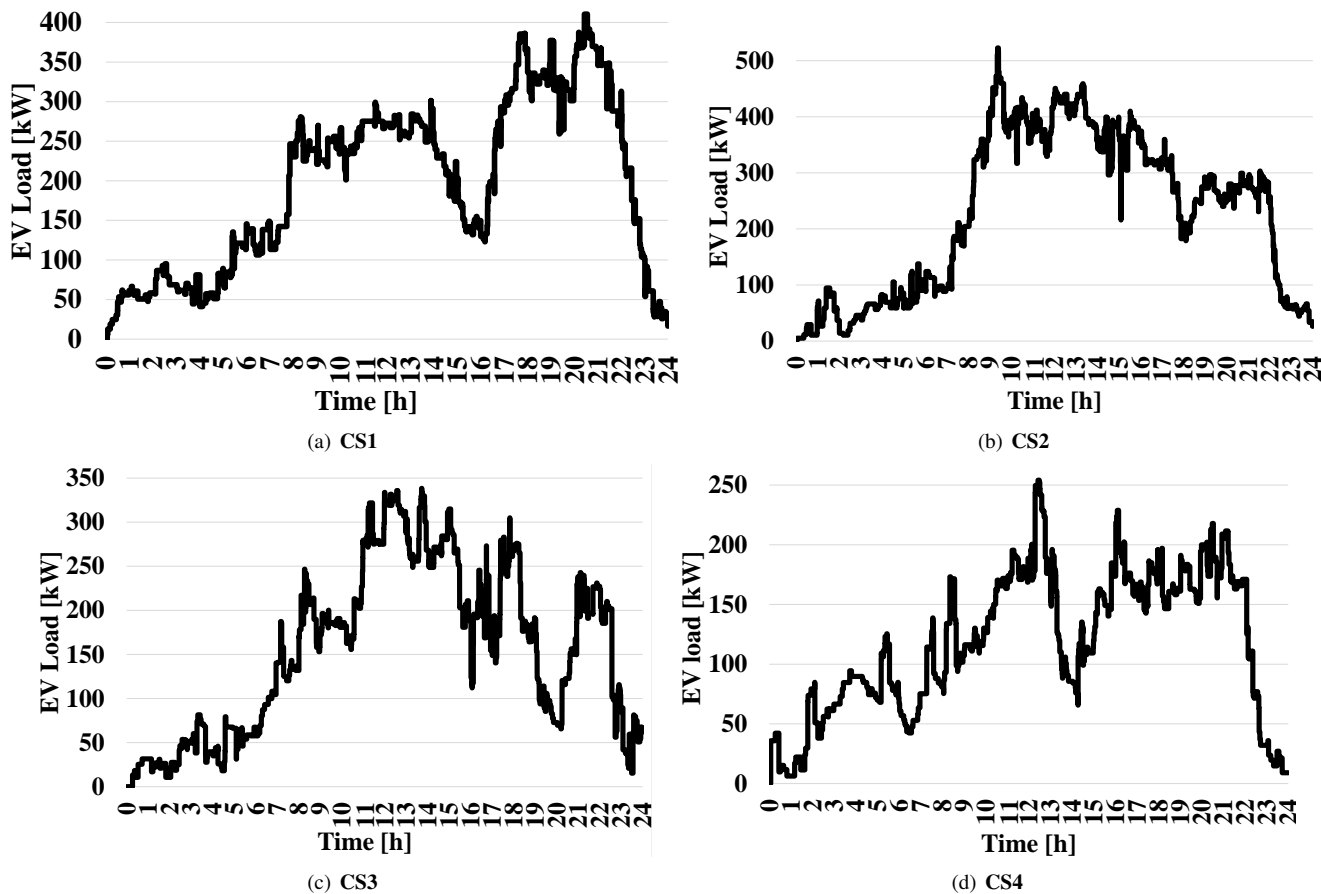

Fig. 10. Total EVs load demand (aggregator load profile).

3) *PLs optimal location*: Fig. 12 represents the optimal location determined by the proposed framework for PLs (RC3). These results are obtained from the proposed algorithm shown in Fig. 3. In the proposed method, a stochastic agent-based framework is used using Matpower and NETLOGO for observing the EVs charging behaviour to forecast the electricity demand in the PLs. Also, micro- and macro-level parameters of all stakeholders including EVs, PL aggregators, PL operators, and distribution network operator are considered which leads to find the optimal locations of PLs in the city and guarantee the maximum utilization of the PL infrastructure. In this regards, Matpower software was used to determine the optimal power flow (OPF) and identify the optimal locations, aiming at a minimum price for EVs, minimum charging load, maximum EV driver's satisfaction, as well as the minimum force given to the power grid for new charging stations. To facilitate power flow calculations and visualize the network, the proposed model has mapped the traffic map of the city to the IEEE-33 bus system and determined the optimal locations for PLs using an accurately predicted load profile.

V. CONCLUSIONS

The uncontrollable EV penetration has led to tremendous excess force on the current local power grid. In fact, sudden power failures (blackouts) could be expected due to the stress on the grid during peak hours and unnecessary fluctuations. Therefore, it is important to implement a controlled and

sustainable power system to supply the growing demand of EV. This proposed study has evaluated a reliable day-ahead charging behaviour while considering initial and final SOC, day type, local traffic pattern, and weather condition on a typical day. In addition, five different places have been selected to investigate the driving behaviour of the EVs such as residential, offices, shopping malls, restaurants, and public parks. Further, the model was implemented in agent-based software named NETLOGO and the path tracing algorithm has been utilized to identify the nearest PL to the EVs when the battery needs to recharge. Moreover, transport data and weather data were based on Newcastle Upon Tyne, The United Kingdom to evaluate the real scenario for the implemented model. Eventually, the results confirm that EVs are more active during sunny days compared to rainy days, more people prefer to stay at homes during rainy days, where the EV peak load in sunny weekday is nearly 400kW and EV load demand in rainy weekday is approximately 325kW. Therefore, more power is expected in sunny days. Further, during weekdays, higher number of EVs are charging during night-time, specially in residential areas and as opposed to office areas where the peak load can be seen in the daytime. In addition, the fluctuating demand of each area in different conditions could result in unexpected off-peaks and peak demands in the power grid. Therefore, the optimal locations for the PL in the city have been presented in the model to reduce the unnecessary impact to the electrical distribution network. For

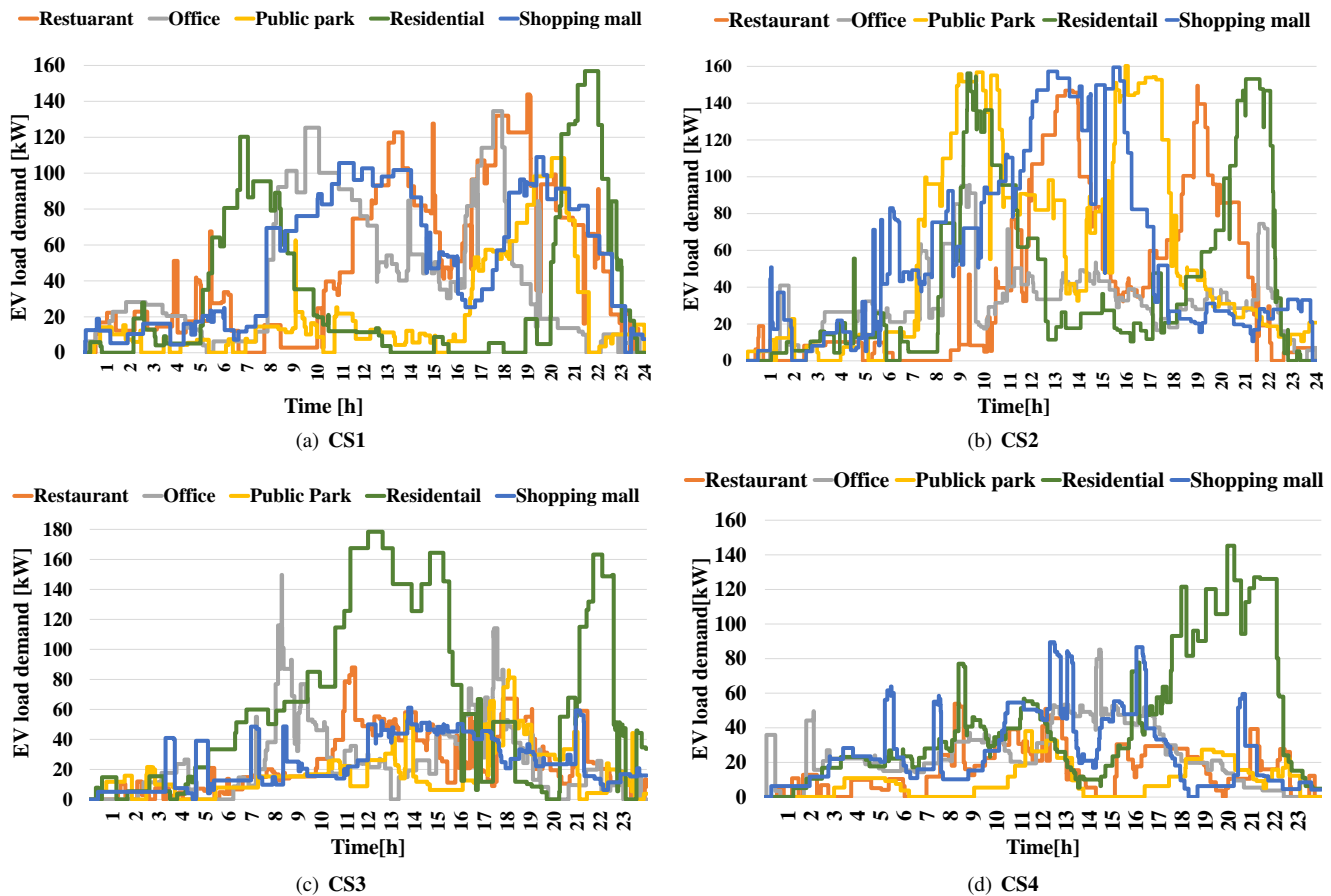

Fig. 11. The individual EV load profile (CS/ PL operator load profile).



Fig. 12. Optimal location of PLs obtained by the proposed framework.

future works considering non-technical concerns such as the feasibility of constructing PL in different locations can be considered. Furthermore, the participation of PLs in ancillary services markets to obtain more benefits and also resolving network issues can be of interest.

REFERENCES

- [1] E. Apostolaki-Iosifidou, P. Codani, and W. Kempton, "Measurement of power loss during electric vehicle charging and discharging," *Energy*, vol. 127, pp. 730–742, 2017.
- [2] S. E. Ahmadi, S. M. Kazemi-Razi, M. Marzband, A. Ikpehai, and A. Abusorrah, "Multi-objective stochastic techno-economic-environmental optimization of distribution networks with G2V and V2G systems," *Electric Power Systems Research*, vol. 218, p. 109195, 2023.
- [3] S. Deshmukh (Gore), A. Iqbal, S. Islam, I. Khan, M. Marzband, S. Rahman, and A. M. Al-Wahedi, "Review on classification of resonant converters for electric vehicle application," *Energy Reports*, vol. 8, pp. 1091–1113, 2022.
- [4] T. Wills. (2020) Briefing document the UK's transition to electric vehicles. [Online]. Available: <https://www.theccc.org.uk/wp-content/uploads/2020/12/The-UKs-transition-to-electric-vehicles.pdf>.
- [5] S. E. Ahmadi, M. Marzband, A. Ikpehai, and A. Abusorrah, "Optimal stochastic scheduling of plug-in electric vehicles as mobile energy storage systems for resilience enhancement of multi-agent multi-energy networked microgrids," *Journal of Energy Storage*, vol. 55, p. 105566, 2022.
- [6] J. Zhang, J. Yan, Y. Liu, H. Zhang, and G. Lv, "Daily electric vehicle charging load profiles considering demographics of vehicle users," *Applied Energy*, vol. 274, p. 115063, 2020.
- [7] S. A. Mansouri, A. Rezaee Jordehi, M. Marzband, M. Tostado-Véliz, F. Jurado, and J. A. Aguado, "An IoT-enabled hierarchical decentralized framework for multi-energy microgrids market management in the presence of smart prosumers using a deep learning-based forecaster," *Applied Energy*, vol. 333, p. 120560, 2023.
- [8] S. Islam, A. Iqbal, M. Marzband, I. Khan, and A. M. Al-Wahedi, "State-of-the-art vehicle-to-everything mode of operation of electric vehicles and its future perspectives," *Renewable and Sustainable Energy Reviews*, vol. 166, p. 112574, 2022.
- [9] S. A. Mansouri, E. Nematbakhsh, A. Ahmarinejad, A. R. Jordehi, M. S. Javadi, and M. Marzband, "A hierarchical scheduling framework for resilience enhancement of decentralized renewable-based microgrids considering proactive actions and mobile units," *Renewable and Sustainable Energy Reviews*, vol. 168, p. 112854, 2022.
- [10] A. S. Daramola, S. E. Ahmadi, M. Marzband, and A. Ikpehai, "A cost-effective and ecological stochastic optimization for integration of

- distributed energy resources in power networks considering vehicle-to-grid and combined heat and power technologies,” *Journal of Energy Storage*, vol. 57, p. 106203, 2023.
- [11] C. Yuen and A. Harvey, “Charging in progress: the future of electric vehicle charging infrastructure in the UK,” <https://www.ashurst.com/en/news-and-insights/insights/the-future-of-electric-vehicle-charging/>, 2020.
- [12] F. Ahmad, I. Ashraf, A. Iqbal, M. Marzband, and I. Khan, “A novel AI approach for optimal deployment of EV fast charging station and reliability analysis with solar based DGs in distribution network,” *Energy Reports*, vol. 8, pp. 11 646–11 660, 2022.
- [13] M. Nasir, A. Rezaee Jordehi, M. Tostado-Véliz, S. A. Mansouri, E. R. Sanseverino, and M. Marzband, “Two-stage stochastic-based scheduling of multi-energy microgrids with electric and hydrogen vehicles charging stations, considering transactions through pool market and bilateral contracts,” *International Journal of Hydrogen Energy*, 2023.
- [14] R. Khalili, A. Khaledi, M. Marzband, A. F. Nematollahi, B. Vahidi, and P. Siano, “Robust multi-objective optimization for the Iranian electricity market considering green hydrogen and analyzing the performance of different demand response programs,” *Applied Energy*, vol. 334, p. 120737, 2023.
- [15] Q. Huang, L. Yang, C. Hou, Z. Zeng, and Y. Qi, “Event-based EV charging scheduling in a microgrid of buildings,” *IEEE Transactions on Transportation Electrification*, 2022.
- [16] S. E. Ahmadi, M. Marzband, A. Ikpehai, and A. Abusorrah, “Optimal stochastic scheduling of plug-in electric vehicles as mobile energy storage systems for resilience enhancement of multi-agent multi-energy networked microgrids,” *Journal of Energy Storage*, vol. 55, p. 105566, 2022.
- [17] S. E. Ahmadi, D. Sadeghi, M. Marzband, A. Abusorrah, and K. Sedraoui, “Decentralized bi-level stochastic optimization approach for multi-agent multi-energy networked micro-grids with multi-energy storage technologies,” *Energy*, vol. 245, p. 123223, 2022.
- [18] S. Bae and A. Kwasinski, “Spatial and temporal model of electric vehicle charging demand,” *IEEE Transactions on Smart Grid*, vol. 3, no. 1, pp. 394–403, 2011.
- [19] F. Ahmad, A. Iqbal, I. Ashraf, M. Marzband, and I. Khan, “Placement and capacity of EV charging stations by considering uncertainties with energy management strategies,” *IEEE Transactions on Industry Applications*, pp. 1–10, 2023.
- [20] F. H. Aghdam, M. W. Mudiyansele, B. Mohammadi-Ivatloo, and M. Marzband, “Optimal scheduling of multi-energy type virtual energy storage system in reconfigurable distribution networks for congestion management,” *Applied Energy*, vol. 333, p. 120569, 2023.
- [21] K. Saberi-Beglar, K. Zare, H. Seyedi, M. Marzband, and S. Nojavan, “Risk-embedded scheduling of a CCHP integrated with electric vehicle parking lot in a residential energy hub considering flexible thermal and electrical loads,” *Applied Energy*, vol. 329, p. 120265, 2023.
- [22] N. H. Tehrani and P. Wang, “Probabilistic estimation of plug-in electric vehicles charging load profile,” *Electric Power Systems Research*, vol. 124, pp. 133–143, 2015.
- [23] S. Zeynali, N. Nasiri, S. N. Ravadanegh, and M. Marzband, “A three-level framework for strategic participation of aggregated electric vehicle-owning households in local electricity and thermal energy markets,” *Applied Energy*, vol. 324, p. 119749, 2022.
- [24] Z. Wang, P. Jochem, and W. Fichtner, “A scenario-based stochastic optimization model for charging scheduling of electric vehicles under uncertainties of vehicle availability and charging demand,” *Journal of Cleaner Production*, vol. 254, p. 119886, 2020.
- [25] H. Jahangir, H. Tayarani, A. Ahmadian, M. A. Golkar, J. Miret, M. Tayarani, and H. O. Gao, “Charging demand of plug-in electric vehicles: Forecasting travel behavior based on a novel rough artificial neural network approach,” *Journal of cleaner production*, vol. 229, pp. 1029–1044, 2019.
- [26] A. Shahkamrani, H. Askarian-Abyaneh, H. Nafisi, and M. Marzband, “A framework for day-ahead optimal charging scheduling of electric vehicles providing route mapping: Kowloon case study,” *Journal of Cleaner Production*, vol. 307, p. 127297, 2021.
- [27] A. Pal, A. Bhattacharya, and A. K. Chakraborty, “Allocation of electric vehicle charging station considering uncertainties,” *Sustainable Energy, Grids and Networks*, vol. 25, p. 100422, 2021.
- [28] S. S. Karimi Madahi, H. Nafisi, H. Askarian Abyaneh, and M. Marzband, “Co-optimization of energy losses and transformer operating costs based on smart charging algorithm for plug-in electric vehicle parking lots,” *IEEE Transactions on Transportation Electrification*, vol. 7, no. 2, pp. 527–541, 2021.
- [29] A. Mansour Saatloo, A. Mehrabi, M. Marzband, and N. Aslam, “Hierarchical user-driven trajectory planning and charging scheduling of autonomous electric vehicles,” *IEEE Transactions on Transportation Electrification*, vol. 9, no. 1, pp. 1736–1749, 2023.
- [30] A. Pal, A. Bhattacharya, and A. K. Chakraborty, “Planning of EV charging station with distribution network expansion considering traffic congestion and uncertainties,” *IEEE Transactions on Industry Applications*, 2023.
- [31] Netologo. (2021) netologo. [Online]. Available: <https://ccl.northwestern.edu/netlogo/>
- [32] C. B. Saner, A. Trivedi, and D. Srinivasan, “A cooperative hierarchical multi-agent system for EV charging scheduling in presence of multiple charging stations,” *IEEE Transactions on Smart Grid*, vol. 13, no. 3, pp. 2218–2233, 2022.
- [33] F. Ahmad, A. Iqbal, I. Ashraf, M. Marzband, and I. Khan, “Optimal location of electric vehicle charging station and its impact on distribution network: A review,” *Energy Reports*, vol. 8, pp. 2314–2333, 2022.
- [34] N. E. U. T. Management and C. O. D. Service, “UTMC open data service,” https://www.netraveldata.co.uk/?page_id=32, 2022.
- [35] U. Wilensky, “Netlogo,” <http://ccl.northwestern.edu/netlogo/>.
- [36] K. Chaudhari, N. K. Kandasamy, A. Krishnan, A. Ukil, and H. B. Gooi, “Agent-based aggregated behavior modeling for electric vehicle charging load,” *IEEE Transactions on Industrial Informatics*, vol. 15, no. 2, pp. 856–868, 2018.