

# Enhancing the axial resolution of an optoacoustic microscopy imaging instrument by using a pico-second pulse duration laser

Gianni Nteroli,<sup>a,\*</sup> Giulia Messa,<sup>b</sup> Stella Koutsikou<sup>b</sup>, Manoj K. Dasa,<sup>c</sup> Antti Penttinen,<sup>d</sup> Antti Härkönen,<sup>d</sup> Mircea Guina,<sup>d</sup> Adrian Podoleanu<sup>a</sup>, and Adrian Bradu<sup>a</sup>

<sup>a</sup>Applied Optics Group, School of Physics and Astronomy, University of Kent, Canterbury, UK

<sup>b</sup>Medway School of Pharmacy, University of Kent, Chatham, UK

<sup>c</sup>DTU Fotonik, Technical University of Denmark, 2800 Kgs. Lyngby, Denmark

<sup>d</sup>Optoelectronics Research Centre, Physics Unit, Tampere University, P.O. Box 692, FI-33014 Tampere, Finland

\*Corresponding author: g.nteroli@kent.ac.uk

## ABSTRACT

In conventional optoacoustic microscopy, nanosecond pulse duration lasers are employed. When a laser delivering shorter pulse durations is used, it is expected that, from a theoretical point of view, broader, higher-frequency acoustic waves to be generated, therefore a better axial resolution of the instrument. In the present report, this advantage, offered by a picosecond duration pulse laser, to experimentally demonstrate that the axial resolution of an optoacoustic microscopy instrument can be enhanced was exploited. In comparison to a 2 ns pulse duration, an improvement in the axial resolution of ~50% is demonstrated by using excitations with pulses of duration <100 ps. Details of an optoacoustic microscopy instrument, operating at 532 nm, capable to provide high-resolution axial and lateral optoacoustic images, are also presented. The capabilities of the instrument are demonstrated by *in-vivo* images of *Xenopus laevis* brain with a similar ~3.8  $\mu\text{m}$  lateral resolution throughout the whole axial imaging range.

**Keywords:** Optoacoustic Imaging, axial resolution, pico-second lasers

## 1. INTRODUCTION

In optoacoustic microscopy (OAM), the axial resolution is decoupled from the lateral one, being determined by the electrical bandwidth of the ultrasound transducer (UT) employed and the speed of the acoustic wave within the material investigated. An excellent axial resolution is therefore ensured by a UT whose bandwidth matches the bandwidth range of the acoustic signals generated. However, in most of the reports on OAM, a ns pulse duration laser is used as an excitation source in conjunction with a large bandwidth single-element UT, and as a result, the axial resolution is mainly governed by the frequencies of the acoustic waves instead. The number of reports experimentally demonstrating that by using pulses of shorter duration, broader frequency acoustic waves are generated is limited. Irisawa et al [1] for example reported improvement in axial resolution when a 4.5 ns pulse duration laser was used instead of 45 ns pulse duration one. To our knowledge, no reports exist on experimentally demonstrating further improvements in axial resolution, when pulse durations shorter than several nanoseconds are used. Here, a compact Q-switched microchip laser delivering pulses of <100 ps at 532 nm is employed, and incorporated into an imaging instrument. The axial resolution achieved by using such a laser is compared to that of a supercontinuum optical source operating at the same wavelength but delivering a pulse duration of 2 ns. We demonstrate that the available ps laser not only enables high-resolution imaging attributed to the broader frequency acoustic signals generated but due to its high repetition rate, also enables *in-vivo* real-time operation. The transversal resolution of the instrument presented here depends on the interface optics, mainly on the numerical aperture of the microscope objective employed to focus light on the sample. To improve the lateral resolution, a high numerical aperture microscope objective was used. The immediate drawback of this approach is a limited axial imaging range restricted to the extension of the confocal gate. We found that a solution suitable for high numerical aperture interface optics can be the Gabor method [2], currently used with optical coherence tomography instruments, method that can be extended to OAM. Using this method, data acquisition is repeated for several focusing positions, corresponding to various shifts of the confocal gating profile through the sample depth. The images obtained are then fused to form a final larger image extended over a wider axial range. As the data acquisition must be performed multiple times, the real-time operation of the instrument is limited, however, an excellent constant lateral resolution throughout a long axial range is conserved.

## 2. METHODS

*In-vivo* imaging was performed on *Xenopus laevis* tadpoles at developmental stage 37/38. All experimental procedures were approved by the University of Kent Animal Welfare and Ethical Review Body (AWERB; Institutional Ethics Reference Number: 0037-SK-17).

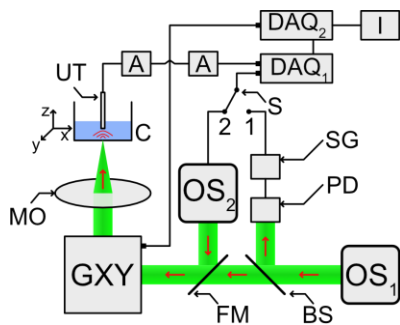

Figure 1. Experimental set-up. OS<sub>1</sub>: ns pulse duration laser; OS<sub>2</sub>: ps pulse duration laser; MO: microscope objective; C: cuvette; UT: transducer; A: amplifiers; DAQ<sub>1,2</sub>: data acquisition boards; I: image; S: switch; GXY: galvo-scanners; FM: flipping mirror; BS: beam-splitter; PD: photo-detector; SG: signal generator.

The schematic of the OAM instrument employed is presented in Fig. 1. OS<sub>1</sub> is a Q-switch laser emitting at 532 nm (Picophotonics Ltd, Tampere, Finland). It generates pulses with a duration of ~100 ps, repetition rate 50 kHz, and delivers an average optical power of 16 mW. Compared to other types of lasers used in OAM, such as frequency converted ns Q-Switch lasers or supercontinuum fibre systems [3,4] the Picophotonics laser offers other advantageous features, i.e. higher repetition rate than standard Q-Switch systems and/or higher pulse energy compared to mode-locked systems. Moreover, the laser has a small footprint (15×15×12 cm<sup>3</sup>) and simple architecture, which makes it advantageous also compared to solutions based on amplified gain-switched lasers. For synchronization purposes, a fast photo-detector (PD) and a waveform signal generator (SG) are employed to produce a TTL signal to drive the acquisition through a 12-bit fast acquisition board (DAQ<sub>1</sub>) operating at a sampling rate of 200 MS/s (PCI-5124, National Instruments). OS<sub>2</sub> is a supercontinuum optical source (SuperK Compact, NKT Photonics) delivering pulses at 20 kHz of 2 ns duration.

The instrument has two operating modes, depending on the positions of a flipping mirror (FM) and of a switch S: (1) System is driven by light from the optical source OS<sub>1</sub> with switch S is in position 1. (2) System is driven by light from the optical source OS<sub>2</sub> with S in position 2.

The samples were submerged in water to facilitate acoustic coupling. The sample holder (cuvette C) is mounted on a 3D translation stage to position the sample accurately. The acoustic waves are detected with a high-frequency ultrasonic transducer UT (central frequency 50 MHz, PA1199, Precision Acoustics) placed in contact with the water. The electrical signal generated by the UT is amplified by two low-noise wideband amplifiers (ZFL-500LN+, Mini-Circuits) connected in series and then digitized by the DAQ<sub>1</sub>. A second digitizer (DAQ<sub>2</sub>) is used to drive the galvo-scanners.

## 3. DISCUSSIONS AND CONCLUSIONS

Several experiments were conducted to evaluate the OAM system imaging capabilities, such as spatial resolution, and the signal-to-noise ratio (SNR). To evaluate the lateral resolution, a standard procedure has been employed [4], by imaging the sharp edge of a positive USAF target. From these images, a lateral resolution of the system of 3.8 μm was measured, close to the expected theoretical value. To measure the axial resolution, a carbon fiber tape was imaged using both sources. Both OS<sub>1</sub> and OS<sub>2</sub> delivered the same energy per pulse, therefore provided similar optoacoustic SNRs (42.9 and 43.8 dB, respectively), however, in terms of the axial resolutions, a ~50% enhancement is obtained when using ps pulses in comparison to the ns ones. This is illustrated in Fig. 2, where the acoustic spectra produced with the two sources, are presented. The ps-induced signals show a central frequency at ~41 MHz, whereas the ns-induced signal shows a central frequency at ~30 MHz. The axial resolution of 25 μm obtained with the ps laser, whereas when employing the ns laser, the axial resolution is 51 μm.

To illustrate the capability of the instrument to produce high-quality images in the ps regime, the brain of a *Xenopus laevis* tadpole was imaged. During imaging, animals were immobilized and positioned on a 3D printed sample holder designed to keep the animal submerged in saline solution, while the laser beam scanned the sample from below (Fig. 1). B-scan images were produced and displayed in real-time at a frame rate of 20 Hz. A 3D volume was generated in 20 s. To enhance the SNR, 32 A-scans were averaged, extending the acquisition time to 10.7 min. To preserve the lateral resolution throughout the whole volume, images at different axial focusing positions were acquired by shifting the sample in increments of 50 μm along the axial direction. In Fig. 3, *en-face* images at different imaging depths are presented, clearly showing the tadpole's brain anatomy. Images at different depths were colour-coded and then combined into a composite one (Fig. 3(a)). Although consecutive images were obtained shifting the focal point in steps of 50 μm, only images showing significant changes are presented (in steps of 200 μm).

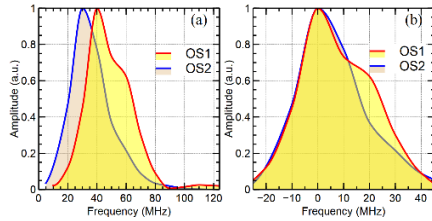

Figure 2. (a) Normalized acoustic spectra measured with the two sources showing that when the ps source is employed higher frequency components are produced. (b) Same as in (a), however, to illustrate that the spectral bandwidth of the acoustic signals is wider when the ps source is used, the two spectra are shifted in frequency so that their maxima are at 0 MHz.

To conclude, we experimentally demonstrated that the axial resolution of an OAM instrument can be improved by narrowing the pulse duration of the excitation laser, therefore higher axial resolution images can be produced. More precisely, using a ps laser, we experimentally proved an improvement in the axial resolution of 50% better than when employing a 2 ns pulse duration laser. It is expected that by using narrower laser pulses, the axial resolution to be improved even further. To take full advantage of the enhancement in axial resolution, further investigations are needed as soon as faster UTs become available, and short laser pulse technologies are developed. To achieve constant high lateral resolution along the axial direction, and therefore be able to differentiate the anatomical brain structures of the tadpole, repetitive imaging at 50  $\mu\text{m}$  increments was performed. Although the B-scan images were produced in real-time, the combined image presented in Fig. 3(a) required a quite long post-processing time. To overcome this drawback, higher pulse repetition rates must be used in an instrument equipped with a fast-focusing capability and harness the computing power of the graphics cards to improve the post-processing time.

## ACKNOWLEDGEMENTS

GN and GM thank the support of the University of Kent. AP and AB acknowledge the support of BBSRC project, BB/S016643/1; AGhP and MG acknowledge the EU's Horizon 2020 programme (Marie Skłodowska-Curie grant 860807). AGhP further acknowledges the NIHR Biomedical Research Centre, UCL Institute of Ophthalmology, and the Royal Society Wolfson research merit award. SK acknowledges The Physiological Society UK (Research Grant 2019). MKD acknowledge EU's Horizon 2020 programme (Marie Skłodowska-Curie, 722380). AGhP, AH, and MG acknowledge Business Finland (TEMPO, 168/31/2020). AB also acknowledges the support of the Royal Society, project PARSOCT, RGS/R1/221324 and the support of the Academy of Medical Sciences/the Wellcome Trust/the Government Department of Business, Energy and Industrial Strategy/the British Heart Foundation/Diabetes UK Spring-board Award SBF007\100162.

## REFERENCES

1. Irisawa, K., Hirasawa, T., Hirota, K., Tsujita, K. & Ishihara, M. Influence of laser pulse width to the photoacoustic temporal waveform and the image resolution with a solid-state excitation laser, *Proc. SPIE* 8223, 79 2012.
2. Rolland, J. P., Meemon, P., Murali, S., Thompson, K. P., and Lee, K., "Gabor-based fusion technique for Optical Coherence Microscopy," *Optics Express* 18, 3632–3642 2010.
3. Cho, S.-W. et al. High-speed photoacoustic microscopy: A review dedicated on light sources. *Photoacoustics* 24, 100291 (2021).
4. Dasaa, M., Nteroli, G., Bowen, P., Messa, G., Feng, Y., Petersen, C., Koutsikou, S., Bondu, M., Moselund, P., Podoleanu, A., Bradu, A., Markos C., and Bang, O., "All-fibre supercontinuum laser for in vivo multispectral photoacoustic microscopy of lipids in the extended near-infrared region," *Photoacoustics* 100163, 18 2020.

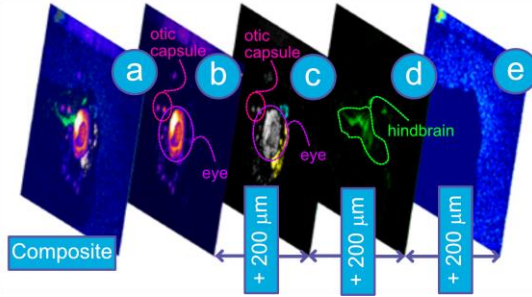

Figure 3. (a) Composite *en-face* image obtained by merging images collected at 24 axial positions separated by 50  $\mu\text{m}$ . (b)-(e): images showing significant examples of defined brain structures that appear as the focal plane is shifted deeper into the tadpole.