

The Implementation of Mamdani's Fuzzy Model for Controlling the Temperature of Chicken Egg Incubator

Indri Nurfazri Lestari
Department of Electrical Engineering
UIN Sunan Gunung Djati Bandung
Bandung, Indonesia
indrinfazri168@gmail.com

Edi Mulyana
Department of Electrical Engineering
UIN Sunan Gunung Djati Bandung
Bandung, Indonesia
edim@uinsgd.ac.id

Rina Mardiaty
Department of Electrical Engineering
UIN Sunan Gunung Djati Bandung
Bandung, Indonesia
r_mardiaty@uinsgd.ac.id

Abstract— Today, development of technology is rapidly growing in many fields, including in animal husbandry. This technology could be applied in the process of hatching eggs in chicken farms. Since the process of hatching egg was become an important process that correlated with the failure rate in hatching eggs. In order to get an optimal process of hatching eggs, temperature must be controlled as closely as an ideal temperature, which is around 37-40 Celsius. This study builds the prototype of chicken egg incubator system whose temperature was controlled using a Mamdani logic fuzzy control, so it's can run optimally. We use DFT11 sensor to get the temperature and humidity of incubator as an input of fuzzy logic. Using a fuzzy logic to control the temperature, the output of this system is the speed of fan (PWM). Furthermore, we use 2 lamps to make the temperature warmer, so that the temperature of this incubator could be control in an ideal temperature. We do software testing and overall system performance testing. Software testing is carried out to see whether the implemented fuzzy logic is in accordance with the expected, by comparing the results obtained from a system built with manual calculations and simulation calculations. Based on the test results, it is found that the fuzzy system has been implemented successfully with 47.36% success. While the results of the overall system performance test show that the system being built has worked well.

Keywords— *Chicken Egg Incubator, Fuzzy Logic, Mamdani, Temperature Control.*

I. INTRODUCTION

In daily life, human being's activities require stable temperature both for their comfort in their activities and for their work as in poultry farms [1]. The process of hatching eggs in the field of animal husbandry is very important [2]. The process of hatching eggs naturally can be done by eggs incubating by the hen. The incubator is one of the replacement tools to hatch chicken eggs [3]. Incubation is the process of keeping the fertilized eggs warm in order to allow proper development of the embryo into a chick [4]. This incubator is made to resemble the procedure for incubating chicken eggs with maintained temperature and humidity inside the incubator at optimal values tilts the egg make sure all parts of the egg is heated by a heater element until hatch the egg [5] [6]. With the fuzzy method itself is widely used as intelligent control because it can determine variables with thoughts like humans. In order to get this process of hatching eggs become optimal, it needs the incubator system that can control the temperature, humidity and oxygen which are essential to

improve quality and hatchability of chicks. humidity and temperature always stable.

There are some literatures has been done in developing the incubator system for egg. Makondo et al. try to developed an egg hatching incubator for different species of bird using Fuzzy Logic Mamdani [5]. They use the body temperature of different birds as an input to predict the accurate temperature, humidity and hatching period of egg. Meanwhile, Prince et al. creates an incubator system based on fuzzy technology, the input is temperature and the output is the value of the temperature obtained by the LM35 sensor. They used microcontroller AT89C52 in this research [7]. Another study discusses the use of genetic algorithms (GA) in the design and implementation of fuzzy logic controllers (FLC) to incubate eggs. Genetic algorithm is used to improve the performance of the fuzzy controller [8]. In this research about Controlling Temperature of Chicken Egg Incubator Based on Mamdani Fuzzy Logic Control. This study uses two parameters namely temperature and humidity, the microcontroller used is Arduino Uno and its control system is Fuzzy Logic Control Mamdani. An optimal egg incubator is very related with the temperature of incubator. Setyaningsih study about the impact of position of heater and cooler in egg incubator [9][10].

This research will present the design of temperature control for egg incubator using fuzzy logic control Mamdani. The input is humidity and temperature, while the output of this system are speed of the fan and lamp. The Mamdani method prediction process consists of four stages, namely the formation of fuzzy sets (the formation of input variables and output variables divided into one or more fuzzy sets), the application of the implication function (the implication function is determined from the value in the form of the fuzzy set which is used as an implication that is the MIN value or the lowest value) rule composition (ways used to determine fuzzy set valuation), defuzzification (the last step for processing a fuzzy set obtained from fuzzy rule composition to produce output in the form of a number in the fuzzy set domain) [11]. One application of a fuzzy logic controller is used to control the temperature in chicken egg incubators.

II. DESIGN AND IMPLEMENTATION

Figure 1 shows the block diagram of our system. The parameters used in this study are humidity and temperature. Humidity and temperature are very important processes in hatching eggs.

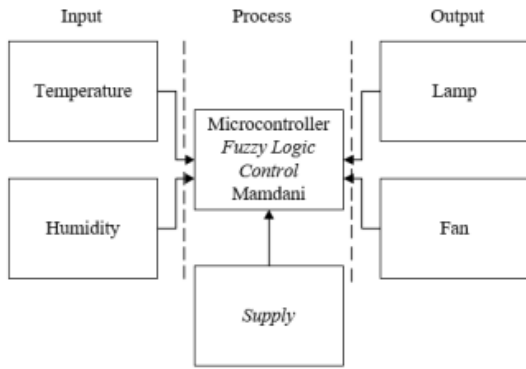

Fig. 1. The block diagram of egg incubator system.

A. Modeling Fuzzy Logic for Controlling The Temperature of Incubator

In this study, there are 2 input variables and 1 output variable. Variable the input consists of temperature and humidity and the output variable is fan speed (PWM). Table I and II is the term for the input variables and variables the output is used to facilitate the fuzzy control system on the incubator chicken eggs built.

TABLE I. LINGUISTIC TERM OF THE INPUT.

Humidity	Linguistic Term	Temperature	Linguistic Term
Dry	[0 0 16 33]	Cold	[32 32 35 37]
Normal	[16 33 49 66]	Normal	[35 37 40 42]
Moist	[49 66 100 100]	Hot	[40 42 47 47]

TABLE II. LINGUISTIC TERM OF THE OUTPUT.

Fan speed	Linguistic Term
Slow	[0 0 42 85]
Normal	[42 85 127 170]
Fast	[127 170 255 255]

The humidity variable is formed into three sets, namely Dry, Normal and Moist. The humidity variable is shown in Fig. 2. for this set use a trapezoidal curve shape.

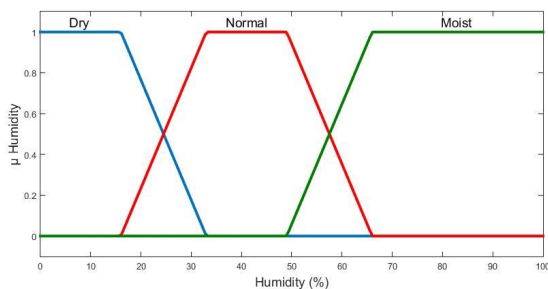

Fig. 2. Membership function of input humidity.

Furthermore, the temperature variable is formed into three sets, namely Cold, Normal and Hot. This variable are shown in Fig 3 as a membership function of input temperature.

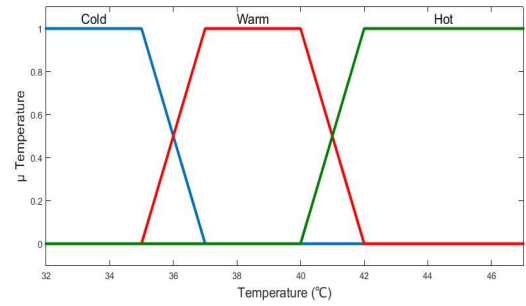

Fig 3. Membership function of input temperature.

The output variable, namely the fan speed, is formed into three sets i.e. slow, normal and fast as shown in the curve in Fig. 4.

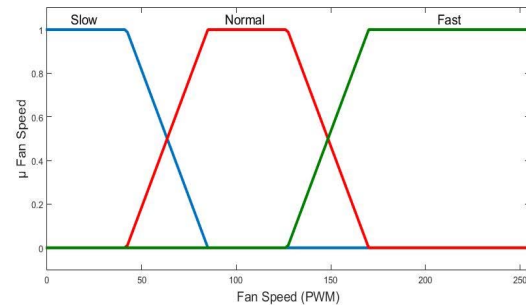

Fig. 4. Membership function of output fan speed

TABLE III. RULE FUZZY LOGIC

Rules	Input		Output
	Humidity	Temperature	
R1	Dry	Cold	Slow
R2	Normal	Cold	Slow
R3	Moist	Cold	Slow
R4	Dry	Normal	Slow
R5	Normal	Normal	Slow
R6	Moist	Normal	Slow
R7	Dry	Hot	Fast
R8	Normal	Hot	Fast
R9	Moist	Hot	Fast

If the humidity input is dry and the temperature input is cold, then the fan speed output is slow. Likewise, with the implementation of other rules.

B. Implementation

Egg incubator material made of Glassfibre Reinforced Cement (GRC). The dimensions or size of the designed egg incubator is 60 cm × 30 cm × 30 cm. Figure 4.13 shows the front of the machine tool automatic egg incubator designed.

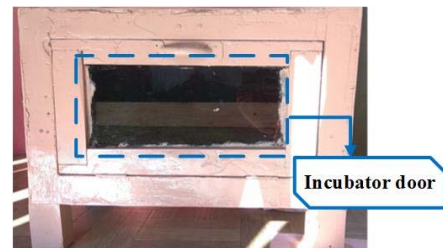

Fig. 5 Incubator door.

In the inner incubator according to Fig 6, some components support the inside. This research includes free-range chicken eggs, lights, DHT11 sensors, digital thermohygrometer, and egg shift motor.

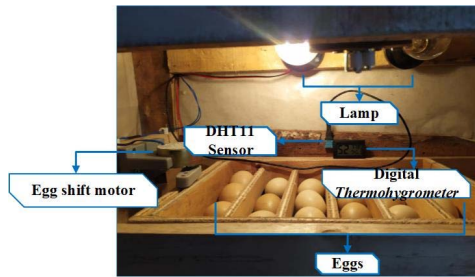

Fig. 6 Inner incubator.

On the back of the incubator frame, there is a power supply circuit by Fig 7. There are several components in the power supply circuit, including transformers, terminal blocks, capacitors, and diodes.

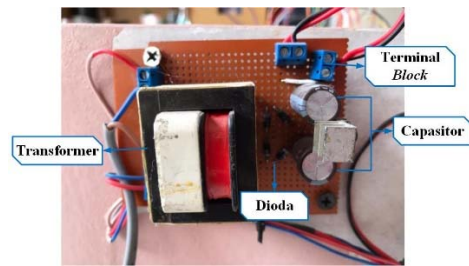

Fig. 7 Power supply circuit.

In the incubator frame, there is also a relay circuit, according to Fig 8. There are several components in the relay circuit, including terminal blocks, capacitors, jumper cables, and resistors.

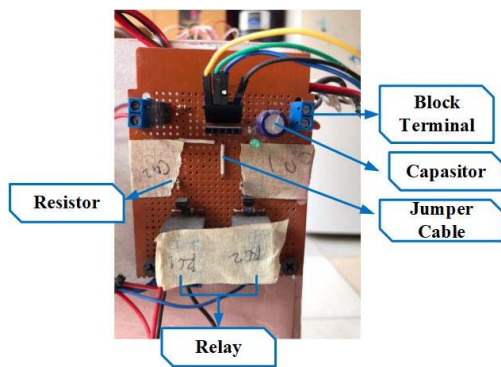

Fig. 8 Relay circuit.

III. TESTING AND ANALYSIS

This section will explain about hardware testing, software testing and system testing as a whole. This testing process is carried out to ensure the system is designed can go as planned.

A. Testing Hardware

In hardware testing is divided into several parts including testing hardware, temperature and humidity testing and transfer switch testing. Voltage regulator testing is done by

measuring the results The input voltage and output voltage results are shown in the Table 4 is as follows:

TABLE IV. TESTING HARDWARE

Device	Ideal Voltage (V)	Test Result Voltage (V)
Arduino	7-12 VDC	12.05 VDC
DC Fan	12 VDC	12.05 VDC
Driver Relay	5-7.5 VDC	5 VDC

The results of the stress test can be seen in Table 1, namely the load obtained an average of 12.05 V because the voltage read on the multimeter has the difference as well as the voltage already has a load and has an average error 5%. The existence of this error is due to the incoming current to an unstable power supply.

B. Temperature and Humidity Readings Testing

TABLE V. TEMPERATURE AND HUMIDITY READINGS TESTING.

DHT11 Sensor		Output	Thermohygrometer Digital		Error	
□	%RH	PWM	□	%RH	□	%RH
37.8	52	51	37.1	51	1.85	0.19
37.9	51	51	37.1	51	2.11	0

According to Table 5, overall the DHT11 sensor works well so that the sensor can be used in making this incubator.

C. Transfer switch testing

TABLE VI. TRANSFER SWITCH TESTING.

Testing criteria	Relay condition	Test Result
Temperature	ON	ON
Egg slide motor (every 2 hours)	ON	ON

According to Table 6, in the incubator the incandescent lamp is given 1 piece for gives the maximum temperature, the ideal temperature that is inside egg incubator namely 37 – 42°C. So when the temperature is less than 37°C then the incandescent lamp will turn on and when the temperature is inside the incubator is more than 42°C then the incandescent lamp will turn off automatically automatic. Temperature output that has been read by the temperature sensor will be displayed on the LCD.

When the tool is turned on, the initial temperature is read by The sensor is 27°C time to temperature setting point desired is 26 minutes 1 second, then when the temperature is over from 42°C it takes time to setting point which is 3 minutes 10 seconds.

D. Fuzzy Logic Control Modeling on the Incubator

Software testing is aims to check whether the control model is fuzzy that has been implemented in the chicken egg incubator is appropriate or not yet. The results obtained from the incubator's fuzzy control system were built, compared with manual calculations and calculation results using

simulation software. To test this, a case with temperature 37.8 °C and humidity 52%. Using a fuzzy control system will be searched the output value is the fan speed. In calculating the control system manually fuzzy with the example above, several steps need to be done, which will be discussed in the next detail.

Step 1. Determine the fuzzy set

Humidity

Based on the case above, the humidity is 52%. According to Figure 3, the humidity 52% is in the position of dry and normal condition. So, we will calculate the truth value (μ) of MF Normal and Moist for the humidity 52%. The detail calculation will be presented as follows.

$$\mu_{Normal}[52] = \frac{66-52}{17} = 0.8235 \quad (10)$$

$$\mu_{Moist}[52] = \frac{48-52}{-17} = 0.1764 \quad (11)$$

Temperature

Meanwhile, the temperature 37.8 °C is in the position of normal with degrees of membership according to the following functions:

$$\mu_{Normal}[37.8] = 1 \quad (12)$$

Step 2. The function implication

In this sub section, we substitute the value that already obtained in Equation (10) (11) (12) (13) to the all the rule in Table 5. We used the MIN function which means we take the minimum membership degree from the input variable as its output. From the 9 rules that presented in Table 5, only two rules are used, namely [R5] and [R6]. The detail calculation will be explained as follows.

[R5] : IF humidity is Normal **And** temperature is Normal

THEN PWM Output is Slow

$$\begin{aligned} \alpha_{R5} &= \mu_{Normal} \cap \mu_{Normal} \\ &= \min(\mu_{Normal}, \mu_{Normal}) \\ &= \min(0.823, 1) = 0.823 \end{aligned} \quad (13)$$

[R6] : IF humidity is Moist **And** temperature is Normal
THEN PWM Output is Slow

$$\begin{aligned} \alpha_{R6} &= \mu_{Moist} \cap \mu_{Normal} \\ &= \min(\mu_{Moist}, \mu_{Normal}) \\ &= \min(0.176, 1) = 0.176 \end{aligned} \quad (14)$$

Step 3. Defuzzification

Defuzzification is the last stage in a fuzzy logic system to convert each result from the inference engine expressed in terms of a fuzzy set of real numbers. At the stage this defuzzification uses the centroid method by searching the area areas and moments.

$$Z^* = \frac{\int \mu_x(z)zdz}{\int \mu_x(z)dz} \quad (15)$$

Where,

$\int \mu_x(z)zdz$: momen

$\int \mu_x(z)dz$: area

The next stage is to find the area and moment of the PWM output fan speed, there are two areas of area and moment on the PWM the fan speeds are then added up.

The output area at fan speed

$$L_{A1} = 50 \times 0.8 = 40$$

$$L_{A2} = \frac{85 - 43}{2} \times 0.8 = 16.8$$

$$L_{TOTAL} = 56.8 \quad (16)$$

The output moment at fan speed (PWM)

$$M_1 = \int_0^{50} 0.8z dz = 1000$$

$$M_2 = \int_{50}^{85} \frac{85 - 43}{2} z dz = 878.3914$$

$$M_{TOTAL} = 1878.3914 \quad (17)$$

To find out the fan speed PWM output value, use Equation 5.4 as below:

$$\begin{aligned} Z^* &= \frac{\int_0^{50} 0.8z dz + \int_{50}^{85} \left(\frac{85-z}{43}\right) z dz}{\int_0^{50} 0.8 dz + \int_{50}^{85} \left(\frac{85-z}{43}\right) dz} \\ &= 33.070 \text{ PWM} \end{aligned} \quad (18)$$

After manually calculating the generated PWM value with a case study of 52% humidity and temperature of 37.8°C, the results obtained the fan speed is 33,070 PWM. The same is the case in software simulation according to data at the same time, the fan speed of 33.8 PWM is obtained according to Fig 9.

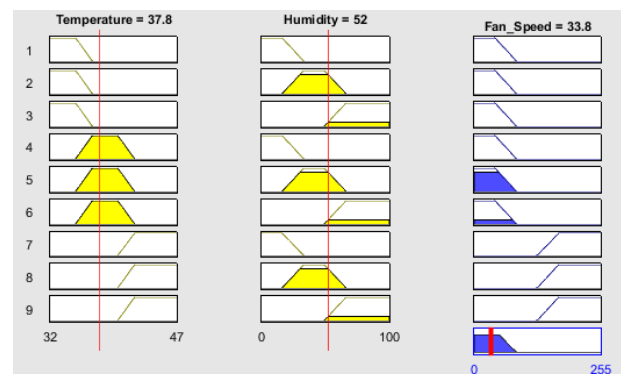

Fig 9. Rule view (optimization/defuzzification results).

E. Egg Inserting Process and Egg Viewing

After designing and manufacturing the control system has been successful done, then the next step is to test the work of the tool. Figure 10 shows the process of inserting eggs for testing hatching.

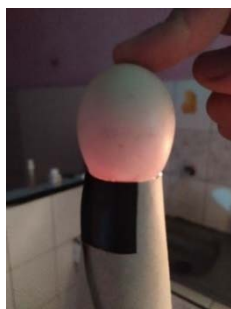

Fig 10. Egg insertion process.

The eggs that are put into the hatching machine are 19 eggs inserted simultaneously. After the egg insertion process on the day the 17th performed manual observation of a fertile egg and infertile. After observation, the infertile eggs were found as many as 10 items. In the process of selecting eggs for the hatching process really good quality eggs are needed. Figure 11 (a) is a fertile egg and Figure 7 (b) is an infertile egg.



(a)



(b)

Fig 11. Fertile and infertile eggs.

Based on the day the 23 eggs that hatch are 2 pieces and the condition of the children the chickens died because after being examined the chicks were unable break the eggshell so that the chick dies and needs our help in the hatching process and egg selection requires really high quality eggs (egg

fertile) the success rate is for the implementation incubator is 47.36%.

IV. CONCLUSION

Based on the explanation above, we can conclude The Implementation of Mamdani's Fuzzy Model for Controlling the Temperature of Chicken Egg Incubator on the results of manual calculations for example cases of temperature 37.8°C and humidity 52% is 33.070 PWM, meanwhile with simulation toolbox calculations obtained 33.8 PWM and on the implementation of the tool obtained 51 PWM Mamdani's fuzzy logic control performance in this chicken egg incubator works good enough, so that it can be used by farmers on a small scale or big.

REFERENCES

- [1] Sofyan Shafiudin and N Kholis, "Monitoring System and Temperature Controlling PID Based Poultry Hatching Incubator," IOP Conf. Ser. Mater. Sci. Eng., p. 1, 2018.
- [2] H. H. . R. Erwin Fadhila, "Pengendalian Suhu Berbasis Mikrokontroler Pada Ruang Penetas Telur," J. Reka Elkomika, vol. 2, no. 4, p. 3, 2014.
- [3] N. Y. D. S. Ika Larasati, "Sistem Kendali Suhu Penetas Telur Ayam Berbasis Java Dan Fuzzy Logic Control," Simetris, vol. 10, no. 1, p. 127, 2019.
- [4] A. . Okpagu, P.E and Nwosu, "Development and Temperature Control of Smart Egg Incubator System for Various Types of Egg," Eur. J. Eng. Technol., vol. 4, p. 13, 2016.
- [5] L. C. Wellington Makondo, Gladman Jekese, Kudzanayi Chiteka, "Mamdani Inference Technique for prediction of egg hatching parameters of different species of birds," in EuropeanAllianceforInnovation(EAI), 2017, p. 493.
- [6] A. T. R. nd M. M. Ammar A. Aldair, "Design and Implementation of Intelligent Control System for Incubator Based on IoT Technology," in Internasional Conference on Electrical, Electronics and System Engineering, 2018, p. 49.
- [7] E. N. I. I. Nwankwo Nonso Prince, "Application of Fuzzy Logic Control in Design and Implementation of Digital Egg Incubator," Int. J. Comput. Sci. Technol., vol. 2, p. 161, 2011.
- [8] N. I. Ismail Yusuf, Yusram Yusuf, "FGA Temperature Control for Incubator Egg," Hindawi Publ. Corp., vol. 2012, pp. 1–8, 2011.
- [9] A. N. M. Noor Yulita Dwi Setyaningsih, "Optimalisasi Posisi Heater Dan Cooler Terhadap Perubahan Kondisi Suhu Pada Inkubator Tetas Penetas Telur," Simetris, vol. 10, no. 1, p. 282, 2019.
- [10] R. D. N. Sunarsan Sitohang, "Fuzzy Logic Untuk Menentukan Penjualan Rumah Dengan Metode Mamdani (Studi Kasus: PT Gracia Herald)," ISD, vol. 2, p. 92, 2017.
- [11] Y. A. L. D. L. Rahakbauw, F. J. Rianekuay, "Penerapan metode fuzzy mamdani untuk memprediksi jumlah produksi karet (studi kasus : data persediaan dan permintaan produksi karet pada PTP nusantara XIV (PERSERO) Kebun Awaya, Teluk Elpaputih, Maluku-Indonesia)," J. Ilm. Mat. dan Terap., vol. 16, p. 120, 2019. G. Eason, B. Noble, and I. N. Sneddon, "On certain integrals of Lipschitz-Hankel type involving products of Bessel functions," Phil. Trans. Roy. Soc. London, vol. A247, pp. 529–551, April 1955. (references)