



# A diode laser system for heating minerals for (U-Th)/He chronometry

**Jurgen P. T. Foeken**

*Isotope Geosciences Unit, SUERC, Scottish Enterprise and Technology Park, Rankine Avenue, East Kilbride G75 0QF, United Kingdom (j.foeken@suerc.gla.ac.uk)*

*Department of Geographical and Earth Sciences, University of Glasgow, Glasgow G12 8QQ, United Kingdom*

**Finlay M. Stuart**

*Isotope Geosciences Unit, SUERC, Scottish Enterprise and Technology Park, Rankine Avenue, East Kilbride G75 0QF, United Kingdom*

**Katherine J. Dobson**

*Department of Geographical and Earth Sciences, University of Glasgow, Glasgow G12 8QQ, United Kingdom*

**Cristina Persano**

*Isotope Geosciences Unit, SUERC, Scottish Enterprise and Technology Park, Rankine Avenue, East Kilbride G75 0QF, United Kingdom*

*Department of Geographical and Earth Sciences, University of Glasgow, Glasgow G12 8QQ, United Kingdom*

**David Vilbert**

*Isotope Geosciences Unit, SUERC, Scottish Enterprise and Technology Park, Rankine Avenue, East Kilbride G75 0QF, United Kingdom*

[1] We have developed a diode laser (25 W, 808 nm) system for He extraction from minerals for (U-Th)/He chronometry. The laser beam is delivered via a 600  $\mu\text{m}$  fiber cable and focused using a binocular microscope. Temperatures necessary for He release from apatite (500–600°C) and zircon (1100–1300°C) encapsulated in Pt-foil tubes are attained by heating to 0.5 W for 30 s and 1.25–2.5 W for 20 min, respectively, using a defocused beam. Heating at these powers does not result in measurable U and/or Th loss from apatite, as noted by the preservation of the distinct Th/U in multiple splits of two different Durango apatite crystals. Analyses of Durango and the California Institute of Technology internal standard apatite 97MR22 yield (U-Th)/He ages of  $32.8 \pm 1.8$  Ma ( $1\sigma$ ,  $n = 11$ ) and  $4.6 \pm 0.5$  ( $1\sigma$ ,  $n = 5$ ), respectively, well within accepted ages. The (U-Th)/He age and Th/U of five Fish Canyon Tuff zircon aliquots yield  $29.3 \pm 2.2$  Ma ( $1\sigma$ ) and  $0.6 \pm 0.03$ , respectively, and are indistinguishable from ages produced by resistance furnace He extraction. Heating of unencapsulated minerals shows that the diode laser couples well with optically opaque minerals (e.g., hornblende, biotite, muscovite, garnet) and basalt groundmass, suggesting that diode lasers offer a cheap, small, low-maintenance alternative to Nd:YAG and Ar ion lasers for  $^{40}\text{Ar}/^{39}\text{Ar}$ , cosmogenic noble gas, and stable isotope studies.

**Components:** 5075 words, 3 figures, 1 table.

**Keywords:** laser methods; (U-Th)/He dating; low-temperature thermochronology; apatite; zircon; helium.

**Index Terms:** 1140 Geochronology: Thermochronology; 1194 Geochronology: Instruments and techniques; 1115 Geochronology: Radioisotope geochronology; 8175 Tectonophysics: Tectonics and landscape evolution; 1041 Geochemistry: Stable isotope geochemistry (0454, 4870).



Received 18 November 2005; Revised 27 January 2006; Accepted 21 February 2006; Published 27 April 2006.

Foeken, J. P. T., F. M. Stuart, K. J. Dobson, C. Persano, and D. Vilbert (2006), A diode laser system for heating minerals for (U-Th)/He chronometry, *Geochem. Geophys. Geosyst.*, 7, Q04015, doi:10.1029/2005GC001190.

## 1. Introduction

[2] The use of lasers as micro-heating and ablation tools in geochemistry has a long history [e.g., *Megrue*, 1967]. Lasers are now routinely used for, among other techniques,  $^{40}\text{Ar}/^{39}\text{Ar}$  chronology [e.g., *Kelley*, 2002, and references therein], stable isotopes [e.g., *Fallick et al.*, 1992; *Smalley et al.*, 1989], and noble gas isotope geochemistry [*Stuart et al.*, 1999] as well as ablation tools for ICP-MS [e.g., *Sylvester*, 2001].

[3] In recent years the (U-Th)/He chronometer has proved as a powerful tool for reconstructing crustal exhumation histories [e.g., *Ehlers and Farley*, 2003; *Farley*, 2002; *Wolf et al.*, 1997]. Although resistance furnaces are routinely used for helium extraction [e.g., *Crowhurst et al.*, 2002; *Foeken et al.*, 2003; *Lorencak et al.*, 2004; *Persano et al.*, 2002; *Stockli et al.*, 2002; *Wolf et al.*, 1997] recently laser heating has been developed [e.g., *House et al.*, 2000; *Reiners et al.*, 2002, 2003]. Lasers have several advantages over furnaces for helium extraction;  $^4\text{He}$  blank levels are lower, background levels of interfering species are lower, and extraction times are faster. This provides the ability to analyze younger and smaller samples, thus alleviating some of the limitations (e.g., poor age reproducibility) of analyzing multigrain samples.

[4] Early experiments aimed at direct heating of crystals showed that at laser powers sufficient to fully outgas mineral grains, U and/or Th were lost, probably by volatilization [*Reiners and Farley*, 1999; *Stuart and Persano*, 1999]. The development of micro-encapsulation of crystals in thermally conductive, refractory metals such as Pt and Nb foil has allowed infra-red (IR) lasers, in particular Nd:YAG, to be used for He extraction from apatite and zircon [*House et al.*, 2000; *Reiners et al.*, 2002, 2003].

[5] Here we report the development of a 808 nm diode laser system for helium extraction from minerals for (U-Th)/He chronometry. A diode laser is a solid-state laser with an optical pumping

system that uses a laser diode instead of a flashlight applied in conventional solid-state lasers (S. M. Goldwasser, A practical guide to lasers for experimenters and hobbyists, version 7.5, 2005; available at <http://repairfaq.ece.drexel.edu/sam/lasersam.htm>) (hereinafter referred to as Goldwasser, 2005). Diode lasers have several advantages for mineral heating and ablation over the equivalent visible/near-IR lasers (Ar ion (460–540 nm) and Nd:YAG (1064 nm)). They are compact, air-cooled, and inexpensive to purchase and maintain (average diode life-time is approximately 10,000 hours). Importantly, the fraction of electrical power converted to optical output is high (>50%) compared to Ar ion (0.001–0.2%) and Nd:YAG lasers (1–4%) (Goldwasser, 2005).

[6] In this study, we describe the diode laser system and show the results of age determinations of laser-heated apatites and zircons. Furthermore, we report preliminary results of heating hornblende, mica, garnet, sanidine, feldspar and quartz, in order to assess its potential as a micro-heating tool for noble gas (in particular  $^{40}\text{Ar}/^{39}\text{Ar}$ ) and stable isotope studies.

## 2. Description of the Diode Laser Extraction System

[7] The primary power supply is a 25 W continuous wave fiber-coupled diode laser (FDL25: Laser-vall S.p.A., Donnas (Aoste), Italy) emitting at a wavelength of 808 nm. Laser radiation is generated by optical pumping in a diode laser cell, housed in a  $54 \times 45 \times 18$  cm metal enclosure (Figure 1a). The FDL25 is equipped with a laser beam-reshaping module that focuses the beam into a 3 m long, 600  $\mu\text{m}$  diameter single-core fiber optic cable (Figure 1a).

[8] Laser power output is linearly correlated with input power at least up to 12.5 W (Figure 2). In particular the linearity extends to output powers less than 2.5 W that are routinely used for He extraction from encapsulated apatite and zircon. This contrasts with Nd-YAG lasers which show nonlinear power output [*Fallick et al.*, 1992].

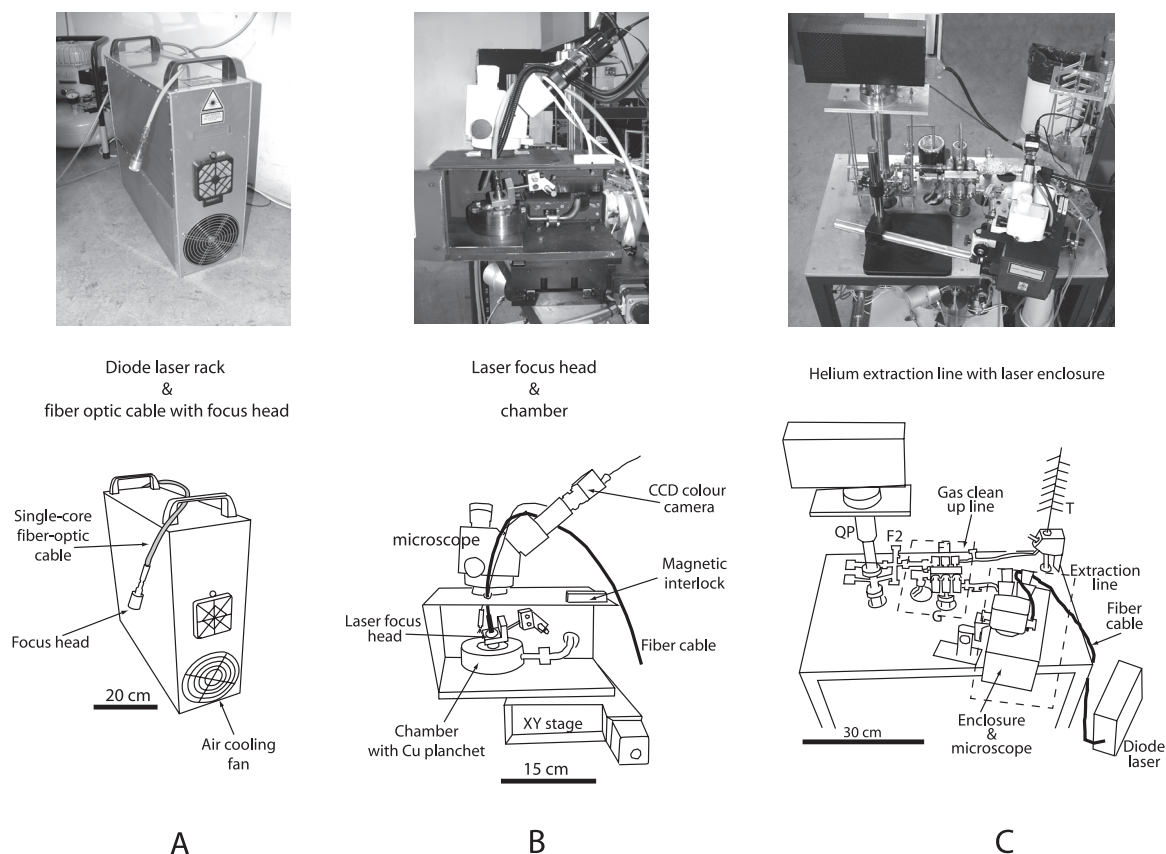
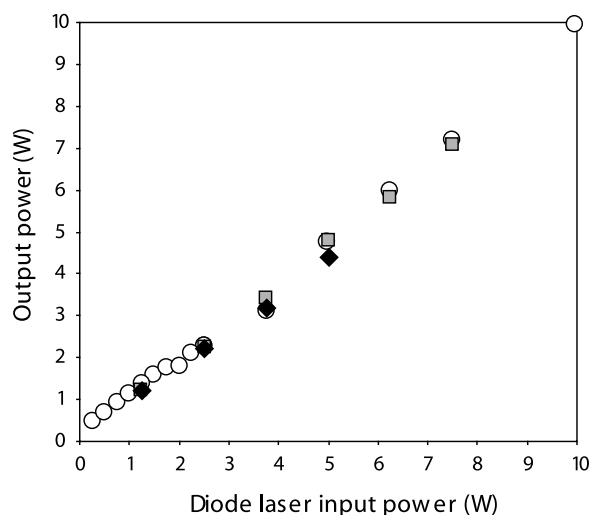

**Figure 1.** (a) Photo plus schematic drawing of the diode laser rack with the 600  $\mu\text{m}$  diameter single-core fiber optic cable and focus head. Dimensions of the laser rack are  $54 \times 45 \times 18$  cm. (b) Photo plus schematic drawing of the fiber cable with focus head mounted on a binocular microscope. Also visible are the enclosure and laser chamber holding the Cu planchet in which samples are loaded. (c) Photo plus schematic drawing of the SUERC helium line. Visible are the diode laser extraction system, the gas cleanup line, and Hiden Quadrupole mass spectrometer. QP, Hiden Analytical Quadrupole; G, SAES getter; F1 and F2, liquid nitrogen cooled charcoal finger; T, glass tree used for loading samples in resistance furnace.

[9] A 5 mW, 632 nm red He-Ne laser runs in the core and the outer  $\sim 100$   $\mu\text{m}$  of the fiber and is used for focusing the 808 nm beam. The fiber cable ends in a  $2 \times 3$  cm focus head (Figure 1a) containing two 18 mm diameter BK7 glass lenses. The first lens collimates the divergent beam exiting the fiber cable. The second lens has a 4 cm focal distance and focuses the beam onto samples. The focus head is externally mounted on a binocular microscope, such that the focal distance is approximately 3.5 cm (Figure 1b) at approximately  $30^\circ$  from the vertical. A color CCD camera ( $752 \times 582$  pixels) is mounted in the eyepiece of the microscope for navigation and monitoring targets during heating by the laser ( $25 \times$  magnification). Leakage of a fraction of the 808 nm radiation into the CCD camera over-saturates the CCD chip, which obscures the view of the target. Two 32 mm

diameter IR filter glasses (Schott KG5) mounted in the eyepiece in front of the camera removes this interference.

[10] Samples are loaded in 1.5 mm deep  $\times$  2 mm diameter holes in a 6 cm diameter high-purity Cu planchet that sits in a 11.5 cm diameter stainless steel chamber (Figure 1b). A 5.3 cm diameter, 1 cm thick sapphire viewport is used to minimize diffusion of atmospheric He. The laser chamber is mounted onto a motorized microscope stage that can be moved in  $x$ - $y$  direction using a joystick. The chamber is connected to the gas cleanup and analysis system by a flexible steel tube, and the system is pumped to  $< 10^{-9}$  torr by a combination of turbo-molecular and triode ion pumps. The laser chamber and focus head are completely enclosed by a  $30 \times 15 \times 15$  cm Al box with magnetic interlock to the laser power supply (Figures 1b



**Figure 2.** Correlation of diode laser input power versus output power. Diode laser power output (measured from a power meter) is linearly correlated with input power even at output powers less than 2.5 W. Power linearity is observed for different beam and focus settings: open circles represent fully focused laser beam, gray squares represent a defocused collimated beam, and solid diamonds represent a focused, collimated beam.

and 1c). Laser power control is provided by in-house written VisualBasic software.

### 3. Analytical Procedures

#### 3.1. Laser Heating

[11] Calibration of the diode laser as a heat source for He extraction was conducted by analyzing multiple aliquots of two 150–180  $\mu\text{m}$  fragments of Durango apatite loaded in  $1 \times 1.5$  mm Pt-foil tubes (0.025 mm thick, 99.99% pure). The aim is to indirectly heat the crystals to temperatures sufficient to quantitatively diffuse out the He, but not melt the crystal [House *et al.*, 2000]. The temperature of the Pt foils are not measured directly during heating, but are assessed by visual observation of the color emitted from heated Pt tubes. An initial temperature calibration has been obtained by heating Pt tubes loaded with Al-foil (melt temperature ( $t_m$ ) = 660°C) and Ag wool ( $t_m$  = 960°C). Melting of the Al-foil and Ag wool occurred at approximately 0.6 and 0.8 W, respectively, using a defocused beam of 3 mm diameter spot size. By varying the heating duration and laser power (see section 4) we have determined that complete degassing of apatite fragments and crystals requires heating for 30 s at 500–600 °C (0.5 W,

using the defocused beam). Reheating the sample under the same conditions releases no additional He above blank levels. The short heating time compares favorably to the 40 min heating required with the conventional furnace. The estimated laser temperatures are lower than commonly used in resistance furnace heating for helium extraction (approximately 950°C [e.g., Crowhurst *et al.*, 2002; Foeken *et al.*, 2003; Lorencak *et al.*, 2004; Persano *et al.*, 2002; Stockli *et al.*, 2002; Wolf *et al.*, 1997]), but compare to temperatures at which complete helium extraction was obtained during diffusion experiments on the Durango apatite [Wolf *et al.*, 1996; Zeitler *et al.*, 1987]. The differences in heating temperatures likely result from poor thermal coupling in the furnace compared to laser heating, in which coupling is instantaneous.

[12] Complete He extraction from 80–100  $\mu\text{m}$  diameter Fish Canyon Tuff zircons is achieved by 20 min heating at 1.25 – 2.5 W with a defocused beam. This corresponds to a temperature of 1100–1300°C based on optical pyrometry. Ongoing experiments on Fish Canyon Tuff titanites show that heating for 5 to 10 min at approximately 1200 °C results in complete helium extraction from the titanites.

[13] Small variation in the degree to which individual Pt foil packets couple with the beam has been observed and probably relates to packet orientation. The homogeneous incandescence of heated Pt-foil packets suggests that the shadow effect produced by the incidence angle of the laser beam has a negligible effect on heating encapsulated minerals. Good coupling is also achieved with Nd-foil packets.

#### 3.2. He, U, and Th Analysis Procedures

[14] Prior to analysis the laser chamber and connecting flexi-tube is degassed at approximately 100°C for 1 hour, which reduces background H, CH<sub>4</sub> and H<sub>2</sub>O levels by 2–3 times. Gases liberated by heating the Pt-foil capsules are purified using a hot SAES TiZr getter and two liquid nitrogen-cooled charcoal traps (Figure 1c). <sup>4</sup>He abundances along with <sup>3</sup>He, H (mass 2) and CH<sub>4</sub> (mass 16), are determined by an electron multiplier in a Hiden HAL3F quadrupole mass spectrometer operated in static mode. Absolute He concentrations are calculated from peak height comparison against a calibrated standard. Discontinuing <sup>3</sup>He-spike measurements [Balestrieri *et al.*, 2005; Persano *et al.*, 2002] avoids residual <sup>4</sup>He in the <sup>3</sup>He-spike, result-



**Table 1.** He, U, and Th Data for Diode Laser Heating of Durango Apatite, British Columbia Apatite 97MR22, and Fish Canyon Tuff Zircon

Sample	<sup>4</sup> He, cc STP	U <sup>238</sup> , ng	Th <sup>232</sup> , ng	Th/U	Error	Age, Ma	Error	Ft	Corrected Age, Ma	Error	Comments <sup>a</sup>
<i>Durango Apatite</i>											
VU Dur 30 <sup>b</sup>	3.30E-09	0.01	1.90	156.8	7.2	58.7	2.7				5 W; beam in focus
VU Dur 31 <sup>b</sup>	3.41E-09	0.02	3.01	130.3	2.8	38.1	0.8				5 W; beam in focus
VU Dur 32	3.00E-09	0.11	2.74	24.3	0.5	32.4	0.6				0.25 W; beam in focus
VU Dur 33 <sup>b</sup>	2.10E-09	0.02	1.93	80.1	2.7	36.0	1.2				5 W; beam in focus
VU Dur 34 <sup>b</sup>	1.70E-08	0.02	3.22	138.0	2.6	37.7	0.7				0.25 W; beam in focus
VU Dur 35	3.98E-09	0.16	3.74	23.2	0.4	31.3	0.5				1.25 W
VU Dur 36	2.02E-09	0.07	1.79	24.8	0.5	33.5	0.7				1.25 W
VU Dur 37	3.35E-09	0.16	3.45	21.5	0.4	28.2	0.5				2.5 W
VU Dur 38	3.35E-09	0.13	3.00	22.6	0.4	32.8	0.6				0.25 W
VU Dur 39 <sup>b</sup>	4.64E-09	0.13	4.19	32.5	0.8	34.1	0.9				0.25 W; beam in focus
VU Dur 40	3.26E-09	0.13	2.75	20.5	0.4	34.2	0.6				0.5 W
VU Dur 41	3.23E-09	0.13	2.71	20.4	0.3	34.3	0.6				0.5 W
VU Dur 42	4.29E-09	0.17	3.67	21.6	0.4	34.0	1.1				1.25 W
<b>Average laser-heated</b>				<b>22.4</b>	<b>1.7</b>	<b>32.6</b>	<b>2.0</b>				
<i>Average furnace-heated (n = 11)<sup>c</sup></i>				<i>22.9</i>	<i>2.2</i>	<i>32.8</i>	<i>1.3</i>				
CIT Dur 86	4.88E-09	0.22	4.14	18.9	0.4	33.6	0.8				0.5 W
CIT Dur 87	4.10E-09	0.19	3.41	17.8	0.3	33.8	0.6				0.5 W
CIT Dur 88	8.35E-09	0.38	7.23	19.2	0.4	32.9	0.7				0.5 W
<b>Average laser-heated</b>				<b>18.6</b>	<b>0.7</b>	<b>33.4</b>	<b>0.5</b>				
<i>Average furnace-heated (n = 11)<sup>c</sup></i>				<i>18.8</i>	<i>1.5</i>	<i>31.9</i>	<i>2.0</i>				
<b>All laser-heated Durango</b>						<b>32.8</b>	<b>1.8</b>				
<b>All furnace-heated Durango</b>						<b>32.3</b>	<b>0.9</b>				
<i>British Columbia Apatite (CIT)<sup>d</sup></i>											
97MR22-1	3.36E-11	0.08	0.06	0.8	0.02	3.1	0.68	4.6	0.1		2 crystals, 0.5 W
97MR22-2	1.03E-10	0.20	0.09	0.4	0.01	3.8	0.84	4.5	0.1		single crystal, 0.5 W
97MR22-3	2.41E-11	0.05	0.05	1.0	0.03	3.2	0.77	4.2	0.1		single crystal, 0.5 W
97MR22-4	3.68E-11	0.09	0.07	0.8	0.01	2.9	0.67	4.3	0.1		2 crystals, 0.5 W
97MR22-5	1.27E-10	0.23	0.15	0.7	0.01	4.0	0.75	5.4	0.1		3 crystals, 0.5 W
<b>Average laser-heated</b>				<b>0.7</b>	<b>0.2</b>			<b>4.6</b>	<b>0.5</b>		
<i>Fish Canyon Tuff zircon</i>											
FCT-1	1.17E-08	4.13	2.51	0.6	0.01	20.3	0.76	26.8	0.5		2 crystals, 2 W
FCT-2	4.31E-09	1.67	1.05	0.6	0.01	18.5	0.64	29.1	0.6		2 crystals, 1 W
FCT-3	5.76E-09	2.02	1.11	0.6	0.01	20.7	0.63	33.0	0.7		2 crystals, 2.5 W
FCT-4	1.15E-08	4.08	2.38	0.6	0.01	20.2	0.71	28.6	0.6		2 crystals, 2.5 W
FCT-5	9.50E-09	3.32	1.82	0.6	0.01	20.6	0.70	29.3	0.6		2 crystals, 2.5 W
<b>Average laser-heated</b>				<b>0.6</b>	<b>0.03</b>			<b>29.3</b>	<b>2.2</b>		
<b>Average furnace-heated<sup>c</sup></b>				<b>0.6</b>	<b>0.10</b>			<b>27.7</b>	<b>2.7</b>		

<sup>a</sup>Maximum laser power (W) to which sample was heated. A defocused beam was used for He extraction unless stated.

<sup>b</sup>Not taken into account for average because laser Durango Th/U ratio is outside furnace Durango Th/U range; see text for discussion.

<sup>c</sup>SUERC database, unpublished data.

<sup>d</sup>California Institute of Technology (CIT) internal standard [House et al., 2000].

ing in lower <sup>4</sup>He blank levels which are required for analysis of single grains or very young samples. The precision of He measurements is determined by repeated measurements of the <sup>4</sup>He standard. Within-day reproducibility of measurement of the <sup>4</sup>He standard is better than 0.4% (1σ, n = 27). For the longer-term reproducibility of standard measurements (March–June 2005) the precision of He

measurements is approximately 0.8%. Laser heating of empty Pt tubes yields He blank levels that are at system background levels (1.5 × 10<sup>-12</sup> ± 0.2 cc STP, n = 33) and indistinguishable from other laser systems [cf. House et al., 2000]. Following helium extraction the Pt tubes with apatite are transferred into Teflon beakers and prepared for U and Th analysis by inductively coupled plasma

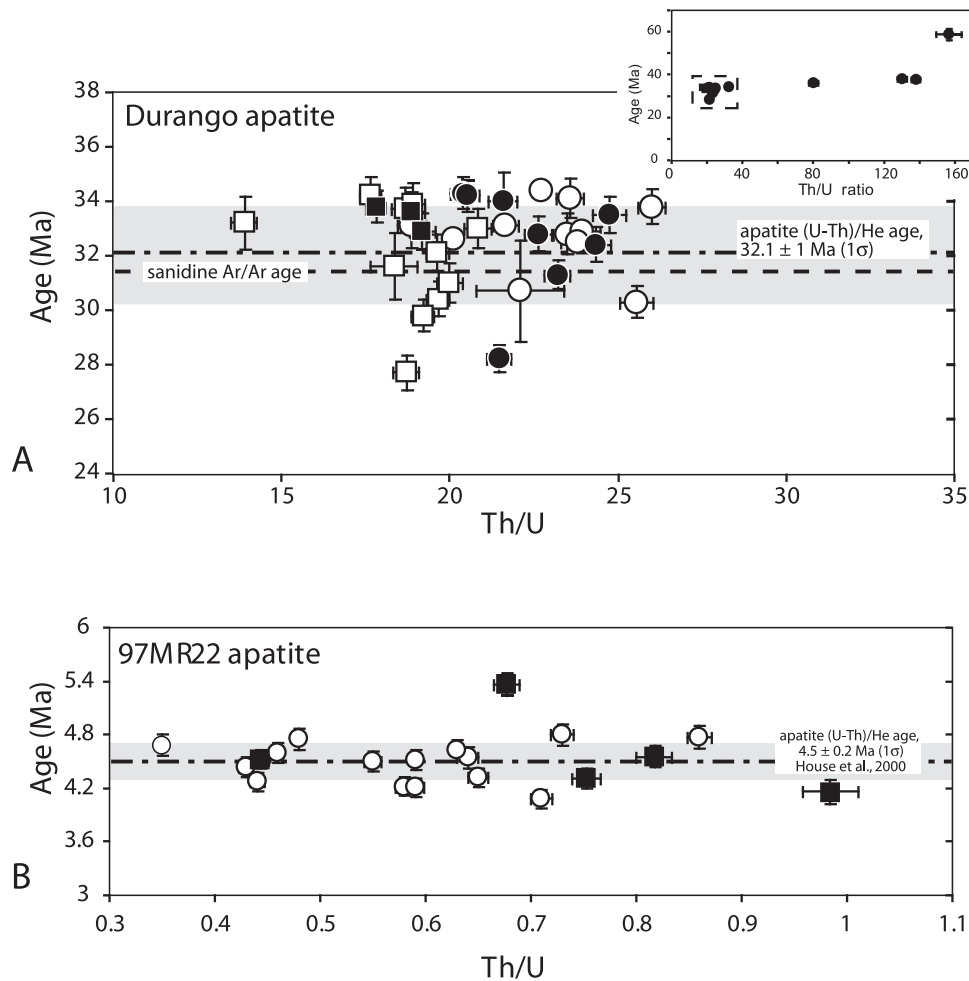

**Figure 3.** Plot of apatite and zircon (U-Th)/He ages versus Th/U. (a) Durango apatite. Circles represent Vrije Universiteit (VU) Durango; squares are California Institute of Technology (CIT) Durango. Filled symbols represent diode laser extractions, and the open symbols are resistance furnace ages. Gray band is mean laser Durango apatite He ages of *House et al.* [2000] ( $32.1 \pm 1.7$  Ma ( $1\sigma$ ,  $n = 11$ )); dashed line is single grain sanidine  $^{40}\text{Ar}/^{39}\text{Ar}$  age [*McDowell et al.*, 2005]. (b) 97MR22 British Columbia apatite (CIT internal standard [*House et al.*, 2000]). Black squares are diode laser heated samples (single to 3 grain aliquots); open circles are single grain and multigrain data of *House et al.* [2000].

mass spectrometry following *Balestrieri et al.* [2005]. Dissolution chemistry for zircon follows the procedure of *Dobson et al.* [2005]. The Pt tubes contain traces of U and Th which is leached out during the apatite dissolution ( $\sim 0.007$  ng U and  $\sim 0.02$  ng Th). Consequently, for the 97MR22 apatite samples (section 4) blank corrections were made. Further experiments have shown that this U and Th can be removed by leaching empty Pt tubes in 5% nitric acid for 24 hours prior to laser heating. U and Th blank corrections for zircon chemistry are higher ( $\sim 0.1$  ng U and Th) as the Pt tubes are dissolved during the process. In Table 1 the  $1\sigma$  analytical errors in the (U-Th)/He ages are propa-

gated from analytical uncertainties on U, Th and He concentrations.

## 4. Results of Laser Heating

### 4.1. Apatite

[15] The U, Th and He data from the laser heating experiments of Durango apatite are reported in Table 1 and plotted in Figure 3a. Two fragments of different Durango apatite [*Young et al.*, 1969] crystals supplied by the California Institute of Technology (CIT) and Vrije Universiteit, Amsterdam (VU) were analyzed, as we have previously noted a subtle difference in their Th/U.



[16] An initial series of analyses were aimed at determining an appropriate extraction time and temperature for He extraction. In particular we sought to avoid volatilization of U and Th due to over-heating, which is recorded by a fractionation of Th/U [e.g., *Stuart and Persano*, 1999]. The loss of U and/or Th results in increased He ages [*House et al.*, 2000]. Five samples of VU Durango apatite (VU Dur 30, 31, 33, 34 and 39) were heated to temperatures up to 1700°C (the melting point of Pt) using different laser focusing configurations. These samples yielded Th/U in the range 32.5 to 156.8 (Figure 3a, inset) that are outside the range obtained for furnace heating. Four of the five samples yielded He ages that are older than the range recorded by furnace extraction (36.0 to 58.7 Ma) and indicate that preferential loss of U has occurred during heating.

[17] VU Durango apatites heated by laser to approximately 600°C yield a mean Th/U ( $22.4 \pm 1.7$ ,  $n = 8$ ) that is indistinguishable from those obtained by furnace extraction ( $22.9 \pm 2.2$ ,  $n = 11$ ). The mean He age of these laser-heated apatite ( $32.6 \pm 2.0$  Ma) is indistinguishable from the He age determined using furnace extraction ( $32.8 \pm 1.3$  Ma; Table 1). Three CIT Durango apatites analyzed in the same way have Th/U ( $18.6 \pm 0.7$ ) that are indistinguishable from the value for resistance furnace heated samples ( $18.8 \pm 1.5$ ,  $n = 11$ ). The mean He age ( $33.4 \pm 0.5$  Ma) also overlaps the range recorded by furnace extraction ( $31.9 \pm 2.0$  Ma,  $n = 11$ ). The mean He age of all the laser-heated Durango apatite samples ( $32.8 \pm 1.8$  Ma,  $n = 11$ ) compares well with the equivalent value reported by CIT ( $32.1 \pm 1.7$  Ma ( $n = 11$ ) [*House et al.*, 2000]). The Th/U of all samples are within the range determined by LA-ICP-MS (17.8–27.7) reported by *Boyce and Hodges* [2005]. Importantly, our heating schedule has preserved the systematic difference in the Th/U between CIT and VU Durango apatite, attesting to the complete retention of U and Th during laser heating to 600°C.

[18] Five aliquots of 1 to 3 grains of 97MR22 British Columbia apatites (CIT internal standard [*House et al.*, 2000]) were carefully handpicked to ensure inclusion-free grains and laser heated following the Durango heating schedule (Table 1 and Figure 3b). The Th/U ( $0.7 \pm 0.2$ ,  $1\sigma$ ) and (U-Th)/He age ( $4.6 \pm 0.5$  Ma,  $1\sigma$ ) of those samples are indistinguishable to those reported by *House et al.* [2000] ( $0.6 \pm 0.1$  and  $4.5 \pm 0.2$ , respectively,  $n = 15$ ). Of the diode laser heated samples, 97MR22-5 (3 grains) yielded a (U-Th)/He age which is slightly

older than the single and two grain samples. This indicates one of the hazards associated with multigrain samples. The low He blanks obtained with laser heating allow the analysis of single grain aliquots, which, often, is not achievable with furnace heating.

#### 4.2. Zircon

[19] U, Th and He data for five, 2–3 grain aliquots of Fish Canyon Tuff zircon are reported in Table 1. The Th/U for these aliquots are  $0.6 \pm 0.03$ , which are within the ranges obtained from resistance furnace heating at SUERC ( $0.6 \pm 0.1$ ,  $n = 14$ ,  $1\sigma$ ) and published values ( $0.6 \pm 0.1$  ( $1\sigma$ ) [*Reiners*, 2005]). (U-Th)/He ages ( $29.3 \pm 2.2$ ,  $1\sigma$ ) are also indistinguishable from those obtained from furnace heating ( $27.7 \pm 2.7$ ,  $n = 14$ ,  $1\sigma$ ) and published values ( $28.3 \pm 2.6$  ( $1\sigma$ ,  $n = 83$ ) [*Reiners*, 2005]). These results provide further confirmation of the utility of the diode laser for He extraction for (U-Th)/He chronometry.

### 5. Future Applications for Isotope Studies

[20] To test the potential of the diode laser for other noble gas and stable isotope applications we have determined how the laser couples with unencapsulated crystals and rock fragments. Coupling proved to be best for opaque (Fe-bearing) crystals (hornblende, biotite, phlogopite, and garnet) as well as dacite and basalt groundmass fragments. Heating and partial melting occurs near-instantaneously at less than 5 W using a beam defocused to 3 mm spot diameter. Coupling with muscovite, plagioclase, and semi-transparent sanidine requires laser power of 5–10 W to initiate melting and typically occurs at less than 30 s heating time. Heating of near-transparent sanidine and quartz does not significantly heat the grains even at in excess of 20 W. However, the addition of ~150 mg degassed basalt glass powder to 1 g of 250–500  $\mu\text{m}$  quartz grains proved enough to allow the transparent mineral to be heated to more than 1500°C and initiate melting.

[21] These results show that the 808 nm diode laser couples with minerals in a manner similar to other visible and near-infra red lasers (e.g., Nd:YAG and Ar ion) and indicate that it will make a suitable micro-heating tool for  $^{40}\text{Ar}/^{39}\text{Ar}$  chronology, cosmogenic noble gas and stable isotope investigations. The small size and low power requirements make the diode laser a possible gas extraction tool



for use on planetary landers. The fiber diameter used in the SUERC laser system limits the focused beam diameter to a theoretical minimum of 600  $\mu\text{m}$ , restricting its use for high spatial resolution in situ studies [e.g., Smalley *et al.*, 1989]. However, the use of smaller fiber diameters will further increase the applicability of the technique.

## 6. Conclusions

[22] A fiber-delivered 25 W, continuous wave 808 nm diode laser is used for helium extraction for (U-Th)/He chronology. Laser heating of microencapsulated Durango apatite fragments yield ages ( $32.8 \pm 1.8$  Ma;  $n = 11$ ) which are indistinguishable to those obtained by furnace heating ( $32.3 \pm 0.9$  Ma;  $n = 22$ ). (U-Th)/He ages of laser heating of a natural apatite from British Columbia (97MR22) yields an age of  $4.6 \pm 0.5$  Ma, well within previous reported ages for this mineral. Five laser-heated Fish Canyon Tuff zircon aliquots yield ages and Th/U ( $29.3 \pm 2.2$ , ( $1\sigma$ ) and  $0.6 \pm 0.03$ , respectively) that are indistinguishable from resistance furnace heated ages. Lasing unencapsulated crystals and fragments of volcanic rock groundmass indicates that the diode laser is similar in performance of Nd:YAG and Ar-ion lasers. The diode laser has several advantages over these lasers; it is significantly more efficient, small ( $54 \times 45 \times 18$  cm), air-cooled and cheap to purchase and maintain, and therefore has great potential as a micro-heating/ablation tool for future noble gas and stable isotope studies.

## Acknowledgments

[23] J.F. would like to thank Peter Crowhurst and members of the alt.lasers newsgroup for useful discussions on laser physics. Willie Degnan, Terry Donnelly, Dave Gerc, Peter Mellon, Gayle Nicholson, and Andrew Tait are thanked for assistance with construction, and Valerie Olive is thanked for persistence with the ICP-MS. We thank Tibor Dunai and Ken Farley for supplying the minerals used in this study. Peter Reiners (twice) and two anonymous reviewers provided constructive comments that markedly improved the paper. The work was funded by the Carnegie Trust for the Universities of Scotland and the University of Glasgow.

## References

Balestrieri, M. L., F. M. Stuart, C. Persano, E. Abbate, and G. Bigazzi (2005), Geomorphic development of the escarpment of the Eritrean margin, southern Red Sea from combined apatite fission-track and (U-Th)/He thermochronometry, *Earth Planet. Sci. Lett.*, *231*, 97–110.

Boyce, J. W., and K. V. Hodges (2005), U and Th zoning in Cerro de Mercado (Durango, Mexico) fluorapatite: Insights regarding the impact of recoil redistribution of radiogenic

<sup>4</sup>He on (U-Th)/He thermochronology, *Chem. Geol.*, *219*, 261–274.

Crowhurst, P. V., P. F. Green, and P. J. J. Kamp (2002), Appraisal of (U-Th)/He apatite thermochronology as a thermal history tool for hydrocarbon exploration: An example from the Taranaki Basin, New Zealand, *AAPG Bull.*, *86*, 1801–1819.

Dobson, K. J., V. Olive, C. Persano, and F. M. Stuart (2005), A new procedure for the routine zircon (U-Th)/He age measurement, *Geophys. Res. Abstr.*, *7*, Abstract EGU05-A-06696.

Ehlers, T. A., and K. A. Farley (2003), Apatite (U-Th)/He thermochronometry: Methods and applications to problems in tectonic and surface processes, *Earth Planet. Sci. Lett.*, *206*, 1–14.

Fallick, A. E., P. McConville, A. J. Boyce, R. Burgess, and S. P. Kelley (1992), Laser microprobe stable isotope measurements on geological materials: Some experimental considerations (with special reference to  $\delta^{34}\text{S}$  in sulfides), *Chem. Geol.*, *101*, 53–61.

Farley, K. A. (2002), (U-Th)/He dating: Techniques, calibrations and applications, in *Noble Gases in Geochemistry and Cosmochemistry*, *Rev. Mineral. Geochem.*, vol. 47, edited by D. P. Porcelli *et al.*, pp. 819–844, Mineral. Soc. of Am., Washington, D. C.

Foeken, J. P. T., T. J. Dunai, G. Bertotti, and P. A. M. Andriessen (2003), Late Miocene to present exhumation in the Ligurian Alps (southwest Alps) with evidence for accelerated denudation during the Messinian salinity crisis, *Geology*, *31*, 797–800.

House, M. A., K. A. Farley, and D. Stockli (2000), Helium chronometry of apatite and titanite using Nd:YAG laser heating, *Earth Planet. Sci. Lett.*, *183*, 365–368.

Kelley, S. (2002), K-Ar and Ar-Ar dating, in *Noble Gases in Geochemistry and Cosmochemistry*, *Rev. Mineral. Geochem.*, vol. 47, edited by D. P. Porcelli *et al.*, pp. 875–818, Mineral. Soc. of Am., Washington, D. C.

Lorencak, M., B. P. Kohn, K. G. Osadetz, and A. J. W. Gleadow (2004), Combined apatite fission track and (U-Th)/He thermochronometry in a slowly cooled terrane: Results from a 3440-m-deep drill hole in the southern Canadian Shield, *Earth Planet. Sci. Lett.*, *227*, 87–104.

McDowell, F. W., W. C. McIntosh, and K. A. Farley (2005), A precise <sup>40</sup>Ar/<sup>39</sup>Ar reference age for the Durango apatite (U-Th)/He and fission-track dating standard, *Chem. Geol.*, *214*, 249–263.

Megrue, G. H. (1967), Isotopic analysis of rare gases with a laser microprobe, *Science*, *157*, 1555–1556.

Persano, C., F. M. Stuart, P. Bishop, and D. N. Barfod (2002), Apatite (U-Th)/He age constraints on the development of the Great Escarpment on the southeastern Australian passive margin, *Earth Planet. Sci. Lett.*, *200*, 79–90.

Reiners, P. W. (2005), Zircon (U-Th)/He thermochronometry, in *Low-Temperature Thermochronology: Techniques, Interpretations, and Applications*, *Rev. Mineral. Geochem.*, vol. 58, edited by P. W. Reiners and T. A. Ehlers, pp. 151–179, Mineral. Soc. of Am., Washington, D. C.

Reiners, P. W., and K. A. Farley (1999), Helium diffusion and (U-Th)/He thermochronometry of titanite, *Geochim. Cosmochim. Acta*, *63*, 3845–3859.

Reiners, P. W., T. A. Ehlers, J. I. Garver, S. G. Mitchell, D. R. Montgomery, J. A. Vance, and S. Nicolescu (2002), Late Miocene exhumation and uplift of the Washington Cascade Range, *Geology*, *30*, 767–770.

Reiners, P. W., Z. Zhou, T. Ehlers, C. Xu, M. T. Brandon, R. A. Donelick, and S. Nicolescu (2003), Post-orogenic evolution of the Dabie Shan, eastern China, from (U-Th)/He and fission track thermochronology, *Am. J. Sci.*, *303*, 489–518.





- Smalley, P. C., D. E. Stijfhoorn, A. Raheim, H. Johansen, and J. A. D. Dickson (1989), The laser microprobe and its application to the study of C and O isotopes in calcite and aragonite, *Sediment. Geol.*, *65*, 211–221.
- Stockli, D. F., B. E. Surpless, T. A. Dumitru, and K. A. Farley (2002), Thermochronological constraints on the timing and magnitude of Miocene and Pliocene extension in the central Wassuk Range, western Nevada, *Tectonics*, *21*(4), 1028, doi:10.1029/2001TC001295.
- Stuart, F. M., and C. Persano (1999), Laser melting of apatite for (U-Th)/He chronology: Progress to date, *Eos Trans. AGU*, *80*(46), Fall Meet. Suppl., F1169.
- Stuart, F. M., P. J. Harrop, S. Knott, and G. Turner (1999), Laser extraction of helium isotopes from Antarctic micrometeorites: Source of He and implications for the flux of extraterrestrial <sup>3</sup>He to earth, *Geochim. Cosmochim. Acta*, *63*, 2653–2665.
- Sylvester, P. (Ed.) (2001), *Laser Ablation-ICPMS in the Earth Sciences: Principles and Applications*, 243 pp., Mineral. Assoc. of Can., Ottawa, Canada.
- Wolf, R. A., K. A. Farley, and L. T. Silver (1996), Helium diffusion and low-temperature thermochronometry of apatite, *Geochim. Cosmochim. Acta*, *60*, 4231–4240.
- Wolf, R. A., K. A. Farley, and L. T. Silver (1997), Assessment of (U-Th)/He thermochronometry: The low-temperature history of the San Jacinto mountains, California, *Geology*, *25*, 65–68.
- Young, E., A. Myers, E. Munson, and N. Conklin (1969), Mineralogy and geochemistry of fluorapatite from Cerro de Mercado, Durango, Mexico, *U.S. Geol. Surv. Prof. Pap.*, *650-D*, D84–D93.
- Zeitler, P. K., A. L. Herczeg, I. McDougall, and M. Honda (1987), U-Th-He dating of apatite: A potential thermochronometer, *Geochim. Cosmochim. Acta*, *51*, 2865–2868.