

## MASTER

Optimal experiment design of a new minimal model of glucose kinetics during an oral glucose tolerance test

incorporating effects of recruitment of muscle capillaries Glut-4 translocation and hepatic glucose production

Almagro Frutos, S.

*Award date:*  
2006

[Link to publication](#)

### Disclaimer

This document contains a student thesis (bachelor's or master's), as authored by a student at Eindhoven University of Technology. Student theses are made available in the TU/e repository upon obtaining the required degree. The grade received is not published on the document as presented in the repository. The required complexity or quality of research of student theses may vary by program, and the required minimum study period may vary in duration.

### General rights

Copyright and moral rights for the publications made accessible in the public portal are retained by the authors and/or other copyright owners and it is a condition of accessing publications that users recognise and abide by the legal requirements associated with these rights.

- Users may download and print one copy of any publication from the public portal for the purpose of private study or research.
- You may not further distribute the material or use it for any profit-making activity or commercial gain

# Optimal Experiment Design of a New Minimal model of Glucose Kinetics during an Oral Glucose Tolerance Test

Incorporating effects of  
recruitment of muscle capillaries  
Glut-4 translocation and  
hepatic glucose production

by S. Almagro Frutos

Master of Science thesis

Project period: Oktober 2005 – September 2006

Report Number: 06A/10

Research chair: MBS-CS

Commissioned by: Prof. Dr. Ir. P.P.J. van den Bosch (TU/e)  
Prof. Dr. A.J.M. Wagenmakers  
(University of Birmingham, TU/e)

Dr. Ir. N.A.W van Riel (TU/e)

Supervisors: Dr. Ir. N.A.W van Riel (TU/e)

Additional Commission members:

Dr. Ir. A.A.H. Damen (TU/e)

# Optimal Experiment Design of a New Minimal model of Glucose Kinetics during an Oral Glucose Tolerance Test

Incorporating effects of  
recruitment of muscle capillaries  
Glut-4 translocation and  
hepatic glucose production

*S. Almagro Frutos, A.J.M. Wagenmakers, P.P.J. van den Bosch, N.A.W. van Riel*

## Abstract

Investigating glucose kinetics under physiological conditions e.g. a meal or an oral glucose tolerance test (OGTT), is extremely valuable since diabetes mellitus is a pressing public health concern. In this study an expanded version of the glucose minimal model of Bergman has been developed and verified from a physiological and identification point of view using synthetic data produced from parameters found in literature.

In succession of the minimal model presented by [Bergman et al., *Am. J. Phys.* 236: E667-E677, 1979] which is widely used under non-physiological conditions, different minimal models are presented for use under physiological conditions during an OGTT e.g. [Natalucci et al., *Int. Conf. IEEE EMB, Cancun, Mexico, 2003*]. Natalucci's et al. minimal model is expanded to include *jointly* the effects of capillary recruitment, Glut-4 translocation and the production and inhibition of hepatic glucose production. The expanded minimal model incorporates a physiological model of glucose appearance from gut into blood plasma and an interstitial glucose compartment which can be measured using the microdialysis technique.

The new model has been tested in all its identifiability aspects: on a priori global identifiability by using an algorithm based on differential algebra [Audoly et al, *IEEE Trans Biomed.*, 48 1: 55-65, 2001] and a posteriori identifiability using model to model adjustment. Also, the sensitivity of the a priori identifiable parameters in relation with the estimated parameters has been examined showing large sensitivity for two of the six a priori parameters. Parameter estimation has been performed using Maximum likelihood estimation and the worst bias is calculated showing low bias for all estimated parameters. The oral glucose ingestion dosis has been optimised to reduce the bias for the estimated parameters and an algorithm has been designed to find the optimal sample schedule. Knowing the *joint* interaction between these mechanism in a novel, physiologically more detailed model and identifying the new oral glucose minimal model *in all its aspects and* performing optimal experiment design, is a great step forward to understand and quantify different potential causes of insulin resistance in type 2 diabetes.

*Keywords: minimal compartmental model, glucose kinetics, OGTT, capillary recruitment, Glut-4 translocation, saturable receptor-mediated insulin transport, microdialysis, interstitial glucose, a priori global identifiability, a posteriori identifiability, maximum likelihood estimation, optimal experiment design*

## Introduction

### 1 Diabetes Mellitus

Diabetes mellitus is a metabolic disease characterized by varying or persistent elevated glucose levels in blood plasma. Diabetes mellitus is a pressing public health concern. In the Netherlands more than a half million people suffer from diabetes. Diabetes mellitus can be divided into two types: type 1 and type 2. Diabetes type 1 is caused by a lack of insulin

production and insulin secretion by the pancreas and type 2 diabetes is caused by decreased sensitivity of body tissues for insulin. This study focuses on type 2 diabetes.

The glucose regulatory system in humans consists of releasing insulin by the pancreatic  $\beta$  cells when the glucose concentration in blood rises above the normal range of 3.6 to 6.1 mM. Insulin stimulates glucose uptake by skeletal muscle (and adipose tissue) and suppresses glucose production by the liver (hepatic glucose production). Insulin stimulates glucose uptake by skeletal muscle via two sequential mechanisms: recruitment of capillaries surrounding muscle fibers and glucose transporter-4 (Glut-4) translocation.

The second mechanism depends on the access of glucose and insulin to skeletal muscle. Glucose uptake by human skeletal muscle is regulated by insulin concentration in the interstitium [H. Herkner 2003]. Insulin is transported from blood plasma through the endothelium to reach the interstitium. After insulin has reached the interstitium, insulin is cleared due to internalization and degradation of insulin by muscle cells: Insulin binds to the insulin receptor in the interstitium which is the initiating step in insulin signalling pathways as discussed.

Two hypotheses have been proposed for the first mechanism: capillary recruitment and insulin-mediated increase of blood flow [Bergman 2003 and references in there]. In skeletal muscles two vascular flow routes exist: one route by nutritive capillaries that surround the skeletal muscles fibres responsible for the delivery of glucose and insulin and a second route by non-nutritive capillaries that has no contact with the skeletal muscles fibres. The first hypothesis suggests that insulin controls the blood flow to skeletal muscle at rest and during exercise by varying blood flow between the nutritive capillaries and the non-nutritive capillaries. It is believed that this process is very fast, 5 minutes after increase of insulin [Vincent 2004, Iwashita 2001, Porter 1997] and at insulin concentrations lower than required for the second hypothesis [Zhang 2004]. Changes in the distribution pattern can be caused by insulin resistance of the endothelial cells. Several studies [Clerk 2006, Gudbjörnsdóttir 2005, Gudbjörnsdóttir 2003] show an increase of capillary recruitment (increased permeability-surface area product (PS)) during enhanced physiological insulin concentration and a reduced capillary recruitment (lower PS) in type 2 diabetes humans than in healthy (obese) humans. The second hypothesis suggests that insulin acts as a vasodilator (alternating the blood flow at regular intervals through different capillary groups) controlling the access of glucose and insulin to skeletal muscle. Insulin binds to the insulin receptor on the luminal endothelial cells and this activates nitric oxide synthase (NOS). In response, endothelial cells release the vasodilator nitric oxide (NO) that prevents the smooth muscle cells of the precapillary arteriole to contract. This effect is more apparent at higher insulin concentration (pharmacologic concentrations) and after several hours. Impaired vasodilation can be due to insulin resistance. No increase in blood flow is seen during physiological insulin concentrations in obese healthy humans and type 2 diabetic humans [Bergman 2003 and reference in there, Gudbjörnsdóttir 2005, Gudbjörnsdóttir 2003]. However, [Clerk 2006] shows an increase during physiological insulin concentrations in lean healthy humans as well as in obese healthy humans. Insulin resistance can also have a more physical-chemical reason like a highly impermeable endothelium or reduced capillary density.

Several studies have addressed the mechanism of insulin transport from blood plasma through the endothelium to reach the interstitium by measuring glucose and insulin concentrations in blood plasma and interstitium. These studies result in conflicting conclusions either diffusion transport or a saturable receptor-mediated transport. These conflicting results have been analysed here (appendix A). It is concluded that a saturable

receptor-mediated insulin transport is considered when insulin concentrations are in a physiological range (up to 600 pM) whereas a non-saturable insulin transport is considered at pharmacologic insulin concentrations (++ 600 pM).

The second mechanism by which insulin stimulates glucose clearance is by increased uptake by myocytes. The transport of glucose through the muscle cell membrane is facilitated by a special carrier mediated protein called Glut-4. In the early morning fasting state only a small portion of the total amount of Glut-4 is located in the outer muscle cell membrane (insulin independent). In response to the binding of insulin to the insulin receptor in the interstitium, triggering a cascade of protein phosphorylation reactions that ultimately activate the translocation of Glut-4 stored in microsomal membranes are transported to the outer muscle cell membrane. (insulin dependent). [Lauritzen 2006] shows a time delay of 10 minutes between insulin leaving the interstitium and the first translocations of Glut-4 after intravenous insulin infusion. Maximum translocation of Glut-4 was reached after 30 minutes.

Three impairments exist in the above described mechanisms for type 2 diabetic humans: Impairment of Glut-4 translocation, impairment of the recruitment of muscle capillaries, and impairment of the inhibition of hepatic glucose production [Zijlstra 2004]. The contribution of each of these impairments is not clear, since only an overall insulin sensitivity ( $S_I$ ), the efficacy of insulin to glucose uptake by body tissues [ $1/(pM \cdot min)$ ], is used in experiments to quantify the whole insulin resistance.

The goal of this study is to develop a method to understand and quantify different potential causes of insulin resistance in type 2 diabetes under normal physiological conditions. For this purpose a novel model is to be developed and to be verified. In general the model will incorporate the main glucose regulating mechanism to obtain descriptions of the variables involved and to enable estimation of physiologically relevant parameters using measured data of glucose profiles, insulin profiles or others profiles of processes in a human.

The model should meet all the conditions for valid use in widespread clinical use. The oral glucose minimal model must describe the mechanism by which insulin regulates glucose uptake by muscle cells or adipose tissues as best as possible. Simplification of the model leads to undermodelling of the glucose regulatory system giving erroneous estimates. Overmodelling leads to complex model which are difficult to identify. The data from clinical measurements used for the novel model must be obtained during normal life conditions, the possibilities for invasive measurements in humans are limited and the costs of the measurements must be kept under a reasonable financial budget. Furthermore, the model must provide reliable unique estimates for the model parameters which describe the effects of Glut-4 translocation, the recruitment of muscle capillaries, and impairment of the inhibition of hepatic glucose production with high precision using the measurements techniques available, in other words the model needs to be identifiable for those parameters.

The first part of this report consists of modelling glucose kinetics in humans. First the mechanisms of glucose uptake by skeletal muscle and its possible impairments were discussed in this section. Further a closer analyse was made of the mechanism of transport of insulin from blood plasma through the endothelium to reach the interstitium list in appendix D. Secondly, several minimal models modelling the rate of appearance of glucose from the gut in the blood plasma are discussed. Thirdly, the new oral glucose minimal model is presented with its modifications compared to the classical minimal model of [Bergman 1979]. Finally the new oral glucose minimal model is represented in state space and the plasma

glucose, interstitial glucose, interstitial insulin and the rate of appearance of glucose are simulated using measured insulin profiles. A different approach could have been to use a model to simulate insulin (insulin profiles) that is secreted by pancreatic  $\beta$ -cells via the liver into the portal vein. A study discussing the model is list in appendix B.

The second part of this report consists of parameter estimation to identify the unknown parameters in the glucose metabolism model as optimal as possible. First, the glucose metabolism model is tested on a priori global identifiability and a posteriori identifiability. Secondly, the sensitivity of a priori parameters in relation with the estimated parameters is examined. Thirdly, the parameter estimation algorithm used is explained and also a technique is presented to calculate a lower bound of the precision that can be achieved for each parameter when estimating the parameters. Fourthly, an algorithm is designed to optimize the glucose input doses and an algorithm is designed to find the optimal sampling scheduling. Then the results are shown. Finally, a discussion is made and suggestions for future research are given.

## 2 Minimal Models

$S_I$  can be estimated in experiments with the Clamp technique, with the intravenous glucose tolerance test (IVGTT), with the meal oral glucose tolerance test (MGTT) or with the oral glucose tolerance test (OGTT). The Clamp technique consists of intravenous injecting a known insulin concentration together with an infusion of glucose to control the glucose concentration in blood plasma to a fixed value. The ratio of injected insulin and infused glucose provides a measure of insulin sensitivity. The IVGTT consists of injecting a known glucose concentration into the blood plasma. The glucose and insulin concentration in blood plasma are measured in time. The minimal model [R.N. Bergman 1979] is used to estimate parameters from which  $S_I$  is calculated. The CLAMP technique as well as the IVGTT use non-normal life conditions. The MGTT and OGTT are tests using normal life conditions. The MGTT uses an ingested meal containing glucose and the OGTT uses an ingested liquid containing glucose. The glucose and insulin profiles in blood plasma are measured. Also less surgical intervention is needed (only arterial and venous blood samples) than during a CLAMP or IVGTT. The minimal model of Bergman needs to be adapted to incorporate the rate of appearance of glucose from the gut in the blood plasma / systemic circulation of nutrient taken by mouth ( $Ra(t)$ ).

In the past two mathematical models without physiological meaning have successfully been used to estimate  $Ra(t)$ . The “integral equation” method is based on the assumption that  $Ra(t)$  is an anticipated version of blood plasma glucose concentrations [A. Caumo 2000]. The method calculates the areas under the measured glucose and insulin blood plasma concentrations. To properly calculate the areas, the glucose and insulin concentration have to return to basal levels. This may cause problems if the “integral equation” method is applied to humans with either impaired glucose tolerance or impaired insulin secretion, in which the return of glucose and insulin to the pretest levels requires a rather long time. Compared to the Bergman minimal model for an IVGTT, only two additional parameters need to be estimated. The “differential equation” method uses a piecewise-linear parametric model of  $Ra(t)$  [Dalla Man 5-2002]. An advantage of this method is that glucose and insulin concentrations do not have to return to basal value at the end of the test, hence, the experiment is dramatically shortened. Four additional parameters have to be estimated.

Two mathematical models with physiological meaning have been used successfully to estimate  $Ra(t)$ . [D.R.L. Worthington 1997] shows a physiological model which was tested on a type 1 diabetic humans. A one compartmental method was proposed, having the following physiological parameters: fraction content of glucose in the food normalized to glucose distribution volume, time constant of gastric emptying and the transport delay between ingestion of glucose and appearance of glucose in blood plasma. Advantages of this method are that only three additional parameters have to be estimated and the parameters are physiological.

An interesting physiological model is studied by [J.D. Elashoff 1982]. This model is used in this study. The model uses the exponential curve which follows a set of physiological and mathematical characteristics. The most important mathematical characteristic is that at time zero the fraction of glucose ingested ( $DS$ ) [g] is 1.0 and at infinite time the ingested fraction is 0.0. Further, the power exponential curve (1) also allows to have a slow initial emptying followed by an accelerated emptying ( $\beta > 1$ ). If  $\beta < 1$  the opposite occurs. This phenomenon is often seen in humans who have undergone an operation. If  $\beta = 1$  the exponential curve is obtained. Physiologically, the model uses the inverse of the time constant of gastric emptying ( $k$ ) [1/min] and  $\beta$ .

$$f(t) = e^{(-k \cdot t)^\beta} \quad (1)$$

Data of olders studies obtained by measuring the contents of different ingested meals (e.g. glucose contents) and taken samples of the contents of stomach and using by different healthy humans as well as by healthy humans with operated stomach were fit to (1) using nonlinear least squares regression. This model showed high goodness of fit with the measured data.

Another study [J. Schirra 1996] performed an experiment with eight healthy non-obese males using this power exponential curve (1). The experiment used 50 or 100 grams glucose dissolved in 400 ml water and drank in 2 minutes showing  $k$ 's and  $\beta$ 's with a very high precision.

Natalucci coupled the mono compartmental model [S. Natalucci 2003] using the power exponential curve (1) with the adapted minimal model [Bergman 1979] for an OGTT. Figure 1 shows this model were  $G_{gut}(t)$  [1/kg] is the mass of glucose in the gut and  $K_{abs}$  [1/min] is the rate constant of glucose absorption from the gut into blood plasma. The model was tested on nine non diabetic humans using a doses of 75 grams of glucose ( $DS$ ) dissolved in water. However, the parameters of the power exponential curve were not estimated, but the values  $\beta = 1.23$  and  $k = 0.014$  [1/min] were taken from [J. Schirra 1996]. The experiment showed  $S_1$  and  $K_{abs}$  with low variance.

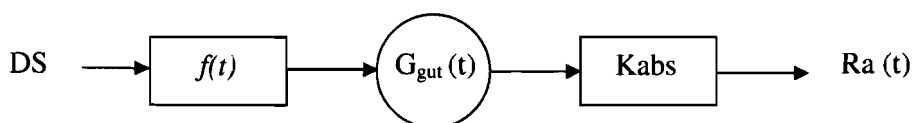

Figure 1: Mono compartmental model of the gut

### 3 New Oral Glucose Minimal Model

Since the contribution of the different potential impairments in the glucose regulatory system in type 2 diabetes, as stated in the introduction, is not clear yet, we propose to split up  $S_I$  in the individual components  $S_{I-cap}$ ,  $S_{I-glut-4}$  and  $S_{I-liver}$ .  $S_{I-cap}$  [ $1/(pM \cdot min)$ ] is the efficacy of insulin to stimulate insulin and glucose transport from blood plasma into interstitium by capillary recruitment.  $S_{I-glut-4}$  [ $1/(\mu M \cdot min)$ ] is the efficacy of insulin to stimulate glucose clearance in muscle and adipose tissue by GLUT-4 translocation.  $S_{I-liver}$  [ $1/(pM \cdot min)$ ] is the efficacy of insulin to inhibit hepatic production and stimulate glucose uptake by liver. The aim of this study was to modify the method developed by Bergman [R.N. Bergman 1979] to make this splitting possible.

[Zijlstra 2004] suggested a modification of the minimal model of Bergman. This modification consists of adding a (measured) interstitial glucose compartment to the classic minimal model, to model the control of glucose transport into the interstitium by insulin as discussed in the introduction. Adding this compartment could make the identification of the rate constant of transport of plasma glucose into the interstitial compartment possible. This extra compartment is not new, a remote (non-accessible, only exchange with the glucose blood plasma compartment) glucose compartment was already used during an IVGTT in [Cobelli 1999], during an OGTT [Dalla Man 10-2002] and references in there to avoid overestimation of  $S_C$  (the insulin independent glucose uptake) and underestimation of  $S_I$  seen in one Compartmental Minimal Models (1CMM) like the classic Bergman model. This extra compartment was also used in [Caumo 1993] and references in there to derive a time profile of endogenous hepatic glucose production during a labeled IVGTT. However, this extra compartment was not measured in all earlier models.

Another difference in the new oral glucose minimal model with the classic minimal model of Bergman is that inhibition of hepatic production and stimulation of glucose uptake by liver is regulated by plasma insulin instead of interstitial insulin as access to hepatocytes is immediate, due to a highly fenestrated endothelium [Bergman 2003]. Also, plasma insulin regulates the transport of insulin and glucose from plasma to interstitium as discussed in the introduction.

In the classic minimal model of Bergman  $S_C$  consists of the net rate of glucose produced by the liver and insulin independent glucose uptake by tissues like the brain. Unfortunately, those effects cannot be estimated independently. By using ingested labelled glucose, a distinction is made between ingested (labelled) glucose and the net rate of (non-labelled) glucose produced by the liver. By measuring the concentration of labelled glucose in blood plasma  $S_{I-liver}$  can be obtained as e.g. performed in [Dalla Man 10-2002].

The suggestions made by Zijlstra [Zijlstra 2004] together with the new suggestions made in this section, the previously discussed physiologic description of glucose appearance from the gut into blood plasma and with the saturable receptor-mediated insulin transport hypothesis (appendix D) resulted in the new oral glucose minimal model 1 shown in figure 2.



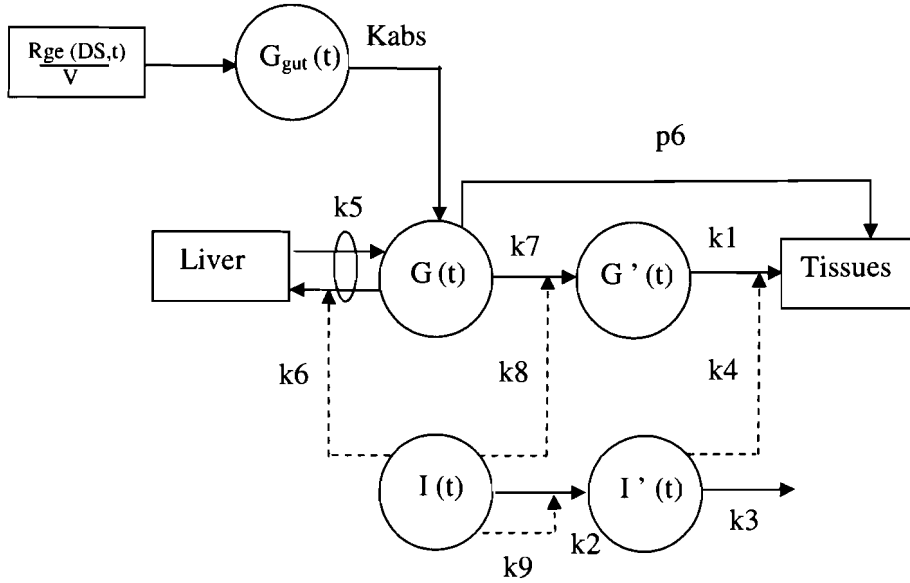

Figure 2: New oral glucose minimal model for glucose metabolism, derived from the classic minimal model of Bergman including a interstitial glucose compartment  $G'(t)$ , inhibition of hepatic production and stimulation of glucose uptake by liver regulated by plasma insulin  $I(t)$  instead of by interstitial insulin  $I'(t)$  and a physiologic description of glucose appearance from the gut into blood plasma  $G(t)$  and using a saturable receptor-mediated insulin transport from blood plasma to interstitium for insulin concentrations in physiological range

This new model consists of four compartments  $G(t)$  [mM], glucose plasma,  $G'(t)$  [mM], interstitial Glucose,  $I(t)$  [pM] insulin plasma and  $I'(t)$  [pM] interstitial insulin.  $R_{ge}$  [g/min] is the rate of gastric emptying,  $DS$  [g] is the amount of glucose ingested,  $G_{gut}(t)$  [I/g] is the mass of glucose in the gut and  $K_{abs}$  [1/min] is the rate constant of glucose absorption from the gut into blood plasma.

Glucose  $G(t)$  is transported at a rate proportional to  $k_7$  [1/min] to the interstitium and cleared to muscle and adipose tissue at a rate proportional to  $k_1$  [1/min]. Glucose plasma  $G(t)$  is also cleared to tissue in a non-insulin dependent way at a rate proportional to  $p_6$  [1/min].

Insulin  $I(t)$  is transported at a rate proportional to  $k_2$  [1/min] to the interstitium. Insulin  $I(t)$  controls the inhibition and stimulation of hepatic glucose uptake by liver ( $k_6$  [1/(pM·min)]). Also, insulin controls the transport of plasma glucose ( $k_8$  [1/pM]) and plasma insulin ( $k_9$  [1/pM]) to the remote compartments. Interstitial insulin controls glucose uptake by muscles ( $k_4$  [1/(pM·min)]) and is degraded at a rate proportional to  $k_3$  [1/min].

Figure 3 shows the reparameterized model of figure 2 (model 1). In model 1,  $p_2$  equals  $k_3$  [1/min],  $S_{I-cap}$  equals  $k_2 \cdot k_9$  [1/(pM·min)],  $p_4$  equals  $k_7 \cdot k_8$  [1/(pM·min)],  $p_5$  equals  $k_5$  [1/min],  $p_6$  equals  $S_C$  [1/min],  $S_{I-glut4}$  equals  $k_4 \cdot k_1$  [1/(pM·min)] and  $S_{I-liver}$  equals  $k_6$  [1/(pM·min)].

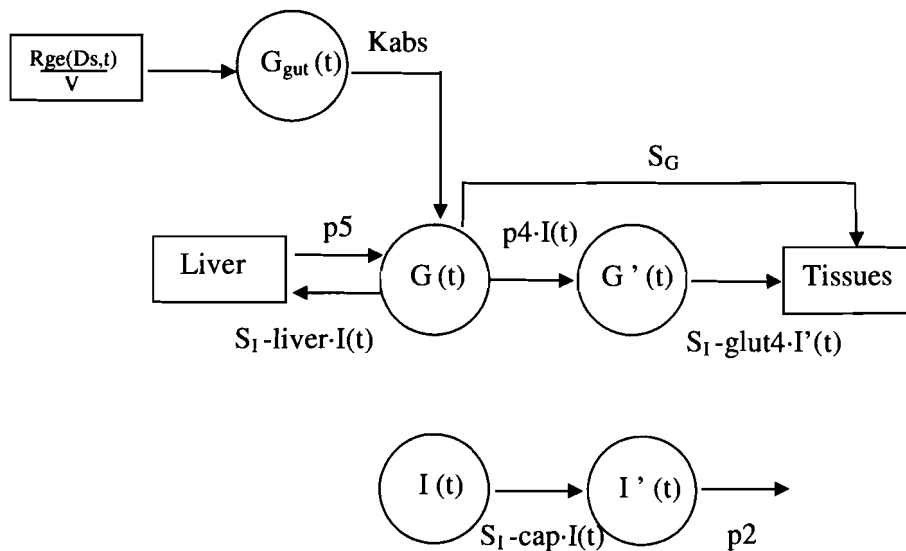

Figure 3: Reparameterized new oral glucose minimal model (model 1) for glucose metabolism

The reparameterized new oral glucose minimal model 1 of figure 2 can be modified further by including ingested labelled glucose  $GL(t)$  resulting in the new oral glucose minimal model 2 as shown in figure 4 (index  $L$  denotes the labelled glucose version of a compartment). Remark: Another method could be to enrich blood plasma with labelled glucose by injecting intravenous labelled glucose resulting in the new oral glucose minimal model 3. The new oral glucose minimal model 2 can easily be modified to describe this experimental setup.

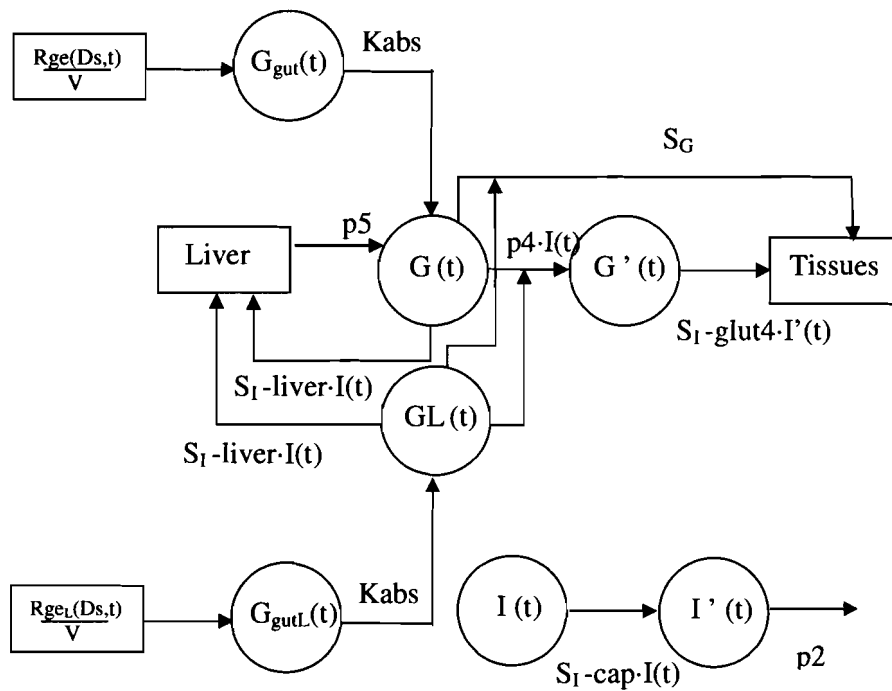

Figure 4: New reparameterized oral glucose minimal model (model 2) for glucose metabolism including labelled ingested glucose

The new oral glucose minimal model describes *jointly* the effects of Glut-4 translocation, the recruitment of muscle capillaries, and impairment of the inhibition of hepatic glucose production using existing minimal models in literature and modifying them using recent insights in the mechanism by which insulin regulates glucose uptake by muscle cells or adipose tissue. Knowing the *joint* interaction between these mechanisms is a great step forward to understand and quantify different potential causes of insulin resistance in type 2 diabetes. Furthermore, analyzing and verifying the new oral glucose minimal model *in all its aspects* (a priori and a posteriori identifiability, a priori parameter sensitivity) *and* performing optimal experiment design (optimal input and optimal sample schedule) is a great step forward in modelling glucose kinetics since to the authors knowledge it has never been applied all in one to a minimal model of glucose kinetics before.

## Methods

### 4.1 Measurements Techniques

The data will be obtained in the near future at the School of Sport and Exercise Sciences at the University of Birmingham. Sophisticated techniques are used to measure the concentrations of plasma glucose and insulin and interstitial glucose during an OGTT. Glucose and insulin in blood plasma are measured by taking samples by inserting an intravenous cannula (BD Venflon™) into one of the antecubital veins. The subject's arm is placed in a so-called 'hot box' in which the high temperature will arterialise the venous blood. The blood samples will be centrifuged at 3000g at 4°C for 10 min and stored at -70°C for later analysis of glucose and insulin.

Plasma glucose concentrations will be determined by the Cobas Mira Plus automated analyser (ABX Diagnostics, UK) with a coefficient of variation (CV) of 2% if measured in 10-fold. Plasma Insulin concentrations will be determined by a commercially available kit (DRG instruments GmbH, Germany) with a CV of 10%. Further, the interstitial glucose concentrations are measured by the microdialysis technique using custom made CMA107 microdialyse probe with a length of 3 cm, a MW cut off of 20000 and a coefficient of variation (CV) of 4%. Details of this technique are discussed in the next section.

#### 4.1.1 Microdialysis

The microdialysis technique [Lönnroth 1987, Lönnroth 1997] consists of the diffusion of a water-soluble substance over a dialysis membrane into a perfusion medium. It enables measurement of the interstitial fluid. The inlet of the catheter is perfused by a pump with a perfusion fluid (water containing isotonic saline) at a rate of 0.667 µl/min. Exchange occurs between the perfusion fluid and the interstitial fluid. After equilibrium is reached, subsequent dialyses samples (20 µl) are collected at the outlet of the catheter. The collected sample is a mean measurement over the time needed to reach equilibrium. The samples are analyzed for interstitial glucose. Due to the permeability of the dialysis membrane, maximal 85-90% of interstitial glucose is recovered in the dialysis. The microdialysis technique is not suitable for interstitial insulin measurements since very low recovery (+/- 3%) is achieved yet [Sjöstrand 2005, Sjöstrand 1999]. Another drawback of this method is that data samples

suffer from slow dynamics: interstitial mean glucose concentrations are only available after reaching equilibrium in about 30 minutes.

#### 4.2.1 Model Structure in State Space

The oral glucose minimal model 1 can be represented in state space. The state space model structure and its state space measurement model of a dynamic system is shown in equations (2, 3) and (4), respectively, where  $x$  is the  $n$ -state vector,  $u$  the multi input vector,  $f$  are linear or nonlinear functions which describe the structure of the system parameterized by vector  $\theta$ ,  $g$  are nonlinear or linear functions which describe the output configuration parameterized by vector  $\theta$ ,  $y_v[t_{iv}]$  are the measurements of the  $v$ th output sampled at  $N_v$  discrete times  $t_{iv}$ ,  $y_{vm}(t, \theta_i)$  is the modeled  $v$ th output at time  $t$  or sampled at  $N_v$  discrete times  $t_{iv}$ ,  $e_v$  is the measurement error, assumed to be additive zero mean white noise with known variance  $\sigma_v^2(t_i)$  and  $M$  the number of measured outputs.

State equation:

$$\dot{x}(t, \theta_i) = f(x(t, \theta_i); u(t), \theta_i) \quad x(t_0, \theta_i) = x_0 \quad (2)$$

Output equation:

$$y_v(t, \theta_i) = g_v(x(t, \theta_i); \theta_i) \quad (3)$$

Measurement model:

$$y_v[t_{iv}] = y_{vm}[t_{iv}, \theta_i] + e_v[t_{iv}] \quad i=1, 2, 3, \dots, N_v, \quad v=1, 2, 3, \dots, M \quad (4)$$

This framework includes non-equidistant time samples, that not all outputs (blood plasma glucose and interstitial glucose) are sampled at the same time points and outputs measured with different accuracy. It should be noted that for the glucose minimal model two different types of input variables have to be discriminated. The orally ingested glucose can be manipulated by the experimenter and, therefore, is an independent input, which, in system theory, is commonly denoted by  $u(t)$ . In our approach the measured insulin profile is also applied as an input to the minimal model. However, since this input is a variable which results from the response of the system to the independent input  $u(t)$ , it is not independent.

The concept of 'dependent inputs' allows the opening of some of the feedback loops that connect the system of interest to the rest of the closed loop real system [van Riel 2006]. The model can focus on a smaller part of the system, as long as this subsystem is still integrated in its real system through the measured input signal. If the system contains a subsystem (state variables) which output can be measured, this subsystem (state variables) can be substituted by using the measured signal as input to the system (dependent input  $v(t)$ ) as shown in (5). The number of states of the system is reduced. The drawback is a loss of predictive power, because the 'open-loop' model can only be used to simulate situations for which the dependent inputs have been measured in the real system. To solve the differential equations for the used integration step, the measured dependent input signal  $v(t)$  is linearly interpolated. If the dependent input(s)  $v(t)$  can be (accurately) measured in time, these signal can be used as forcing functions for these input(s).

$$\dot{x}(t, \theta_i) = f(x(t, \theta_i); u(t), v(t), \theta_i) \quad x(t_0, \theta_i) = x_0 \quad (5)$$

### 4.2.2 Simulation

The differential equations have been solved in Matlab by the differential equation solver Ode45. The relative error tolerances (RelTol) of the solutions were set four orders lower than the amplitudes of the outputs to  $1 \cdot 10^{-4}$  and the absolute error tolerances (AbsTol) were set two orders smaller than RelTol to  $1 \cdot 10^{-6}$ .

### 4.3 Identifiability

The parameters of the new oral glucose minimal model 1, 2 and 3 are tested on a priori global identifiability and a posteriori identifiability to analyse which parameters can be estimated using the measured techniques discussed in section 4.1. A parameter can be estimated if its variance has an acceptable low value.

A priori global identifiability consists of analyzing the structure of the model to verify which parameters can be estimated using the measured techniques discussed in section 4.1 and using noise-free data without having any a priori information about the parameters. In contrast to a priori global identifiability, a posteriori identifiability verifies which parameters can be estimated by analysing the effects of the dimensions of the parameters, the effects of different input profiles and the effects of different sample schedules.

#### 4.3.1 A Priori Global Identifiability

A priori global identifiability under noise-free conditions has been examined by using an algorithm based on differential algebra [Audoly 2001]. Briefly, the algorithm consists of first deriving one equation which is algebraic observable, in other words may only contain the model input and output variables and their derivatives and not contain any states or its derivatives. The input-output differential equation representation of a dynamic model has this property. Hence, the differential equation has to be derived from the state space representation of the model. In [Audoly 2001] this is done by eliminating all states in each equation of the state space representation by substituting state equations or their derivatives in each other, the so called characteristic set of the model, resulting in one equation without states, the so-called input-output relation of the model

The differential equation of the model is identical to the input-output relation of the model. The differential equation is used to find the set of identifiable parameters by extracting the coefficients of the differential equation of the model. These coefficients are subtracted by the same coefficients which are substituted by a random numerical point in the parameter space for the unknown parameters. An example is shown below:

Example A:

Differential equation:

$$c1 \cdot c2 \cdot x(t) + c3/c2 \cdot \dot{x}(t) = 0 \quad (a1)$$

Coefficients of the differential equation:

$$c1 \cdot c2, c3/c2 \quad (a2)$$

A random numerical point in the parameter space for the unknown parameters:

$$\begin{aligned} c_1 &= 12 \\ c_2 &= 4 \\ c_3 &= 36 \end{aligned} \tag{a3}$$

Coefficients of the differential equation subtracted by the same coefficients substituted by random numerical point in the parameter space for the unknown parameter:

$$c_1 \cdot c_2 - 48 = 0 \tag{a4}$$

$$c_3 / c_2 - 9 = 0 \tag{a5}$$

The obtained set of coefficients (example 1: (a4, a5)) of the differential equation, which are called exhaustive summary in [Audoly 2001], are solved by the Buchberger algorithm [Buchberger 2001] obtaining the Gröbner basis as shown in (a6). If this basis has a finite number of solutions, all parameter can be estimated properly. Else, non-identifiable parameters have to be estimated jointly, to obtain a finite number of solutions of the Gröbner basis. In example 1  $C_1$  and  $C_2/C_3$  are identifiable.

$$\begin{aligned} 9c_2 - c_3 \\ -9 + c_3 / c_2 \\ c_1 - 48 / c_2 \end{aligned} \tag{a6}$$

The algorithm described in [Audoly 2001] assumes generic initials conditions for the state space model. Generic initials conditions are initial equations which are not restricted to a particular value. If non-generic initials conditions are used, parameters could not be observable in the differential equation leading to parameters which cannot be tested on identifiability using this algoirtum. Hence, if non-generic initials conditions are used a manual check needs to be done to verify if unknown parameters are not observable when deriving the input-output relation of the model. If parameters vanish, the set of state equations of the state space representation needs to be enlarged by adding the polynomials evaluated at these initial conditions. In other words, the initial condition is filled in the state space representation of the model and this polynomial is added as extra equation in the state space representation of the model. The input-output relation must be recalculated.

[Saccomani 2002, Saccomani 2001] presented a modified algorithm based on [Audoly 2001] for dealing with those non-generic initial conditions. The algorithm is based on the lack of reachability / accessibility from the initial state. If the system is accessible from all initial states, the characteristic set of the model is valid. Else the characteristic set needs to be enlarged adding the polynomials evaluated at the initial conditions which lacks of accessibility. The accessibility property of a model is checked by using the accessibility Lie Algebra (6) where  $\partial / \partial x$  denotes the Jacobian matrix,  $A$  are the polynomials of the state space model which are multiplied by the states  $x$  and  $B$  are the polynomials of the state space model which are multiplied by the input  $u$  as defined in (7). A model is accessible from its initial conditions if the so-called accessibility rank condition holds for each initial condition [Sontag 1998]. The accessibility rank condition is satisfied when the linear span of all vectors functions that can be obtained starting with the  $A$ 's and taking any numbers of Lie brackets of them as shown in (8) has the same dimension as the state space model.

$$[A, B] = \left( \frac{\partial}{\partial x} B \right) A - \left( \frac{\partial}{\partial x} A \right) B \quad (6)$$

$$\dot{x} = A \cdot x + B \cdot u \quad (7)$$

$$[A, B], [A, [A, B]], [A, [A, [A, B]]], [A, [A, [A, [A, B]]]], \dots = [AB], [A^2B], [A^3B], [A^4B], \dots \quad (8)$$

#### 4.3.2 A posteriori Identifiability

The model to model adjustment [Damen 2005] approach has been used to analyse the a posteriori identifiability using different input profiles under noise and noise-free conditions and under. The effect using when using different samples schedules can also be studied. Model to model adjustment consists of analyzing the error cost function (9) for combinations of parameters  $\tilde{\theta}$  with different values in the parameter space where  $y_v(t_{iv})$  are the measurements of the  $v$ th output sampled at  $N_v$  discrete times  $t_{iv}$ ,  $y_{vm}(t_{iv}, \theta_i)$  are the modeled  $v$ th output sampled at  $N_v$  discrete times  $t_{iv}$  using the parameters  $\theta_i$ ,  $z_v$  is the  $v$ th output weighting factor,  $\theta_i$  are the true parameters,  $N_v$  the number of samples taken for each output  $v$  and  $M$  the number of outputs.

$$J(\tilde{\theta}) = \frac{1}{N_v} \sum_{i=1}^N \sum_{v=1}^M z_v \left( y_v(t_{iv}, \theta_i) - y_{vm}(t_{iv}, \tilde{\theta}) \right)^2 \quad (9)$$

The 2 dimensional contour plot, plots the cost function (the model error) for two parameters for a range of values. Other parameters in the parameter space are kept fixed at the true parameter  $\theta_i$ . If the combination of parameter is identifiable, the contour plot shows concentric ellipses centered at the supposed true values of the two parameters (global minima). The more narrow and steeper the concentric ellipsis are, how more accurate the estimation of both parameters will be.

#### 4.3.3 A Priori Parameters Sensitivity

Parameters which are not identifiable by the used model setup in combination with the used experimental setup have been set a priori. Unfortunately, parameters can vary among population. The parameter sensitivity shows if a non-identifiable parameter can be set a priori without losing significant precision of the parameters when the non-identifiable parameter varies significantly among population. Therefore the parameters sensitivities have been calculated by varying the a priori parameters one by one over a fixed range with respect to the true known parameter, setting the value of the other a priori parameters fixed, estimating the corresponding unknown identifiable parameters and finally calculating the corresponding parameter covariance matrix  $\Delta(\theta)$  which will be explained in section 4.4. If the identifiable parameters are unbiased, the determinants of the obtained covariance matrices are an indication for the parameter sensitivity for variation of the a priori parameter. Else, if estimates were not unbiased, the worstcase bias technique, as stated in the last paragraph of section 4.4, has been used.

#### 4.4 Parameter Estimation

Several algorithms exist to estimate parameters of a model, such as: Weight Least Squares estimation (WLS), Maximum Likelihood estimation (ML), Generalized Least Squares estimation and Bayesian estimation (MAP). In this study Maximum Likelihood estimation has been used since the noise introduced by the measurements techniques used (section 4.1) can be assumed to be white, Gaussian, zero mean and with variance  $\sigma_v^2$ .

The ML criterion assumes that the measured  $\nu$ th output  $y_\nu$  sampled at  $N_\nu$  discrete times  $t_{i\nu}$  consists of the modelled  $\nu$ th output  $y_{\nu m}$  depending on true parameters  $\theta_i$  and noise  $e$  as shown in (10). which is different from (4) since the parameter vector has been split in a priori unidentifiable parameters which were kept fixed  $\theta_{fix}$  and the identifiable parameters which have been estimated  $\theta_{est}$ .

$$y_\nu[t_{i\nu}] = y_{\nu m}[t_{i\nu}, \theta_{fix}, \theta_{est}] + e_\nu[t_{i\nu}] \quad i=1, 2, 3, \dots, N_\nu, \quad \nu=1, 2, 3, \dots, M \quad (10)$$

The probability density function of Gaussian noise is shown in (11).

$$p_\nu(e_\nu(t)) = \frac{1}{\sqrt{2\pi}\sigma_\nu} e^{-\frac{e_\nu(t)^2}{2\sigma_\nu^2}} \quad (11)$$

Combining equations (10) and (11) and assuming that the consecutive noise samples are independent, results in the likelihood function for the residue of the  $\nu$ th output with variance  $\sigma_\nu^2$  (12).

$$L(y_\nu | \theta_{est}) = \left( \frac{1}{\sqrt{2\pi}\sigma_\nu} \right)^{N_\nu} e^{-\sum_{i=1}^{N_\nu} \frac{(y_\nu(t_{i\nu}) - y_{\nu m}(t_{i\nu}, \theta_{fix}, \theta_{est}))^2}{2\sigma_\nu^2}} \quad (12)$$

The noise is assumed to be white, Gaussian, zero mean and with variance  $\sigma_\nu^2$ . This assumption has been checked, as will be discussed in this section, after having estimated the parameters.

The likelihood function for the residues of all outputs  $M$  is shown in (13).

$$L(y | \theta_{est}) = \prod_{\nu=1}^M \left( \frac{1}{\sqrt{2\pi}\sigma_\nu} \right)^{N_\nu} e^{-\sum_{i=1}^{N_\nu} \sum_{\nu=1}^M \frac{(y_\nu(t_{i\nu}) - y_{\nu m}(t_{i\nu}, \theta_{fix}, \theta_{est}))^2}{2\sigma_\nu^2}} \quad (13)$$

Taking the log of (13) results in the cost function for the ML (14) [Damen 2005 p. 47-62].

$$J(\theta_{est}) = \sum_{i=1}^{N_\nu} \sum_{\nu=1}^M \frac{(y_\nu(t_{i\nu}) - y_{\nu m}(t_{i\nu}, \theta_{fix}, \theta_{est}))^2}{2\sigma_\nu^2} \quad (14)$$



The model parameters  $\theta_{est}$  are estimated by minimizing (14) as shown in (18).

$$\theta_{est} = \arg \min_{\theta_{est}} J(\theta_{est}) \quad (15)$$

Function minimization of (15) has been accomplished in Matlab using the non linear least square estimation algorithm lsqnonlin which uses the Medium-Scale Gauss-Newton Algorithm with Line search cubicpoly. The minimization of (15) stopped when the variation in cost function, between two subsequent iterations was less than TolFun or the absolute parameters value changed less than TolX. TolFun was set much lower than the amplitudes of the weighted outputs  $z_v y_v$  to  $1 \cdot 10^{-4}$  and TolX, a factor 1000 lower than the lowest true value of the estimated parameter set to  $1 \cdot 10^{-10}$ . The minimization algorithm also stops after a number of iterations is reached. The maximal number of iterations was set to 800.

After having estimated the parameters, the residues of the criterium  $J_v(\theta_{est})$  must be analyzed to ensure that the assumption made earlier that the noise is Gaussian, zero mean with variance  $\sigma_v^2$  is true. For white noise it holds that consecutive noise samples are independent. Its mean is zero and its autocorrelation function  $\phi_v(t_{shift})$  (16) takes the form of a pulse at zero time shift and is zero elsewhere (Dirac pulse).

$$\phi_v(t_{shift}) = \frac{1}{N_v} \sum_{i=1}^{N_v} J_v(t_{iv}, \theta_{est}) \cdot J_v(t_{iv} + t_{shift}, \theta_{est}) \quad (16)$$

The lower bound of the parameter covariance matrix  $\Delta(\theta_{est})$  of the estimated model parameters  $\theta_{est}$  is obtained (using the Cramer-Rao theorem) from the inverse of the Fisher information matrix  $F(\theta_{est})$  [Walter 1997 p. 245-250] as shown in (17). If MLE qualifies as an unbiased and minimum variance estimator, the lower bound in (17) becomes an equality.

An estimator is unbiased if (18) holds where E denotes the expectation. In addition, if the variance  $\sigma_v^2$  is set to the inverse of de data covariance of the disturbance and  $N_v \gg n_\theta$  (number of parameters) holds, MLE qualifies as an asymptotically unbiased and minimum variance estimator [Damen 2005], respectively.

$$\begin{aligned} \lim_{N \rightarrow \infty} \Delta(\theta_{est}) &= F^{-1}(\theta_{est}) = \sum_{v=1}^M \left( \begin{matrix} E \\ y_{vm} | \theta_{est} \end{matrix} \left\{ \frac{\partial^2 \left( -\ln(L(y_{vm} | \theta_{fix}, \theta_{est}))) \right)}{\partial \theta_{est} \partial \theta_{est}^T} \right\} \right)^{-1} \\ &\approx \sum_{v=1}^M \left( \frac{1}{N_v} \sum_{i=1}^{N_v} \frac{1}{2\sigma_v^2} \frac{\partial y_{vm}(t_{iv}, \theta_{fix}, \theta_{est})^2}{\partial \theta_{est}} \frac{\partial y_{vm}(t_{iv}, \theta_{fix}, \theta_{est})^2}{\partial \theta_{est}^T} \right)^{-1} \end{aligned} \quad (17)$$

$$E(\theta_{est} - \theta_t) = 0 \text{ for } N_v \gg n_\theta \quad (18)$$

with  $E$  the expected value and  $n_\theta$  the number of estimated parameters. The variance  $\sigma_v^2$  in (17) has been determined a posteriori. After having estimated the parameters, information is available concerning the variance  $\sigma_v^2$ . It is set to the squared 2-norm of the residues of  $J(\theta_{est})$  (14).

If the parameters are biased ( $E(\theta_{est} - \theta_t) \neq 0$ ) the parameter covariance matrix cannot be calculated using (17). In this case, the relative worst case bias is used to provide a measure of the (in)accuracy of the parameter estimations. The relative worst case bias as shown in (19) has been calculated for each identifiable parameter  $\theta_{est}$  in the parameter space by varying the initial values of each identifiable parameter one  $\theta_{est}$  by one between -50 to +50% of  $\theta_t$  in steps of 10%, setting all other identifiable parameter fixed and estimating its value using the maximum likelihood estimation technique and adding for each estimation procedure  $q$  a different sequence of noise to the synthetic data with a 1/SNR of 0%, 5% or 10%. The relative worst case bias is then the maximal difference found, among all  $Q$  estimation procedures, between estimate  $\theta_{est,q}$  and true value  $\theta_{t,i}$  as shown in (20).

$$Bias_{rel}(\%)_{est,q} = \frac{|\theta_{est,q} - \theta_t|}{\theta_t} \cdot 100\% \quad q = 1, 2, 3 \dots, Q \quad (19)$$

$$Bias_{rel}(\%)_{est} = \text{Max}_\theta(Bias_{rel}(\%)_{est,q}) \quad (20)$$

## 4.5 Optimal Experiment Design

Designing an optimal experiment for parameter identification consists primary of selecting the inputs and outputs to make all parameters of interest in the model identifiable (section 4.3). Secondary, it consist of choosing a suitable parameter estimation algorithm, optimizing the shape of the input signal, choosing the optimal sampling schedule, choosing the type of sensors etc. to get the maximal information from the obtained data.

Since the choices of inputs and outputs were restricted due to physical accessibility, optimal experiment design has been focused on optimizing the glucose input doses and choosing the optimal sampling schedule discussed in section 4.5.1 and 4.5.2 respectively.

### 4.5.1 Optimal Input Shaping

An optimal input can be determined by the D-optimality criterion [Walter 1997 p. 287-291] as applied in [Cobelli 1988] if the identifiable parameters are unbiased. D-optimality criterion consists of minimizing the determinant of the parameter covariance matrix, which is equivalent to maximizing the determinant of the Fisher information matrix (17) (unbiased and minimum variance estimator) for the input signal  $u(t)$  using a conventional sample schedule that is *intuitively* used by experts. The optimal input criterion for each  $v$ th output is shown in (21).

$$\begin{aligned}
& \underset{u(t)}{MIN}\{\det[\Delta(\theta_{est}, u(t))]\} \\
& = \underset{u(t)}{MAX}\{\det[F(\theta_{est}, u(t))]\} = \underset{u(t)}{MAX}\left\{\det\left(-\sum_{v=1}^M E_{y_{vm}|u} \left\{ \frac{\partial^2 \ln(L(y_{vm} | \theta_{fix}, \theta_{est}, u(t)))}{\partial \theta_{est} \partial \theta_{est}^T} \right\}\right)\right\} \quad (21) \\
& \approx \underset{u(t)}{MAX}\left\{\det\left(\left(\frac{1}{N_v} \sum_{i=1}^{N_v} \frac{1}{2\sigma_v^2} \frac{\partial (y_{vm}(t_{iv}, \theta_{fix}, \theta_{est}, u(t)))^2}{\partial \theta_{est}} \frac{\partial (y_{vm}(t_{iv}, \theta_{fix}, \theta_{est}, u(t)))^2}{\partial \theta_{est}^T}\right)\right)\right\}
\end{aligned}$$

If the identifiable parameters are biased, (17) cannot be used to estimate the variance of the parameters. In this case, the relative worst case bias technique has been used as measure of parameter accuracy, as discussed in the last paragraph of section 4.4.

#### 4.5.2 Optimal Sample Schedule

The parameter covariance matrix  $\Delta(\theta_{est})$  also depends on the used sample schedule according to the inverse of the Fisher information matrix (17).

The optimal sample schedule for each output is determined by maximizing the determinant of the Fisher matrix (17) (D-optimality) (unbiased and minimum variance estimator) for each sample taken ( $t_{iv}$ ) if the identifiable parameters are unbiased. The optimal sample schedule criterion for each  $v$ th output is shown in (22).

$$\begin{aligned}
& \underset{t_{iv}}{MIN}\{\det[\Delta(\theta_{est}, t_{iv})]\} \\
& = \underset{t_{iv}}{MAX}\{\det[F(\theta_{est}, t_{iv})]\} = \underset{t_{iv}}{MAX}\left\{\det\left(-\sum_{v=1}^M E_{y_{vm}|P, t_{iv}} \left\{ \frac{\partial^2 \ln(L(y_{vm} | \theta_{fix}, \theta_{est}, t_{iv})))}{\partial \theta_{est} \partial \theta_{est}^T} \right\}\right)\right\} \quad (22) \\
& \approx \underset{t_{iv}}{MAX}\left\{\det\left(\sum_{v=1}^M \left(\frac{1}{N_v} \sum_{i=1}^{N_v} \frac{1}{2\sigma_v^2} \frac{\partial (y_m(\theta_{fix}, t_{iv}, \theta_{est}, t_{iv}))^2}{\partial \theta_{est}} \frac{\partial (y_m(\theta_{fix}, t_{iv}, \theta_{est}, t_{iv}))^2}{\theta_{est}^T}\right)\right)\right\}
\end{aligned}$$

If the parameters are biased the Fisher information matrix cannot be used. In this case the relative worst case bias, as stated in the last paragraph of section 4.4, has been used to provide the variance of the parameter estimations.

Several algorithms are based on starting with a conventional sample schedule (the sample schedule which is used normally) where each individual sample is optimized by comparing it with its neighbouring samples in the conventional sample schedule. If by taking a neighbouring sample, the determinant of the Fisher matrix is increased, this new sample is exchanged with the old one [Mori 1979], [Landaw 1982], [Xianjin 2000].

The algorithm developed in this study starts at the first sample of the conventional sample schedule searching for the first sample within a fixed horizon of samples that increases the precision. This sample is exchanged with the old one. This process is repeated until the maximal duration of the experiment is achieved. If after finishing, the optimal sample schedule contains too many samples than ethical/financial possible, the fixed horizon of samples is increased. Changing the horizon of samples is stopped when the optimal sample schedule contains the desired number of samples.

The search horizon was taken arbitrary to reduce the number of samples taken: twice the time needed to measure interstitial glucose. The optimal samples have been selected in the range (domain) of the conventional samples

The outputs do not have to be sampled at the same time points. The samples are separated by at least the time needed to take a measurement of the output. Measurement of  $G(t)$  takes much less than one minute and measurement of  $G'(t)$  takes thirty minutes.

## Results

### 5.1.1 Model Structure in State Space

The new oral glucose minimal model 1, valid for insulin concentrations in a physiological range (up to 600 pM), is a multi input multi output (MIMO) nonlinear dynamic system consisting of a four state-vector (26-29) having one independent input, one dependent input and two outputs. The independent input is  $DS$  [g], the dependent input  $I(t)$  [pM] and the outputs (30-31) are  $G(t, \theta_i)$  [mM] and  $\overline{G'(t, \theta_i)}$  [mM] a mean over each 30 minutes as stated in section 4.1.2. The dependent input could become an independent input if simulated using the  $\beta$ -cell insulin secretion models which are list in Appendix B. The outputs are sampled at discrete time  $t_i$  with  $N_G$ ,  $N_{G'}$  samples, respectively, as shown in (32, 33) were  $G_m[t_i, \theta_{fix}, \theta_{est}]$  is the modelled quantized glucose output and  $\overline{G'_m[t_j, \theta_{fix}, \theta_{est}]}$  is the modelled quantized mean interstitial glucose output over each 30 minutes. Due to measurement restrictions, the minimum time intervals of samples of  $G(t, \theta_i)$  and  $\overline{G'(t, \theta_i)}$  were taken as 1 minute and 30 minutes, respectively.  $e_v$  is the measurement error, assumed to be additive zero mean white noise with known variance  $\sigma_v^2$  for output  $v$ . The remaining parameters are  $G_b$  [mM] which is the basal glucose concentration,  $I_b$  [pM] the basal insulin concentration,  $\sigma_1^2$  the variance of the measurement noise and  $\sigma_2^2$  the variance of the measurement noise.

$$\dot{G}(t) = -[S_{liver} + p4] \cdot [G(t) - G_b] \cdot [I(t) - I_b] + p5 + S_G \cdot G(t) \cdot \frac{Kabs \cdot G_{gut}(t)}{V} \quad (26)$$

$$G(0) = G_b$$

$$\dot{I}'(t) = -p2 \cdot I'(t) + S_{I-cap} \cdot [I(t) - I_b]^2 \quad I'(0) = 0 \quad (27)$$

$$\dot{G}'(t) = -S_{I-gluc-4} \cdot I'(t) \cdot G'(t) + p4 \cdot [G(t) - G_b] \cdot [I(t) - I_b] \quad G'(0) = G'_b \quad (28)$$

$$\dot{G}_{gut}(t) = DS \cdot k \cdot \beta \cdot e^{(-k \cdot t)^\beta} - Kabs \cdot G_{gut}(t) \quad G_{gut}(0) = 0 \quad (29)$$

$$y_1(t, P_i) = G(t, \theta_i) \quad (30)$$

$$y_2(t, P_i) = \overline{G'(t, \theta_i)} \quad (31)$$

$$y_1[t_i] = G_m[t_i, \theta_{fix}, \theta_{est}] + e_v[t_i] \quad i=1, 2, 3, \dots, N_G. \quad (32)$$

$$y_2[t_j] = \overline{G'_m[t_j, \theta_{fix}, \theta_{est}]} + e_v[t_j] \quad j=1, 2, 3, \dots, N_G. \quad (33)$$

### 5.1.2 Simulation

Synthetic datasets are produced by simulating the model states space representation in Matlab using parameters found in literature for healthy non-obese humans and measured insulin input profile from [Wagenmakers 2006]. Sixth datasets were produced. Details of the datasets and plots used are shown in appendix C. Plots of the simulated glucose and insulin plasma and interstitial glucose data are also found in appendix C.

The parameters  $k$ ,  $Kabs$ ,  $\beta$ , and  $DS$  related by the gut were estimated in [Natalucci 2003] and [Schirra 1996] as stated in section 3, the parameters  $p5$  and  $S_I-liver$  related by the liver were estimated by the two compartment minimal model (using a non-accessible interstitial glucose compartment, but having similar behaviour as a accessible interstitial glucose compartment) [Dalla Man 10-2002] and [Caumo 1993], the parameters  $p2$ ,  $p6$  and  $V$  were estimated by the (improved) hot IVGTT two compartment minimal model [Toffolo 2003], the parameter  $k7$  was estimated by [Regittnig 2003] using *high* frequently sampled ISF (open-flow microperfusion) which uses a mathematical model [Steil 1996] to describe transendothelial transport of glucose from blood plasma to remote interstitium and finally  $k2$  was estimated by experimental data of [Sjöstrand 2005] using *low* frequently sampled ISF (microdialysis) and a mathematical model [Steil 1996] to describe transendothelial transport of insulin from blood plasma to remote interstitium. Mean values and variances are shown in table 1. No a priori information of the parameters  $k8$ ,  $k9$  and  $S_I-glut4$  were found in literature. Parameters  $k8$  and  $k9$  have been, to the authors knowledge, never been estimated. Since the product of  $k7/k2$ ,  $k8/k9$  and  $I(t)$  must be in the range of the transport from blood plasma to interstitium  $k7/k8$ , these parameters were first settled roughly, proportional to the inverse of the concentration of insulin to maintain the same range of transport. Secondly, parameters  $k8$  and  $k9$  were adjusted by trial and error producing a possible dataset of glucose kinetics.  $S_I-glut4$  was totally unknown and was set by the trial and error method just discussed.

$Kabs$	$Beta$	$k$	$v$	$k9$	$p2$	$S_I-cap$
$2.89 \cdot 10^{-2}$ $\pm 0.92 \cdot 10^{-2}$	1.23 $\pm 0.09$	0.014 $\pm 0.001$	1.386 $\pm 3.7 \cdot 10^{-2}$ <sup>II</sup>	$\pm 2.0 \cdot 10^3 \cdot$ $(1/0.21)^3$ <sup>III</sup>	0.113 $\pm 0.023$	$k2 \cdot k9$
$S_G$	$k2$	$k8$	$S_I-glut4$	$k7$	$S_I-liver$	$p4$
0.018 $\pm 0.006$	0.0395 $\pm 0.008$	$\pm 3.0 \cdot 10^{-2}$ <sup>I</sup>	$\pm 1.0 \cdot 10^{-2}$	$(0.063 \pm 7 \cdot 10^{-3})$ $\cdot (1/0.21)$ <sup>III</sup>	$1.57 \cdot 10^{-6}$ $\pm 1.08 \cdot 10^{-6}$ <sup>I</sup>	$k7 \cdot k8$

Table 1: Overview of the parameter value used in the new oral glucose minimal model 1 to simulate the sixth datasets (appendix C)

<sup>I</sup> Conversion factor between [ml/min 1/ $\mu$ U] to [1/min 1/pM]: 1/7.0625, <sup>II</sup> Conversion factor between [dl/mg] to [1/min 1/mM]: 180.16 1/mM, <sup>III</sup> Ratio between distribution volume of blood plasma and interstitial fluid.

## 5.2 Identifiability

In the new oral glucose minimal model 1 two outputs are measured namely, measurement of plasma glucose  $G(t)$  and interstitial glucose  $G'(t)$ . A restriction exists for measurements of interstitial glucose  $G'(t)$ , as only a mean measurement is available over each 30 minutes ( $\overline{G'(t)}$ ) as stated in section 4.1.2. This restriction is taken into consideration by calculating the mean of  $\overline{G_m'(t)}$  over 30 minutes using the parameters  $\theta_i$  in the oral minimal glucose model. The mean is calculated by summing up the values of  $G_m'(t)$  with intervals set to one-fifth of the smallest experimental time constant used in the model and dividing it by the number of intervals.

### 5.2.1 A Priori Global Identifiability

A priori global identifiability is done for the new oral glucose minimal models 1, 2 and 3. First the manual check is performed to verify if unknown parameters are not observable when dealing with non-generic initial conditions. Fortunately all parameters are observable. Table 2 shows the identifiable parameters.

	Identifiable parameter sets
<b>model 1</b>	Ib, Gb, kabs, v, p4, and Sicap or Siglut4
<b>model 2</b>	Ib, Gb, kabs, v, p4, SiLiver or p5 and Sicap or Siglut4
<b>model 3</b>	Ib, Gb, kabs, v, p4, SiLiver or p5, Beta or k and Sicap or Siglut4

Table 2: Overview of the a priori global identifiability parameters for models 1, 2 and 3

A remark can be made about the identifiability of  $S_I\text{-cap}$ .  $S_I\text{-cap}$  can be identified separately if the interstitial insulin  $G'(t)$  profile is measured and  $p_2$  is known a priori. Unfortunately, measurements of interstitial insulin  $G'(t)$  are not available. However, the interstitial insulin profile can be estimated after estimating  $S_I\text{-glut4}$ . In this case the variance of  $S_I\text{-cap}$  depends on a summation of two parts. One part is its own variance when estimating it from the measured plasma insulin profile and estimated interstitial insulin. The other part is non linear and depends on the variance of  $S_I\text{-glut4}$ .

### 5.2.2 A Posteriori Identifiability

The cost function of the new oral glucose minimal model 1 is evaluated for the plasma glucose output signal and the interstitial glucose output signal. The cost function is shown in (34).

$$J(\theta) = \frac{1}{N_G} \cdot \sum_{i=1}^{N_G} (G(t_i) - G_m(t_i, \theta))^2 + \frac{1}{N_{G'}} \cdot \sum_{i=1}^{N_{G'}} (\overline{G'(t_i)} - \overline{G_m'(t_i, \theta)})^2 \quad (34)$$

For each combination of the two dimensions in the parameter space, the contour plot of the error function is plot for model 1 (DS=75 gram), 2 (DS=72 gram, labelled ingested glucose 3

gram) and 3 (DS=75 gram, enrichment labelled glucose 3%) with variations of the parameter  $\theta_i$  of +/- 50 % using steps of 5%. The contour lines for  $J(\theta) \leq 10$  are plot at 0.01 distance from each other. For  $J(\theta) > 10 \leq 200$ , the contour lines are plot at 5.00 distance from each other. The contour plots also include estimation results indicated by red circles. (The true value is indicated with a red plus-sign.) The a posteriori identifiability is examined for the first and the second data set described in section 5.1.2 / appendix C with added white noise having a  $1/\text{SNR}$  of 0 % and 5%. Plots, not all, are shown in Appendix D.

Appendix D shows for model 1 using dataset 1, that the contourplots for all possible combinations of parameters  $kabs$ ,  $p_4$ ,  $S_1\text{-glut}_4$  and  $Gb$  are narrow and steep centered at the supposed true values of the two parameters (global minima). In contrast, parameter  $Ib$  shows for the same combinations of parameters in almost all case heavily stretched ellipses indicating poor-identifiable parameters. Parameter  $\nu$  shows stretched ellipses for the same combinations with  $kabs$  and  $S_1\text{-glut}_4$ .  $S_1\text{-liver}$  and all other parameters not included in appendix D.1 or D.2 show heavily stretched ellipses for combinations with  $kabs$ ,  $p_4$ , and  $S_1\text{-glut}_4$ . The same holds when a different insulin profile (dataset 2) is used.

Model 2 is examined by the model 2 model adjustment to know whether ingesting labelled glucose using the same experimental setup improves identifiability of  $S_1\text{-liver}$ . However,  $S_1\text{-liver}$  show heavily stretched ellipses for combinations with  $kabs$ ,  $p_4$ ,  $S_1\text{-glut}_4$  and  $Gb$ . Although model 3 shows less stretched ellipses than model 2 for combinations with  $kabs$ ,  $p_4$ ,  $S_1\text{-glut}_4$  and  $Gb$ ,  $S_1\text{-liver}$  remains a poor-identifiable parameter.

Although a priori global identifiability shows identifiability of  $beta$  and  $k$  in all possible combinations with  $kabs$ ,  $p_4$ ,  $S_1\text{-glut}_4$  and  $Gb$  in model 3, stretched ellipses are shown for all possible combination in appendix D.3.

In all cases that no noise is added, parameters are estimated exactly (unbiased parameters). By adding a  $1/\text{SNR}$  of 5% white noise to the output signal, bias was introduced in the estimation of parameters. However, parameter estimations are all close to the exact value (not shown in appendix D).

### 5.2.3 A Priori Parameters Sensitivity

The a priori parameters sensitivity is calculated using the first and the second data set described in section 5.1.2/ appendix C with added white noise having a  $1/\text{SNR}$  of 0%, 5% and 10%, respectively. The a priori parameters are varied one by one by  $\pm 5$ , 10, 20 and 30 %. The initial values of the identifiable parameters used in the estimation algorithm are set to those which showed largest bias in the relative worst case bias test in the case of a  $1/\text{SNR}$  of 0% white noise (section 5.3). The results shown in appendix E, shows the best possible variance for each identifiable parameter when the a priori parameters varies form the true value used.

Appendix E shows that for all estimated parameters,  $Ib$ ,  $Gb$ ,  $beta$  and  $k$  are highly sensitivity to variations of the true value among population. Parameter  $p_2$  only shows highly sensitivity for parameter  $S_1\text{-glut}_4$ . The remaining parameters  $p_5$ ,  $S_C$  and  $S_1\text{-liver}$  are insensible. An exception occurs for  $S_1\text{-liver}$  which shows a quite high sensitivity when white noise is added with a  $1/\text{SNR}$  of 10%.

### 5.3 Parameter Estimation

The cost function for ML is shown in (35) where  $\sigma_G^2, \sigma_{G'}^2$  are the variance of measurement errors in plasma glucose  $G(t)$  and interstitial glucose  $G'(t)$ .

$$J(\theta, i) = \frac{\sum_i (G(t_i) - G_{vm}(t_i, \theta_{fix}, \theta_{est}))^2}{2\sigma_G^2} + \frac{\sum_i (\overline{G'(t_i)} - \overline{G'_m}(t_i, \theta_{fix}, \theta_{est}))^2}{2\sigma_{G'}^2} \quad (35)$$

A priori information is available about the quality of the measurements of glucose and insulin plasma and interstitial glucose specified by the manufacturer of the measurement equipment or the lab where the samples are analyzed as stated in section 4.1.

The relative worst case bias is first calculated using the first and the second data set described in section 5.1.2 / appendix C with added white noise having a 1/SNR of 0%, (2.5%), 5% and 10%, respectively. The initial values of the identifiable parameters used in the estimation algorithm are varied between +/- 50 % using steps of 10%. The results shown in table 3, shows the relative worst case bias for each identifiable parameter.

1/SNR (%)	Insulin profile 1				Insulin profile 2			
	kabs	v	p4	SiGlut4	kabs	v	p4	SiGlut4
0	3.31	3.76	2.51	2.49	2.29	3.36	2.53	2.63
5	1.18	2.64	2.46	3.66	0.412	5.95	5.28	6.53
10	2.40	6.26	6.19	4.43	0.34	13.0	10.5	12.4

1/SNR (%)	Insulin profile 1	Insulin profile 2
	SiCap	SiCap
0	$3.00 \cdot 10^{-3}$	0.201
2.5	0.351	1.21
5	5.09	4.09
10	31.5	39.5

Table 3: Overview of the worst case bias of all identifiable parameters using synthetic data for two different insulin profiles (data sets 1 and 2, respectively, appendix b) with added white noise having a 1/SNR of 0, (2.5), 5 and 10%

Table 3 shows that all estimated parameters suffer from bias in all cases. All estimated parameters shows a low variance in all cases. (The initial values of the identifiable parameters in the case of a 1/SNR of 0% white noise which showed largest relative worst case bias are for the first dataset  $1.4 \cdot kabs$ ,  $1.4 \cdot v$ ,  $1.4 \cdot p$   $S_{I-cap}$ ,  $1.5 \cdot S_{I-glut4}$  and  $1.3 \cdot S_{I-cap}$ , for the second dataset  $0.5 \cdot kabs$ ,  $0.5 \cdot v$ ,  $0.5 \cdot p4$ ,  $0.5 \cdot S_{I-glut4}$  and  $0.6 \cdot S_{I-cap}$ .)

Secondly, the relative worst case bias is calculated using the third, fourth, fifth and sixth data set described in section 5.1.2/ appendix C with added white noise having a 1/SNR of 0%, 5% and 10%, respectively. The results are shown for datasets third and fourth in table 3 and for datasets fifth and sixth in table 4.



1/SNR (%)	Insulin profile 1				Insulin profile 2			
	kabs	v	p4	SiGlut4	kabs	V	p4	SiGlut4
0	18.2	17.1	16.6	4.89	16.5	20.0	19.7	12.8
5	17.4	28.1	16.6	24.2	24.7	23.1	25.4	5.20
10	20.6	38.8	36.4	48.9	60.1	18.4	23.8	10.5

1/SNR (%)	Insulin profile 1				Insulin profile 2			
	kabs	v	p4	SiGlut4	kabs	V	p4	SiGlut4
0	28.3	27.5	29.9	13.0	8.52	8.09	30.8	4.68
5	1.18	9.41	69.2	18.0	10.9	9.39	49.9	20.8
10	20.3	9.69	52.2	35.5	11.1	11.2	52.4	20.9

Table 4: Overview of the worst case bias of all identifiable parameters using synthetic data for two different insulin profiles and two different sample schedules (data sets 3, 4, 5 and 6, respectively, appendix b) with added white noise having a 1/SNR of 0, 5 and 10%

Table 4 shows for all estimated parameters a higher variance for each estimated parameter than by using the first and second dataset, but still acceptable. However, table 4 shows a lower variance for all estimated parameters in the case of a 1/SNR of 0% and 5% than by using the third and fourth dataset but still higher than by using the first and second dataset.

## 5.4 Optimal Experiment Design

### 5.4.1 Optimal Input Shaping

The optimal dosis was calculated by varying the input dose  $DS$  in the range of 1 gram to 100 gram in steps of 1 gram using the first and the second data set described in 5.1.2/ appendix C with added white noise having a 1/SNR of 0%, 5% and 10%, respectively. The initial values of the identifiable parameters used in the estimation algorithm were set to those which showed largest bias in the worst biased test in the case of a 1/SNR of 0% white noise (section 5.3).

If the relative worst bias of each estimated parameter was lower than 10% and did not increase for an increase in glucose dosis, this *minimum* glucose input was said to be optimal. The results are shown in table 5.

1/SNR (%)	Insulin profile 1	Insulin profile 2
	Amount of glucose [g]	Amount of glucose [g]
0	1	1
5	33	33
10	59	78

Table 5: Optimal dosis using synthetic data for two different insulin profiles (data sets 1, 2, respectively, appendix B) with added white noise having a 1/SNR of 0, 5 and 10%

## 6 Discussion and Suggestion

The goal of this study was to investigate and validate a new oral glucose minimal model describing jointly the effects of Glut-4 translocation, the recruitment of muscle capillaries and the effects of impairments of the inhibition of hepatic glucose production using existing minimal models in literature and modifying them using recent insights in the mechanism by which insulin regulates glucose uptake by muscle cells or adipose tissues. The new oral glucose minimal model was to be identified in all its aspects (a priori and a posteriori identifiability, a priori parameter sensitivity and to perform optimal experiment design).

Three oral glucose minimal models have been developed. The first model was developed to estimate the rate constant of glucose absorption from the gut into blood plasma ( $k_{abs}$ ), to estimate the efficacy of insulin to stimulate its own transport from blood plasma into interstitium by capillary recruitment ( $S_I\text{-cap}$ ), to estimate the efficacy of insulin to stimulate glucose transport from blood plasma into interstitium ( $p_4$ ), to estimate the efficacy of interstitial insulin to stimulate glucose clearance into muscle by Glut-4 translocation ( $S_I\text{-glut}_4$ ) and finally, to estimate the plasma glucose distribution volume per unit of body weight ( $\nu$ ). The second model was developed to estimate the previous parameters, but also to estimate the efficacy of insulin to inhibit hepatic production and stimulate glucose uptake by liver ( $S_I\text{-liver}$ ) by including ingested labelled glucose. The third model was an alternative for the second model since model 3 enriches blood plasma with labelled glucose through injecting labelled glucose instead of ingesting labelled glucose.

After developing the three oral glucose minimal models, a priori global identifiability analysis proved that with the models structure used, these estimations were possible. However, more information was acquired when choosing model 3, since model 3 could also estimate  $\beta$ , the variable of the power exponential curve denoting the velocity of emptying of the gut. This was obvious since extra data was available to estimate  $\nu$  by the infusion of labelled glucose.

A posteriori identifiability analysis showed, for all possible combinations of parameters  $k_{abs}$ ,  $p_4$ ,  $S_I\text{-glut}_4$  and  $G_b$ , contour plots with narrow ellips that were steep centered at the supposed true values of the parameters (global minima) using two different insulin profiles. Since  $G_b$  could be measured, this parameter was set a priori in order to not influence negatively the parameter estimation of the other unknown parameters. Parameter  $\nu$  showed stretched ellipses when estimated together with parameters  $k_{abs}$  or  $S_I\text{-glut}_4$  indicating low accuracy and less reliability as was seen when the relative worst bias was calculated. A problem occurs if parameter  $S_I\text{-liver}$  was estimated since all three models showed heavily stretched ellipses for combinations of  $k_{abs}$ ,  $p_4$ , and  $S_I\text{-glut}_4$ . Heavily stretched ellipses indicate non-identifiable parameters. Parameter  $S_I\text{-liver}$  was non-identifiable because  $p_4 \gg S_I\text{-liver}$  in (26).

Further, the a priori parameters sensitivity was calculated using two different insulin profiles. All estimated parameters,  $I_b$ ,  $G_b$ ,  $\beta$  and  $k$  showed highly sensitivity to variations of the true value among population. Since  $I_b$  and  $G_b$  could be measured, this was not a problem. On the other hand, high a priori parameter sensitivity of parameters  $\beta$  and  $k$  was a real problem. A priori global identifiability showed identifiability of either  $\beta$  or  $k$ , however, analyzing the a posteriori identifiability rejected this possibility. Good estimates of  $k_{abs}$  and  $k$  are available in literature [Schirra 1996], however, study [J.D. Elashoff 1982] shows that humans who have undergone an operation in the stomach can be modelled by changing parameter  $\beta$ . Hence, variations of  $\beta$  among populations exist.  $\beta$  or  $k$  could be estimated by measuring the content of glucose in the gut or by using high(er) concentrations of labelled glucose. Parameter  $p_2$  showed only highly sensitivity for parameter  $S_I\text{-glut}_4$ . Estimates of  $p_2$  are

available in literature e.g. [Toffolo 2003]. The bias of  $S_I\text{-glut}_4$  could be lowered by using the open-flow microperfusion technique [Bodenlenz 2005] instead of the microdialysis technique for measurements of interstitial glucose  $\overline{G_m(t)}$ . The open-flow microperfusion technique makes faster sampling of interstitial glucose  $\overline{G_m(t)}$  possible than the microdialysis technique. The remaining parameters  $p_5$ ,  $S_G$  and  $S_I\text{-liver}$  were insensible for variation of the a priori identifiable parameters. An exception occurred for  $S_I\text{-liver}$  that showed a quite high sensitivity when noise was added with a  $1/\text{SNR}$  of 10% to the output signals. However, a maximal  $1/\text{SNR}$  of 5 % was present in the measured outputs using the microdialysis technique.

A remark could be made about the identifiability of  $S_I\text{-cap}$ .  $S_I\text{-cap}$  could be identified separately if the interstitial insulin  $G'(t)$  profile was measured and  $p_2$  was known a priori. Unfortunately, measurements of interstitial insulin  $G'(t)$  were not available. However, the interstitial insulin profile could be estimated after estimating  $S_I\text{-glut}_4$ . In this case the variance of  $S_I\text{-cap}$  depends on a summation of two parts. One part is its own variance after estimating it from both the measured plasma insulin profile and the estimated interstitial insulin. The other part is non-linear and depends on the variance of  $S_I\text{-glut}_4$ .

The studied identifiability agreed with the found relative worst case bias. A relative worst case bias of maximal 6.5 % was achieved for all estimated parameters using a  $1/\text{SNR}$  of 5% added white noise. If a  $1/\text{SNR}$  of 10% white noise was added, a maximal relative worst case bias of 13% was achieved. If no noise was added, a maximal relative worst case bias of 3.76% was achieved indicating bad working of the minimalization algorithm used to minimize (15). Important to note is that measurements of interstitial glucose  $G'(t)$  had been undermodelled. The interstitial glucose  $G'(t)$  samples were modelled by calculating the mean of  $\overline{G_m(t)}$  over 30 minutes by summing up the values of  $G_m'(t)$  with intervals set to one-fifth of the smallest experimental time constant used in the model and dividing it by the number of intervals. In fact, subsequent samples of interstitial glucose  $\overline{G_m(t)}$  are influenced by each other since the samples are collected at the outlet of the catheter without stopping the inlet of new interstitial glucose, causing mixing of subsequent interstitial glucose samples. This effect was not taken into account since the behaviour of mixing is still unknown.

The optimal dosis was calculated by varying the input doses  $DS$  in the range of 1 gram to 100 gram in steps of 1 gram using two different insulin profiles and using sequences of added white noise with a  $1/\text{SNR}$  of 0%, 5% and 10%. A complication occurred when  $DS$  was varied. If  $DS$  vary, this also implies a different insulin profile. However, the same insulin profile was used during all variations of  $DS$  since an insulin profile of glucose ingestion other than 75 or 100 gram was not available. It is not common to have such an OGTT. This complication set doubts to the obtained results. This *minimum* glucose input was said to be optimal if the relative worst bias of each estimated parameter was lower than 10% and did not increase for an increase in glucose doses. For each  $1/\text{SNR}$  a different optimum glucose input was obtained. For a  $1/\text{SNR}$  of 0% of added white noise, all glucose doses were optimal. For a  $1/\text{SNR}$  of 5% of added white noise an optimal glucose doses of 33 gram was obtained and for a  $1/\text{SNR}$  of 10% of added white noise, 78 gram was obtained. It could be concluded that the doses of glucose should be as high as possible.

Due to limited time issues, the optimal sample schedule algorithm was not applied. Instead of this, a different test was applied: The relative worst case bias was calculated for two extra

different sample schedules (appendix C). The first extra sample schedule (the conventional sample schedule) is used as standard in many studies [Sjostrand 2005], [Wagenmakers 2006]. For the second extra sample schedule, a new sample schedule was developed which takes samples of glucose and insulin plasma during events when most changes take places in the insulin profile. This is often, during the first 60 minutes after glucose ingestion. This second extra sample schedule showed a lower variance for all estimated parameters in the case of a  $1/\text{SNR}$  of 0% and 5% of added white noise than using the first extra sample schedule. This is obvious, because the second extra sample schedule has samples of glucose and insulin plasma during events when the most changes takes places in the insulin profile. Hence, it is very interested to find the optimal sample schedule to obtain the lowest possible relative worst bias for the estimated parameters. In both cases, the relative worst case bias was higher than the best relative worst case bias calculated in section 5.3 because fewer samples are taken in both extra sample schedules. It could be discussed if an optimal samples schedule could be found, since great variety exists among measured glucose profiles.

A remark could be made about the optimal sample schedule algorithm developed here to calculate the optimal sample schedule. The optimal sample schedule could use the Fisher information matrix as indication how optimal a samples schedule is. At the start of the algorithm a sample schedule with many samples is available which showed, as in section 5.3, low relative worst case bias. However, as the algorithm progress, the *current* optimum sample schedule has fewer samples than the *initial* sample schedule, introducing more bias in the estimation of parameters. Hence, the conditions of Fisher information matrix are not satisfied, and the relative worst case bias technique must be used instead. A drawback of the relative worst case bias technique is the processing time which is extremely large. But if the search of the optimum sample schedule progress well, the sample schedule should always show low bias and the Fisher information matrix could be used. A dilemma that must be investigated, before using the optimal sample schedule algorithm.

A different remark can be made about the choice of first calculating the optimal input doses before searching for the optimal sample schedule or quite the reverse. Since the optimal samples is selected in the range (domain) of the conventional samples, it is obvious to calculate first the optimal input doses for the conventional samples and then to reduce this set of samples obtaining the optimal sample schedule.

## 7 Conclusion

The goal of this study was to investigate possible impairments of insulin resistance in type 2 diabetes. Model 1 could be used to investigate whether there are impairments in Glut-4 translocation and impairments in the recruitment of muscle capillaries during physiological insulin concentrations that. The model did not take into account insulin production by the pancreas, instead of this the insulin concentration profile in blood plasma was measured which insulin was produced by the pancreas. Model 1 could not discriminate impairment of hepatic glucose production.

The following parameters can be estimated using model 2 and measuring glucose blood plasma, insulin blood plasma, basal glucose level, basal insulin level and interstitial glucose using the microdialysis technique: The rate constant of glucose appearance from the gut into blood plasma, the efficacy of insulin to stimulate its own transport from blood plasma into interstitium by capillary recruitment, the efficacy of insulin to stimulate glucose transport from blood plasma into interstitium, the efficacy of interstitial insulin to stimulate glucose

clearance into muscle by Glut-4 translocation and the plasma glucose distribution volume per unit of body weight. This was the first time that these parameters were estimated jointly to understand and quantify different potential causes (mechanism of Glut-4 translocation and recruitment of muscle capillaries) of insulin resistance in type 2 diabetes during an OGTT using a physiological model of glucose appearance in blood plasma. This model refines earlier developed models.

Using a minimum glucose doses of 78 gram during an OGTT and having a  $1/\text{SNR}$  of 10%, parameters were estimated with a maximum variance of  $\pm 13\%$  if each minute a sample of insulin and glucose blood plasma and each 30 minutes a sample of interstitial glucose were taken during the first 240 minutes after glucose ingestion. If the  $1/\text{SNR}$  is 5%, parameters were estimated with a maximum variance of  $\pm 6.5\%$ . An exception holds for the parameter which denotes the efficacy of insulin to stimulate its own transport from blood plasma into interstitium by capillary recruitment which can be slight higher. This is due to the fact that this parameter also depends in a still unknown non-linear way on the precision of the efficacy of interstitial insulin to stimulate glucose clearance into muscle by Glut-4 translocation. If fewer samples are taken, it is advised to take samples when most dynamics takes places in glucose kinetics or to use the optimal sample schedule algorithm developed in this study.

All a priori identifiable parameters used in model 1 except  $\beta$  and  $k$  are insensitive for the estimated parameters when having a  $1/\text{SNR}$  of 0%, 5% and 10% of white noise and using model 1 and the experimental setup described in this study. Varying the true value of all the a priori identifiable parameters (except  $\beta$  and  $k$ ) found in literature with  $\pm 30\%$  in steps of 5% resulted in a maximum variance of  $\pm 12\%$  in the estimation of the identifiable parameters. On the other hand  $\beta$  and  $k$  showed a maximum variance of respectively 241% and 195%. Although, having this high sensitivity for the a priori identifiable parameters  $\beta$  and  $k$ , the description of glucose appearance with model 1 is better than earlier developed models found in literature. The earlier developed models were based on interpolating glucose appearance in blood plasma instead of using physiological parameters to model glucose appearance in blood plasma.

## References

- [Audoly 2001] Audoly, S., G. Bellu, L. D'Angio, M.P. Saccomani and C. Cobelli, "Global identifiability of nonlinear models of biological systems," *IEEE Transactions on Biomedical Engineering*, Vol. 48, No. 1 (2001), p. 55-65.
- [Bar 1978] Bar, R.S., J.C. Hoak and M.L. Peacock, "Insulin receptors in human endothelial cells. Identification and characterization," *Journal of Clinical Endocrinology and Metabolism*, Vol. 47(1978), No. 3, p. 699-702.
- [Brunner 1998] Brunner, F., and T.C. Wascher, "Contribution of the endothelium to transcapillary insulin transport in rat isolated perfused hearts," *Diabetes*, Vol. 47(1998), No. 7, p. 1127-1134.
- [Bergman 1979] Bergman, R.N., Y.Z. Ider, C.R. Bowden. and C. Cobelli, "Quantitative estimation of insulin sensitivity," *American Journal of Physiology*, Vol. 236(1979), p. E667-E677.
- [Bergman 1981] Bergman, R.N., L.S. Phillips and C. Cobelli, "Physiologic evaluation of factors controlling glucose tolerance in man. Measurement of insulin sensitivity and  $\beta$ -cell glucose sensitivity from the response to intravenous glucose," *Journal of Clinical Investigation*, Vol. 68(1981), No. 6, p. 1456-1467.
- [Bergman 1981] Bergman, R.N., L.S. Phillips and C. Cobelli, "Physiologic evaluation of factors controlling glucose tolerance in man. Measurement of insulin sensitivity and  $\beta$ -cell glucose sensitivity from the response to intravenous glucose," *Journal of Clinical Investigation*, Vol. 68(1981), No. 6, p. 1456-1467.
- [Bodenlenz 2005] Bodenlenz, M., L.A. Schaupp, L.A., T. Druml, R. Sommer, A. Wutte, H. C. Schaller, F. Sinner, P. Wach and T.R. Pieber, T.R., "Measurement of interstitial insulin in human adipose and muscle tissue under moderate hyperinsulinemia by means of direct interstitial access," *American Journal of Physiology - Endocrinology and Metabolism*, Vol. 289, No. 2(2005), p. E296-E300.
- [Bergman 2003] Bergman, R.N., "Editorial: Insulin Action and Distribution of Tissue Blood Flow," *Journal of Clinical Endocrinology and Metabolism*, Vol. 88, No. 10(2003), p 4556-4558.
- [Breda 2001] Breda, E., M.K. Cavaghan, G. Toffolo, K.S. Polonsky and C. Cobelli, "Oral glucose tolerance test minimal model indexes of  $\beta$ -cell function and insulin sensitivity," *Diabetes*, Vol. 50(2001), No. 1, p. 150-158.
- [Breda 2002] Breda, E., G. Toffolo, K.S. Polonsky and C. Cobelli, "Insulin release in impaired glucose tolerance: Oral minimal model predicts normal sensitivity to glucose but defective response times," *Diabetes*, Vol. 51(2002), No. Suppl.
- [Brunner 1998] Brunner, F., and T.C. Wascher, "Contribution of the endothelium to transcapillary insulin transport in rat isolated perfused hearts," *Diabetes*, Vol. 47(1998), No. 7, p. 1127-1134.
- [Buchberger 2001] Buchberger, B., "Gröbner bases and system theory," *Multidimensional Systems and Signal Processing*, Vol. 12, No. 3-4(2001), p. 223-251.
- [Castillo 1991] Castillo, C.E. and S. Lillioja, "Peripheral lymphatic cannulation for physiological analysis of interstitial fluid compartment in humans," *American Journal of Physiology - Heart and Circulatory Physiology*, Vol. 261(1991), No. 4 30-4, p. H1324-H1328.
- [Castillo 1994] Castillo, C., C. Bogardus, R.N. Bergman, P. Thuillez and S. Lillioja, "Interstitial insulin concentrations determine glucose uptake rates but not insulin resistance in lean and obese men," *Journal of Clinical Investigation*, Vol. 93(1994), No. 1, p. 10-16.
- [Caumo 1993] Caumo A and C. Cobelli. "Hepatic glucose production during the labeled IVGTT: estimation by deconvolution with a new minimal model", *American Journal of Physiology - Endocrinology and Metabolism*, Vol. 264, No. 5 27-5(1993), p. E829-E841.
- [Caumo 2000] Caumo, A., R.N. Bergman and C. Cobelli, "Insulin sensitivity from meal tolerance tests in normal subjects: A minimal model index," *Journal of Clinical Endocrinology and Metabolism*, Vol. 85(2000), No. 11, p. 4396-4402.
- [Caumo 2004] Caumo, A., and L. Luzi, "First-phase insulin secretion: Does it exist in real life? Considerations on shape and function," *American Journal of Physiology - Endocrinology and Metabolism*, Vol. 287(2004), No. 3 50-3, p. E371-E385.
- [Clerk 2006] Clerk, L. H., M. A., Vincent, L. A. Jahn, Z. Liu, J. R. Lindner and E. J. Barrett, "Obesity Blunts Insulin-Mediated Microvascular Recruitment in Human Forearm Muscle", *Diabetes*, Vol. 55, No. 5. (2006), p. 1436-1442.
- [Cobelli 1988] Cobelli, C., and K. Thomaseth, "On optimality of the impulse input for linear system identification," *Mathematical Biosciences*, Vol. 89, No. 2(1988), p. 127-133.
- [Cobelli 1999] Cobelli, C., A. Caumo and M. Omenetto, "Minimal model SG overestimation and SI underestimation: Improved accuracy by a Bayesian two-compartment model," *American Journal of Physiology - Endocrinology and Metabolism*, Vol. 277, No. 3 40-3(1999), p. E481-E488.
- [Cretti 2001] Cretti, A., M. Lehtovirta, E. Bonora, B. Brunato, M. G. Zenti, F. Tosi, M. Caputo, B. Caruso, L. C. Groop, M. Muggeo, and R. C. Bonadonna, "Assessment of  $\beta$ -cell function during the oral glucose tolerance test by a minimal model of insulin secretion," *European Journal of Clinical Investigation*, Vol. 31(2001), No. 5, p. 405-416.

[Dalla Man 5-2002] Dalla Man, C.D., A. Caumo and C. Cobelli, "The oral glucose minimal model: estimation of insulin sensitivity from a meal test," *IEEE Transactions on Biomedical Engineering*, Vol. 49(2002), No. 5, p. 419-429.

[Dalla Man 10-2002] Dalla Man, C., G. Toffolo, and C. Cobelli, "Glucose kinetics during a meal: One vs two compartment minimal model," Annual International Conference of the IEEE Engineering in Medicine and Biology - Proceedings, Vol. 3 (2002), p. 2222-2223.

[Damen 2005] Damen A., "Physiological processes and parameter estimation," Lecture notes, Eindhoven University of Technology, The Netherlands. 2005.

[Eaton 1980] Eaton, R.P., R.C. Allen, D.S. Schade, K.M. Erickson and J. Standefer, "Prehepatic insulin production in man: Kinetic analysis using peripheral connecting peptide behavior," *Journal of Clinical Endocrinology and Metabolism*, Vol. 51, No. 3, p. 520-528.

[Ehrmann 2002] Ehrmann, D.A., E. Breda, M.K. Cavaghan, S. Bajramovic, J. Imperial, G. Toffolo, C. Cobelli, and K.S. Polonsky, "Insulin secretory responses to rising and falling glucose concentrations are delayed in subjects with impaired glucose tolerance," *Diabetologia*, Vol. 45(2002), No. 4, p. 509-517.

[Elashoff 1982] Elashoff, J.D., T.J. Reedy and J.H. Meyer, "Analysis of gastric emptying data," *Gastroenterology*, Vol. 83(1982), No. 6, p. 1306-1312.

[Gudbjörnsdóttir 2003] Gudbjörnsdóttir, S., M. Sjöstrand, L. Strindberg, J. Wahren and P. Lönnroth, "Direct Measurements of the Permeability Surface Area for Insulin and Glucose in Human Skeletal Muscle," *Journal of Clinical Endocrinology and Metabolism*, Vol. 88, No. 10(2003), p. 4559-4564.

[Hamilton-Wessler 2002] Hamilton-Wessler, M., M. Ader, M.K. Dea, D. Moore, M. Loftager, J. Markussen and R.N. Bergman, "Mode of transcapillary transport of insulin and insulin analog NN304 in dog hindlimb: Evidence for passive diffusion," *Diabetes*, Vol. 51(2002), No. 3, p. 574-582.

[Herkner 2003] Herkner, H., N. Klein, C. Joukhadar, E. Lackner, H. Langenberger, M. Frossard, C. Bieglmayer, O. Wagner, M. Roden and M. Müller, "Transcapillary insulin transfer in human skeletal muscle," *European Journal of Clinical Investigation*, Vol. 33(2003), No. 2, p. 141-146.

[Iwashita 2001] Iwashita, S., K. Yanagi, N. Ohshima and M. Suzuki, "Insulin increases blood flow rate in the microvasculature of cremaster muscle of the anesthetized rats," *In Vivo*, Vol. 15, No. 1(2001), p. 11-15.

[Jansson 1993] Jansson, P.-A.E., J.P. Fowelin, H.P. Von Schenck, U.P. Smith and P.N. Lönnroth, "Measurement by microdialysis of the insulin concentration in subcutaneous interstitial fluid: Importance of the endothelial barrier for insulin," *Diabetes*, Vol. 42(1993), No. 10, p. 1469-1473.

[King 1985] King, G.L. and S.M. Johnson, "Receptor-mediated transport of insulin across endothelial cells," *Science*, Vol. 227(1985), No. 4694, p. 1583-1586.

[Landaw 1982] Landaw, E. M., "Optimal multicompartamental sampling designs for parameter estimation: Practical aspects of the identification problem," *Mathematics and Computers in Simulation*, Vol. 24, No. 6(1982), p. 525-530.

[Lauritzen 2006] H. P.M.M. Lauritzen, T. Ploug, C. Prats, J. M. Tavaré, and H. Galbo, "Imaging of Insulin Signaling in Skeletal Muscle of Living Mice Shows Major Role of T-Tubules," *Diabetes*, Vol. 55, No. 5 (2006), p. 1300-1306.

[Lönnroth 1987] Lönnroth, O., P.-A. Jansson and U. Smith, "A microdialysis method allowing characterization of intercellular water space in humans," *American Journal of Physiology - Endocrinology and Metabolism*, Vol. 253, No. 2 (1987), p 16/2.

[Lönnroth 1997] Lönnroth, P., "Microdialysis in adipose tissue and skeletal muscle," *Hormone and Metabolic Research*, Vol. 29, No. 7 (1997), p. 344-346.

[Mari 2002] Mari, A., O. Schmitz, A. Gastaldelli, T. Oestergaard, B. Nyholm, and E. Ferrannini, "Meal and oral glucose tests for assessment of  $\beta$ -cell function: Modeling analysis in normal subjects," *American Journal of Physiology - Endocrinology and Metabolism*, Vol. 283(2002), No. 6 46-6, p. E1159-E1166.

[Mori 1979] Mori, F., and J.J. De Stefano, "Optimal nonuniform sampling interval and test-input design for identification of physiological systems from very limited data," *IEEE Transactions on Automatic Control*, Vol. AC-24, No. 6(1979), p.893-900.

[Natalucci 2003] Annual International Conference of the IEEE Engineering in Medicine and Biology, Cancun, Mexico, 17-21 September 2003, Natalucci, S., F. Di Nardo, P. Staffolani, C. De Marzi, P.

[Peacock 1982] Peacock, M.L., R.S. Bar and J. Goldsmith, "Interactions of insulin with bovine endothelium," *Metabolism: Clinical and Experimental*, Vol. 31(1982), No. 1, p. 52-56.

[Porter 1997] Porter, J.P., I.G. Joshua, D. Kabithe and H.S. Bokil, "Vasodilator effect of insulin on the microcirculation of the rat cremaster muscle," *Life Sciences*, Vol. 61, No. 7(1997), p. 673-684.

[Regittinig 2003] Regittinig, W., M. Ellmerer, G. Fauler, G. Sendhofer, Z. Trajanoski, H.-J. Leis, L. Schaupp, P. Wach and T.R. Pieber, "Assessment of transcapillary glucose exchange in human skeletal muscle and adipose tissue," *American Journal of Physiology - Endocrinology and Metabolism*, Vol. 285, No. 2 48-2(2003), p. E241-E251.

- [van Riel 2006] van Riel, N.A.W., and E.D. Sontag, "Parameter estimation in models combining signal transduction and metabolic pathways: The dependent input approach" *IEEE Proceedings: Systems Biology*, Vol. 153, No.4(2006), p. 263-274.
- [Saccomani 2001] Saccomani, M.P., S. Audoly, G. Bellu and L. D'Angio, "A new differential algebra algorithm to test identifiability of nonlinear systems with given initial conditions," *Proceedings of the IEEE Conference on Decision and Control*, Vol. 4(2001), p. 3108-3113.
- [Saccomani 2002] Saccomani, M.P., S. Audoly and L. D'Angio, "Parameter identifiability of nonlinear systems: The role of initial conditions," *Automatica*, Vol. 39, No. 4(2003), p. 619-632.
- [Salveti 2002] Salvetti, F., P. Cecchetti, D. Janigro, A. Lucacchini, L. Benzi and C. Martini, "Insulin permeability across an in Vitro dynamic model of endothelium," *Pharmaceutical Research*, Vol. 19(2002), No. 4, p. 445-450.
- [Schirra 1996] Schirra, J., M. Katschinski, C. Weidmann, T. Schäfer, U. Wank, R. Arnold and B. Göke, "Gastric emptying and release of incretin hormones after glucose ingestion in humans," *Journal of Clinical Investigation*, Vol. 97(1996), No.1, p. 92-103.
- [Sjöstrand 1999] Sjöstrand, M., A. Holmäng and P. Lönnroth, "Measurement of interstitial insulin in human muscle," *American Journal of Physiology - Endocrinology and Metabolism*, Vol. 276(1999), No. 1 39-1, p. E151-E154.
- [Sjöstrand 2002] Sjöstrand, M., S. Gudbjörnsdottir, A. Holmäng, L. Lönn, L. Strindberg and P. Lönnroth, "Delayed transcapillary transport of insulin to muscle interstitial fluid in obese subjects," *Diabetes*, Vol. 51(2002), No. 9, p. 2742-2748.
- [Sjöstrand 2005] Sjöstrand, M., S. Gudbjörnsdottir, L. Strindberg and P. Lönnroth, "Delayed transcapillary delivery of insulin to muscle interstitial fluid after oral glucose load in obese subjects," *Diabetes*, Vol. 54(2005), No. 1, p. 152-157.
- [Sontag 1998] Sontag, E.D., "Mathematical control theory: the effluence of R.E. Kalman," *Springer*, 2<sup>nd</sup> ed. (1998).
- [Steil 1996] Steil, G.M., M. Ader, D.M. Moore, K. Rebrin, and R.N. Bergman, "Transendothelial insulin transport Is not saturable in vivo: No evidence for a receptor-mediated process" *Journal of Clinical Investigation*, Vol. 97(1996), No. 6, p. 1497-1503.
- [Steil 2003] Steil, G.M., K. Rebrin, R. Janowski, C. Darwin, and M.F. Saad, "Modeling  $\beta$ -Cell Insulin Secretion - Implications for Closed-Loop Glucose Homeostasis," *Diabetes Technology and Therapeutics*, Vol. 5(2003), No. 6, p. 953-964.
- [Toffolo 1980] Toffolo, G., R.N. Bergman, D.T. Finegood, C.R. Bowden and C. Cobelli, "Quantitative estimation of beta cell sensitivity to glucose in the intact organism. A minimal model of insulin kinetics in the dog," *Diabetes*, Vol 29(1980), No.12, p. 979-990.
- [Toffolo 1995] Toffolo, G., F. De Grandi, and C. Cobelli, "Estimation of  $\beta$ -cell sensitivity from intravenous glucose tolerance test C-peptide data: Knowledge of the kinetics avoids errors in modeling the secretion," *Diabetes*, Vol. 44(1995), No. 7, p. 845-854.
- [Toffolo 2003] Toffolo, G., and C. Cobelli, "The hot IVGTT two-compartment minimal model: An improved version," *American Journal of Physiology - Endocrinology and Metabolism*, Vol. 284, No. 2 47-2(2003), p. E317-E321.
- [Wagenmakers 2006] Prof A.Wagenmakers, Unpublished data, University of Birmingham 2006.
- [Vincent 2004] Vincent, M.A., L.H. Clerk, J.R. Lindner, A.L. Klibanov, M.G. Clark, S. Rattigan and E.J. Barrett, "Microvascular recruitment is an early insulin effect that regulates skeletal muscle glucose uptake in vivo," *Diabetes*, Vol. 53, No. 6 (2004), p. 1418-1423.
- [Vincent 2005] Vincent, M.A., L.H. Clerk, S. Rattigan, M.G. Clark and E.J. Barrett, "Active role for the vasculature in the delivery of insulin to skeletal muscle," *Clinical and Experimental Pharmacology and Physiology*, Vol. 32(2005), No. 4, p. 302-307.
- [Walter 1997] Walter, E., L. Pronzato and J. Norton, "Identification of parametric models : from experimental data," Paris : Masson, 1997.
- [Worthington 1997] Worthington, D.R.L., "Minimal model of food absorption in the gut," *Medical Informatics*, Vol. 22(1997), No. 1, p. 35-45.
- [Xianjin 2000] Li, X., D. Feng and K.-P.Wong, "A general algorithm for optimal sampling schedule design in nuclear medicine imaging," *Computer Methods and Programs in Biomedicine*, Vol. 65, No. 1, 2001, p. 45-59.
- [Yang 1989] Yang, Y.J., I.D. Hope, M. Ader and R.N. Bergman, "Insulin transport across capillaries is rate limiting for insulin action in dogs," *Journal of Clinical Investigation*, Vol. 84(1989), No. 5, p. 1620-1628.
- [Zhang 2004] Zhang, L., M.A. Vincent, S.M. Richards, L.H. Clerk, S. Rattigan, M.G. Clark and E.J. Barrett, "Insulin Sensitivity of Muscle Capillary Recruitment In Vivo", *Diabetes*, Vol. 53, No. 2(2004), p. 447-453.



[Zheng 2005] Zheng, Y.a and M.B. Zhao, "Modified minimal model using a single-step fitting process for the intravenous glucose tolerance test in Type 2 diabetes and healthy humans," *Computer Methods and Programs in Biomedicine*, Vol. 79(2005), No. 1, p. 73-79.

[Zijlstra 2004] Zijlstra, E., "Validation of the use of a minimal model of glucose metabolism during an oral test from both a physiological and an identification point of view," *Technische Universiteit Eindhoven*, 2004.

## **Modelling the insulin transport from blood plasma through the endothelium to reach the interstitium.**

Several studies have studied the mechanism of insulin transport from blood plasma through the endothelium to reach the interstitium concluding conflicting results: a saturable receptor-mediated or diffusion transport. A saturable receptor-mediated is possible since [R.S. Bar 1978] found receptors on cultured human endothelial cells obtained from human umbilical veins and [M.L. Peacock 1982] found receptors on cultured and isolated bovine endothelial cells obtained from pulmonary and systemic vessel.

Some *in vivo* studies have measured the insulin concentrations in the interstitium with the microdialysis technique [Lönnroth 1987, Lönnroth 1997] in human skeletal muscle of conscious healthy lean humans with no medication in (semi) supine position during an OGTT [H. Herkner 2003, M. Sjöstrand 2005] and during a CLAMP [M. Sjöstrand 1999, P.E. Jansson 1993]. Other studies have measured insulin concentration using the peripheral lymphatic cannulation technique [Castillo 1991] in hindlimb lymph of conscious healthy humans with a wide range of obesity and with no medication in (semi) supine position during a CLAMP [C. Castillo 1994] and with anesthetized healthy dogs during a CLAMP [M. Hamilton-Wessler 2002, G. M. Steil 1996]. Another study has measured insulin concentration in thoracic duct lymph with conscious healthy dogs during a CLAMP [Y.J. Yang 1989]. (In all lymph based studies, lymph fluid concentration is increased by massaging or saline injection.) No difference exists between the two different measurements sites, since [Y.J. Yang 1989, C. Castillo 1994] showed strong correlation and direct proportionality between insulin concentration in the hindlimb lymph near the human skeletal muscle and glucose uptake by human skeletal muscle. Only a delay time exists between insulin in the interstitium and insulin in hindlimb lymph due to the transport time needed between both places. From this, it can be assumed that insulin concentration in interstitium and hindlimb lymph also shows strong correlation and direct proportionality.

Saturable receptor-mediated transport of insulin can be shown by an increase of insulin gradient (or decrease of insulin ratio) between blood plasma and interstitium/lymph at higher insulin concentration. After all, an increase of insulin gradient (or decrease of insulin ratio) implies a decrease in insulin transport indicating a saturable receptor-mediated transport of insulin. But since changes in clearance of insulin by muscle cells affect the gradient, it is critical to assess this parameter if an increase in the gradient is to be interpreted as a decrease in transport. However, studies [Y.J. Yang 1989, C. Castillo 1994, H. Herkner 2003] show a strong correlation between glucose uptake and insulin concentrations in interstitium/lymph concluding that no saturation occurs in clearance of insulin by muscle cells. Hence, analyzing this gradient is significant for the mechanism of insulin transport through the endothelium.

After analyzing the discussed gradient in experimental data of several *in vivo* studies an interesting conclusion is drawn. The studies using insulin concentrations at physiological range (up to 600 pM in blood plasma) [Y.J. Yang 1989, H. Herkner 2003, C. Castillo 1994, M. Sjöstrand 2005] show a decreased gradient indicating saturable receptor-mediated transport. [P.E. Jansson 1993] shows at insulin concentrations of 3500 pM a decreased gradient indicating saturable receptor-mediated transport. The studies [G. M. Steil 1996, M. Hamilton-Wessler 2002] using insulin concentrations at pharmacologic range (more than 5000 pM in blood plasma) show an increased gradient indicating diffusion transport. As a unification of both conclusions, a saturable receptor-mediated insulin transport is considered under physiological conditions whereas a non-saturable insulin transport is considered at pharmacologic insulin concentrations.

*In vitro* study (cultured bovine aortic endothelial cells with the use of dual chamber, not exposed to a flow) [L. King 1985] at physiological range concludes a receptor-mediated transport of insulin through the endothelium. Another study *in vitro* (endothelial cells from rat hearts) [F. Brunner 1998] at physiological range concludes a diffusion process. However, [M.A. Vincent 2005] shows a different behavior of the endothelium of rats compared with the endothelium of humans. The insulin

concentration ratio between interstitium and blood plasma is around 80% in contrast to humans 40-50% [M.A. Vincent 2005, M. Sjöstrand 1999] or dogs 35-50% [M.A. Vincent 2005]. Hence, the endothelium in rats is not a good representation of the endothelium in humans. In vitro study (cultured endothelial cells in a hollow fiber apparatus and continuously exposed to a flow) [F. Salvetti 2002] at physiological range shows a decreased gradient at higher insulin concentrations. Since these studies are all in vitro, the conclusions drawn from them are taken less serious than in vivo studies. However, the conclusions are in agreement with in vivo conclusions.

Hence, the classic minimal model of Bergman [Bergman 1979] is only valid using insulin concentrations at physiological range. This is always the case during an OGTT.

Another interesting case to study, are possible delays. A significant delay about 20 minutes in the activation phase of transporting insulin from blood plasma to interstitium is seen in vivo studies [M. Sjöstrand 2005, M. Sjöstrand 2002, C. Castillo 1994, Y.J. Yang 1989, E. Jansson 1993] and in vitro study [F. Salvetti 2002]. The cause of this delay is not known yet. No delay is seen in the deactivation phase of transporting insulin from blood plasma to interstitium [Y.J. Yang 1989]. A small delay is seen between glucose uptake and lymph insulin for insulin binding to its cognate cell receptor [Y.J. Yang 1989].

## Modelling insulin that is secreted by pancreatic $\beta$ -cells via the liver into the portal vein.

The ability to control glucose production and utilization depends on insulin that is secreted by pancreatic  $\beta$ -cells via the liver, where insulin is decreased (extracted) by approximately 50%, into the portal vein. When the concentration of glucose in plasma increases rapidly, insulin is secreted by pancreatic  $\beta$ -cells in two phases: the first and second phase. The first 10 minutes (first phase) is a fast rise of insulin secretion. The next 20 minutes (second phase) is a gradually rise of insulin secretion which is directly related to the degree and duration of the stimulus [Caumo 2004]. Between the 70s and 80's several  $\beta$ -cell insulin secretion models were developed based on measurement of plasma insulin concentrations or measurement of c-peptide. These models can be added to the new oral glucose minimal model discussed in section 3 to estimate the plasma insulin profile instead of measuring the plasma insulin profile. Adding one of these models into the new oral glucose minimal model discussed in section 3 is also a closer step into a future automated portable continuous glucose monitoring system. First, models based on measurements of plasma insulin concentrations are given and secondly, models based on c-peptide measurements are given.

Toffolo proposed eight models tested on conscious healthy lean dogs by an IVGT [Toffolo 1980] using the minimal model [Bergman 1979]. The models assume that clearance of insulin is of the first order, the initial insulin peak represents a bolus loaded into insulin plasma after the glucose injection and the rate of the secondary rise in insulin is determined by the concentration of glucose in plasma above a specific threshold value. This model has the disadvantage that parameter estimation has to be done in two steps. First the insulin concentration is used as input data to estimate the parameters of the minimal model [Bergman 1979], secondly the recorded glucose data is used as input for the  $\beta$ -cell insulin secretion model. However, by the single-step fitting process [Zheng 2005] this handicap is resolved.

This proposed minimal model by Toffolo in 1980 is tested on healthy lean and obese humans by an IVGT [Bergman 1981] showing strong correlation with [Toffolo 1980]. This study also shows that lean lower tolerance humans is related to 77% diminished second phase responsivity ( $S_I$  remained unchanged) and that obese lower tolerance humans 60% diminished  $S_I$  (second phase remained unchanged).

Zheng introduced a modification of Toffolo's model [Zheng 2005] by the assumption that the insulin decay rate is not always a first-order process showing improved fitting (97.7%) than Toffolo's model in 1980. He also added a mathematical function for describing the endogenous insulin infusion rate. The model is shown in (b1) where  $\gamma$  [ $\text{IpM} \cdot \text{l}/(\text{mM} \cdot \text{min})$ ] is the rate of pancreatic release of insulin after the glucose injection,  $h$  [mM] is the pancreatic threshold value,  $t$  [min] is the time,  $n$  [ $(\text{IpM})^{1-m} \cdot \text{l}/\text{min}$ ] is the plasma insulin decay rate constant,  $u(t)$  [mU/mg  $\cdot$  min] is the endogenous insulin infusion rate,  $m$  stands for the  $m$ -th order processes and  $k$  [pM] is the initial plasma insulin concentration after the glucose bolus injection. Due to the assumption that the insulin decay rate is not always a first-order process equation is modified by (b2).

$$\dot{I}(t) = \begin{cases} \gamma \cdot [G(t) - h] \cdot t - n \cdot [I(t) - I_b]^m + u(t)/V & \text{if } G(t) > h \\ -n \cdot [I(t) - I_b]^m + u(t)/V & \text{if } G(t) \leq h \end{cases} \quad I(0) = k + I_b \quad (\text{b1})$$

$$\dot{I}'(t) = -p2 \cdot I'(t) + p2 \cdot S_I \cdot [I(t) - I_b]^m \quad I(0) = 0 \quad (\text{b2})$$

Steil introduced a new model [Steil 2003] which assumes a proportional component that reacts to the difference between plasma and basal glucose ( $P$ ), an integral component that adjusts basal delivery in proportion to hypo/hyperglycemia ( $I$ ) and a derivative component that responds to the rate of change in glucose plasma ( $D$ ). The model is test during a CLAMP on healthy humans showing good fitness. Furthermore, this model is especially designed for closed loop systems linking a glucose sensor with an insulin pump (an automated portable continuous glucose monitoring system) that includes stability and improved frequency characteristics/response. The model is shown in (b3, b4) where  $SR(t)$  [pM] is the  $\beta$ -cell insulin secretion rate,  $n$  [1/min] is the reciprocal of the insulin plasma decay rate constant,  $K_p$  [pmol $\cdot$ 1/min $\cdot$ 1/M] is the rate of  $\beta$ -cell insulin secretion,  $T_i$  [min] is the rate of proportional to integral release and  $T_D$  [Min] is the ratio of derivative to proportional release.

$$\dot{I}(t) = -n \cdot I(t) + \frac{SR(t)}{V} \quad (b3)$$

$$SR(t) = P(t) + I(t) + D(t) \quad SR(t) \geq 0$$

$$P(t) = K_p \cdot (G(t) - G_b)$$

$$\dot{I}(t) = K_p \cdot (G(t) - G_b) / T_i \quad I(0) = I_b \quad (b4)$$

$$D(t) = K_p \cdot T_D \cdot \dot{G}(t)$$

The test reveals that impaired glucose tolerance humans have a defect in the second phase as earlier stated.

Other models are based on the measurement of c-peptide [Eaton 1980] that is secreted in equal amounts as insulin with advantages that c-peptide is hardly extracted by the liver and its kinetics are linear. A disadvantage, from a qualitative standpoint, of models based on c-peptide is that the measurement of c-peptide is worse than the measurement of plasma insulin concentrations. However, these models can be modified in such a way that it can be used with measurements of plasma insulin concentrations.

[Toffolo 1995] introduces a c-peptide minimal model for an IVGTT which was extended by Breda to an oral c-peptide minimal model [Breda 2001]. The model assumes that  $\beta$ -cell insulin secretion depends on glucose plasma concentrations (static component, delayed production of new insulin) and on the rate of change of glucose plasma (dynamic component, secretion of stored insulin). This model is comparable with Toffolo's model in 1980 that use the same static component, the same order ( $1^{st}$ ) for clearance of insulin, but with no static delay and no dynamic component. The introduction of a dynamic component into the model of  $\beta$ -cell insulin secretion gives the model more physiological meaning. The model is shown in (b4, b5) where  $SR_s(t)$  [pM/min] is the static  $\beta$ -cell insulin response,  $SR_d(t)$  [pM] is the dynamic  $\beta$ -cell insulin response and  $1/\alpha$  [min] is the delay time in the static response.

$$SR(t) = SR_s(t) + SR_d(t)$$

$$\dot{SR}_s(t) = \alpha \{ SR_s(t) - y \cdot [G(t) - h] \} \quad SR_s(0) = 0 \quad (b5)$$

$$SR_d(t) = \begin{cases} K_D \cdot \dot{G}(t) & \text{if } G(t) > 0 \\ 0 & \text{if } G(t) \leq 0 \end{cases}$$

[Breda 2002] test reveals that impaired glucose tolerance humans have a diminished  $S_I$ , but an unaltered static and dynamic component as Bergman [Bergman 1981] found in *obese* lower tolerance humans. This test also reveals a delay between  $\beta$ -cell insulin secretion and changes of glucose concentration in plasma. Several other papers show similar results, e.g. [Ehrmann 2002, Cretti 2001]. Other publications have been published having likewise models [Mari 2002].

Both Steil's model and Breda's model are compared in [Steil 2003] using Bergman's minimal model [Bergman 1979] during a CLAMP on healthy humans. Both models fit the  $\beta$ -cell insulin secretion profile with low residuals. Also, comparable parameters between both models are not statistical different. However, Steil's model has better performance than Breda's model, since Steil's model has parameters with lower variations, more stability in close loop systems and adjusts better insulin needs to varying  $S_I$  and endogenous glucose appearance. One drawback is that Steil's model is tested by a CLAMP and not during physiological circumstances like Breda's model that is tested during an OGTT. Since Steil's model represents very well the  $\beta$ -cell insulin secretion behaviour and has interesting closed loop properties for future application of the model into an automated portable continuous glucose monitoring system, this model is used.

### C.1 Insulin profiles

(min)	profile 1 <sup>1</sup>		Profile 2 <sup>2</sup>	
	I(t) [pM]	G(t) [mM]	I(t) [pM]	G(t) [mM]
-15	53.0	6.16	55.1	6.16
1	45.9	6.55	53.7	5.12
15	86.2	6.66	94.6	7.59
30	134	7.87	139	10.0
45	145	8.31	143	11.2
60	165	8.91	152	13.5
90	174	8.97	209	14.6
120	169	9.52	194	14.4
180	196	8.86	133	9.52
240	162	8.91	100	4.18

Table c.1: Two insulin and glucose profiles [Wagenmakers 2006] measured during an OGTT (75 gram glucose)

### C.2 Samples Schedules

(min)	Sample schedules																																	
1	0	1	2	3	4	5	6	7	8	9	10	...	240																					
2	0	10	20	25	30	35	40	45	50	55	60	65	70	80	90	120	180	240																
3	0	15	30	45	60	90	120	180	240																									

Table c.2: Sample schedule 1, 2 and 3

### C.3 Datasets

Dataset 1 is generated using insulin profile 1 and sample schedule 1.  
 Dataset 2 is generated using insulin profile 2 and sample schedule 1.  
 Dataset 3 is generated using insulin profile 1 and sample schedule 2.  
 Dataset 4 is generated using insulin profile 2 and sample schedule 2.  
 Dataset 5 is generated using insulin profile 1 and sample schedule 3.  
 Dataset 6 is generated using insulin profile 2 and sample schedule 3.

Interstitial glucose  $\overline{G'(t)}$  is measured in all previous datasets by taking the mean over each 30 minutes by taking the first sample at the 30<sup>th</sup> minute and the last sample at 240<sup>th</sup> minute.

<sup>1</sup> Subject no: 5 Visit 6 / Day 15 [Wagenmakers 2006]

<sup>2</sup> Subject no: 8 Visit 6 / Day 15 [Wagenmakers 2006]

<sup>3</sup> Conversion factor between [ $\mu\text{U} / \text{l}$ ] to [pM]: 7.0625.

<sup>4</sup> Conversion factor between [mg/dl] to [mM]: 1/180.16 1/mM

### C.4 Simulated model

## Insulin profile 1

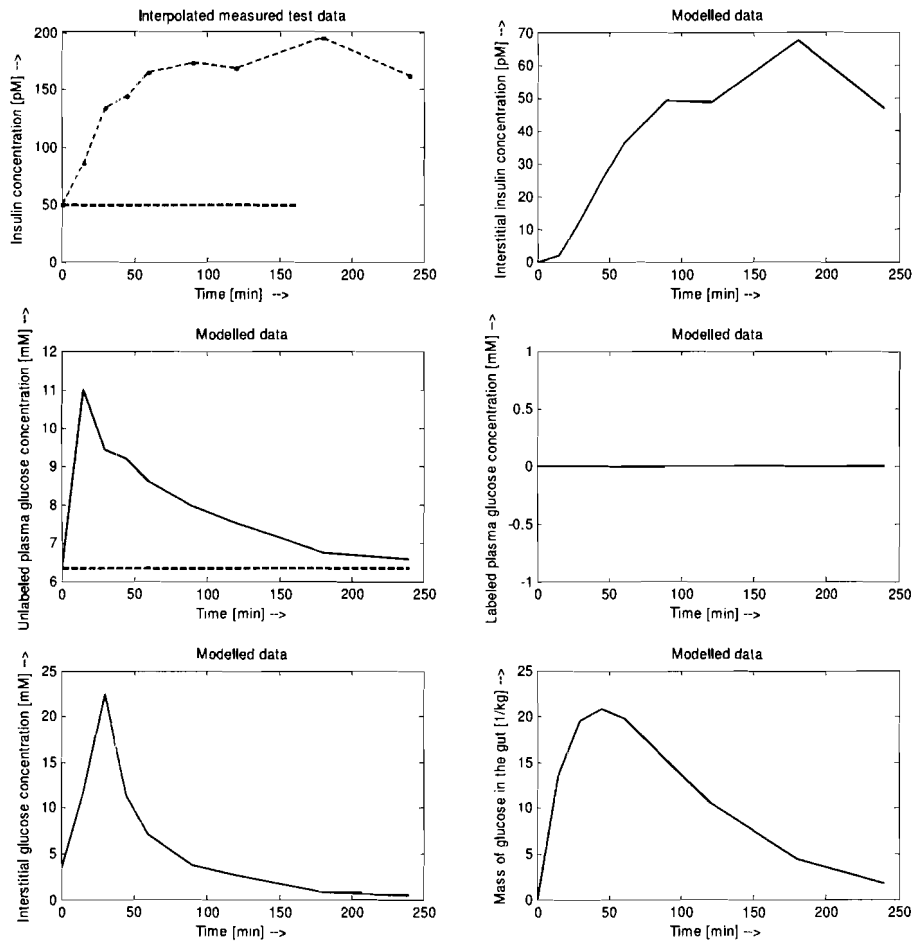

Figure c.1: Simulated glucose plasma, insulin plasma, interstitial glucose, interstitial insulin and the rate of appearance using profile 1, sample schedule 1 and true value shown in table 1



## Insulin profile 2

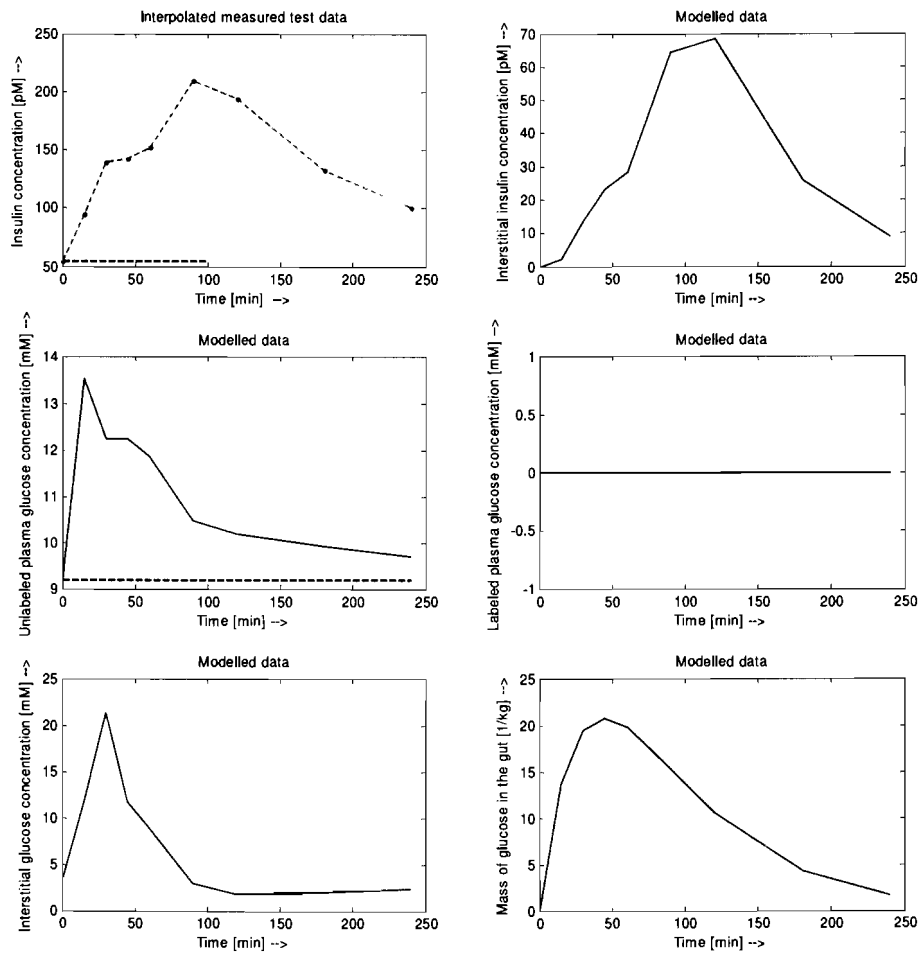
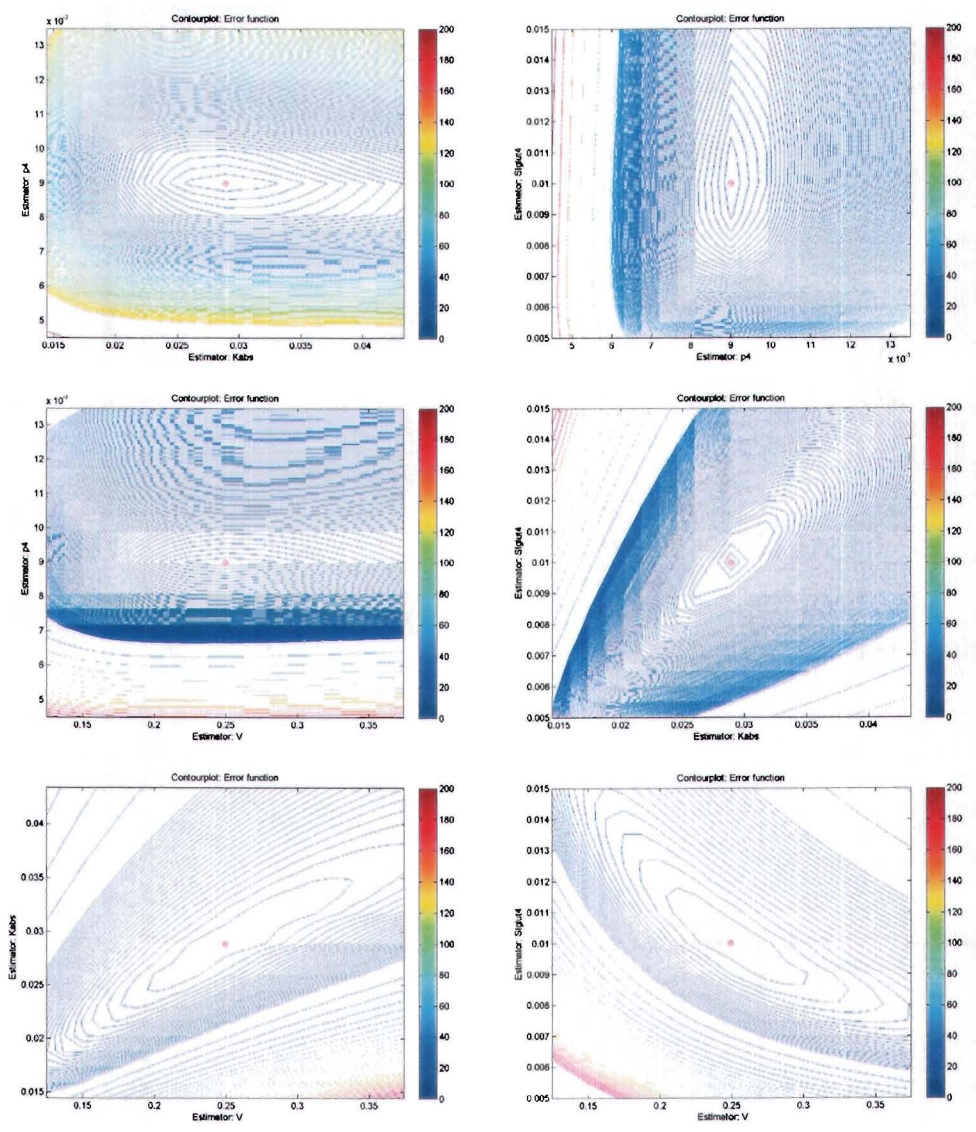
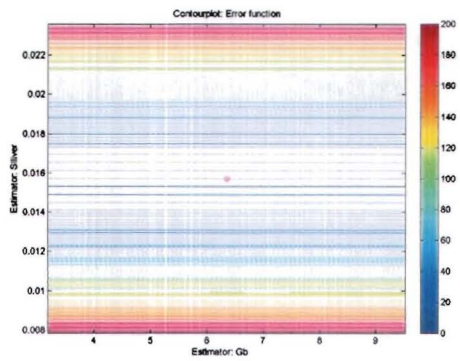
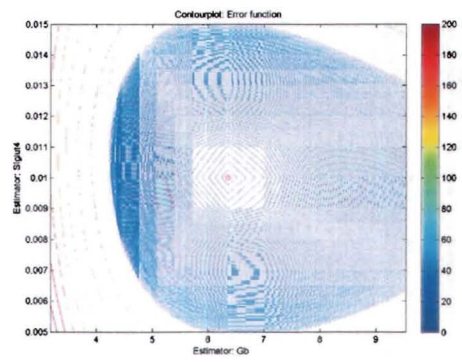
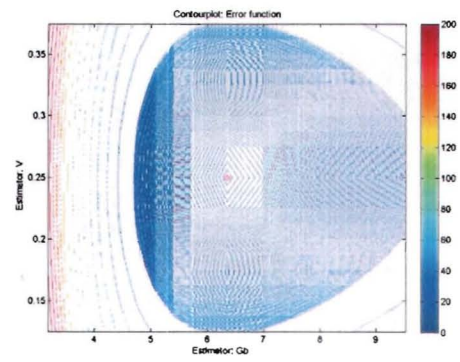
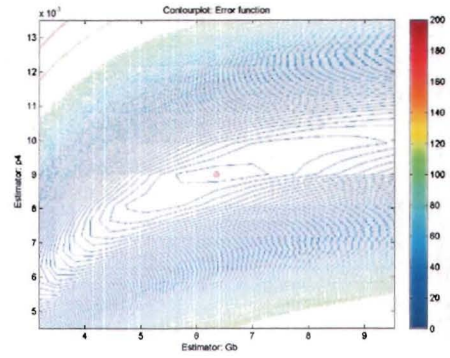
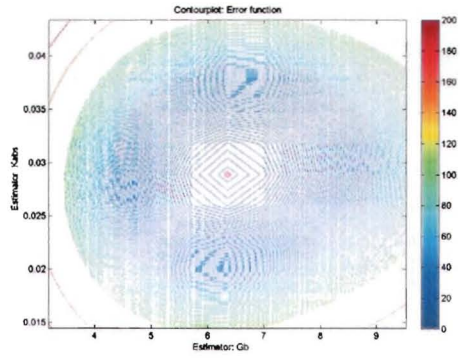

Figure c.2: Simulated glucose plasma, insulin plasma, interstitial glucose, interstitial insulin and the rate of appearance using profile 1, sample schedule 2 and true value shown in table 1

# Plots of model to model adjustment

## Model 1





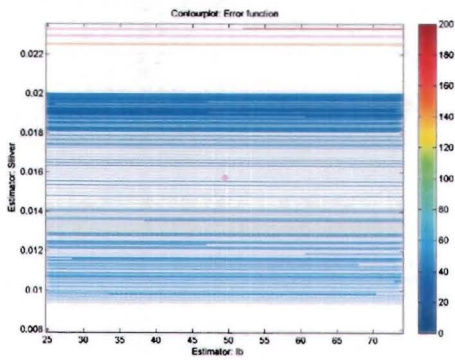
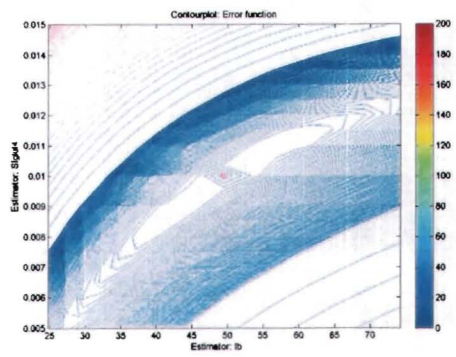
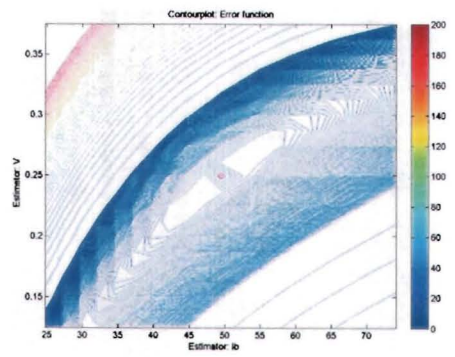
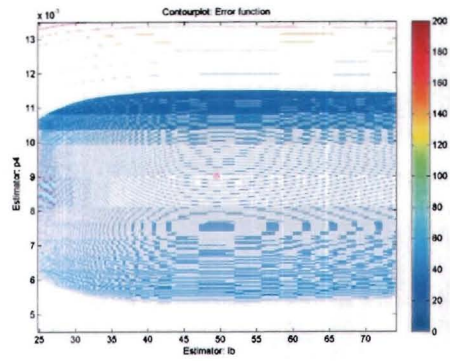
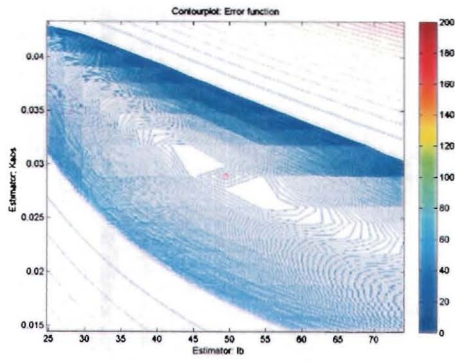

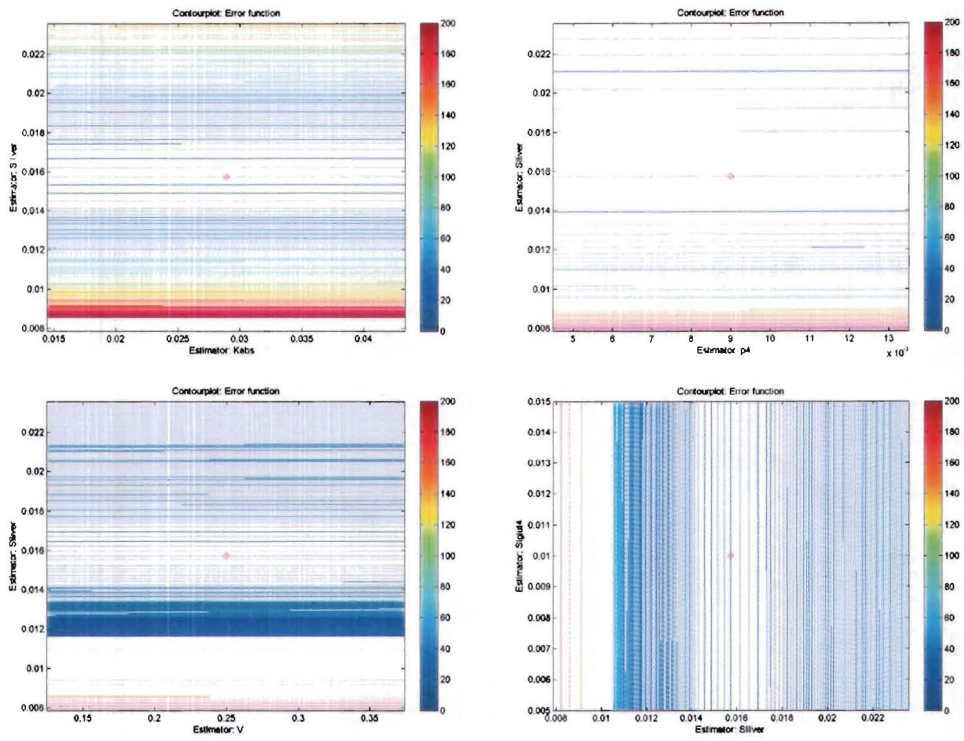
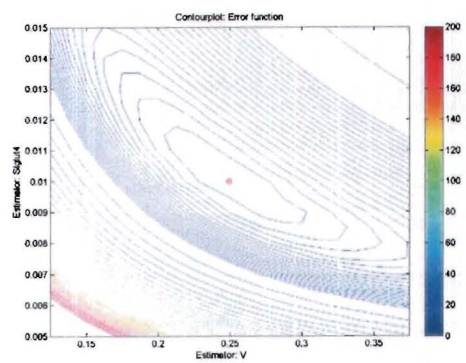
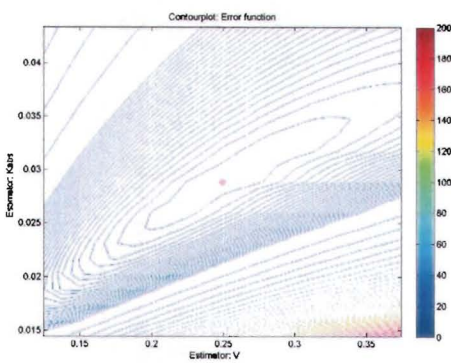
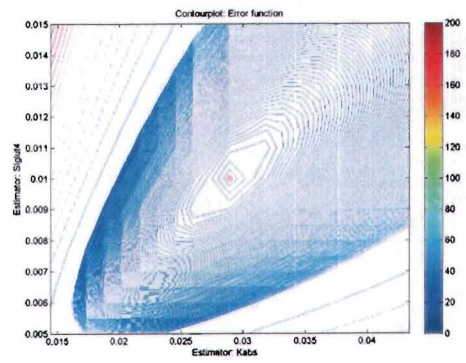
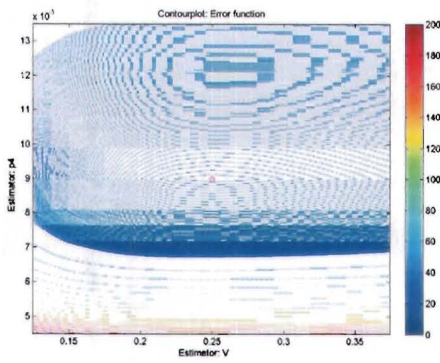
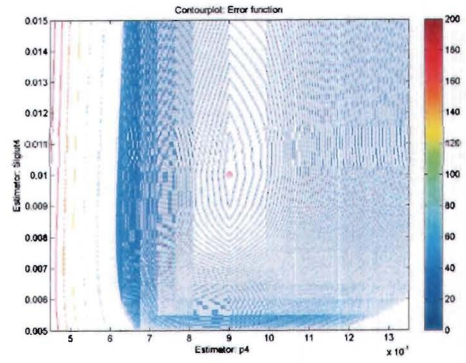
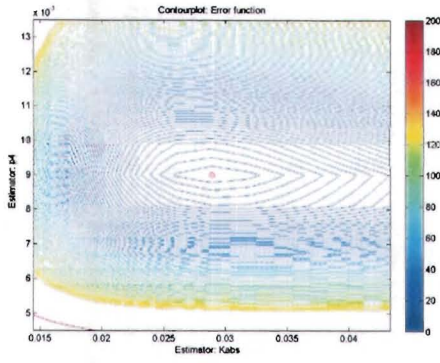
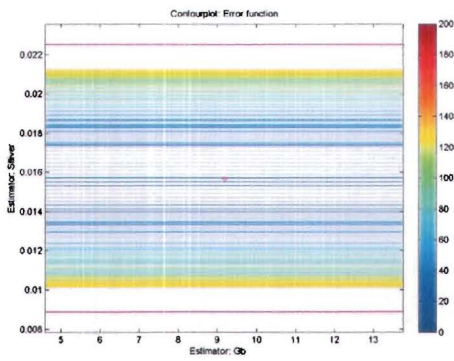
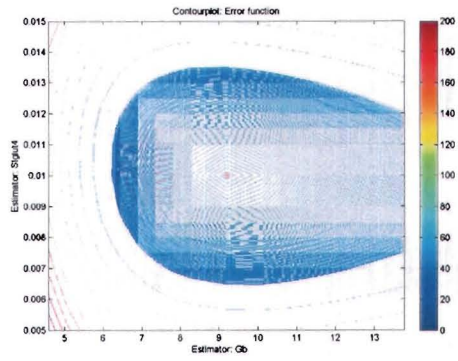
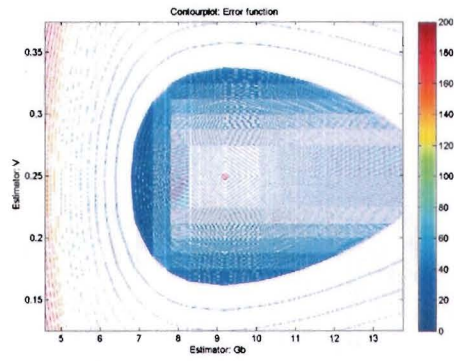
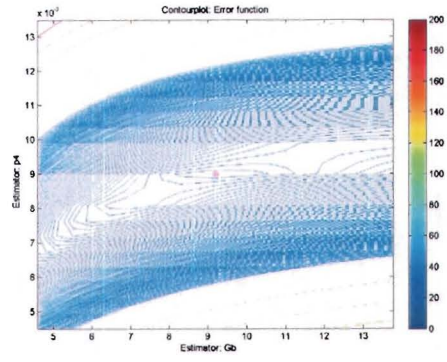
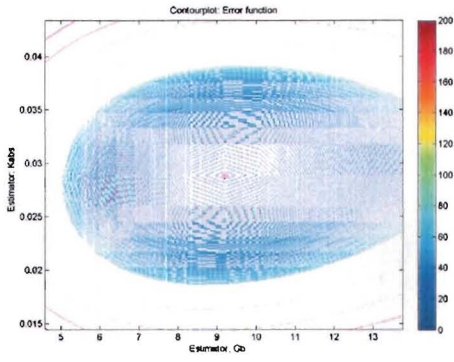

Figure D.1: Plots of model to model adjustment of model 1 using dataset 1 (appendix c) with no added white noise





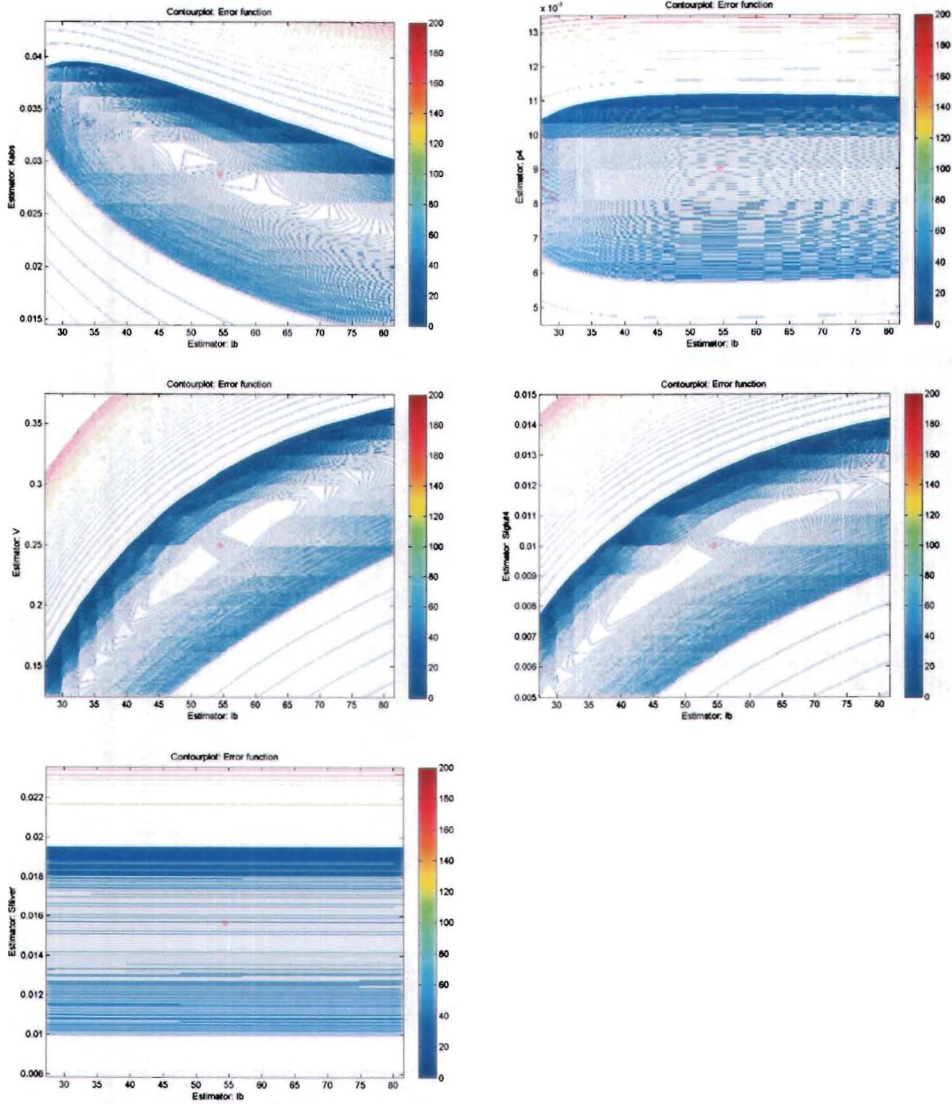

Figure D.2: Plots of model to model adjustment of model 1 using dataset 2 (appendix c) with no added white noise



## Model 2

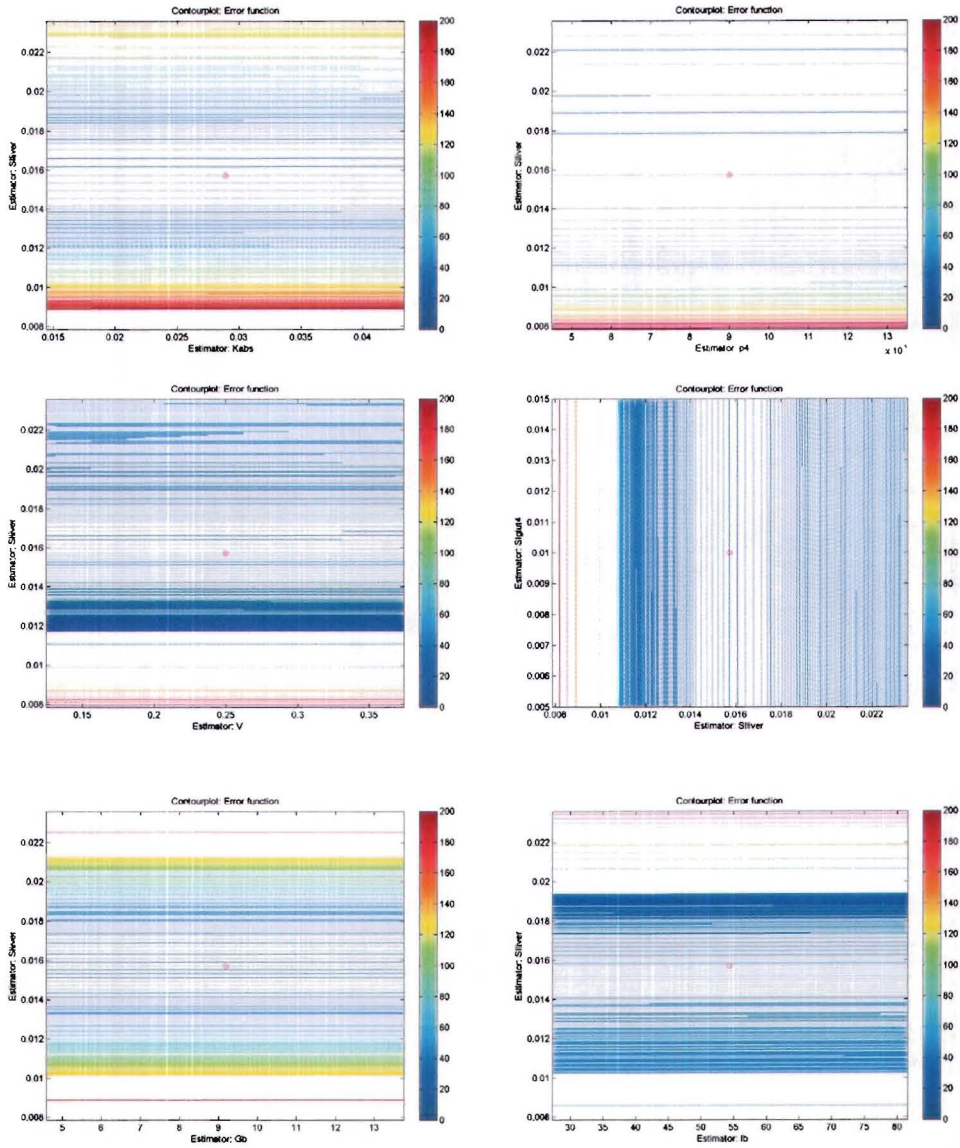
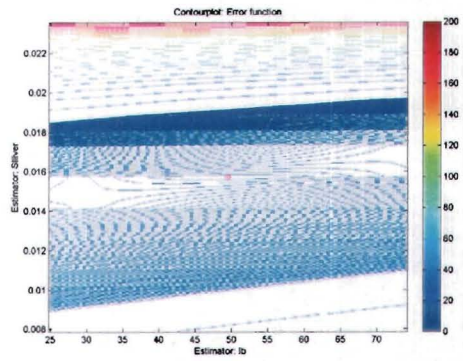
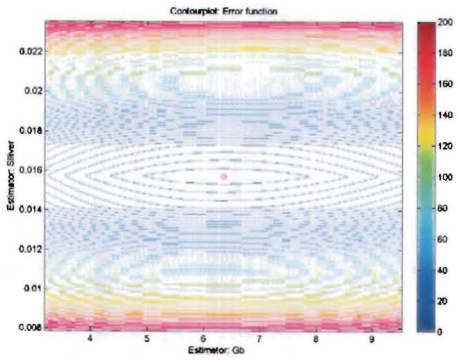
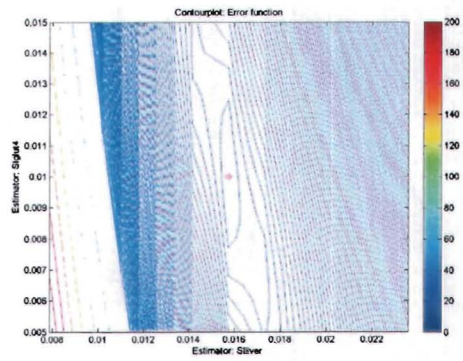
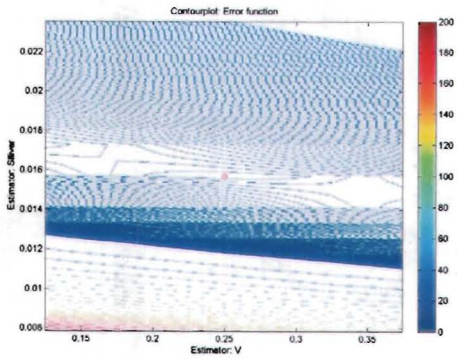
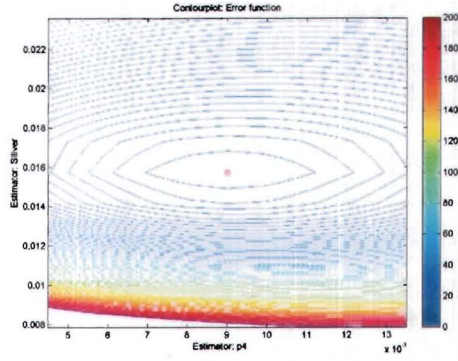
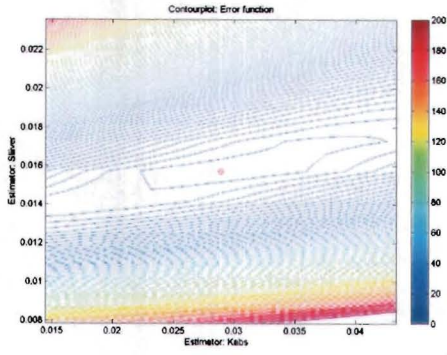
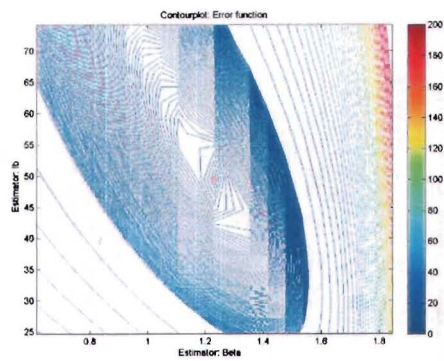
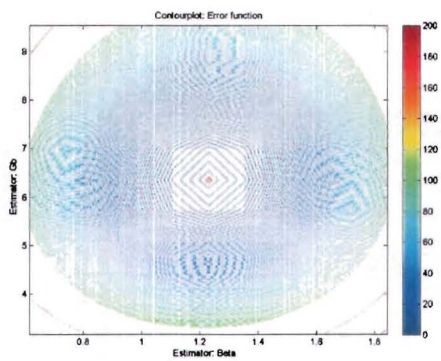
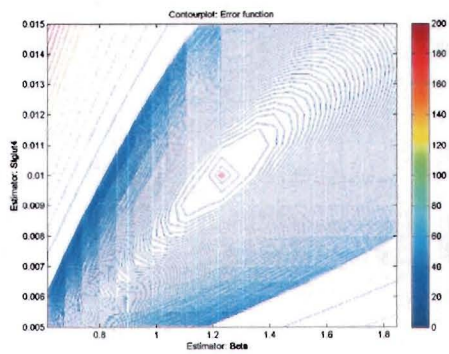
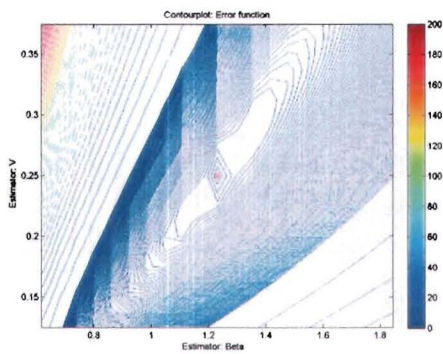
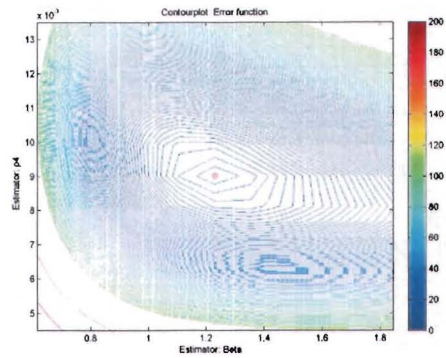
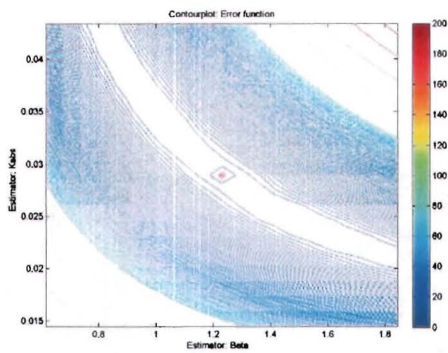

Figure D.3: Plots of model to model adjustment of model 2 using dataset 2 (appendix C) with no added white noise

### Model 3





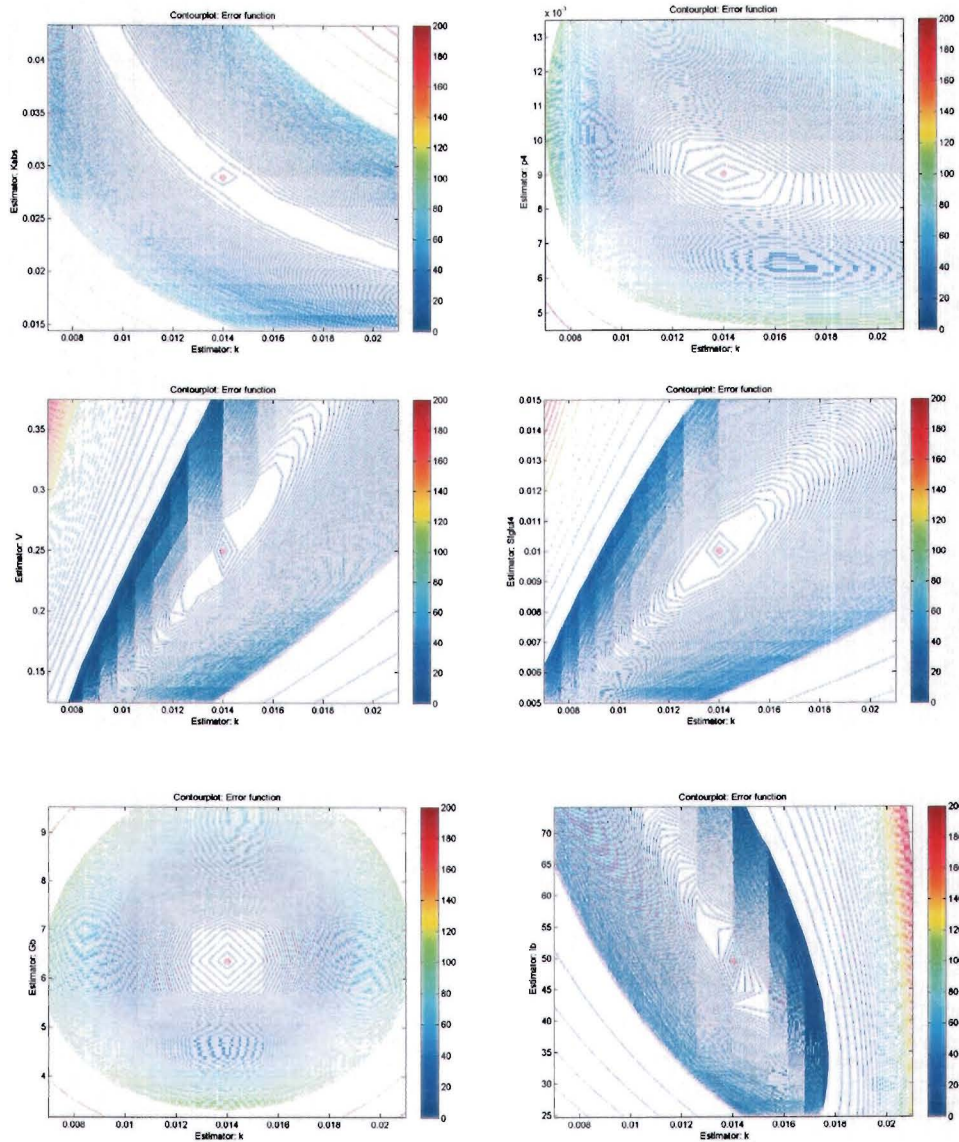

Figure D.4: Plots of model to model asjtuement of model 3 using dataset 3 (appendix C) with no added white noise

A priori parameter sensitivity for kabs

I/SNR (%)	profile 1				profile 2			
	Ib	Gb	beta	k	Ib	Gb	beta	k
0	40.0	72.5	99.4	103.7	31.4	59.1	145.0	143.3
5	40.0	40.0	131.7	130.7	17.2	58.9	184.0	166.9
10	40.0	73.3	153.5	168.6	17.4	59.0	241.3	195.1

I/SNR (%)	profile 1				profile 2			
	p2	p5	S <sub>G</sub>	Si-liver	p2	p5	S <sub>G</sub>	Si-liver
0	12.7	0.829	0.720	1.10	2.39	0.818	1.40	1.18
5	5.36	0.657	0.381	3.03	9.44	3.04	0.0242	2.00
10	3.86	3.33	2.42	4.46	9.93	1.60	1.38	91.6

A priori parameter sensitivity for v

I/SNR (%)	profile 1				profile 2			
	Ib	Gb	beta	k	Ib	Gb	beta	k
0	40.0	70.6	12.2	10.3	28.6	59.6	8.24	8.33
5	49.0	84.6	19.1	16.9	9.5	63.2	105.1	80.2
10	43.1	94.2	43.1	51.6	27.6	68.0	74.2	72.9

I/SNR (%)	profile 1				profile 2			
	p2	p5	S <sub>G</sub>	Si-liver	p2	p5	S <sub>G</sub>	Si-liver
0	6.12	1.00	0.903	0.328	1.81	1.36	2.19	1.16
5	20.3	3.21	3.29	4.42	9.47	20.8	2.11	10.4
10	4.27	8.3	5.36	5.39	66.6	10.1	7.22	13.9

A priori parameter sensitivity for p4

I/SNR (%)	profile 1				profile 2			
	Ib	Gb	Beta	k	Ib	Gb	beta	k
0	50.0	50.0	7.55	10.0	22.48	49.8	17.0	15.9
5	40.0	394.7	25.4	23.5	20.8	60.0	53.2	46.7
10	40.0	63.0	39.0	41.9	56.7	307.6	52.63	157.2

I/SNR (%)	profile 1				profile 2			
	p2	p5	S <sub>G</sub>	Si-liver	p2	p5	S <sub>G</sub>	Si-liver
0	2.13	0.789	0.111	0.180	3.08	0.893	1.21	1.19
5	6.89	3.32	2.53	3.84	6.96	2.58	1.49	10.86
10	4.35	8.78	3.10	8.77	108.4	8.63	5.84	60.86

A priori parameter sensitivity for Si-Glut4

I/SNR (%)	profile 1				profile 2			
	Ib	Gb	beta	k	Ib	Gb	beta	k
0	50.0	50.0	11.2	13.9	42.9	47.6	21.6	19.8
5	48.2	946.4	38.4	29.1	41.8	234.4	53.6	44.9
10	48.7	770.4	52.4	48.1	56.7	307.6	52.63	157.2

I/SNR (%)	profile 1				profile 2			
	p2	p5	S <sub>G</sub>	Si-liver	p2	p5	S <sub>G</sub>	Si-liver
0	34.0	0.135	0.771	0.625	36.0	0.262	1.61	0.831
5	40.7	3.98	2.30	4.04	39.7	20.2	1.76	14.0
10	42.58	15.6	6.56	7.00	66.6	10.1	7.22	13.9

Table E.1: A priori parameter sensitivity for  $k_{abs}$ ,  $v$ ,  $p_4$  and  $Si\text{-}glut_4$  using synthetic data and using two different insulin profiles (data sets 1, 2, respectively, appendix c) with added white noise having a I/SNR of 0, 5 and 10%

**European Research activities**  
**On**  
**(Closed loop) artificial pancreas and automatic insulin delivery**

**Consulted sources:**

EMBase (ScienceDirect), MEDLINE (ScienceDirect), Elsevier BIOBASE (ScienceDirect), Pubmed, Pascal (Pica), Web of Science, Elsevier Scopus, Inspec (webspurs)

**Diabetes Modelling Group, Department of Paediatrics, Univ. Cambridge, Box 116, A.**

**Principal Author(s):** Hovorka, R. Chassin, L.J.

**Literature:**

Chassin, L.J.<sup>a</sup>, M.E. Wilinska<sup>a</sup> and R. Hovorka<sup>a,f</sup>, "Grading system to assess clinical performance of closed-loop glucose control," *Diabetes Technology and Therapeutics*, Vol. 7 (2005), No. 1, p. 72-82.

Hovorka, R., "Management of diabetes using adaptive control", *International Journal of Adaptive Control and Signal Processing*, Vol 19(2005), No. 5, p. 309-325.

Chassin, L.J., M.E. Wilinska and R. Hovorka, "Evaluation of glucose controllers in virtual environment: Methodology and sample application," *Artificial Intelligence in Medicine*, Vol. 32(2004), No. 3, p. 171-181.

Hovorka, R.<sup>a,f</sup>, L.J. Chassin<sup>a</sup>, M.E. Wilinska<sup>a</sup>, V. Canonico<sup>b</sup>, J.A. Akwi<sup>b</sup>, M.O. Federici<sup>b</sup>, M. Massi-Benedetti<sup>b</sup>, I. Hutzli<sup>c</sup>, C. Zaugg<sup>c</sup>, H. Kaufmann<sup>c</sup>, M. Both<sup>c</sup>, T. Vering<sup>c</sup>, H.C. Schaller<sup>d,e</sup>, L. Schaupp<sup>d</sup>, M. Bodenlenz<sup>d,e</sup> and T.R. Pieber<sup>d</sup>, "Closing the loop: The adicol experience," *Diabetes Technology and Therapeutics*, Vol. 6(2004), No. 3, p. 307-318.

<sup>a</sup> Diabetes Modelling Group, Department of Paediatrics, University of Cambridge, Cambridge, United Kingdom

<sup>b</sup> Department of Medicine, University of Perugia, Perugia, Italy

<sup>c</sup> Disetronic Medical Systems AG, Burgdorf, Switzerland

<sup>d</sup> Dept. of Int. Med., Diabet./Metab., Medical University of Graz, Graz, Austria

<sup>e</sup> Department of Biophysics, Institute of Biomedical Engineering, University of Technology Graz, Graz, Austria

<sup>f</sup> Diabetes Modelling Group, Department of Paediatrics, University of Cambridge, Hills Road, Cambridge CB2 2QQ, United Kingdom

**Website:** <http://www.iph.cam.ac.uk/diabetes/>

.....  
**Inst. für Diabetes-Technologie, Universität Ulm, Helmholtzstr. 20, D-89081 Ulm, Germany:**

**Principal Author(s):** Freckmann, G. B.

**Literature:**

Jendrike N, H. Buck, A. Abicht, C. Haug and G. Freckmann G, "Hypoglycemia Detection With Two Different Continuous Glucose Monitoring Systems", *Diabetologica*, Vol. 47(2004) (Suppl 1), pA324.

Freckmann, G. B. Kalatz, B. Pfeiffer, U. Hoss and C. Haug, "Recent advances in continuous glucose monitoring," *Experimental and Clinical Endocrinology and Diabetes*, Vol. 109(2001), Suppl. 2, p. S347-S357.

Kerner, W. H. Moll, I. Navascues and E.F. Pfeiffer, "Importance of early postprandial insulin delivery in insulin-dependent diabetics," *Klin. Wochenschr.*, Vol. 62(1984), No. 15, p. 738-744.

More publications available at <http://www.idt-ulm.de/frame1.htm>



Website: <http://www.idt-ulm.de/frame1.htm>

.....

INSERM U.341. Service de Diabetologie. Hotel-Dieu, 1, Place du Parvis Notre Dame, F 75004 Paris, France (Unite de Recherches sur le Diabete et la Nutrition chez l'Enfant, INSERM U83, 75010 Paris, France)

Principal Author(s): Reach G.

**Literature:**

Choleau, C. and G. Reach, "Continuous glucose monitoring: Different systems, different ambitions," *Diabetes and Metabolism*, Vol. 29(2003), No. 2 II.

Choleau, C., P. Dokladal, J.-C. Klein, W.K. Ward, G.S. Wilson, and G. Reach, "Prevention of hypoglycemia using risk assessment with a continuous glucose monitoring system," *Diabetes*, Vol. 51(2002), No. II, p. 3263-3273.

Reach G., "Towards self-regulation closed-loop treatment for diabetes [Vers un traitement du diabete autoregule en Boucle fermee]," *Annales d'Endocrinologie*, Vol. 56(1995), No. 1, p. 43-48.

Reach G., and Y.M. Yaffrin, "Kinetic modelling as a tool for the design of a vascular bioartificial pancreas: Feedback between modelling and experimental validation," *Comput. Methods Programs Biomed.*, Vol. 32(1990), No. 3-4, p. 277-285.

Lepeintre J., H. Briandet, F. Moussy, D. Chicheportiche, S. Darquy, J. Rouchette, P. Imbaud, J.J. Duron and G. Reach, "Ex vivo evaluation in normal dogs of insulin released by a bioartificial pancreas containing isolated rat islets of Langerhans," *Artif. Organs*, Vol. 14(1990), No. 1, p. 20-27.

Velho G., P.H. Froguel and G. Reach, "Determination of peritoneal glucose kinetics in rats: implications for the peritoneal implantation of closed-loop insulin delivery systems," *Diabetologia*, Vol. 32(1989), No. 6, p. 331-336.

Reach G., M.Y. Jaffrin and J.F. Desjeux, "A U-shaped bioartificial pancreas with rapid glucose-insulin kinetics. In vitro evaluation and kinetic modeling," *Diabetes*, Vol. 33(1984), No. 8, p. 752-761.

Reach G., P. Poussier, A. Sausse, R. Assan, M. Itoh and J.E. Gerich, "Functional evaluation of a bioartificial pancreas using isolated islets perfused with blood ultrafiltrate," *Diabetes*, Vol. 30(1981), No.4, p. 296-301. (Endocrine Res. Unit, Mayo Clin., Rochester, MN 55901, USA)

Website: <http://diabete.hotel-dieu.com>

.....

Svc. d'Endocrinologie Diabetologie. Hop. Universitaires de Strasbourg. Hopital Civil, 1 place de l'Hopital, 67091 Strasbourg Cedex, France.

Principal Author(s): Kessler, L.

**Literature:**

Laurence K., S. Tritschler, A. Bohbot, S. Sigrist, V. Karsten, S. Boivin, P. Dufour, A. Belcourt and M. Pinget, "Macrophage Activation in Type 1 Diabetic Patients With Catheter Obstruction During Peritoneal Insulin Delivery With an Implantable Pump," *Diabetes Care*, Vol. 24(2001), p. 302-307.

Kessler, L. <sup>a i</sup>, R. Passemard <sup>a</sup>, J. Oberholzer <sup>b</sup>, P.Y. Benhamou <sup>c</sup>, P. Bucher <sup>b</sup>, C. Toso <sup>b</sup>, P. Meyer <sup>d</sup>, A. Penfornis <sup>e</sup>, L. Badet <sup>f</sup>, P. Wolf <sup>g</sup>, C. Colin <sup>h</sup>, P. Morel <sup>b</sup> and M. Pinget <sup>a</sup>, "Reduction of blood glucose variability in type 1 diabetic patients treated by pancreatic islet transplantation: Interest of continuous glucose monitoring," *Diabetes Care*, Vol. 25(2002), No. 12, p. 2256-2262.

Kessler L. and M. Pinget, "From insulin pump to artificial pancreas: An autoregulated treatment for diabetes," *Revue Francaise d'Endocrinologie Clinique - Nutrition et Metabolisme*, Vol. 40(1999), No. 3-5, p. 275-296.

**Website:** <http://www-ulpmed.u-strasbg.fr/>

<sup>a</sup> Department of Endocrinology, University Hospital, Strasbourg, France

<sup>b</sup> Department of Surgery, University Hospital, Geneva, Switzerland

<sup>c</sup> Department of Endocrinology, University Hospital, Grenoble, France

<sup>d</sup> Department of Medical Information, University Hospital, Strasbourg, France

<sup>e</sup> Department of Endocrinology, University Hospital, Besancon, France

<sup>f</sup> Department of Urology, Hospices Civils, Lyon, France

<sup>g</sup> Department of Transplantation, University Hospital, Strasbourg, France

<sup>h</sup> Department of Medical Information, Hospices Civils, Lyon, France

<sup>i</sup> Service d'Endocrinologie et de Diab tologie, H pitaux Universitaires, 1, Place de l'H pital, 67091 Strasbourg Cedex, France

.....  
**Department of Endocrinology, Lapeyronie Hospital, F34295 Montpellier Cedex 5, France**

**Principal Author(s):** Renard, E.

**Literature:**

Renard, E., Implantable glucose sensors for diabetes monitoring, *Minimally Invasive Therapy and Allied Technologie*, Vol. 13(2004), No. 2, p. 78-86.

Renard, E., "Insulin therapy by insulin pump: Continuous or conventional self-blood glucose monitoring?," *Diabetes and Metabolism*, Vol. 29(2003), No. 2 II.

Renard, E., "Implantable closed-loop glucose-sensing and insulin delivery: The future for insulin pump therapy," *Current Opinion in Pharmacology*, Vol 2.(2002), No.6, p. 708-716.

**Website:** [http://irb.chu-montpellier.fr/fr/equipes\\_diabete.html](http://irb.chu-montpellier.fr/fr/equipes_diabete.html),  
(<http://www.chu-montpellier.fr/GB/techcliniq/act-mal-endocrino.html?id=61&LANG=GB>)

.....  
**Istituto per Ricerche di Dinamica dei Sistemi e di Bioingegneria, Consiglio Nazionale delle Ricerche, Univ. Padova, 35100 Padova, Italy**

**Principal Author(s):** Cobelli C.;

**Literature:**

(no newer literature found)

Cobelli C., and A. Ruggeri, "Evaluation of portal/peripheral route and of algorithms for insulin delivery in the closed-loop control of glucose in diabetes: A modelling study", *IEEE Trans. BIO-MED. Eng.*, Vol. 30(1983), No. 2, p. 93-103.

Cobelli, C., G. Pacini, A. Ruggeri, S. Del-Prato, E. Duner, R. Nosadini and A. Tiengo, "Algorithms for closed-loop glucose control (artificial pancreas) in diabetes. A novel noninvasive approach for their evaluation based on mathematical modelling", Control Science and Technology for the Progress of Society Proceedings of the Eighth Triennial World Congress of the International Federation of Automatic Control, *Pergamon*, Vol. 7 (1982), p. 3711-3716.

Nosadini R., G.A. Noy, M. Natrass M., K.G. Alberti, D.G. Johnston, P.D. Home and H. Orskov, "The metabolic and hormonal response to acute normoglycaemia in type 1 (insulin-dependent) diabetes: Studies with a glucose controlled insulin infusion system (artificial endocrine pancreas)", *Diabetologia*, Vol. 23(1982), No. 3, p. 220-228. (Dep. Gerontol. Mal. Ricamb. Policlin. Univ., Padova, Italy)

**Website:** <http://www.dei.unipd.it/wdyn/?IDsezione=372>,  
[http://www.dei.unipd.it/wdyn/?IDsezione=3313&IDgruppo\\_pass=32&preview](http://www.dei.unipd.it/wdyn/?IDsezione=3313&IDgruppo_pass=32&preview)

.....  
**Istituto di Patologia Speciale Medica, University of Perugia, Via E. dal Pozzo, 06100 Perugia, Italy**  
(Internal Medicine and Endocrine and Metabolic Sciences)

**Principal Author(s):** Reboldi G.P

**Literature:**

Reboldi G.P., P.D. Home, G. Calabrese, P.G. Fabietti, P. Brunetti P. and M. Massi Benedetti, "Time delay compensation for closed-loop insulin delivery systems: A simulation study," *Int. J. Artif. Organs*, Vol. 14(1991), No. 6, p. 350-358.

**Website:** <http://bioingweb.dimisem.med.unipg.it/default.htm>,  
<http://bioingweb.dimisem.med.unipg.it/scuole/endocrinologia/Default.htm>

.....

OLDER LITERATURE

.....  
Diabetic Hospital Steno Diabetes Center, Gentofte, Denmark

Principal Author(s):

Literature:

Deckert T., J. Bojsen, J.S. Christiansen, K. Kolendorf, P.A. Svendsen and A.R. Andersen., "24-Hour blood glucose profiles in insulin-dependent diabetics treated with intravenous insulin infusion systems. A comparison between closed- and open-loop systems," *Acta Med. Scand.*, Vol. 208(1980), No. 6, p. 451-458.

.....  
Metab. Unit, City Hosp. Vienna-Lainz, Vienna, Austria

Principal Author(s): Irsigler K.; Kritz H.

Literature:

Irsigler K. and H. Kritz, "Alternate routes of insulin delivery," *Diabetes Care*, Vol. 3, No. 2 (1980), p. 219-228.

.....  
Cent. Morphol. Mathemat., Ec. Mines Paris, 77305 Fontainebleau, France

Principal Author(s): Klein, J C; Slama, G,

Literature:

Klein, J. C. and G. Slama, "A sophisticated programmable miniaturised pump for insulin delivery," *Medical Progress Through Technology*, Vol. 7, No. 4, p 193-197.

.....  
Vuk Vrhovac Institute for Diabetes, Endocrinology and Metabolic Diseases, School of Medicine, University of Zagreb, YU-41000 Zagreb, Yugoslavia

Principal Author(s): Ravnik-Oblak, M., Granic, M.

Literature:

Ravnik-Oblak, M., and M. Granic, "Closed-loop systems in the management of diabetes," *Diabetologia Croatica*, Vol. 17(1988), No.2 , p ?.

**Med. Klin. Isar. Tech. Univ. Munchen, Germany**

**Principal Author(s):** Bottermann, P., Gyaram, H., Wahl, K., et al

**Literature:**

Bottermann, P., H. Gyaram, K.Wahl , R. Ermler and A. Lebender, "Pharmacokinetics of biosynthetic human insulin and characteristics of its effect", *Diabetes Care*, Vol. 4(1981), No. 2, p. 168-169.



**Clin. Mal. Metab. Endocriniennes, Hop. Saint Eloi, Montpellier, France**

**Principal Author(s):**Mirouze, J., Selam, J.L., Chi Pham, T.

**Literature:**

Mirouze, J., J.L. Selam and T. Chi Pham, "Servo-controlled versus continuous insulin infusion as a factor of remission in juvenile diabetes," *ASAIIO Journal*, Vol. 3(1980), No. 4, p. 133-139.



## Matlab code

### D.I Basic files

#### D.I.1

##### gluc\_param\_new.m

```
%  
%Oral Minimal Model of glucose kinetics.  
%  
%This script initialize all parameters of the Oral Minimal Model of  
%glucose  
%kinetics and the time samples of plasma insulin.  
%%  
%  
%History  
%22 March 06, Salvador Almeida-Ferreira, FIO  
%19 Jan 04, Natal van Kesteren, FIO  
%11 Jun 03, Natal van Kesteren, FIO  
%  
  
close all; clear all;  
make_plots = 0;  
plt=0;  
  
%Fixed model parameters:  
%Values from [1].  
  
if 1 % default values for patient 1  
Ib = 7.0625*(7.5+6.5)/2; % [mM] baseline insulin concentration in plasma  
Gb = 0.055*(112+119)/2; % [mM] baseline glucose concentration in plasma  
GIb=3.38; % [mM] baseline glucose concentration in interstitium  
end  
  
if 0 % Subject no: 1b - Mean values for patient 1  
Ib = 7.0625*(6.4+4.5)/2; % [mM] baseline insulin concentration in plasma  
Gb = 0.055*(112+93)/2; % [mM] baseline glucose concentration in plasma  
GIb=3.38; % [mM] baseline glucose concentration in interstitium  
end  
  
if 0 % Subject no: 8 - Mean values for patient 1  
Ib = 7.0625*(7.8 + 7.6)/2; % [mM] baseline insulin concentration in  
plasma  
Gb = 0.055*(165+169)/2; % [mM] baseline glucose concentration in plasma  
GIb=3.38; % [mM] baseline glucose concentration in interstitium  
end  
  
%Known/unknown model parameters  
% (Mean) values obtained from nine type 1 diabetic patient [1]
```

```

%
%Annual International Conference on the IEFEE Future of the Bioscience
and
%Bioinformatics, Mexico, February 2005,
%Natafocyt, S., et al. In: Natta, G., ed. 2005, Marzi, E.,
Morosini,
sk. Bioinformatics,
%“Application of the Laplace transform to the ‘distance test,’”
%Proceedings of the 2005 Annual International Conference of the
%IEFEE Future of the Bioscience and Bioinformatics,
%vol. 1 (2005), pp. 272-273.
%
k8 =3e-2; % [1/pM] the efficacy of insulin to stimulate
%glucose transport from blood to interstitial space by recruitment
p2 = 0.113; % [1/min] rate constant for insulin destruction in insulin
%space
DS =75/10; % [10, 1/p] parameter for insulin recruitment scaled by
factor
%1/10
Kabs =2.89e-2; % [1/min] rate constant for insulin absorption from the
%intestine to blood
Beta = 1.23; % [1/min] the rate of insulin degradation in the slow
%insulin compartment, lowered by a factor of 10 in the fast
%compartment
k = 0.014; % [1/min] rate constant for insulin employment
V= 2.497e-1; % [l/min] volume of the slow insulin compartment of
%body
%weight
%[1.386e-1] in a 70 kg person
p5 =0.018; % [1/min] rate constant for insulin recruitment from blood
%to pancreas
p6 = 0.00763*10; % [1/min] rate constant for insulin recruitment to muscle
%scaled
%by factor 10
k7 = 0.063*(1/0.21); % [1/min] rate constant for insulin degradation in the
%compartment
SICap = 2e-3*0.0395*(1/0.21)*1e3; % [1/min] the efficacy of insulin to
%stimulate insulin transport from pancreas to interstitium by capillary
%recruitment scaled by factor 10
SIliver = 1.11e-5*1e4*(1/7.0625); % [1/min] the efficacy of
%insulin to
%inhibit hepatic production of glucose by liver,
%scaled by factor 1e4
SIglut4 = 1.0e-2; % [1/min] the efficacy of insulin to stimulate
%glucose
%clearance to muscle by recruitment of insulin
p4 = k7*k8; % [1/min] the rate constant of plasma glucose into
%interstitium
%scaled by factor 1
Coeff =3/75; % [1] coefficient for the amount of labeled glucose divided
%by the sum of labeled and unlabeled glucose
p_true = [Ib, Gb, p2, DS, Kabs, Beta, k, V, p4, p5, p6, SICap,...
SIliver, SIglut4,Coeff]; % [1] model model parameter space

```

```

%Fixed initial conditions
L0(1) = Gb; % [mM] glucose concentration in plasma
L0(2) = 0; % [mM] labeled glucose concentration in plasma
L0(3) = 0; % [pM] insulin concentration in interstitium
L0(4) = GIb; % [mM] glucose concentration in interstitium
L0(5) = 0; % [fM] glucose concentration in the gut

%input insulin concentration in plasma [pM]; assumed to be known at
each
%simulation time sample from linear interpolation of its measured
samples

%time and amplitude sample set for insulin
if 1 %Subject no: 5, Visit # = 1, Day 15
%1 - Blood glucose data
t_insulin1 = [0 15 30 45 60 90 120 180 240];
c_insulin1 = 7.0625*[(7.5+6.5)/2 12.2 19 20.5 23.3 24.6 23.9 27.7 23];
t_c_insulin1 = [t_insulin1' c_insulin1'];

%2 - interstitial glucose data
t_insulin2 = [0 15 30 45 60 90 120 180 240];
c_insulin2 = 7.0625*[(7.5+6.5)/2 12.2 19 20.5 23.3 24.6 23.9 27.7 23];
t_c_insulin2 = [t_insulin2' c_insulin2'];
end

if 0 %Subject no: 15, Visit # = 1, Day 15
%1 - Blood glucose data
t_insulin1 = [0 15 30 45 60 90 120 180 240];
c_insulin1 = 7.0625*[(6.4+4.5)/2 14.8 22.2 27 27.7 46.8 81 46 7.7];
t_c_insulin1 = [t_insulin1' c_insulin1'];

%2 - interstitial glucose data
t_insulin2 = [0 15 30 45 60 90 120 180 240];
c_insulin2 = 7.0625*[(6.4+4.5)/2 14.8 22.2 27 27.7 46.8 81 46 7.7];
t_c_insulin2 = [t_insulin2' c_insulin2'];
end

if 0 %Subject no: 9, Visit # = 1, Day 15
%1 - Blood glucose data
t_insulin1 = [0 15 30 45 60 90 120 180 240];
c_insulin1 = 7.0625*[(7.8 + 7.6)/2 13.4 19.7 20.2 21.5 29.6 27.5 18.8
14.2];
t_c_insulin1 = [t_insulin1' c_insulin1'];

%2 - interstitial glucose data
t_insulin2 = [0 15 30 45 60 90 120 180 240];
c_insulin2 = 7.0625*[(7.8 + 7.6)/2 13.4 19.7 20.2 21.5 29.6 27.5 18.8
14.2];
t_c_insulin2 = [t_insulin2' c_insulin2'];
end

% Squared 2 norm of the error time series residuals

```



```

a=1; %output weight factor of plasma glucose concentration (1st
output)
b=1; %output weight factor of total glucose concentration
%(2nd output)
c=1; %output weight factor of interstitial glucose concentration
%(3rd output)

sigma1=0.025; %variance of unexplained plasma glucose concentration(1st
output)
sigma2=0.05; %variance of interstitial glucose (2nd output)
sigma3=1;%0.06; %variance of total glucose concentration(3rd
output)

%Plots

% make plots if plt = 1
if plt==1;
%Plots
figure; plot(t_c_insulin(:,1), t_c_insulin(:,2), 'r'); hold
%Baseline level:
plot( [t_c_insulin(1,1) t_c_insulin(end,1)], [Ib Ib], '
n','r','LineWidth',1.5)
xlabel('Time (min)'); ylabel('Insulin concentration (mU/L)')
title('Insulin concentration')
end

% sample interval (min)
t_exp=15;

```

## D.1.2

### gluc\_ode\_new.m

```
function dLout = gluc_ode_new(t,Lin,t_c_insulin,p)

%
%GLUC_ODE: ODE's for the Minimal Model of Glucose Kinetics.
%
%This function solves GLUC_ODE_1M, a 5-d Minimal Model of Glucose
%kinetics using the parameters defined in the _param.m.
%%
%
%Function:
%dLout = gluc_ode_new(t,Lin,t_c_insulin,p)
%
%Inputs function:
%Lin: state values at previous time sample L(k-1) = [G(k-1);dGL(k-
%1);...
% X(k-1);Y(k-1); dGint(k-1); dGgut(k-1)]
% t_c_insulin: _insulin(k) (input signal at sample k) OR matrix
% t_c_insulin
% p: [Ib, Gb, p2, p3, kab, Bc1, k1, p4, p5, p6, S1cap,...
% S1inv, S1del, ...]; 3-15 dimensional parameter space
%
%Output function:
%dLout: new state derivatives dL(k) = [dG(k); dX(k); dY(k); dGgut(k)]
% column vector.
%%
%
%History
%22 March 06, Salvador Alman, Univ. of ...
%29 Jan 04, Natalya Riedl, Univ. ...
%17 Aug 03, Natalya Riedl, Univ. ...
%%
% defining the row were each state in state vector Lin is present
idG = 1; %glucose concentration [mM], first column of vector Lin
idGL = 2; %labeled glucose concentration [mM], second column of vector
Lin
idX = 3; %interstitial glucose concentration [mM], third column of vector
Lin
idY = 4; %interstitial glucose concentration[mM], fourth column of
vector Lin
idGgut = 5; %the part of glucose in the gut [1/kg], fifth column of
vector
Lin

% fixed model parameters:
Ib = p(1); %[mM] baseline insulin concentration in plasma
Gb = p(2); %[mM] baseline glucose concentration in plasma

% known/unknown model parameters
% glucose from blood plasma to interstitium by capillary recruitment
```

```

p2 = p(3); % [1/min] rate of absorption of D-glucose from intestine of
insulin
%action
DS = p(4); % [1/min] amount of D-glucose absorbed
Kabs = p(5); % [1/min] rate of absorption of glucose absorbed from the gut
into
%blood plasma
Beta = p(6); % [1/min] rate of emptying of stomach followed by insulin emptying (beta/1). If
beta < 1
stomach emptying followed by insulin emptying (beta/1). If
beta > 1
stomach emptying followed by
%the opposite of emptying.
k = p(7); % [1/s] time constant of insulin emptying
V = p(8); % [1/min] volume of blood plasma (volume per unit of
body
%weight)
p4 = p(9); % [ml (p4*min)] rate of transport of plasma glucose into
interstitial fluid
p5 = p(10); % [1/min] rate of glucose production by liver into
blood
%plasma
p6 = p(11); % [1/min] rate of transport of glucose to muscle
SIcap = p(12); % [1 (p6*min)] the affinity of insulin to stimulate
insulin
%production
%liver blood plasma to interstitial fluid by secondary recruitment
SIliver = p(13); % [1 (p13*min)] the affinity of insulin to inhibit
hepatic
%production and stimulate glucose uptake by liver
SIglut4 = p(14); % [1 (p14*min)] the affinity of insulin to stimulate
glucose
%clearance in muscle by GLUT4 translocation
Coeff = p(15); % [1] constant network weight of labeled glucose
divided
%by the sum of labeled glucose and glucose

%calculate c_insulin by interpolation of t_c_insulin
u = interp1(t_c_insulin(:,1),t_c_insulin(:,2), t);

%ode's

dG= -((SIliver/10000) + (p4))*(Lin(idG)-Gb)*(u-Ib)+p5-(p6/10)*...
(Lin(idG)-Gb)+(Kabs*Lin(idGgut))/V ;
dGL=0;
%dGL= -((SIliver/10000) + (p4/1))*(Lin(idGL))*(u-Ib)
(p6/10)*Lin(idGL)+...
%(Kabs*Coeff*Lin(idGgut))/V ;
dX = -p2*Lin(idX)+(SIcap/1000) *(u-Ib)^2 ;
% dY = SIglut4*Lin(idY)* Lin(idX)+ (p4/1)*(Lin(idG)-Gb)*(u-Ib);
dGgut=(DS*10)*k*Beta*exp(-k*t)^Beta-Kabs*Lin(idGgut);

dLout = [dG; dGL; dX; dY; dGgut];

```



```

%Known constants and initial values of
%K8 [1/μM] the affinity of insulin to regulate glucose from blood
plasma
%t_c_start [min] the start time of the simulation
%I2 [100μM] initial insulin concentration in the interstitial space
%I0 [μ] amount of insulin injected into the blood
%kabs [1/μm] rate constant of insulin absorption from the gut into
blood plasma
%beta [ ] variability of the power-law insulin action and a low
initial empty receptor level by a constant receptor density I0, I1
%beta [ ] the opposite of beta
%k [5] time constant of insulin degradation
%V [1μM] plasma volume
%kpl [1/μm] rate constant of the insulin degradation in the plasma
%ksp [1/μm] rate constant of insulin degradation in the interstitial space
%k7 [1/μm] rate constant of plasma glucose degradation
%Stoip [1/μm*μM] the affinity of insulin to regulate glucose
clear mwe
%The receptor, by being occupied, is treated as
%inactive (t_c_start) the receptor is considered as inactive (t_c_start)
%product of the insulin and the receptor is denoted by I2 (t_c_start)
%Stoip [1/μm*μM] the affinity of insulin to regulate insulin
when bound to plasma
%ksp [1/μm] rate constant of insulin degradation in the interstitial space
%k7 [1/μm*μM] rate constant of plasma glucose degradation
%Stoip [1/μm*μM] the affinity of insulin to regulate glucose
%by the occupied receptor (t_c_start)

%Initial conditions
ode_options =odeset('RelTol',1e-6,'AbsTol',1e-12); % parameters 2-end
%ode_options =odeset('RelTol',1e-6,'AbsTol',1e-12);

[t,L] = ode45(@gluc_ode_new,t_c_insulin(:,1),L0,ode_options,
t_c_insulin,p);

%Output
c_glucose = L(:,1); % [μM] glucose concentration in the blood
c_glucose_labeled = L(:,2); % [μM] labeled glucose concentration
c_interstitial_insulin=L(:,3); % [μM] interstitial insulin concentration
c_interstitial_glucose=L(:,4); % [μM] interstitial glucose concentration
C_Ggut=L(:,5); % [1/kg] glucose in the gut
Coeff=p(15);
c_Ggut_labeled=Coeff*L(:,5); % [1/kg] of labeled glucose in the gut

% Make plots if it is 1
if plt==1
%Plot
figure;
Ib=p(1);
subplot(321);plot(t_c_insulin(:,1),t_c_insulin(:,2),'b');
hold on;
plot(t_c_insulin(:,1),t_c_insulin(:,2),'r');
plot(t_c_insulin(1),t_c_insulin(end)), [Ib Ib], 'b');
plot(t_c_insulin(1),t_c_insulin(end)), [Ib Ib], 'r');
ylabel('Insulin concentration (μM)');

```

```

xlabel('Time [min]');
Title('Insulin and Glucose Concentrations');

%Figure 322
subplot(322); plot(t_c_insulin(:,1), c_interstitial_insulin,
'k-', 'b'); hold on;
xlabel('Time [min]'); ylabel('Concentration [mg/dl]');
Title(TITLE);

%Figure 323
Gb=p(2);
subplot(323); plot(t_c_insulin(:,1), c_glucose, 'k-', 'b'); hold on;
plot([t_c_insulin(1,1) t_c_insulin(end,1)], [Gb Gb], 'r', 'b');
%Baseline level:
xlabel('Time [min]');
ylabel('Glucose Concentration [mg/dl]');
Title(TITLE);

%Figure 324
subplot(324); plot(t_c_insulin(:,1), c_glucose_labeled, 'k-',
'g'); hold on;
%Baseline level:
xlabel('Time [min]');
ylabel('Glucose Concentration [mg/dl]');
Title(TITLE);

%Figure 325
subplot(325); plot(t_c_insulin(:,1), c_interstitial_glucose,
'k-', 'b'); hold on;
xlabel('Time [min]'); ylabel('Concentration [mg/dl]');
Title(TITLE);

%Figure 326
subplot(326);
plot(t_c_insulin(:,1), c_Ggut, 'k-', 'b'); hold on;
xlabel('Time [min]'); ylabel('Concentration [mg/dl]');
Title(TITLE);
end

```



```

% SIIiver, SIglut4, Coeff);

p_estimating = [p_fix(1),p_fix(2), p_fix(3), p_fix(4), p_var(1), ...
    p_fix(5),p_fix(6), p_var(2),p_var(3), p_fix(7),...
    p_fix(8), p_fix(9), p_fix(10), p_var(4),p_fix(11)];

%Simulating the Oral Minimal Model of glucose kinetics using the
estimating
% 11-dimensional parameter space and the interpolated insulin
concentration
% samples for data1.

plt=0; %maxc No plots
[c_glucose_estimating,c_glucose_labeled_estimating,...

c_interstitial_insulin_estimating,c_interstitial_glucose_estimating,...
    c_Ggut_estimating]=gluc_sim_new(L0,t_c_insulin1,
p_estimating,plt,...
    '1 1 1');

%Simulating the Oral Minimal Model of glucose kinetics using the
estimating
% 11-dimensional parameter space and the interpolated insulin
concentration
% samples for data1.

if NoMean==0

    % Interpolating data.
    t_insulin2_interp1 = t_c_insulin2(1,1):1:t_c_insulin2(end,1);% [min]
    c_insulin2_interp1=interp1(t_c_insulin2(:,1),t_c_insulin2(:,2),...
    t_insulin2_interp1);
    t_c_insulin2_interp1(:,1)=t_insulin2_interp1;
    t_c_insulin2_interp1(:,2)=c_insulin2_interp1;

[c_glucose_estimating2_interp1,c_glucose_labeled_estimating2_interp1...
    c_interstitial_insulin_estimating2_interp1,...
    c_interstitial_glucose_estimating2_interp1,...
    c_Ggut_estimating2_interp1]=gluc_sim_new(L0,t_c_insulin2_interp1,
...
    p_estimating,plt,'1 1 1');

% calculating the mean of the interpolated data2 at the data2
samples
GIb=L0(4);
c_interstitial_glucose_estimating2_mean(1,1)=GIb;
i=2;
for r=t_c_insulin2(2:end,1)'
    c_interstitial_glucose_estimating2_mean(i,1)=...
    sum(c_interstitial_glucose_estimating2_interp1(r+1-t_exp:r))/t_exp;
    i=i+1;
end

```



```

else
    [c_glucose_estimating2,c_glucose_labeled_estimating2,...
    c_interstitial_insulin_estimating2,...
    c_interstitial_glucose_estimating2,c_Ggut_estimating2]=...
    gluc_sim_new(L0,t_c_insulin2, p_estimating,plt,...
    '1 1 1 1');
end

%LSQNONLIN: objective function which returns the model error:
%error: minimize the new variable 'q' by using LSQNONLIN
error1 = c_glucose_estimating-data1;
if NoMean==0
error2= c_interstitial_glucose_estimating2_mean-data2;
else %No Mean
error2= c_interstitial_glucose_estimating2-data2;
end

error3=c_glucose_labeled_estimating-data3;

%total model error

% If data with less number of points than the number of variables, the value of errorX
%and data1, data2, equal to the number of variables.
%initial values
error1_new=error1;
error2_new=error2;
error3_new=error3;
data1_new=data1;
data2_new=data2;
data3_new=data3;

if length(error1)>length(error2)
    for q=1:(length(error1)-length(error2))
        error2_new(length(error2)+q)=0;
        data2_new(length(data2)+q)=1; %if data2 is zero, divide by
%zero
        %and add in Line 137.1 to be added to the effect since
error1_new
        %and error2_new is already set
    end
    error1_new=error1;
    data1_new=data1;
    error3_new=error3;
    data3_new=data3;
else
for q=1:(length(error2)-length(error1))
    error1_new(length(error1)+q)=0;
    data1_new(length(data1)+q)=1;
    error3_new(length(error3)+q)=0;
    data3_new(length(data3)+q)=1;
end

```

```

        error2_new=error2;
        data2_new=data2;
    end

    % Error estimation process
    error1_new = C1 * (param15 * (data2_new - c_interstitial_insulin_estimating)) + ...
    C2 * (param16 * (data2_new - c_glucose_estimating)) + error3_new;
    error=1e4*error1_new+1e4*error2_new+125*1e4*error3_new;

    % Plotting and estimation process
    if 0
    figure(100)
    subplot(411);
    plot(t_c_insulin1(:,1),c_interstitial_insulin_estimating,'b');
    xlabel('Time (min)');
    ylabel('Insulin concentration (mU/L)');
    Title({'Insulin concentration (mU/L) vs Time (min)'});
    drawnow;pause(.3);

    subplot(412);
    plot(t_c_insulin1(:,1),c_glucose_estimating,'b',t_c_insulin1(:,1),...
        data1,'r');
    xlabel('Time (min)');
    ylabel('Glucose concentration (mg/dL)');
    Title({'Glucose concentration (mg/dL) vs Time (min)'});
    drawnow;pause(.3);

    subplot(413);
    plot(t_c_insulin1(:,1),c_glucose_labeled_estimating,'b',t_c_insulin1...
        (:,1),data3,'r');
    xlabel('Time (min)');
    ylabel('Glucose concentration (mg/dL)');
    Title({'Glucose concentration (mg/dL) vs Time (min)'});
    drawnow;pause(.3);

    figure(100)
    subplot(414);
    if NoMean==0
    plot(t_c_insulin2(:,1),c_interstitial_glucose_estimating2_mean,'b',...
        t_c_insulin2(:,1),data2,'r');
    else
    plot(t_c_insulin2(:,1),c_interstitial_glucose_estimating2,'b',...
        t_c_insulin2(:,1),data2,'r');
    end
    xlabel('Time (min)');
    ylabel('Glucose concentration (mg/dL)');

```

## D.2 model2model adjustment

### D.2.1

#### model2model\_bias\_new.m

```
%%%
%Oral Minimal Model of glucose and insulin
%
%This script identifies a posteriori the Oral Minimal Model of glucose
%kinetics using the model2model adjustment approach for each
%iteration
%of the 14 dimensional parameter space
%%
%
%History
%22 March 06, Salvador Almagro Frutos, TU/e
%%

%Initializes all parameters of the OMM for all time samples of plasma
%insulin.
clear all;
NoMean=0;%Calculate the mean over N_simplicates of interstitial glucose
%samples if set to 0
gluc_param2_new;
Nparameters=length(p_true);

%adding noise
data1_new=data1;
%data1_new=data1+(0.025 * randn(10,10000,1));%0.5% FUIB
data2_new=data2;
%data1_new=data2+(0.05 * randn(10,10000,1));
data3_new=data3;
%data1_new=data3+(0.02 * randn(10,10000,1));

%Vector containing variation coefficients (%) for the true 14
dimensional
parameter space
rr=[-0.5 -0.45 -0.4 -0.35 -0.3 -0.25 -0.2 -0.15 -0.1 0 0.1 ....
    0.15 0.2 0.25 0.3 0.35 0.4 0.45 0.5];
r1=[ 0.2 -0.1 0 0.1 0.2 ];
r2=[ 0.5 -0.1 -0.2 -0.1 0 0.1 -0.1 -0.2 -0.1 ];

%Names of the 14 dimensional parameter space
pnames = ['IB' ; 'ab' ; 'b' ; 'b1' ; 'b2' ; 'b3' ; 'b4' ; 'b5' ; 'b6' ; 'b7' ; 'b8' ; 'b9' ; 'b10' ; 'b11' ; 'b12' ; 'b13' ; 'b14'];
pnames = ['Kabs' ; 'Beta' ; 'K' ; 'K1' ; 'K2' ; 'K3' ; 'K4' ; 'K5' ; 'K6' ; 'K7' ; 'K8' ; 'K9' ; 'K10' ; 'K11' ; 'K12' ; 'K13' ; 'K14'];
pnames = ['p1' ; 'p2' ; 'p3' ; 'p4' ; 'p5' ; 'p6' ; 'p7' ; 'p8' ; 'p9' ; 'p10' ; 'p11' ; 'p12' ; 'p13' ; 'p14'];
pnames = ['p1' ; 'p2' ; 'p3' ; 'p4' ; 'p5' ; 'p6' ; 'p7' ; 'p8' ; 'p9' ; 'p10' ; 'p11' ; 'p12' ; 'p13' ; 'p14'];
```

```

pname = ['P1', 'P2', 'P3', 'P4', 'P5', 'P6', 'P7', 'P8', 'P9', 'P10', 'P11', 'P12', 'P13', 'P14', 'P15', 'P16', 'P17', 'P18', 'P19', 'P20', 'P21', 'P22', 'P23', 'P24', 'P25', 'P26', 'P27', 'P28', 'P29', 'P30', 'P31', 'P32', 'P33', 'P34', 'P35', 'P36', 'P37', 'P38', 'P39', 'P40', 'P41', 'P42', 'P43', 'P44', 'P45', 'P46', 'P47', 'P48', 'P49', 'P50', 'P51', 'P52', 'P53', 'P54', 'P55', 'P56', 'P57', 'P58', 'P59', 'P60', 'P61', 'P62', 'P63', 'P64', 'P65', 'P66', 'P67', 'P68', 'P69', 'P70', 'P71', 'P72', 'P73', 'P74', 'P75', 'P76', 'P77', 'P78', 'P79', 'P80', 'P81', 'P82', 'P83', 'P84', 'P85', 'P86', 'P87', 'P88', 'P89', 'P90', 'P91', 'P92', 'P93', 'P94', 'P95', 'P96', 'P97', 'P98', 'P99', 'P100'];

%Model for model adjustment approach for each dimension (P1,P2) of
the
%14-dimensional parameter space(p).

%P1=p(1),P2=p(2); P1=p(1),P2=p(2);... P1=p(1),P2=p(10)
%P1=p(2),P2=p(3); P1=p(3),P2=p(4);... P1=p(2),P2=p(10)
%P1=p(3),P2=p(4); P1=p(3),P2=p(4);... P1=p(3),P2=p(10)
%...
%P1=p(9),P2=p(10);

%Initialize the 14-dimensional parameter space
for qq=[5 8 9 13 14] %qq=[1 2 3 4 5 6 7 8 9 10 11 12 13 14] %qq=[1:(Nparameters-1)]

    estimator(1)=qq;

    %Initialize the 2nd estimator parameter (P2)
    for yy=[5 8 9 13 14] %yy=[1 2 3 4 5 6 7 8 9 10 11 12 13 14]
        bb=1;
        if yy>qq

            estimator(2)=yy; %estimator(2)=yy;

            % saves all other parameters of the 14-dimensional parameter
            space.
            p_fix=[];
            for zz=1:Nparameters
                if zz~=estimator(1)
                    if zz~=estimator(2)
                        p_fix=[p_fix p_true(zz)];
                    end
                end
            end

            for ii=1:length(rr)

                for jj=1:length(rr)

                    %initialisation of the 14-dimensional parameter space which
                    will
                    %be estimated.
                    initial_start_value_parameter=[p_true(estimator(1))
                    p_true(estimator(2))]
                    p_init=[p_true(estimator(1))+rr(ii)*p_true(estimator(1)) ...
                    p_true(estimator(2))+rr(jj)*p_true(estimator(2))];

```

```

%Error function of the 3-dimensional parameter
%space of the Star Minimal Model (3-dimensional kinetics)
plt=0; %Make no plots
iii=ii
jjj=jj

[resnorm]=gluc_omm_mls2_new(data1,data2,data3,L0,t_c_insulin1,...
t_c_insulin2,a,b,c,sigma1,sigma2,sigma3,p_true,p_fix,p_init,...
t_exp,Nparameters,estimator,NoMean,plt);
%Saving the squared norm of the error function residual
DataZ(ii,jj)=resnorm;

%Saving both true parameters for plotting purpose (P1,P2)
if rr(ii)==0 && rr(jj)==0
    resnormTrue=resnorm;
end

%Saving both true parameters for plotting purpose (P1,P2)
if ii==4 && jj==2 ||...
    ii==2 && jj==3 ||ii==4 && jj==8 || ...
    ii==15 && jj==7 || ii==6 && jj==11 ...
    || ii==8 && jj==3 || ii==12 && jj==5 || ii==3 && jj==14
|| ...
    ii==18 && jj==6 || ii==19 && jj==13 || ...
    ii==12 && jj==9 || ii==11 && jj==3

clear all;

[p_model,L0_model,c_glucose_model,c_glucose_labeled,...
c_interstitial_insulin_model,c_interstitial_glucose_model,...
c_Ggut_model,resnorm,residual,varp,stdp]=gluc_omm_mls_bias_new...
(data1_new,data2_new,data3_new,L0,...
t_c_insulin1,t_c_insulin2,a,b,c,sigma1,sigma2,sigma3,...
p_fix,p_init,t_exp,Nparameters,estimator,NoMean,plt);
ptrue1=p_true(qq) % true 1st parameter
ptrue2=p_true(yy) % true 2nd parameter
estimation(bb,:)= [p_model(qq) p_model(yy)]
bb=bb+1;
end

%Saving the error function (1) with 10% variation
DataY(jj)=p_true(estimator(2))+rr(jj)*p_true(estimator(2));
end
%Saving the 1st parameter (1) with 10% variation
DataX(ii)=p_true(estimator(1))+rr(ii)*p_true(estimator(1));
end

% Makes 3d plots of the error function (estimator1, estimator2)
%Contour Lines: 200;
Minn=min(min(DataZ))

```



## D.2.2

### gluc\_param2\_new.m

```
%
%Oral Minimal Model of glucose kinetics.
%
%This script initializes all parameters of the Oral Minimal Model of
%glucose and the time samples of glucose amounts.
%
%
%History
%22 March 06, Salvador Almacro-Estrada, ITIC
%29 Jan-04, Natal van Riel, ITIC
%12-Jun-03, Natal van Riel, ITIC
%*%

close all;
% make plots if plot=1
plt=1;

%fixed model parameters:
%Values from: 2221222

if 1 %Subject no: 5, Visit 0, Day 15
Ib = 7.0625*(7.5+6.5)/2; % [mM] baseline insulin concentration in plasma
Gb = 0.055*(112+119)/2; % [mM] baseline glucose concentration in plasma
GIb=3.38; % [mM] baseline glucose concentration in interstitium
end

if 0 % Subject no: 15, Visit 0, Day 15
Ib = 7.0625*(6.4+4.5)/2; % [mM] baseline insulin concentration in plasma
Gb = 0.055*(112+93)/2; % [mM] baseline glucose concentration in plasma
GIb=3.38; % [mM] baseline glucose concentration in interstitium
end

if 0 % Subject no: 8, Visit 0, Day 15
Ib = 7.0625*(7.8 + 7.6)/2; % [mM] baseline insulin concentration in
plasma
Gb = 0.055*(165+169)/2; % [mM] baseline glucose concentration in plasma
GIb=3.38; % [mM] baseline glucose concentration in interstitium
end
%Known unknown model parameters
% (Mean) values obtained from animal studies (patient):
%
%Annual International Conference of the IEEE Engineering in Medicine
and
%Biology, Cancun, Mexico, 11-21 September 2003,
%Natalucci, S., and E. Di Narzo, P. Stafforini, C. De Marzo, P.
Moresini,
%K. Rupaatti,
%“Absorption and Insulin Sensitivity from Oral Glucose Tolerance Test,”
%Proceedings of the 25th Annual International Conference of the
```

```

%Efficiency of insulin to stimulate
%recruitment of insulin
k8 = 3e-2; % [1/pM] the efficiency of insulin to stimulate
%glucose recruitment by insulin by insulin recruitment
p2 = 0.113; % [1/pM] rate constant of insulin recruitment of insulin
%action
DS = 75/10; % [10]; % [1] insulin concentration in the compartment scaled by
factor
%1/10
Kabs = 2.89e-2; % [1/min] rate constant of absorption of glucose from the
gut
%into blood plasma
Beta = 1.23; % a variable of the slow exponential decay detected in slow
%initial compartment of slow decay of insulin from the cell. It
beta as 1
%the opposite occurs.
k = 0.014; % [1/min] times of insulin in insulin compartment
V = 2.497e-1; % [100k] plasma volume of insulin in volume per cell of
body
%weight (1.8e6) of 180 (1.8e6)
p5 = 0.018; % [1/min] rate constant of insulin clearance by liver into
%blood plasma.
p6 = 0.00763*10; % [1/min] rate constant of insulin glucose to muscle
%scaled
%by factor 10
k7 = 0.063*(1/0.21); % [1/min] rate constant of insulin glucose into remote
%compartment
Sicap = 2e-3*0.0395*(1/0.21)*1e3; % [1/min] rate constant of insulin
to
%stimulate insulin recruitment of insulin by insulin
%recruitment scaled by factor 10
SIliver = 1.11e-5*1e4*(1/7.0625); % [1/min * 1/pM] the efficiency of
insulin to
%inhibit hepatic production and stimulate insulin uptake by liver.
%Scaled by factor 1e4
SIglut4 = 1.0e-2; % [1/min * 1/pM] the efficiency of insulin to stimulate
%glucose clearance in muscle by insulin recruitment of insulin
p4 = k7*k8; % [1/min * 1/pM] rate constant of insulin glucose into
remote compartment
%scaled by factor 10
Coeff = 3/75; % [1] coefficient of insulin concentration that we divide it
%by the sum of label for that compartment.

```

```

p_true = [Ib, Gb, p2, DS, Kabs, Beta, k, V, p4, p5, p6, Sicap, ...
          SIliver, SIglut4, Coeff]; % 14 dimensional parameter space

```

```

%Fixed initial condition
L0(1) = Gb; % [pM] glucose concentration in plasma
L0(2) = 0; % [pM] insulin concentration in insulin compartment
L0(3) = 0; % [pM] insulin concentration in insulin compartment
L0(4) = GIB; % [pM] glucose concentration in insulin compartment
L0(5) = 0; % [1/kg] glucose concentration in the gut

```



```

%Input: insulin concentration in plasma (uIU); assumed to be known at
each
%simulation time sample from 15 to 240 minutes; 15 min measured
samples

%time and amplitude samples of glucose insulin:
if 1 %Subject no: 5; Visit: 6; Day: 1
M1 > blood glucose data
t_insulin1 = [0 15 30 45 60 90 120 180 240];
c_insulin1 = 7.0625*[(7.5+6.5)/2 12.2 19 20.5 23.3 24.6 23.9 27.7 23];
t_c_insulin1 = [t_insulin1' c_insulin1'];

%2 > interstitial glucose data
t_insulin2 = [0 15 30 45 60 90 120 180 240];
c_insulin2 = 7.0625*[(7.5+6.5)/2 12.2 19 20.5 23.3 24.6 23.9 27.7 23];
t_c_insulin2 = [t_insulin2' c_insulin2'];
end

if 0 % Subject no: 15; Visit: 6; Day: 15
M1 > blood glucose data
t_insulin1 = [0 15 30 45 60 90 120 180 240];
c_insulin1 = 7.0625*[(6.4+4.5)/2 14.8 22.2 27 27.7 46.8 81 46 7.];
t_c_insulin1 = [t_insulin1' c_insulin1'];

%2 > interstitial glucose data
t_insulin2 = [0 15 30 45 60 90 120 180 240];
c_insulin2 = 7.0625*[(6.4+4.5)/2 14.8 22.2 27 27.7 46.8 81 46 7.];
t_c_insulin2 = [t_insulin2' c_insulin2'];
end

if 0 % Subject no: 8; Visit: 6; Day: 15
M1 > blood glucose data
t_insulin1 = [0 15 30 45 60 90 120 180 240];
c_insulin1 = 7.0625*[(7.8 + 7.6)/2 13.4 19.7 20.2 21.5 29.6 27.5 18.8
14.2];
t_c_insulin1 = [t_insulin1' c_insulin1'];

%2 > interstitial glucose data
t_insulin2 = [0 15 30 45 60 90 120 180 240];
c_insulin2 = 7.0625*[(7.8 + 7.6)/2 13.4 19.7 20.2 21.5 29.6 27.5 18.8
14.2];
t_c_insulin2 = [t_insulin2' c_insulin2'];
end
% squared 2 norm of the error function residuals

a=1; %output weighting factor of plasma glucose concentration (1st
output)
b=1; % output weighting factor of interstitial glucose concentration
% (2nd output)
c=1; % output weighting factor of plasma labeled glucose concentration
% (3rd output)

sigma1=1; %variance of plasma glucose concentration (1st output)
sigma2=1; % variance of interstitial glucose (2nd output)
sigma3=1; % variance of plasma labeled glucose (3rd output)

```

```

%Plots

% make plots if plt=1
if plt==1;

figure; plot(t_c_insulin1(:,1), t_c_insulin1(:,2), 'b'); hold
%baseline level:
plot([t_c_insulin1(1,1) t_c_insulin1(end,1)], [Ib Ib], 'r', 'LineWidth',1.5)
xlabel('Time (min)'); ylabel('Insulin concentration (mU/L)');
title('Glucose and insulin concentration')
end

%Simulating the oral Minimal Model of glucose kinetics using the TKT
%14-dimensional parameter space and the interpolated insulin
concentration
%samples for data1.
p_sampleInterval = [true] * t_exp;
t_exp=15;

[c_glucose1,c_glucose_labeled1,c_interstitial_insulin1,...
c_interstitial_glucose1,c_Ggut1,c_Ggut_labeled1]=...
gluc_sim_new (L0,t_c_insulin1,p_true,plt,'NoMean=0');

if NoMean==0
% Interpolated data2
t_insulin2_interp1 = t_c_insulin2(1,1):1:t_c_insulin2(end,1); % [min]
c_insulin2_interp1=interp1(t_c_insulin2(:,1),t_c_insulin2(:,2),...
t_insulin2_interp1);
t_c_insulin2_interp1(:,1)=t_insulin2_interp1;
t_c_insulin2_interp1(:,2)=c_insulin2_interp1;

% simulation generated
[c_glucose_interp1,c_glucose_labeled_interp1,...
c_interstitial_insulin_interp1,c_interstitial_glucose_interp1,...
c_Ggut_interp1,c_Ggut_labeled_interp1]...
=gluc_sim_new (L0,t_c_insulin2_interp1,p_true,plt,'NoMean=0');

% calculating the mean of the interpolated data2 at the data2
samples
GIb=L0(4);
c_interstitial_glucose_mean(1,1)=GIb;
i=2;
for r=t_c_insulin2(2:end,1)'
c_interstitial_glucose_mean(i,1)=...
sum(c_interstitial_glucose_interp1(r+1-t_exp:r))/t_exp;
i=i+1;
end
else
% simulation generated
[c_glucose2,c_glucose_labeled2,c_interstitial_insulin2,...
c_interstitial_glucose2,c_Ggut2,c_Ggut_labeled2]....

```

```

    =gluc_sim_new (L0,t_c_insulin2,p_true,plt,'c_glu_1');
end

%data vector of the Oral Minimal Model of glucose kinetics using the
true
15 dimensional parameter space and the interpolated insulin
concentration
    samples.

%data1: data of plasma glucose [mM]
data1=c_glucose1;
% sample interval [min] of data 2 and 3: (tu_2mm_min
t_exp=15;
%data2: data of interstitial glucose [mM]
if NoMean==0
data2=c_interstitial_glucose_mean;
else
data2=c_interstitial_glucose2;
end
%data3: data of plasma labeled glucose [mM]
data3=c_glucose_labeled1;

```

## D.2.3

### gluc\_omm\_mls2\_new.m

```
function
[resnorm]=gluc_omm_mls2_new(data1,data2,data3,L0,t_c_insulin1,...
    t_c_insulin2,a,b,c,sigma1,sigma2,sigma3,p,p_fix,p_init, t_exp, ...
    Nparameters,estimator,NoMean,plt)
%
%GLUC_OMM_MLS2 Maximum likelihood estimation of the oral Minimal
Model
%of glucose kinetics
%
%
%This function estimates the parameters of the maximum likelihood
%estimation of the oral Minimal Model of glucose kinetics using the
%parameters defined in the _parameters_
%
%function
%[resnorm]=gluc_omm_mls2_new(data1,data2,data3,L0,t_c_insulin1,...
%    t_c_insulin2,a,b,c,sigma1,sigma2,sigma3,p,p_fix,p_init, t_exp,
%    Nparameters,estimator,NoMean,plt)
%
%
%Inputs and outputs
%data1: data of plasma glucose (dimensioned the true 14 dimensional
%parameter space) and the interstitial glucose concentration samples.
%data2: data of interstitial glucose (dimensioned the true 14 dimensional
%parameter space) and the interstitial insulin concentration samples.
%data3: data of labeled plasma glucose (pM) over the true 14
dimensional
%parameter space and the interstitial insulin concentration samples.
%L0: Fixed initial concentration of glucose (pM) plasma glucose
concentration,
%L0(2) = [pM] plasma insulin concentration, L0(3) = [pM]
interstitial
%insulin concentration, L0(4) = interstitial glucose concentration [pM],
%L0(5) = [kg] glucose concentration in the gut,
%t_c_insulin: [pM] [min] Time and amplitude samples matrix of plasma
%insulin. 1 x blood glucose data 2 x interstitial glucose data
%a: output weighting factor of 1st output
%b: output weighting factor of 2nd output
%c: output weighting factor of 3rd output
%sigma1: variance of 1st output
%sigma2: variance of 2nd output
%sigma3: variance of 3rd output
%pt = [p1, p2, p3, p4, p5, p6, p7, p8, p9, p10, p11, p12, p13, p14, ...
%SH1ver1, SH1ver2, ...]; %columns of all parameter space,
%p_fix: parameter space dimension vector
%p_init: initial values of parameters space which will be estimated.
%t_exp: sample interval [min] of data.
%Nparameters: number of dimensional parameters space p.
%estimator: defines the parameter adjustment used in the model to model
%adjustment method string.
```

```

%kOMean: If set to zero, do not calculate the mean over t_exp minutes
of
%interstitial glucose samples.
%plt: plots are made in this function (default).
%
%Outputs function:
%resnorm: squared L2 norm of the model-fitted residual.
%%%
%
%History
%2 March 06, Salvador Alvarez-Lacort, IP
%29 Jan 04, Natal van Riel, IP
%17 Jun 03, Natal van Riel, IP
%
%
%new 14-dimensional parameter space
M = [Ib, Gb, p2, D3, Ksp, Isp, k, tau, v0, p5, v0, Mdep, ...
      G1dep, G1dep1, ...];
p_model = [];
offset=0;

for ww=1:Nparameters
    if ww==estimator(1) %search the first estimated parameter and save it
        %at the correct position in the pre-defined 14-dimensional
parameter
        %space (vector (p_model))
        offset=offset+1;
        p_model=[p_model p_init(1)];
    elseif ww==estimator(2) %search the second estimated parameter and
        %save it at the correct position of 14-dimensional
parameter
        %space (vector (p_model))
        offset=offset+1;
        p_model=[p_model p_init(2)];
    else %save all the other parameters at the correct position of
        %14-dimensional parameter space (p_model)
        p_model=[p_model p_fix(ww-offset)];
    end
end

%simulate the Oral Minimal Model (with its kinetics) using the TRF
14-dimensional parameter space and the interpolated insulin
concentration
%samples for data.
[c_glucose1,c_glucose_labeled1,c_interstitial_insulin1,...
 c_interstitial_glucose1,c_Ggut1,c_Ggut_labeled1]....
=gluc_sim_new(L0,t_c_insulin1,p_model,plt,'1111');

if NoMean==0
    % Interpolating data:
    t_insulin2_interpl = t_c_insulin2(1,1):1:t_c_insulin2(end,1); %[min]
    c_insulin2_interpl=interp(t_c_insulin2(:,1),t_c_insulin2(:,2),...
    t_insulin2_interpl);
    t_c_insulin2_interpl(:,1)=t_insulin2_interpl;
    t_c_insulin2_interpl(:,2)=c_insulin2_interpl;

```

```

[c_glucose_interp1,c_glucose_labeled_interp1,...
c_interstitial_insulin_interp1,c_interstitial_glucose_interp1,...
c_Ggut_interp1,c_Ggut_labeled_interp1]....
=gluc_sim_new (L0,t_c_insulin2_interp1,p_model,plt,'t_c_insulin2');

% calculating the mean of the interpolated data2 at the data2
samples
GIb=L0(4);
c_interstitial_glucose_mean(1,1)=GIb;
i=2;
for r=t_c_insulin2(2:end,1)'
c_interstitial_glucose_mean(i,1)=...
sum(c_interstitial_glucose_interp1(r+1-t_exp:r))/t_exp;
i=i+1;
end

else
% simulation with data2
[c_glucose2,c_glucose_labeled2,c_interstitial_insulin2,...
c_interstitial_glucose2,c_Ggut2,c_Ggut_labeled2]....
=gluc_sim_new (L0,t_c_insulin2,p_model,plt,'t_c_insulin2');
end

% error function residuals
error1=c_glucose1-data1;

if NoMean==0
error2=c_interstitial_glucose_mean-data2;

else
error2=c_interstitial_glucose2-data2;
end

error3=c_glucose_labeled1-data3;

%total model error

% if datasets have different number of samples, the dimensions of
errorX
%and dataX are set equal (rows are the
%initial values
error1_new=error1;
error2_new=error2;
error3_new=error3;
data1_new=data1;
data2_new=data2;
data3_new=data3;

if length(error1)>length(error2)
for q=1:(length(error1)-length(error2))
error2_new(length(error2)+q)=0;
data2_new(length(data2)+q)=1; % if not set to 1, error will be divide by
zero
end

```

```

% occurs in line 127. It does not have negative effect since
error1_new
% if error2_new is already not
end
error1_new=error1;
data1_new=data1;
error3_new=error3;
data3_new=data3;
else
for q=1:(length(error2)-length(error1))
error1_new(length(error1)+q)=0;
data1_new(length(data1)+q)=1;
error3_new(length(error3)+q)=0;
data3_new(length(data3)+q)=1;
end
error2_new=error2;
data2_new=data2;
end

% squared 2 norm of the error function residuals
resnorm1=1*(1/length(error1))*sum((error1_new).^2);
resnorm2=1*(1/length(error2))*sum((error2_new).^2);
resnorm3=125*1*(1/length(error3))*sum((error3_new).^2);

% total squared 2 norm of the error function residuals
resnorm=1/3*resnorm1+resnorm2+1/3*resnorm2+resnorm3/3+resnorm3;
resnorm=resnorm1+resnorm2+resnorm3;

```







```

end

%Accuracy:
%lsqnonlin returns the Jacobian (J) as a matrix
varp = resnorm*inv(jacobian'*jacobian)/length(t_c_insulin(:,1));%
variance
stdp = sqrt(diag(varp)); %the standard deviation is the square root
%of the variance

% 14 dimensional parameter space
%p: = [I0, G0, k2, I0, kabs, beta, alpha, phi, phi, phi, phi, phi, phi, phi, phi];
%SI liver, SI gut, SI test];
p_model = [];
offset=0;

for ww=1:Nparameters
    if ww==estimator(1) %search the 14 estimated parameter and save it
        %at the start of position of the pre-defined 14 dimensional
parameter
        %space vector (p_model)
        offset=offset+1;
        p_model=[p_model p_estimated(1)];
    elseif ww==estimator(2) %search the 23 estimated parameter and
save it at the start of position of 14 dimensional
parameter
        %space vector (p_model)
        offset=offset+1;
        p_model=[p_model p_estimated(2)];
    else %save all the other parameters at the correct position of
%14 dimensional parameter space (p_model)
        p_model=[p_model p_fix(ww-offset)];
    end
end
end

L0_model = [p_fix(2),0,0,0];

% make plots with new 14 dimensional parameter space if plt=1
[c_glucose_model,c_glucose_labeled_model,c_interstitial_insulin_model,
...
c_interstitial_glucose_model,c_ggut_model]= gluc_sim_new (L0,...
t_c_insulin1,p_model,plt,'*');

```

## D.2.5

### obj\_fn\_bias\_new.m

```
function error = obj_fn_bias_new(p_var, p_fix, L0, data1, data2,
data3,...
    t_c_insulin1,t_c_insulin2,a,b,c,sigma1,sigma2,sigma3,...
    t_exp,Nparameters,estimator,NoMean)

pvar=p_var
%
% Objective function: Maximum Likelihood Estimation of the Oral
% Model of glucose kinetics.
%
%
% This function is used as objective function for LSQNONLIN.
%
% Function:
% obj_fn_bias_new(p_var, p_fix, L0, data1, data2, t_c_insulin1,...
% t_c_insulin2,a,b,c,sigma1,sigma2,sigma3,t_exp, 'parameters')
%
% Inputs function:
% p_var: parameter space which will be estimated.
% p_fix: parameter space which is fixed.
% L0: Fixed initial concentration, [mg] = [pM] plasma concentration in
% plasma,  $10^{-12}$  [pM] concentration of insulin in plasma,
% [pM] = [mM] glucose concentration in plasma,  $10^{-6}$  [mM]
% glucose concentration in plasma.
% data1: data of unlabeled glucose (mg) = [pM].
% data2: data of unlabeled glucose (pM).
% data3: data of labeled glucose (mg) = [pM].
% t_c_insulin1: [pM] [mg] Time and amplitude samples matrix of plasma
% insulin1 = blood glucose data = time of unlabeled glucose data.
% w1: output weighting factor of 1st output.
% w2: output weighting factor of 2nd output.
% w3: output weighting factor of 3rd output.
% sigma1: variance of 1st output.
% sigma2: variance of 2nd output.
% sigma3: variance of 3rd output.
% t_exp: sample interval [mg] = [pM].
% Nparameters: number of parameters of parameter vector p.
% Estimator: define the pvar of estimator to use in the model (lsqmodel
% or lsqmodel2).
% estimator: define the estimator to use in the model (lsqmodel
% or lsqmodel2).
% NoMean: logical variable (0/1) (0: no mean, 1: mean)
%
% Output function:
% error: minimum variable (0/1) (0: no mean, 1: mean)
%
%
% History
% 02 March 04, Salvador Armas (s.armas@unhcr.org), UNHCR
% 02 Jan 04, Natali van Erp L., UNHCR
% 12 Sep 03, Natali van Erp L., UNHCR
%

```

```

%Estimating 14 dimensional parameter space
%p_true = [L0, G0, I2, I0, Isub, Isub0, k, v, v0, p1, v0, S1exp, ...
%         S1fix, S1dilat];
p_estimating = [];
offset=0;

for ww=1:Nparameters
    if ww==estimator(1) %save all the 14 dimensional parameter and save it
        %at the correct position of the correct 14 dimensional
parameter
        %space vector (p_param)
        offset=offset+1;
        p_estimating=[p_estimating p_var(1)];
    elseif ww==estimator(2) %save all the 14 dimensional parameter and
        %save it at the correct position of 14 dimensional
parameter
        %space vector (p_param)
        offset=offset+1;
        p_estimating=[p_estimating p_var(2)];
    else %save all the other parameter at the correct position of
        %14 dimensional parameter space (p_fix)
        p_estimating=[p_estimating p_fix(ww-offset)];
    end
end

%Simulating the Oral Minimal Model (1) using the estimated
estimated 14
%14 dimensional parameter space and the interpolated insulin
concentration
%samples for data1.

plt=0; % make NO plots
[c_glucose_estimating,c_glucose_labeled_estimating,...

c_interstitial_insulin_estimating,c_interstitial_glucose_estimating,...
c_Ggut_estimating]=gluc_sim_new(L0,t_c_insulin1,
p_estimating,plt,...
'full');

%Simulating the Oral Minimal Model (2) using the estimated
estimated
%14 dimensional parameter space and the interpolated insulin
concentration
%samples for data2.

if NoMean==0

    % Interpolated
t_insulin2_interp1 = t_c_insulin2(1,1):1:t_c_insulin2(end,1); % [min]
c_insulin2_interp1=interp1(t_c_insulin2(:,1),t_c_insulin2(:,2),...
t_insulin2_interp1);
t_c_insulin2_interp1(:,1)=t_insulin2_interp1;
t_c_insulin2_interp1(:,2)=c_insulin2_interp1;

```

```

[c_glucose_estimating2_interp1,c_glucose_labeled_estimating2_interp1...
    c_interstitial_insulin_estimating2_interp1,....
    c_interstitial_glucose_estimating2_interp1,...
    c_Ggut_estimating2_interp1]=gluc_sim_new(L0,t_c_insulin2_interp1,
...
    p_estimating,plt,' III I');

% calculating the mean of the interpolated data2 at the data2
samples
GIb=L0(4);
c_interstitial_glucose_estimating2_mean(1,1)=GIb;
i=2;
for r=t_c_insulin2(2:end,1)'
    c_interstitial_glucose_estimating2_mean(i,1)=...
    sum(c_interstitial_glucose_estimating2_interp1(r+1-t_exp:r))/t_exp;
    i=i+1;
end
else
    [c_glucose_estimating2,c_glucose_labeled_estimating2,...
    c_interstitial_insulin_estimating2,....
    c_interstitial_glucose_estimating2,c_Ggut_estimating2]=...
    gluc_sim_new(L0,t_c_insulin2, p_estimating,plt,...
    ' III I');
end

% SQNONLIN: objective function should return the model error:
%error: minimization variable of MLS (model error)
error1 = c_glucose_estimating-datal;
if NoMean==0
error2= c_interstitial_glucose_estimating2_mean-data2;
else %No Mean
error2= c_interstitial_glucose_estimating2-data2;
end

error3=c_glucose_labeled_estimating-data3;

%total model error

% if datasets have different number of samples, the dimensions of
errorX
%and data are not equal, assign 0 to them
%initial values
error1_new=error1;
error2_new=error2;
error3_new=error3;
datal_new=datal;
data2_new=data2;
data3_new=data3;

if length(error1)>length(error2)
    for q=1:(length(error1)-length(error2))
        error2_new(length(error2)+q)=0;
    end
end

```

```

    data2_new(length(data2)+q)=1; % data2 = 1 (1) since divide by
    zero
    %error1 = (1/2)*t; % error1 = 1/2 (1) since divide by
    error1_new
    %error2 = z_new + data2; % error2 = 1 (1) since divide by
    end
    error1_new=error1;
    data1_new=data1;
    error3_new=error3;
    data3_new=data3;
else
for q=1:(length(error2)-length(error1))
    error1_new(length(error1)+q)=0;
    data1_new(length(data1)+q)=1;
    error3_new(length(error3)+q)=0;
    data3_new(length(data3)+q)=1;
    end
    error2_new=error2;
    data2_new=data2;
end
%error = (a./sigma1.*data1_new).^error1_new+(b./(sigma2.*data2_new)).^4
...
%error2_new+(c./(sigma3.*data3_new)).^error3_new;

error=1e4*error1+1*1e4*error2+125*1e4*error3;
%error = (a./sigma1.*data1_new).^error1_new;
%error = (b./(sigma2.*data2_new)).^4.*error2_new;
%error = (c./(sigma3.*data3_new)).^error3_new;

% plots and save data to a file
if 1
figure(100)
subplot(411);
plot(t_c_insulin1(:,1),c_interstitial_insulin_estimating,'r');
xlabel('time [min]');
ylabel('interstitial insulin [mU/L]');
Title({'Estimating interstitial insulin concentration using...
'beta = 1.0e+004; gamma = 1.0e+004; delta = 1.0e+004;'});
drawnow;pause(.3);

% figure(100)
subplot(412);
plot(t_c_insulin1(:,1),c_glucose_estimating,'r',t_c_insulin1(:,1),...
data1,'b');
xlabel('time [min]');
ylabel('glucose [mg/dL]');
Title({'Estimating glucose concentration using...
'beta = 1.0e+004; gamma = 1.0e+004; delta = 1.0e+004;'});
drawnow;pause(.3);

% figure(100)
subplot(413);
plot(t_c_insulin1(:,1),c_glucose_labeled_estimating,'r',...
t_c_insulin1(:,1),data3,'b');

```

```

xlabel('Time (min)');
ylabel('Insulin (mU/L)');
Title({'Insulin (mU/L) vs Time (min)';...
       'Time: 0 to 100 min; Insulin: 0 to 10 mU/L'});
drawnow;pause(.3);

figure(100)
subplot(414);
if NoMean==0
plot(t_c_insulin2(:,1),c_interstitial_glucose_estimating2_mean,'b',...
      t_c_insulin2(:,1),data2,'r');
else
plot(t_c_insulin2(:,1),c_interstitial_glucose_estimating2,'b',...
      t_c_insulin2(:,1),data2,'r');
end
xlabel('Time (min)');
ylabel('Insulin (mU/L)');
Title({'Insulin (mU/L) vs Time (min)';...
       'Time: 0 to 100 min; Insulin: 0 to 10 mU/L'});
drawnow;pause(.3);
end

```

### D.3 worstcase bias

#### worstcase\_bias\_ss.m

```
function [WorstCase_Bias,estimation]=worstcase_bias_SS()

%  
%Oral Minimal Model of glucose kinetics.  
%  
%This script calculates the worst bias of the Oral Minimal Model of  
%glucose.  
%  
%%  
%  
%history  
%25-08-06, Salvador Almagro-Frutos, 177e  
%%  
%%  
%Function:  
%[WorstCase_Bias]=worstcase_bias()   
%  
%Inputs: function:  
% NONE  
%  
%Outputs: function:  
%WorstCase_Bias: Worst case bias of the model for the identifiable  
%parameters  $p_1, p_2, p_3, p_4, p_5, p_6, p_7, p_8, p_9, p_{10}$ .  
%  
%initialisation  
clear all  
gluc_param_new;  
Nparameters=length(p_true);  
NoMean=0;%Calculates the mean over 1000 iterations of interstitial  
glucose  
%samples if NoMean=0  
  
diary('file', 'worstcase_bias', 'a');  
% Sets the names of the variables containing the estimated parameters:  
filename='worstcase_bias_' + date('mmddyy') + '.mat';  
  
%p1 = [Ib, Gb, p2, p3, Kabs, Beta, S, V, p5, p6, p7, p8, p9, p10];  
%SILiver, SILut4, Coeff]; % 15 interstitial parameter space  
%Ib known parameters:  
p_fix = [Ib Gb p2 DS Beta k p5 p6 SICap SILiver Coeff];  
% using optimal amount  
DS=75/10;% [DS_1,opt] [opt,upper]   
% unknown model parameters:  
p_init = [Kabs V p4 SIglut4];  
  
%  
%-----  
%-----  
% sample schedules with a frequency of 10 minutes for data 1
```



```

t_insulin1_interp1 = t_c_insulin1(1,1):1:t_c_insulin1(end,1); %[min]
c_insulin1_interp1=interp1(t_c_insulin1(:,1),t_c_insulin1(:,2),...
    t_insulin1_interp1);
t_c_insulin1_interp1(:,1)=t_insulin1_interp1;
t_c_insulin1_interp1(:,2)=c_insulin1_interp1;

t_insulin1 =1:1:t_c_insulin1(end,1)
%t_insulin1 = [0 10 20 25 30 35 40 45 50 55 60 65 70 80 90 120 160 240];
%t_insulin1 = [0 15 30 45 60 90 120 150 240];
for uuu=1:length(t_insulin1)
c_insulin1(uuu) = c_insulin1_interp1(t_insulin1(uuu)+1);
end
clear
t_c_insulin1(:,1)=t_insulin1;
t_c_insulin1(:,2)=c_insulin1;
%
% simulation using data1
[c_glucose_model,c_glucose_labeled_model,...
    c_interstitial_insulin_model,...
    c_interstitial_glucose_model,c_Ggut_model]=...
gluc_sim_new(L0,t_c_insulin1, p_true,plt,...
    'c_ggutsim1.m');

if NoMean==0
% interpolation of data1
t_insulin2_interp1 = t_c_insulin2(1,1):1:t_c_insulin2(end,1); %[min]
c_insulin2_interp1=interp1(t_c_insulin2(:,1),t_c_insulin2(:,2),...
    t_insulin2_interp1);
t_c_insulin2_interp1(:,1)=t_insulin2_interp1;
t_c_insulin2_interp1(:,2)=c_insulin2_interp1;

% simulation using data1
[c_glucose_model2_interp1,c_glucose_labeled_model2_interp1,...
    c_interstitial_insulin_model2_interp1,...
    c_interstitial_glucose_model2_interp1,...
    c_Ggut_model2_interp1,c_Ggut_model2_labeled_interp1]....
=gluc_sim_new (L0,t_c_insulin2_interp1,p_true,plt,'c_ggutsim2.m');

% calculating the mean of the interpolated data1 at the data1
samples
GIb=L0(4);
c_interstitial_glucose_mean(1,1)=GIb;
i=2;
for r=t_c_insulin2(2:end,1)'
c_interstitial_glucose_mean(i,1)=...
sum(c_interstitial_glucose_model2_interp1(r+1-t_exp:r))/t_exp;
i=i+1;
end

else
% simulation using data2
[c_glucose_model2,c_glucose_labeled_model2,...
    c_interstitial_insulin_model2,...

```

```

c_interstitial_glucose_model2, c_Ggut_model2, c_Ggut_labeled_model2]...
    =gluc_sim_new (L0,t_c_insulin2,p_true,plt,'NoMean');
end

% adding noise
data1_new=t_insulin1;
data1_new=c_glucose_model;
data1_new=data1_new*(1+0.01*randn(size(data1_new),1)); %1% RUISE
if NoMean==0
data2_new=c_interstitial_glucose_mean;
data2_new=data2_new*(1+0.01*randn(size(data2_new),1)); %1% RUISE
else
data2_new=c_interstitial_glucose_model2;
data2_new=data2_new*(1+0.01*randn(size(data2_new),1)); %1% RUISE
end
data3_new=awgn(c_ggut_labeled_model,'interpl',(1/0.06),'measured',...
    % 'linear'); %1% RUISE measured data
data3_new=c_glucose_labeled_model;

% end initialization

%Calculating the determinant of the Fisher matrix for estimation of the
%identifiable parameters by using the 1, 2, 3, 4 and 5%
p_init_copy=p_init;
b=1;
estimation(1,:)=[-0.5 -0.4 -0.3 -0.2 -0.1 0.1 0.2 0.3 0.4 0.5 ];
estimation1(1,:)=estimation(1,:);
estimation2(1,:)=estimation(1,:);
estimation3(1,:)=estimation(1,:);
estimation4(1,:)=estimation(1,:);

for kk=1:length(p_init)
    ll=0;
    for zz=estimation(1,:);
        p_init=p_init_copy;
        ll=ll+1;

        estimator=find(p_init(kk)==p_true);
        estimator1=find(p_init(1)==p_true);
        estimator2=find(p_init(2)==p_true);
        estimator3=find(p_init(3)==p_true);
        estimator4=find(p_init(4)==p_true);
        %varying the identifiable parameters by 1%
        p_True=p_true(estimator) %only in monitor
        p_init(kk)=p_init(kk)+ zz*p_init(kk)
        [p_model,L0_model,c_glucose_model,c_glucose_labeled_model,...
        c_interstitial_insulin_model,...
        c_interstitial_glucose_model,
        c_Ggut_model, resnorm, residual, varp...
        , stdp]=gluc_omm_mls_new(data1_new,data2_new,data3_new,L0,...
        t_c_insulin1,t_c_insulin2,a,...

b,c,sigma1,sigma2,sigma3,p_fix,p_init,t_exp,Nparameters,NoMean,plt);
    estimator
    p_Model=p_model(estimator) %1% RUISE

```

```

estimation(kk+1,ll)=p_model(estimator);

estimation1(kk+1,ll)=p_model(estimator1);
estimation2(kk+1,ll)=p_model(estimator2);
estimation3(kk+1,ll)=p_model(estimator3);
estimation4(kk+1,ll)=p_model(estimator4);
end

%Calculating worst case
estimation
WorstCase_Bias(b,:)= [p_true(estimator) ...
max(abs(p_true(estimator)-estimation(kk+1,:)))];
b=b+1;
end

TARGET=fopen(filename,'w');
fprintf(TARGET,...
' %10.10e %10.10e %10.10e %10.10e %10.10e\n',
estimation1');
fprintf(TARGET,...
' %10.10e %10.10e %10.10e %10.10e %10.10e\n',
estimation2');
fprintf(TARGET,...
' %10.10e %10.10e %10.10e %10.10e %10.10e\n',
estimation3');
fprintf(TARGET,...
' %10.10e %10.10e %10.10e %10.10e %10.10e\n',
estimation4');
fclose(TARGET);

```

## D.4 A priori parameter sensitivity

### param\_sens\_new.m

```
function [varp_matrix]=param_sens_new()

%%%
%Oral Minimal Model of glucose kinetics [10]
%This function analyzes the a priori parameters used
%during the estimation procedure together with the optimal input.
%It varies the a priori parameters  $\beta_1, \beta_2, \beta_3, \beta_4, \beta_5$  and  $\beta_6$ 
%
%%%
%
%History
%07-july-06, Salvador Almeida-Frutos, IUGV
%%%
%Function:
%[varp_matrix]=param_sens_new()
%
%Inputs function:
% NONE
%
%Outputs function:
%varp_matrix: Determinant of the Fisher matrix for variations of the a
% priori parameters by  $\beta_1, \beta_2, \beta_3, \beta_4, \beta_5$  and  $\beta_6$ 

% Initialization
clear all
gluc_param_new;
Nparameters=length(p_true);
NoMean=0;%calculates the mean over 10 experiments of interstitial
glucose
%samples at NoMean=0

% Sets the names of the matrices containing the estimated parameters:
filename='matrices_';
diary varp_matrix;

% p = [Ib, Gb, p2, DS, Kabs, Peta, k, p1, p4, p5, SIcap, ...
% SIiver, SIglut4, Coeff]; 14 dimensional parameter space
% known parameters:
p_fix = [Ib Gb p2 DS Beta k p5 p6 SIcap SIiver Coeff];
% using optimal input
DS=75/10;%[DS_I_opt] optimum of
% unknown model parameters:
p_init = [1.4*Kabs 1.4*V 1.5*p4 1.5*SIglut4];

% sample scheduler with a frequency of 1 minute for data 1
t_insulin1_interpl = t_c_insulin1(1,1):1:t_c_insulin1(end,1);%[min]
```

```

c_insulin1_interp1=interp1(t_c_insulin1(:,1),t_c_insulin1(:,2),...
    t_insulin1_interp1);
t_c_insulin1_interp1(:,1)=t_insulin1_interp1;
t_c_insulin1_interp1(:,2)=c_insulin1_interp1;

% simulation using data1
[c_glucose_model_interp1,c_glucose_labeled_model_interp1,...
    c_interstitial_insulin_model_interp1,...
    c_interstitial_glucose_model_interp1,c_Ggut_model_interp1]=...
gluc_sim_new(L0,t_c_insulin1_interp1, p_true,plt,...
    'c1' 'c2' 'c3');

if NoMean==0
    % Interpolating data2
    t_insulin2_interp1 = t_c_insulin2(1,1):1:t_c_insulin2(end,1);%[min]
    c_insulin2_interp1=interp1(t_c_insulin2(:,1),t_c_insulin2(:,2),...
    t_insulin2_interp1);
    t_c_insulin2_interp1(:,1)=t_insulin2_interp1;
    t_c_insulin2_interp1(:,2)=c_insulin2_interp1;

    % simulation using data2
    [c_glucose_model2_interp1,c_glucose_labeled_model2_interp1,...
    c_interstitial_insulin_model2_interp1,...
    c_interstitial_glucose_model2_interp1,...
    c_Ggut_model2_interp1,c_Ggut_model2_labeled_interp1]....
    =gluc_sim_new (L0,t_c_insulin2_interp1,p_true,plt,'c1' 'c2' 'c3');

    % calculating the mean of the previously listed data2 of the data2
    samples
    GIb=L0(4);
    c_interstitial_glucose_mean(1,1)=GIb;
    i=2;
    for r=t_c_insulin2(2:end,1)'
        c_interstitial_glucose_mean(i,1)=...
        sum(c_interstitial_glucose_model2_interp1(r+1-t_exp:r))/t_exp;
        i=i+1;
    end

else
    % simulation using data1
    [c_glucose_model2,c_glucose_labeled_model2,...
        c_interstitial_insulin_model2,..

c_interstitial_glucose_model2,c_Ggut_model2,c_Ggut_labeled_model2]...
    =gluc_sim_new (L0,t_c_insulin2,p_true,plt,'c1' 'c2' 'c3');
end

% adding noise
datat_new=t_insulin1_interp1;
data1_new=c_glucose_model_interp1;
data1_new=data1_new+0.05 * randn(length(data1_new),1);%3.6% RBIS
if NoMean==0
data2_new=c_interstitial_glucose_mean;
data2_new=data2_new+0.10 * randn(length(data2_new),1);%1.8% RBIS

```

```

else
data2_new=c_interstitial_glucose_model2;
data2_new=data2_new+0.10 * randn(length(data2_new),1); %10% KUIS%
end
end
data3_new=c_glucose_labeled_model_interp1;

% end initialization

%calculating the determinant of the Fisher matrix for variations of the
%a priori parameters by -30, -20, -10, 0, 10, 20 and 30%.

p_fix_copy=p_fix;
estimation(1,:)=[-0.3 -0.20 -0.1 -0.05 0.05 0.1 0.20 0.30];
estimation1(1,:)=estimation(1,:);
estimation2(1,:)=estimation(1,:);
estimation3(1,:)=estimation(1,:);
estimation4(1,:)=estimation(1,:);
for kk=1:length(p_fix)
    ll=0;
    p_fix=p_fix_copy;
    for zz=estimation(1,:)

        p_init_saved = [Kabs V p4 SIglut4];
        estimator1=find(p_init_saved(1)==p_true)
        estimator2=find(p_init_saved(2)==p_true)
        estimator3=find(p_init_saved(3)==p_true)
        estimator4=find(p_init_saved(4)==p_true)

        ll=ll+1;
        %varying the a priori parameters by +/-10%
        p_fix(kk)=p_fix(kk)+ zz*p_fix(kk)
        [p_model,L0_model,c_glucose_model,c_glucose_labeled_model,...
            c_interstitial_insulin_model,...
            c_interstitial_glucose_model,
            c_Ggut_model,resnorm,residual,varp...
            ,stdp]=gluc_omm_mls_new(data1_new,data2_new,data3_new,L0,...

t_c_insulin1_interp1,t_c_insulin2,a,b,c,sigma1,sigma2,sigma3,...
    p_fix,p_init,t_exp,Nparameters,NoMean,plt);

        estimation1(kk+1,ll)=p_model(estimator1);
        estimation2(kk+1,ll)=p_model(estimator2);
        estimation3(kk+1,ll)=p_model(estimator3);
        estimation4(kk+1,ll)=p_model(estimator4);

        varp_matrix(kk,ll)=det(varp) %used by the model fit

    end
end
end
TARGET=fopen(filename,'w');
fprintf(TARGET,...

    ' ',estimation1');
fprintf(TARGET,...

```

```

    fprintf(TARGET, 'Estimation 2: %f\n', estimation2);
    fprintf(TARGET, 'Estimation 3: %f\n', estimation3);
    fprintf(TARGET, 'Estimation 4: %f\n', estimation4);
    fclose(TARGET);
    varp_matrix=[p_fix' varp_matrix]

```

## D.5 Optimal Input

### opt\_input\_new.m

```
function [DS_T_opt,DS_matrix]=opt_input_new()

%%
%Oral Minimal Model of glucose regulation
%This function calculates the optimal input for the oral Minimal Model
%of glucose using the algorithm of the author [1].
%
%%
%
%History
%07 July 06, Salvador Alberto Fritsch, 10 e
%%
%Function:
%[DS_T_opt,DS_matrix]=opt_input_new()

%Inputs function:
%NONE

%Outputs function:
%DS_T_opt: optimal input.
%DS_matrix: matrix of input. It is a 2x(n) sub-matrix of Fisher matrix
%(end row)

%Initial values
gluc_param_new;
Nparameters=length(p_true);
NoMean=0; %calculate the mean over the experiments of interstitial glucose
%samples
plt=0; %make 0 plots

% Sets the names of the model parameters and the estimated parameters:
filename='oral_minimal_model_optimal_input.m';
diary 'oral_minimal_model_optimal_input.m';

sp = [Ib, Gb, p2, DS, Kabs, beta, k, v, p4, p5, p6, SIcap, ...
      SILiver, SIglut4, Coeff]; % 15-dimensional parameter space
known_parameters =
p_fix = [Ib Gb p2 DS Beta k p5 p6 SIcap SILiver Coeff];
unknown_model_parameters =
p_init = [1.4*Kabs 1.4*V 1.5*p4 1.5*SIglut4];

% sample schedules with a frequency of 1 minute for data 1
t_c_insulin1_interpl = t_c_insulin1(1,1):1:t_c_insulin1(end,1); % [min]
c_insulin1_interpl=interpl(t_c_insulin1(:,1),t_c_insulin1(:,2),...
    t_insulin1_interpl);
t_c_insulin1_interpl(:,1)=t_insulin1_interpl;
t_c_insulin1_interpl(:,2)=c_insulin1_interpl;

% sample schedules with a frequency of 1 minute for data 2
t_c_insulin2_interpl = t_c_insulin2(1,1):1:t_c_insulin2(end,1); % [min]
c_insulin2_interpl=interpl(t_c_insulin2(:,1),t_c_insulin2(:,2),...
```



```

t_insulin2_interp1);
t_c_insulin2_interp1(:,1)=t_insulin2_interp1;
t_c_insulin2_interp1(:,2)=c_insulin2_interp1;

% end initialization

% different values for D0 (initials and t_end D0)
DS_vector=[1:100]./10; % scaled by factor 10 (see differential
equations)
kkz=0;

for z=1:length(DS_vector)
    kkz=kkz+1
    p_init_saved = [Kabs V p4 SIglut4];
    estimator1=find(p_init_saved(1)==p_true)
    estimator2=find(p_init_saved(2)==p_true)
    estimator3=find(p_init_saved(3)==p_true)
    estimator4=find(p_init_saved(4)==p_true)

    % change DS
    DS=DS_vector(z)
    p_true(4)=DS;
    p_fix = [Ib Gb p2 DS Beta k p5 p6 SIcap SIiver Coeff];
    % simulation model 1: time sample scheme with a frequency of 1 minute.
    % see plot of t(1)

[c_glucose_model_interp1,c_glucose_labeled_model_interp1,...
    c_interstitial_insulin_model_interp1,...
    c_interstitial_glucose_model_interp1,c_Ggut_model_interp1]=...
    gluc_sim_new(L0,t_c_insulin1_interp1, p_true,plt,...
    'GIB=1000000');

if NoMean==0
    % Interpolating data?

    % simulation using data?
    [c_glucose_model2_interp1,c_glucose_labeled_model2_interp1,...
    c_interstitial_insulin_model2_interp1,...
    c_interstitial_glucose_model2_interp1,...
    c_Ggut_model2_interp1,c_Ggut_model2_labeled_interp1]=...
    =gluc_sim_new (L0,t_c_insulin2_interp1,p_true,plt,'GIB=1000000');

    % calculating the mean of the first 1000 data of the data2
    samples
    GIB=L0(4);
    c_interstitial_glucose_mean(1,1)=GIB;
    i=2;
    for r=t_c_insulin2(2:end,1)'
        c_interstitial_glucose_mean(i,1)=...
        sum(c_interstitial_glucose_model2_interp1(r+1-t_exp:r))/t_exp;

```

```

        i=i+1;
    end
else
    % simulation using data2
    [c_glucose_model2,c_glucose_labeled_model2, ...
     c_interstitial_insulin_model2,...

c_interstitial_glucose_model2,c_Ggut_model2,c_Ggut_labeled_model2]...
    =gluc_sim_new (L0,t_c_insulin2,p_true,plt,' ');
end

% adding noise
datat_new=t_insulin1_interp1;
data1_new=c_glucose_model_interp1;
data1_new=data1_new+0.025 * randn(length(data1_new),1);
if NoMean==0
data2_new=c_interstitial_glucose_mean;
data2_new=data2_new+0.05 * randn(length(data2_new),1);
else
data2_new=c_interstitial_glucose_model2;
data2_new=data2_new+0.05 * randn(length(data2_new),1);
end
data3_new=c_glucose_labeled_model_interp1;

%plots of data with added noise
% make plots if plt=1
if plt==1
%Plots
figure;
Gb=p_true(2);
subplot(311); plot(datat_new,data1_new,'b', 'linewidth',2);
hold on;
plot(t_c_insulin1_interp1(:,1),c_glucose_model_interp1,'r',
'linewidth',2);
hold on;
plot([datat_new(1) datat_new(end)], [Gb Gb], 'b', 'linewidth',1.5)
%Baseline level:
xlabel('Time [min]');
ylabel('Glucose [mg/dl]');
Title('Plot of t_c_insulin1 and c_glucose_model_interp1');
title('');

%figure
if NoMean==0
subplot(312); plot(t_c_insulin2(:,1), data2_new,'b', 'linewidth',2)
hold on;
plot(t_c_insulin2(:,1),c_interstitial_glucose_mean,'r',...
'linewidth',2);
else
subplot(322); plot(t_c_insulin2(:,1), data2_new,'b', 'linewidth',2)
hold on;
plot(t_c_insulin2(:,1),c_interstitial_glucose_model2,'r',...
'linewidth',2);
end
end

```

```

xlabel('Time (min)'); ylabel('Glucose (mg/dl)');
title('Glucose (mg/dl) vs Time (min)');
hold on;
plot(t_c_insulin1_interp1(:,1),c_glucose_labeled_model_interp1,'r',...
      'LineWidth',2);
hold off;
plot([datat_new(1) datat_new(end)], [Gb Gb], 'b', 'LineWidth',1.5)
%Baseline Level;
xlabel('Time (min)');
ylabel('Glucose (mg/dl)');
title('Glucose (mg/dl) vs Time (min)');
end

%Estimating the model parameters
[p_model,L0_model,c_glucose_model,c_glucose_labeled_model,...
c_interstitial_insulin_model,...
c_interstitial_glucose_model,c_Ggut_model,resnorm,residual,varp,...
stdp]=gluc_omm_mls_new(data1_new,data2_new,data3_new,L0,...
t_c_insulin1_interp1,t_c_insulin2,a,b,c,sigma1,sigma2,sigma3,p_fix,...
p_init,t_exp,Nparameters,NoMean,plt);

if z==1
    varp_old=varp %varp of the previous iteration matrix
    DS_T_opt=DS_vector(z)
else if det(varp)<det(varp_old) %if det of the previous matrix
    varp_old=varp; %varp of the previous iteration matrix
    det(varp) %if det of the previous matrix
    DS_T_opt=DS_vector(z)
end
det(varp)
DS_matrix(z,:)=[DS,det(varp)];

estimation1(kkz)=p_model(estimator1);
estimation2(kkz)=p_model(estimator2);
estimation3(kkz)=p_model(estimator3);
estimation4(kkz)=p_model(estimator4);
end

TARGET=fopen(filename,'w');
fprintf(TARGET,'%f\n',estimation1');
fprintf(TARGET,'%f\n',estimation2');
fprintf(TARGET,'%f\n',estimation3');
fprintf(TARGET,'%f\n',estimation4');
fclose(TARGET);

```



```

DS=75/10; % [DS_Lopt]-opt_inimf (0)

% known parameters:
p_fix = [Ib Gb p2 DS Beta k p5 p6 SIcap SIiver Coeff];
% initial value unknown model parameters:
p_init = [p4, p5, p6, SIcap, SIiver, Iopt];
p_init = [1.4*Kabs 1.4*V 1.4*p4 1.4*SIglut4];

% simulate model using a sample schedule with a frequency of 1 minute
% and using optimal input
make_plots = 1;
plt=0;

% sample schedule for data1 with a frequency of 1 minute
t_insulin1_interp1 =
t_c_insulin1(1,1):1:Max_Exp_Dur;%t_c_insulin1(end,1);
%[min]
c_insulin1_interp1=interp1(t_c_insulin1(:,1),t_c_insulin1(:,2),...
t_insulin1_interp1);
t_c_insulin1_interp1(:,1)=t_insulin1_interp1;
t_c_insulin1_interp1(:,2)=c_insulin1_interp1;

% simulating data1
[c_glucose_model_interp1,c_glucose_labeled_model_interp1,...
c_interstitial_insulin_model_interp1,...
c_interstitial_glucose_model_interp1,c_Ggut_model_interp1]=...
gluc_sim_new(L0,t_c_insulin1_interp1,p_true,plt,...
'linear','linear');

% sample schedules for data2 with a frequency of 1 minute
t_insulin2_interp1 =
t_c_insulin2(1,1):1:Max_Exp_Dur;%t_c_insulin2(end,1);
%[min]
c_insulin2_interp1=interp1(t_c_insulin2(:,1),t_c_insulin2(:,2),...
t_insulin2_interp1);
t_c_insulin2_interp1(:,1)=t_insulin2_interp1;
t_c_insulin2_interp1(:,2)=c_insulin2_interp1;

% simulation using data2
[c_glucose_model2,c_glucose_labeled_model2,...
c_interstitial_insulin_model2,...
c_interstitial_glucose_model2,c_Ggut_model2,c_Ggut_labeled_model2]...
=gluc_sim_new (L0,t_c_insulin2_interp1,p_true,plt,'linear','linear');

% adding noise
datat_new=t_insulin1_interp1;
%data1_new=awgn(c_glucose_model_interp1,(1/0.06),'measured','linear');
...
%16% RMS
data1_new=c_glucose_model_interp1;
%data2_new=awgn(c_interstitial_glucose_model2,(1/0.08),'measured',...
'linear'); %16% RMS; %data2_new=

```

```

data2_new=c_interstitial_glucose_model2;
data3_new=awg(t_c_insulin1_labeled_model_interp1, (1,0,0), 'measured', ...
    % 'linear'); %667.4415*10^-6*10^6*10^6
data3_new=c_glucose_labeled_model_interp1;

%optimal sample schedule

it=1;
%calculating the optimal sample schedule (input 1 and input 3)
%Algorithms based on starting with a conventional sample schedule where
each individual sample is optimized by comparing it with its
neighbouring samples in the conventional sample schedule.

%initialization of conventional sample schedule
opt_data1=data1;
opt_data3=data3;
opt_SS_data1=t_c_insulin1_interp1(:,1);
data1_using=t_c_insulin1_interp1(:,2);

aa=1:1:(2*t_exp-1);
endvalue=1e6;
r=1;

for q=1*t_exp:t_exp:endvalue
    for z=[aa]

        qz=q+z %display on monitor
        %starting with optimization of sample by comparing it with its
        %neighbouring samples in the conventional sample schedule.

        %saving optimal sample schedule and its amplitude
        datat1_using=opt_SS_data1;
        datat1_usingggg=opt_SS_data1' %display on monitor
        data1_using=opt_data1;
        data3_using=opt_data3;

        datat1_using_old=datat1_using' %display on monitor
        datat1_using(q/t_exp+1)=opt_SS_data1(q/t_exp)+z; %saving new sample
        %schedule
        datat1_using_new=datat1_using' %display on monitor

        %procedure if the horizon is supposed to end at a sample which
        %...
        %greater than the last sample of the experiment of the search for
        %...
        % the optimal sample schedule is reached:
        if datat1_using(q/t_exp+1)>=Max_Exp_Dur %at sample of experiment
            %reached
            display('The horizon is reached at sample: ', q)
            aa=1:1:(2-r)*t_exp-1 %the length of the horizon must ...
            %at least end at the last sample taken
    end
end

```

```

        r=r+1;
    if numel(aa)==0
        display(' '); %defining the output placement of opt_sample_schedule_new
which
        %opt_data2 calculated in the inner loop:
        opt_SS_data2=0;
        opt_data2=0;
        return;
    end
end

data1_using_old=data1_using'; %array reposition
data1_using(q/t_exp+1)=data1_new(opt_SS_data1(q/t_exp)+z+1);
%saving data of new sample:
data3_using(q/t_exp+1)=data3_new(opt_SS_data1(q/t_exp)+z+1);
%schedule
data1_new_neww=data1_using'; %array reposition
data3_new_neww=data3_using'; %array reposition

datac1_using_old=datac1_using'; %array reposition
datac1_using(q/t_exp+1)=t_c_insulin1_interp1(opt_SS_data1(q/t_exp)+z+1,
2);
%saving new amplitudes of sample schedule:
datac1_using_new=datac1_using'; %array reposition
datat1_c_using=[datat1_using datac1_using];

%interp1 does not support 2-D arrays, therefore, it is taken at a later time
than one of the following:
if (q/t_exp+2)<=length(datat1_using)
    if datat1_using(q/t_exp+1)==datat1_using(q/t_exp+2)
        pause
        ww=1;
        while (q/t_exp+1+ww)<=length(datat1_using)-1
            datat1_using(q/t_exp+1+ww)= datat1_using(q/t_exp+1+ww)+t_exp
            datac1_using(q/t_exp+1+ww)= datac1_using(q/t_exp+1+ww)+t_exp
            data1_using(q/t_exp+1+ww)=data1_using(q/t_exp+1+ww+1)
            data3_using(q/t_exp+1+ww)=data3_using(q/t_exp+1+ww+1)
            ww=ww+1;
        end
        datat1_using=datat1_using(1:length(datat1_using)-1)
        datac1_using=datac1_using(1:length(datac1_using)-1)
        data1_using=data1_using(1:length(data1_using)-1)
        data3_using=data3_using(1:length(data3_using)-1)
        datat1_c_using=[datat1_using datac1_using];
        opt_SS_data1=datat1_using %saving the current SS
        opt_data1=data1_using %saving the data of the current SS
        opt_data3=data3_using %saving the data of the current SS
    end
end
end

```

```

%calculate the parameter estimates and the corresponding Fisher
%matrix
[p_model,L0_model,c_glucose_model,c_glucose_labeled_model,...
c_interstitial_insulin_model,...
c_interstitial_glucose_model,c_Ggut_model,resnorm,residual,varp,...

stdp]=gluc_omm_mls_new(data1_using,data2,data3_using,L0,datat1_c_using,
...
t_c_insulin2,a,b,c,sigma1,sigma2,sigma3,p_fix,p_init,t_exp,...
Nparameters,NoMean,plt);

if z==aa(1)
    varp_old=varp; %save the old Fisher matrix
    optimumDET=det (varp) %display on monitor
    opt_SS_data1=datat1_using %saving the current SS
    opt_data1=data1_using %saving the data of the current SS
    opt_data3=data3_using %saving the data of the current SS
    SAVED=1; %display on monitor
elseif det (varp)<det (varp_old) %save the Fisher matrix
    varp_old=varp; %save the old determinant of the
Fisher
    optimumSample=qz %display on monitor
    optimumDET=det (varp) %display on monitor
    opt_SS_data1=datat1_using %saving the current SS
    opt_data1=data1_using %saving the data of the current
SS
    opt_data3=data3_using %saving the data of the current
SS
else
    det (varp) %display on monitor
    NOTSAVED=1 %display on monitor
end
end

end

end

if 0
%calculating the optimal sample schedule for input 2
%initialization of consistent optimal sample schedule-
%Algorithm based on starting with a conventional sample schedule where
%each individual sample is taken only once together with its
%neighbouring samples in the conventional sample schedule.

%initialization of sample schedule on the optimal schedule
opt_data2=data2;
opt_SS_data2=t_c_insulin2(:,1);

```



```

aa=t_exp:t_exp:5*t_exp;
endvalue=1e6;
r=1;

for q=1*t_exp:t_exp:endvalue
    for z=[aa]

        qz=q+z; %display the number
        %starting with optimal for the 1st sample, by comparing it with the
        %neighbouring sample, to be a better sample schedule.

        %saving optimal sample schedule and its amplitude
        datat2_using=opt_SS_data2;
        data2_using=opt_data2;

        %calculating the mean of the interpolated data2 at the data2
        %samples
        SumOfData=0;
        if NoMean==0
            for pp=1:1:t_exp
                SumOfData=SumOfData+data2_new(opt_SS_data2(q/t_exp)+z+1-(pp));
                %summing data of new sample
            end
            Meandata=1/t_exp*SumOfData; %Mean of new sample
            data2_using(q/t_exp+1)=Meandata; %saving data of new sample
        else
            data2_using(q/t_exp+1)=data2_new(opt_SS_data2(q/t_exp)+z); %saving
            ...
            data of new sample
        end

        datat2_using_old=datat2_using'; %data of old sample
        datat2_using(q/t_exp+1)=opt_SS_data2(q/t_exp)+z; %saving new sample
        %schedule
        datat2_using_new=datat2_using'; %data of new sample
        data2_new_neww=data2_using'; %data of new sample

        %procedure if the horizon is reached to end at a sample which
        %is greater than the last sample of the experiment or the search for
        %the optimal sample schedule is reached
        if datat2_using(q/t_exp+1)>=Max_Exp_Dur %last sample of experiment
            %reached
            display('The horizon is reached at sample: ' + q)
            aa=t_exp:t_exp:(5-r)*t_exp; %the number of the horizon must ...
            %at least end at the last possible take
            r=r+1;
            if numel(aa)==0
                display('The horizon is reached at sample: ' + q)
                %determining the output of current opt_sample_schedule_new
                which
                %are not calculated in this for loop:
                opt_SS_data1=0
                opt_SS_data3=0
                opt_data1=0
            end
        end
    end
end

```

## D.7 White Noise test

### wnoisetest\_new.m

```
function [datacov,mean_data1,mean_data2,mean_data3]=...
    wnoisetest_new(data1,data2,data3,residual)

%%
%Oral Minimal Model of glucose kinetics T001
%This function analyzes the properties of data used as residuals left
%during the estimation procedure
%
%%
%
%History
%07 July 06, Salvador Almagro Frutos, TU/e
%%
%Function:
%[datacov_data1,mean_data1,mean_data2] =wnoisetest (data1,data2,residual)
%
%Inputs function:
%data1: data of interstitial insulin [pM]
%data2: data of interstitial glucose [mM]
%data3: data of labeled plasma glucose [mM].

%residual: the value of the residual of the estimation algorithm.
%
%Outputs function:
%datacov_data1: crosscorrelation of the data.
%mean_data1: calculating the mean of the data. Must be zero.
%mean_data2: calculating the mean of the data. Must be zero.
%mean_data3: calculating the mean of the data. Must be zero.

% TEST: calculating the mean. Must be zero.
mean_data1=mean(data1);
mean_data2=mean(data2);
mean_data3=mean(data3);

% TEST: Statistical properties: gaussian distribution with zero mean
pp=-1:0.01:1;
yy=hist(residual,pp);
figure;
plot(pp,yy);title('Histogram of residuals');
xlabel('Normalized residuals');
ylabel('Frequency');

% normalizing residuals
residual=residual./max(residual);

% TEST: crosscorrelation. Must be the form of a pulse at zero
timeshift:
for m=0:(length(residual)-round(0.4*length(residual)))
    sum=0;
```

```

    for n=1:(round(0.4*length(residual)))
        part=residual(n)*residual(n+m);
        sum=sum+part;
    end
    datacov(m+1)=(1/(round(0.4*length(residual)))).*sum;
end

figure
plot((0:(length(residual)-round(0.4*length(residual)))),datacov);
title('Residual Covariance');
xlabel('lag');
ylabel('Residual Covariance');

```



```

    % calculating the mean of the interpolated data2 at the data2
    samples
    GIb=L0(4);
    c_interstitial_glucose_mean(1,1)=GIb;
    i=2;
    for r=t_c_insulin2(2:end,1)';
    c_interstitial_glucose_mean(i,1)=...
    sum(c_interstitial_glucose_model2_interp1(r+1-t_exp:r))/t_exp;
    i=i+1;
    end

    else
    % simulation using data2
    [c_glucose_model2,c_glucose_labeled_model2,...
    c_interstitial_insulin_model2,...

c_interstitial_glucose_model2,c_Ggut_model2,c_Ggut_labeled_model2]...
    =gluc_sim_new (L0,t_c_insulin2,p_true,plt,'%+8% RUIS%');
    end

% adding noise
if NoMean==0
data2_new=c_interstitial_insulin_model2_interp1;
%data2_new=data2_new+0.10 * randn(length(data2_new),1);%+8% RUIS
else
data2_new=c_interstitial_insulin_model2;
%data2_new=data2_new+0.10 * randn(length(data2_new),1); %+8% RUIS%
end

% make plots if plt=1
plt=1;

steil_param;
Nparameters=length(p_true);
% End initialisation

% 2-dimensional parameter space
%p = [Ib SICap p2];
%1 known parameters:
p_fix = [Ib p2];
%1 unknown model parameters:
p_init = [SICap]

p_init_copy=p_init;
estimation(1,:)=[-0.5 -0.4 -0.3 -0.2 -0.1 0.1 0.2 0.3 0.4 0.5 ];
estimation1(1,:)=estimation(1,:);

for kk=1:length(p_init)
    ll=0;
    for zz=estimation(1,:)
        p_init=p_init_copy;
        ll=ll+1;

        estimator=find(p_init(kk)==p_true);

```



## D.8.2

### steil\_param.m

```
%%  
% Steil's Model of insulin kinetics.  
%  
%This script initializes all parameters of Steil's Model of insulin  
%kinetics and the time samples of plasma insulin.  
%%  
%  
%History  
%28-July-06, Salvador Almagro Frutos, TU/e  
%29-Jan-04, Natal van Riel, TU/e  
%17-Jun-03, Natal van Riel, TU/e  
%%  
  
%model parameters:  
%Values from: ???????  
Ib = Ib; %[pM] baseline insulin concentration in plasma  
SIcap = SIcap; %[1/min] transendothelial insulin transport parameter  
p2 = p2; %[1/min] total fractional insulin clearance from the  
%interstitial fluid  
  
p_true = [Ib, SIcap, p2];% 2 dimensional parameter space  
  
%Fixed initial conditions  
clear L0;  
L0(1) = 0; % [pM] insulin concentration in interstitium  
  
%Input insulin concentration in plasma [pM]; assumed to be known at  
each  
%simulation time sample from linear interpolation of its measured  
samples  
  
%Time and amplitude samples of plasma insulin:  
%1-> blood glucose data  
t_insulin1 = t_c_insulin1(:,1);  
c_insulin1 = t_c_insulin1(:,2);  
t_c_insulin1(:,1) = t_insulin1';  
t_c_insulin1(:,2)=c_insulin1';  
  
% squared 2-norm of the error-function residuals  
  
a=1; %output weighting factor of plasma glucose concentration (1st  
output)  
  
sigma1=1; %variance of plasma glucose concentration(1st output)  
  
%Plots  
% make plots if plt=1  
if plt==1;  
%Plots
```

```

figure; plot(t_c_insulin1(:,1), t_c_insulin1(:,2), 'b'); hold
%Baseline level:
plot( [t_c_insulin1(1,1) t_c_insulin1(end,1)], [Ib Ib], 'r', 'LineWidth', 2, 'LineStyle', 'dashed', 'Marker', 'none')
axis([0 1.5 0 1.5])
xlabel('Time [min]'); ylabel('Insulin [mU/L]');
title('Insulin concentration over time')
end

```



## D.8.3

### steil\_sim.m

```
function [c_interstitial_insulin]=steil_sim
(L0,t_c_insulin,p,plt,TITLE)

%%%
%Steil's Model of insulin kinetics.
%
%This function makes a simulation of the Steil's Model of insulin
%kinetics using the parameters defined in steil_param.m.
%
%%%
%Function:
%[c_interstitial_insulin]=steil_sim (L0,t_c_insulin1,t_c_insulin2,p,...
%plt,TITLE)
%
%Inputs function:
%L0: Fixed initial conditions,L0(1)= [pM] insulin concentration in
%interstitium.
%t_c_insulin: [pM] [min] Time and amplitude samples matrix of plasma
%insulin 1 > blood glucose data 2 > interstitial glucose data
%p = [S1cap, p2];% 2 dimensional parameter space
%plt: plots are made in this function if plt=1.
%TITLE: set the title-name if plots are made in this function (plt=1).
%
%Outputs function:
%c_interstitial_insulin: [pM] interstitial insulin concentration.
%%%
%
%History
%28-July-06, Salvador Almagro Frutos, TU/e
%29-Jan-04, Natal van Riel, TU/e
%17 Jun 03, Natal van Riel, TU/e
%%%

%model parameters:
%S1cap [1/min] transendothelial insulin transport parameter
%p2 [1/min] total fractional insulin clearance from the
%interstitial fluid

%Differential equations solver: ode15s
ode_options =odeset('ErrorTol',1e-6,'StepTol',1e-12);% parameters 2-end
%%ode_options =odeset('RelTol',1e-9,'AbsTol',1e-16);

[t,L] = ode45(@steil_ode,t_c_insulin(:,1),L0,ode_options,
t_c_insulin,p);

%Output
c_interstitial_insulin=L(:,1); % [pM] interstitial insulin concentration

% make plots if plt=1
```

```

if plt==1
%Plots
figure (333);
Ib=p(1);
subplot (221);plot (t_c_insulin(:,1),t_c_insulin(:,2),'r--'),
'LineWidth',2);
hold on;
%Baseline level:
plot( [t_c_insulin(1) t_c_insulin(end)], [Ib Ib], 'b',
'LineWidth',1.5)
ylabel('Insulin (mU/L)');
xlabel('Time (min)');
Title('Insulin (mU/L) vs Time (min)');

%figure
subplot(222); plot(t_c_insulin(:,1), c_interstitial_insulin,
'g--','LineWidth',2)
xlabel('Time (min)'); ylabel('Insulin (mU/L)');
Title(TITLE);

end

```

## D.8.4

### steil\_ode.m

```
function dLout = steil_ode(t,Lin,t_c_insulin,p)

%%
%STEIL_ODE ODE's of STEIL'S Model of insulin kinetics.
%
%This function sets STEIL_ODE ODE's of STEIL'S Model of insulin
%kinetics using the parameters defined in steil_param.m.
%%
%
%Function:
%dLout = steil_ode(t,Lin,t_c_insulin,p).
%
%Inputs function:
%Lin: state values at previous time sample L(k-1) = [X(k-1)]
%t_c_insulin: c_insulin(k) (input signal at sample k) OR matrix
%t_c_insulin
%p: = [SIcap, p2];% 2 dimensional parameter space
%
%Outputs function:
%dLout: new state derivatives dL(k) = [dX(k);]
%
%%
%
%History
%28-July-06, Salvador Almagro Frutos, TU/e
%29-Jan-04, Natal van Riel, TU/e
%17-Jun-03, Natal van Riel, TU/e
%%

% defining the row were each state in statevector Lin is present
idx = 1; %interstitial insulin concentration [pM]

% model parameters:
Ib = p(1); %[pM] baseline insulin concentration in plasma
SIcap = p(2); %[1/min] transendothelial insulin transport parameter
p2 = p(3); %[1/min] total fractional insulin clearance from the
%interstitial fluid

%calculate c_insulin by interpolation of t_c_insulin
u = interp1(t_c_insulin(:,1),t_c_insulin(:,2), t);

%ode's

dX = SIcap/1e3*(u-Ib)^2-p2*Lin(idx);

dLout = [dX];
```

## D.8.5

### gluc\_omm\_mls\_steil.m

```
function [p_model,L0_model,c_interstitial_insulin_model,...
resnorm,residual,varp,stdp]=gluc_omm_mls_steil...
(data1,L0,t_c_insulin1,a,sigma1,p_fix,...
p_init,Nparameters,plt)

%%
%STEIL_MM_MLS Maximum Least Squares Estimation of Steil's Model of
%insulin kinetics
%
%%
%This function estimates the parameters using Maximum Least Squares
%Estimation of Steil's Model of insulin kinetics using the
%parameters defined in steil_param.m.
%%
%Function:
%[p_model,L0_model,c_interstitial_insulin_model,...
%resnorm,varp,stdp]=gluc_omm_mls_steil...
%(data1,L0,t_c_insulin1,p_fix,p_init,Nparameters,plt)
%
%Inputs function:
%data1: data of interstitial insulin [pM]
%L0: Fixed initial conditions,L0(1)= [pM] insulin concentration in
%interstitium.
%t_c_insulin: [pM] [min] Time and amplitude samples matrix of plasma
%insulin 1-> blood glucose data
%p: = [S1cap, p2];% 2-dimensional parameter space
%p_fix: parameter space which is fixed.
%p_init: initialisation of parameter space which will be estimated.
%sampleinterval [min] of data 2.
%Nparameters: number of dimensional parameter space p.
%plt: plots are made in this function if plt=1.
%
%Outputs function:
%p_model: [S1cap,p2];% 2 dimensional parameter space
%c_interstitial_insulin_model: [pM] interstitial insulin concentration.
%resnorm: squared 2-norm of the error function residual.
%residual: the value of the residual of the estimation algorithm.
%varp: variance
%stdp: The standard deviation is the square root of the variance.
%%
%
%History
%28-July 06, Salvador Almagro Fuentes, TU/e
%29-Jan-04, Natal van Riel, TU/e
%17 Jun 03, Natal van Riel, TU/e
%%

% lower (lb) and upper (ub) bounds, so that the solution of the
estimated
% parameters is always in the range lb <= parameter <= ub.
```

```

lb = [];%0*ones(size(p_init));%[0 0 0 0];
ub = [];%ones(size(p_init));%[];

% provides the function specific details for the options values for
% lsqnonlin
options =optimset('Display','none','TolFun', 1e-10,... %'iter'
default:1e-4
'TolX',1e-20,... %default: 1e-4
'MaximumEvaluations', [800],... %800 default:
'MaximumFunctionEvaluations',... %default: on
'MinimumStepSize',...%default: on
'MinSearchDepth',...%default: 1);
%'Jacobian','on');

%LSQNONLIN: objective function should return the model error
%p_estimated: estimated parameters
%resnorm: squared 2-norm of the residual
%residual: returns the vector of the residuals
%jacobian: returns the Jacobian of fun at the solution x.

[p_estimated,resnorm,residual,exitflag,output,lambda,jacobian]...
=lsqnonlin(@obj_fn_steil,p_init,lb,ub,options,p_fix,L0,datal,...
t_c_insulin1,a,sigma1,Nparameters);

if exitflag==0
STOP=1;
end

%Accuracy:
%lsqnonlin returns the jacobian as a sparse matrix
varp = resnorm*inv(jacobian'*jacobian)/length(t_c_insulin1(:,1));%
variance
stdp = sqrt(diag(varp)); %The standard deviation is the square root
%of the variance

p_model = [p_fix(1) p_estimated(1) p_fix(2)];

L0_model = [L0(1)];

% make plots with new 2 dimensional parameter space if plt=1
[c_interstitial_insulin_model]= steil_sim (L0,...
t_c_insulin1,p_model,plt,' ');

```

## D.8.6

### obj\_fn\_Steil.m

```
function error = obj_fn_Steil(p_var, p_fix, L0, data,t_c_insulin1...
    ,a,sigma1,Nparameters)

%%%
%Objective function Maximum Least Squares Estimation of Steil's
%Model of insulin kinetics.
%
%%%
%This function is used as objective function for LSQNONLIN.
%%*
%Function:
%e = obj_fn_steil(p_var, p_fix, L0, data,t_c_insulin1,...
% Nparameters)
%
%
%Inputs function:
%p_var: parameter space which will be estimated
%p_fix: parameter space which is fixed.
%L0: Fixed initial conditions, L0(1)- [pM] insulin concentration in ...
%interstitium.
%data: data of interstitial insulin [pM].
%t_c_insulin: [pM] [min] Time and amplitude samples matrix of plasma
%insulin.
%a: output weighting factor of 1st output.
%sigma1: variance of 1st output.
%Nparameters: number of dimensional parameter space p.
%estimator: defines the parameter which is used in the model to model
%adjustment identification.
%
%
%Outputs function:
%error: minimization variable of MLS (scaled error)
%%*
%
%History
%28 July-06, Salvador Almadre Frutos, TU/e
%29 Jan-04, Natal van Riel, TU/e
%17 Jun 03, Natal van Riel, TU/e
%
p_estimating=[p_fix(1) p_var(1) p_fix(2)];

%estimating 2-dimensional parameter space
%p_true = [Ib,SIcap,p2];

%Simulating Steil model of insulin kinetics using the estimating
%2-dimensional parameter space and the interpolated insulin
concentration
%samples for data1.

plt=0; % make NO plots
[c_interstitial_insulin_estimating]=...
```

```

steil_sim(L0,t_c_insulin1, p_estimating,0,...
' ');

error1 = c_interstitial_insulin_estimating-data1;

error=error1;

p_var

if plt==1
N=length(t_c_insulin1(:,1));
figure(100)
plot(1:N,c_interstitial_insulin_estimating,'-',1:N,data1,' ');
xlabel('Time (min)');
ylabel('Interstitial insulin (mU/L)');
Title({'Interstitial insulin (mU/L) vs Time (min)';...
'Estimated values: -; Data: '});
drawnow;pause(.3);
end

```