

**MASTER**

**Deploying, analysing and configuring wireless sensor networks**

Ahsmann, J.J.

*Award date:*  
2013

[Link to publication](#)

**Disclaimer**

This document contains a student thesis (bachelor's or master's), as authored by a student at Eindhoven University of Technology. Student theses are made available in the TU/e repository upon obtaining the required degree. The grade received is not published on the document as presented in the repository. The required complexity or quality of research of student theses may vary by program, and the required minimum study period may vary in duration.

**General rights**

Copyright and moral rights for the publications made accessible in the public portal are retained by the authors and/or other copyright owners and it is a condition of accessing publications that users recognise and abide by the legal requirements associated with these rights.

- Users may download and print one copy of any publication from the public portal for the purpose of private study or research.
- You may not further distribute the material or use it for any profit-making activity or commercial gain

# Deploying, analysing and configuring wireless sensor networks

---

Written by: Joris Ahsmann  
Date: 1 July 2013  
Student at: Technische Universiteit Eindhoven(TUe)  
Tutor TU/e: Twan Basten

Location: Cork Institute of Technology  
Department: Nimbus Centre  
Tutor CIT: Alan McGibney

## Table of contents

|  |    |
|--|----|
| Table of contents.....   | 2  |
| 1 Preface .....  | 3  |
| 2 Introduction .....   | 4  |
| 2.1 General.....   | 4  |
| 2.2 Research Goals .....   | 4  |
| 2.3 Thesis Outline:.....   | 5  |
| 3 Current State of Research in Wireless Sensor Networks .....                  | 6  |
| 3.1 Wireless Sensor Network Architecture.....                                  | 6  |
| 3.2 The Routing .....  | 8  |
| 3.3 The planning.....  | 11 |
| 3.4 Quality of Service Support.....  | 12 |
| 3.5 Nimbus Wireless Sensor Network Test-bed .....                              | 13 |
| 3.6 The wireless deployment tool .....   | 17 |
| 3.7 Conclusion .....   | 19 |
| 4 How to analyse and configure a wireless sensor network.....                  | 20 |
| 4.1 Analysing a network .....  | 20 |
| 4.2 Configuring the network.....   | 30 |
| 4.3 Determining the required configuration .....                               | 37 |
| 4.4 Verification of the analysis and configurations on real deployment's ..... | 42 |
| 4.5 The analysis tool .....  | 51 |
| 4.6 Conclusion .....   | 57 |
| 5 Linking the Deployment to the Design .....                                   | 59 |
| 5.1 The multi wall model: .....  | 59 |
| 5.2 The ray tracing model.....   | 61 |
| 5.3 Analysis based on site survey data .....                                   | 63 |
| 5.4 Ray tracing model adjustment based on the data from real deployments.....  | 68 |
| 5.5 Conclusion .....   | 71 |
| 6 Conclusion.....  | 74 |
| 7 Bibliography .....   | 77 |

## 1 Preface

This thesis marks the end of my study Embedded Systems at the Technische Universiteit Eindhoven. For the last nine months I've been welcomed by the nimbus Centre which is part of the Cork Institute of technology to conduct my research for this thesis. I have found Nimbus a pleasant place to work thanks to all the people who work here.

During these 9 months I've been doing research regarding the behaviour of wireless sensor network. In this research I had the opportunity to use a within Nimbus developed test bed. This gave me opportunity to analyse the behaviour based on a real deployment. For which I want to thank Davide Pusceddu, who has been helping me understanding the test bed during these nine months. Next to that I would like to thank Alan McGibney, who has my supervisor and the one who gave me guidance and was always willing to help me out in case of issues.

At the end I would like to give special thanks to Twan Basten, who was always available for feedback and commends on my work. I found the feedback I got from him very detailed and clear and helped me a lot during this period.

Joris Ahsmann

## 2 Introduction

### 2.1 General

Advances in modern day technology have enabled engineers to develop small, low cost wireless sensor devices that can communicate with each other and form large networks of sensing and/or actuating devices. These networks are now being used to obtain dense environmental data for applications such as habitat monitoring [1], flood warning [2] or fire detection in for example forests [3] or tunnels and provide engineers the ability to move from beyond basic centralized sensing and controlling of the environment to large scale sensing and distributed control systems.

The development of wireless sensor networks (WSN) has many different aspects to be considered such as sensor calibration, data reliability and power management. As the scale of deployments has increased significantly in recent years one of the key focal points of research has been the challenges related to the deployment and configuration of WSN. A WSN typically consists of small, low cost, wireless battery powered nodes. The objective is to deploy the nodes in such a way that the network matches the required sensing criteria, maintaining a reliable communications link and maximising the lifetime of the network all at minimal cost. To achieve all these goals is a non-trivial task even for the experienced designer.

### 2.2 Research Goals

WSN are deployed for many different environments and purposes all having their own challenges. Due to the dynamic nature of buildings and the complexity of radio propagation within them they pose a significant challenge when it comes to planning and design of wireless applications. The biggest challenge associated with these networks is ensuring reliable connectivity between the nodes while maintaining a reasonable lifetime. Walls, furniture and people all influence how a wireless signal propagates through the building and this can have an adverse effect on network performance. Even if the influence of a building is taken into account at design time, the dynamic nature of a building can often lead to unpredictable behaviour of the WSN during its lifetime. Once a sensor network is deployed and operating it generally collects all the sensed data at a centralized point for processing within business applications. Analysing how data travels through the network and ensuring it operates as expected can be a difficult task due to the large amount of data and dynamics of the network behaviour.

The research presented in this thesis will focus on the development of tools and methodologies to analyse and configure WSN in buildings and it investigates how these tools and the information gleaned from them can be used to improve the quality of a site specific deployment. More specifically the research will investigate the following:

1. What data can be extracted from a live network and how can it be used to analyse and verify the performance of the WSN post-deployment
2. How can the network be configured/re-configured to ensure requirements are met while maintaining a maximum lifetime
3. How can the extracted information/QoS metrics be feed back to the design phase to improve on the site specific deployment.

### 2.3 Thesis Outline:

First Section 3 will focus on the state of the art in wireless sensor networks, the focus will be on the components in wireless sensor networks, routing protocols and quality of service provisioning. After this the test bed is analysed. What components are used and what is implemented in this test bed. Section 3.5 will present the analysis of the WSN test bed. This includes a description of the different components as nodes, routing protocol and the deployment tool.

Section 4 will identify what metrics will the test bed produce for analysis and how do those metrics reflect the quality of the network. Once the analyses of the network can be made the information is used for quality of service provisioning is presented. This research resulted in the development of an analysis tool, and analysis descriptions for the physical, link and transport layers in the network. Next to that a QoS provisioning method is introduced. This tool is used to visualize the status of the network and all the data it produces.

Section 5 will focus on how real time information from the network can be feed back to the design step and potentially be used to identify issues within the network and ultimately improve the quality of the initial design.

### 3 Current State of Research in Wireless Sensor Networks

Research in WSN started in the US military. One of the first WSN was developed by the American army in the sixties which was used to detect Soviet submarines [4]. The network consisted of submerged acoustic sensors which were deployed over the Pacific and Atlantic oceans. For a long time WSN has only been a subject for military use and research. This is mainly due to its cost. However recent advances in technology made wireless systems cheaper and more energy efficient. This drove the proliferation of WSN as they became affordable for commercial use, which intensified the research and applications of wireless sensor networks.

When using WSN different challenges have to be faced. All of those challenges are related to the resource constraints on the sensor nodes. Since all nodes are wireless they should have all resources, such as power, memory, computational power and communication capabilities on board. Therefore the first challenge is the selection of which nodes should be used for the application; what should a node be capable of; how should those nodes communicate; and how long should they last without changing or recharging the batteries. After the choice of nodes is made the next challenge is how to create a network. How should the nodes route their data through the network to form a fully connected network. This is strongly related to the challenge of deployment planning in WSN. This involves addressing how to position the nodes in such a way that they are able to form a network which is able to fulfil its task. Once the network is deployed the next challenge is how to configure the network in such a way that it meets its requirements which are given by the quality of service (QoS).

The topics of interest are listed here and the current state of the research will be discussed in this section.

- The wireless sensor network architecture
- Routing packets through the network
- Planning of the network
- Quality of Service support

On the first three points, the network architecture, routing and planning of the network, research is more or less crystallized. The general picture is clear and different types are defined. However the quality of service support for wireless sensor network is still an open ended research topic. Several research works have been published over the last few years but they all focus on their own specific types of quality of service. I couldn't find a common notion on the definition of quality of service for WSN and assumes that still does not exist yet.

#### 3.1 Wireless Sensor Network Architecture

A wireless sensor network typically consists of three types of components, sensor nodes, sinks and relay nodes. The sensor nodes are responsible for the sensing and actuation. Relay nodes can be added as an intermediate to create a fully connected network if sensor nodes are unable to reach the sink. A sink collects all the data from the sensor nodes for centralized processing and/or storage. This is illustrated in Figure 1

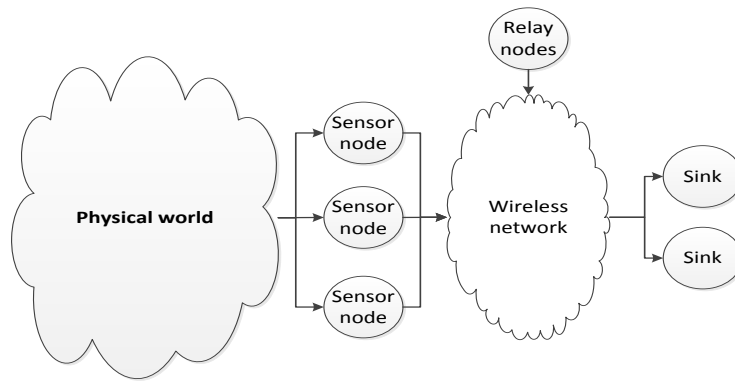

**Figure 1: Wireless Sensor Network Architecture**

Typically radio signals are used to connect the nodes with each other. Commonly used radio communication protocols for low power networks are ZigBee [5], WirelessHART [6], 6LowPAN [7]. These protocols work on the 2.4GHz band and are all based on the 802.15.4 standard, a standard for low power wireless communication. The most wireless sensor networks used today are based on one of those protocols however all industrial, scientific and medical bands (ISM) can be used for communication. The frequencies of those bands are

| Industrial, scientific and medical bands |
|--|
| 6765–6795 kHz                            |
| 26,957–27,283 kHz                        |
| 40.66–40.70 MHz                          |
| 433.05–434.79 MHz                        |
| 902–928 MHz                              |
| 2400–2500 MHz                            |
| 5725–5875 MHz                            |
| 24–24.25 GHz                             |
| 61–61.5 GHz                              |
| 122–123 GHz                              |
| 244–246 GHz                              |

On top of the physical connectivity the wireless sensor network often inherits a basic version of the IPv6 protocol stack such as 6LowPAN. Using the IPv6 stack makes the integration of the system with the internet straight forward and also makes the support which can be used for the IPv6 stack available for maintaining the network.

### 3.1.1 Nodes

A node is the component that captures sensed data from the environment and sends this data to a sink and typically consists of the following four components:

- Sensor(s)
- Controller
- Communication device
- Battery

The sensors are form the connections between the physical world and the wireless sensor network. All different sized sensors exist, for example temperature, light or humidity sensors. The controller is



the heart of the node; this normally is a small controller that is used to perform aggregation on the data and controls the sensors and the communication of the node. The communication device is the antenna for the communication often combined with a controller that is used to control the antenna. And the battery is the energy source of the node. This could vary from some small to large batteries. This depends on the required lifetime and application of the network.

Sensors can operate in three modes. The first mode is that the sensor periodically sends its sensor data to a sink where it will be processed; this is called periodic sensing. The second mode is event-based where the sensor is programmed only to send data when a certain event occurs, for example, when a sensor reading exceeds a pre-defined threshold value. And the third option is a query mode. In this mode a sensor will not send data out of its own but will only respond to query's send to it from other nodes or applications.

The node lifetime is mainly determined by the activity of the radio chip and the battery. To increase the lifetime the radio chip is periodically turned on to see if other nodes want to send data to it, or to transmit its own packets. This is done in a synchronized manner so that when a node transmits a packet the other nodes are able to listen. If there is no more communication on the link all nodes turn off their radio chip and turn on again in the next period. In [8] this mechanism known as the nodes duty cycle is described. The duty cycle can have a great influence on the latency and energy consumption of the packets and nodes.

### 3.1.2 Sinks

The purpose of a sink is to collect sensor data and process it or send it to another location where it will be processed and/or stored. What it does with the data depends on the application which requires the data.

Due to the computational demand a sink is normally connected to a power source and therefore has no or less power constraints than a node. With this in mind, in many cases the sink can not only be responsible for the gathering of the data but also for maintaining and organizing the sensor network topology. The routes that the sensors should use can be determined at the sink as it has the capability to analyse the network status and create routing tables based on the observed network activity. This is however only done for relatively small networks, otherwise the induced overhead on the network to send all data to the sink required to create the routes is too large. In these cases it is better to locally determine the routes .

### 3.1.3 Relay nodes

A sensor should be placed at the location where it can sense the highest quality of data. Due to walls, furniture, people and the size of the building sensors could be too far apart for a single sink to be placed within range of all of the sensors. To solve this mesh routing can be used. When a network gets fragmented, extra communication nodes can be deployed to cover the entire area; these nodes are called relay nodes.

## 3.2 The Routing

The quality of the network is highly related to the routes the network uses. Typically the network is able to select different routes to route the data through the network. The routing protocol is responsible for selecting the routes in the network and determining the routes in the networks involves selecting for each node to which other node it should send its data. In a mesh networks

forming the routes in such a way that all nodes are connected can be a hard task. Many different options exist and finding the optimal topology can be difficult.

WSN are used for many different purposes and can be in various sizes, each purpose and size will have its own characteristics and requirements, and can have all other ways to route data through the network. When routing data through a network, different quality metrics for the used topology exists. A topology should in the first place be able to let all the nodes in the network route their data through the network to, in the case of WSN, a sink. Next to this several optimization goals can be distinguished. The main options are lifetime optimization, redundancy, latency minimization and reliability optimization [9].

Lifetime optimization involves creating a topology in which the lifetime of the network is optimized. Usually the lifetime of the network is defined as the lifetime of the node with the shortest lifetime. In order to optimize the lifetime of the network the topology should be balanced. This means that the load on all nodes should be as equal as possible. A completely balanced network is however infeasible [1]. All nodes will send their data back to a sink, when they cannot reach the sink directly multi-hop routing is used. This results in the nodes closer the sink always having a higher load than nodes on the edge of the network. Lifetime optimized routing protocols try to balance the load as much as possible while maintaining a network in which all nodes are connected.

Redundant routing is an approach used to optimise the reliability of the network. This type of routing involves sending the data over multiple links. This way when the data packet is dropped on one link, the other path might still succeed which causes probability that data is lost is reduced. The challenge in this type of routing is how to ensure multiple paths for all nodes which are also reliable and have a minimal impact on the network.

Latency minimisation routing tries to minimise the maximum latency of all nodes. The simplest example of latency aware routing is to minimize the number of hops. But also more complex latency aware routing protocols exists that includes for example the duty cycle of the nodes.

The last routing optimisation option is the reliability. This involves optimising the reliability of the path from a node to the sink. The reliability can be measured as the probability that a packet is successfully propagated through the network. Therefore when creating a network topology, the links over which the packets are routed, should be as good as possible. Those quality metrics should be used when creating a topology. Creating a topology can be done several different ways. The most common ones are listed here.

- Static routing
- Centralized routing
- Decentralized routing

Those 3 listed types will be discussed in this section.

### 3.2.1 Static Routing

Static routing means that all routes in the network will be determined pre-deployment. No online analysis of the network is done. This type of routing is common in small networks where the environment is static. An example of a commonly used static routing method is the star topology as in Figure 2.

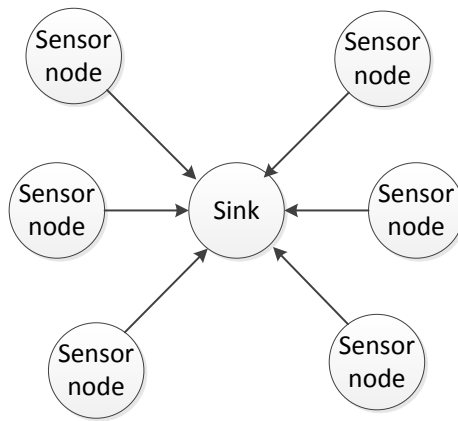

Figure 2: Star Topology

All nodes will send their data directly to the sink, and must therefore be in the communications range of the sink. Larger, multi hop static routing is also possible and normally only used in small networks because all routes have to be determined by hand pre-deployment.

### 3.2.2 Centralised routing

Centralised routing means that on a central point, normally the sink the routes in the network are determined. All nodes will check which nodes are within its communication range, and what the qualities of the links are. This data is then sent to the sink which then determines which link the nodes should use to send its data.

The advantage of using centralised routing is that the routes of the nodes do not have to be pre-determined. Also the network is able to respond to changes in the network. Normally the nodes will periodically send status updates to the sink. Based on those status updates the sink can decide to change the used topology. This way the network is able to respond to changes in the network.

The advantage of doing this in a centralised way is that at the central point an overview of the complete network is available. Thus when creating a topology the impact on each node can be considered and a global optimum can be determined. However the downside of creating a network in a centralised way is that all nodes will have to send status updates to a centralized point. For small networks this not a problem. However WSN could scale up to thousands of sensors. In these situations created extra load might overload the network, reducing its lifetime and consuming the available bandwidth.

### 3.2.3 Decentralised Routing

When using decentralised routing nodes or groups of nodes, will define their routes based on local knowledge. Using decentralised routing will give nodes the ability to independently define their routes using the information of their neighbours. The required information to select a route depends on what type of routing is used. Different routing protocols will rely on different types of metrics to form its route decision.

The major advantage of this method is that nodes are able to locally define their own route which means that the network is able to maintain its own topology without the need of a central node or sink to gather all the data and define the routes. The disadvantage of this approach is that there is no global knowledge of the topology this might lead to inefficient topologies which from local

perspective is the best possible. Also this method can create a higher computational load on the nodes. For large networks this type of routing is preferred since the added load on the nodes resources is a static load for each node whereas when using the centralized routing the load on the nodes increases by the size of network.

### 3.3 The planning

A WSN has two major functions, sensing and communicating. When deploying a WSN, those two functions are the most important things to consider in order to ensure a network is capable of meeting application requirements. Next to these functions there is also a set of secondary requirements. The secondary requirements focus more on the quality of the deployed network. Both are discussed in this section.

#### 3.3.1 Primary requirements

##### 3.3.1.1 Coverage

Each sensor type has different constraints for covering an area. For example, one temperature sensor could be sufficient to cover a room, where maybe multiple sensors per room are required to sense movements. The properties of all sensors should be used to create a network which covers all the requirements of the sensor network. Coverage involves the placement of sensors in such a way that all the required sensing data for the application can be sensed. To design a sensor network which has full coverage with the minimum number of sensors is often optimally solvable in 2D but becomes NP-Hard in 3D [10]. NP stands for non-deterministically polynomial and implies that typically no optimal solution can be computed based on the current computing power and algorithm knowledge within reasonable time. Therefore most application designers create a 2D abstraction of their environment instead of using a 3D version.

##### 3.3.1.2 Connectivity

The connectivity problem involves making sure that all nodes are able to send their data to a centralised point, normally the sink. When the coverage problem is solved in a 2 dimensional abstraction, a set of sensing nodes are placed on a 2 dimensional plane. Those nodes should then try to form a network and often the sensor nodes alone form a fragmented network. Therefore relay nodes should be added. Since adding relay nodes involves an increase of the price, the number of added relay nodes should be kept to a minimum. In [11] a Steiner Minimum tree with minimum number of Steiner points and bounded edge length (SMT-MSP) is used to solve this problem, and this problem is proven to be NP-Hard. Therefore computing the optimal solution is not tractable and other non-optimal solutions will have to be used.

#### 3.3.2 Secondary requirements

Along with the primary requirements connectivity and coverage, there is also a set of secondary requirements. Those requirements are used to cover the price and quality of the network and should be considered when creating a deployment. The requirements are:

- Lifetime
- Throughput
- Latency
- Cost

### **3.3.2.1 Lifetime**

Lifetime involves the duration of the network that it is capable of operating. Since sensors and relay nodes are battery powered their lifetime strongly depends on the amount of energy required for operation. When the network is designed with a minimum number of sensor and relay nodes the death of a single node could cause all nodes relying on that node to become disconnected. Therefore the system should try to balance the power consumption of all nodes in the network in order to maximize the lifetime. Balancing the power consumption involves minimizing the distance between nodes to be able to reduce the transmission power. This is because communication is a key energy consumer as the radio signal power in the network drops off with  $d^4$ , where  $d$  is the distance between the transmitter and the receiver [11]. When balancing the distance between nodes the energy consumption per transmitted packet is balanced, however a wireless sensor network often is a multi-hop network. So also the number of packets a node needs to send should be balanced. When there is a single node forwarding the data of multiple nodes, its battery will deplete much faster resulting in a shorter lifetime of the network. Due to this multi hop property of a mesh topology the nodes close to the sink will deplete their batteries quicker than nodes at the borders of the network. This problem can sometimes be reduced by actively measuring the remaining lifetime of the nodes and to spare the nodes with the lowest lifetime.

### **3.3.2.2 Throughput**

Throughput involves the amount of data a node can transmit per time unit. When the network scales up, the amount of data it produces increases. Because of the multi-hop property the nodes close to the sink will have to forward more data when the size of the network increases. When the network is designed it should be made sure that no nodes are overloaded. Thus it should be assured that the bandwidth is sufficient for all nodes' demands. When determining the throughput it is important to consider that it is impossible for multiple nodes that are within range of each other to transmit data at the same time since then their signals will interfere with each other. Thus when checking whether the bandwidth is sufficient the load of the nodes within range of each other should be combined.

### **3.3.2.3 Latency**

Latency involves the time it takes to transmit a packet from a node to the sink. When the application contains latency constraints the network should be able to meet these constraints. The latency is strongly related to the number of hops a packet takes from a node to the sink. When this number is too large, the distance between the nodes should be increased to lower the number of required hops from the node to the sink. This requirement is fully dependent on the application requesting the data.

### **3.3.2.4 Cost**

Cost involves the price of the network as a whole, as each node (sensor, relay, sink) will cost money, the number of nodes required for the network should be kept to the minimum. The optimisation goal for cost can be described as follows. Given the requirements of the sensing network, create a network with the minimum number of nodes while satisfying the requirements.

## **3.4 Quality of Service Support**

Defining quality of service (QoS) is always an important aspect in designing a system. The QoS defines requirements for the system and heavily relies on the applications using the system. Based on those requirements the system should determine how it utilises its resources. QoS frameworks for

traditional networks have existed already for years; however WSN are different from traditional networks due to the strict resource constraints on the nodes. That difference also requires different methods to define the required QoS. A new extended QoS definition method will have to be applied on WSN. In [12] a survey is given on what options there are to specify QoS requirements for WSN. This survey shows that due to the wide variety it is hard to create one basic QoS framework. Currently QoS support for wireless sensor networks is one of the open research topics. Different models for different types of QoS are developed, but there is not yet a common notion of how to handle QoS support in WSN. This also depends on the application; currently different QoS support frameworks are developed to support different types of application.

What the most QoS support methods have in common is that the required quality of service is specified in two layers. The Application specific layer and network specific layer [13]. The application QoS requirements will specify the application needs in terms of for example coverage or sensor accuracy. The network related QoS involves the metrics which are often known from traditional networks. Metrics as throughput, latency, lifetime and reliability are the most important ones and are often derived based on the application QoS.

The challenge when creating a QoS aware WSN is that the metrics used are often conflicting, for example reliability and lifetime. In [14] a method is introduced that tries to optimise the lifetime of the network by periodically turning redundant nodes off, and use energy aware routing protocols. This comes at the cost of a lower reliability of the network. However this cost is kept to a minimum by measuring the remaining quality and when this becomes too low the nodes will not be turned off or other routes are used.

### **3.5 Nimbus Wireless Sensor Network Test-bed**

The QoS methodology and experiments presented in this thesis will utilise the Nimbus WSN test bed; in this section the components of the test bed is introduced. Firstly all network components, nodes, sink and used data packets will be described. After this the developed wireless sensor network deployment tool is introduced.

#### **3.5.1 The network components**

The Nimbus WSN is composed of the TelosB sensing platform developed by Crossbow [15]. These devices are deployed with the open source TinyOS operating system. For the sink a mini computer is used. And the network itself is a periodic-based sensing network. All components used in the test bed, and the communication protocols are discussed in the following subsection.

##### **3.5.1.1 Sensor Nodes**

The TelosB node has IEEE802.15.4 communication capabilities with an on-board antenna and contains a "TI MSP430" microcontroller and a set of on board sensors including light, temperature, humidity and supply voltage sensors. The power supply of those nodes consists out of two AA batteries. The node is shown in Figure 3.



Figure 4 - TelosB Sensor Node [15]

In the test bed sensor nodes periodically send two types of packets, sensor packets and statistics packets. The sensor packets contain information about the sensor readings whereas the statistics packet contains information about the behaviour of the sensor for example the address of its parent and the quality of the used link. The periods of the packets is configurable and can vary from once per couple of seconds to once per hour. The used period will be determined by the application requesting the data.

### 3.5.1.2 The sink

The sink consists of a node, just like all the others, combined with an embedded PC connected to the LAN and running a stripped version of Linux. The node will be used to receive the data from the WSN, and the computer to execute all the sink tasks. The responsibility of the sink is to send all the received data to the next layer in the system. This can either be a database or an application.



Figure 5 A sink

As well as sending the data from the nodes to an application, a sink can also be used to debug the network, and reconfigure the nodes. The sink will be informed by the nodes about their status and routes; In the Nimbus test bed nodes send status reports regarding their links and topology back to the sink. Since indoors the networks or node clusters do not tend to be as large as for example forest fire detection and can therefore handle this extra load. This information can be used to debug and analyse the network. In terms of reconfiguration the sink can be used for example to change the sensing period or the communication channel being used.

### 3.5.1.3 The Application Layer

The application layer has as input the data from a sink; this can be either a single sink or multiple sinks. At the moment this layer will parse the packets and store the data in a database for later use. The middleware layer could also be used to develop and execute applications which rely on the data from the WSN. For the purpose of this document, storing the data can be seen as the application. The relationships between all components are illustrated in Figure 6:

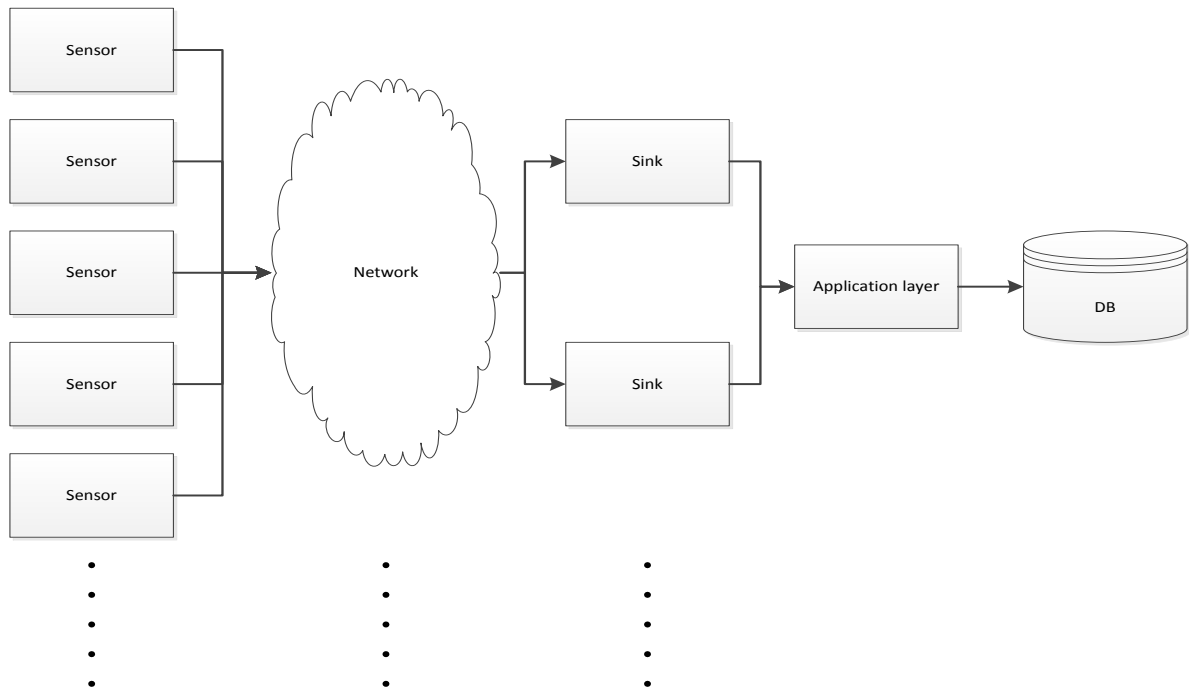

Figure 6: Full system

### 3.5.1.4 Hydro Routing Protocol

Since the routing protocol has a great influence on the behaviour of the routing proctor does this from an crucial element for the network. In the test-bed a routing protocol called Hydro is used. Hydro [16] is a decentralized routing protocol used by the WSN to determine the routes in the network. This means that each node itself determines which node it chooses as its parent. Nodes periodically send data to each other that summarises the status of their connection to the sink. The ETX metric is used for this. ETX stands for the estimated number of transmission to successfully transmit a packet and is a link quality indicator.

If a node A connects to the sink it will actively measure its ETX value to the sink. When another node B asks what the status of that node's connection is it will send the ETX value to the other node. Node B could receive ETX values of multiple nodes; in that case it will try to connect to one with the lowest value.

Node B will also measure the ETX value of the link between itself and its parent. But now when a node asks for the status of its link it will add its own ETX value to the value of its parent and send that to nodes asking for it. In this way, the ETX values cumulatively add up, and when the number of links to be traversed to the sink becomes larger the ETX values will also be larger. This is because the smallest ETX value is 1.

A node will always try to connect to the node which has the lowest ETX value. In that way, a node tries to use the least amount of links, and tries to connect to the strong links, since the weak links will have a higher ETX value. However this works for relatively small networks. For example when a rout from a node contains 10 hops and all the nodes will have an ETX of 1.1 the cumulative value will be 11, which equals a route containing 11 hops with an ETX value of 1. In such a case the routing protocol is unable to distinguish the quality of the route with its length. The simplicity of this protocol



allows nodes do determine their own routes, however since there is no global notion of the network those routes might not lead the optimal routes of the network.

### 3.5.1.5 *Nimbus WSN Packet Types*

In the Nimbus WSN, two types of packets are used, Sensor packets and Statistics packets. The Sensor packets give information about the readings of the sensors and contain some additional information about the status of the links. The status of the links is measured by the radio chip on the node. This radio chip measures the received signal strength indicator (RSSI), and the link quality indicator (LQI), values of incoming signals. A link will be measured two ways, from the node to its parent, the route which the sensor data will take and thus the most important one for the application point of view and from the parent to the node. Since data flows both directions the link can also be measured both directions.

Next to the link status the nodes also keep counters to be able to monitor the different activities of the nodes. Those counters involve the number of forwarded packets, number of packets inserted in the network, number of routing protocol messages to name a few.

The following lists show the different data fields in the different packets.

The sensor packets:

- Temperature
- Humidity
- Supply voltage of the node
- Light intensity
- The worst measured RSSI on the link between the parent and the node in the last sensing period
- The worst measured LQI on the link between the parent and the node in the last sensing period
- Address of the parent
- The worst measured RSSI of all connected children in the last sensing period
- The worst LQI of all connected children in the last sensing period
- Address of the child of which the RSSI and LQI measurement is transmitted

All mentioned data fields, except the parent, have an additional field associated with it to indicate whether the reading is valid. So when a sensor packet is received, it is not certain that all the data it contains is useful. For example when a node does not have any connected children, then there will be no valid reading of the RSSI/LQI value between the node and its children, or when there was no communication between the parent and the node, there is no RSSI/LQI reading of this link.

The statistics packets contain a set of counters indicating the behaviour of the node. The data in the statistics packets contains:

- Number of IP packets sent. This is the number packets the node injected into the network
- Number of IP packets forwarded. The number of packets it relayed for other nodes
- Number of received packets dropped due to communication errors (checksum errors)
- Number of packets created by the node which are dropped due to a full queue
- Number of forwarded packets dropped due to a full queue
- Total number of received fragmented packets. When a packet exceeds a data limit, it will be transmitted in multiple packets. This is called fragmentation.
- Total number of fragmented packets dropped. When a packet is fragmented, and not all packets are received the ones that are received are dropped, due to incompleteness.

- Number of UDP datagrams delivered to the node. UDP packets contain configuration commands from the sink to the node.
- Number of router solicitations received. When a node wants another node to relay its packets a router solicitation is sent. Thus the number of received router solicitations is the number of times a node wants to use this node as its parent.
- Router solicitations transmitted.
- Router advertisement received. When a node asks all nodes in the environment to send back their routing information, it transmits a router advertisement.
- Router advertisement transmitted. When a node wants to build its route, it requests its neighbours for their routing information. This is called a router advertisement.
- Total packets received
- The address of the parent node
- Parent ETX. The average number of transmissions to successfully transmit a packet to the next hop.

All data available for analysing the WSN comes from these two packet types, from specific link quality metrics such as RSSI, LQI or ETX to the sensor data and counters for the different packet types. Using these metrics can give a good insight into what is going on in the network. However a metric that is missing here, which is often used to verify the requirements of a network is a timestamp. The network does not have a notion of time and can therefore not measure what the latency of packets is. This means that the actual time of the measurement remains unknown.

### 3.6 The wireless deployment tool

As described in 3.3 designing a WSN is normally done in two stages. The first stage is to determine the locations of the sensors. Since a 2 dimensional simplification of the problem can be solved optimally, the focus for the deployment tool is on the second stage, connectivity, quality and cost of the network. When all sensor locations are known, the complete network should be designed. The connectivity problem itself is already proven to be NP-hard. Adding the secondary constraints makes this problem only harder. To solve this optimisation problem in reasonable time, different types of algorithms are proposed. Most of these algorithms are greedy algorithms to come to a solution. A greedy algorithm will recursively accept changes that give at that moment the best improvement to the design until no improvements are possible. This results in finding a local optimum within reasonable time, but it is unable to guarantee the optimal solution.

To solve the problem of deploying a sensor network a wireless deployment tool is developed within Nimbus [17]. This wireless deployment tool focuses on deploying WSN in buildings. The tool takes as input a set of sensors and their locations combined with the floor plan of the building. Since the locations of the sensors are predefined the coverage is of no concern for creating the deployment. So the tool only suggests locations for the placement of relay nodes and the sink node(s). All earlier mentioned network requirements are taken into account by this tool.

The tool uses a number of underlying models to support the optimisation; these include a battery model, topology model and a propagation model. The propagation model is the corner stone of the optimisation and is used to estimate the signal strengths between nodes. The model takes the geometric structure of the building and its material types to estimate the signal coverage.

The tool contains an agent-based algorithm. An agent is representative of a node (relay or sink) that is used to locally try to find an optimum, given a weighted sum of all requirements and constraints to

be optimised (the cost function). The agents iteratively check whether a move of a relay node or sink from one candidate position to another improves the design based on a cost function. If it does improve the design, the design is updated and re-evaluated. If after a certain number of tries there is no move found that would improve the design, the algorithm tries to add an extra node. If the network is already fully connected, this node will only be added if the weighted sum of the requirements will improve the design. This means that the improvement it makes must be better than the cost it involves. This algorithm terminates when a Pareto Optimal solution is reached.

As discussed in the previous section, there are various network quality metrics. The goal of the cost function is to define how those metrics are related to each other. For example, when the price of the network is of a high concern and the quality is not as important, the cost function could focus purely on the price, and thus the tool tries to create a network with a minimum number of components. But when the lifetime and latency should also be taken into account the cost function can be redefined to give a higher weight to those parameters. Since the tool makes its design choices based on this cost function, the cost function has a great impact on the final design.

When the tool is creating the design it will first try to move one of the relay nodes and or sinks in order to get a better result based on the cost function. This is done by iteratively increasing the range in which a move is considered. If after a pre-set amount of tries no successful move is found it tries to find a location where it can add a relay node. Again when after a pre-set number of iterations no location to add a relay node is found which would improve the design and the network is not fully connected a split is executed. A split means that a sink is added to split the network in two separate parts.

The placement decision is made at design time and does not consider dynamic changes during network operation. For example the behaviour of the network is strongly related to the used topology. Due to dynamic properties of a WSN it is difficult to predict the topology emerging from the dynamic routing algorithm being used. This can result in an unbalanced network, resulting in possible overloading of nodes and reduced lifetime of the network. An option to try to minimise those differences between the expected design and the actual design is to try to simulate the real world as accurate as possible. However this might lead to an extremely complex design tool and unacceptable running times of the algorithms.

Figure 7 shows an example of a deployment plan output by the tool. All blue lines show connections between nodes, the numbers on the links are the estimated received signal strengths and the battery shows the relative lifetimes of the nodes and the small circle is the sink.

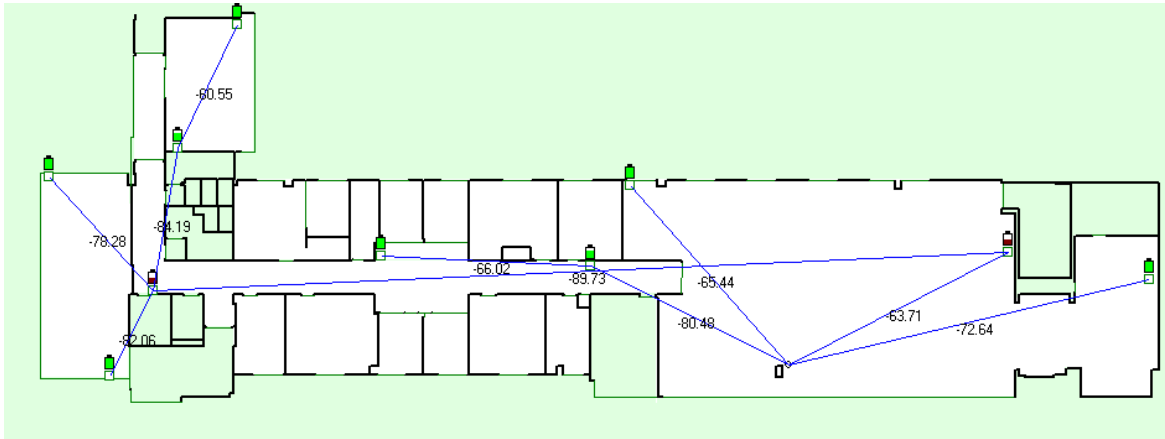

Figure 7: Example of a design output from the deployment tool

### 3.7 Conclusion

In this section the issues regarding the use WSN's and the current state of the art are described. The power constraints on the nodes, the creation of the routes in the network and how to deploy a WSN are main topics when working with WSN. Different types of networks will have different design choices. The for the nimbus test bed made design choices are also outlined in this section. For the rest of the document the nimbus test-bed will be used for all the tests and measurements.

## 4 How to analyse and configure a wireless sensor network

This section will describe what analysis of the network can be achieved using the Nimbus test bed. Since this test bed sends information about the status of its links back to the sink analysing the different properties of the network can be done very explicitly.

Next to the analysis of the Nimbus WSN a framework for QoS support is proposed. The goal of this QoS support is to let the network utilise its resources in such a way that it meets its requirements while optimising its lifetime.

During the process of analysing and configuring the WSN an analysis tool was developed as part of this research project. This tool is created in order to be able to quickly analyse a deployment and see what the values of the different information metrics are. This tool will be described at the end of this section.

### 4.1 Analysing a network

Analysing a WSN involves evaluating the quality of the network based on how it is operating and the data it generates. This analysis only looks at communication quality of the network and does not qualify the sensed data. The information extracted from the network can be analysed at three different abstraction levels:

- Physical layer
- Link layer
- Transport layer

The physical layer is about the quality of the signal used for communication. The RSSI and LQI of the received signals is measured and transmitted to the sink. Based on this information, the signal strengths of all used links can be analysed, which will give an indication of the quality of the physical layer.

The link layer indicates the quality of the link between two nodes. To do so the estimated number of transmissions per packet (ETX) is used. This number indicates how often on average a packet should be transmitted before it is successfully delivered. For example a node transmits 10 packets, and once a packet must be retransmitted to get back an acknowledgement thus the total number of transmissions becomes 11. Thus the ETX value will become  $11/10 = 1.1$ . Based on this number it is estimated that for the next packet we would on average need 1.1 transmissions. This ETX value will be used in order to analyse the link layer.

The transport layer analyses the connectivity of a node with the sink independent of its position in the network. All packets sent from the node contain a packet number. This number is then used by the sink to check whether all packets are received or that packets got dropped by the network. Based on this information models exist to analyse the connectivity of a node.

For analysis of the different metrics from the different layers, a test setup as shown in Figure 8 has been designed.

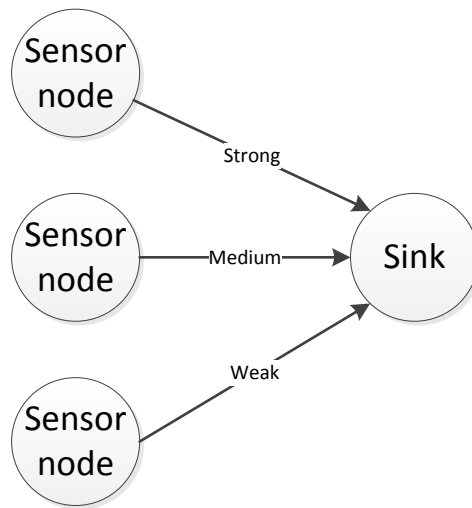

Figure 8: Test setup

This setup used single hop communication from a node straight to the sink so that the behaviour of a single links can be analysed. To do so the transmission power of the nodes is 10 dBm lower than the transmission power of the sink. This is because the relationship between the different quality metrics and the loss of data on the link from a node to its parent is measured. By lowering the transmission power of the nodes the link from the node to the sink is assumed to be weaker than from the sink to the node. Thus all the data lost in the network is assumed to be on this link.

Next to the lower transmission power are the nodes configured to use a single retransmission. A single retransmission is used since the nodes are unable to measure all the link indicators when no retransmissions are used. The ETX value, used for the link layer, is determined based on the number of retransmissions a node uses, when no retransmissions are used this value will always remain 1, and therefore no retransmissions can be used to analyse this metric. To stay consistent all analysis is done using a single retransmission.

This section will further discuss analysis of the three different layers in the network

#### 4.1.1 The physical layer

The physical layer analyses the quality of the signal used for communication. To do so the RSSI and LQI are used. The RSSI is an indicator that checks the power of the received signal whereas the link quality indicator combines the received power with the noise on the link. Both metrics are measured by the radio chip on the nodes, and those measurements are used for analysis.

Consider the following analogy, when two persons are talking to each other, the one who speaks should speak loud enough for the other to be heard. Speaking louder will not make the quality of the sound better, as long as the person can be heard communication can be established. The same holds for radio signal communications. When the signal is strong enough at the receiving side, a stronger signal will not improve the communication quality. The limit of what can be heard by the TelosB nodes is according to its datasheet -95dBm [15]. This section will look at what happens when the signal strength comes close to this value.

This setup actively measured the signal strengths and LQI values and report those back to the sink using the sensor data packets. Those packets contain the information about the signal strength of the

up and down link. Using this method means that the measurements are only known when the data packets are arrived at the sink. Thus the values of when the link fails are unknown. However by analysing the values for when the data is successfully transmitted will also give a good insight in how the links operate.

Another downside of this method is that the link quality metrics are extracted from the data packets. However since a sink does not generate data packets the signal strength values from the nodes to the sink is not actively measured. However the signal strength from the sink to the nodes can be measured and this combined with the fact that the transmission power of the nodes is 10 dBm lower will give a good estimation of the signal strength on the other link.

The signal strength and link quality values are matched to whether the previous packet was received or not. The packets are matched to the previous packets because the signal strength of the packet which is lost is unknown. This method uses the assumption that the measured values do not deviate much in relation to the previous measurement. By collecting a large data set the average reception rates of each signal strength value can be examined. This setup ran for a day and generated 12,500 measurements. The result is plotted in Figure 9.

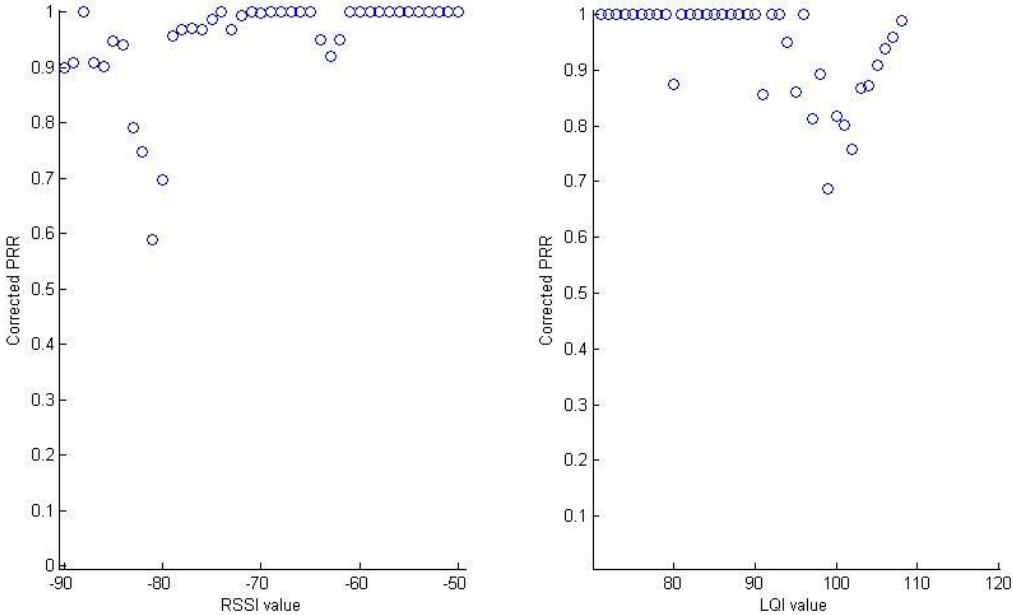

Figure 9: Relation between RSSI and LQI versus measured PRR

The plot in Figure 9 shows that for relative high signal strength values, the reception ratio remains unchanged at 100%. While if the signal drops below the -78 dBm, the reception ratio quickly drops. The results from these RSSI measurements should be shifted by -10 dBm. This is due to the used configuration. The measured signal is from the uplink, the sink to the node, Since the downlink over which the packets travel, from the node to the sink, is using a transmission power of -10dBm should the RSSI values be adjusted with this difference. This can be done since the attenuation on the path is assumed to be equal for both the up and down link. For the LQI values this compensation is harder, since this value is a combination of signal strength and noise therefore it is not a straight forward

shift of the values. Therefore this measurement is insufficient to accurately measure the relationship between the LQI and the packet reception ratio.

The nodes used a single retransmission per packet. This means that when a packet was not received, two consecutive packets were lost. The probability that 2 consecutive packets are lost is equal to the square root of the probability that a single packet is lost. Thus the actual packet reception is the squared value of what is measured. The corrected graph is shown in Figure 10.

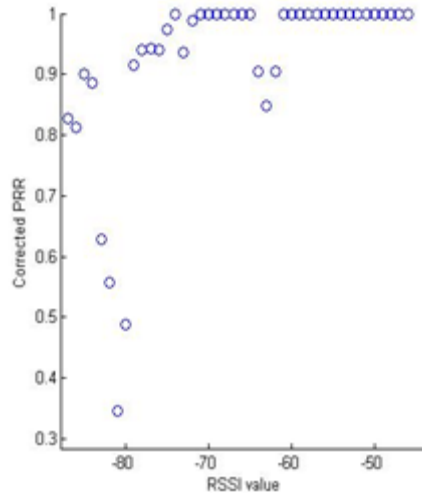

Figure 10: RSSI and LQI versus corrected measured PRR

In [18] a similar kind of test using different nodes with the same radio chip was conducted. To see if the measured behaviour in this research would also reflect the behaviour of the by the test-bed used nodes these results are matched. The results are shown in Figure 11

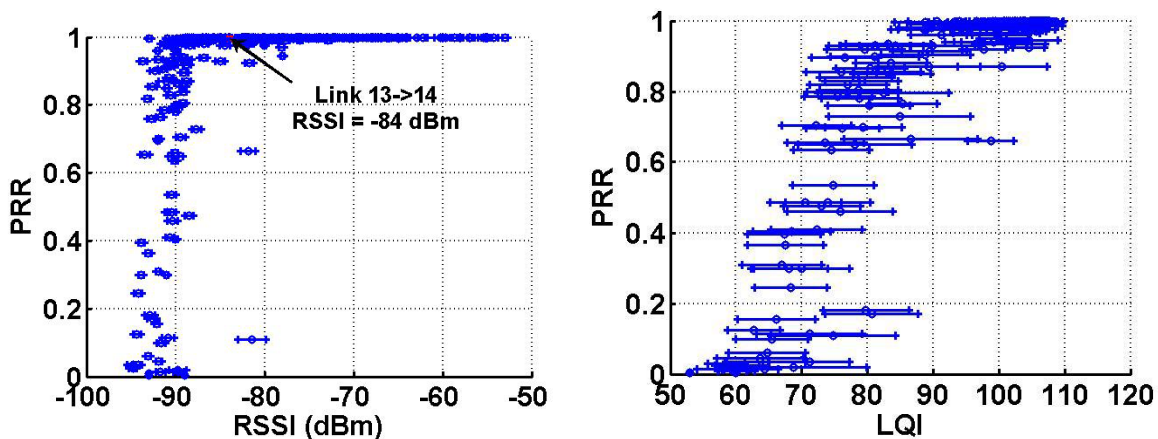

Figure 11: Results of [18]

The graph of the RSSI shows the same pattern as in the measurements described before. The measured PRR stays at a high level until a threshold is reached and then it quickly drops to very low levels. However the LQI graphs don't match. But this is due to different way of measuring them. In this research where measured at the receiving side. This results in a better relationship between PRR than in the previous measurement. As those two graphs show there is a stronger relation between



the RSSI and packet reception ratio than between the LQI and packet reception ratio. Due to the results of this research I have decided not to use the LQI but only to focus on the RSSI.

#### 4.1.2 The link layer

The link layer is about identifying the quality of the connection between two nodes. This is done based on how often a packet is successfully transmitted; this is measured by the ETX. The ETX metric can be expressed as the mathematical Equation 1.

$$ETX = \frac{1}{PRR_{up} * PRR_{down}}$$

Equation 1 ETX equation [19]

Since the ETX is also used by the routing protocol Hydro to select routes a modification to this formula is implemented on the nodes. The modification, Equation 2, determines the probability a packet is successfully transmitted based on the configuration of the node.

$$ETX \text{ test bed} = \sqrt{NrOf \text{ retransmission} + 1} \frac{1}{PRR_{up} * PRR_{down}}$$

Equation 2: Modified ETX formula

This ETX figure reflects the probability that a packet is successfully transmitted on both the up and down link. The sensor data will only use the downlink, and thus the probability of that the sensor data arrives at the sink is independent of the uplink. Therefore only the downlink should be examined. In order to estimate what percentage of packets that is successfully transmitted over the downlink the ETX value can be used.

To estimate the up and down links separately the links are assumed to be symmetric when both nodes use the same transmission power. Even though the used radio chip, CC2420, does not have perfect symmetric up and down links it is assumed that when the transmission powers of both communicating nodes are equal the link PRR for the up and down link are equal. This is however not the case. The antenna used on the nodes is omnidirectional however the gain does slightly vary based on the orientation of the node. The measured difference between the up and downlink is around the 5dBm. In this section the simplification is used that up and downlink can be assumed equal when the transmission powers of the two communicating nodes are equal. It is assumed that this simplification will yield accurate estimations.

In case of symmetric up and down links the link PRR from a node to its parent can be calculated using Equation 3. The link PRR is calculated independent of the configuration. Thus this metric indicates the probability that a packet is successfully sent over the down link.

$$Link \ PRR_{up} = Link \ PRR_{down} = \sqrt{Nr \ of \ retransmissions + 1} \frac{1}{ETX}$$

Equation 3: Physical PRR from ETX for equal up and down links

When the up and down links are not symmetric due to for example differences in transmission power between the two communicating nodes this formula can be simplified to Equation 4

$$\text{Link PRR}_{up} = \frac{1}{ETX}^{Nr\ of\ retransmissions+1} \quad \text{or} \quad \text{Link PRR}_{down} = \frac{1}{ETX}^{Nr\ of\ retransmissions+1}$$

**Equation 4: Physical PRR for unequal up and down links**

Since one node is using more transmission power we assume that this link is of higher quality than the other. When communication is still possible the higher quality link is assumed to result in a link PRR of 100% and thus all the lost packets are assumed to be on the weak link. To verify the relationship between the ETX and the PRR of the down link, the same type of measurement as with the RSSI and LQI was used. This resulted in the following graph:

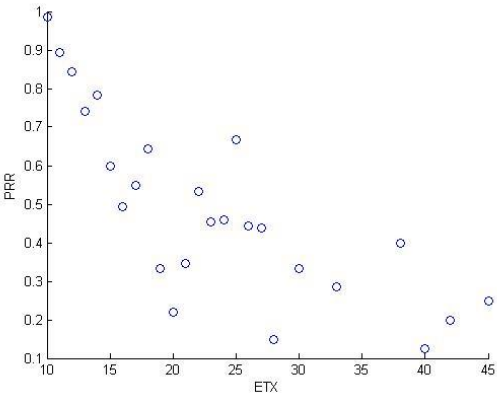

**Figure 12: Relationship measured PRR versus the ETX**

From this data, the estimated link PRR of the uplink can be determined. First the relation without taking the number of retransmissions is examined. This is done to verify if the ETX metric accurately estimates the probability that a packet is transmitted over the link.

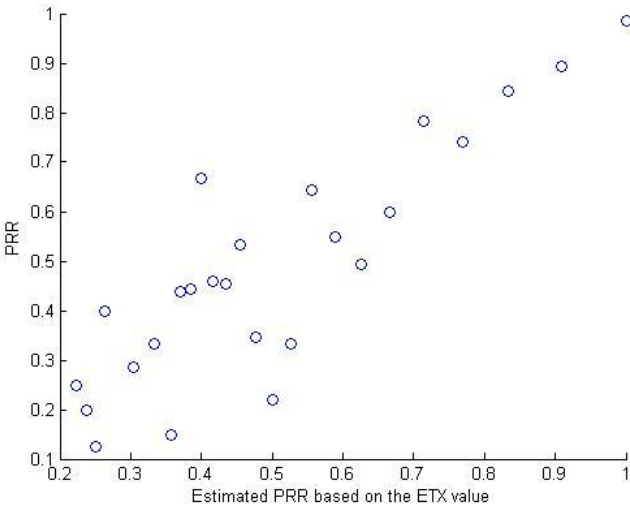

**Figure 13 Link PRR based on ETX values versus measured PRR**

This graph, Figure 13, shows that the relationship between the estimated link quality and the actual link quality. The graph shows that the ETX calculation on the nodes does take the number of retransmissions into account when calculating the link quality. This is due to the linear relation between the packet reception ratio and the ETX value while the nodes were using a single retransmission. If the ETX calculation would not take the number of retransmissions into account this graph would not have shown a linear relationship. A limitation of this metric is its precision. The nodes report the ETX values with a precision of 0.1. Thus the first step from 1 to 1.1 reflects a change in link quality of 9%. This is a big step when trying to estimate the quality of the link.

Another downside of this method is that it does not check the quality of the link from the node to its parent, but looks at the link in both ways. When using the network to obtain sensing data the downlink is far more important, since on this link the data will travel from the nodes to the sink, than the uplink. So it would be better when a method is used that only analyses the downlink instead of both the up and downlink. When only the downlink is measured the assumption that the up and downlink are equal is not needed to estimate the quality of the downlink which should lead to better measurements of the downlink.

#### 4.1.3 The transport layer

The transport layer is about the connectivity between a node and the sink independent of the node's location in the network and the configuration of the network. This connectivity is analysed based on the number of received packets. The simplest method is to look at the average number of received packets over a time span, but also more complex models exist. All those methods are coming from the digital signal processing field. Each method results in a number between 0 and 100% quality which should indicate the probability that a packet successfully travels through the network. This metric is called the path quality. There is not much literature about path quality estimates. Therefore I decided to use the link quality estimators to qualify the path quality.

In [2] different methods are introduced to estimate the link quality based on the actual received packets. Some of these methods are mentioned here. Those methods work based on the information whether a packet is received or dropped. Since the number of packets created by the nodes is available the sink is able to determine this input and thus to use these models. To determine the end-to-end PRR two different methods are presented. The first method is using the finite input response filter (FIR) and the second method uses the infinite input response filter (IIR).

The finite input response filter is a filter type which uses a window. The most basic FIR filter is the moving average filter (MAF). This filter uses a window of a certain length and returns the average value over all inputs. The input in this situation is a Boolean value 1 if a packet was received and 0 if it was not received. Calculating the average over multiple samples gives the most basic form of the packet reception ratio; this method is also called the packet reception ratio. The formula to determine the end-to-end PRR is given by Equation 5:

$$PRR^{\tau} = \frac{1}{w} \sum_{k=0}^{w-1} Link^{\tau-k}$$

Equation 5: Packet reception ratio formula from [20]

In this equation the tau symbol indicates the round which is evaluated. The Link is a Boolean value indicating whether the packet from that round is received or not, and the w is the size of the window.

Next to the basic moving average filter is also a Time Weighted Moving Average Filter (TWMAF). The goal of this technique is to make the more recent samples more important than the older ones. This is done so that the result can more quickly adapt to changes in the path quality. In the previous formula a sample at the end of the window has the exact same influence on the packet reception ratio as the newest sample. This formula assumes that the more recent samples can give a more accurate prediction of the path quality than the older ones. This results in Equation 6:

$$TWMA^{\tau} = \frac{\sum_{k=0}^{w-1} ((w-k) \times Link^{\tau-k})}{\sum_{k=1}^w k}$$

Equation 6: Time weighted moving average from [20]

The TWMA and end-to-end PRR method from equation 7 are both from the FIR class. The next exponentially weighted moving average (EWMA) filter is a IIR filter. It assumes that the influence of a sample on the packet reception ratio decreases exponentially. Calculation of the packet reception ratio is done by

$$EWMA^{\tau} = \alpha \times Link^{\tau} + (1 - \alpha) \times EWMA^{\tau-1}$$

Equation 8: Exponentially Weighted Moving Average from [20]

This filter does not use a window; instead it uses a recursive equation. The result of the previous calculation is used as input for the next one. The value  $\alpha$ , that should always be  $0 < \alpha < 1$ , is the exponential factor that determines how quickly values fade out, and thus how important the new values are. When  $\alpha$  is close to one the equation almost only relies on the last sample. When the value is close to 0 the average of an almost infinite time is used.

All these methods have in common that they try to derive the path quality based on the observed behaviour of the path. The problem of qualifying the path is that a period of time is required to estimate the quality of the path. Choosing the period of time to use for the estimation can be hard. When the period is small, the influence of a single sample is relatively large resulting in an unstable qualification. For example when the PPR method is used on a window of 10 samples, a single measurement has 10% influence which results in a low precision measurement. From statistics we know that the estimated error for a set of samples from a Bernoulli trial, which is very similar to the end-to-end PRR method, is Equation 9:

$$Estimated\ error = \sqrt{\frac{p * (1 - p)}{n}}$$

Equation 9: Estimated error of an estimated end-to-end PRR

For packet reception ratios this results in the following relation between packet reception ratios, window sizes and estimated errors.

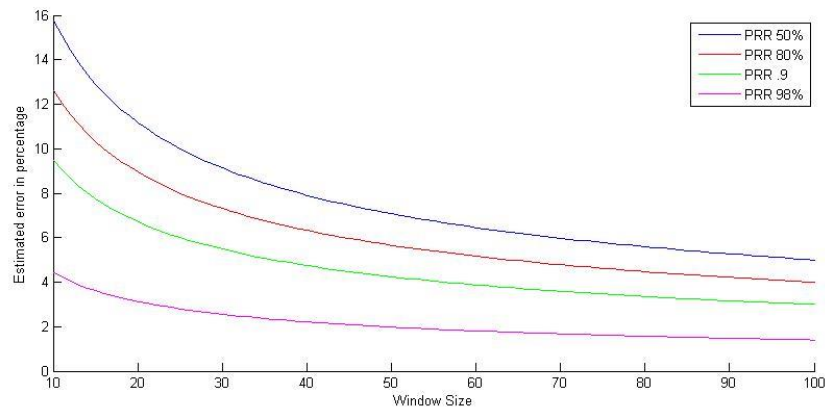

**Equation 10: Relation between window size, packet reception ratio and estimated error**

This graph shows that not only the smaller the window size the bigger the estimated error ratio but also that the estimation shows a larger error rate when the path stability decreases. When for example a window size of 100 is used and once per 5 minutes a sample is taken the oldest sample is 500 minutes or 8.3 hours old. Does an 8.3 hour old sample still contain valid information about the current path's state? So in general the smaller the window size the more accurate the information of the samples but the more unstable the classification.

The goal of estimating the packet reception ratio is to be able to say something about the quality of the path at the current time. To be able to see which methods and configurations have the best reflection of what is going to happen in the future all methods are tested. The test consists of an implementation of the method and a long run evaluation.

The evaluation is done by a deployed network where a node used 2 hops to connect the the sink. Both hops contained a link that was of lower quality, on one node an average of 20% of the packets was lost, the other one 5%. All the end-to-end PRR estimators from the node that relied on both of these links are used for this analysis. The end-to-end PRR estimator is combined with the check whether the next packet is successfully transported over the path. This check is related to the next packet since the end-to-end PRR estimator is determined based on the previous values. In order to make the analysis values independent of the estimator value is compared to whether the next packet arrived. At the end the results are sorted in bins based on the path quality estimator. If the path quality estimator is able to predict the future the average value of the check should match the number of the estimator, or at least show a relation.

This dataset used for this evaluation is done with 13,921 samples. The node sent one sensor packet every minute and a statistics packet every 5 minutes. The results are illustrated in Figure 14.

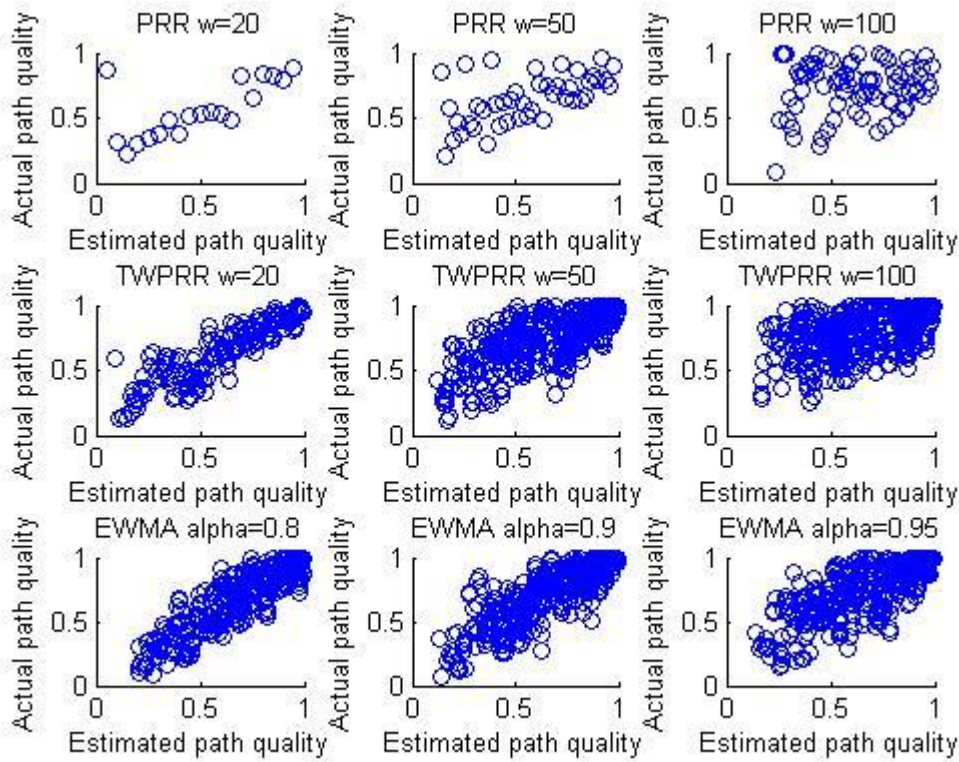

Figure 14 Relation between estimated path quality and actual path quality

This image illustrates that the large PRR methods did not give accurate estimations. This is probably due to the time that measurements are related to the link quality. The PRR method with the window of 20 samples does show a reasonable relation the link quality. For all three methods the ones that are able to respond quickly performed better than the ones that try to be more accurate. Over all the EWMA method with an exponential factor of 0.8 gave the best result. Just as with the path quality prediction of the end-to-end PRR result, also for the TWPRR and EWMA the smaller window/smaller coefficient implementations lead to better results.

#### 4.1.4 Characteristics of a failing link

Next to analysing the characteristics of the parameters from the different communication layers to the measured PRR, the characteristics of a link which is at the edge of its communication capabilities is also considered. How does a link behave when it is close to losing connection and what quality could the link still deliver in this situation?

As can be concluded from the physical layer analysis, the quality of the link can be well described by the signal strength of the link. When this value comes close to the edge of it capabilities, in the test bed -85 dBm, the quality of the link will quickly degrade. For the ETX such strong relations did not appear. This however does not mean that those do not exist. The graphs plotted for analysis of the ETX did not say anything about how often certain values occurred. Figure 15 shows a histogram of the relationship between the link quality and how many measurements were received with its corresponding value.

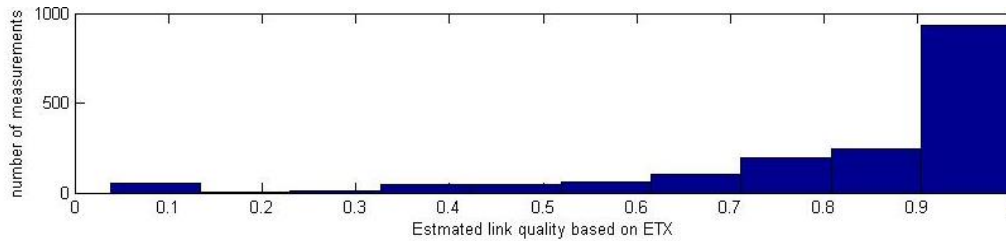

Figure 15: Histogram number of measurements and corresponding packet reception ratio

The histogram is constructed based on the communication of a single node transmitting its data back to the sink with an RSSI value between -87dBm and -90dBm. The histogram shows on the x axis the estimated PRR derived from the ETX value independent of its configuration. On the Y axis the number of instances a value was measured is counted. What these graphs show is that when the links are dropping packets, but there is still a working connection the majority of the time it is still able to successfully transmit a packet. Over 60 % of the time the link is in a state in which it is able to transmit over half of its packets. This shows that even when a link is of a bad quality it is still likely to successful deliver packets with a probability over more than 50%. If the reception rate goes below the 50% the link more likely to completely fail than to successfully deliver a low percentage of its packets.

This information combined with the information that the link quality quickly drops when the RSSI drops below -85dBm leads to a conclusion that if a link drops packets the packet loss is very likely to be between 0% and 40%. Thus links that are the edge of its communication capabilities are still of a good enough quality that the links can still successfully transmit data. Several experimental runs have been conducted where nodes were pushed even further away from each other but a PRR of below 50% did not show up. Thus when the link quality is decreasing further total disconnection is more likely to occur than extremely low link PRRs.

## 4.2 Configuring the network

Once a WSN is physically deployed the configuration of the network is the next step. The possible routes and their corresponding path qualities are highly determined by the physical deployment; however the actual network quality relies on how the network utilises its resources.

Due to the properties of the radio communication the sensor network is most likely going to lose packets. This should be acceptable and the network should compensate either in the application by accepting the packet loss or in the network by increasing the reliability of the network. Therefore it is important to consider will the application have its requirements for the WSN regarding the reliability or the network and should the network use its resources to try to deliver the requirements.

Once a wireless network is deployed it is still highly configurable, properties like transmission power, sensing frequency and retransmission rates are configurable post deployment. The goal of configuring the WSN is to create a configuration that should meet the requirements. This is known as quality of service support. To address this issue a Quality of Service (QoS) configuration framework is proposed. This framework specifies different abstraction layers where the quality of the network is measured and configured. For each layer, possible options are suggested to be able to change the network's configurations to the requirements of the application using it.

As the framework is targeted at the Nimbus WSN where nodes periodically send a sensing packet for the application, no event-based configurations are taken into account. This framework could be extended for event-based sensor networks but this is not addressed in this research.

**4.2.1 The framework**

The framework consists of four layers. Each layer is describing a different abstraction of the WSN. The first layer is the Application layer. In this layer the Quality of Service that an application or user requests from the network is defined. The requirements in this layer consist of the data period, maximum latency, minimum lifetime and reliability; these metrics can be set per individual node. The second layer is the transport layer. This layer describes the connectivity of a node with its corresponding sink. The end-to-end connectivity of each individual node is analysed in this layer. The third layer is the link layer. This layer looks into the quality of the connection of a node with its parent. And the fourth layer is the physical layer; in this layer the quality of the radio signal is analysed. The framework is illustrated in Figure 16.

| Wireless Sensor Network QoS |   |  |              |
|-----------------------------|---|--|--------------|
| Layer                       | Layer input   | Layer outputs  | Illustration |
| Application layer           | <div style="display: flex; justify-content: space-around;"> <div style="border: 1px solid black; padding: 5px; width: 20%;">Data latency</div> <div style="border: 1px solid black; padding: 5px; width: 20%;">Sensing frequency</div> <div style="border: 1px solid black; padding: 5px; width: 20%;">Network lifetime</div> <div style="border: 1px solid black; padding: 5px; width: 20%;">Data reliability</div> </div> | <div style="border: 1px solid black; padding: 5px; width: 50%; margin: auto;">QoS Met</div>  |              |
| Transport layer             | <div style="display: flex; justify-content: space-around;"> <div style="border: 1px solid black; padding: 5px; width: 20%;">sensing period</div> <div style="border: 1px solid black; padding: 5px; width: 20%;">Number of duplications</div> </div>  | <div style="display: flex; justify-content: space-around;"> <div style="border: 1px solid black; padding: 5px; width: 20%;">Network Topology</div> <div style="border: 1px solid black; padding: 5px; width: 20%;">End to end PRR</div> </div> |              |
| Link layer                  | <div style="border: 1px solid black; padding: 5px; width: 50%; margin: auto;">Number of retransmissions</div>   | <div style="border: 1px solid black; padding: 5px; width: 50%; margin: auto;">ETX</div>  |              |
| Physical layer              | <div style="border: 1px solid black; padding: 5px; width: 50%; margin: auto;">Transmission power</div>  | <div style="display: flex; justify-content: space-around;"> <div style="border: 1px solid black; padding: 5px; width: 20%;">RSSI</div> <div style="border: 1px solid black; padding: 5px; width: 20%;">LQI</div> </div>                        |              |

**Figure 16 Quality of Service for wireless sensor networks framework**

All inputs in blue are pre-defined requirements. The Application layer is driven by user requirements and is therefore a pre-defined input for the framework. All metrics in green are configuration parameters. These parameters are the tools which can be used to change the behaviour of the network. These parameters should be used to ensure that the network meets the defined requirements while optimizing the networks lifetime. The network performance metrics are illustrated in orange. These outputs are the metrics that can be extracted from the operating network and are used for (re)evaluation of the current settings.

An explanation of each layer and their corresponding configurations and verifications are given in the following sections. First the configurations or network inputs are discussed; then the verifications or network outputs are discussed.



The problem when configuring a network is how to respond to dynamic behaviours. Does the network need to reconfigure as soon as a better configuration could be derived, or should this be done periodically. The first option could lead to an unstable network which is reconfiguring continuously, whereas the periodic reconfigurations could lead to unnecessary network failure, or a waste of resources.

All sensor/network configurations are derived based on the application requirements. Thus the required quality of the links depends on what the application requires from the network. When for example the application does not need a high reliability then the loss of a packet in the network can be tolerated, this in contradiction to the scenario where the application layer has a high reliability requirement. In this section first the configuration options of each layer and their impacts on the behaviour of the network are described. After this the method to suggest a new configuration is introduced.

#### 4.2.2 Application layer

In this research the type of sensing or actuation is not relevant since only the communication quality of the network is considered. An application could define its requirements based on the following parameters:

- Sensing period
- Reliability
- Network lifetime

The sensing period is the data dependency of the application; the reliability regards the communication quality of the network whereas the network lifetime is a resource restriction. The reliability and the network lifetime restrict each other which could cause the network to be unconfigurable. When there is no configuration that matches all the requirements the deployment should be re-evaluated. The framework that has been developed will only take the reliability into account, and is thus not restricted by lifetime constraints. Next to that it does not take throughput into account. The used communication channel has a throughput of 250 kbps while a packet is more or less 120 bytes long. Per second more than 2000 packets could be transmitted. The used network for buildings has typical sensing periods in the seconds or minutes. The throughput is in this case thus of not critical. Latency is not taken into account in this framework because of the incapability of the network to measure it. However when the framework would be extended further research should include the throughput, lifetime, and latency.

##### 4.2.2.1 Sensing period

The sensing period specifies the amount of time between two consecutive readings from a location of interest. This can differ for each sensor, or each type of sensor depending on the application.

##### 4.2.2.2 Reliability

Due to the lousy properties of the radio channel an absolute certainty that packets arrive can never be given. Therefore the application should specify a minimum reliability. This reliability is the percentage of readings that are successfully delivered to the application.

##### 4.2.2.3 Network lifetime

The lifetime of the network defines the maintenance work required to keep the application running. For many applications a minimum operation time should be guaranteed. The deployment should be

aware of this minimum time, and try to adapt its configuration to meet the requirement. The lifetime of a node is strongly related to the activity of the radio chip. By lowering the transmission power and/or decreasing the load on the radio chip the lifetime of the node can be extended. The lifetime of the network has multiple definitions, but all of them have in common that nodes should live as long as possible.

#### **4.2.2.4 Verification of the reliability**

To measure the reliability of a sensor a moving average filter is used. At the end of every period a check is done whether the sensor data from that period is received or not. This method checks whether within the period one or multiple sensor readings are received does not matter, since according to the specification at least one reading per period is required. The moving average filter will determine after each period the reliability of the link at that moment of time.

The outcome heavily relies on the size of the window. A large window will have a high accuracy, but will also allow longer bursts of packet loss. For example a reliability of 95% and a window size of 100 can accept at most 5 consecutive missed packets and has an precision of 1%. A more accurate estimation is not possible using a windows size of a 100 samples. When a window size of 1000 is used the maximum consecutive missed packets is 50 and will have a precision of 0.1%.

The size of the window will have to be set according to the application's requirement to be sure that the required accuracy can be reached and that the maximum number of possible consecutive missed packets does not exceed the specification. Multiple windows can be created per node, for example when different sensors need different windows.

#### **4.2.3 The transport layer**

Once the application requirements are set the transport layer should ensure that despite the characteristics of the WSN the application gets the service required. To do so the operation metrics from the network are used as inputs and configuration settings are used to try to let the network deliver the required quality.

In the framework, the assumption is made that the links can be modelled as a Bernoulli trial using the PRR of the links. In order to use a Bernoulli trial it should be possible to model the loss of data a probability  $p$  and the events of data loss should be unrelated to each other. This probability is assumed to be equal to the link PRR. This method has also been used to simulate link losses for WSN by other researchers [21]. All formulas used in this section come from the Bernoulli theory and mathematical rewrite rules.

The option on this layer to change the behaviour of the network is to configure the number of duplicated packets transmitted per period. When the reliability requirement is not met, the amount of lost packets in the network is too high. This can be compensated by injecting multiplications of packets.

##### **4.2.3.1 The number of duplications**

The application requires periodic updates from a sensor. The minimum update frequency is defined by the application. Only a case where no packets are lost in the network will the requirement be met with 100% reliability. In all other cases a chance of not meeting the requirements is present. The probability that a packet is not delivered to the sink is defined by Equation 11. This equation assumes that a sensor reading is transmitted using a single packet, thus not fragmented which is the case in

the test bed. Based on this assumption the probability that a packet is delivered successfully is equal to the probability that a sensor reading is delivered successfully.

$$Reliability = 1 - (1 - \text{end to end PRR})^{Nr \text{ of duplicaitons}}$$

Equation 11 Percentage of Application data interval deadlines met

To ensure the application requirement is met, it might be necessary to send more than one packet per period. The probability that the requirement is met could be calculated based on the probability that a packet gets lost which equals 1 minus the packet reception ratio to the power of the number of packets sent per interval. The end-to-end PRR options introduced in 4.1.3 can be used in this formula for the end-to-end PRR. This number is defined by the network; the number of duplications is the configuration parameter in this formula. Changing the number of duplications can be used to meet the reliability requirement

Since the PRR is a metric that can be derived from the active deployment and the minimum reliability is specified by the application only the number of duplications can be configured to meet the requirement. Rewriting Equation 11 gives the following result for setting the sensing interval time.

$$Number \text{ of duplications} = \left\lceil \frac{\log(1 - reliability)}{\log(1 - prr)} \right\rceil$$

Equation 12 Minimal sensing interval length

The following chart shows the impact of the packet reception and the minimum reliability influence on the sensing interval period.

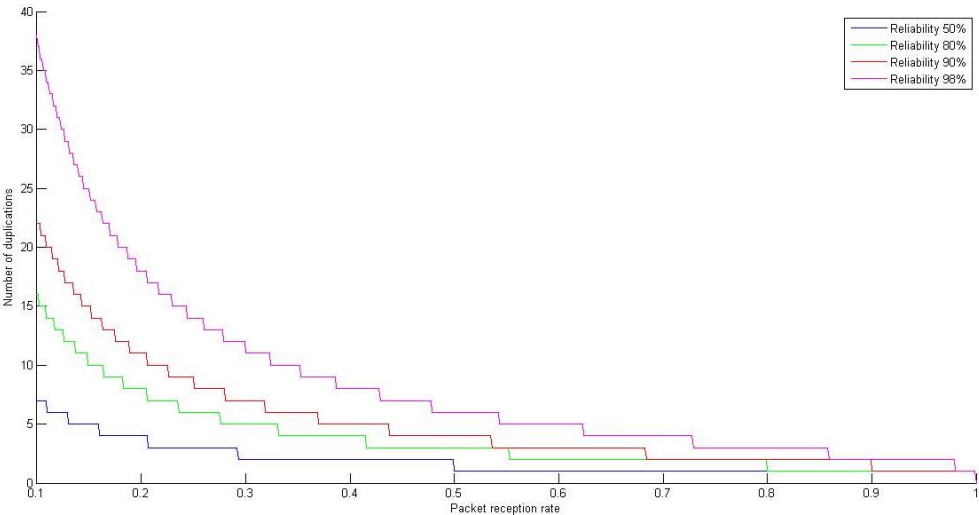

Figure 17 Relationship between end-to-end PRR and minimum reliability

This graph shows on the x axis the packet reception ratio of the link from a node to the sink; this is the metric that will be determined by the network. The y axis shows the required number of retransmissions to meet the application requirement, configuration parameter of the network. The four different lines in this graph relate to four different application requirements. So for example the

network has an end to end packet reception ratio of 0.8 and the application requires 98% hit ratio. Then the required number of duplications equals:

$$\text{Number of duplications} = \left\lceil \frac{\log(1 - 0.98)}{\log(1 - 0.8)} \right\rceil = 3$$

So with these settings the number of injected packets of the node should be three times higher than the required minimum number in order to meet the requirements of the application.

To define this value, the relation between the load on the nodes and the reliability needs to be taken into account. The closer the hit ratio comes to 100%, the higher the load on the nodes which results in a lower lifetime. So a trade-off between lifetime of the network and quality of the network should be made.

Next to the minimum number of duplications there are also a maximum number of duplications. The nodes are all limited to the amount of energy they are allowed to use due to the lifetime requirement. To exactly determine the maximum number of retransmissions is challenging. To do so the relationship between a nodes lifetime and sensing period and number of duplications should be determined. A node uses more power when transmitting more packets, but the lifetime does not only depend on the number of packets sent. Therefore, a model is required to come up with a good maximum sensing frequency. This is research where other people within Nimbus are working on and therefore I did not go any deeper into this subject than only stating that the sensing period and number of duplications will be bounded on both sides. This research focuses on the restrictions on one side. Since the lifetime of the network is not included into this version of the framework it is only stated that the number should be kept at a minimum and in a later version restrictions could be made on this number.

#### 4.2.4 The link layer

The link layer defines the quality for the communications for a node to its parent. The quality of the link is defined by its packet reception ratio. The packet reception ratio depends on the quality of the physical link and the number of retransmissions for a packet whereas the delay depends on the duty cycle time. The quality of the physical link will define the probability that a single packet is transmitted successfully and the combination between the probability that a packet is transmitted successfully and the number of retransmissions will define the link PRR. The end-to-end PRR of an end to end link can be determined by the product of the packet reception ratios of all the individual links on the path from a node to the sink, see Equation 13. When improving the packet reception ratio of a link all nodes that use that link will benefit from this improvement.

$$\text{End to end PRR} = \prod_{\text{Link } i \text{ on the path node-sink}} PRR_i$$

Equation 13 End to end packet reception ratio

To improve the quality of a link the same principle is used as for the transport layer. To improve the link quality multiple instances of the packet will be transmitted in order to create a stronger link. On the link layer the packets will not simply be duplicated but rather a retransmission of the same packet, and is only transmitted when an acknowledgement is not received.

When a node sends a packet to its parent it expects that the parent will send back an acknowledgement after it successfully received the packet. If a node does not receive the acknowledgement after a pre-set period of time it retransmits that packet. The maximum number of retransmissions is bounded in order not to overflow the nodes memory, to maintain lifetime and not to block the communication channel an infinite amount of time for transmitting an unsuccessful packet.

This bounded number of retransmissions is what should be configured at this layer. When increasing the number of retransmissions the link quality will increase and lowering it enables the node to live longer. Therefore, the minimum required number of retransmissions should be found that would still maintain an acceptable level of link quality.

The formula for the link quality is almost the same as for the end-to-end packet reception ratio. However the packet reception ratio of a single link is derived from the ETX value. In section 4.1.2 the relation between the ETX value and the link reception ratio is discussed. This described method is used to obtain the link packet reception ratio. Therefore the formula becomes

$$\text{Link quality} = 1 - (1 - \text{Link prr})^{\text{Nr of retransmissions}}$$

Equation 14: Link quality

The impact of the number of retransmissions on the link PRR is illustrated in Figure 18.

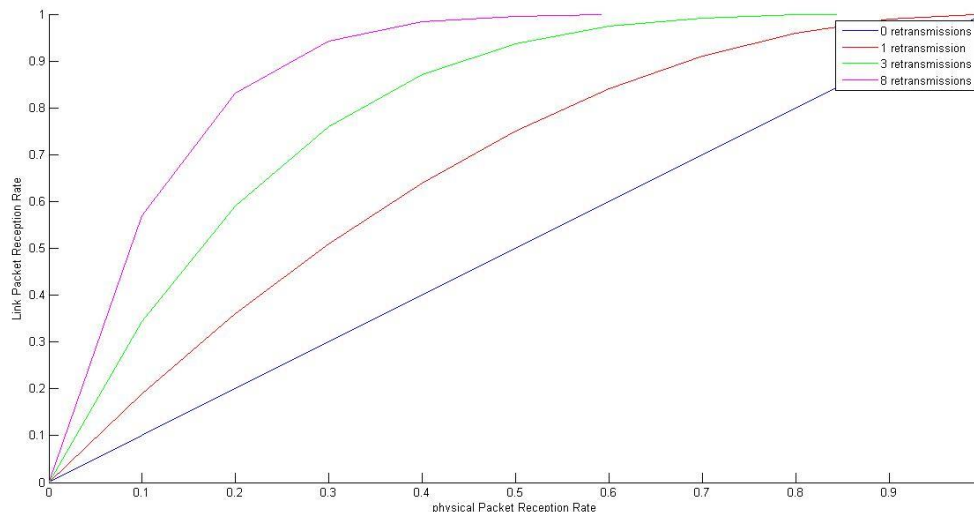

Figure 18: Relation between the number of retransmissions and the link packet reception ratio

This figure shows that the higher the number of retransmissions is the lower the physical PRR needs to be to maintain a good link PRR.

As is stated in section 4.1.4, a link will barely ever drop below a packet reception ratio of 0.6. Therefore a threshold for the maximum recoverable Physical PRR can be set at 0.6. So recovering from physical PRRs of under 0.6 is unnecessary; those links will be qualified as unstable. Those links qualities should be avoided and when they occur a redeployment should be considered. Since a retransmission rate of 3 with a physical PRR of 0.6 will give a link PRR of 0.97 there is no need to use higher retransmission rates than 3.

$$1 - (1 - 0.6)^4 = 0.97$$

If a retransmission rate of 3 is used and a transmitter is using its maximal power and the link is still not meeting its requirements the link will be qualified as unstable and could cause the node and all nodes it relays the data for to miss their application requirements.

#### 4.2.5 The physical layer

The configuration option for the physical layer consists of the adaptation of changing the transmission power. Since the majority of a nodes energy is consumed by receiving and transmitting data, reducing the transmission power shall have great influence on the lifetime of a node. Table 1 shows the relation between the configured transmission power and the current drawn by the transmitter.

| Transmission power in dBm | Current drawn |
|---------------------------|---------------|
| 0                         | 17.4          |
| -1                        | 16.5          |
| -3                        | 15.2          |
| -5                        | 13.9          |
| -7                        | 12.5          |
| -10                       | 11.2          |
| -15                       | 9.9           |
| -25                       | 8.5           |

Table 1: Transmission power versus current drawn [22]

As was concluded in section 4.1.1 it is important to maintain signal strength at the receiving node of more than -85 dBm in order to maintain a good link quality. This should thus be guaranteed when lowering the transmission power of a node, or else the communication link between the two nodes shall suffer from the reconfiguration.

Since all nodes measure the RSSI values of all links and report those back to the sink, these values are known for evaluation of the links. When evaluating the transmission power of a node all incoming and outgoing links should be taken into account. Only when the signals on all links are high enough to lower the transmission power should it be lowered. And the other way around is the same, when there is one link whose received power is too low the transmission power of the node should be increased. By doing this for all nodes the transmission powers of all nodes can be determined, and the lifetime of some of the nodes can be increased without the loss of quality for the network.

### 4.3 Determining the required configuration

The relationship between the possible configurations and the effect on the behaviour of the network is known a model to determine the configuration of the network is the next step. The configuration of the network will be done in two independent stages. One stage determines the transmission power of all the nodes, the physical layer configuration, and the other stage determines the number of retransmissions and packet duplications, the link layer and the transport layer configurations.

#### 4.3.1 The physical layer configuration

The configuration of the physical layer takes as input the RSSI values of all links. It is known from the analysis of the physical layer that as long as the received RSSI is higher than -85 dBm the quality of

the link will remain the same. This is important due to this property the configuration of the physical layer and the link and transport layer can be done independently of each other. The goal of the configuration will be to use a minimum transmission power and maintaining the RSSI values of all links above the -85 dBm.

For setting the transmission power a limited number of possible transmission powers are used. The possible settings are:

- 0 dBm
- -7 dBm
- -15 dBm

To determine a node's transmission power configuration the following three checks are used:

$$\text{Check 3} = \forall(\text{link } i \text{ of node})(\text{RSSI } i - 0 > -85)$$

$$\text{Check 2} = \forall(\text{link } i \text{ of node})(\text{RSSI } i - 7 > -85)$$

$$\text{Check 1} = \forall(\text{link } i \text{ of node})(\text{RSSI } i - 15 > -85)$$

These checks involve all incoming and outgoing links on a node. Since a node requests an acknowledgment after sending a packet is important that the link quality for as well the uplink as the downlink are of a good quality.

All three checks will return a Boolean value on whether the value formula was true or false. The first check that returns true determines the configuration for that node. Thus when all links will remain higher than -85 dBm after subtracting 15 from the current signal, -15 dBm will be used as transmission power. When none of the three checks return true the link will be configured with the maximum transmission power but the link is likely to have a weak link. When this occurs it is up to the routing protocol to decide whether there are other links which can be used that might have a better quality.

#### 4.3.2 The link layer and transport layer configuration

The number of retransmissions, link layer, on a link and duplications of a packet, transport layer, will be configured together since both configurations are strongly related. The goal of configuring the link and transport layer is to ensure the reliability of the nodes. The reliability was defined as the probability that per sensing period one packet of a node is received by the sink.

Both the duplications and retransmissions will impact the reliability of the nodes. Next to that they will also impact the load on the network and thus its lifetime. Therefore, it is important that a minimum number of retransmissions and duplications are used while maintaining the required reliability of the nodes.

The relationship between configuration options and the reliability was already given in section 4.2.4 for the link layer and section 4.2.3 for the transport layer. The relation between the load on the network and the two configuration options is given by Equation 15 for the duplications and Equation 16 for the retransmissions.

$$\text{load in packets per second on a node} = \frac{\text{Duplications}}{\text{sensing period}} + \sum_{\text{child } i} \text{load}_i * \text{link PRR}_i$$

Equation 15: Load on the node in packets /s

$$\text{load in transmissions /second} = \sum_{i=0}^{\text{Retransmissions}} \text{load} * (1 - \text{Physical PRR})^i$$

Equation 16: Load on link in transmitted packets /s per node

These two formulas are used to determine the load in transmitted packets per second per node. To determine the load on the nodes first the number of packets that a node should propagate through its downlink should be determined, Equation 15. When a node inserts a packet in the network it tries to successfully transmit it to its parent. When this parent is not the sink, it will propagate the packet further down the network. However when a packet fails to reach the parent, it will not be propagated through the network and thus not induce extra load on the nodes in the network. Therefore Equation 16 calculates the load on a node based on the load it creates itself, and the load of its children multiplied by the probability that these packets reach the node.

By iteratively doing this for all nodes, the load in packets per second becomes attainable. However the actual load should be determined based on the number of times a node actually transmits a packet. This is determined based on the probability that a packet is successfully delivered to a nodes parent and the number of retransmissions. When a transmission fails the packet is retransmitted until the retransmission limit is reached. The larger the probability that a transmission fails the more often retransmissions are required. Equation 17 shows this relation.

When configuring the network those formulas are used to see the impact of the configuration on the network. The goal is to minimize the number of packets transmitted by all nodes together, a global minimum load.

To determine the required number of retransmissions and duplications only the ETX values are used. This is done because both the retransmissions and duplications are used to optimize the configurations. To be able to only use the ETX values of the links Equation 13 is used. With this equation the end to end packet reception ratio is estimated and this formula is also used to see the impact of the retransmissions on the end to end packet reception ratio.

$$\text{End to end PRR} = \prod_{\text{Link } i \text{ on the path node-sink}} \text{PRR}_i$$

Equation 18 End to end packet reception ratio

Combining the constraints from QoS with Equation 14 and Equation 11 will give the requirements the configuration should match. Finding the optimal solution for which the load on the nodes is lowest can be done using solvers like for MS solver foundation or excel solver.

When creating a configuration framework for a network, the stability of the framework is a concern. The framework should not overcorrect for a certain situation, leaving a network where too many retransmissions and duplications are used in order to ensure the reliability of the nodes. With this approach this will not occur.



An unstable framework can occur when the inputs, the ETX and RSSI values, and the outputs, the transmission power, retransmissions and duplications, influence each other. This means that by changing for example the number of retransmissions the ETX value would change. For the retransmissions and duplications this is not the case. However the transmission power and the RSSI are strongly related, in fact they are one-to-one related. Thus to maintain stability the transmission power should not overcorrect when changing the configuration. Since the transmission power and RSSI are so strongly related, it is very predictable what effect the change of the transmission power will have on the RSSI value, and therefore overcorrection is unlikely to occur.

Another possible instability is whether changing the transmission power can cause the ETX value to change. This is also a possible cause for instability of the framework. However when the transmission power is decreased the remaining RSSI value will remain above the -85 dBm. From earlier analysis of the network it is known that lowering RSSI value to -85 dBm will barely have any influence on the quality of the link and thus the ETX. Thus the relationship between the transmission power and the ETX will also not be a cause for an instable framework.

### 4.3.3 Examples of reconfigurations

To make the options for configurations clear this section gives a few examples to explain the different problems and solutions for reconfiguration.

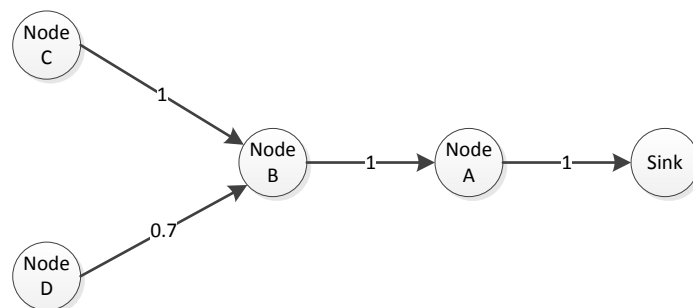

Figure 19: Example network for configuration

Figure 19 shows an example network of 4 nodes and a sink, with edges labelled with the link PRRs. In this network only node D will not deliver 100 % of its packets and let's say that the required reliability is 90% and all nodes have the same sensing period. Now either duplications for node D or retransmissions on the link between node D and node B are required to get the required reliability. Both will have the same impact on the reliability of Node D.

When duplications are used multiple instances of the same packet can propagate through the network and the load on the nodes B and A are increased. When retransmissions are used instead of duplications only the link between node D and node B will have an increased load and the rest of the network would not notice it. In this situation retransmissions should be preferred over duplications. When the period and reliability requirements of all nodes are equal retransmissions will always be preferred over duplications.

In the following example a larger network with different link qualities is used, see Figure 18.

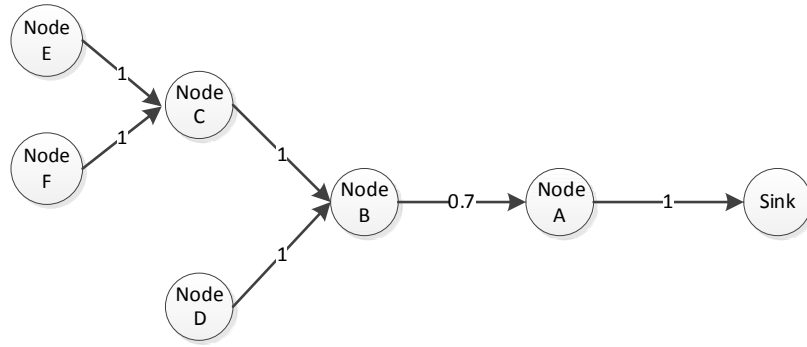

Figure 20: Example network 2 for configuration

In this example the sensing periods of all nodes except node D are 1 packet per second and the reliability requirement is 85%. For node D the requirement is to deliver once per 8 seconds a packet with 95% reliability.

The load on the nodes is now without duplications and retransmissions

| Node   | Load in packets   |
|--------|---|
| Node E | $1/1 + \text{Load children} * \text{link PRR} = 1$                          |
| Node F | $1/1 + \text{Load children} * \text{link PRR} = 1$                          |
| Node C | $1/1 + \text{Load children} * \text{link PRR} = 1 + 1 + 1 = 3$              |
| Node D | $1/8 + \text{Load children} * \text{link PRR} = 0.16$                       |
| Node B | $1/1 + \text{Load children} * \text{link PRR} = 1 + 3*1 + 0.125 * 1 = 4.16$ |
| Node A | $1/1 + \text{Load children} * \text{link PRR} = 1 + 4.125*0.7 = 3.89$       |

When optimizing this network for the minimum total load of the network node B should be configured using 1 retransmissions and node D with one duplication. This will result in Table 2 showing the load on the network, and the corresponding reliabilities.

| Node   | Load in transmissions per second over link | Reliability |
|--------|--|-------------|
| Node A | 4.8  | 1           |
| Node B | 5.2  | 0.91        |
| Node C | 3  | 0.91        |
| Node D | 0.25                                       | 0.99        |
| Node E | 1  | 0.91        |
| Node F | 1  | 0.91        |

Table 2: Network load en reliability after reconfiguration

The complete load of the network becomes 15.6 transmitted packets per second and all reliabilities are matching the requirements. This example shows the use of duplications and retransmissions related to the QoS requirements of the nodes, and that the optimum can be found combining both. Duplications will be used when the node that has a weak downlink or one of its children has a higher reliability constraint than the other. By increasing the number duplications on that node could prevent unnecessary high retransmissions, and could lead to a lower load on the network.

## 4.4 Verification of the analysis and configurations on real deployment's

To see how the theory described previously in this document on analysis and configuration of wireless networks data from a number of deployments were taken into account. The deployments were carried out in two locations over a period of multiple days to see how they behave and whether this matches the previously described expectations. The analysis of the deployments is made in this section.

The first location contains a deployment where 8 nodes are used to create a communication network over multiple floors of an office building in Grenoble. In the second deployment 10 nodes are used to create a sensing network in the Nimbus building in Cork.

Both deployments contain a small number of nodes but this is also due to the small size of the buildings. The use of more nodes would have led to a denser deployment where the routing protocol is able to find high quality routes and the network is likely not to drop packets Therefore relatively small sized deployments were chosen.

### 4.4.1 The Grenoble deployment

In Grenoble multiple test deployments were executed as part of the EU FP7 SCUBA project . And the data of this deployment has been made available for analysis. A number of configurations were deployed in the same building over 2 floors using 8 nodes and a gateway. All deployments were carried out in the same building across two floors. To demonstrate the analysis capabilities of the proposed framework, this section will present the evaluation of two configurations in terms of the quality of the deployment.

#### 4.4.1.1 Deployment 1

The map of the first deployment is illustrated in Figure 21.

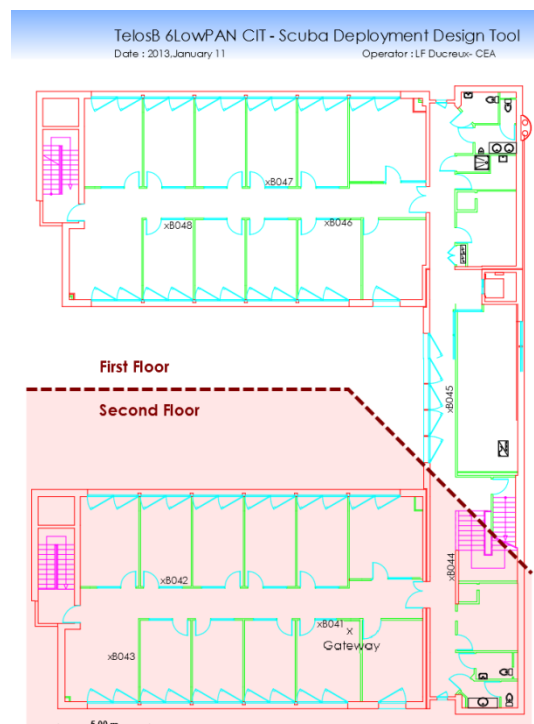

Figure 21 Map of deployment 1 in Grenoble

The deployment covers two floors of the building. The nodes x0b44 and x0b45 connect the different floors. Thus the connections between those two nodes and the connection of x0b44 to the gateway are crucial for all the nodes on the first floor, since all packets from the first floor will be sent over these links. The standard configuration used to deploy networks is to transmit at full power and to use at most 2 retransmissions per packet. This is a pessimistic approach but it is good to use it as a starting point. When there are links of a lower quality the network is still likely to be able to transmit its data over this link.

A first look at the average end-to-end PRR and ETX values of the links as described in 4.1.2 and 4.1.3 is presented in Figure 22. This is for all nodes over the complete deployment period and shows that node 0b45 lost 4% of its packets, and the other nodes on the first floor 0b47, 0b48 and 0ab46 lost almost half of their packets. From this, it is likely that a fraction of the data is lost on the link between 0b45 and 0b44, but that the link between 0b47 and 0b45 is of a worse quality.

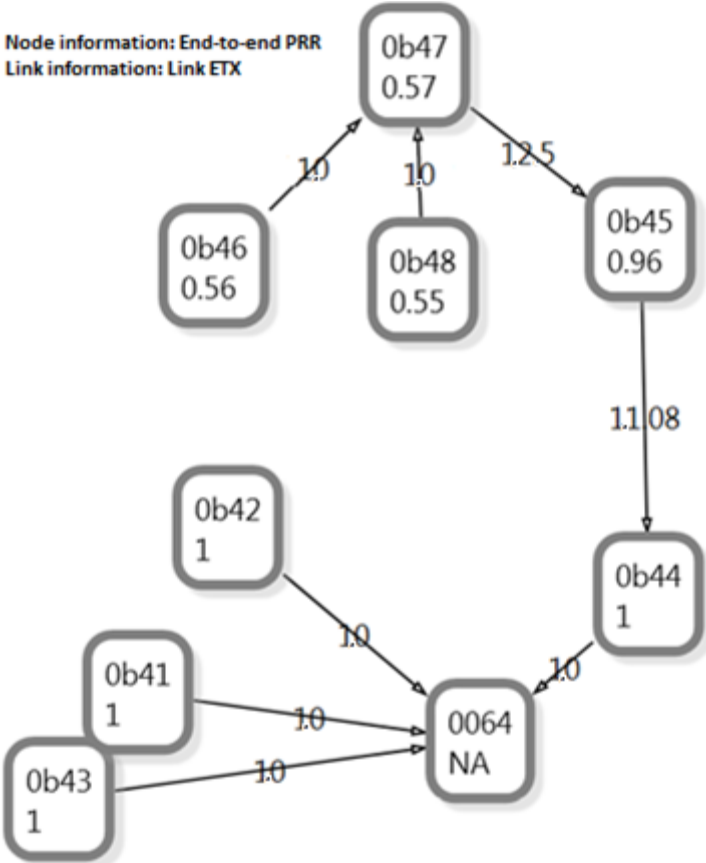

Figure 22 Packet reception ratios of deployment 1 in Grenoble

The ETX numbers are matching that analysis. The more packets were lost on the links the higher the ETX values are. The last step of the analysis is to match it with the RSSI values. From section 4.1.2 we know that it is possible to derive the packet reception ratio from the ETX values.

$$PRR \text{ link } 0b45 - 0b44 = \sqrt{\frac{1}{ETX}} = \sqrt{\frac{1}{1.108}} = 0.96$$

$$PRR \text{ link } 0b47 - 0b45 = \sqrt{\frac{1}{ETX}} = \sqrt{\frac{1}{1.25}} = 0.89$$

Doing this shows us that the actual measured packet reception ratio on the link 0b45-0b44 is a match with the actual packet reception ratio. However the other link 0b47-0b45 the calculated packet reception ratio does not match the nodes packet reception ratio. The estimated packet reception ratio of the node 0b47 is 0.77 and the packet reception ratio of the node equals 0.57.

$$Packet\ reception\ rate = \prod_{Link\ i\ on\ path\ to\ sink} PRR_i = 1 * 0.96 * 0.8 = 0.77$$

There is a good explanation for the difference in those two numbers. When measuring the link ETX the sink is dependent on the arrival of the packets from the node. When over a longer period no packets arrive a new ETX value is unknown while the link is of a lower quality. When using the average over the entire period and only values of lower quality are missing, the result will become too optimistic. It is therefore recommended that when using the metrics from the network, a small period of time should be evaluated to reduce this impact.

Next to the packet reception ratio and link ETX values the RSSI is a good link quality indicator. The average RSSI value of the link between 0b45 to 0b44 is -83 dBm. This should be sufficient to maintain a good quality link. But when looking at the plot of the RSSI value over time, Figure 23, it becomes clear that during the day the signal strength is lower than during the night times. The same pattern is expected for the link 0b47 to 0b45, but when a link that is at -90 dBm degrades further the connection is lost and no new readings are obtained by the sink. It can be concluded that the behaviour of the network is flexible since the values of the RSSI can vary by 5 to 10 dBm. Thus, when using the configuration framework, the re-evaluation of the configuration should be a continuous process. A single configuration for a deployment will not be sufficient, as the dynamics of the network is too high.

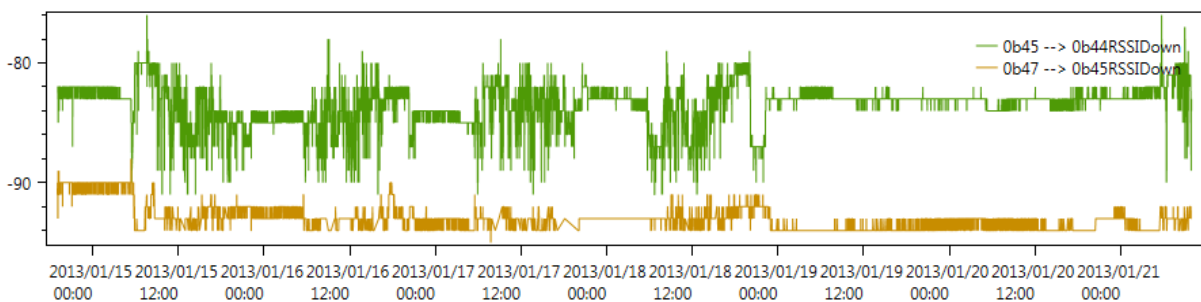

Figure 23: RSSI plot of deployment 1 in Grenoble

#### 4.4.1.2 Deployment 2

For the second configuration the node which was located close to the base station was moved to the first floor in order to create a more robust connectivity in that area, which should improve the delivery of packets to the sink. The second deployment is illustrated in Figure 24.

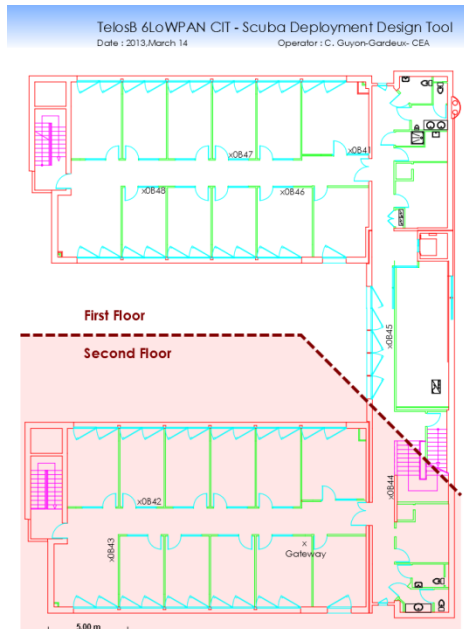

Figure 24 Map of deployment 2

The most used links of the deployment, the node packet reception ratio and RSSI values are illustrated in Figure 25.

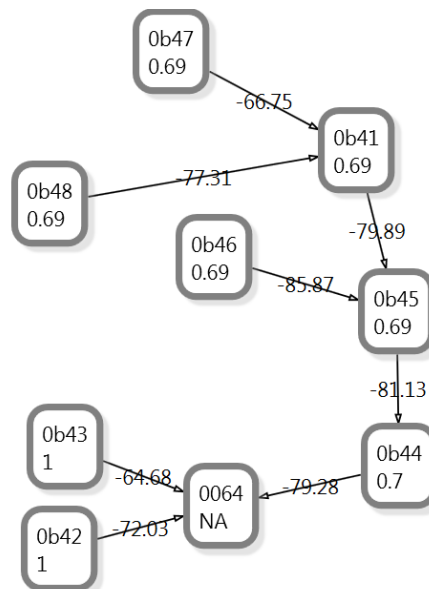

Figure 25: Deployment 2 RSSI and end-to-end PRR

A remarkable thing from this redeployment is that the node 0b44 is now losing 30% of its packets whereas in the first deployment the exact same location of the node was used and during that time period no data was lost. All other nodes that rely on this node to forward their data show the same losses, it is very likely that these losses are caused by the inability of node 0b44 to reach the sink. The RSSI value of 0b44 is -79 dBm and does not indicate the possibility of a bad link. Normally links with this value would be able to operate at a high quality.

To further investigate the cause of this link failure the end-to-end PRR and RSSI is plotted. This value is calculated by a 50 points moving average window and is illustrated in Figure 26.

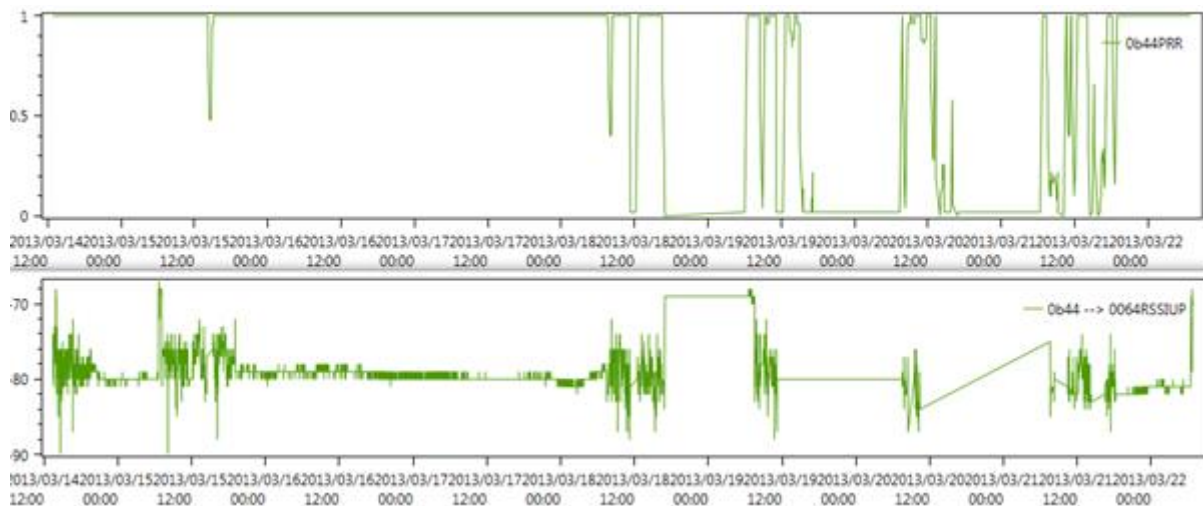

Figure 26 RSSI and end-to-end PRR of node 0b44 in deployment 2 in Grenoble

What this figure shows is that the node when it is able to deliver its data to the sink can do this for all its packets. But at some time periods the quality drops and no packets can be delivered at the sink. Thus the link quality is 100% or 0%. When looking at the RSSI values there is no indication of a degrading signal strength. However the problem with the analysis based on data delivered at the sink is that only when the quality of the link is good data is received, and thus the situation of the link under bad circumstances is unknown. However from the previous analysis it can be concluded that since the connection is completely lost during these periods the RSSI values have to be dropped below the -90 dBm.

One possible cause of this link failure is that the environment changes, for example a door which opens and closes. When the door is open the link is good and when it closes it absorbs too much signal power to successfully reach the sink through the door. However since this deployment is done in a remote location and the changes of the environment are not recorded it is extremely difficult to identify the cause of the periods of connectivity loss.

Next to the problem with the node 0b44 reaching the sink the links of the nodes on the first floor are of interest. Those nodes had a bad quality in the first deployment but now these problems are solved. When looking at the end-to-end PRR the nodes on the first floor they all show the same quality and the plot of the packet reception ratios; Figure 27, shows that almost all packets are lost in the exact same periods as when the node 0b44 couldn't reach the sink, suggesting that the loss occurs while that node is forwarding the data.

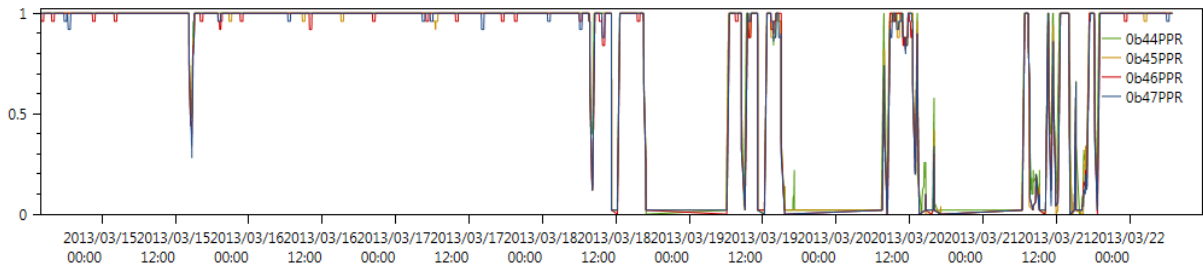

Figure 27: Packet reception ratios of all nodes on the first floor deployment 2 Grenoble

What can be concluded from this deployment analysis is that analysing the network is not straight forward. Using the analysis tool a summary of the performance is given, however due to the dynamics of the network this summary will not perfectly reflect how the network is behaving. However, the in section 4.1 described metrics to analyse the network do reflect the network qualities at specific moments in time. Thus analysing the network can be done using these metrics only the dynamic aspects of the network should be taken into account.

#### 4.4.2 The Nimbus deployment

For the Nimbus deployment, 10 nodes were used and dispersed across a single floor. To see if those nodes could create a fully connected network the deployment tool was used. After deployment the analysis was made and reconfiguration of the nodes was suggested and implemented. All steps are discussed in this section.

##### 4.4.2.1 The initial deployment:

As a starting point 10 nodes and a single sink were spread over the first floor of the Nimbus building. To ensure connectivity, the deployment tool was used. The output of the deployment tool is illustrated in Figure 28.

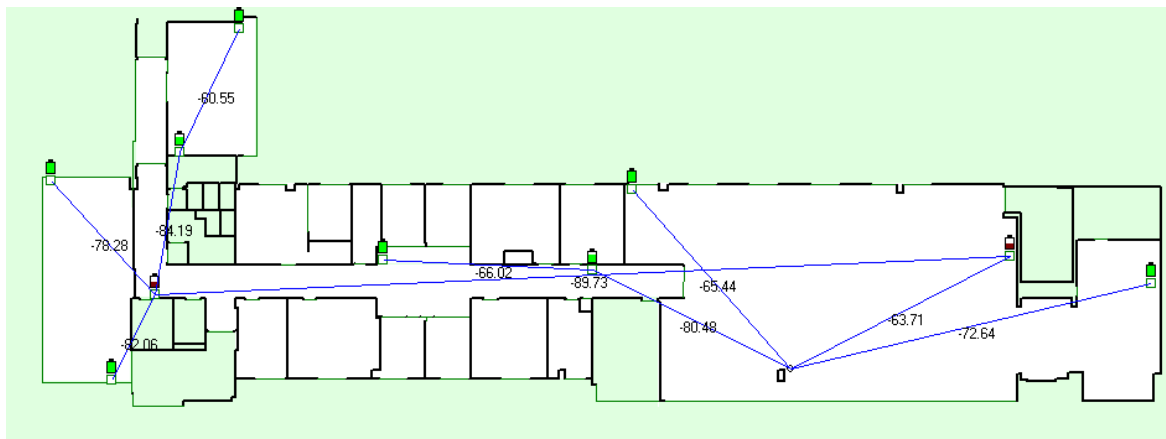

Figure 28: Topology and link quality estimation of deployment tool

According to the tool all nodes will be connected to the sink. Therefore, this will be the physical deployment which is used for the tests. As a starting point, all nodes are configured at maximum transmission power and two retransmissions.



#### 4.4.2.2 Analysing the deployment

The deployment ran for one day. This should be enough to get a first impression of what the link qualities are and to see what new configuration can be derived from the deployment information. The packet reception ratios and RSSI values are illustrated in Figure 29.

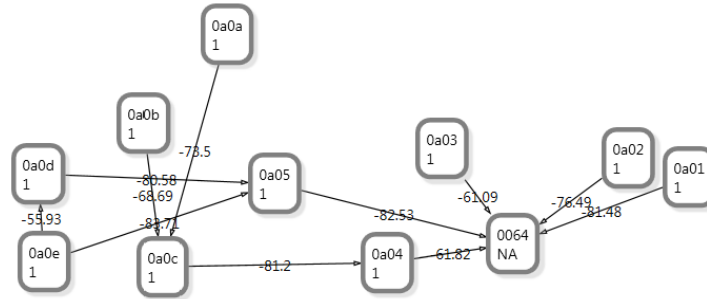

Figure 29: Packet reception ratios and RSSI values of deployment 1 in Nimbus

As this figure shows, all nodes managed to deliver 100% of their packets, and no links had signal strengths lower than -85 dBm. Based on this initial deployment a reconfiguration is determined which will optimize the lifetime of the network without compromising its quality.

#### 4.4.2.3 The reconfiguration

As described in subsection 4.3 is reconfiguration done in two parts. The first part is to determine the transmission power settings of the nodes and after that the number of duplications and retransmissions are determined.

To determine the transmission power of the nodes the current signal strength values are important. When lowering the transmission power the remaining signal should remain more than -85 dBm. Thus the following table shows for each link the RSSI values of the worst connection. The worst connections of each node is enough for the analysis since as shown in the section 4.3.1 all incoming and outgoing links from a node should remain higher than -85 dBm when lowering the transmission power. Thus only looking at the worst link is enough.

| Node | Worst RSSI value | Check -15 dBm<br>Value -15 > -85 | Check -7 dBm | Check 0 dBm |
|------|------------------|----------------------------------|--------------|-------------|
| A01  | -81              | False                            | False        | true        |
| A02  | -76              | False                            | False        | true        |
| A03  | -61              | True                             | True         | true        |
| A04  | -81.2            | False                            | False        | true        |
| A05  | -82              | False                            | False        | true        |
| A0A  | -73              | False                            | True         | true        |
| A0B  | -68              | True                             | True         | true        |
| A0C  | -81.2            | False                            | False        | true        |
| A0D  | -80              | False                            | False        | true        |
| A0E  | -55              | True                             | True         | True        |

Table 3: Transmission power checks

Based on Table 3 the conclusion can be made that the transmission powers of nodes A01, A02, A04, A05, A0C and A0D should remain unchanged. The transmission powers of then nodes A03 can be lowered with 7 dBm and A03, A0C and A0E with -15 dBm without compromising on the link qualities.

Determining the number of retransmissions and duplications is easy in this situation. Since all nodes delivered 100% of their packets, no duplications and retransmissions need to be used.

#### 4.4.2.4 Deploying the reconfigured deployment

After all nodes were reprogrammed and put back on their positions the network should start rebuilding the network. However the test bed is only tested on a single configuration this configuration is that all nodes use the same transmission power and 2 retransmissions. For other configuration no extensive testing and debugging was done yet. Now that different transmission powers are used in the same network, building the routing tables does not work properly.

All nodes which can reach the sink in a single hop where successfully connected to the sink. But for example node AOC which used node A04 to forward its packets does not connect anymore while those nodes are still using full transmission power. Since the transmission power has not changed those nodes should still be able to connect to each other and form a network. The reason why this isn't happening is not clear.

Due to the issues regarding rebuilding of the network no data could be retrieved to verify the quality of the network after reconfiguring the nodes. Since part of the assignment was to use the test bed as is, verification of the framework is challenging.

#### 4.4.3 Problems with the wireless sensor network test bed

As the previous section already stated challenges regarding the use of test bed in different configurations raised. During the tests I have performed, three types of unexpected behaviour where found. These types regard the use of the network with nodes using different transmission power setting, node that use no retransmissions and links that come close to a connectivity loss. All three are described here.

##### 4.4.3.1 Multiple transmission powers in a single network

The issue with multiple transmission powers in a single network concerns the creation of routes in the network. This issue can be explained using two nodes and a sink of which one node is using a lower transmission power, node A. The other node, node B, and the sink will use the same higher transmission power and are both able to transmit packets to the node with the lower transmission power. However Node A due to its lowered transmission power is unable to transmit data to the sink. This situation is illustrated in Figure 30.

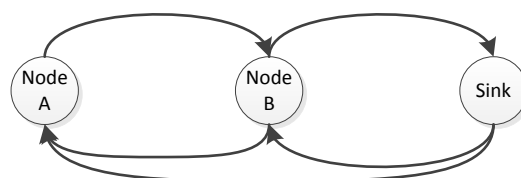

Figure 30: 3 nodes connectivity problem

Node A would preferably connect to the sink instead of connecting through node B. However, this connection is not possible since node A is using a lower transmission power and it therefore unable to reach the sink. But what I think that will happen is that node A receives messages of the sink and that it thus assumes that the sink is within range of node A. This causes node A to try to send its packets directly to the sink whereas it due to its lower transmission power is unable to reach it. This

leaves node A unconnected while it could connect to the network using node B. I ran into this multiple transmission power problem multiple times and in different configurations and locations and the same pattern was seen over and over again. My conclusion from this was that this test bed only supports a single transmission power level for each node.

#### 4.4.3.2 No retransmissions

The problem when no retransmissions are used is that the network does not measure its ETX according to its definition. No matter what the quality of the link is the ETX value will always remain 1 while it should indicate the quality of the link. To illustrate this I placed a node at a location where during the night the link was of a good quality and during the day packets were lost on the link. This node is directly connected to the sink thus only one link is involved in the communication. Both the packet reception ratio and the ETX value are plotted in Figure 31.

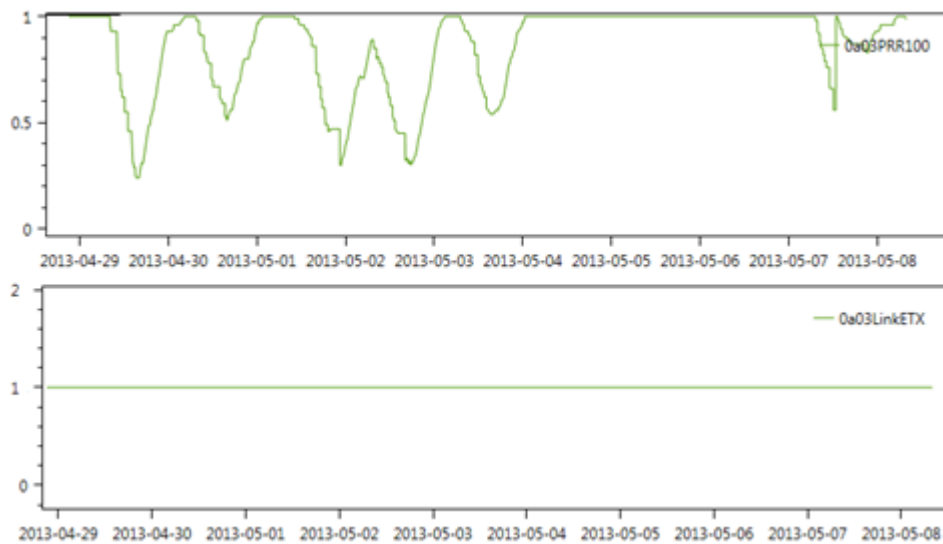

Figure 32: Packet reception ratio and ETX of a weak link with 0 retransmissions

As this graph shows, the end-to-end PRR drops to about 30% while the ETX remains 1. Since the ETX is related to the link quality it should show the same pattern as the end-to-end PRR. Using the ETX value to qualify the link quality becomes more challenging when this value cannot be used when a no retransmissions are used the link.

Next to analysis of the links, also the network itself will suffer from this. The routes in the network are determined based on the ETX values. When those values will not reflect the actual link qualities the network is unable to determine which routes lead to a strong topology and it will always select the shortest route independent of the quality of the links.

My hypothesis is caused by the fact that the ETX values are measured depending on the configured number of retransmissions on the nodes. Thus the ETX reflects the probability that a packet is successfully transmitted of the link in the current configuration. Thus the higher the number configured retransmissions the lower the ETX value will be. This suggests that the ETX value is also determined based on how often and how many retransmissions are used to send a packet over the link, but when a node is configured not to use retransmissions it will never use one and thus no increase in ETX will be measured since each packet will only be transmitted once.

#### 4.4.3.3 *Low quality links with retransmissions*

The last problem that I have encountered occurred in the situation when a node connects to for example the sink and there are no other nodes to use to forward the node's data. The used location of the node is the same as in the previous problem description only now 2 retransmissions are used. Since the number of transmissions per packet is increased I would expect that the node is able to successfully deliver more of its packets and to see variation in the ETX values. However the node disconnects itself after a couple of minutes and does not reconnect to the sink. When moving the node closer to sink, and the link quality increases it can reconnect. When moving the node back to its old position results again in an active link for a couple of minutes after which it disconnects again.

What I think causes this is that a node uses a threshold value after which it assumes that the link is of a too bad quality to use and disconnects from the link. When there are no other links to connect to the node remains unconnected to the network. The link quality is measured in ETX and I think that a threshold is set on the ETX value. This idea is strengthened by the fact that when placing a node at the same location using no retransmissions, which causes the node to use a constant ETX value of 1, the node keeps its connection regardless of the quality of the link. However when increasing the number of retransmissions on the node it disconnects from the network.

### 4.5 **The analysis tool**

When a network is deployed and the data collection is in progress the analysis on how the network is operating is the next step. To create this the presented framework was encapsulated within a software tool to aid in the analysis post-deployment. This tool should help the network engineer to easily see how the network is operating providing information such as what topology is used, what is the connectivity of the nodes and what is quality of the links on a link and physical level.

In order to easily analyse a network the visualisation is one of the important aspects. Therefore the network will be displayed as a directed graph  $G = (V,E)$ . In this graph, the vertices represent the nodes and the edges the links between nodes. Using this technique the used topology during a pre-selected interval can be visualised and this can be combined with information of the different metrics in the network. A screenshot of the tool is given in Figure 33.

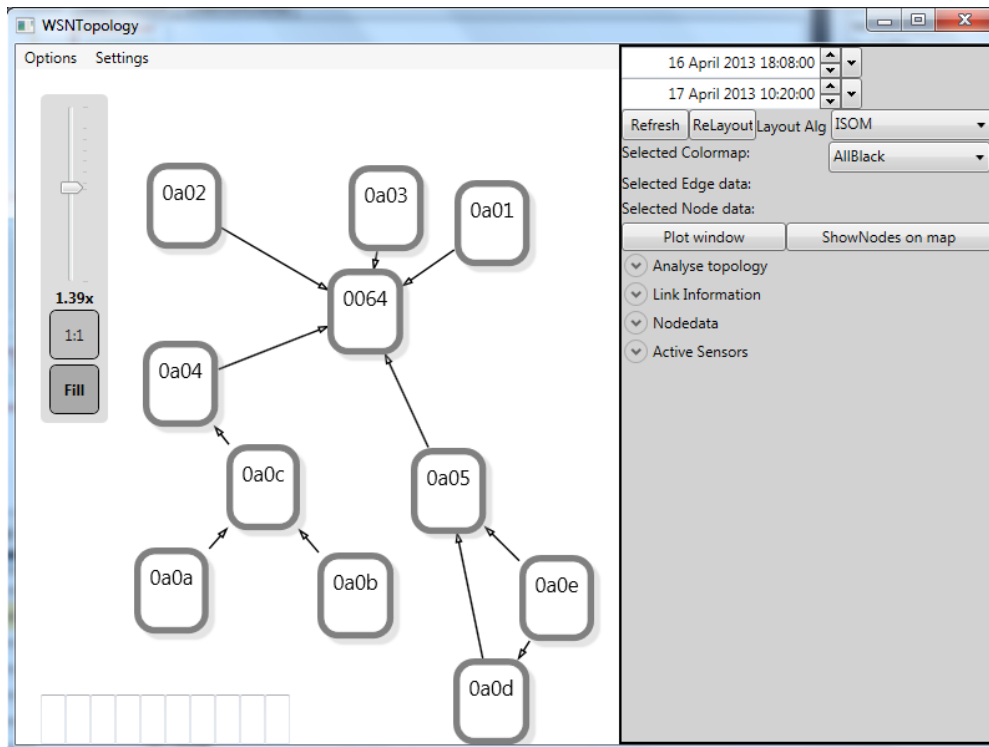

Figure 33: Analysis tool

The tool can be divided into the following main elements:

- The visualisation
- The period
- The topology
- The node information
- The link information
- The sensor types
- Graph window

Those 7 elements are described in this section.

#### 4.5.1 The visualisation

In this window the directed graph is displayed, and the user is able to navigate through the network by moving the nodes around on the screen, zooming in and out. This section is also used to select nodes and edges to obtain more information about that specific node or edge.

The topology which is displayed is constructed based on the information generated by the network. The statistics packets contain a data field in which a node reports the address of its parent. All those data fields of all nodes are used during the generation of the network. When a node uses multiple parent within the period of period multiple outgoing links will be drawn for that node. For example node 0a0e in Figure 33, used both a0d as a05 as its parent.

#### 4.5.2 The period

To select the period a start and end time setter are used. The first one specifies the start time and the second one the end time. This time is used to query the database and thus the analysis for the network will be done based on the selected time period.

#### 4.5.3 The topology

During the selected period the topology could change over time. This might result in a network where nodes have several down links and the actually used topologies cannot be extracted from the first summary of the by the network used topologies. It could be interesting to see what topology is used at what time and how the topology develops over time.

Next to only visualizing the used topology at a certain time point only showing the most used link from each node might give a better understanding of the network.

The menu to control this is illustrated in Figure 34.

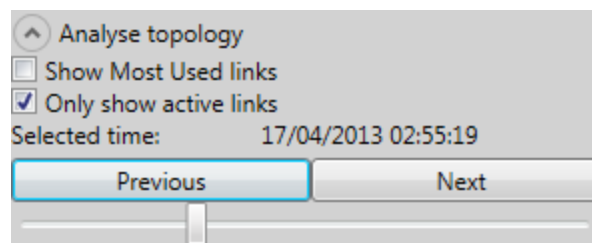

Figure 34 Topology analysis interface

When looking at the deployment based on time there are two options to select a topology. The first option is to step through the various used topologies by clicking on the next and previous. The way the sequential development of the topology can be analysed. When a more specific time is of interest the scroll bar can be used to scroll through time and select a specific time point.

This function should give the network engineer the opportunity to analyse a highly dynamic network. It should help to see how the network changes over time, and what topology dynamics are occurring. Using this function links of interest can be separated from those which are not important for the network.

#### 4.5.4 Node Information

The nodes send data to the sink for analysis. The information of each node is aggregated and attached to node in the visualization. By selecting a node from the topology the information will be displayed in this section. The information is divided into different boxes. Each tap will contain its own type of information. The 4 taps are:

- Node QoS
- Node statistics
- Node sent packets counters
- Others

All statistics from can also be used to select any data type which should be displayed in the nodes in the visualisation. This way the values of all nodes of a specific statistic can easily be compared. In Figure 35 an example of the node data window is shown.

| Type                      | Value | Relative Value |  |
|---------------------------|-------|----------------|--|
| Node:                     | 0a0e  |                |  |
| NrOfPacketsSent           | 1194  | 0              |  |
| NrOfPacketsReceived       | 165   | 0              |  |
| NrOfPacketsForwarded      | 0     | 0              |  |
| NrOfDataPacketsSent       | 1092  | 1              |  |
| NrOfSensorPacketsSent     | 911   | 0.76           |  |
| NrOfStatisticsPacketsSent | 181   | 0.15           |  |
| AdvTx                     | 67    | 0.06           |  |
| SolTx                     | 35    | 0.03           |  |

Figure 35: Node data window

Those four types are further discussed here.

#### 4.5.4.1 Node QoS

The node QoS matches the given quality of service requirements with the measured behaviour of a node. The user can predefine the required quality of service of each node. Then the tool will match this requirement with the actual performance of the node and sees if the node is operating according to those requirements. The only quality of service metric which is analysed at the moment is reliability as described in 4.2.2.2 and added to that will the longest period of consecutive packet loss be showed here. This however can later be extended when lifetime and latency analysis are made. This metrics represents the amount of data that is received at the sink. Later when the network is further developed this can be extended with for example lifetime and latency.

#### 4.5.4.2 Node statistics

The node statistics give information about how the node is performing, and what it did in the period. Information like the average packet reception ratio, number sensor/statistics packets sent and the average ETX of the uplink are given in this. This list of information is a small summary of how active the node was.

The metrics shown here are:

- Number of missed packets: the number of packets a node sent to the sink but did never reach it.
- Number of used link: the number of different down links the node used
- Link ETX The average value of the downlink during the period
- Estimated link quality: the estimated link quality based on the ETX corrected for the number of retransmissions used.

#### 4.5.4.3 Node sent packets counter

The activity of a node can be analysed based on counters which are embedded in the statistics packets. The number of for example sent sensor/statistics and routing packets are summarized in this tap .

The statistics available in this tab are:

- Nr of packets sent, this is the number packets created by the node itself.
- Number of packets received, the number of routing and configuration packets received by the node
- Nr of packet forwarded, this is the number of packets that are successfully sent to a node and that it forwarded to its parent.
- Nr of data packets sent, this is the sum of sensor, statistics and routing packets is the number of data packets sent by a node
- Number of sensor packets, this is the absolute and relative number of sensor packets a node sent. The relative value is relative to the number of data packets sent.
- Number of statistics packets, this is the absolute and relative number of statistics packets a node sent. The relative value is relative to the number of data packets sent.
- Router solicitation sent, this is the number of times a node requests other nodes their network status. This is done when re-evaluating its parent.
- Router advertisements sent, this is the number of times a node responds to router solicitations of other nodes

#### 4.5.4.4 Others

When extra sensors are added for examination of the deployment, the average value and deviation of the dataset can be found on this tab.

#### 4.5.5 The link information

The edge information has the same purpose as the node information. It should give the user a summary of the information available for the link. Just as on the node is the information on the link also divided into multiple tabs. The available tabs are:

- List statistics
- Link indicators

Just as with the node information can the all metrics in the different tabs be used to display on the edges in the visualisation to compare the different values of all edges. Figure 36 shows an example of the link information window.

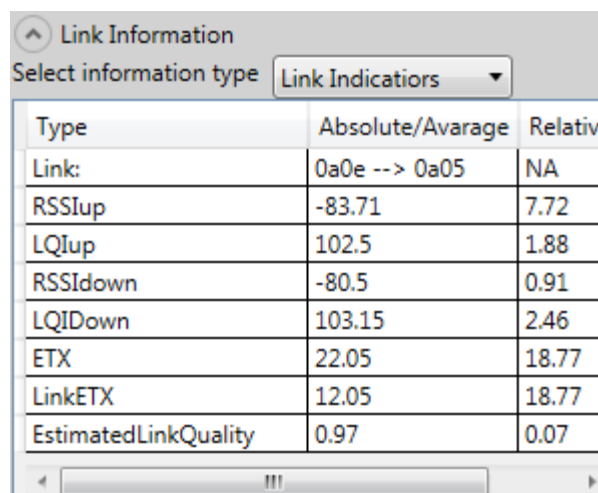

The screenshot shows a window titled "Link Information" with a dropdown menu set to "Link Indicators". Below the menu is a table with three columns: "Type", "Absolute/Average", and "Relative". The table contains the following data:

| Type                 | Absolute/Average | Relative |
|----------------------|------------------|----------|
| Link:                | 0a0e --> 0a05    | NA       |
| RSSIup               | -83.71           | 7.72     |
| LQIup                | 102.5            | 1.88     |
| RSSIdown             | -80.5            | 0.91     |
| LQIDown              | 103.15           | 2.46     |
| ETX                  | 22.05            | 18.77    |
| LinkETX              | 12.05            | 18.77    |
| EstimatedLinkQuality | 0.97             | 0.07     |

Figure 36: Link information window



#### 4.5.5.1 *Link statistics:*

The link statistics yield some basic numbers on of the link. This contains statistics like load, number of packets over the link absolute and relative to the number of packets sent by the node or how many packets a the node missed using that link.

The statics are:

- Estimated load in p/s.  
In section 4.3.2 a method is described to determine the load in packets per second on each link is described. This method is used to determine the load on each link
- Number of activations.  
This number indicates how often the node switched to that specific link. And is given in an absolute and relate to the total number of link changes number.
- Nr of missed packets.  
An absolute and relative to the total number of transmitted packets number indicating how many packets where lost on that link
- Number of packets over link.  
An absolute and relative number indicating the number how many packets where transmitted. The relative number shows how much per cent of packets where transmitted over that link

#### 4.5.5.2 *Link indicators*

The link indicators section contains the metrics that are used in section 4.1 to analyse the network.

The used values are:

- RSSI up average and deviation
- LQI up average and deviation
- RSSI down average and deviation
- LQI down average and deviation
- ETX average
- Link ETX average and deviation
- Estimated link quality based on the link ETX and configuration

#### 4.5.6 **The sensor types**

Next to the analysis of the standard network indicators is can also all other types of sensors which are on the nodes be added to the analysis. Sensors like for example the temperature can be selected to be included in the analyses and then will the average and deviation be added to the The nodes information. Also the graphs of those sensors can be plotted in the plot window. Figure 37 shows the sensor selection window.

| Optional sensors | Selected sensors |
|------------------|------------------|
| par              | temperature      |
| FWDrop           | voltage          |
| RXTTotal         | humidity         |
| ENCFail          |                  |
| Rcvd             |                  |
| Checksum         |                  |
| SolRx            |                  |
| AdvRx            |                  |

Figure 37: Sensor selection window

#### 4.5.7 Graph window

All the previously described data are either absolute average or relative values over the complete period. This can give a good first understanding of the network. However to get real insight in the dynamics of the networks time graphs are important. These graphs can show the different links or nodes perform over time. To show these graphs a different window is created. This window is illustrated in Figure 38.

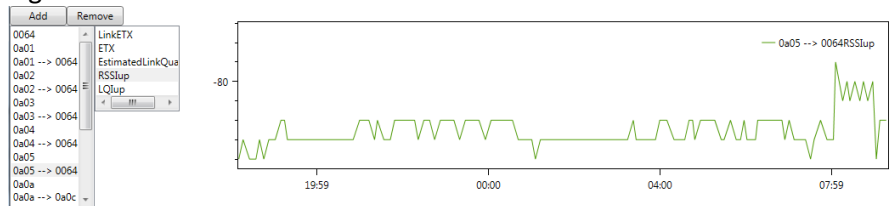

Figure 38: Plot window

This window contains 2 columns. The first one contains a list of all nodes and edges. When selecting a node or edge all the available plots will be listed in the right window. By selecting a instance in both columns the requested plot can be selected and added by the add button. So the dynamics of the network can be further examined.

## 4.6 Conclusion

The central question for this chapter was: Once a wireless sensor network is deployed what information can be extracted from the active deployment for analysis, and can this information be used to (re)configure the network?

This question could only partially be answered. Analysing the wireless sensor network can be done based on the information the network supplies. However analysing a network involves more than looking at just a single moment in time. Wireless sensor networks tend to have a dynamic behaviour making it hard to analyse the network over time. Single links at certain moments are easy to analyse, but analysis of the changing topology combined with variations in link quality is challenging.

When analysing the network this should be done in three layers. First the transport layer, this analyses the connectivity of a node with the sink independent of its location in the network. Second the link layer. This layer looks at the quality of the links used in the network based on the probability that a packet is successfully transmitted over the link. And the third layer is the physical layer. This layer checks the signal of each link which is used for communication.

In order to make the analysis of a network easier an analysis tool is developed. This tool visualises the topology of the network. Within the visualisation, aggregations of all metrics which are sent by

the nodes to the sink can be visualised on the nodes or links. Next to the aggregations, the plots of all metrics can be created; this makes analysing the network easier.

When the network is analysed the performance of the network is better known. This knowledge of the performance is used to see if the network's configuration can be derived from these analyses. The relation between the metrics and the behaviour of the network is used to determine the required configuration for the specified quality of service of the network.

In order to test the derived configurations a test setup was made using the Nimbus wireless sensor network test bed. However this test bed was only tested in a single configuration setting and caused failures in other configuration settings, like for example when the nodes were using different transmission powers, the network is unable to operate in a normal way which caused the configuration method to be untested.

## 5 Linking the Deployment to the Design

The previous sections considered what information could be extracted from the network to evaluate the performance of a network once deployed. This section will consider what can be taken from the network and feed back to the design phase in order to support a system integrator when evaluating changes in the deployment (i.e. node positions). As was stated previously the design can only provide an estimate of connectivity however due to changes in the environment it is very difficult to know if this is reflected in reality and if not then can it be improved from analysing the network connectivity.

For the initial design using the deployment tool the floor plans of a building are given as input and used to estimate the propagation of the signals within the environment. This enables a user to design without any physical measurements at a building offering a great advantage because now a design can be made without visiting the building. The downside is that since only limited knowledge of the building is used the quality of the design might not be sufficient for the application.

This section will focus on how the models used to predict the signal propagation and whether it can be adjusted using the network data. This information can either be a site survey or the output from a deployment. Both will contain data about the signal attenuation between a transmitter and receiver. This data is then compared to the estimated values and the differences can be used to improve the estimation model.

At the last week of my research information which was unknown to me raised. This information would have led to other approaches to improve one of the models (ray tracing model). However due to the late notice I was not able to process this new information and conduct a proper research using this. Therefore the described method regarding the ray tracing model will probably not be implemented, but since this thesis should also describe my work I left it in there.

Different models for signal estimations exist. The two most commonly used are the multi wall model [23] [24] [25] and the ray tracing model [26] [27]. The ray tracing model is currently being used by the design tool but it also can use an optimised version of the multi wall model after a detailed site survey. For both models the theory and how they can be used to improve the prediction quality for the design tool will be explained.

### 5.1 The multi wall model:

The multi wall model is an empirical model and used to predict the attenuation between a transmitter and a receiver. The model contains 3 components of signal loss. [24]

- Free space attenuation
- Distance attenuation
- Object attenuation

All those components will be described here.

#### 5.1.1 Free space attenuation:

The free space attenuation, also called  $PL(0)$  or path loss 0, is a static number of signal loss that is caused by the gain of the transmitter, receiver and the frequency of the signal used for propagation.

By definition the free space attenuation component is given by the loss of signal at 1 meter from the transmitter. The formula is given in Equation 19.

$$Pl(0) = 20 \log_{10}\left(\frac{4\pi}{\lambda}\right)$$

Equation 19: Free space loss multi wall model [25]

$\lambda$  represents the wavelength of the used signal. The wavelength of the used 2.4 GHz signal is 0.12491 meter. Filling in this parameter in Equation 19 gives a free space loss of 40 dBm.

$$Pl(0) = 20 \log\left(\frac{4\pi}{0.12491}\right) = 40.05dBm$$

This means that the signal loss at one meter distance from the transmitter is 40.05 dBm. Thus the best possible received signal power is 0 dBm maximum transmission power minus 40 dBm free space attenuation, which equals -40 dBm.

### 5.1.2 Distance attenuation

The second component is the propagation distance attenuation. This number represents the amount of signal that is lost between the transmitter and the receiver based on the distance between the two. This factor can be determined by Equation 20.

$$Distance\ loss = n * \log_{10}\left(\frac{d}{d0}\right)$$

Equation 20: Distance attenuation for the multi wall model

In this formula,  $d$  represents the distance between the receiver and the transmitter,  $d0$  is the unit in which the distance is measured and  $n$  the attenuation factor. This factor  $n$  should be tuned based on measurements in the building. The structure of each building is different and the signal quality is heavily influenced by the structure. Therefore this number can vary for each building.

To determine this value a site survey should be performed. A site survey means that at different distances and different locations within the building the signal strength is measured. These measurements are then used to determine the value for  $n$ .

### 5.1.3 Wall attenuation

The third component is the signal loss due to objects such as walls that intersect the direct path between the transmitter and receiver. Walls and other object are harder to propagate through, and should therefore be taken into account when estimating for the total loss factor. Those object types will have a constant attenuation factor. To determine the attenuation of propagating through walls a site survey just like for the distance factor is used.

The cost for propagating through walls can be determined at different levels. One cost factor that is equal for all walls, or get a cost factor per wall type when a building has multiple wall types for example, a heavy outside walls, glass walls or a lighter internal walls. To obtain a cost factor per wall can lead to a higher accuracy in the model but this has as downside that the required dataset to tune the costs for each wall should be much larger than to for the two other types. Thus it is a trade-off

between accuracy and the amount of data required as input for the model. The cost for the walls/objects is given by

$$\text{Object loss factor} = \sum_{\text{Object } i \text{ on the propagation path}} C_i$$

Equation 21 Object loss factor multi wall model

In this equation  $C_i$  stands for the cost of the object. This sum of all objects on the path should give a good estimation of the attenuation due to object on the path.

#### 5.1.4 Conclusion

Combining all elements gives Equation 22 to estimate the total signal loss on the path from transmitter to receiver.

$$Pl = Pl(0) + n * \log_{10} \left( \frac{d}{d_0} \right) + \sum_{\text{Object } i \text{ on the propagation path}} C_i$$

Equation 22: Multi wall model equation

The multi wall model applies this equation to estimate the signal strength between all communicating nodes.

In order to use this model a site survey at the building is required. Standard parameters can be used but as [28] describes the differences per building for both the wall attenuation and the distance attenuation can vary greatly. In [28] it was shown that the distance loss factor  $n$  could deviate from 18.1 in a grocery store to 32.7 in an office building.

## 5.2 The ray tracing model

The ray tracing model is a more advanced model than the multi wall model and is the model which is being used by the design tool to estimate signal strengths on links. The ray tracing model considers the distance and objects but also the physical properties of how wireless rays interact within the environment (e.g. reflection, diffraction, absorption). For example when a signal hits an object there is always a reflection of the signal. A part of the signal is reflected and another part is transmitted through the object. The angle at which a ray hits the object will also be the angle at which the reflection leaves the object. This is illustrated in Figure 39.

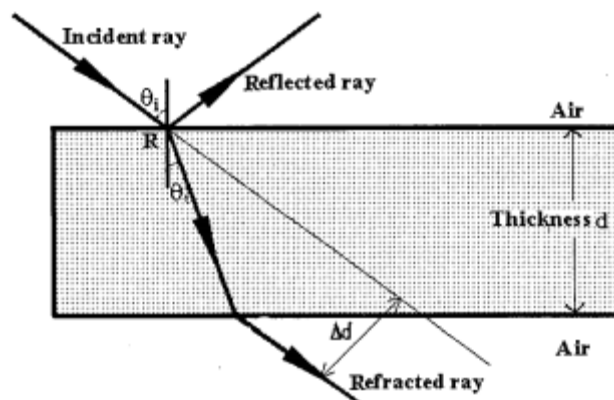

Figure 39: Reflection of a radio signal from [26]

Reflections could result in multiple rays from the same transmitter to arrive at a receiver. When the signals have travelled the exact same distance the time of arrival will be equal and the signals will strengthen each other resulting in a stronger signal. However when the different rays did not travel the exact same distance the two rays will be out of phase from each other. When two rays of a signal arrive at a receiver and they signals are in anti-phase of each other the quality of the signal shall significantly decrease or completely disappear. The relation between the phase shift and difference in time is related to the wavelength of the signal. Thus the shorter the wavelength, the faster the phase shift occurs. The effect of multiple rays arriving at a receiver in different phase shifts is illustrated in Figure 40.

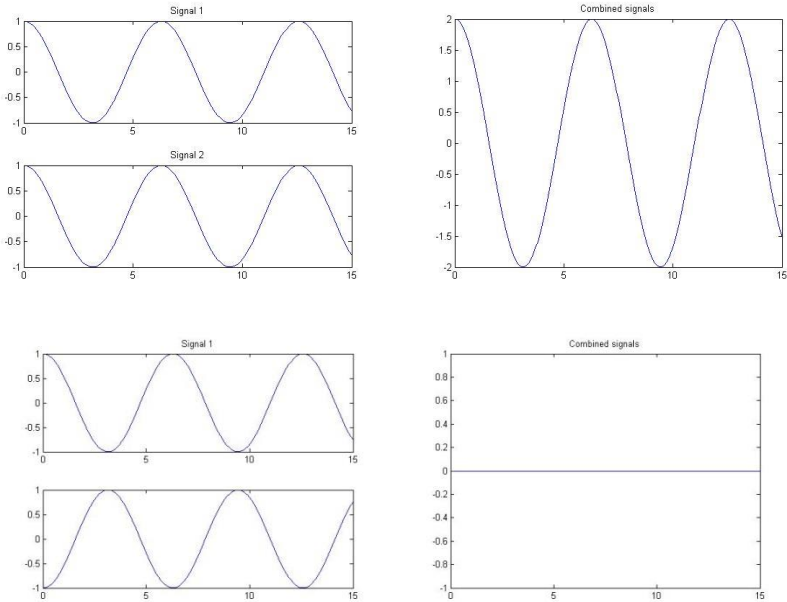

Figure 40: Results of signal reflection

In a building with many walls and object it is likely that multiple rays reach the receiver and the summation of all those rays will determine the final signal strength. As in Figure 41 shows is it normal that multiple rays will be received at the receiver which did all had a different propagation path.

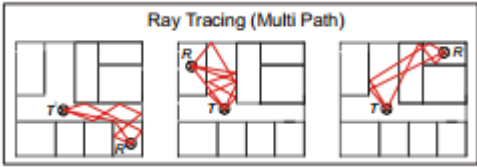

Figure 41: Reflections in environments [27]

This model of ray tracing needs factors to determine the amount of energy that is reflected, let through and absorbed by each wall. Based on those figures and the formula for signal attenuation the received signal strength can be estimated.

In order to estimate the signal strength rays are created at each transmitter, when the transmitter is unidirectional as with the TelosB node rays in all directions should be examined. In order to maintain acceptable running times an angle  $\alpha$  is used. This angle determines how many rays will be examined as illustrated in Figure 42.

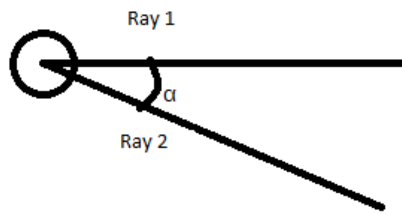

Figure 42: Ray creations

When setting  $\alpha$  to a very small angle many rays are created and estimations of all reflections can be calculated. However the smaller  $\alpha$ , the more computation power is required. Thus a trade-off should be made when setting alpha. In this case the model is used in a 2 dimensional fashion. In order to further increase its accuracy the 3th dimension could be included. However this will lead to far more complex system with way longer running times.

### 5.3 Analysis based on site survey data

To evaluate the different models and the possibility for adjustments the data from a site survey that was already carried out within the Nimbus Building by others. This site survey contains a big dataset where the signal strength is measured throughout the building. The prediction quality is measured by the mean absolute error and the mean squared error. The error is defined as the difference between the estimated and measured value. The absolute mean error indicates the average error per sample, and the mean squared error is an indicator which is used to give more weight to the outliers.

#### 5.3.1 The site survey

The site survey consists out of 3 scenarios, illustrated in Figure 43, Figure 44 and Figure 45. Scenario 1 and 2 have 5 nodes and scenario 3 got 4 nodes. All nodes are located on the same floor of the building. The site survey consists of the measurements between the nodes from a scenario and a sixth node which is used to measure the node to node RSSI.

The data gathering was performed with an extra node this node will be moved around the building in a constant phase. During the movement the signal strength values to the other nodes was measured and stored. Afterwards the location of the node was added to the measured signal strengths based on linear interpolation over time. When the path that the node took is known, and the speed at which it is moved around the location of the node in each moment in time is known. Based on this information the site survey is able to measure the RSSI over the entire building.



Figure 43: Scenario 1





Figure 44: Scenario 2

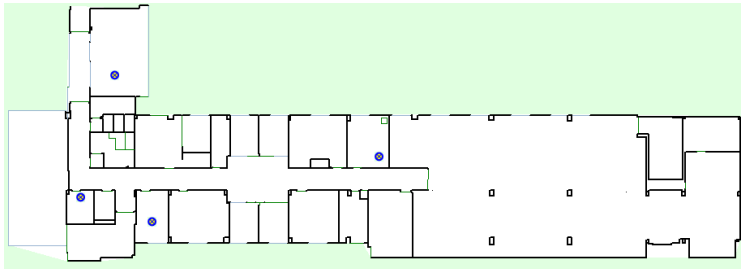

Figure 45: Scenario 3

On the floor plan of the building three different colours are used to draw the walls. Those different colours represent different types of walls. The black lines are heavy walls, the green lines are light walls and the grey lines are glass walls and windows. This results in a dataset of about 2000-2500 points per scenario.

In order to be able to benchmark the different techniques the three different scenarios of the site survey are used. For each technique one of the scenarios will be used as input and then tested against the complete set. In this way the learning set contains only one third of the test it is tested on and should give a good indication on whether the method can estimate the signal strength outside its own learning set. In the design tool only the ray tracing model is implemented. This implementation will act as a baseline to compare all the results to. The results are given by Table 4.

| Scenario               | Mean absolute error | Mean square error |
|------------------------|---------------------|-------------------|
| 1                      | 6.9                 | 74.8              |
| 2                      | 17.7                | 388.0             |
| 3                      | 9.7                 | 140.2             |
| All scenarios combined | 10.6                | 177.8             |

Table 4: Ray tracing model benchmark

On this site survey data set the average absolute error over the complete data set is 10.6 dBm. The free space loss for the used frequency is 40 dBm and the least amount of measurable signal is -95 dBm. Thus the prediction space is from -40 to -95 dBm, which is a range of 55 dBm. On a range of 55 dBm is an average error of 10 dBm is relative high. However these estimations can be made with only the floor plan of a building and no site surveys have to be conducted before the first analysis can be made.

### 5.3.2 Analysis of Model Predictions

That data of the site survey will be used to test how the multi wall model and the design output performs. And it will be seen if the models can be adjusted to see if the estimation quality can be improved with the site survey data as learning data.

#### 5.3.2.1 Analysis of the quality of the multi wall model

An implementation of the multi wall model was undertaken. In order to test the implementation only one of the three scenarios from the site survey set is used to learn the parameters of the model so that the model can then be tested on the complete dataset. For this method two different implementations are made, one where all walls are considered the of the same type and will thus have the same attenuation value, and one where each wall type (heavy walls, light walls and glass walls) will have its own attenuation value.

To determine the attenuation factors for the distance and walls linear regression is used. Linear regression is a mathematical technique which tries to fit a line through a set of points with the least mean square error. This technique can also be used in a multi-dimensional set of points, like for example multiple wall types. In that case multiple independent variables will get their own values.

Determining parameters of the model is done in two phases. In the first phase the parameter for the distance loss factor is learnt for each scenario. After this the costs of the wall or walls types are learnt. This is done because the distance loss attenuation is independent of the walls and should therefore be determined first. Than based on this factor can the wall attenuation factors be determined. When the distance and wall attenuation factors are determined together the distance loss attenuation factor can be influenced by the errors from the wall attenuation factor.

For learning the distance loss attenuation factor all measurements where the signal does not intersect a wall are used as the input. Based on this set the relation between the distance and the signal loss has to be determined. In Figure 46 the scatter plot of all points where no walls are in between the transmitter and receiver are scattered in blue. All those point where corrected with the free space loss attenuation, since the goal is to find out what the loss is caused by the distance and all other signal lost should be taken out of the measurements. Those points are the input for the linear regression. The red line is the output. The linear regression formula finds the line that has the best fit with a set of points.

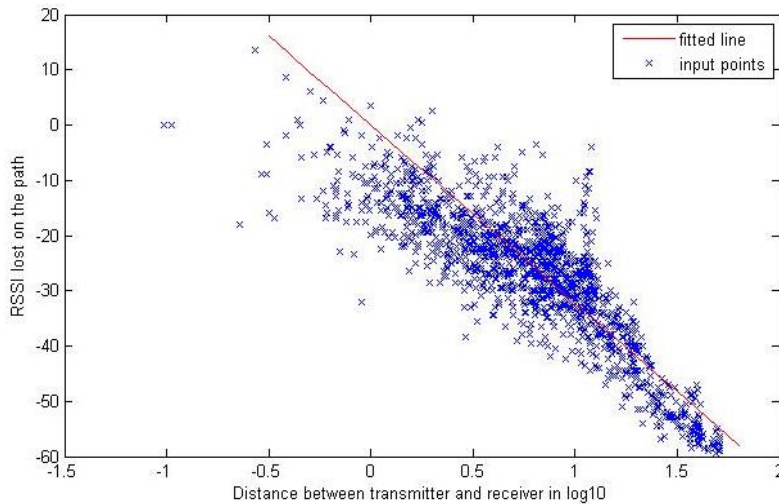

Figure 46: Site survey scenario 1 learning the distance loss parameter multi wall model

As Figure 46 shows not all the input points lay on the red line. Each measurement will have a deviation from the predicted signal. This deviation can come from either an inaccurate measurement method or the model does not capture all attenuation sources, like for example fading. When the deviation of the measurement method is evenly divided the use of more points will average out this the error. Thus more points will improve the design quality.

After learning the attenuation factor for the distance the same technique is applied for the walls the results are shown in Table 5.

| Learning scenario | Distance loss factor | 1 Wall type cost | 3 wall types: |         |         |
|-------------------|----------------------|------------------|---------------|---------|---------|
|                   |                      |                  | Heavy         | light   | glass   |
| 1                 | -31.5637             | -1.2417          | -1.2736       | -0.5828 | 0       |
| 2                 | -19.8664             | -3.3066          | -2.7828       | -4.5129 | -2.7597 |
| 3                 | -35.6873             | -1.3994          | -1.188        | -1.8183 | -2.838  |

Table 5: Multi wall model parameter learning

This table shows that the parameter the model learns heavily relies on the learning set. Even though all used learning sets come from the same type of communicating nodes and the same building the results are very different. For example the distance loss factor of scenario 3 is 79% bigger than in scenario 2. This makes learning the parameters for the model hard, since it is difficult to know whether the learning data is good or bad if there is no benchmarking. Therefore in general it can be said that the more points the learning data contains the smaller the errors of the learnt parameters.

To be able to compare the results benchmarking is applied. For the benchmarking of the learned parameters in the previous table are tested on the complete dataset from the site survey. The results of this benchmark are shown in Table 6

| Learning Scenario | Single wall Multi wall model |                   | Three wall types multi wall model |                   |
|-------------------|------------------------------|-------------------|-----------------------------------|-------------------|
|                   | Mean abs error               | Mean square error | Mean abs error                    | Mean square error |
| 1                 | 5.4                          | 49.2              | 5.5                               | 50.6              |
| 2                 | 9.8                          | 132.9             | 9.4                               | 123.8             |
| 3                 | 6.4                          | 65.7              | 6.4                               | 64.9              |

Table 6: Multi wall model benchmarking

When comparing the results of all scenarios it becomes clear this model is performing better than the ray tracing model for this specific configuration which had a mean absolute error on the complete dataset of 10.6 and a mean square error of 177.8. This is somewhat expected as it is tuned specifically to the environment where the prediction is carried out and it is not fair to directly compare both models rather to show that the multi wall model can be accurately tuned to reflect a very specific configuration but may not easily adapt to the general case.

**5.3.2.2 Adjusting the ray tracing model with site survey information.**

The ray tracing model initially estimates signal strengths between a transmitter and a receiver purely based on the floor plan of the building. The error from the model can be reduced by a number of possible options, 1. Improve the environment description, 2. Characterise the hardware better (radiation pattern, orientation etc) or 3. Optimise the parameters of the walls for the specific types based on site survey data. For the context of this research access to the model implementation is not available. As a result it was investigated if a simple offset could be generated based on the data collected within the network to create a closer fit between the prediction and measurement.

Just like with the parameter learning of the Multi Wall Model linear regression is used to find the adjustment values for the propagation distance and the different wall types. The difference between this approach and the multi wall model is that here adjustments are made on top of an already existing modes. The differences between the estimation’s and the measured values are used as input.

The learned parameters for the ray tracing model are shown in Table 7.

| Learning scenario | Distance loss factor | Single wall type | Multiple walls types |            |            |
|-------------------|----------------------|------------------|----------------------|------------|------------|
|                   |                      |                  | Heavy wall           | Light wall | Glass wall |
| 1                 | -2.5                 | 2.1              | 2.3                  | 2.5        | -1.8       |
| 2                 | 2.7                  | 2.8              | 2.9                  | 2.1        | 3.4        |
| 3                 | -7.8                 | 4.2              | 4.3                  | 3.3        | 6.6        |

Table 7: Correction coefficients for the Ray tracing model

Even though these parameters adjust the same model and the learning scenarios come from the same building the outcome of the parameters are completely different. The used datasets did all contain more than 2000 samples to learn the parameters but still the differences are high.

To see what the effects of the learnt coefficients are will the results be tested on the complete dataset. The results of the adapted ray tracing model are given in Table 8.

| Learning scenario | Single wall type    |                   | Multiple wall types |                   |
|-------------------|---------------------|-------------------|---------------------|-------------------|
|                   | Mean absolute error | Mean square error | Mean absolute error | Mean square error |
| 1                 | 8.0                 | 104.2             | 8.0                 | 103.5             |
| 2                 | 8.0                 | 98.1              | 7.9                 | 96.2              |
| 3                 | 8.4                 | 111.5             | 8.4                 | 111.5             |

Table 8: Error values of the adapted ray tracing model

The error rates of all three scenarios are significantly lower than without the wall correction, therefore can be concluded that correcting the ray tracing model based on measurements in the

building will increase the estimation quality of the signal strength even though the outcomes can be very different.

In Figure 47: Scenario 3 model adjustment using a single wall the result of the adjusted model is plot together with the original estimation and the measured value. The figure was created using scenario 3 to lean the parameters and one wall was considered. This figure shows that the adjusted ray tracing model is able to more accurately estimate the signal strength than the original model.

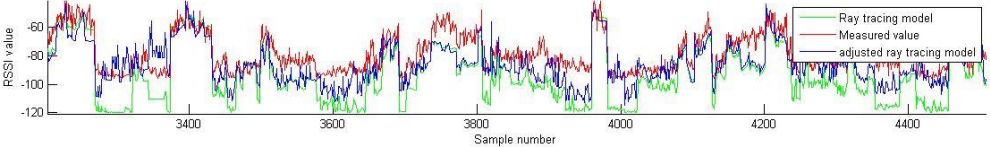

Figure 47: Scenario 3 model adjustment using a single wall

In Figure 48 the difference in the estimated value between the ray tracing model and the adjusted ray tracing model is plotted. This shows that for most of the samples the adjusted ray tracing model had a better prediction than the original ray tracing model. There are multiple samples where estimations of th adjusted model are worse. Due to those samples with decreased quality can be concluded that this method is not monotonically decreasing. This makes the use of it harder since it can't be proven that the adjustments to the model will lead to better results in each specific case. The average over a large dataset will give a better result which indicates that the adjustments are improving the model.

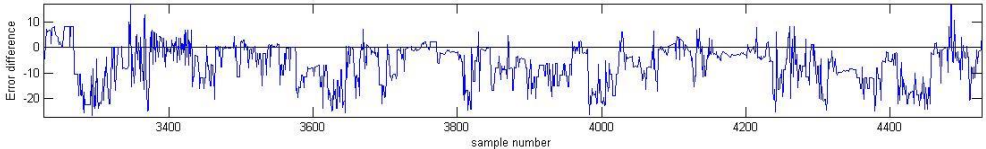

Figure 48: Difference in estimation error between adjusted model and original model

Now that the ray tracing model and the multi wall model both had learned their parameters from a site survey data set both models can be compared. This comparison shows that the multi wall model is still performing better than the Ray tracing model, thus when a site survey is constructed it is better to use the multi wall model than the adjusted ray tracing model.

### 5.4 Ray tracing model adjustment based on the data from real deployments

When a deployment is deployed which does not fulfil its requirements redeployment has to be considered. However the initial design created using the design tool did not estimate the reality sufficient enough to come to good quality design. Therefore the estimation should be improved based on the information given by the real deployment. Thus the design tool should be able to learn based on the information from the deployment.

From the analysis of the site survey it is possible that using real data can improve both the multi wall model and the ray tracing model. However these analyses require relative large data sets where available. Each site survey scenario contained over 2000 samples. These big datasets are normally

not available and only the information which is can be extraction from a real deployment can be used.

When a deployment is used of for example 10 to 20 nodes normally no more than 30 samples are known. This data set is too small to successfully learn the parameters of the multi wall model. Therefore only corrections for the ray tracing model are considered.

When learning from site survey data sets two different leaning methods where used. One was to consider all walls of the same type, and the other one to create different parameters for the different types of walls. The differences between the results of two different methods were small. In some cases the method where only 1 wall was used performed even better than the method where three different wall types where considered and the other way around. Overall the two methods performed more of less the same. Therefore only wall type is considered in this section. The more parameters need to be learned the bigger the dataset should be, since the used dataset is very small the number of learning parameters should be kept to a minimum.

### 5.4.1 Ray tracing model update using a single wall type

The input for the updating the model is the data which comes from a real deployment. The used deployment and the by the deployment tool estimated RSSI values is illustrated in Figure 49. The deployment contains 10 nodes and a sink. The deployment used during operation 11 different links. That means that the dataset available for the model adjustments also contain 11 point.

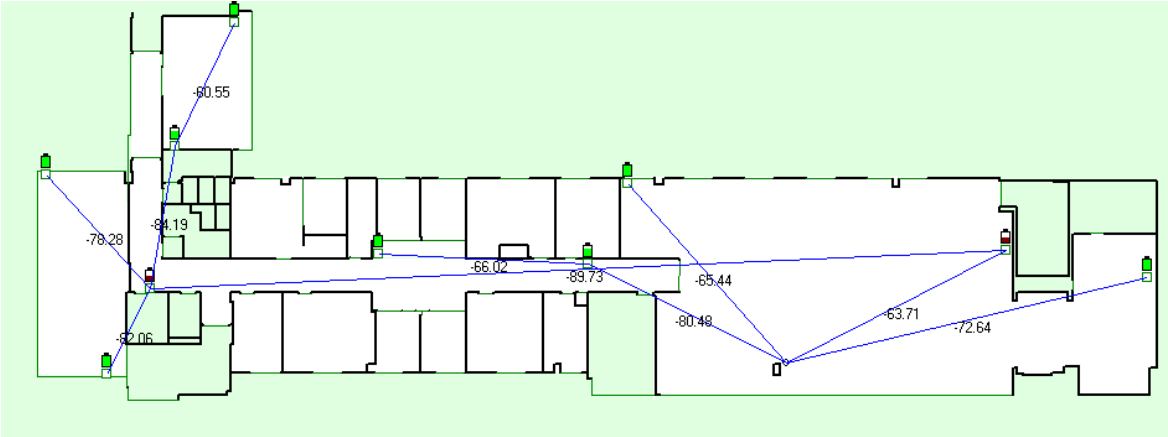

Figure 49: Deployment used for updating ray tracing model

First the distance attenuation factor is adjusted. Since the deployment contained only 4 links which did not propagate through walls the data set for this is really small. Figure 50 shows the 4 points and the fitted line. This set resulted in a distance adjustment factor of -2.9.

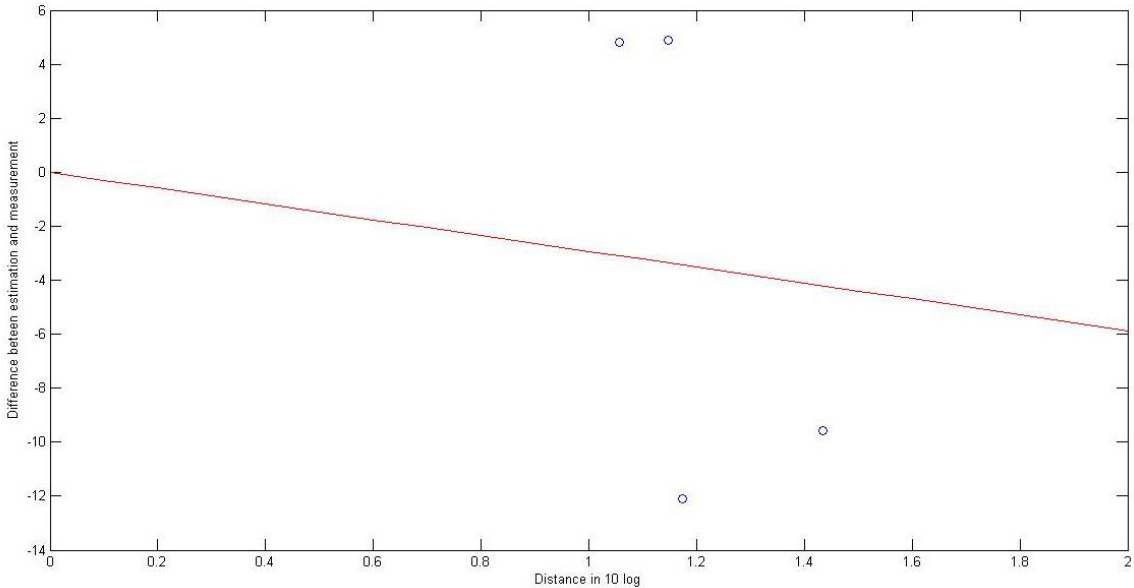

Figure 50: Distance versus prediction error

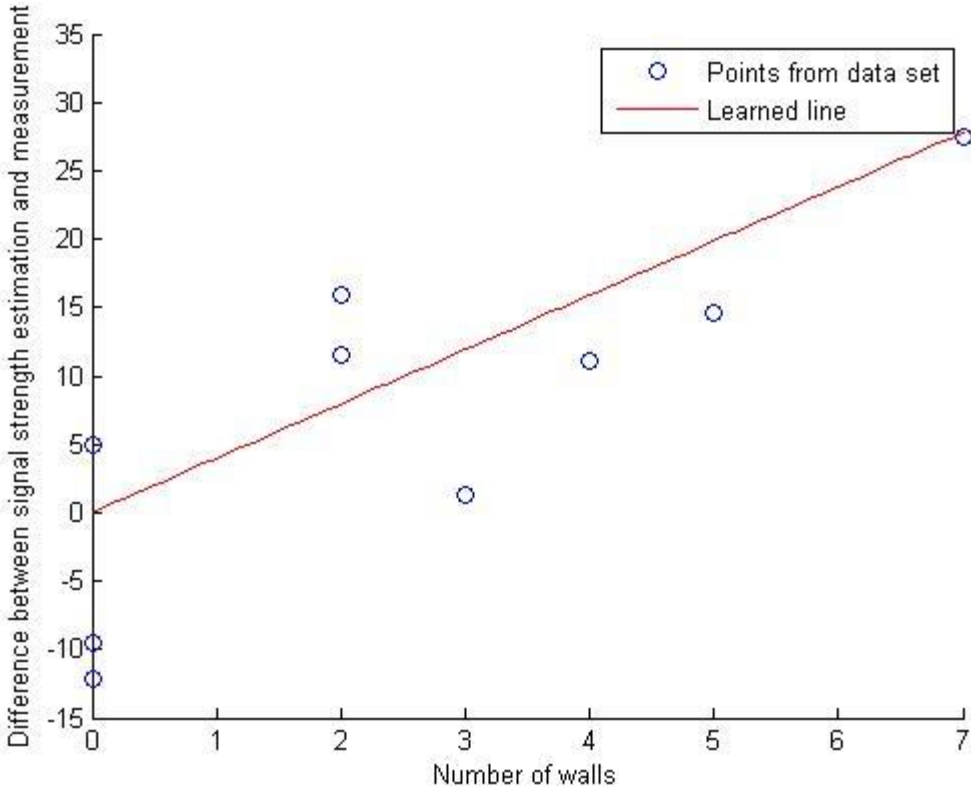

Figure 51: Parameter learning based on real deployment data

As Figure 51 shows does this learning set have a relationship between the number of walls the signal propagates through and error in the model. The red line shows the relationship which is learned

based on this input dataset. A same relation exists for the distance however, due to the limited input where only 4 samples known to learn the distance adjustment factor.

This relationship is that for each wall a correction of 3.9 should be applied to the estimation.

Testing this on the dataset which is obtained by the site survey shows that the mean average is now 8.3 instead of 10.6 and the mean square error 114.1 instead of 177.8. This is a significant decrease of the mean absolute error by about 20% and the for the mean square error the decrease is even stronger. This shows that on average the prediction quality is increased and that there is a decrease of outliers.

From this can be concluded that using a small learning set can already give a significant improvement of the quality of the ray tracing model, and is therefore advised to use when redeployments are considered.

#### 5.4.2 Ray tracing model update where each wall is wall has its own correction value

Next to the optimisation where all walls are considered to have the same error rate another option to update the model exists. Since the difference between each prediction and measurement is known local optimisation is also possible. In this case all walls considered too be independent objects, thus the correction factors are no longer related. Instead the prediction error will be evenly divided by all walls which are in-between the transmitter and receiver. This way the prediction is adjusted in such a way that for that specific case all predictions match. However in the prediction not all the errors come only from the walls. Also errors are introduced by the distance signal loss estimation. This error is in the first case added to the walls.

When redeployment is considered nodes will be relocated or new nodes are added to the network. The correction values for the walls contain the combined errors of the walls and the distance signal loss error. Thus the estimated values for the relocated or added nodes are likely to be incorrect. However since the error of the distance is assumed to be smaller than the error for the walls the remaining error is assumed to be smaller than the initial error. When multiple values for a single wall exists the error for the distance loss is likely to be filtered out and in this way only the error for each specific wall will remain.

Applying this method to the deployment used for this section and tested on the site survey data gives a mean absolute error of 10.3 and a mean squared error of 167. These results are slightly better than the original 10.6 and 177.8 but the change is only small. Therefore I suggest that this is not the model to use.

## 5.5 Conclusion

The goal of this section was to find out how to improve the quality of a deployment. To do so the model used for predictions of the signal strengths are analysed. For those analysis a benchmark was setup. This benchmark is used to see what the quality of the model is and how any changes to model improve or degrade the quality of the estimations.



For improving the design two different approaches were used. One is to use a relative large data set obtained by a site survey to adapt the model. The other approach is to only use the data from an deployment.

When a site survey set is present two different models can be used to estimate signal strengths through the building. A simple Multi Wall Model, or the more advanced ray tracing model. The multi wall model estimates the signal strength based on the distance between a transmitter and receiver and the number and types of walls on the propagation path. The ray tracing model includes next to the distance and wall types also reflections. When a signal hits a wall a part of the signal is reflected. This reflection can have a great impact on the signal strength.

From the dataset adjustment parameters for the walls should be extracted. The ray tracing model already estimates the cost of propagating a signal through a wall, the goal of learning is to improve the estimated cost of the walls. This can be done by estimating the cost per wall type. A heavy wall is likely to absorb more signal than a light wall and should thus get another cost value. However comparing the cost per wall approach with having a single wall type and thus a single cost the results are almost the same. Therefore I would suggest to use single wall types when doing these model adjustments.

From the analysis of the site survey learning approach did the multi wall model show the best results with an average mean absolute error of 7.2dBm where the original model had a mean absolute error of 10.6dBm. The improved ray tracing model gave an average mean absolute error of 7.7 dBm. The results of the ray tracing model and the multi wall model are almost the same however, the multi wall model got a lot deviation in its results, in 3 samples it had as the best result of 5,4 dBm and the worst of 9,8 dBm. The ray tracing model seems more stable where the best result was 7,3 dBm and the worst 8,3 dBm. Therefore I would recommend to use the ray tracing model when improving a model based on a site survey dataset.

Next to the site survey dataset also the possibilities of improving the signal strength estimation based on the data from an active deployment is analysed. The major difference between the learning from an active deployment and from a site survey is size of the dataset. An indoor deployment typically exists out of 10 to 50 nodes. From a deployment of this size can 50 to 150 links be used as input for adapting the model. With the site survey 2000 points were used to learn the model.

Due to the small dataset which can be used when the data is extracted from active deployments can only the ray tracing model be used. Since this model does not have to learn all its parameters from the dataset but only creates adjustments to the model. From earlier analysis we already saw that assuming that all walls are of the same type will give just as good results as using multiple wall types.

Adjusting the ray tracing model based on an small deployment of 11 nodes and tested the results on the site survey data gave as result that the mean absolute error went from 10.6 dBm to 8.2. This is an 22% improvement. Therefore can be concluded that even though the datasets which can be extracted from small deployment the original model can be adjusted to significantly improve the design quality.

Next to adjusting the ray tracing model using a single wall type it is also possible to give each wall a correction value. This way local optimizations can be made. When an estimation contains an error,

this error can be adjusted by changing to cost value of the walls on the propagation path. This method leads to local optimizations. However the estimation error is not only induced by the walls on the propagation path. So when adjusting only the walls cost value all other errors will be included in this value. When moving node, the other errors like distance loss will change while it is still encapsulated in the cost value for the wall. When repeating this multiple times, the other errors will filter out and a cost value per wall remains. This method is not very useful when using it on the data set from a real deployment since this method will required multiple measurements per wall, and this data set will often only contain a single value per wall.

Overall can be concluded that adapting the ray tracing model and learning the multi wall model based on the data from a site survey both will give a significant improvement over the results of the original ray tracing model. However for this method a site survey is required. When no site survey is performed and only the data form a deployment is known the data set to lean the adjustment parameters from is small. Therefor only the ray tracing method will be adjusted. The quality of the model using the only the small dataset is also improved, but not as much as when the site survey is conducted. Therefor is suggest that only the single wall method is used when adjusting the ray tracing model based on the data from a deployment.

## 6 Conclusion

This thesis focused on the following objectives:

1. What data can be extracted from a live network and how can it be used to analyse and verify the performance of the WSN post-deployment?
2. How can the network be configured/re-configured in the case of poor performance to ensure requirements are met while maintaining a maximum lifetime?
3. How can the extracted information be feed back to the design phase to improve on the site specific deployment?

After the planning and deployment of a wireless sensor network is done the question arises. *“How well does the network perform, and is the current configuration the optimal configuration of the network?”* In order to be able to answer those questions the first objective is used. What data can be extracted from a live network and how can it be used to analyse and verify the performance of the WSN post-deployment?

Analysing a wireless network is done at three different abstraction layers. The physical layer, which checks the quality of the signal used for communication, the link layer which checks the probability a packet is transmitted successfully between two nodes and the transport layer which checks the connectivity of a node with the sink. Each layer has its own related metrics and its own way of analysing the network. This is discussed extensively in section 4.1. What this section shows is that for all 3 layers metrics exist in the network which reflect the quality of the layer. For the physical level the RSSI values show that as long as the RSSI is over -87 dBm that the physical link will be of a good quality. As soon as the RSSI value drops below the -87 dBm the link quality will degrade rapidly. For the link-layer quality the ETX metric is used. This number is the inverse of the probability that a communication over both the up and down links succeeds. This number can be used to estimate the probability that a packet is successfully transmitted over the down link. The last metric used for the analysis is the packet reception ratio. This number reflects the ratio between number of packets that reached the sink and that where created by each node. Multiple methods are available to estimate the end-to-end packet reception rate. Testing those methods showed that using EWMA was the method that showed the strongest relation.

Once analysis can be made the configuration of the network is the next concern. Is the network configured in such a way that it utilises its resources as good as possible. Or *“How can the network be configured/re-configured to ensure requirements are met while maintaining a maximum lifetime?”* In this thesis a configuration framework was created. The configuration framework strives to create a configuration that meets the by the application required quality of service while maintaining a maximum lifetime of the network. The lifetime is optimized by minimizing the load on the entire network. To do so 3 configuration options are used. The transmission power of the nodes, the maximum number of retransmissions and the number of duplications of the packets.

The transmission power is configured independently of the number of retransmissions and number of duplications. As the analysis of the RSSI showed, the link maintain a high quality when the RSSI values are higher than -85. When the worst incoming or outgoing link from a node is 7 or 15 dBm higher, -85, the transmission power of that node can be lowered without compromising on the quality of the communication.

The number of duplications and number of retransmissions are configured based on the ETX values of the links. The ETX reflects the communication quality of a link and is therefore used to estimate the reliability of the nodes. Retransmissions on a link level or duplicating packets on a node level will both impact the reliability of a node at the same way. However when retransmissions are used all packets that are forwarded by that node will be retransmitted which might lead to an unnecessary induced extra load on that node. When not all nodes require the same reliability the nodes that have a higher reliability might compensate the bad network quality by sending multiple instances of the same packet, so that no retransmissions on a link level are required. To determine what the best configuration are, two formulas are used to calculate the total load on the network. By finding the configuration that delivers all nodes their required QoS and minimizing the load on the network the optimal configuration can be found.

This method will create a configuration for the network based on the information from a specific point in time. To do so the topology and the link qualities are used as input. However one the property of wireless sensor networks is that they are highly dynamic. Thus the used topology and the link quality could vary over time, making the derived configuration invalid. In order to maintain a good network the configuration should be updated continuously.

To verify the configuration framework the Nimbus test bed was used. This test bed was tested under one specific configuration. Using other configurations caused the network to be unstable or to be unable to form a network at all. Due to these problems, I was unable to verify the configuration framework. Therefore no statements about the quality of the configuration framework can be made.

The other part of thesis focused on how information from deployments can be used to improve the deployment planning. This involved the question: *“How can the extracted information be feed back to the design phase to improve on the site specific deployment?”* To answer the question two estimations models were used. The already implemented ray tracing model and the multi wall model. The results of those two models are compared to each other. For improving the quality of the models two different inputs were used. One from a site survey, which contains a relative large data set, and one is from a deployment which contains a small dataset. To measure the quality of a model the by the deployment tool used ray tracing model and the site survey data set was used. This data set contained over 7000 points. The mean absolute error and the mean square error over the site survey data set were taken as a benchmark. The mean absolute error was 10.6 dBm and the mean square error 177.8.

First the site survey; the complete site survey consists of 3 scenarios. Each scenario alone was taken as input to improve the model. The result was then tested against the complete site survey dataset. The results show that even though the datasets are all relatively large and gathered in the same building with the same nodes the differences outcome of the different scenarios are large. Even though the outcomes might differ all outcomes were better in estimating the attenuation than the original ray tracing model.

Comparing the results of the two different models shows that the Multi wall model is on average better able to estimate the signal strengths than the ray tracing model. However the ray tracing model is more constant and therefore I would recommend to use the ray tracing model.

The second scenario was improving the estimation quality based on the data from real deployments. A test deployment was used that contained 11 links. Thus the input set was 11 points large. Due to the limited size of the input set is only the ray tracing model was taken into account. Learning the adjustment parameters and comparing to the benchmark shows that even though the input set was small the adjustments to the model did significantly improve the estimation quality. The mean absolute error was reduced by 22% and the mean square error by 36%. This means that not only the average prediction quality is much better but also that the adjusted model contains significantly less outliers. This means that the probability of an estimation of specific points is more likely to reflect the actual value than before.

This theses suggested a method for configuring the network. However this method was not extensively tested. Therefore the next step should be to update the test bed, and use the suggested configurations to see how it works. Another issue which needs to be solved in the future is how to cope with the dynamics of the network in relation to the configuration. How long is a configuration valid, and thus how often should the network be reconfigured?

Once the configuration methodology is tested and it turns out to be working fine, a next step would be so research how this can be done in a distributed way. Now everything is done in a centralized fashion which is possible for small networks, but when the network size increases to hundreds of nodes this would not be feasible and distributed QoS support should be the next step to tackle this problem.

## 7 Bibliography

- [1] D. Hui and R. Han, "A node-centric load balancing algorithm for wireless sensor networks," *Global Telecommunications Conference*, pp. 548-552, 2003.
- [2] M. Nabi, M. Geilen and T. Basten, "An Empirical Study of Link Quality Estimation Techniques for Disconnection Detection in WBANs".
- [3] S. Dawson-Haggerty, A. Tavakoli and D. Culler, "Hydro: A Hybrid Routing Protocol for Low-Power and Lossy Networks," *Smart Grid Communications (SmartGridComm)*, vol. Oct, pp. 268-273, 2010.
- [4] S. Poduri, S. Pattem, B. Krishnamachari and G. Sukhatme, "Sensor network configuration and the curse of dimensionality," *IEEE Workshop on Embedded Networked Sensors*, May 2006..
- [5] X. Cheng, D.-Z. Du, L. Wank, B. Xu and D, "Relay sensor placement in wireless sensor networks," *ACM/Springer Journal of Wireless Networks*, vol. 14, p. 347 355, 2008.
- [6] W. Wei, C. Wan-Dong, W. Bei-Zhan, W. Ya-Ping and T. Guang-Li, "The Factor Graph Approach for Inferring Link Loss in MANET," *International ocnference on Internet computing in science and engineering*, 2008.
- [7] K. Srinivasan and P. Levis, "RSSI is Under Appreciated," *In Proceedings of the Third Workshop on Embedded Networked Sensors*, 2006.
- [8] V. Erceg, L. J. Greenstein and S. Y. Tjandra, "An Empirically Based Path Loss Model for Wireless Channels in Suburban Environments," *IEEE JOURNAL ON SELECTED AREAS IN COMMUNICATIONS*, vol. 17, pp. 1205-1211, 1999.
- [9] A. Mainwaring, D. Culler, J. Polastre, R. Szewczyk and J. Anderson, "Wireless sensor networks for habitat monitoring," *ACM international workshop on Wireless sensor networks and applications*, pp. 88-97, 2002.
- [10] D. Hughes, P. Greenwood, G. Blair, G. Coulson and P. Grace, "An experiment with reflective middleware to support grid-based flood monitoring," *Concurrency and Computation: Practice & Experience* , pp. 1303-1316, 2006.
- [11] G. Coulson, R. Gold, M. Lad, C. Mascolo and L. Mottola, "Dynamic Reconfiguration in the RUNES Middleware," *Mobile Adhoc and Sensor Systems (MASS)*, pp. 574-577, 2006.
- [12] N. Vlajic and D. Stevanovic, "Performance Analysis of ZigBee-Based Wireless Sensor Networks with Path-Constrained Mobile Sink(s)," *Sensor Technologies and Applications*, pp. 61-68, 2009.
- [13] P. Radmand, A. Talevski, S. Petersen and S. Carlsen, "Comparison of industrial WSN standards,"

*Digital Ecosystems and Technologies (DEST)*, pp. 632-637, 2010 .

- [14] C.-K. Brendan , G. David , E. Desmond and S. C. Ricardo , “Performance evaluation of the 6LoWPAN protocol on MICAz and TelosB motes,” *Performance monitoring and measurement of heterogeneous wireless and wired networks*, pp. 25-30, 2009.
- [15] . A.-E.-B. Mostafa, A. M. Y. Mohamed and M. A.-O. Mariam , “WIRELESS SENSOR NETWORKS – PART I: TOPOLOGY AND DESIGN ISSUES,” *Electrical and Computer Engineering*, pp. 1165-1168, 2005.
- [16] E. Stavrou and A. Pitsillides, “A survey on secure multipath routing protocols in WSNs,” *Computer Networks*, vol. 54, no. 13, pp. 2215-2238, 2010.
- [17] S. K. Singh, M. P. Singh and D. K. Singh, “Routing Protocols in Wireless Sensor Networks – A Survey,” *International Journal of Computer Science & Engineering Survey (IJCES)*, vol. 1, no. 2, pp. 63-83, 2010.
- [18] Crossbow, “Crossbow TelosB Datasheet,” Crossbow.
- [19] Chipcon, Datasheet of the CC2420 radio chip used in the telosB nodes.
- [20] N. Javaid, A. Javaid, I. Khan and K. Djouani, “Performance study of ETX based wireless routing metrics,” *Computer, Control and Communication*, pp. 1-7, 2009.
- [21] Y. Wei , J. Heidemann and D. Estrin, “Medium Access Control With Coordinated Adaptive Sleeping for Wireless Sensor Networks,” *Networking, IEEE/ACM Transactions on*, vol. 12, no. 3, pp. 493-506, 2004.
- [22] C. Chee-Yee and S. Kumar, “Sensor networks: evolution, opportunities, and challenges,” *Proceedings of the IEEE*, no. 91, pp. 1247-1256, 2003.
- [23] L. Ruiz, J. Nogueira and A. Loureiro, “MANNA: a management architecture for wireless sensor networks,” *Communications Magazine, IEEE* , no. Feb 2003, pp. 116-125, 2003.
- [24] D. Chen and P. K. Varshney, “QoS Support in Wireless Sensor Networks: A Survey,” *Conference on Wireless Networks*.
- [25] S. Hadim and N. Mohamed, “Middleware: middleware challenges and approaches for wireless sensor networks,” *Distributed Systems Online*, pp. 1-23, 2006.
- [26] M. Perillo and W. Heinzelman , “Providing Application QoS through Intelligent Sensor Management,” *Sensor Network Protocols and Applications*, pp. 93-101, 2003.
- [27] L. Chenyang , B. Blum, T. Abdelzaher, J. Abdelzaher and H. Tian , “RAP: a real-time communication architecture for large-scale wireless sensor networks,” *Real-Time and Embedded Technology and Applications Symposium*, pp. 55-66, 2002.

- [28] T. Rappaport and S. Sandhu, "Radio-wave propagation for emerging wireless personal-communication systems," *Antennas and Propagation Magazine*, pp. 14-24, 1994.
- [29] M. Lott and I. Forkel, "A multi-wall-and-floor model for indoor radio propagation," *Vehicular Technology Conference*, pp. 464 - 468, 2001.
- [30] J. Zhong , L. Bin-Hong, W. Hao-Xing, C. Hsing-Yi and T. Sarkar, ""Efficient ray-tracing methods for propagation prediction for indoor wireless communications," *Antennas and Propagation Magazine*, pp. 41 - 49, 2001.
- [31] G. Wahl, P. Wölfle and P. Wertz, "Dominant Path Prediction Model for Urban Scenarios," *Mobile and Wireless Communications Summit*, p. ?, 2005.
- [32] S. Seidel and T. Rappaport, "914 MHz path loss prediction models for indoor wireless communications in multifloored buildings," *Antennas and Propagation*, pp. 207-217, 1992.
- [33] A. Guinard, "A Design Tool for WSN Design in Buildings," *Mater Thesis at Nimbus*. 2011