

## Apparatus for characterizing a vessel wall

**Citation for published version (APA):**

Ruijters, D. S. A. (2022). Apparatus for characterizing a vessel wall. (Patent No. *US2022095935*).  
[https://nl.espacenet.com/publicationDetails/biblio?II=0&ND=3&adjacent=true&locale=nl\\_NL&FT=D&date=20220331&CC=US&NR=2022095935A1&KC=A1](https://nl.espacenet.com/publicationDetails/biblio?II=0&ND=3&adjacent=true&locale=nl_NL&FT=D&date=20220331&CC=US&NR=2022095935A1&KC=A1)

**Document status and date:**

Published: 31/03/2022

**Document Version:**

Publisher's PDF, also known as Version of Record (includes final page, issue and volume numbers)

**Please check the document version of this publication:**

- A submitted manuscript is the version of the article upon submission and before peer-review. There can be important differences between the submitted version and the official published version of record. People interested in the research are advised to contact the author for the final version of the publication, or visit the DOI to the publisher's website.
- The final author version and the galley proof are versions of the publication after peer review.
- The final published version features the final layout of the paper including the volume, issue and page numbers.

[Link to publication](#)

**General rights**

Copyright and moral rights for the publications made accessible in the public portal are retained by the authors and/or other copyright owners and it is a condition of accessing publications that users recognise and abide by the legal requirements associated with these rights.

- Users may download and print one copy of any publication from the public portal for the purpose of private study or research.
- You may not further distribute the material or use it for any profit-making activity or commercial gain
- You may freely distribute the URL identifying the publication in the public portal.

If the publication is distributed under the terms of Article 25fa of the Dutch Copyright Act, indicated by the "Taverne" license above, please follow below link for the End User Agreement:

[www.tue.nl/taverne](http://www.tue.nl/taverne)

**Take down policy**

If you believe that this document breaches copyright please contact us at:

[openaccess@tue.nl](mailto:openaccess@tue.nl)

providing details and we will investigate your claim.



(19) **United States**

(12) **Patent Application Publication**  
**RUIJTERS**

(10) **Pub. No.: US 2022/0095935 A1**

(43) **Pub. Date: Mar. 31, 2022**

(54) **APPARATUS FOR CHARACTERIZING A VESSEL WALL**

*A61B 5/0215* (2006.01)

*A61B 5/026* (2006.01)

*A61B 5/055* (2006.01)

(71) Applicant: **KONINKLIJKE PHILIPS N.V.**,  
Eindhoven (NL)

*A61B 8/08* (2006.01)

*A61B 8/00* (2006.01)

(72) Inventor: **Daniel Simon Anna RUIJTERS**,  
EINDHOVEN (NL)

*A61B 6/03* (2006.01)

*A61B 8/04* (2006.01)

*A61B 8/12* (2006.01)

(21) Appl. No.: **17/548,505**

(52) **U.S. Cl.**

(22) Filed: **Dec. 11, 2021**

CPC ..... *A61B 5/02007* (2013.01); *G01R 33/5635* (2013.01); *A61B 6/504* (2013.01); *A61B 8/06* (2013.01); *A61B 5/02014* (2013.01); *A61B 5/0215* (2013.01); *A61B 5/026* (2013.01); *A61B 5/055* (2013.01); *A61B 8/0891* (2013.01); *A61B 8/4416* (2013.01); *A61B 6/032* (2013.01); *A61B 6/4417* (2013.01); *A61B 8/04* (2013.01); *A61B 8/12* (2013.01); *A61B 6/03* (2013.01); *A61B 5/743* (2013.01)

**Related U.S. Application Data**

(63) Continuation of application No. 15/767,778, filed on Apr. 12, 2018, now Pat. No. 11,202,575, filed as application No. PCT/EP2016/074118 on Oct. 10, 2016.

(30) **Foreign Application Priority Data**

Oct. 14, 2015 (EP) ..... 15189794.9

(57) **ABSTRACT**

**Publication Classification**

(51) **Int. Cl.**

*A61B 5/02* (2006.01)

*A61B 5/00* (2006.01)

*A61B 6/00* (2006.01)

*A61B 8/06* (2006.01)

The invention presents an apparatus (6) for characterization of a condition of a vessel (12) wall of a living being (2). The relationship between temporal blood pressure (621) and blood flow (622) measurements of pulsatile blood motion within the vessel (12) is an indication of the health of the vessel (12) wall. Furthermore, the invention discloses a system (1) comprising the apparatus (6), and a method (100) of characterizing the condition of vessel (12) walls.

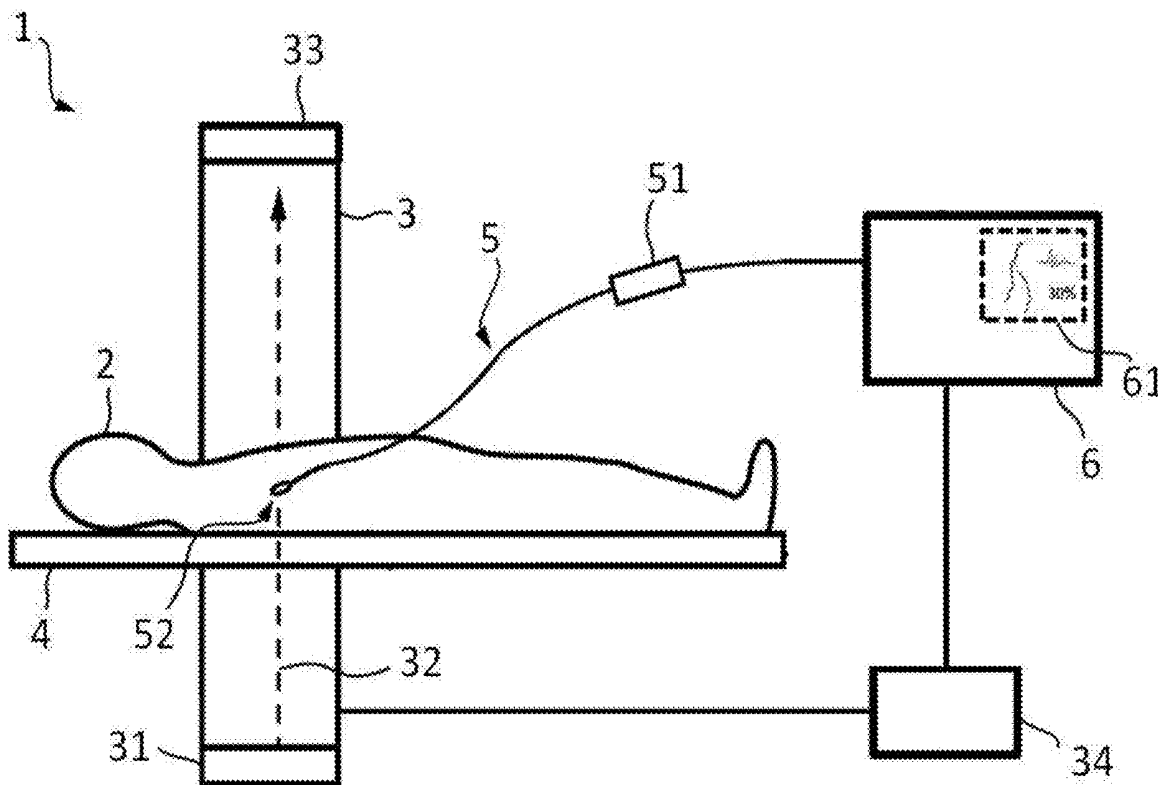

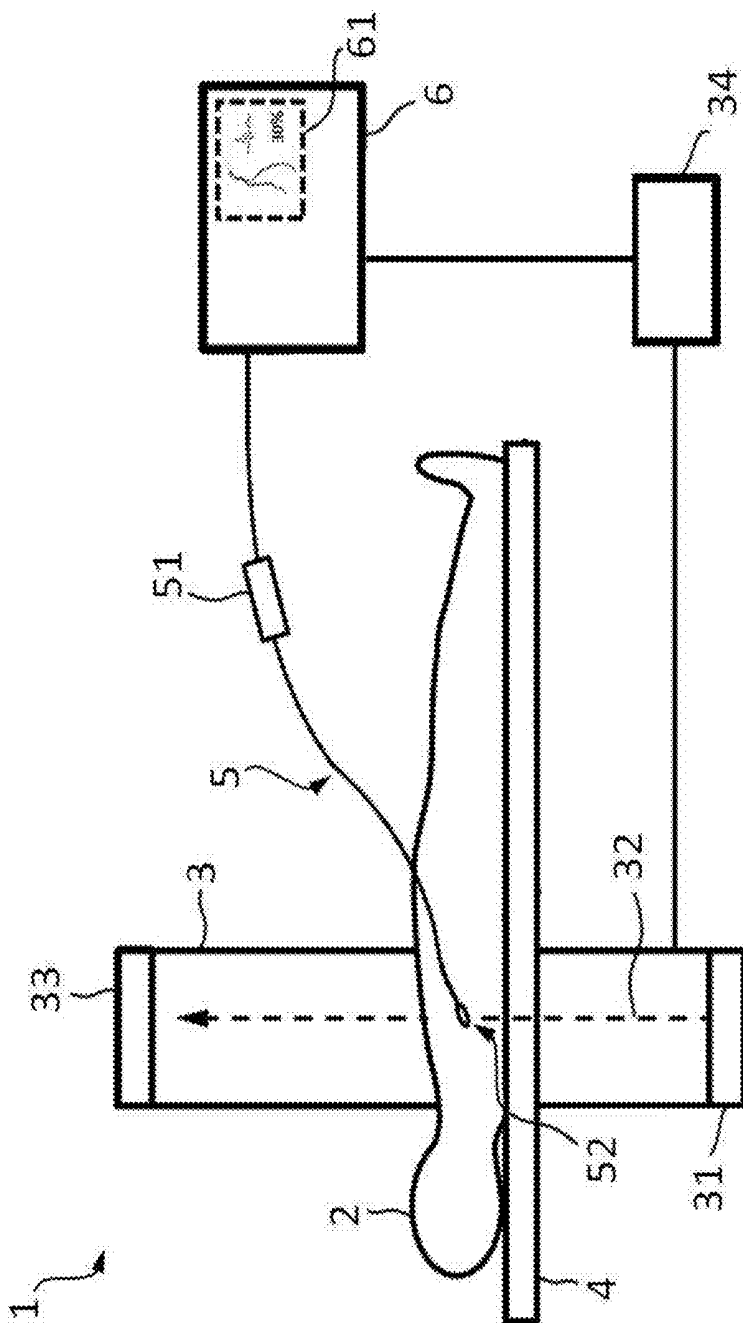

Fig. 1

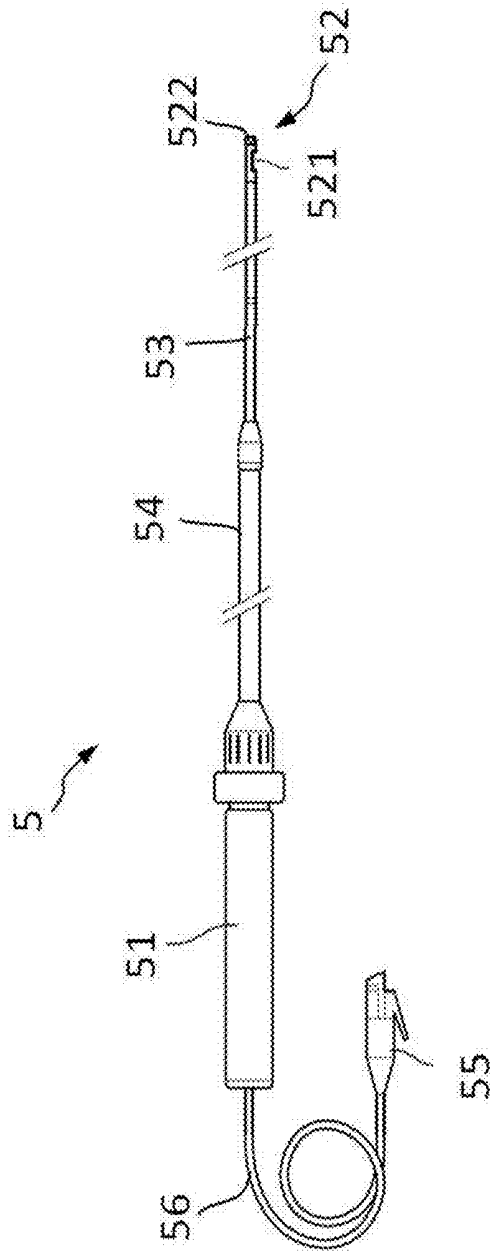

Fig. 2

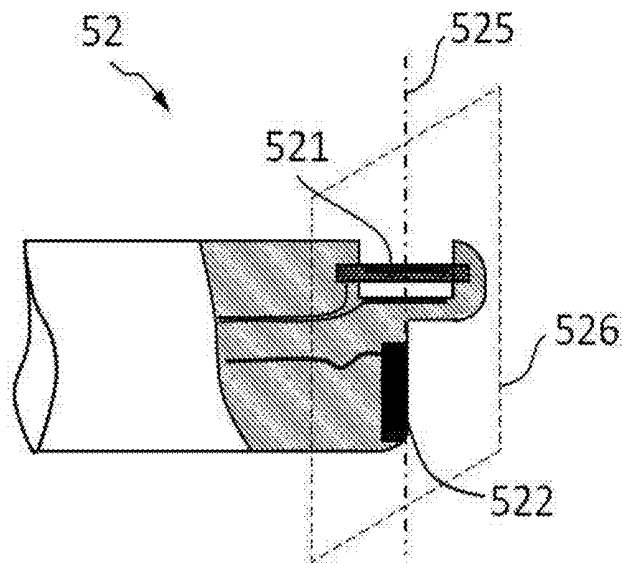

Fig. 3

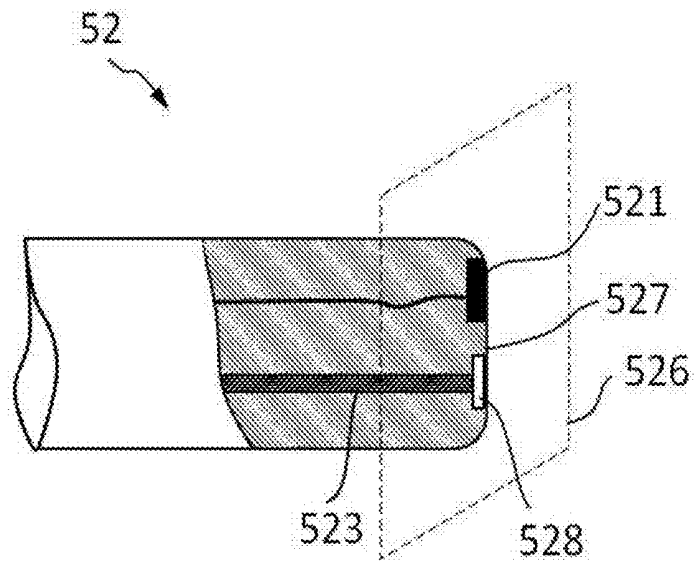

Fig. 4

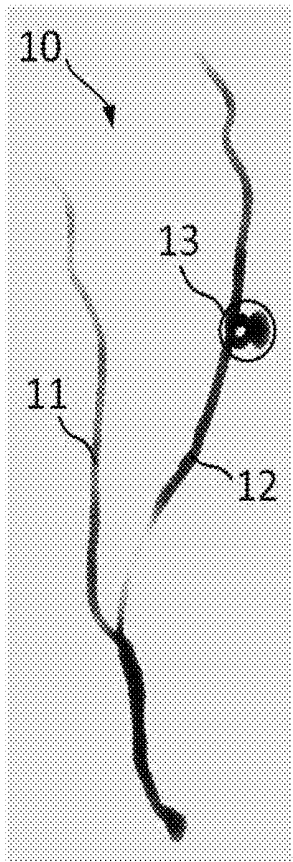

Fig. 5

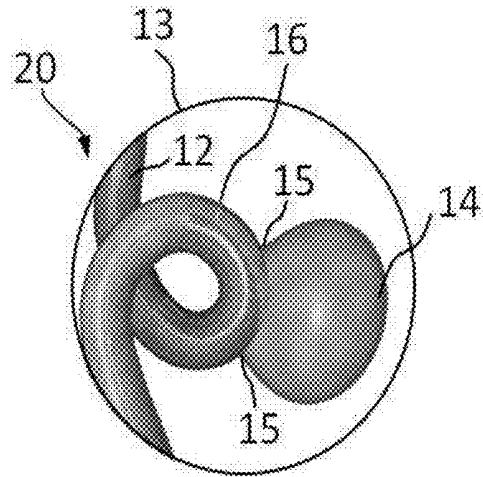

Fig. 6

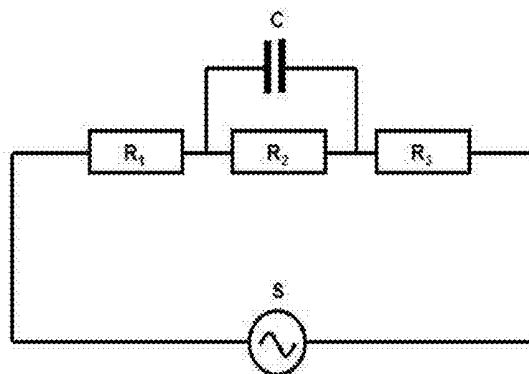

Fig. 7

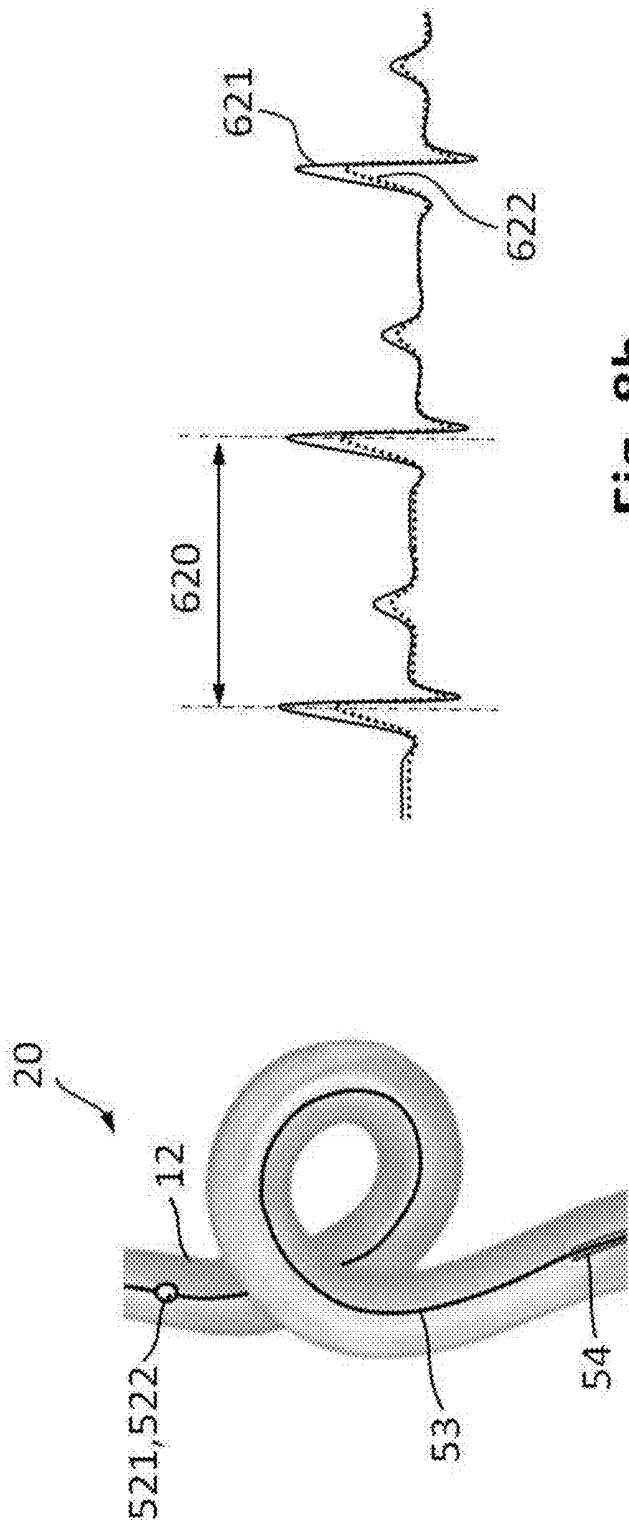

Fig. 8a

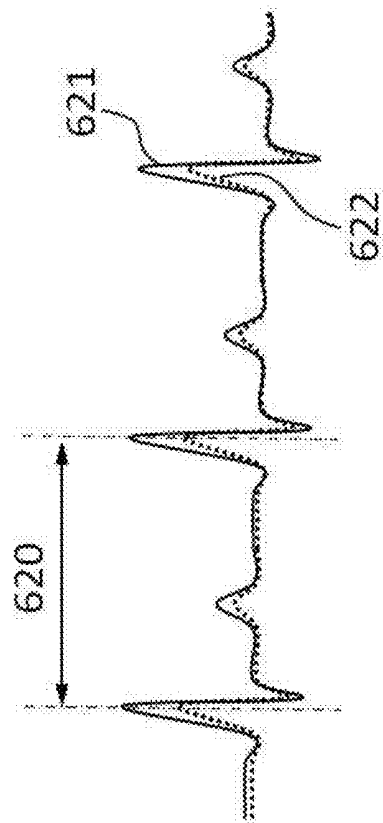

Fig. 8b

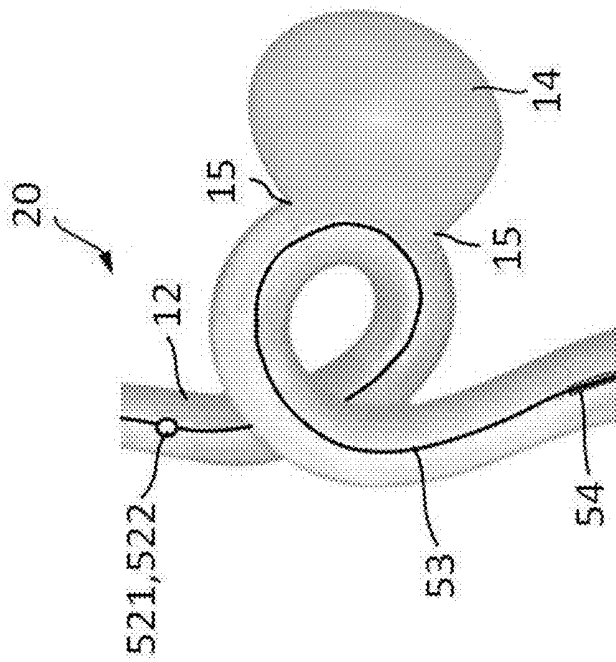

Fig. 9a

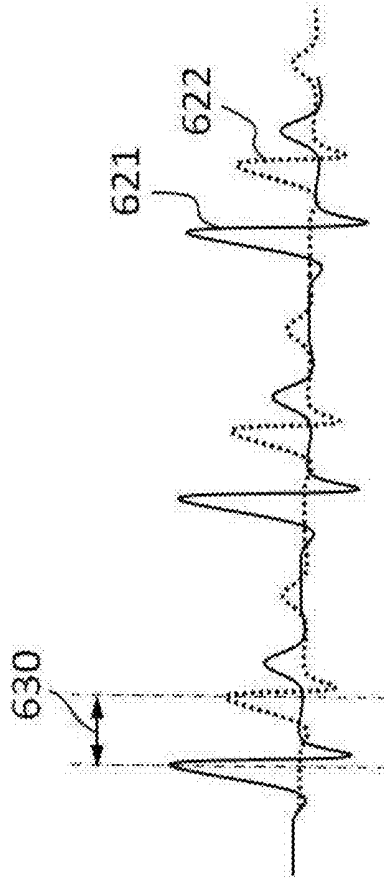

Fig. 9b



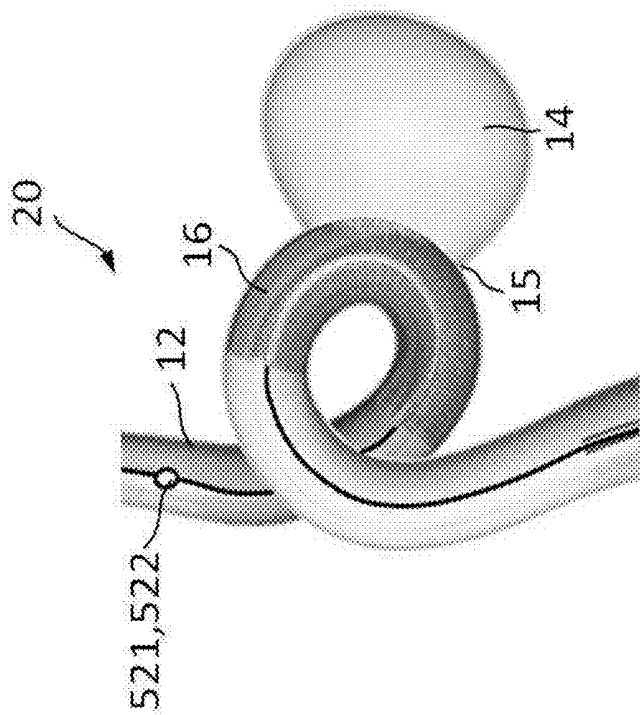

Fig. 10a

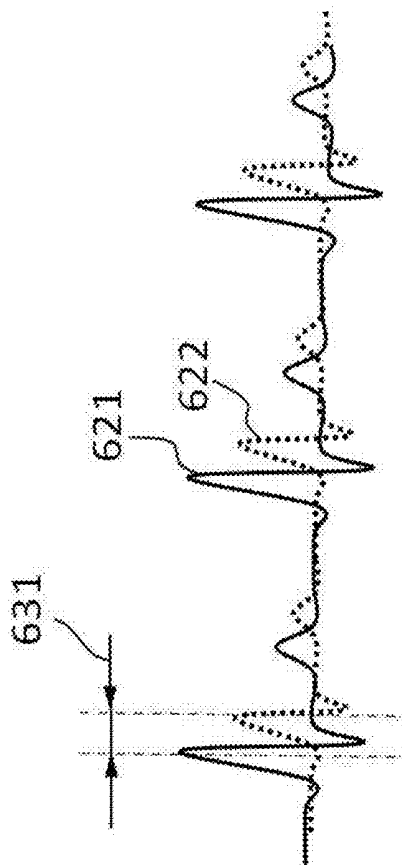

Fig. 10b

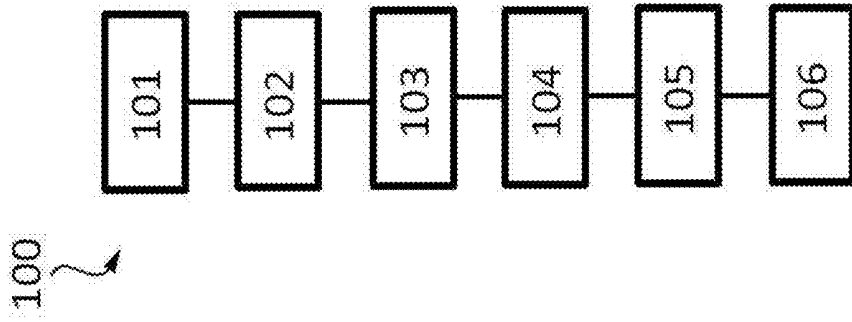

Fig. 12

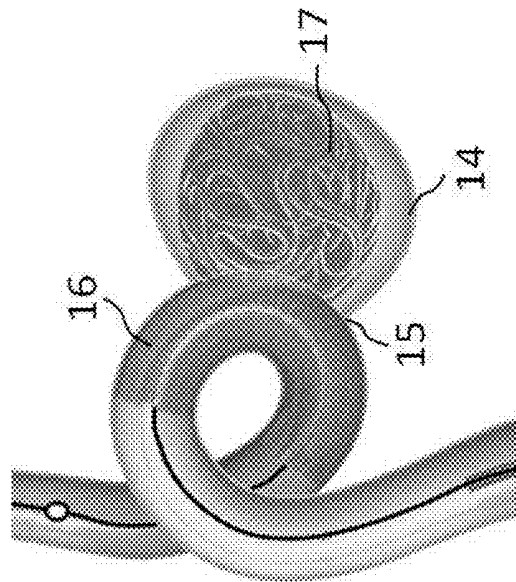

Fig. 11

## APPARATUS FOR CHARACTERIZING A VESSEL WALL

### CROSS-REFERENCE TO PRIOR APPLICATIONS

[0001] This application is a Continuation of application Ser. No. 15/767,778, filed Apr. 12, 2018, which is the U.S. National Phase application under 35 U.S.C. § 371 of International Application No. PCT/EP2016/074118, filed on Oct. 10, 2016, which claims the benefit of European Patent Application No. 15189794.9, filed on Oct. 14, 2015. These applications are hereby incorporated by reference herein.

### FIELD OF THE INVENTION

[0002] The invention relates to an apparatus, a system and a method for measuring physical properties inside a body lumen.

### BACKGROUND OF THE INVENTION

[0003] Weakening of an arterial wall may lead to formation of a bulge on the vessel wall. A large fraction of the population has asymptomatic aneurysms with no further growth of the bulge, presenting low risk for their condition. However, when the aneurysm evolves in size, the arterial wall weakens beyond a critical threshold due to the pressure exerted by the increasing volume of blood, resulting in rupture of the arterial wall and subsequent internal hemorrhage. After formation of an aneurysm, assessment of several physical properties as predictors of the aneurysm growth as well as the dynamic assessment of the physical properties inside the aneurysm pouch are crucial in understanding and predicting progression of the aneurysm and the associated risk of arterial wall rupture. Blood flow pattern assessment and local blood pressure measurements are supporting the physicians in taking a decision whether an aneurysm requires treatment. Typical treatments comprise placing coils into the aneurysm for breaking the flow pattern that is stretching the arterial wall, placement of blood flow diverters in the lumen of the arterial wall for impeding blood flow into the aneurysm, or a combination of the two in various phases of the treatment process.

[0004] Computational Fluid Dynamics (CFD) modeling by integrating patient-specific intravascular blood flow velocity and pressure measurements into computational models of aneurysms before and after treatment with flow-diverting stents is presented in "Cerebral Aneurysms Treated with Flow-Diverting Stents: Computational Models with Intravascular Blood Flow Measurements" by M. Levitt et al., American Journal of Neuroradiology, Vol. 35, issue 1, pages 143-148. The premise of aneurysmal flow diversion is the reduction of blood flow into the aneurysm dome, promoting intra-aneurysmal thrombosis and promoting endothelialization of the stent wall, which reconstructs the parent vessel, excluding the aneurysm. Reduction of hemodynamic stress is believed to be crucial in achieving this goal, and the determination of such stress is an important application of CFD analysis. In the method of hemodynamic stress computation three-dimensional rotational angiography is used, obtained before aneurysm treatment of patients. Contrast-enhanced flat panel Computer Tomography (CT) was obtained for stent visualization after treatment by endovascular flow-diverting stent placement. Blood flow velocity and blood pressure were measured before and after place-

ment of flow-diverting stents by use of a dual-sensor pressure and Doppler velocity guidewire at essentially the same locations. The measurements were exported to a workstation for CFD analysis where the three-dimensional reconstructions of the vessels were created from the rotational angiographic images. A "virtual stent" was placed into each reconstruction for posttreatment simulations by inserting a saddle-shaped surface to the location of the stent boundary on the basis of its location in the posttreatment CT. In accordance with the therapeutic intent of flow-diverting stents, the results of the CFD model showed reduction of flow rate, vessel wall shear stress and shear stress gradient in the aneurysmal domes after treatment.

[0005] US 2005/0197571 A1 discloses an apparatus and method for the measurement of vascular impedance of the ocular circulation in vivo are provided. A pressure pulse waveform is recorded from measurement of the intraocular pressure, and the velocity profile of blood flow in the retrolubar circulation is recorded. These two readings are used to calculate the vascular impedance modulus.

### SUMMARY OF THE INVENTION

[0006] It is an object of the invention to provide an apparatus for improved characterization of a condition of a vessel wall of a living being.

[0007] According to a first aspect of the invention, this object is realized by an apparatus for characterizing a condition of a vessel wall of a living being, the apparatus comprising:

[0008] a processor for processing measurement signals, wherein the apparatus is configured to receive a temporal pressure measurement signal and a temporal flow measurement signal of a pulsatile blood motion within a vessel from at least an instrument trackable by an imaging unit with respect to a morphology of the vessel, and wherein the processor is configured to

[0009] ascertain a phase difference between the temporal pressure measurement signal and the temporal flow measurement signal, indicative of the condition of the vessel wall.

[0010] A phase difference between a pulsatile blood pressure measurement signal and a pulsatile blood flow measurement signal within the vessel appears to be sufficient for a discrimination of a healthy vessel wall from a weakened one. This provides simplicity and an improved indication of vessel wall condition over flow pattern analysis based on CFD using angiographic information.

[0011] In a second aspect of the invention, a system for characterizing a condition of a vessel wall of a living being is presented, the system comprising:

[0012] the apparatus according to the invention,

[0013] the at least an instrument configured for providing the temporal pressure measurement signal of the pulsatile blood motion within the vessel, and

[0014] the imaging unit configured for providing morphological information of the vessel,

[0015] wherein the imaging unit or the at least an instrument is configured for providing the temporal flow measurement signal of the pulsatile blood motion within the vessel.

[0016] The pulsatile blood pressure measurement signal may be provided by a pressure sensor integrated into an interventional instrument, whereas the pulsatile blood flow measurement signal may either be a volumetric flow mea-

surement with a suitable imaging unit or a blood flow velocity measurement provided by a suitable sensor integrated into the interventional instrument. The imaging unit may provide radiographic projections, computed tomography, ultrasound or magnetic resonance based morphological information. A weakened wall segment of the vessel can be identified and tagged on the display by tracking the position of the instrument with respect to the morphology of the vessel, and by knowing the phase difference between the pulsatile blood pressure and the pulsatile blood flow.

[0017] In an embodiment, the system further comprises a display, and the processor is configured for rendering a representation of the phase difference between the temporal pressure measurement signal and the temporal flow measurement signal on the display, indicative of the condition of the vessel wall. The visual representation of the phase difference may be a graphical representation of a superposition of the temporal pressure and flow measurement signals, a value indicating the phase difference in radians or a percentage of the phase difference relative to the period of the pulsatile blood motion.

[0018] In a further embodiment of the system, the processor is configured for rendering a morphological representation of the vessel on the display from the morphological information provided by the imaging unit. The structure of the vessel provides essential information for the physician during navigation of interventional instruments through vessels, in order to reach target sites in remote vasculature, for instance when the sites are located in peripheral and cerebral vasculature.

[0019] In a third aspect of the invention, an instrument for providing temporal pressure and flow measurement signals of a pulsatile blood motion within a vessel is presented, the instrument connectable to the apparatus according to the invention, the instrument comprising a pressure sensor and a flow sensor, wherein the pressure sensor and the flow sensor are located such as to provide temporal pressure and flow measurements in a same transversal plane of the instrument, wherein a position of the instrument is trackable by an imaging unit with respect to a morphology of the vessel. The benefit of using one and the same instrument for blood pressure and blood flow measurement, with sensors located in the same transversal plane of the instrument, is that in the process of ascertaining the phase difference between pulsatile pressure and flow, one can neglect the phase difference offset that would originate from the distance between the two measurement points along the blood vessel.

[0020] In a fourth aspect of the invention, a method of characterizing a condition of the vessel wall of the living being is presented, the method comprising:

[0021] receiving temporal pressure and flow measurement signals of a pulsatile blood motion within a vessel from at least an instrument trackable by an imaging unit with respect to a morphology of the vessel, and

[0022] ascertaining a phase difference between the temporal pressure measurement signal and the temporal flow measurement signal, indicative of a condition of the vessel wall.

[0023] In an embodiment, the method further comprises the step of rendering a representation of the phase difference between the temporal pressure measurement signal and the temporal flow measurement signal on a display, indicative of the condition of the vessel wall. Graphical or numerical

visualization of the phase difference boosts visual interpretation of the results and improves assessment of the condition of the vessel wall segments.

[0024] In a further embodiment, the method comprises the steps of tracking a position of the at least an instrument with respect to the morphology of the vessel, and displaying the position of the at least an instrument on the morphological representation of the vessel. Position tracking of the measurement instrument with respect to the morphology improves the localization of the segments with weakened vessel wall, and provides supporting information for treatment decisions of those segments.

[0025] In yet a further embodiment, the method comprises positioning of the at least an instrument distal to an aneurysm with respect to a direction of the blood motion within the vessel based on tracking the position of the at least an instruments with respect to the morphology of the vessel. The method allows detection of an aneurysm in a vessel and evaluation of potential risks associated to vessel wall weakness.

[0026] In an embodiment, the method further comprises positioning of the at least an instrument distal to a flow diverting stent that is impeding at least partially blood flowing into the aneurysm based on tracking the position of the at least an instruments with respect to the morphology of the vessel. Flow diverting stents reduce hemodynamic stress of the already weak vessel wall of the aneurysm. The partial or complete occlusion of the aneurysm promotes intra-aneurysmal thrombosis and endothelialization of the stent wall. The outcome of flow diverting stent apposition can be efficiently evaluated from the phase difference between the pulsatile blood pressure and pulsatile blood flow measurement signals.

[0027] In a further embodiment, the method is used for vessel comprising coils inside the aneurysm. The long-term clinical outcome assessment of such a treatment and the risk evaluation for growth of the aneurysm based on CFD flow simulations relying on angiography are seriously hindered by the presence of coils in the aneurysm. Therefore, the method offers improved characterization of the condition of the vessel wall after coil placement into the aneurysm.

[0028] In an embodiment of the method, the temporal pressure and flow measurement signals are originating at the same distance from a neck of the aneurysm based on tracking the position of the at least an instruments with respect to the morphology of the vessel. The advantage is that there is no need for compensation for the temporal offset in the phase difference between pressure and flow measurement signals caused by the dissimilar distances between the locations of the pressure and flow measurements with respect to the weakened vessel wall.

[0029] Additional aspects and advantages of the invention will become more apparent from the following detailed description, which may be best understood with reference to and in conjunction with the accompanying drawings.

#### BRIEF DESCRIPTION OF THE DRAWINGS

[0030] In the drawings:

[0031] FIG. 1 shows schematically and exemplarily an embodiment of a system according to the invention.

[0032] FIG. 2 shows schematically and exemplarily an embodiment of an instrument used for characterization of a vessel wall.

[0033] FIG. 3 shows an exemplary embodiment of the distal tip of the instrument.

[0034] FIG. 4 shows an alternative embodiment of the distal tip.

[0035] FIG. 5 shows an exemplary angiographic projection of a vasculature.

[0036] FIG. 6 shows an exemplary three-dimensional vessel morphology representation of a region from the angiographic projection.

[0037] FIG. 7 shows schematically and exemplarily an embodiment of an equivalent electrical circuit of a vasculature network.

[0038] FIG. 8a shows an exemplary vessel morphology representation of a vessel with healthy vessel walls.

[0039] FIG. 8b shows an exemplary representation of a pulsatile blood pressure and a pulsatile blood flow measurement for a vessel with healthy vessel walls.

[0040] FIG. 9a shows an exemplary vessel morphology representation of a vessel comprising an aneurysm.

[0041] FIG. 9b shows an exemplary representation of the pulsatile blood pressure and pulsatile blood flow measurements for a vessel comprising an aneurysm.

[0042] FIG. 10a shows an exemplary vessel morphology representation of a vessel treated by flow diverting stent apposition.

[0043] FIG. 10b shows an exemplary representation of the pulsatile blood pressure and pulsatile blood flow measurements for a vessel treated by flow diverting stent apposition.

[0044] FIG. 11 shows an exemplary vessel morphology representation of a vessel treated by placement of coils into the aneurysm prior to apposition of a flow diverting stent.

[0045] FIG. 12 shows schematically a method for characterizing the condition of the vessel wall of a patient.

#### DETAILED DESCRIPTION OF EMBODIMENTS

[0046] FIG. 1 shows schematically and exemplarily an embodiment of a system 1 according to the invention, used for characterization of a condition of a vessel wall of a living being 2. In this embodiment, the system comprises a radiological imaging unit 3 for acquiring radiological angiographic (RA) projection of the vessel structure of interest upon injection of a contrast agent bolus in the targeted vasculature. The radiological imaging unit 3 comprises an x-ray source 31 for emitting x-rays 32 traversing the person 2 lying on the support means 4. The radiological imaging unit 3 further comprises an x-ray detector 33 for detecting the x-rays 32 after having traversed the person 2. The x-ray detector 33 is adapted to generate detection signals being indicative of the detected x-rays 32. The detection signals are transmitted to a fluoroscopy control unit 34, which is adapted to control the x-ray source 31, the x-ray detector 32 and to generate two-dimensional morphological projection information depending on the received detection signals. The injection of the radiological contrast agent bolus in the targeted vasculature is performed through a lumen of the instrument 5, the lumen extending from the handgrip 51 to the distal tip 52 positioned at the target site in the vasculature. Alternatively, the instrument 5 may be introduced into the vasculature through the lumen of a tubular sheath, and the tubular sheath may be used for injection of the radiological contrast agent. Two-dimensional or three-dimensional morphology of the vasculature can be obtained with various techniques such as: magnetic resonance angiography (MRA) in which the imaging unit 3 is a magnetic

resonance imaging system and the contrast agent is a gadolinium-based substance; ultrasound imaging (UI) in which the vasculature is imaged by using an extracorporeal or intracorporeal ultrasound imaging unit 3 while an echogenic contrast agent comprising microbubbles enhances the visibility of the vessels carrying blood; and computed tomography angiography (CTA) which is similar to RA. The instrument 5, which may be an interventional catheter, further comprises two sensors on its distal portion for providing measurement signals of physical properties of the blood within the vessel. An apparatus 6 receives the measurement signals and is adapted to render representations of the measurement signals or derived quantities on a display 61. The apparatus 6 may further be configured to render a representation of the morphology of the vessel on the display 61.

[0047] FIG. 2 shows an exemplarily embodiment of an instrument 5 used for assessment of the condition of the vessel wall. The instrument comprises a handgrip 51, a tubular elongated shaft 54, an extensible and more flexible shaft 53 reaching distal to the tubular elongated shaft 54, a connection cable 56 and a connector 55 for connecting the instrument to the apparatus 6. Alternatively, the instrument 5 may be only a guidewire comprising the flexible shaft 53, and the cable 56 may be a continuation of the guidewire, terminating at the proximal end with a connector 55 that is connectable to a patient interface module. In the guidewire configuration the instrument 5 is inserted into the vasculature of the patient through the lumen of an introducer sheath comprising the tubular handgrip 51 and the tubular elongated body 54. In the distal end 52 of the instrument 5 two sensors are integrated, a pressure sensor 521 and a flow sensor 522, similar to the configuration of the ComboWire® XT guidewire manufactured by Volcano Corporation. Typical pressure sensors use change of piezoresistive property upon pressure, fluidic transduction of a deflection of a diaphragm to a mechanical or an electrical signal, and capacitive readout of a suspended membrane over a substrate. Flow sensors integrated in interventional medical instruments typically use Doppler effect of ultrasound or laser radiation to measure blood flow velocity in vessels. The ultrasound waves for blood flow velocity measurement may be generated by piezoelectric ceramic (PZT) or plastic (PVDF) materials, as well as by capacitive or piezoelectric micromachined ultrasound transducers (cMUT or pMUT).

[0048] In FIG. 3 an alternative embodiment of the distal tip 52 is schematically illustrated in a partial cross section of the instrument. A cMUT pressure sensor 521 comprising a membrane facing sideward is integrated into the distal tip 52, for allowing blood exerting pressure on the membrane. A piezoelectric ultrasound transducer 522 facing distal to the instrument is integrated for flow velocity measurement in the axial direction. A transversal plane 526 is defined by the longitudinal axis 525 of the cMUT pressure sensor. The sensors measure blood flow velocity and blood pressure in the same transversal plane 526 of the instrument 5, hence by placing the instrument into a vessel lumen then also in a single transversal plane of the vessel.

[0049] An alternative embodiment of the distal tip 52 is schematically presented in FIG. 4. The piezoresistive pressure sensor 521 is integrated such that it measures blood pressure in a transversal plane 526 comprising the distal end 527 of the instrument 5. The pulsatile blood flow velocity is measured with an optical sensor comprising an optical fiber

**523** integrated into the instrument. In this embodiment, the apparatus comprises a source for generating laser radiation that is transmitted through the optical fiber **523** to the distal portion **52** of the instrument. An optically transparent cavity **528** may separate the distal end of the optical fiber from the distal end **527** of the instrument. The cavity **528** may be of glass, transparent plastic or a compartment filled with optically transparent fluid. The apparatus **6** shown in FIG. **1** comprises a detector which detects the optical signals reflected back from the moving blood, and the processor derives the blood flow velocity from the frequency shift of the received laser radiation with respect to the transmitted one. Alternatively, the optical fiber **523** can be used for pressure measurement when the optically transparent cavity comprises a flexible membrane at the distal end **527** of the instrument. The pressure exerted on the distal end of the instrument causes a deflection of the membrane, and the optical path change of the laser reflection from the membrane is a measure of the exerted pressure for a known bending stiffness of the membrane. The optical path change may be measured by interferometry, wherein the reference optical path is defined by the reflection from the distal end of the optical fiber **823**, and the changing optical path is defined by the reflection from one of the surfaces (internal or external) of the membrane closing the cavity at the distal end **527** of the instrument. As a further alternative, the single optical fiber **523** and the cavity **528** sealed by the membrane at the distal end **527** of the instrument **5** may be used simultaneously for blood pressure and blood flow velocity measurements, the deflection of the semitransparent membrane is the measure of the blood pressure exerted on the membrane, and the frequency shift of the laser radiation resulting from the motion of the blood distal to the instrument **5** is the measure of the blood flow velocity.

**[0050]** Although the pulsatile blood pressure has to be measured locally in the lumen of the vessel, the pulsatile blood flow can be derived from RA, CTA, MRA and UI. As an example, the pulsatile blood flow derived from RA is disclosed in Bonnefous et al, "Quantification of arterial flow using digital subtraction angiography", Medical Physics, Vol. 39, No. 10, p. 6264-75, 2012. The technique involves injection of iodine contrast medium at a very modest rate (e.g. 1.5 ml/s) into the vessel. As a consequence, the contrast agent is modulated by the flow pulsatility at the injection point driven by the cardiac cycle. The contrast is denser during the diastole phase and less dense during the systole phase. The modulated contrast agent pattern travels through the vessels. In the x-ray image, the contrast agent patterns can be followed along the vessel trajectory using an optical flow algorithm. By matching a 3D reconstruction of the vessel tree (e.g., obtained by 3D-RA) with the x-ray images, foreshortening can be taken into account, and the vessel diameters can be calculated. To determine the flow, the low frequent in- and out-flow of contrast medium is separated from the high frequent pulsatile components. The flow measurements need to be temporally synchronized to the pressure measurements from the instrument **5**, which can be realized by synchronizing the injection of the contrast agent into the vessel with the pressure measurement. Optionally, it is possible to inject the contrast agent with the same system that measures the blood pressure (e.g. one unified guiding catheter/pressure guidewire assembly).

**[0051]** FIG. **5** shows an angiographic projection **10** of a branching vessel, with a left branch **11** and a right branch **12**.

The right branch **12** comprises a loop and a bulge in the region **13** marked with a circle, for the exemplary description of the invention. A magnified three-dimensional vessel morphology representation **20** of the region **13** is reconstructed based on angiographic projections, which shows in FIG. **6** that the right vessel branch **12** comprises a region with weakened vessel wall that led to formation of an aneurysm **14**. Typically, the aneurysm presents a circumferential neck **15**, which represents the segment of weakened vessel wall. The three-dimensional model may further allow the possibility to customize a flow diverting stent **16** for treatment planning.

**[0052]** The vascular system can be represented in a simplified form as an equivalent electrical circuit of resistors and capacitors, whereby the vessels are represented by resistors and the aneurysms are represented by capacitors. The resistance of a single vessel is determined by its radius and its length. A vessel network can be collapsed into a single resistor. The capacity of the aneurysm is determined by its volume, its neck **15** area and its position. A vascular network with an aneurysm can be modelled as illustrated in FIG. **7**. The oscillating source **S** represents the heart, which is the source of the periodic blood pressure with electrical equivalence of a potential, and the periodic blood flow with electrical equivalence of a current. Resistors  $R_1$ ,  $R_2$  and  $R_3$  represent the resistance of the entire vascular network proximal to the aneurysm, the resistance of the vessel segment that holds the aneurysm **14**, and the resistance of the entire vascular network distal to the aneurysm, respectively. Capacitor **C** models the influence of the aneurysm **14** on the blood flow. The complexity of the network may further be increased by addition of elements to the equivalent electrical circuit.

**[0053]** For a healthy vessel wall, schematically illustrated in FIG. **8a**, the capacitor **C** is missing from the electrical network, due to the absence of an aneurysm. The blood pressure and blood flow are measured at the position of the sensors **521** and **522** in the vessel **12** with the instrument **5**. Alternatively, the blood flow can be derived for the position of the blood pressure sensor from RA, CTA, MRA or UI, in which case the instrument **5** comprises only the pressure sensor **521**, and the blood flow measurements are temporally synchronized to the pressure measurements. For a healthy vessel segment the current and the potential representing the blood flow and the blood pressure respectively, are in phase across the resistor  $R_2$ , as exemplarily illustrated in FIG. **8b**. The pulsatile motion with a period **T 620** is generated by cyclical heartbeat. The continuous line **621** represents the temporal blood pressure measurement signal and the dotted line **622** represents the temporal blood flow measurement signal.

**[0054]** FIG. **9a** shows an example of an aneurysm **14** formed due to a weakened segment of the vessel wall. The position of the distal tip **52** comprising the sensors **521,522** is distal to the aneurysm with respect to the direction of blood flow. Preferably, the measurement signals originate at the same distance from the neck **15** of the aneurysm **14**, which can be provided with one of the embodiments of the instrument **5** shown in FIGS. **3, 4** or by a typical pressurewire (e.g. Verrata® Pressure Guide from Volcano Corporation) and one of the modalities from RA, CTA, MRA and UI used for deriving pulsatile blood flow.

**[0055]** The presence of the aneurysm causes a phase difference  $\Delta t$  **630** between the measured blood pressure **621**

and measured blood flow **622**, as illustrated in FIG. **9b**, similar to the phase difference between the potential and current measured between the resistors  $R_2$  and  $R_3$  in the equivalent electrical circuit. The measure of the phase difference is indicative of the condition of the vessel wall, hence the size of the aneurysm. For detection of the phase difference **630** it is not essential to accurately measure the absolute values of pulsatile blood pressure and pulsatile blood flow, since the pulsatility is easily derivable from relative blood pressure and blood flow measurement signals. Therefore, calibration of the measurements is not necessary, which is a major advantage of the technique.

[0056] Typical treatment of an aneurysm is flow diverting stent apposition into the vessel, such that the weakened vessel segment and adjacent portions proximal and distal to the weakened segment are covered and protected from further weakening. FIG. **10a** shows an example of a stent **16** limiting blood flowing into the aneurysm **14**. The stent prevents in the first instance the evolution of the aneurysm to a larger size, leading to increased risk of aneurysm rupture, and secondly, it permits the blood already present within the aneurysm to clot and form further protection of the already weak vessel wall. Placing a flow diverting stent **16** reduces the capacitance  $C$  of the aneurysm in the equivalent electrical circuit, with the consequence that the phase difference between the potential and the current reduces. FIG. **10b** shows the effect of a flow diverting stent apposition on the measured blood pressure **621** and blood flow **622**. The change of the phase difference prior and post flow diverting stent apposition (**630** compared to **631**) is a measure of stent placement efficacy, as an incorrectly placed stent has less impact on the capacitance  $C$  of the aneurysm **14**. The expected outcome of the treatment is that the aneurysm stops evolving, and the clotted blood completely blocks and protects the wall of the aneurysm. Therefore, in a follow-up examination of the patient, the phase difference **631** is expected to further decrease, potentially showing no phase difference after a longer duration.

[0057] An alternative, but less efficient treatment of the aneurysm is placement of multiple coils within the aneurysm, with the intent to limit blood flowing into the aneurysm by decreasing the available volume of the aneurysm pocket. In case that the treatment is not successful and the aneurysm keeps evolving in size, flow diverting stent apposition is necessary. The coil placement is just very locally addressing the problem, whereas the flow diverting stent protects vessel wall segments proximal and distal to the aneurysm, which might also exhibit poor condition. An example of an aneurysm **14** treated by placement of coils **17** prior to flow diverting stent **16** apposition is shown in FIG. **11**, wherein the aneurysm in the vessel model has been partially sectioned for making coils **17** visible in the illustration.

[0058] Once the processor ascertains the phase difference **630**, **631** between the measured pulsatile blood pressure **621** and pulsatile blood flow **622** signals, the processor may render a graphical representation as presented in FIGS. **8b**, **9b**, **10b** on the display **61** integrated into the apparatus **6**, or on a separate screen available for the physician. Alternatively or additionally, the display may present values corresponding to the phase difference  $\Delta t$ , or a percentage of the phase difference with respect to the period  $T$  between consecutive heartbeats. The processor may render on the display **61** a morphological representation **20** of the vessel

structure from information received from the imaging unit **3**. The imaging unit **3** may further provide information on the position of the instrument **5** with respect to the morphology of the vasculature. Tracking of the distal tip **52** of the instrument **5** in RA or in CTA can be achieved by using radiological marker integrated into the distal tip. Alternatively, in UI the tracking of the position of the instrument **5** can be realized by integrating active ultrasound sensor into the distal tip. The ultrasound sensor transmits ultrasound waves from within the vessel through the body of the patient **2** and a portion of the ultrasound signal is received by the intracorporal or extracorporal ultrasound imaging unit **3**, which is also providing the morphological information of the target vasculature in its field of view, enabling continuous localization of the distal tip **52** within the vessel morphology. Visualization of the position of the sensors **521**, **522** and/or instrument **5** on the morphological representation **20** may be illustrated as in FIGS. **8a**, **9a**, **10a**. A weakened segment of the vessel wall can be identified and tagged on the display by tracking the position of the instrument with respect to the morphology of the vessel, and by knowing the phase difference between the pulsatile blood pressure and the pulsatile blood flow.

[0059] FIG. **12** illustrates schematically a method **100** of characterizing the condition of the vessel wall of a patient. In step **101** the apparatus **6** receives temporal pressure **621** and flow **622** measurement signals of a pulsatile blood motion within the vessel, and in step **102** the processor of the apparatus **6** ascertains the phase difference **630**, **631** between the pulsatile blood pressure measurement signal **621** and the pulsatile blood flow measurement signal **622**, indicative of the condition of the vessel wall. Preferably, the sensors providing the measurement information are integrated into the instrument **5** as shown in FIGS. **3** and **4**, such as to provide blood pressure **621** and blood flow **622** measurements in the same transversal plane **526** of the instrument. The pressure and blood flow measurements may alternatively be performed with an instrument as shown in FIG. **2**, where the two sensors are not providing measurements in the same transversal plane of the vessel. As a consequence, the measurement of either the blood pressure or that of the blood flow has to be compensated for the phase offset originating from the known distance between the two sensors **521**, **522** integrated into the distal tip **52**. Alternatively, two different instruments may be inserted into the vessel, each one comprising a single sensor, hence the pressure measurement can be carried out with a pressurewire (e.g. Verrata® from Volcano Corporation), and the blood flow can be measured with a Doppler guidewire (e.g. FloWire® from Volcano Corporation). In an embodiment of the method, the pressure is measured with a pressurewire and the blood flow is measured with an imaging unit **3** related to one of the blood flow imaging modalities RA, CTA, MRA, UI. The method further comprises the step **103** of rendering a representation of the phase difference **630** between the pulsatile blood pressure measurement signal **621** and the pulsatile blood flow measurement signal **622** on a display **61**, indicative of the condition of the vessel wall. In step **104** the processor of the apparatus **6** is configured to render a morphological representation **20** of the vessel on the display **61** from the morphological information provided by the imaging unit **3**. In step **105** the imaging unit **3** is tracking the position of the instrument **5** with respect to the morphology

of the vessel, and in step **106** the position of the instrument **5** is displayed on the morphological representation **20** of the vessel.

**[0060]** In an embodiment of the method **100**, the temporal pressure **621** and flow **622** measurement signals originate from a vessel comprising an aneurysm **14** in the vessel wall, and the measurement signals originate distal to the aneurysm **14** with respect to a direction of the blood flow. Measurements proximal to the aneurysm would potentially show no phase difference between the pulsatile pressure and blood flow, indicative of healthy vessel wall, unless yet another aneurysm is present proximal to the respective measurement location. The method allows detection of vessel wall weakness along the vessel during pullback of the instrument **5** comprising both pressure and flow sensors, or by pulling back the instrument comprising only the pressure sensor and by measuring the blood flow with the imaging unit **3** along the tracked trajectory of the pulled back instrument. The pullback rate should be such to allow sufficient time to determine the potential presence of phase difference **630** in the discrete measurement locations along the pullback trajectory of the instrument.

**[0061]** In an embodiment, the method **100** is used for assessing the efficacy of flow diverting stent **16** apposition. The flow diverting stent obstructs at least partially blood flowing into the aneurysm in order to reduce the cyclical pressure stretching the aneurysm wall. Reduction of blood flow into the aneurysm also promotes intra-aneurysmal thrombosis. An accurate apposition of the flow diverting stent is detectable by a significant reduction of post apposition phase difference **631** between the pulsatile pressure **621** and pulsatile blood flow **622** measurement signals with respect to the phase difference **630** prior to stent apposition.

**[0062]** The method **100** may be used for assessing efficacy of flow diverting stent **16** apposition after an initial treatment of coil **17** placement into the aneurysm **14**. A potential weakness of the treatment with coils is that on a longer term the vessel wall in the vicinity of the initial neck **15** of the aneurysm may further weaken. A correctly appositioned stent protects the neck **15** of the aneurysm **14** and also the vessel wall in the vicinity proximal and distal to the aneurysm neck **15**.

**[0063]** In an embodiment of the method **100**, the temporal pressure **621** and flow **622** measurement signals preferably originate at the same distance from the neck **15** of the aneurysm **14**, with the advantage that there is no temporal offset caused by the dissimilar distances between the locations of the pressure and blood flow measurements with respect to the aneurysm neck **15**.

**[0064]** Although medical device was used in the exemplary description of the invention, that should not be construed as limiting the scope.

**[0065]** Other variations to the disclosed embodiments can be understood and effected by those skilled in the art in practicing the claimed invention, from a study of the drawings, the disclosure, and the appended claims.

**[0066]** A single unit or device may fulfill the functions of several items recited in the claims. The mere fact that certain measures are recited in mutually different dependent claims does not indicate that a combination of these measures cannot be used to advantage.

**[0067]** In the claims, the word “comprising” does not exclude other elements or steps, and the indefinite article “a” or “an” does not exclude a plurality.

**[0068]** Any reference signs in the claims should not be construed as limiting the scope.

1. An instrument configured for insertion into a vessel, the instrument comprising:

a pressure sensor configured to provide temporal pressure measurement signals of pulsatile blood motion within the vessel; and

a flow sensor configured to provide temporal flow measurement signals of the pulsatile blood motion within the vessel,

wherein the pressure sensor and the flow sensor are located on the instrument to provide the temporal pressure measurement signals and the temporal flow measurement signals in a same transversal plane of the instrument.

2. A system comprising:

the instrument according to claim 1; and

an apparatus for characterizing a condition of a vessel wall, wherein the instrument is connectable to the apparatus.

3. The system of claim 2, wherein the apparatus comprises a processor configured to process the temporal pressure measurement signals and the temporal flow measurement signals, the processor is configured to:

receive the temporal pressure measurement signals and the temporal flow measurement signals of the pulsatile blood motion within the vessel;

ascertain a phase difference between the temporal pressure measurement signals and the temporal flow measurement signals; and

detect, by the phase difference, a condition of a segment of the vessel wall.

4. The system according to claim 3, wherein:

the instrument is configured to acquire the temporal pressure measurement signals and the temporal flow measurement signals along a trajectory of the instrument during a pullback motion within the vessel; and

the processor is configured to ascertain the phase difference between the temporal pressure measurement signals and the temporal flow measurement signals at discrete measurement locations along the trajectory of the instrument.

5. The system according to claim 3, further comprising a display, and wherein the processor is configured to render a representation of the phase difference between the temporal pressure measurement signals and the temporal flow measurement signals on the display, indicative of the condition of the vessel wall.

6. The system according to claim 3, further comprising an imaging system configured to provide morphological information of the vessel and to track a position of the instrument with respect to a morphology of the vessel.

7. The system according to claim 6, further comprising a display, and wherein the processor is configured to output to the display the detected condition of the segment of the vessel wall with respect to a morphological representation of the vessel.

8. The system according to claim 7, wherein the processor is configured to output to the display the position of the instrument on the morphological representation of the vessel.

9. A method of characterizing a condition of a vessel wall, the method comprising:



- inserting an instrument into a vessel;  
 receiving temporal pressure measurement signals of a pulsatile blood motion within the vessel from the instrument;  
 receiving temporal flow measurement signals of the pulsatile blood motion within the vessel from the instrument, wherein the temporal pressure measurement signals and the temporal flow measurement signals are received in a same transversal plane of the instrument;  
 ascertaining a phase difference between the temporal pressure measurement signals and the temporal flow measurement signals; and  
 detecting, by the phase difference, a condition of a segment of the vessel wall.
- 10.** The method according to claim **9**, further comprising:  
 receiving the temporal pressure measurement signals and the temporal flow measurement signals of the pulsatile blood motion within the vessel from the instrument along a trajectory of the instrument during a pullback motion within the vessel; and  
 ascertaining the phase difference between the temporal pressure measurement signals and the temporal flow measurement signals, indicative of the condition of the segment of the vessel wall, at discrete measurement locations along the trajectory of the instrument.
- 11.** The method according to claim **9**, further comprising:  
 rendering a representation of the phase difference between the temporal pressure measurement signals and the temporal flow measurement signals on a display, indicative of the condition of the segment of the vessel wall.
- 12.** The method according to claim **9**, further comprising:  
 providing morphological information of the vessel; and  
 tracking a position of the instrument with respect to a morphology of the vessel.
- 13.** The method according to claim **12**, further comprising:  
 rendering, on a display, a representation of the detected condition of the segment of the vessel wall with respect to a morphological representation of the vessel.
- 14.** The method according to claim **12**, further comprising:  
 displaying, on a display, the position of the instrument with respect to a morphological representation of the vessel.
- 15.** The method according to claim **12**, further comprising:  
 positioning the instrument distal to an aneurysm with respect to a direction of the pulsatile blood motion within the vessel based on tracking the position of the instrument with respect to the morphology of the vessel.
- 16.** The method according to claim **15**, further comprising:  
 positioning the instrument distal to a flow diverting stent impeding at least partially blood flowing into the aneurysm based on tracking the position of the instrument with respect to the morphology of the vessel.
- 17.** The method according to claim **16**, wherein the method is used for the vessel comprising coils inside the aneurysm.
- 18.** A non-transitory computer-readable storage medium having stored a computer program comprising instructions, the instructions, when the computer program is executed by a computer, cause the computer to:  
 receive temporal pressure measurement signals of a pulsatile blood motion within a vessel from an instrument inserted into the vessel;  
 receive temporal flow measurement signals of the pulsatile blood motion within the vessel from the instrument, wherein the temporal pressure measurement signals and the temporal flow measurement signals are received in a same transversal plane of the instrument;  
 ascertain a phase difference between the temporal pressure measurement signals and the temporal flow measurement signals; and  
 detect, by the phase difference, a condition of a segment of the vessel wall.

\* \* \* \* \*