

Wireless Technologies in Future Aircraft

Citation for published version (APA):

Souftas, A. (2021). *Wireless Technologies in Future Aircraft*. Technische Universiteit Eindhoven.

Document status and date:

Published: 09/09/2021

Document Version:

Publisher's PDF, also known as Version of Record (includes final page, issue and volume numbers)

Please check the document version of this publication:

- A submitted manuscript is the version of the article upon submission and before peer-review. There can be important differences between the submitted version and the official published version of record. People interested in the research are advised to contact the author for the final version of the publication, or visit the DOI to the publisher's website.
- The final author version and the galley proof are versions of the publication after peer review.
- The final published version features the final layout of the paper including the volume, issue and page numbers.

[Link to publication](#)

General rights

Copyright and moral rights for the publications made accessible in the public portal are retained by the authors and/or other copyright owners and it is a condition of accessing publications that users recognise and abide by the legal requirements associated with these rights.

- Users may download and print one copy of any publication from the public portal for the purpose of private study or research.
- You may not further distribute the material or use it for any profit-making activity or commercial gain
- You may freely distribute the URL identifying the publication in the public portal.

If the publication is distributed under the terms of Article 25fa of the Dutch Copyright Act, indicated by the "Taverne" license above, please follow below link for the End User Agreement:

www.tue.nl/taverne

Take down policy

If you believe that this document breaches copyright please contact us at:

openaccess@tue.nl

providing details and we will investigate your claim.

Executive Board

Navigation address: De Zaale, Eindhoven
P.O. Box 513, 5600 MB Eindhoven
The Netherlands
www.tue.nl

Author
Asterios Souftas

Graduation Date
September 2021

PDEng Examination final report

Wireless Technologies in Future Aircraft

Department: Electrical Engineering
Research group: Electro-optical communication
Author: A.Souftas, MSc.
Supervisors: Prof. S. Heemstra de Groot
Mr. K. Nuyten
dr. I. Niemegeers
dr. G. Exarchakos

Thesis Evaluation Committee

Chair: dr. B. P. de Hon
Members: Prof. S. Heemstra de Groot
Mr. K. Nuyten
dr. R. Serra
dr. U. Johannsen
dr. A.J. Hoeven

Table of contents

| | | | |
|--|--|--|-----------|
| Title | | | |
| Wireless Technologies in Future Aircraft: Final report | | | |
| | Executive Summary | | 3 |
| | 1 Introduction | | 5 |
| | 1.1 Project overview | | 6 |
| | 1.2 Cause for unreliability in wireless EIS networks | | 6 |
| | 1.3 Demonstrator design scope | | 7 |
| | 1.4 Demonstrator design delimitations | | 7 |
| | 2 Concept exploration and analysis | | 8 |
| | 2.1 Current wired avionics system | | 8 |
| | 2.2 Wireless technologies and methods | | 9 |
| | 2.2.1 Operating frequency | | 10 |
| | 2.2.2 Considered Wireless protocols | | 10 |
| | 2.2.3 Wireless Reliability Mechanisms | | 10 |
| | 2.3 Identifying the demonstrator design space | | 11 |
| | 3 Requirements | | 12 |
| | 4 Demonstrator design strategy | | 14 |
| | 4.1 Project management framework | | 14 |
| | 4.2 Implementation schedule | | 15 |
| | 4.3 Deployed Wireless Technologies | | 16 |
| | 4.3.1 Hardware and software | | 17 |
| | 4.4 Demonstrator architecture | | 18 |
| | 4.4.1 Design for reliability | | 19 |
| | 4.4.2 Reliability mechanisms Trade-off analysis | | 22 |
| | 5 Demonstrator implementation | | 24 |
| | 5.1 Phase 1 – Point-to-Point communication | | 24 |
| | 5.2 Phase 2 – ARINC 429 word generation | | 24 |
| | 5.3 Phase 3 – Packet sniffer | | 26 |
| | 5.4 Phase 4 – Increased network size | | 28 |
| | 5.5 Phase 5 - Applied reliability mechanism | | 29 |
| | 6 Demonstrator evaluation | | 32 |
| | 6.1 Test setup and results | | 32 |
| | 6.2 Demonstrator verification | | 37 |
| | 6.3 Demonstrator validation | | 38 |
| | 7 Conclusions and recommendations | | 42 |
| | 8 References | | 43 |

Executive Summary

In recent years, the priorities of aircraft system design have changed. Engineers and researchers are continuously trying to decrease the carbon emissions of modern aircraft. To satisfy the demand for sustainable aviation, Fokker Elmo aims to design lighter Electrical Interconnection System (EIS) networks. Wireless technologies are a disruptive candidate to contribute to the ambitious target of greener aviation.

A wireless approach to EIS network design has significant benefits. A (partly) wireless EIS network has the potential to decrease aircraft weight, improve system re-configurability through installation flexibility and enable new applications like monitoring moving parts (e.g., the landing gear). Furthermore, an EIS network that is (partly) wireless is capable of mitigating common mode failures, potentially even increasing system reliability. However, wireless technologies do not have a track record in EIS networks and it is not clear if they can meet the strict safety requirements that avionics have to comply to.

The objective of this project is to explore wireless technologies to develop a substantiated vision on wireless applications in future aircraft and develop a demonstrator network that supports this vision. This report is focused on summarizing the work done in the design of the demonstrator network.

To ground the design of the demonstrator network, current trends in avionics design were analyzed. The assumed EIS architecture is based on the Integrated Modular Avionics (IMA) design paradigm. The applied IMA communication chain considers packets generated at sensors, that traverse through a backbone network to reach the aircraft's computers. It was decided that the wireless demonstrator will attempt to replicate the link between sensors and the backbone network.

Consequently, the requirements of the wireless demonstrator were derived from the requirements of a well-known wired protocol with similar scope, ARINC 429. Demonstrator requirements include a worst-case end-to-end latency less than 30 ms and a Packet Reception Ratio (PRR) better than 99.99%.

To implement this design, the incremental approach was preferred. This made it easy to adapt to changing design goals. A variant of the IEEE 802.15.4 protocol, Time Slotted Channel Hopping (TSCH) was selected to implement the demonstrator network. The selection was based on TSCH's accessibility, adaptability and emphasis on the core design goals of high Packet Reception Ratio (PRR) and low latency.

The demonstrator network was successfully implemented. Test results indicated that all requirements were fulfilled except for latency. Based on a theoretical analysis, it was concluded that unexpected delays occur due to the contention-based Medium Access Control approach of the demonstrator. It is expected that implementing a scheduler will improve worst-case latency to be within the requirements.

Overall, the demonstrator showed that the applied network protocols and architecture can feasibly support a wireless EIS network. The selected wireless technology allows for the design of networks that can at best satisfy the requirements of systems that require Development Assurance Level (DAL) specification C (failure rate $10^{-5}/h$). Further effort should be spent on EIS architecture standardization.

List of Abbreviations

ARINC: Aeronautic Radio Incorporated
COTS: Commercial Of The Shelf
CRDC: Common Remote Data Concentrator
CWTe: Center for Wireless Technology Eindhoven
DAL: Development Assurance Level
DoS: Denial of Service
DEES: Design of Electrical Engineering Systems
DIMA: Distributed Integrated Modular Avionics
ECO: Electro-Optical Communications
EIRP: Equivalent Isotropic Radiated Power
EIS: Electrical Interconnection System
EMC: Electromagnetic Compatibility
EWIS: Electrical Wiring Interconnection System
ICAO: International Civil Aviation Organization
IMA: Integrated Modular Avionics
NLR: National Aerospace Laboratory
PDEng: Professional Doctorate in Engineering
PRR: Packet Reception Ratio
QOS: Quality of Service
RA: Radio Altimeter
RDC: Remote Data Concentrator
SARP: Standards And Recommended Practices
TSCH: Time Slotted Channel Hopping
TU/e: Technical University Eindhoven
WAIC: Wireless Avionics Intra Communications
WAIC: Wireless Intra Avionics Communications
WARINC 429: Wireless ARINC 429

1 Introduction

The aviation industry is currently looking at ways to make modern aircraft more efficient. Taking into consideration the political background (ecology) and the potential competitive advantage, the industry is trying to decrease the weight of the aircraft wiring. Doing so will lower the flight carbon footprint and decrease fuel costs resulting in important savings.

In light of this ambition, Fokker Elmo considers redesigning the Electrical Interconnection System (EIS). Most functions of modern aircraft (flight controls, in flight entertainments and everything in between) rely on a reliable wired network.^[1] The design of such a wired network is a complicated process involving cable harness and connector design, aircraft geometry and physical redundancy. These support structures, on top of making installation and maintenance more difficult, have an important impact to the total weight of an aircraft. For example, in a modern airliner like the Airbus A220 (~ 120 seats) the EIS is responsible for 6% of the operational empty weight (incl. support structures)^[2].

To achieve the goal of sustainable aviation, it is necessary to expand the EIS design toolbox. Fokker Elmo and other industry experts are re-thinking the design approach to EIS design. Some of the proposed solutions include optimized architectures, optical networks, power-line communications and wireless technologies.

In the context of the PDEng assignment the feasibility of a wireless approach to EIS design is investigated. Utilizing wireless technology to facilitate intra aircraft communications seems a promising solution, as it can potentially decrease the weight of the EIS. The expectation is that wireless technologies can help reduce the environmental impact while resulting in a network that is easier to deploy and re-configure.

Regardless of the applied technology, all avionics systems must fulfil the industry's safety requirements. The successful deployment of a wireless EIS network relies on being able to match, if not improve, the performance characteristics of current (wired) EIS networks. This specifically applies to critical safety requirements such as reliability and bounded latency.

To identify the design space of such a reliable wireless EIS network, three reports were produced. The respective appendix sections are:

1. "Report on aircraft industry ambitions and roadmaps" (Appendix A).
2. "State of the art in enabling wireless technologies" (Appendix B).
3. "Wireless Avionics and Radio altimeter: Coexistence report:" (Appendix C).

This work was used as input to the demonstrator design. Information from these reports that is relevant to the demonstrator's design will be shared in Chapter 2 "Concept exploration and analysis".

Three more reports were formulated after important demonstrator design milestones. In this work, important aspects of the demonstrator design are explained. The respective appendix sections are:

1. "Definition of aircraft application and system requirements" (Appendix D).
2. "Options for a proof-of-concepts demonstrator" (Appendix E).
3. "Definition of proof-of-concepts demonstrator" (Appendix F).

This report is a technical document that describes the design process of the wireless demonstrator network. The intent is this document will offer technical insight towards the feasibility of a wireless EIS network design.

The report is broken down to three parts:

- The Preparation phase.
 - Chapter 2, concept exploration.
 - Chapter 3, demonstrator requirements.
- Implementation phase
 - Chapter 4, the demonstrator design strategy.
 - Chapter 5, the implementation of the demonstrator design.
- Demonstration and evaluation
 - Chapter 6, test results and evaluation.
 - Chapter 7, conclusions and future recommendations.

1.1 Project overview

The goal of this project was to investigate the feasibility of an EIS based on wireless technologies. A demonstrator wireless network has been designed and implemented. The objective of the demonstrator is to show that an existing functionality of a wired EIS system can be replaced or even improved by wireless technology. The demonstrator will serve as a proof-of-concept system (TRL 3).

This project is executed in cooperation with Fokker Elmo and the Center for Wireless Technology (CWTe) of TU Eindhoven. Fokker Elmo and CWTe are the project stakeholders. This report is intended to be read

With this project, Fokker Elmo's ambition was to:

- Identify the pros and cons of the wireless approach.
- Gain insight of how a wireless solution could be integrated to their business.
- Be able to estimate future expectations in terms of architecture design and industrialization.

1.2 Cause for unreliability in wireless EIS networks

EIS networks must be robust and fulfil stringent safety requirements. The most important requirements are reliable packet reception and real-time functionality (low, bounded delay). To achieve this performance, extra care must be given in the design of a wireless network. The most important causes for unreliability in wireless networks are:

- **Interference.** A wireless network usually operates in an environment outside the control of its designer. Due to transmissions from other networks or systems operating in the same frequency band the signal can be disrupted resulting in packet loss.
- **Collisions.** When network nodes try to transmit at the same time, a collision will occur and both packets will be dropped.
- **Propagation phenomena.** Due to reflections, scattering, refraction, shadowing and diffraction the transmitted signal can be distorted resulting in errors in reception. When the radio signal reaches the receiving antenna by more than one path, this phenomenon is called multipath propagation and can further decrease signal quality.

- **Malicious attacks.** Since a wireless network is accessible to everyone, the network is prone to malicious attacks. Such attacks can range from jamming and Denial of Service (DoS) attacks to sophisticated spoofing attacks.
- **Hardware failure.** Similar to wired networks, the equipment of a wireless network can fail. This can happen due to environmental reasons (strong vibrations, fire hazards, extreme temperature etc.) or due to natural deterioration.

1.3 Demonstrator design scope

The demonstrator network will be used to evaluate a subset of the identified wireless architectures and protocols. The design includes understanding modern EIS architecture and selecting a part of the intra-communication chain that is interesting to the stakeholders and is feasible to develop. The demonstrator will function as a small scale wireless network version that supports an aircraft application. To meet the application's requirements the appropriate mitigation techniques, architectures and protocols will be applied. The scope was jointly defined with the stakeholders to accommodate a novel demonstrator design and formulate the design problem (chapters 2 and 3).

1.4 Demonstrator design delimitations

Due to the limited time and resources, the project concentrated on architecture design. This implies that:

1. In the demonstrator design, no actual end devices were included. The effort to incorporate such devices to the design is disproportional to the benefit of including them. Instead, a real end device was simulated by deploying a programmable wireless node.
2. The propagation environment, antenna and hardware design issues are beyond the focus of the demonstrator. Disturbances or failures caused by EM interference are not considered.
3. Cyber security attacks are outside the scope of the assignment.

These aspects should be considered and investigated in a follow-up study.

2 Concept exploration and analysis

2.1 Current wired avionics system

Modern aircraft rely on many different systems. Functions like navigation, propulsion, flight control, radio-communications etc., are applications based on and supported by computers and electronic equipment such as displays, sensors, and actuators. These sub-systems need to exchange data to support the applications. The system responsible for interconnecting all sub-systems is the Electrical Interconnection System (EIS).

Currently, EIS is based on wired connections (also called Electrical Wiring Interconnection System or EWIS). The system is built with flight conditions in mind. The transmitted messages should arrive to their destination within a bounded time and with a low failure rate. Redundancy is paramount: critical parts of the network can have up to three alternative routes. Extra care is given for the cables to withstand environmental conditions like EM interference, extreme temperatures and vibrations. Hence shielding, proper material selection and ruggedized construction at connectors are applied to EWIS.

The EIS architecture depends on aircraft size, type and age of manufacture. However, in all cases the EIS architecture adapts to the design architecture of the aircraft electronics (also known as avionics) design.

The most prevalent avionics design paradigm for all kinds of aircraft designed in the last 20 years is the Integrated Modular Avionics (IMA) architecture^[3]. The IMA architecture is intended to support applications of differing criticality levels.¹

The IMA architecture consists of a small number of general-purpose module types that can support multiple applications on the same hardware, interconnected by a highly reliable backbone network (AFDX). The end-devices are connected to these modules. The following elements constitute an IMA system:

- *End devices / Data generators*: Generators of important information that needs to be forwarded to other sub-systems (typically sensors and actuators or local closed loop system controllers). They can be found in any place within the aircraft (engine, wings etc.). A typical 100-seater commuter aircraft is equipped with approximately 100 of such devices. Future aircraft are expected to have significantly more.
- *Data concentrators / Common Remote Data Concentrator (CRDC)*: Modules located in avionics bays close to end devices. CRDCs are data aggregators, responsible for collecting all data forwarded by specific end devices. A typical 100-seater commuter aircraft is equipped with approximately 20 of such devices.
- *Backbone network*: Interconnected Ethernet switches forming 2 redundant Ethernet networks. These switches form the backbone of the EIS network and route packets from data concentrators to their destination (Core Processing I/O Modules or End devices). The backbone network runs through the fuselage of the aircraft. A typical 100-seater commuter aircraft is equipped with approximately 15 of such devices.
- *Core Processing I/O Modules (CPIOM)*: General purpose computers running applications for various aircraft systems simultaneously, through virtualization. CPIOMs are responsible for handling all the aircraft's applications. Information from the end devices is forwarded to CPIOMs to be processed, monitored, displayed to the flight crew, stored or communicated to the ground, etc. They are usually located in an avionics bay near the cockpit. A typical 100-seater commuter aircraft is equipped with approximately 20 of such devices.

¹ For more information, see Appendix E

An example of IMA EIS network architecture is displayed at figure 1.

For the context of this assignment, an IMA architecture is assumed. Most modern aircraft (Airbus A350, A380 and Boeing B787 are notable examples) are IMA compliant. Furthermore, it is expected that the IMA remains a reference architecture for the coming aircrafts generations.. The IMA architecture has considerable benefits, making it likely that it will be the basis for future aircraft.

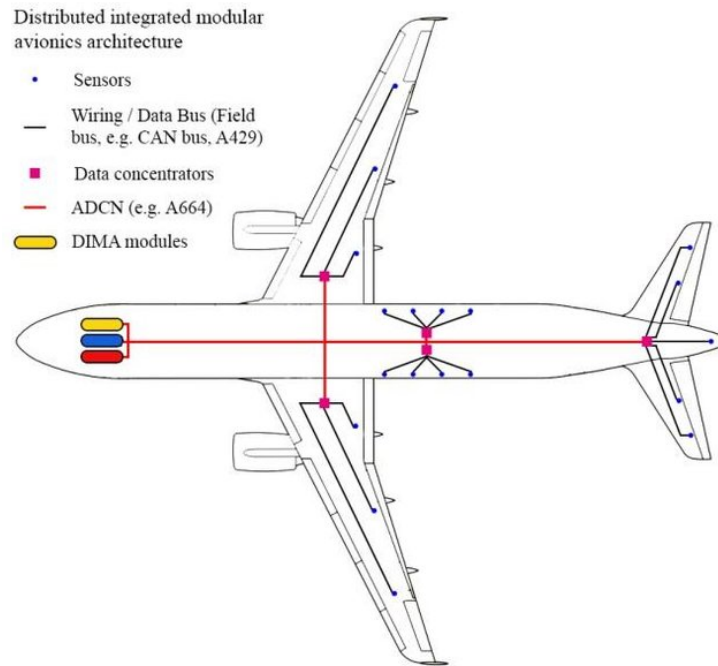

Figure 1: Integrated Modular Avionics (IMA) architecture example.



Figure 2: Simplified IMA functional communication diagram

2.2 Wireless technologies and methods

Wireless technologies provide a wide array of possibilities to design a wireless EIS. The design space of such solutions is overwhelming. The exploration of this design space was the objective of deliverables D1 and D2. (Appendix A and B respectively).

A high-level overview of the most important matters regarding the use of wireless standards for EIS design is presented in the following section.

2.2.1 Operating frequency

An important aspect of any wireless network is the operating frequency. The International Telecommunication Union – Radio sector (ITU-R), global regulator of communications, has licensed the 4.2 – 4.4 GHz band^[4] (also known as the Wireless Avionics Intra Communication / WAIC band) to be used for safety related intra-flight communication. Studies have been performed to understand the properties of this band^[5] for radio communication. It is still unclear if this band is capable of supporting a fully wireless EIS network. Furthermore, the Radio Altimeter (RA) (aircraft equipment used to determine the altitude of an aircraft) is also using the same band. Preliminary analysis shows that this problem can be overcome.^{[6] [7]}

Alternatively, parts of the unlicensed Industrial Scientific and Medical (ISM) band can be used (2.4 – 2.5 GHz). While a network based on the ISM band will make industrialization easier, since the band is extensively studied and many Commercial Off The Shelf (COTS) solutions are operating in the ISM band, this approach has a significant problem. Passenger electronics like tablets, laptops, phones and wireless headphones operate in the ISM band. Hence, an ISM based wireless EIS network will be prone to interference. This topic needs to be studied further to come up with a well-supported technical solution.

2.2.2 Considered Wireless protocols

Many researchers have tried to evaluate the feasibility of using various existing protocols for the foundation of a wireless EIS network^{[23] [8]}. In a report analyzing the spectral characteristics of a wireless EIS network^[9], the ITU-R suggests the use of IEEE 802.11 and IEEE 802.14.5 protocols. Based on the ITU-R analysis, the protocols are used for different types of traffic: high data rate traffic relies on the IEEE 802.11 protocol and low data rate traffic relies on the IEEE 802.14.5 protocol. The conclusion of this report is that the spectral budget is sufficient for a wireless EIS network that fulfils EIS safety requirements (high link reliability, low delays etc.).

However, since the publishing of the report (2013), aircraft operator needs have changed. With the prospect of electrically powered aviation, the number of sensors is growing. Furthermore, more demanding applications (e.g., live camera feed of the wings) are being considered. This implies that the applied protocols are potentially unfit to fulfil future EIS requirements such as increased network size or higher data rates. A trade-off study must be carried on to select the optimal wireless protocol suite.

2.2.3 Wireless Reliability Mechanisms

To address the growing need for reliable and low and bounded latency communications, a wide range of mechanisms have been developed. These mechanisms can be applied to a wireless network regardless of the protocol. Some key mechanisms that can be the foundation of a high reliability and low bounded latency wireless network are presented in this subsection.

- Spatial diversity: Sending and/or receiving the same message through multiple nodes or antennas. This method is helpful to keep the network resilient against hardware failure, hazards (fire etc.), interference and multipath fading.
- Time diversity: Sending the same message at different times. Useful against bursty interference.

- Frequency diversity: Sending and receiving the same message over different frequencies. Useful against frequency selective interference and other propagation effects (multipath fading and shadowing).
- Resource reservation: Sending messages on pre-determined time/frequency slots, to avoid collisions. Useful to offer guarantees in latency and packet reception ratio.
- Dynamic routing: Sending messages through the link with the highest quality signal. Useful to adapt to a shifting propagation environment.

2.3 Identifying the demonstrator design space

To come up with meaningful and precise requirements, the demonstrator design space must be narrowed down. The objective is to use the analysis of the current EIS system design principles and the available wireless technologies to come up with a demonstrator design that is realistic and suits the ambition of Fokker Elmo.

During the exploration phase, many demonstrator concepts were proposed.^[10] The final selection was made based on the following considerations.

- Relevance to the IMA architecture: The IMA architecture is considered a point of reference for current and future EIS network design. This should be reflected in the demonstrator design.
- Realistic project scope. Wireless technology is new and untested from an EIS network design point-of-view. To gain track record
- Novel approach to wireless EIS: For example, a wireless flight entertainment system can already be deployed using COTS parts and therefore it is not interesting within the context of the PDEng assignment.
- Information accessibility: There should be enough publicly available information to properly support the design.

The selected demonstrator concept was based on a smaller scale version of the first part of the IMA communication chain (End device to Data Concentrator link, see Figure 2). This decision maximizes the weight gain of a wireless system as this part replaces the most wired connections.

Furthermore, there are various protocols that avionics developers use to facilitate End Device to Data Concentrator links. The most prominent are ARINC 429^[11] and CAN busses^[12]. The ARINC 429 bus is used more often than the CAN bus. Furthermore, ARINC 429 had important design limitations. ARINC 429's layout mandates that a physical cable is deployed for each ARINC 429 link. This limitation introduces significant cabling overhead and weight. ARINC 429's wide adoption and weight inefficiency means it is a more interesting candidate for a wireless demonstrator.^[13]

In conclusion, the selected demonstrator concept consists of a smaller scale wireless version of an ARINC 429 bus.¹ The demonstrator will replicate the exchange of messages between end devices and data concentrators. This decision checks all the selection criteria: ARINC 429 is relevant to the IMA architecture, provides an interesting test case for wireless based EIS networks, is novel and protocol details are available to the public.

¹ Other avionics communication standards like CAN bus or AFDX are out of scope. The ambition is to design a system that in the future can be upgraded or improved to also facilitate other standards.

3 Requirements

In this section, the requirements applying to the design of the demonstrator will be discussed. Key requirements are presented in Table 1, followed by a rationale section where the reasoning behind the requirements is explained. These requirements are to be used as a reference in the validation phase of development. ^[14]

| Requirement | Description |
|----------------------------|--|
| R1 – ARINC 429 word format | The demonstrator must offer at least one interface for an ARINC 429 input from a system controller (ARINC 429 Gateway). |
| R2 – Latency bound | The demonstrator must transmit data within a delay bound of 30 ms. End-to-end latency < 30 ms |
| R3 – Reliability | The demonstrator must offer reliable communications on par with established aviation standards. Packet reception ratio > 99.99% |
| R4 – Data rate | The demonstrator must at least support the data rate of the ARINC 429 bus specification. Application data rate > 100 kbit/s |
| R5 – Transmission power | The maximum transmission power must respect regulations. Equivalent Isotropically Radiated Power (EIRP) < 50 mW |

Table 1: Key Requirements for the Demonstrator

Most of the demonstrator's requirements are derived from the selected application. Designing for a network that offers end-to-end transparent ARINC 429 service comes with certain implications.

Baseline requirements are derived from the ARINC 429 bus itself. The demonstrator network must at least achieve the same performance as an ARINC 429 data bus would in an EWIS based network. That applies to requirements R1 and R4: ^[15]

- *R1 – ARINC 429 word format:* The ARINC 429 protocol specifies a particular format for all generated messages (called words). To ensure that the demonstrator network can support the transmission of ARINC 429 messages, the demonstrator should be able to both accept ARINC 429 words as input and give ARINC 429 words as output.
- *R4 – Data rate:* The ARINC 429 protocol specifies two different bit rates *high* (100 kbits/s) and *low* (12.5 kbits/s). Achieving the high bit rate of 100 kbit/s means that the demonstrator can support an ARINC 429 link¹.

¹ With respect to the ambitions set in D4, a nice-to-have requirement is an application data rate > 1 Mbit/s

The ARINC 429 specification does not fully describe the expected latency and reliability. Hence, the relevant requirements need to be backed up with additional material.

- *R2 – Latency bound*: This requirement is derived from the requirements of example systems that rely on ARINC 429 and has been confirmed as relevant through communication with avionics specialists working for the NLR.
- *R3 – Reliability*: This reflects the estimated error specification of the ARINC 429 communication bus. Following aviation standards for reliability^[16], an overall network reliability of 10^{-5} is considered acceptable. This means that the minimum per link reliability must be at least 10^{-4} . The equivalent reliability metric is that each generated packet should be received correctly with a probability of 99.99% (reception ratio $\geq 99.99\%$).

Furthermore, when considering a wireless network it is important to take care not to interrupt the safe operation of other devices operating on the same frequency, e.g. the radio altimeters.

- *R5 – Transmission power*: In order to respect regulations and EMC requirements set by the ITU-R, the maximum EIRP is set to 50 mW. At this transmission power, the safe operation of the RA is guaranteed, regardless of antenna placement and fuselage shape.

4 Demonstrator design strategy

4.1 Project management framework

In the original project plan, the work schedule was defined. The project is broken down to four phases:

- 1) The preparation phase: exploration of industry ambitions and roadmaps.
- 2) The definition and analysis phase: demonstration concept definition.
- 3) Demonstrator implementation phase: demonstrator implementation.
- 4) Evaluation and conclusion phase: demonstrator evaluation

This approach is similar to the V-model^[17]. The phases can be understood as Requirement Analysis, Architecture design, Implementation and Validation & Verification.

At the start of the assignment, the V-model approach of the project plan was deemed appropriate. Because there is no previous work similar to the project it was decided to emphasize deepening the knowledge on all relevant topics and investigate all potential alternatives.

A different project management approach was selected for demonstrator development. A wireless based EIS network is relatively novel. The complexity of the design makes it hard to estimate the outcome of the assignment and what is feasible given the project resources. To address the risk of uncertainty in the demonstrator development, an incremental design approach was applied.^[18]

The incremental design approach calls for breaking down the workload to smaller phases called development phases. The first phase is a minimal operating version of the demonstrator. In each following phase, one or two features are added to the demonstrator. Each of those development phases must be completed within a short, predetermined amount of time.

The benefit of this approach is that it is easy to adapt the plan according to the demonstrator development status. If a particular phase takes too long or if it becomes apparent that it cannot be finished in time, then the plan could be adjusted.

4.2 Implementation schedule

To plan the contents of each development phase, relevant topics of complexity were identified. These topics are features that must be implemented to meet the requirements of the demonstrator. The topics that are part of the demonstrator development plan are:

1. **#Senders**: The number of network nodes that generate and transmit packets.
2. **#Sinks**: The number of network nodes that receive the generated packets.
3. **ARINC 429 format**: The payload of the generated packets will adhere to ARINC 429 protocol standards, known as the ARINC 429 word format.
4. **Mock display**: Real-time visualization of received packets.
5. **Packet Sniffer**: Software that captures and logs all incoming demonstrator packets.
6. **Reliability methods**: Wireless mechanisms to increase the demonstrator’s reliability. Discussed further in the following sub-section 4.4.1 “Design for reliability”.

The original phase plan, as conceived at the start of the implementation phase in December 2020 can be found next (table 2).

| Topic | Phase | Basic | ARINC 429 | Sniffer | Add Senders | Redundancy | Toy display |
|-----------------------------|-------|--------|-----------|---------|-------------|------------|-------------|
| | | 1 | 2 | 3 | 4 | 5 | 6 |
| 1 #Senders | | 1 | 1 | 1 | 2 | 4 | 4 |
| 2 #Sinks | | 1 | 1 | 1 | 1 | 2 | 2 |
| 3 ARINC429 format | | No | Mock | Mock | Mock | Mock | Mock |
| 4 Mock display | | No | No | No | No | No | Yes |
| 5 Packet Sniffer | | No | No | Yes | Yes | Yes | Yes |
| 6 Reliability methods | | No | No | No | No | Yes | Yes |
| EXPECTED FINISH TIME | | 18-Jan | 05-Feb | 12-Apr | 30-Apr | 26-May | 18-Jun |

Table 2: Original phase development plan starting at 20-December-2020. The plan is taking to account non project work, leave time and buffer time.

A breakdown of the phases is presented next:¹

1. Phase 1 / Basic: Simple point-to-point network. One node will generate random packets which the Sink node will receive. The demonstrator will not indicate any performance metrics and no mechanism to improve network latency and reliability will be applied.
2. Phase 2 / ARINC 429: Adding ARINC 429 packet generation. The Sender node will generate ARINC 429 words, which will be decoded by the Sink.
3. Phase 3 / Sniffer: Basic packet sniffer implementation. The packet sniffer will record packet end-to-end latency and total packet reception ratio (PRR). The achieved metrics will be used to evaluate the demonstrator.
4. Phase 4 / Add Senders: Adding 3 Senders / ARINC 429 word generator nodes.
5. Phase 5 / Redundancy: Add 1 redundant sink node and implement appropriate reliability mechanisms. (Refer to 4.4.1 “Design for reliability”).
6. Phase 6 / Toy display: Develop a toy application that will display the received packets in real time. The objective was to make the demonstrator more attractive to the stakeholders. Due to time constraints, this phase was not implemented and is not part of the final demonstrator.

¹ Details on the architecture and deployed hardware can be found in later subsections. Details on the actual implementation can be found at the next chapter.

4.3 Deployed Wireless Technologies

The function of the demonstrator is to send ARINC 429 words over a reliable wireless network. ARINC 429 however, is a wired protocol.

To implement wireless transmission of ARINC 429 messages an already established wireless PHY and MAC/Data Link protocol is used. The service data units of the Data Link layer will be ARINC 429 words. Thus, the Wireless ARINC 429 (WARINC 429) demonstrator network should act as an end-to-end ARINC 429 connection.

Selecting a suitable radio technology and the lower layer protocols is an important part of the demonstrator design.^[19] The selection criteria are:

1. How well are the safety requirements satisfied (low, bounded latency and reliability).
2. Is hardware and software available.
3. The availability of mechanisms to handle noise and interference and to offer guarantees at the network level.

Based on these design criteria and work done during the concept exploration phase¹, IEEE 802.15.4e with the Time Slotted Channel Hopping (TSCH) MAC method was selected.

IEEE 802.15.4^[20] is a standard defining the lower two OSI layers: PHY and Data Link. The standard is built specifically for low power, low data rate applications that require reliable communications. It has been used widely, especially for Internet of Things applications. Key features of IEEE 802.15.4 are presented:

- ISM band (2.4 – 2.5 GHz). This band is broken down into 16 channels of 2 MHz bandwidth with a guard band of 5 MHz.
- Supported data rate of 250 kbits/s.
- Offers two different access modes.
 - Contention based, where the nodes compete for access to the network. To avoid collisions the Carrier-Sense Multiple Access with Collision Avoidance method is deployed (CSMA/CA). In this mode, nodes first sense the carrier before transmitting. If the carrier is free, then a node can transmit. In case of collision, a back-off mechanism is implemented. This mode makes efficient use of radio resources and leads to low packet latency. The trade-off is non-deterministic behaviour.
 - Time Division Multiple Access (TDMA) mode, where nodes can reserve a guaranteed time slot. This increases the chance that the packet will be correctly received and makes the network more deterministic to the cost of inefficient use of network resources.

The TSCH channel access mode introduced by the IEEE 802.15.4e^[21] amendment to the protocol was designed to better support the industrial markets. TSCH builds upon 802.15.4 and aims to improve the reliability of the network and make it more robust to interference. To accomplish these goals, the following features are implemented in TSCH:

- Time-slotted access. Communication between network nodes takes place in well-defined time slots that repeat over time. A full sequence of timeslots is called a Slotframe. Time slots are either shared between links or are assigned to a specific transmitter/receiver couple. This feature prevents internal interference in the network and makes it easier to predict available bandwidth.
- Multi-channel communication. Network nodes can communicate at the same time (i.e., same slot) using different channels. This feature increases network capacity.

¹ This is explained in-depth in deliverables D1 and D2. The selection was made between 802.11 variants, Li-Fi technology, 5G technology and TSCH.

- Frequency hopping. Consecutive messages are broadcasted on a different frequency, according to a frequency hop pattern. The effects of interference and multipath fading are mitigated
- Device synchronization. The network must be synchronized for the proper operation of time-slotted access. All network nodes are synchronized based on the coordinator of the network (usually the sink node). Synchronization happens whenever a node receives a packet from the coordinator.

In short, TSCH uses diversity in time and frequency to provide reliability to the upper network layers. Its main applications are wireless sensor networks and industrial wireless communications. TSCH is considered as the go-to solution for low power reliable wireless networks.

The performance metrics that IEEE 802.15.4 networks offer are similar to the design requirements. The supported data rate is 250 kbit/s (satisfying requirement R4), 50 mW of radiating power is enough for normal functionality (R5), while TSCH comes with built-in mechanisms to increase network reliability (R3). TSCH's performance and mitigation mechanisms satisfy criteria 1 and 3.

Furthermore, TSCH has been associated many times with wireless EIS development. An IEEE 802.15.4 based network was suggested by ITU-R and the WAIC consortium^[9], its feasibility for low power wireless EIS networks has been investigated and found sufficient^{[22] [23] [24]}. Additionally, the effective communication range of the IEEE 802.15.4 protocol is approximately 10 meters, which is comparable to the average distance of an ARINC 429 link.¹

Finally, IEEE 802.15.4 / TSCH is very popular. There are many COTS embedded platforms that come with built-in 802.15.4 functionality or can be programmed to function as an IEEE 802.15.4 node. The wide range of supported implementation options means that the second design criterion for the selection of a wireless technology is satisfied.

Consequently, TSCH is suitable for the development of the demonstrator.

However, a drawback of TSCH is that it cannot properly support an industrialized future-proof product. Applications that require significantly more power and/or bandwidth than the demonstrator or that operate in the WAIC band cannot be supported by TSCH. This drawback does not impact the design of the demonstrator so it can be dismissed. Furthermore, the evaluation of the applied architecture and reliability mechanisms of a TSCH based demonstrator will be valuable for any further wireless EIS network development.

4.3.1 Hardware and software

The design of the demonstrator network based on TSCH will be implemented with the help of programmable radio modules.

The demonstrator will be based on the Contiki-NG^[25] operating system. Contiki-NG is an open-source OS that provides multitasking and a built-in Internet Protocol Suite (TCP/IP stack). The network's nodes (WLRUs and RDCIs) will run C code compiled with the libraries provided by Contiki-NG. Furthermore, the Contiki-NG network simulator tool Cooja^[26] will be used for initial testing of the demonstrator.

Contiki-NG is selected due to its accessibility and the available support. The main advantages of Contiki-NG over other embedded network development suites are:

¹ The average length of an ARINC 429 link is 15 meters. This figure is based on Airbus A320.

- Extensive documentation^[27], where all code is collected and explained. Includes read-me files, examples and more.
- Open-source code that can be modified to add relevant reliability mechanisms.
- Strong support over various platforms (Stack Exchange, Gitter and the dedicated wiki).

The zolertia RE-MOTE radio module is the deployed hardware of choice.^[28] RE-MOTE is an 802.15.4 enabled radio platform. Considering other 802.15.4 COTS modules, RE-MOTE is the best performing in terms of processing power, battery life, robustness and connectivity making development easier. The RE-MOTE nodes will be programmed through Contiki-NG. The programming process involves connecting the node to a computer through a USB cable and uploading the applied C program.

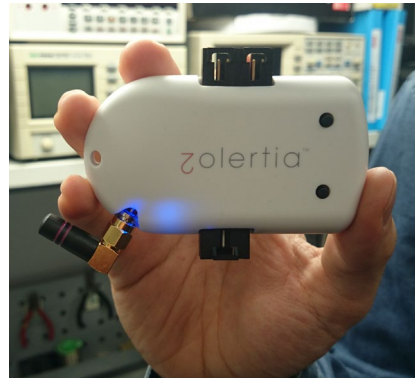

Figure 3: The RE-MOTE module

4.4 Demonstrator architecture

The selected demonstrator concept is a wireless version of ARINC 429 (WARINC 429). Functionally, the demonstrator network must be able to send ARINC 429 words from a source (sensor/actuator or modular units called Line Replacement Units LRUs) to a concentrator (CRDC).

Actual ARINC 429 word generators, like sensors and LRUs are not part of the demonstrator. Instead, the ARINC 429 word is generated inside the sender nodes of the demonstrator network. These sender nodes are called Wireless Line Replacement Units or WLRUs. WLRUs function is to generate ARINC 429 words and send them to a network sink.

Network sinks are called Remote Data Concentrator Interfaces or RDCIs. RDCI's function is to receive ARINC 429 messages from WLRUs, extract the ARINC 429 word and forward all received packets to the Server / Packet Sniffer. The Server captures these packets, counts dropped packets and calculates basic network metrics (PRR and packet latency).

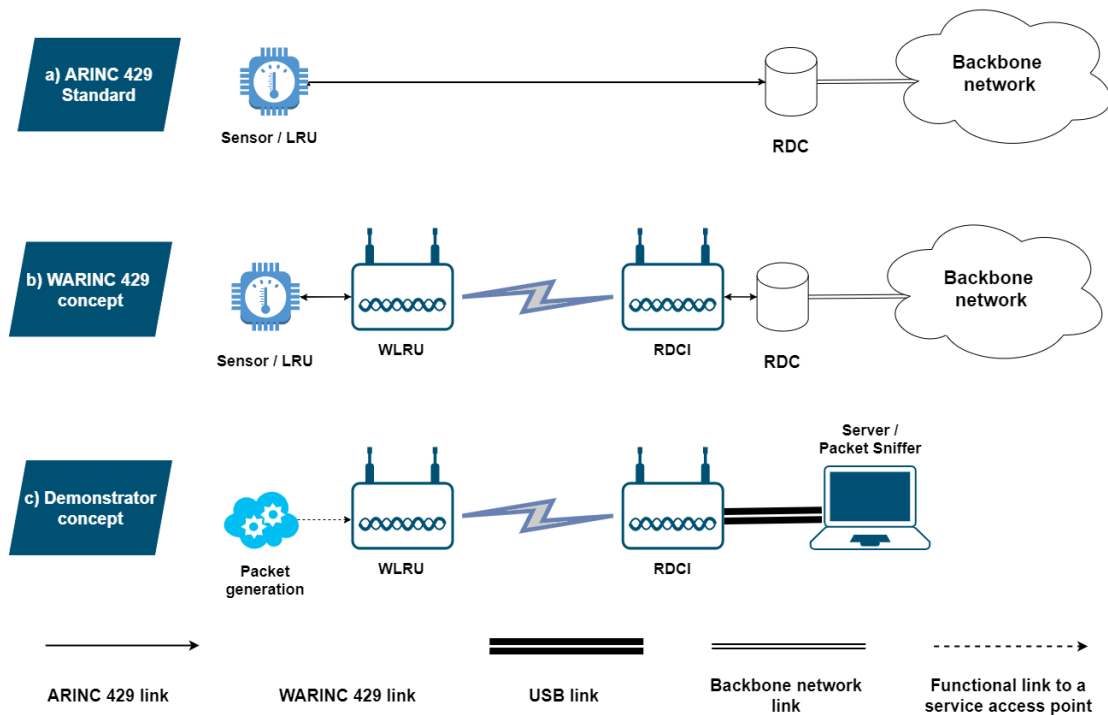

Figure 4: Demonstrator functional architecture. From top to bottom
 a) An example of an ARINC 429 link, according to the current IMA EWIS architecture.
 b) The proposed WARINC 429 concept in the context of the broader IMA architecture.
 c) The proposed demonstrator architecture

To understand the function of the demonstrator, the figure 4 shows three different perspectives of the demonstrator’s functionality.

4.4.1 Design for reliability

A significant risk in the design of the demonstrator is not meeting the safety requirements. Latency (R2) and reliability (R3) are the most important safety related requirements. A common way to reduce latency is to wait for confirmation messages and hence not use retransmission in case a message is lost. The consequence of this approach is less reliable transmission. Conversely, reliability is increased when all sorts of confirmation mechanism and redundant transmissions are implemented. Thus, reliability and latency are often a trade-off in wireless network design.

To address the risk of not fulfilling both safety related requirements, several technical solutions have been proposed. Three of these methods were identified in the concept exploration phase.

One of these methods will be part of the design phase of design phase 5. Given the limited project resources, a selection was made based on a trade-off analysis. The demonstrator’s development status, method feasibility and the method’s function will be the inputs for the trade-off analysis.¹

¹ This is further explained at section 5.3

The selected methods are:

1. **Redundant networks:** Drawing inspiration from current EWIS design, redundancy can be introduced to the wireless demonstrator network. Current EWIS design guidelines suggest redundancy where applicable. It is common practice to duplicate (if not triplicate or quadruplicate) critical links or systems. A similar approach can be applied to the wireless demonstrator.

There are multiple ways redundancy can be introduced to a wireless network. In the context of the demonstrator design, redundancy of hardware (transmitters and receivers) is considered. Double wiring can be functionally equivalent to sending the same packet from two different transmitters to two different receivers. An example network based on the hardware redundancy approach can be seen at figure 5. This approach will increase the total PRR and latency and protects against other kind of hazards (hardware failure etc.).

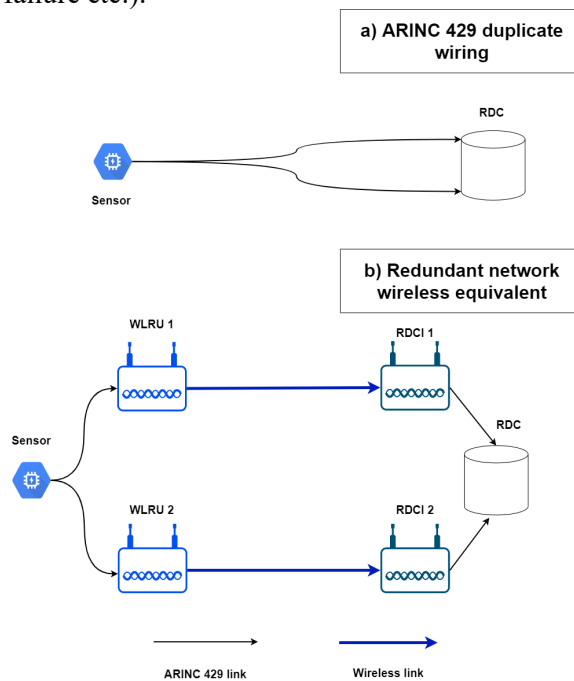

Figure 5: a) ARINC 429 duplicate wiring b) Redundant network wireless equivalent

2. **Routing diversity:** To provide guarantees for packet reception in reliable wireless networks, cooperative packet relaying has been considered. [29] Cooperative relaying is a routing diversity solution. In the context of the demonstrator design, cooperative relaying refers to sending high criticality packets from a WLRU two times: one directly to an RDCI and one second time through a neighbouring WLRU that will then forward the packet to an RDCI.

This method can increase overall PRR without sacrificing latency since no re-transmission will be required. The benefits of routing diversity to increase PRR are worth the implementation costs if the radio environment is noisy and interference is expected. An example network based on the routing diversity approach can be seen at figure 6.

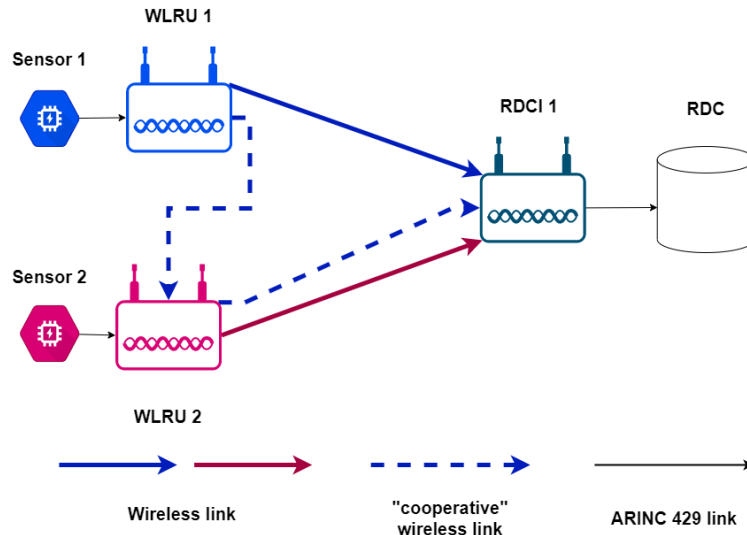

Figure 6: Routing diversity wireless example. Note that WLRU 2 is not only a relay node, but also transmits its own packets.

3. **Contention-free Medium Access Control (MAC):** Instead of relying on contention for channel access which can make the network's performance hard to predict, the MAC layer can be designed to offer guarantees. This is typically achieved by using a contention-free Medium Access Control.

One implementation of contention-free MAC is scheduling. A network based on scheduling assigns network resources (time slots and frequency slots) to each link according to a schedule. The schedule can either be fixed or dynamic. This approach can make the network more predictable, which will help limit the maximum latency. An example implementation of wireless scheduling can be found in figure 7.

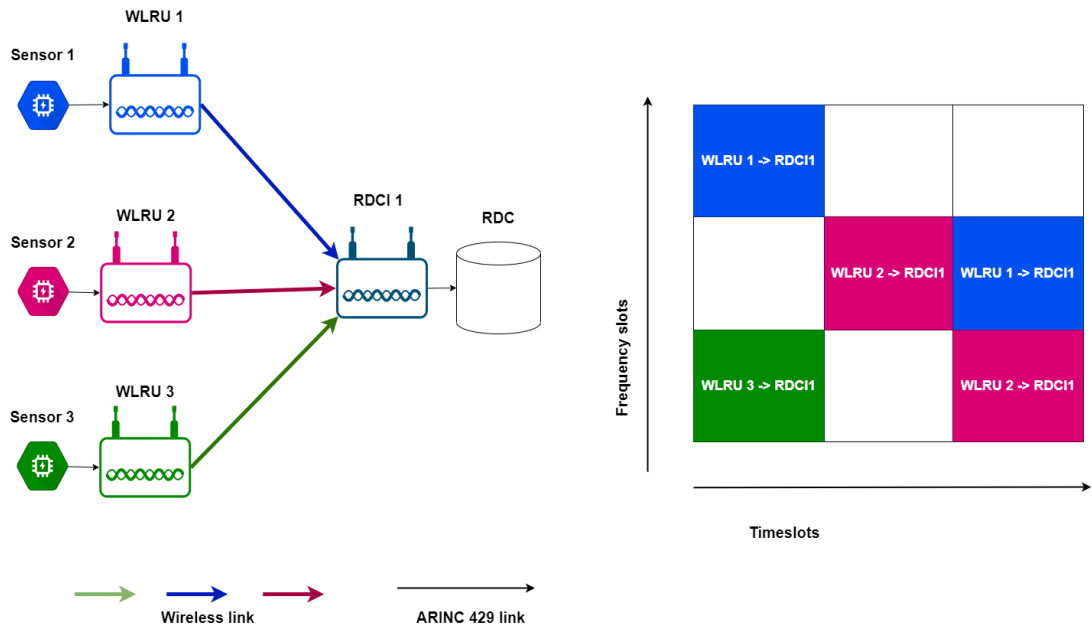

Figure 7: Example wireless network based on scheduling

4.4.2 Reliability mechanisms Trade-off analysis

The most promising reliability mechanism was selected for development. To select the method that was going to be developed at phase 5, a trade-off analysis was performed. The reliability methods were evaluated based on the following criteria:

- a) Development value: Some methods have been deployed extensively in wireless networks. Their effect on network performance is known and well-studied. Applying for such a method and tuning it optimally for the demonstrator is more suited for a fully industrialized product. Instead, a method that is unique and its effect to network reliability is difficult to estimate is more valuable to the stakeholders.
- b) Demonstrator requirements: The demonstrator at phase 4 might not meet all requirements. Methods that can improve the demonstrator's performance (especially regarding the safety requirements) to fulfil or surpass the requirements are preferred.
- c) Implementation feasibility: The estimated development time and the method's applicability to deployed protocols and software.

To come up with a decision on which reliability mechanism was to be implemented, each reliability mechanism was evaluated based on the identified criteria.

1. Redundant networks

- a. Development value: A redundant approach to wireless network design is relatively novel. In the design of wireless networks, traditionally cost-effectiveness is an important design requirement and thus non-redundant solutions are preferred (applies to sensor networks, entertainment systems and to a lesser extent radio and tv coverage). Considering EIS design, safety requirements are more extremely important. Consequently, the redundant network method would add value to the design of the demonstrator.
- b. Demonstrator requirements: A parallel redundant network has the potential to increase overall network reliability since it protects against hardware failure, localized interference and errors due to multipath propagation. With regard to latency, this approach is not expected to show improvements.
- c. Implementation feasibility: According to the demonstrator design, the WLRU acts as a message generator and a transmitter. As such, to implement this approach care must be given to properly duplicate the message generation mechanism.

2. Routing diversity

- a. Development value: Existing literature covers similar development ideas.^[29] However, this topic is relatively new, and its effect has not been tested thoroughly. Consequently, the routing diversity method would add value to the design of the demonstrator.
- b. Demonstrator requirements: Offering two routes can increase the chance of packet reception but does not improve latency.
- c. Implementation feasibility: To offer alternative routes, the WLRU functionality must be altered. The WLRUs should be capable of receiving and forwarding other WLRU packets instead of only generating and transmitting their own. This addition complicates the design considerably.

3. Contention-free MAC

- a. **Development value:** The MAC functionalities offered by TSCH can be exploited to design a robust scheduler that can add determinism to the network. While this approach would improve the demonstrator’s performance in terms of maximum latency, Contention-free MAC protocols have been discussed extensively in literature. As such, tuning a contention-free MAC scheme would be more suitable for a higher TRL project.
- b. **Demonstrator requirements:** Time guarantees for packet delivery decrease the worst-case latency and increase PRR. A contention-free MAC mechanism can be deployed to help meet demonstrator requirements.
- c. **Feasibility:** Designing and optimizing a contention-free version of the TSCH MAC mechanism is a complicated process and would take significant amount of the remaining project time.

The results of this analysis are visualized in the following table:

| | Redundant networks | Routing diversity | Contention-free MAC |
|----------------------------------|---------------------------|--------------------------|----------------------------|
| Development value | + | + | - |
| Demonstrator requirements | - | + | + |
| Feasibility | + | - | - |

Table 3 : Reliability mechanism trade-off matrix

Based on the analysis, a trade-off decision was taken in favour of the redundant network approach.¹ This method adds significant value to the stakeholder portfolio, since it is novel and addresses key safety aspects of EIS design.

¹ All stakeholders were involved in the decision-making process.

5 Demonstrator implementation

This chapter contains a detailed description of the demonstrator's development. This is accomplished by describing how the planned phases were implemented. This definition includes a breakdown of the deployed code and systems.

5.1 Phase 1 – Point-to-Point communication

The first step of the demonstrator design is to build a network with minimal functionality.

This is accomplished by a point-to-point IEEE 802.15.4 network. This network consists of one WLRU node and one RDCI node. The WLRU generates a packet every 10 seconds.¹ The payload of the packet is a randomly generated series of 32 bits, representing an ARINC 429 word. The RDCI receives the packet and acts as the TSCH coordinator node. A functional diagram of the demonstrator after completion of phase 1 can be seen at figure 8.

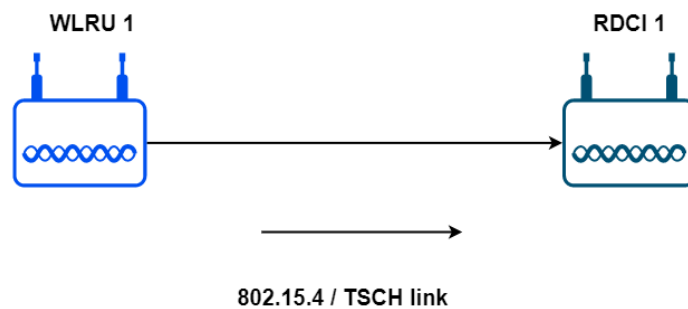

Figure 8: Phase 1 demonstrator implementation functional diagram

The deployed TSCH version is based on the 6TiSCH minimal configuration as is implemented in Contiki-NG.^[30] This configuration includes a static schedule and a security architecture (authentication and encryption features). According to the minimal schedule, all nodes communicate on a single shared timeslot (duration 10 ms), within a single slotframe which repeats endlessly. Nodes compete for access to the medium. This MAC scheme is comparable to slotted ALOHA^[31].

The frequency hop sequence that is applied is 20, 15, 25, 26. These channels were selected because they were not overlapping with frequencies commonly used by IEEE 802.11.

5.2 Phase 2 – ARINC 429 word generation

Following the architecture, the WLRUs must generate valid ARINC 429 words. The code that the WLRUs run has been updated to accomplish ARINC 429 word generation. The following flowchart illustrates the function of the ARINC 429 word generator.

¹ The frequency of packet generation was set to 10 seconds for easier monitoring of the test simulations at real-time.

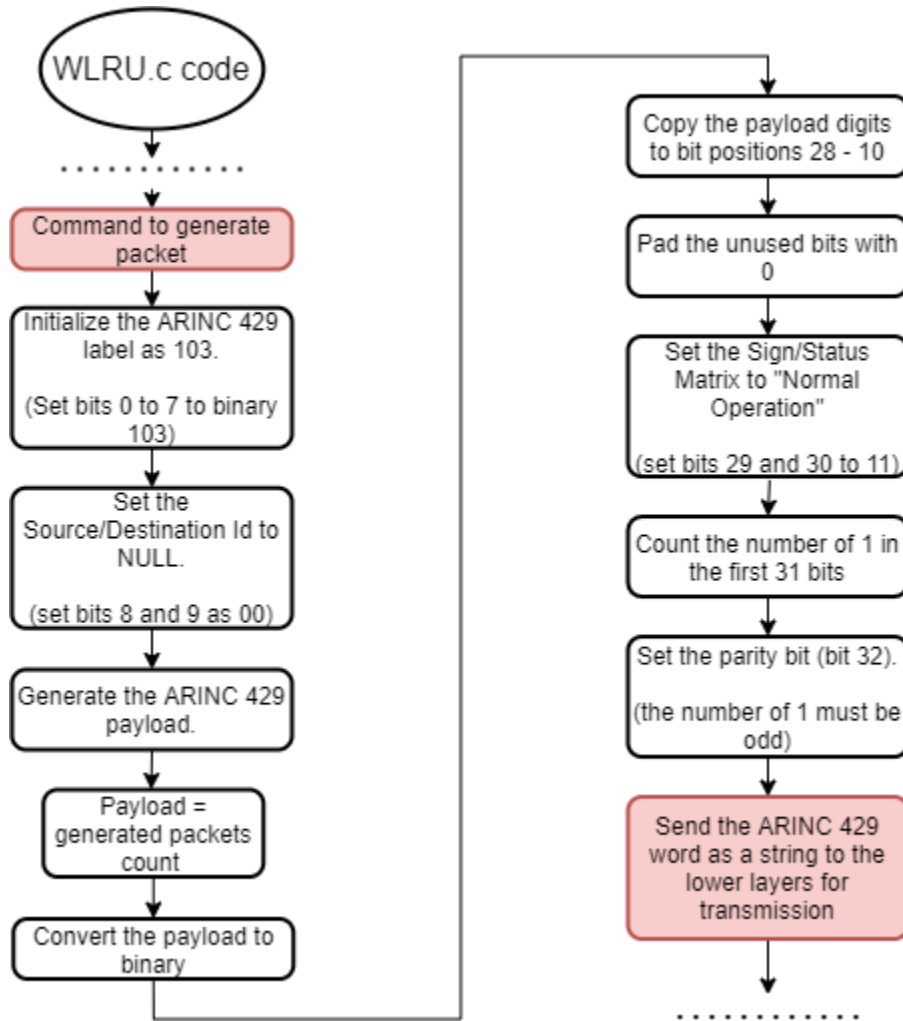

Figure 9: ARINC 429 phase 2 software flowchart.

This process generates a pseudo-random series of 32 bits that conform to the ARINC 429 word protocol and can thus be called an ARINC 429 word.¹ The payload bits of the generated ARINC 429 words are used to send the count of the generated messages.² The count is going to be used to calculate the packet reception ratio at the next phase (phase 3, Packet Sniffer).

After the ARINC 429 word is generated, it is forwarded to the lower layers of the demonstrator network. The lower layers are implemented based on the IPv6 over Low Power Wireless Personal Area Networks (6LoWPAN) framework.^[32] 6LoWPAN is a low overhead, low complexity full-stack implementation of IEEE 802.15.4 that fits 802.15.4 frames to IPv6 packets through an adaptation layer.

The ARINC 429 word is encapsulated within UDP datagrams and exchanged over the demonstrator network. The UDP datagrams are contained within an IPv6 packet. The IPv6 packet is delivered through the IEEE 802.15.4e / TSCH protocol. The OSI layer representation of the described procedure and the functional diagram of phase 2 are presented on the following figures.

¹ Some of the flags of the ARINC 429 word are set to constant values. This applies to Source/Destination (used to identify the sender) and Normal Operation bits (used for basic network diagnostics), since lower layers of the WARINC 429 demonstrator network perform these functions

² The label bits (used to identify the type of transmitted payload) are set to 103 (airspeed in knots / second).

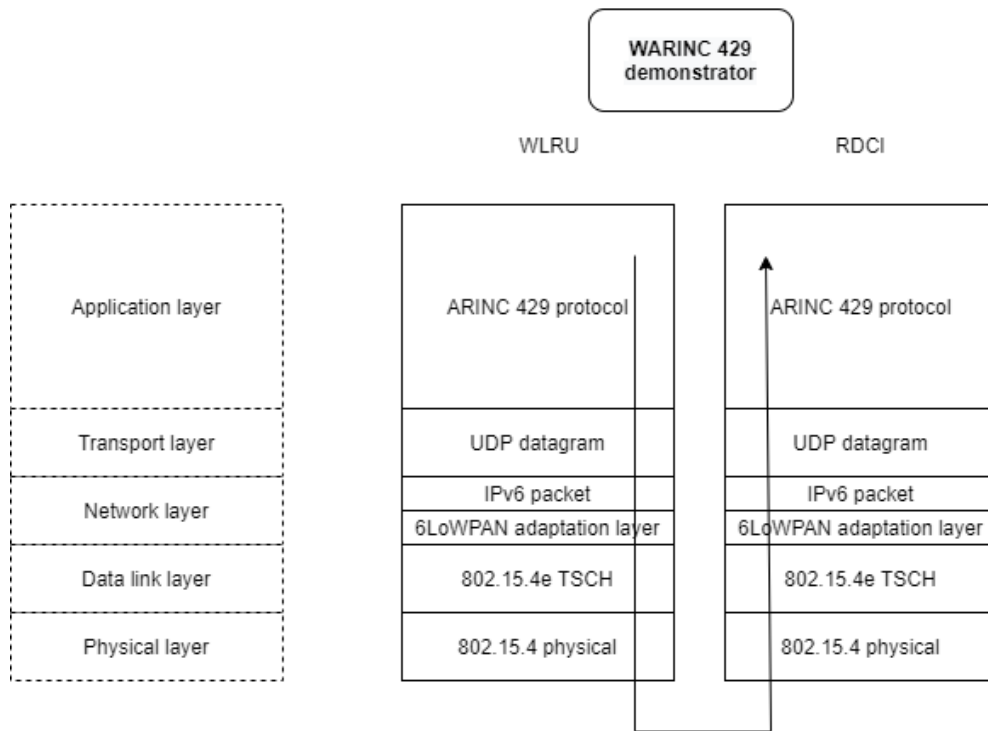

Figure 10: OSI diagram, WLRU to RDCI communication at UC 2 level.

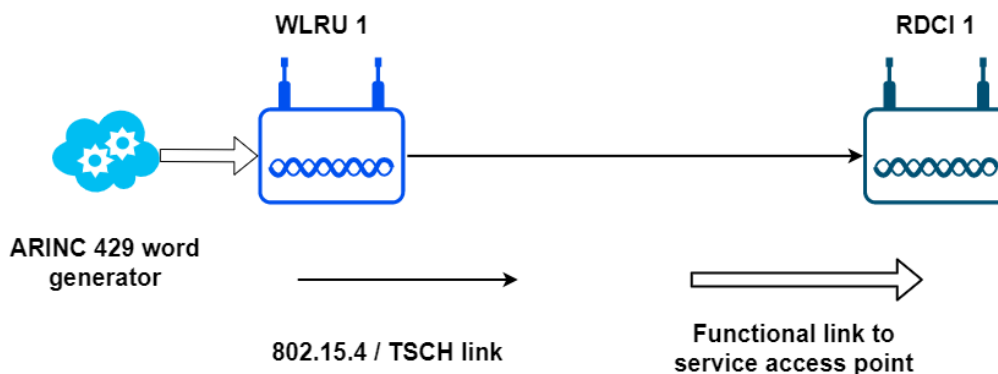

Figure 11: Phase 2 demonstrator implementation functional diagram.

5.3 Phase 3 – Packet sniffer

The development goal of phase 3 is to implement a mechanism that can keep track of basic network metrics (latency, PRR). These metrics will be used to evaluate the performance of the demonstrator based on the selected requirements. A packet sniffer (a computer program that intercepts and logs incoming traffic) is going to be designed to capture incoming WARINC 429 packets. The captured packets will then be used as input to a post-processing algorithm that will print out the end-to-end latency per packet and the total network PRR.

The packet sniffer code runs on a separate computer (packet sniffer or server). The computer is connected with a USB cable to the RDCI. The RDCI forwards all packets received from the WLRU to the packet sniffer. The packet sniffer then captures the forwarded packets and parses the ARINC 429 word. The payload of the ARINC 429 word, which is the number of the generated packets, is printed out. By comparing the number of the generated packets to the received packets, the PRR can be calculated. This communication chain is presented at the OSI layer diagram presented at figure 12 and the functional diagram at figure 13.

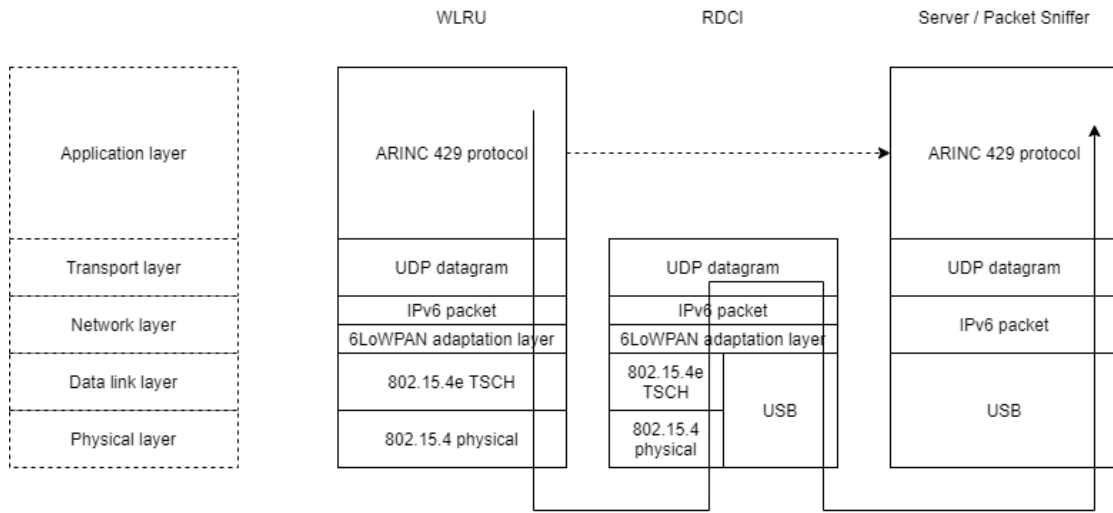

Figure 12: OSI diagram, Packet Sniffer communication

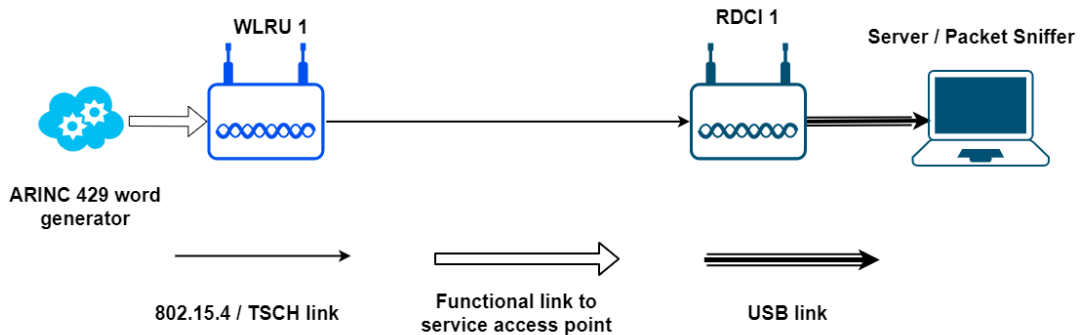

Figure 13: Phase 3 demonstrator implementation functional diagram.

This implementation enables tracking the network’s PRR. Additionally, phase 3 calls for measuring the network’s maximum observed latency.

In particular, the objective of phase 3 is to calculate the maximum end-to-end latency. This refers to the total time (measured in ms) it takes since the ARINC 429 word is generated up until the corresponding WARINC 429 packet is received at the RDCI. This time reflects the total delay the WARINC 429 network adds to the broader EIS communication chain.

Tracking end-to-end latency is complicated. A universal time reference is necessary to be able to compare the time of packet generation with the time of packet arrival to the upper layers.

To accomplish this, the implementation takes advantage of the inherent synchronization of TSCH networks. All network nodes of a TSCH network synchronize their clock time to the time of the IEEE 802.15.4 coordinator node. In the case of the demonstrator network, the RDCI acts as the coordinator node. To synchronize, whenever a node gets a message from the coordinator it checks the coordinators clock time (included in the message) and updates its internal time to match the coordinator. In between messages, the nodes de-synchronize due to clock drift. The clock error due to drift is calculated^[33] to be 20 μs/s. Since at least one TSCH frame is generated per 10 s, the drift error (20 μs/s * 10 s = 0.2 ms) can be considered insignificant compared to the latency requirement of 30 ms.

Assuming node synchronization, the implemented solution relies on timestamps. The WLRU code was extended further: when an ARINC 429 word is generated, the WLRU calculates its current clock time¹. The WLRU combines the ARINC 429 word with the calculated time in a single string and forwards the message to the lower layers.

A similar process takes place in the RDCI. Upon receiving a message, the RDCI checks if the message is a WARINC 429 packet. In this case, the RDCI calculates its own time and prints it out to the console before forwarding the packet to the packet sniffer. This process is illustrated at the next flowchart at figure 14.

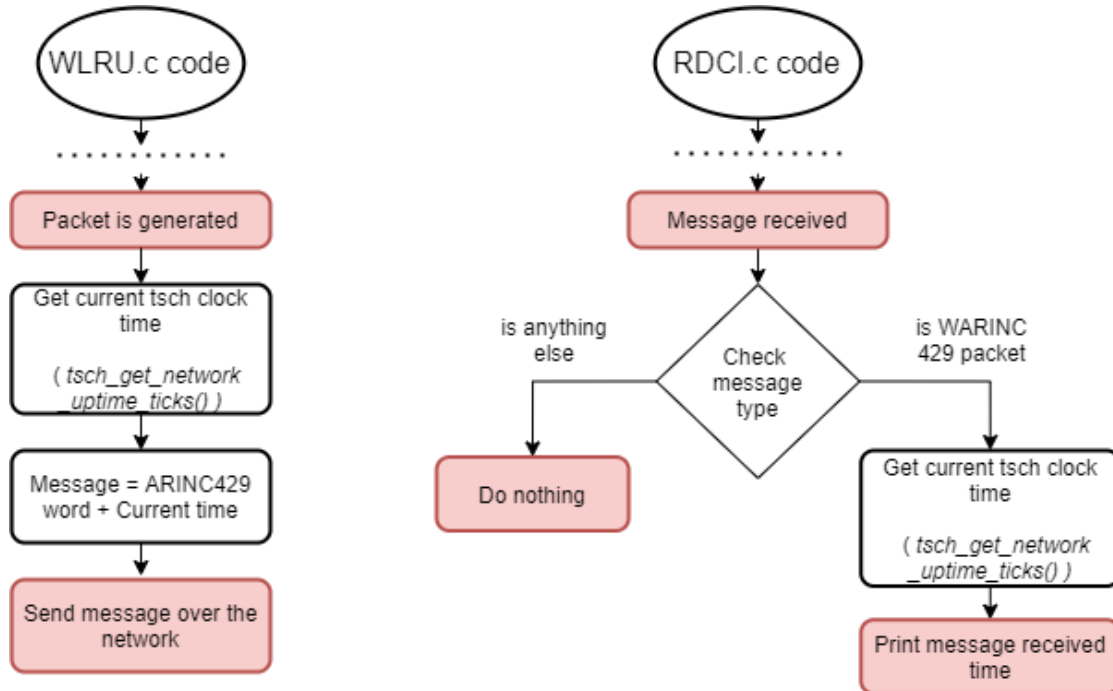

Figure 14: ARINC 429 phase 3 software process

The end-to-end latency in clock ticks is the difference of RDCI clock time and the WLRU clock time (end-to-end latency_{ticks} = RDCI_{time} – WLRU_{time}). The clock ticks to second ratio is 256. The conversion to ms is based on the following formula (end-to-end latency_{ms} = 1000 * end-to-end latency_{ticks} / 256). This calculation is carried out by a MATLAB post-processing script that uses the RDCI’s printouts and the packet sniffer output as input.

Because this calculation takes into account clock ticks, the resulting latency values are quantized. Latency values are always multiples of 3.91 ms (1000 * 1/256). Consequently, the error of the latency metrics of this implementation is +/- 1.95 ms.

5.4 Phase 4 – Increased network size

According to the development phase plan, the next implementation task is to increase the network size. Three more WLRUs must be added to the network. This addition helps to make the demonstrator more believable and closer in scale to a real ARINC 429 bus. A functional diagram of the demonstrator of phase 4, is presented at figure 15.

¹ The current clock time is calculated by the Contiki-ng function `tsch_get_network_uptime_ticks()` that returns how many clock ticks have elapsed since the network’s creation. This time is synchronized on the coordinator node.

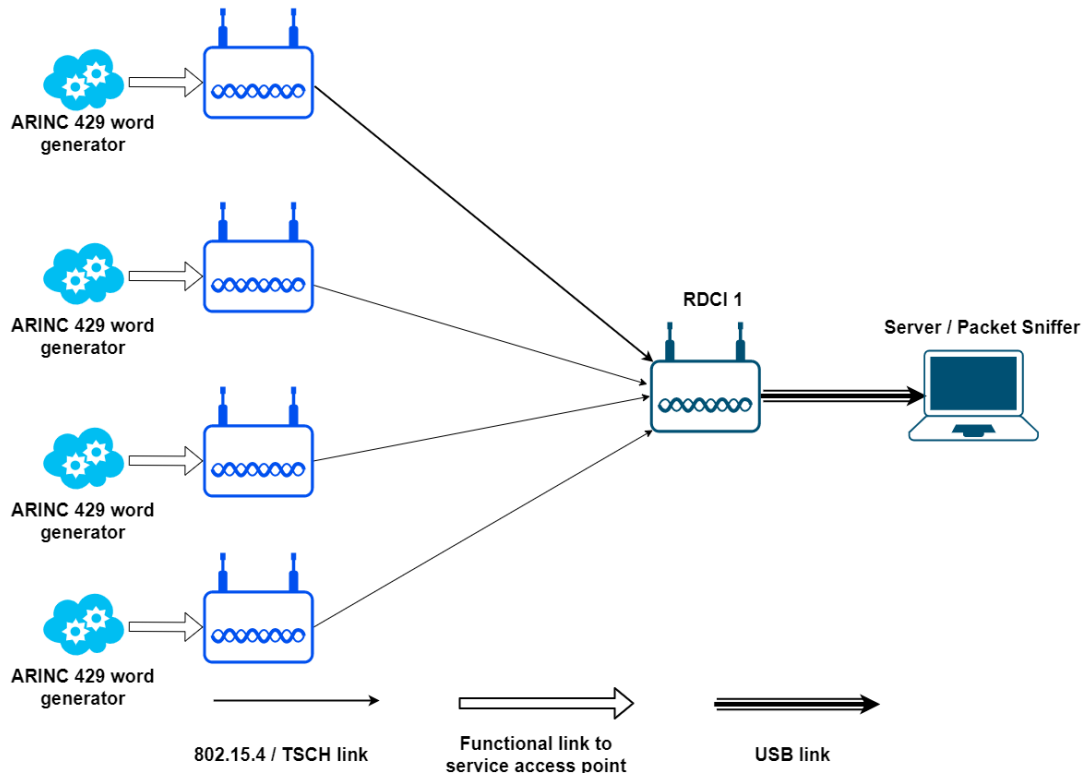

Figure 15: Phase 4 demonstrator implementation functional diagram.

5.5 Phase 5 - Applied reliability mechanism

Based on the trade-off decision described in sub-section 4.4.2, the objective of phase 5 is to implement the redundant network approach. The premise of the redundancy approach is that the basic architecture remains the same but gets duplicated. Two important design considerations were taken into account to successfully implement this design:

- ARINC 429 word duplication.** In a real EWIS network, the same message can be sent over two (or more) different links by adding an extra wire. In the case of the demonstrator, the ARINC 429 messages are generated inside the WLRU. Adding one more WLRU also adds a new message source while the intention is to send the same ARINC 429 word over two different wireless links.

To address this issue, the ARINC 429 word generation approach of phase 2 was expanded. Each WLRU represents a sensor that generates ARINC 429 words. To replicate the duplication of the generated ARINC 429 words, two different WLRUs (WLRU-1 and WLRU-2) are deployed to generate the same sequence of ARINC 429 words. The second WLRU is identical to the first in terms of software and hardware. This addition effectively duplicates the ARINC 429 word and adds redundancy in transmitter hardware and software.

According to the method described at 4.4.1, the receiver hardware must also be duplicated. To address this, a new RDCI is introduced to the demonstrator network. WLRUs that generate the same ARINC 429 word sequence send their packets to different RDCIs. WLRU-1 sends packets to RDCI-1 and WLRU-2 sends packets to

RDCI-2. The two links belong to different 802.15.4e networks.¹ Both RDCIs converge to the packet sniffer, that is the final destination of all received packets.

The 4 deployed WLRUs were arranged to generate two different ARINC 429 payload sequences: two WLRUs generate payload sequence A and two WLRUs payload sequence B. These sequences represent two different ARINC 429 sensors (e.g., airspeed sensor A and airspeed sensor B). The payload sequence of WLRU-A is the count of the generated packets, as implemented in phase2. To differentiate, the payload sequence of WLRU-B was changed to a negative count of generated packets (-1, -2, -3, ...). This method attempts to emulate two different redundant ARINC 429 sources.

The total network is thus a combination of two different networks. Each sub network has two WLRUs (one WLRU generating the payload sequence A and one WLRU generating the payload sequence B) that transmit their packets to a common RDCI. The two RDCIs forward all received packet to the packet sniffer as per phase 3.

- **Duplicate packet handling.** A mechanism needs to be implemented on the packet sniffer side to handle duplicate packets. The packet sniffer code must be able to check for duplicates and drop redundant packets (basic server functionality).

To facilitate this function, the code of the packet sniffer was amended. When a new packet is received, the packet sniffer searches its log files for duplicates (messages with the same payload). If it finds any, it drops the packet and prints out a message.

A functional diagram comparing the implementation of phase 5 to the original wired ARINC 429 bus and a theoretical implementation of redundancy in a future wireless based EIS network is presented at figure 16.

¹ To avoid interference between the sub-networks, the hopping sequence and node id of the secondary network was changed. The hopping sequence of the redundant nodes (e.g., WLRU-2) was set to 25, 20, 16, 18. This sequence takes advantage of the channels not affected by IEEE 802.11 while being differing from the original sequence to avoid intra-interference.

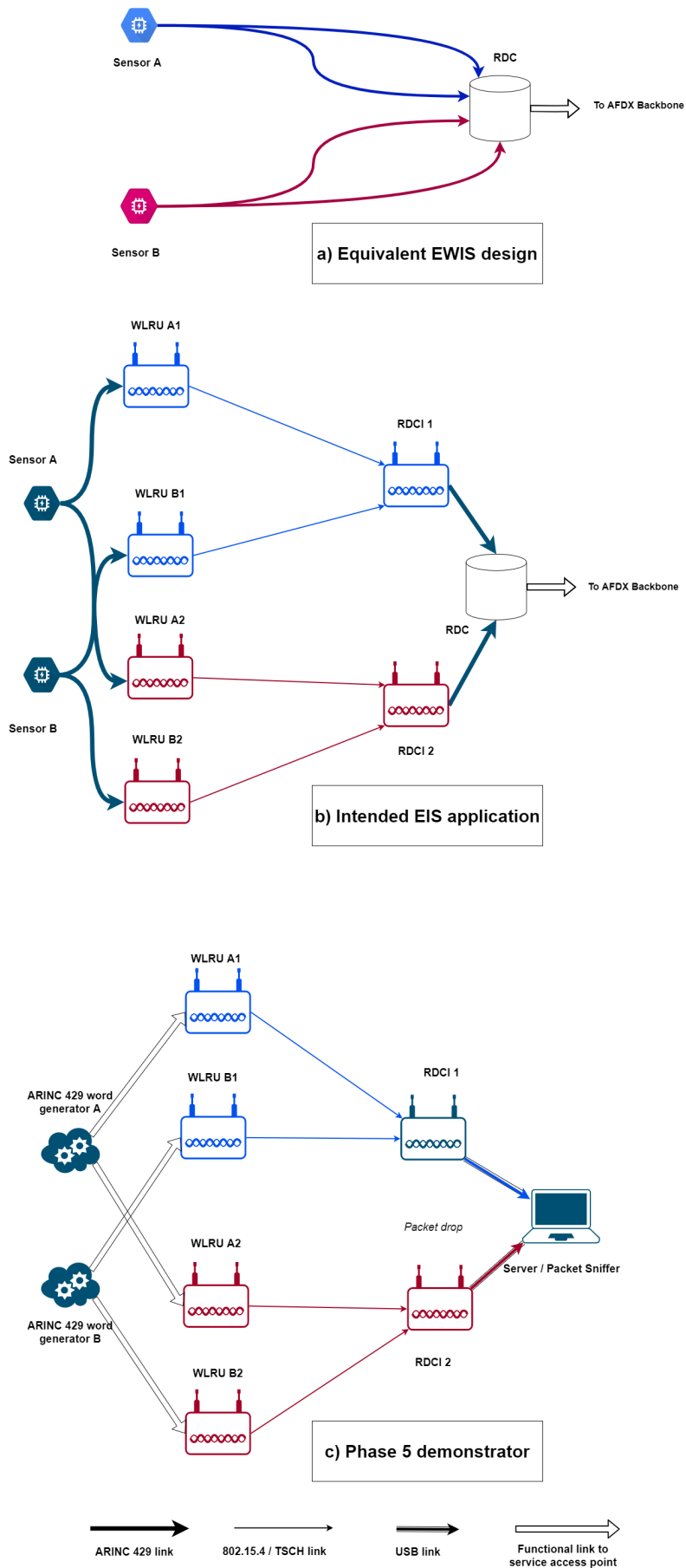

Figure 16: Parallel architecture views of the demonstrator network of UC 5. From top to bottom: a) Equivalent EWIS design b) Intended EIS design application c) Demonstrator implementation of phase 5

6 Demonstrator evaluation

The final part of the demonstrator design process is the verification and validation phase.

The primary objective of the verification process is to provide assurance that the demonstrator functions as intended and meets the specified requirements. The effect of the applied tools and methods to network performance is going to be evaluated. To present a complete evaluation of all considered methods, an estimation of the impact of the methods that were not applied is presented along with suggested improvements to the demonstrator design.

The objective of the validation process is to assess how well does the demonstrator meet the expectations of the stakeholders. To this direction, the demonstrator network will be compared with its EWIS equivalent solution, ARINC 429 in terms of functionality, performance and total weight. Furthermore, a retrospective analysis of the specified requirements compared to the project goals is included.

6.1 Test setup and results

To obtain data on the performance of the demonstrator network and the applied methods, a series of tests were planned. The purpose of the tests is to obtain network metrics (PRR and latency) of the demonstrator network in three different scenarios:

1. Baseline scenario. A demonstrator network without redundancy, similar to the implementation status of phase 3. The network includes the packet sniffer, one RDCI and two WLRUs (one WLRU-A and one WLRU-B).
2. Baseline scenario with packet loss. The same as Baseline scenario, but with the introduction of packet loss. In this scenario, packet loss is modelled by modifying the server code (the server drops 5% of all received packets).
3. Redundancy scenario. The demonstrator network will function as described in section 5.5. In this scenario, packet loss is modelled by modifying the server code (the server drops 5% of packets received from the first network and 5% from the redundant network). The network includes the packet sniffer, two RDCIs and four WLRUs (two WLRU-As and two WLRU-Bs)

The planned duration for each of these tests is two hours. After this time, the network is stopped and the log files are fed to the post-processing algorithm. Given that an ARINC 429 word (and consequently a WARINC 429 packet) is generated every 10 seconds, this means that during the course of one experiment 720 packets are generated per WLRU. The total exchanged data packets are 1440 packets for the Baseline scenarios and 2880 for the Redundancy scenario.

The environment for all the tests is an indoor space in a private residence. All network nodes are placed relatively close to each other (~ 10 cm) and far away from all other electronic equipment (laptops, cellphones etc.). These conditions (some radio noise, but not directed to network nodes) is faithful to the application domain and makes the test more realistic.

In figure 17, a functional diagram of the applied test topology is presented. Figures 18 and 19 are pictures of the test setups.

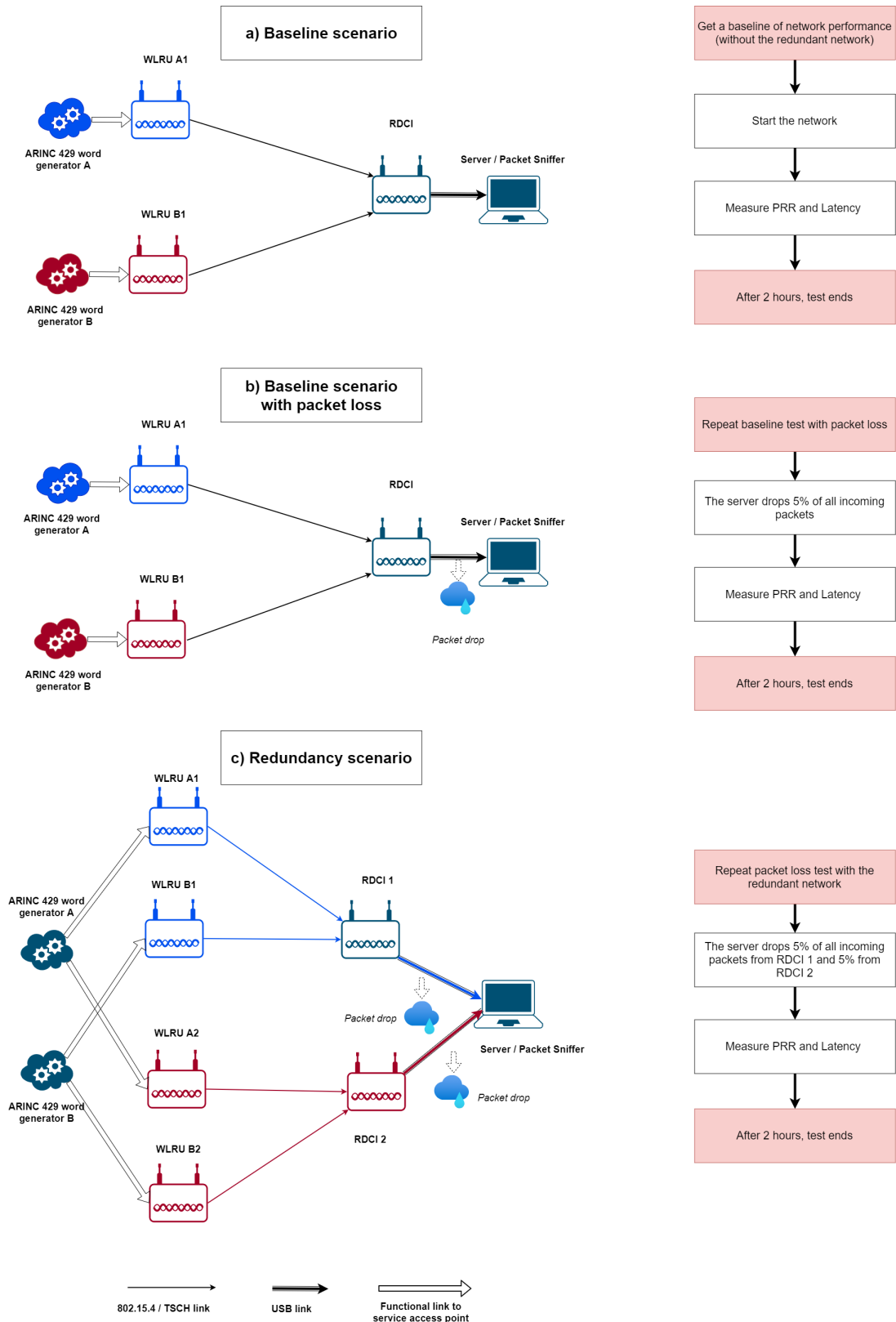

Figure 17: Applied test topology and test procedure. From top to bottom
 a) Baseline scenario topology and test procedure.
 b) Baseline scenario with packet loss topology and test procedure.
 c) Redundancy scenario topology and test procedure.

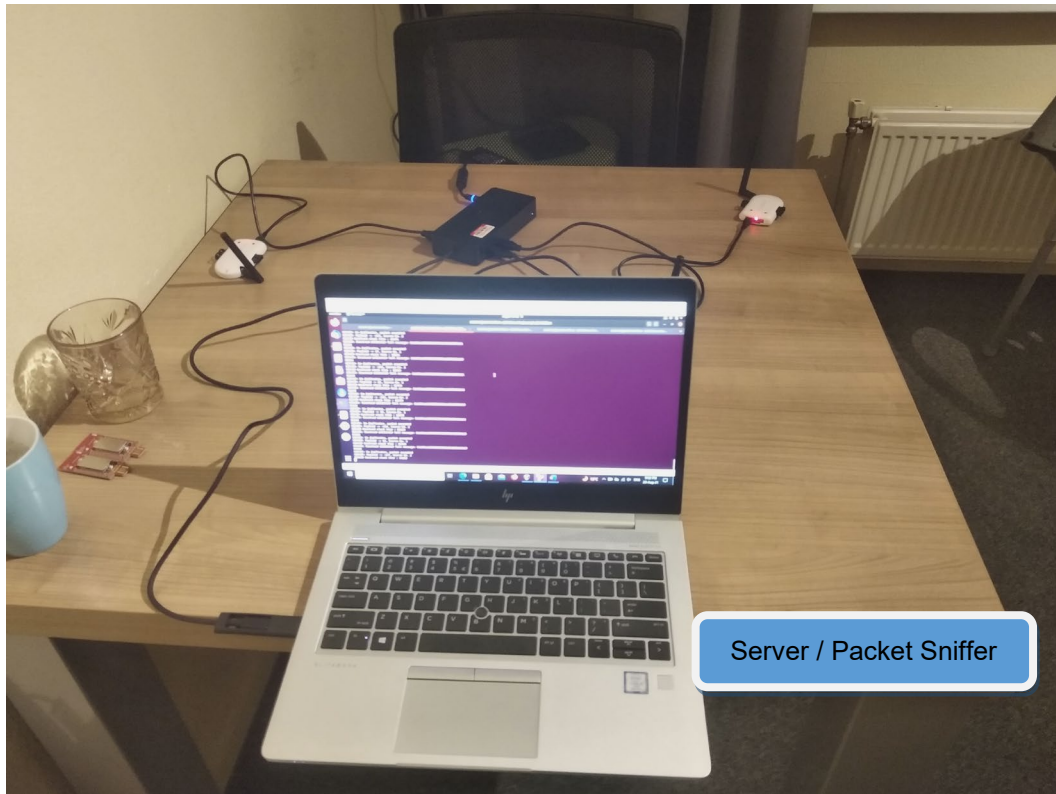

Figure 18: Layout for the tests.

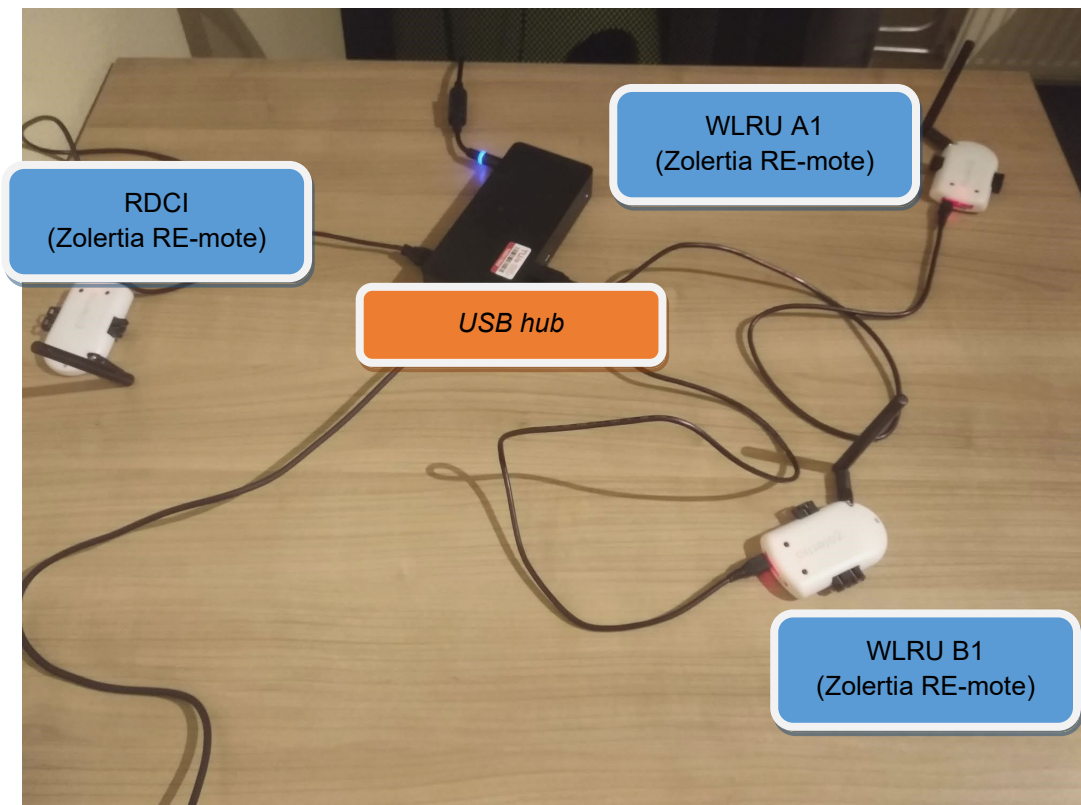

Figure 19: Layout for the tests. The usb hub is used to upload the C code the network nodes and to provide a USB connection between the Server and the RDCI.

The purpose of the baseline test is to study the network’s performance without extra packet loss or the redundant network approach. The baseline test with packet loss was selected to observe the change in the performance of the demonstrator given external packet loss.

Last, the objective of the redundancy test was to investigate the change in the demonstrator’s performance when the redundancy method is applied in a lossy network. Unfortunately, it was not possible to carry out this experiment in time.

The expected result of the test was a significant increase in PRR in comparison to the second test, without impacting any latency metric. Without the test, the effect of the redundant network approach to system reliability cannot be quantified.

The test results of the Baseline test and the packet loss test are presented in table 4 and figure 20.

| | Baseline | With packet loss |
|--|-----------------|-------------------------|
| PRR | 100% | 96.61% |
| Average Latency (ms) | 28.22 | 28.75 |
| Max Latency (ms) | 89.84 | 97.66 |
| Variance Latency (ms) | 25.17 | 35.06 |
| Std Latency (ms) | 5.02 | 5.92 |
| Packets with latency < 30 ms | 81.75% | 76.75% |
| Total unique packets | 1420 | 1420 |

Table 4 : Test results. (The first 20 packets were omitted to avoid the inconsistency of network formation)

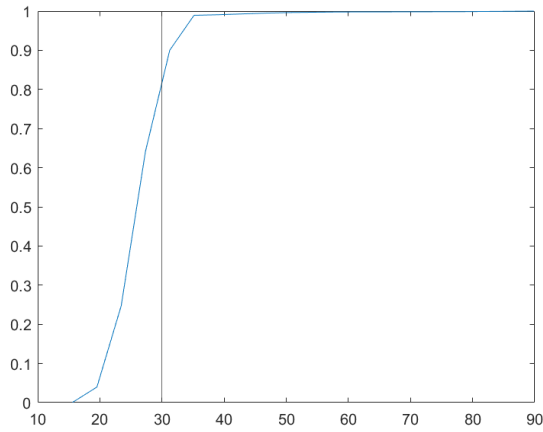

Cumulative Distribution Function (CDF) plot of the latency for the Baseline test. The vertical line represents the maximum latency requirement (latency < 30 ms).

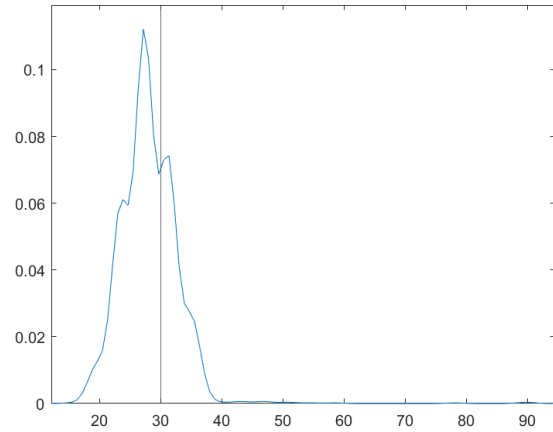

Probability Density Function (PDF) plot of the latency for the Baseline test. The vertical line represents the maximum latency requirement (latency < 30 ms).

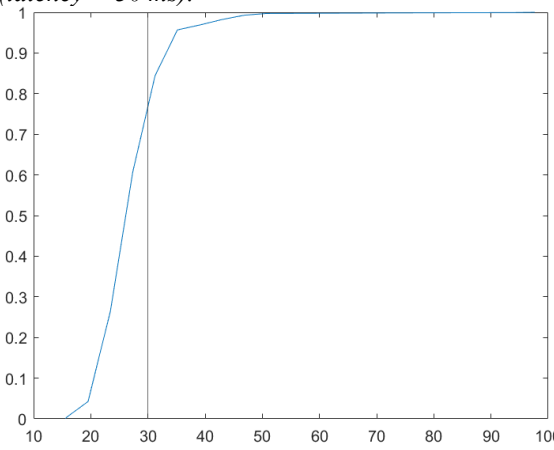

CDF plot of the latency for the Baseline drop test. The vertical line represents the maximum latency requirement (latency < 30).

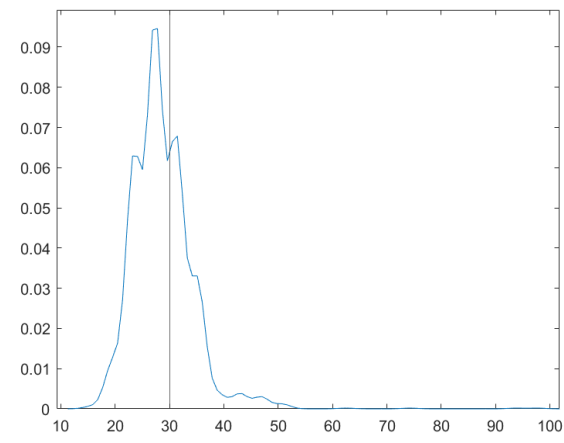

PDF plot of the latency for the Baseline drop test. The vertical line represents the maximum latency requirement (latency < 30).

Figure 20: Demonstrator test results

The different test scenarios appear to impact PRR. In the baseline scenario, the achieved PRR was found to be 100%. When random packet loss was introduced to the network, the total PRR was decreased to 96.6%. Applying for the redundancy scenario resulted in an increase of +3.1% or an achieved PRR of 99.7%. This improvement is achieved due to the redundant approach. In the case that a packet was randomly dropped by the server, the duplicated packet from the respective redundant WLRU was correctly received in its place.

Conversely, the demonstrator network's latency appears to not be affected by the deployed scenario. Average latency ([28, 29] ms) and maximum latency ([80, 100] ms) are relatively consistent among all tests. The distribution of the latency is generally within the boundary of the requirement (< 30 ms) with rare but with extreme exceptions.

The discrepancy between the average latency and the extreme latency values can be attributed to the minimal schedule. Since each sub-network consists of two nodes competing for access, the level of contention is low and most of the time the nodes will communicate effectively (no delays). However, contention-based schemes are not deterministic. If one collision happens, the nodes will have to wait until a back-off timer expires and then try transmitting again. There are no guarantees that a collision will not be repeated on the second attempt. In theory, this loop can go infinitely. In the case of the demonstrator, the observed limit is ~ 90 ms.

Furthermore, the PDF of packet latency is similar among test scenarios. Peaks can be observed around the latency values of 12, 16, 20, 24, 27, 31 and 34 ms. This consistency is influenced by how latency is calculated. Latency values calculated by the packet sniffer are all multiples of 3.91 ms. This seems to apply to the measured latency times.

6.2 Demonstrator verification

The test results and system output can be used to draw conclusions on how well the demonstrator performs with regard to the specified requirements. Overall, the demonstrator performance and the test results align with the design expectations. Under standard conditions (noisy environment, no strong interference) and without the redundant network, the demonstrator satisfies all requirements with the exception of the maximum latency.

The satisfaction of each requirement is presented in detail next.

1. R1 – ARINC 429 Format. The demonstrator supports the ARINC 429 word format. ARINC 429 words are generated at WLRUs and successfully received and parsed at the server. The validity of the ARINC 429 words has been cross-referenced with examples from various ARINC 429 manuals and white papers. **R1 is satisfied.**
2. R2 – Latency bound. The demonstrator fails to meet latency requirements. While the average values are consistently within the requirement for maximum latency (mean Latency ~ 28.5 ms) the maximum value (+ 80 ms) exceeds the requirement. These extreme values are rare as is shown by the CDF plots (less than 20% of the received packets are above the requirement and only 1% of which is higher than 35 ms). **R2 is not satisfied.**
3. R3 - Reliability. The demonstrator network can offer a highly reliable link for ARINC 429 word exchange. Even in a relatively noisy environment with EM interference in the same band, the demonstrator achieves 100% PRR. This is achieved due to TSCH's frequency hopping mechanism. More tests are necessary to confirm this performance. Furthermore, the demonstrator can offer increased reliability even in a

lossy environment due to the redundant network approach. The redundant network not only increased PRR when introducing packet loss (from 96.6% to 99.7%) but also offers spatial diversity and can thus protect against physical hazards or failure of half the network. **R3 is satisfied.**

4. R4 – Data rate. The effective data rate of any IEEE 802.15.4 network is 127 kbits/s. This is suitable for any ARINC 429 networks. **R4 is satisfied.**
5. R5 – Transmission Power. The transmission power of the Zolertia RE-mote node is at maximum 5 mw EIRP.³⁴ This is within the required limit. **R5 is satisfied.**

Failure to meet requirement R2 indicates that designing for bounded latency is an integral part of successful wireless EIS design. Based on the trade-off decision¹ the redundancy method was implemented instead of a method that had the potential to limit worst-case latency. The upside of the redundancy method is that it can increase the network's reliability without worsening latency at the cost of taking up double network resources (hardware, channel etc.). The price that one pays, is that you need to use as many extra resources as replications.

As wireless EIS design matures, appropriate methods to limit worst-case latency must be implemented. As identified earlier, a contention-free MAC method is a promising solution. Taking advantage of the deployed protocols (TSCH), the network nodes can communicate with each other according to a schedule. The schedule will allocate radio resources (frequency and time) to each link. This method has the potential to improve the demonstrator's extreme latency cases. Assuming the cause of the extreme latency values is collisions, since contention is longer necessary, the expectation is that the extreme latency cases will be eliminated. The design price of this approach is that the average latency may increase. This can happen due to inefficient use of network resources (e.g., a WLRU with a packet to transmit must wait until its assigned slot even if there is no other traffic in the network).

6.3 Demonstrator validation

In this section, the validation procedure is explained. Validation refers to the process of ensuring that the demonstrator conforms with the Stakeholder's ambitions and evaluate its design in the context of wireless EIS architecture.

The baseline of the demonstrator is the well-established avionics data bus protocol, ARINC 429. The demonstrator is a wireless version of the ARINC 429 bus. The selection was made because of the protocol's popularity and extensive use by avionics designers and installers. To properly assess the function of the demonstrator, the demonstrator was compared with its equivalent ARINC 429 wired network. The comparison will be made in terms of functionality, performance and total weight.

Regarding functionality, the two networks are almost identical. With slight modifications to the hardware so that the WLRUs can receive ARINC 429 words as input, both networks can transmit the same kind of messages. A solution similar to the demonstrator can virtually replace an ARINC 429 link in future EIS design.

However, the WARINC 429 demonstrator has some design advantages to the original ARINC 429 wired implementation. First, ARINC 429 only supports one-way communications. Conversely, the demonstrator can support two-way communication. Given the architecture

¹ Details in 4.4.2

discussed in earlier sections (figure 1), this functionality allows for the design of more complex systems (e.g., a LRU or an actuator sending requests for data over the network etc.).

Moreover, the flexibility of wireless networks in EIS design should not be underestimated. Apart from weight loss, a wireless network takes less space and does not rely on connectors and bundles which are often source of failure. Changes in the design and over-the-air software updates are also easier compared to a conventional ARINC 429 bus.

Regarding performance, the protocols applied in the demonstrator can offer similar (or better) Quality of Service (QoS) to ARINC with latency as an exception.¹ Including the proposed methods to the design would help decrease worst-case latency. This improvement while significant, on its own likely will not be enough to build a wireless network that can meet the strict requirements of critical systems. In conclusion, with some improvements the demonstrator network would be capable of performing similar to ARINC 429 but in its current form could not match its extremely low latency guarantees when applied to ultra-reliable systems.

Regarding weight, the demonstrator network has an advantage. To calculate the weight savings, the architecture of phase 5 (figure 21) will be used as a reference point. The average distance of ARINC 429 link is assumed to be 15 meters.² ARINC 429 cables are assumed to be twisted pair AWG 24.³

Considering a network with 4 WLRUs and 2 RDCIs, the demonstrator's total weight is calculated as such:

$$\text{TotalWeightDemo15meters} = 6 * \text{Zolertia RE-moteWeight} = 6 * 10 \text{ g} \sim 60 \text{ g}$$

$$\text{TotalWeightARINC15meters} = 2 * \text{Distance} * \text{AWG 24 Weight/m} = 2 * 15 \text{ m} * 13.9 \text{ g / m} \sim 415 \text{ g}$$

This calculation implies significant savings. However, it is difficult to come up with meaningful numbers for the weight of the wireless system at this stage. Actual weight will likely depend on applied architecture, miniaturization and industrialization level. These uncertainties make a direct comparison less believable.

Instead, the minimum distance that a wireless network can replace a wired ARINC 429 connection with significant saving can be calculated.

$$\text{TotalWeightSavings(Distance)} = \frac{\text{TotalWeightARINC}}{\text{TotalWeightDemo}} = \frac{(2 * \text{Distance} * 13.9 \text{ g/m})}{(6 * 10 \text{ g})} = 0.4633 * \text{Distance}$$

Based on these calculations, a wireless network will start to be more efficient in terms of weight when the distance is at least 2.19 m. Internal Fokker expectations account for a potential 30% decrease in total system weight. This decrease is achieved at distances 3 m and beyond. Comparing this distance to the average ARINC 429 link which is 15 meters, it is likely that a wireless network can be more weight-efficient compared to a wired ARINC 429 link.

¹ This does not consider physical layer phenomena such as fading or interference or security attacks (jamming).

² This figure is based on Airbus A320.

³ <https://www.edmo.com/product/D620224/cable-70-ohm-24-awg-for-use-in-arinc-429-data-bus-systems-d620224>
https://www.te.com/commerce/DocumentDelivery/DDEController?Action=showdoc&DocId=Catalog+Section%7F1654025_Sec9_SPE_C55%7F0313%7Fpdf%7FEnglish%7FENG_CS_1654025_Sec9_SPEC55_0313.pdf%7F160136-001

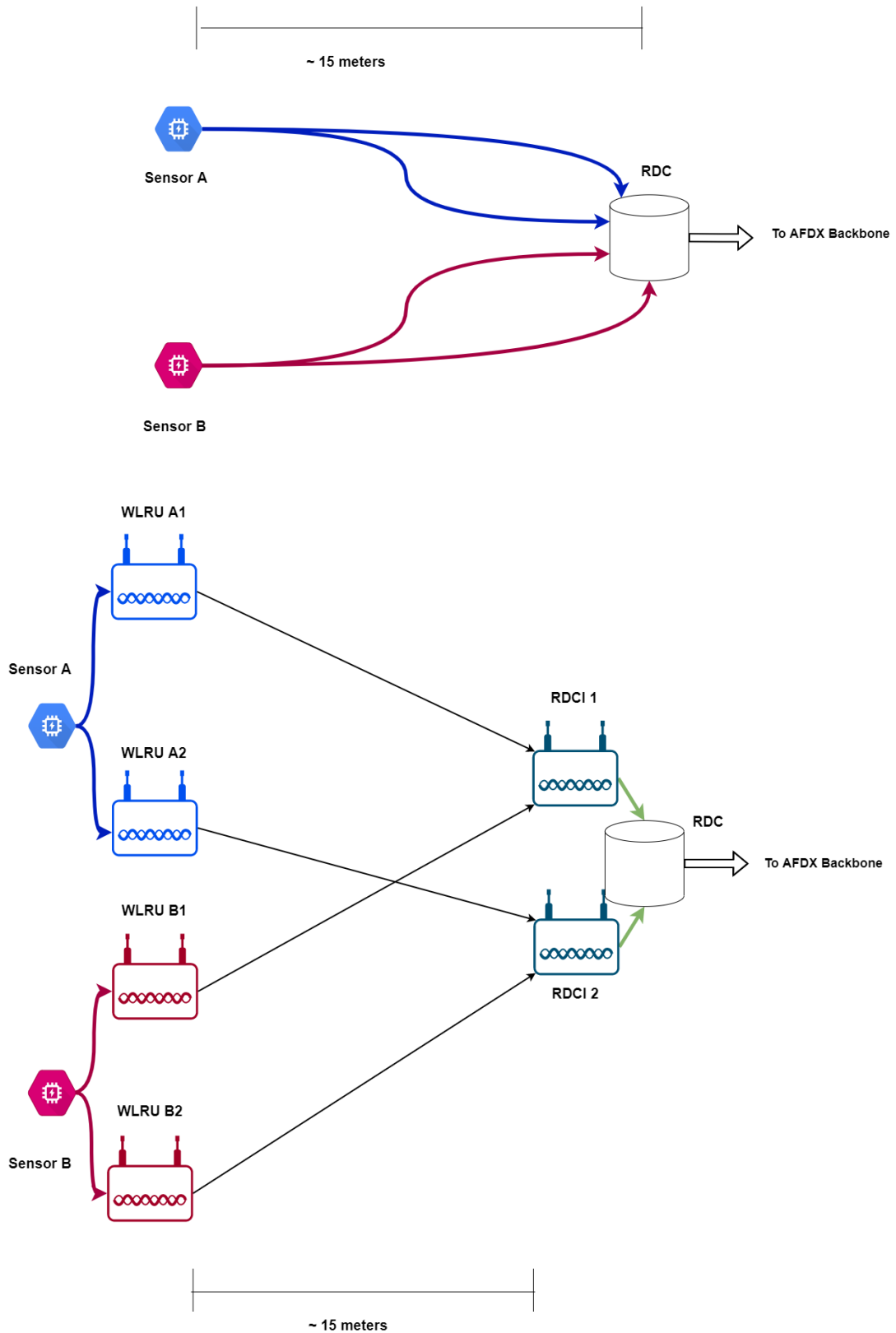

Figure 21: Reference for weight calculations.

Summing up, the demonstrator is aligned with Stakeholder ambitions. The proof-of-concept demonstrator is useful to determine the pros and cons of the wireless approach and the design trade-offs that influence the EIS architecture.

Finally, to fully validate the design, the requirements of the demonstrator network must be evaluated. The requirements were based on the ARINC 429 data bus requirements. As such, all requirements derived from ARINC 429's requirements are important. However, these requirements are not complete on their own.

In particular, the demonstrator's requirements do not clearly define the expected EM environment. This is crucial to a wireless network and should have been clearly stated on the requirements.

Furthermore, the requirement for reliability R3 was not expanded fully. This is evident when discussing the results of implementing phase 5 – the redundant network approach. Reliability should not only count for PRR but also for resilience to failure and hazards and cyber-attacks. While these topics were out of scope for the assignment, solutions that addressed these issues (like phase 5) were especially interesting to the stakeholders. As such, the requirements should better reflect stakeholder ambitions for the broader EIS system.

This concludes the validation of the demonstrator design and the specified requirements. The demonstrator fulfils its objective of exploring the design space of wireless EIS networks.

7 Conclusions and recommendations

Having finished the PDEng project, it is possible to evaluate the decisions taken and translate this experience to future insight and recommendations.

With regards to demonstrator development, the conclusions are:

- The applied architecture and wireless standard **can fulfil the requirements** of the ARINC 429 communication bus with the **exception of bounded latency**. This can be improved by applying the identified reliability mechanisms (especially a contention-free MAC).
- A **system level understanding** of the overall complexity of wireless networks is achieved in support of Fokker Elmo strategy development. This includes identifying the causes of unreliability in wireless networks and methods to mitigate them.

Furthermore, for future work on the demonstrator the following topics should be prioritized:

- **Further testing.** More tests are necessary to complete the demonstrator's verification. Real ARINC 429 components, RDCs and sensors can also be included in the tests to observe the demonstrator's performance when working with actual avionics.
- **Implementation of other reliability methods**, especially contention-free MAC method / scheduler. Time spent designing and implementing a static scheduler will likely result in a better performing demonstrator. The demonstrator can also be further expanded by implementing routing diversity, dynamic scheduling and packet duplication at the physical layer.
- **Complete application implementation.** Adding a real-time display or a real avionics component (sensor or LRU) that generates ARINC 429 words, would make the demonstrator more realistic.

Apart from design experience, demonstrator development helped identify the solution space of wireless EIS networks. Key insights for Wireless EIS network design are:

- **The role of standardization.** While ARINC 429 is deployed widely in current avionics, it is not an optimal solution for the basis of a wireless system. To facilitate design and integration, it's crucial to determine the appropriate standards in terms of applied protocols, technologies and architectures.
- **Future wireless technologies.** IEEE 802.15.4. TSCH is efficient and lightweight but it comes with limitations to the operating frequency and effective data rate. The role of future and existing wireless technologies like 5G, IEEE 802.11 variants, surface waves and wireless optical communication should be investigated.
- **Wireless EIS operating frequency band.** The operating frequency band is an integral part of wireless network design. If the WAIC frequency band is adopted, then more tests need to be carried out to determine the WAIC EM environment inside the aircraft. The design or commission of radio equipment to facilitate WAIC transmissions should also be considered.

8 References

- ¹ P. Park, P. Di Marco, J. Nah and C. Fischione, "Wireless Avionics Intracommunications: A Survey of Benefits, Challenges, and Solutions," in IEEE Internet of Things Journal, vol. 8, no. 10, pp. 7745-7767, 15 May 2021, doi: 10.1109/JIOT.2020.3038848.
- ² Internal Fokker report
- ³ R. Wolfig and M. Jakovljevic, "Distributed IMA and DO-297: Architectural, communication and certification attributes," 2008 IEEE/AIAA 27th Digital Avionics Systems Conference, 2008, pp. 1.E.4-1-1.E.4-10, doi: 10.1109/DASC.2008.4702769.
- ⁴ Recommendation ITU-R M.2085-0 (09/2015) Technical conditions for the use of wireless avionics intra-communication systems operating in the aeronautical mobile (R) service in the frequency band 4 200-4 400 MHz
- ⁵ H. Saghir, C. Nerguizian, J. J. Laurin and F. Moupfouma, "In-Cabin Wideband Channel Characterization for WAIC Systems," in IEEE Transactions on Aerospace and Electronic Systems, vol. 50, no. 1, pp. 516-529, January 2014, doi: 10.1109/TAES.2013.120089.
- ⁶ Coexistence with RA internal report
- ⁷ L. Hanschke, L. Krüger, T. Meyerhoff, C. Renner and A. Timm-Giel, "Radio altimeter interference mitigation in wireless avionics intra-communication networks," 2017 15th International Symposium on Modeling and Optimization in Mobile, Ad Hoc, and Wireless Networks (WiOpt), 2017, pp. 1-8, doi: 10.23919/WIOPT.2017.7959893.
- ⁸ Bang I, Nam H, Chang W, Kim T, Woo JM, Kim CY, Ban TW, Park P, Jung BC. Channel Measurement and Feasibility Test for Wireless Avionics Intra-Communications. Sensors (Basel). 2019 Mar 14;19(6):1294. doi: 10.3390/s19061294. PMID: 30875828; PMCID: PMC6471762.
- ⁹ Report ITU-R M.2283-0 (12/2013) Technical characteristics and spectrum requirements of Wireless Avionics Intra-Communications systems to support their safe operation
- ¹⁰ See deliverable D5
- ¹¹ https://mitindia.edu/images/pdf/avionics_ppt/ARINC_429.pdf Madras Institute Of Technology presentation on ARINC 429
- ¹² https://www.ti.com/lit/an/sloa101b/sloa101b.pdf?ts=1629933606436&ref_url=https%253A%252F%252Fwww.google.com%252F, ti introduction to CAN bus
- ¹³ This information was also confirmed via contact with the NLR. The NLR expects that ARINC 429 will continue being deployed in aircraft for at least the next 20 years and is more relevant than CAN bus.
- ¹⁴ Further elaboration on the rationale for each requirement can be found in the appendix (D, E and F)
- ¹⁵ <https://docplayer.gr/139114969-White-paper-arinc-protocol-tutorial.html> ARINC 429 Protocol Tutorial White paper by abaco systems
- ¹⁶ <https://en.wikipedia.org/wiki/DO-178B>
- ¹⁷ Wikipedia article on the V-model <https://en.wikipedia.org/wiki/V-Model>
- ¹⁸ For more information, see Appendix F
- ¹⁹ Reji, Peter & Natarajan, Karuppannan & Shobha, K.R.. (2020). Challenges in implementing a wireless avionics network. Aircraft Engineering and Aerospace Technology. ahead-of-print. 10.1108/AEAT-07-2019-0144.
- ²⁰ Jin-Shyan Lee, "Performance evaluation of IEEE 802.15.4 for low-rate wireless personal area networks," in IEEE Transactions on Consumer Electronics, vol. 52, no. 3, pp. 742-749, Aug. 2006, doi: 10.1109/TCE.2006.1706465.
- ²¹ Guglielmo, Domenico & Anastasi, Giuseppe & Seghetti, Alessio. (2014). From IEEE 802.15.4 to IEEE 802.15.4e: A step towards the Internet of Things. Advances in Intelligent Systems and Computing. 260. 135-152. 10.1007/978-3-319-03992-3_10.
- ²² P. Park, P. Di Marco, J. Nah and C. Fischione, "Wireless Avionics Intracommunications: A Survey of Benefits, Challenges, and Solutions," in IEEE Internet of Things Journal, vol. 8, no. 10, pp. 7745-7767, 15 May 2021, doi: 10.1109/JIOT.2020.3038848.
- ²³ Gao, Shang & Dai, Xuewu & Hang, Yu & Guo, Yuyan & Ji, Qian. (2018). Airborne Wireless Sensor Networks for Airplane Monitoring System. Wireless Communications and Mobile Computing. 2018. 10.1155/2018/6025825.
- ²⁴ Park, Pangun & Ergen, Sinem & Fischione, Carlo & Lu, Chenyang & Johansson, Karl. (2018). Wireless Network Design for Control Systems: A Survey. IEEE Communications Surveys & Tutorials. PP. 10.1109/COMST.2017.2780114.
- ²⁵ Contiki-ng wiki <https://github.com/contiki-ng/contiki-ng/wiki>
- ²⁶ F. Osterlind, A. Dunkels, J. Eriksson, N. Finne and T. Voigt, "Cross-Level Sensor Network Simulation with COOJA," Proceedings. 2006 31st IEEE Conference on Local Computer Networks, 2006, pp. 641-648, doi: 10.1109/LCN.2006.322172.
- ²⁷ Contiki-ng wiki <https://github.com/contiki-ng/contiki-ng>
- ²⁸ Zolertia website on RE-MOTE <https://github.com/Zolertia/Resources/wiki/RE-Mote>

²⁹ C. Dombrowski and J. Gross, "EchoRing: A Low-Latency, Reliable Token-Passing MAC Protocol for Wireless Industrial Networks," Proceedings of European Wireless 2015; 21th European Wireless Conference, 2015, pp. 1-8.

³⁰ S. Duquennoy, A. Elsts, B. A. Nahas and G. Oikonomo, "TSCH and 6TiSCH for Contiki: Challenges, Design and Evaluation," 2017 13th International Conference on Distributed Computing in Sensor Systems (DCOSS), 2017, pp. 11-18, doi: 10.1109/DCOSS.2017.29.

³¹ Roberts, L.. "ALOHA packet system with and without slots and capture." Comput. Commun. Rev. 5 (1975): 28-42.

³² Wikipedia article on 6LoWPAN <https://en.wikipedia.org/wiki/6LoWPAN>

³³ S. Duquennoy, A. Elsts, B. A. Nahas and G. Oikonomo, "TSCH and 6TiSCH for Contiki: Challenges, Design and Evaluation," 2017 13th International Conference on Distributed Computing in Sensor Systems (DCOSS), 2017, pp. 11-18, doi: 10.1109/DCOSS.2017.29.

³⁴ Zolertia RE-mote data sheet <https://github.com/Zolertia/Resources/blob/master/RE-Mote/Hardware/Revision%20B/Datasheets/ZOL-RM0x-B%20-%20RE-Mote%20revision%20B%20Datasheet%20v.1.0.0.pdf>

Appendix A: Report on aircraft industry ambitions and roadmaps

Table of Contents

- 1. Intro..... 2
- 2. State of the art..... 3
 - 2.1. Aviation state of the art 3
 - 2.1.1. Fly By Wire 3
 - 2.1.2. Avionics Bus 4
 - 2.2. Wireless state of the art..... 4
 - 2.2.1. Radio Frequency technologies 5
 - 2.2.2. Optical communications..... 5
 - 2.2.3. Surface Waves 6
- 3. Current Industry Roadmap 6
 - 3.1. The prospect of Electrical Aircraft..... 6
 - 3.2. Limits of Wireless Technology – Key enablers 7
 - 3.3. Wired vs Wireless..... 8
 - 3.4. Divergent Solutions: Copper, Power-Line and Wireless 8
 - 3.5. Entertainment applications 8
 - 3.6. Control applications..... 8
- 4. Standardization and Consortia 9
 - 4.1. WAIC (Wireless Avionics Intra Communications) 9
 - 4.2. NASA (National Aeronautics and Space Administration) 9
 - 4.3. Caneus (International Collaborative Aerospace & Energy development)..... 9
- 5. Future applications expectations 10
 - Application 1: Fly by Wireless (Distant Future)..... 10
 - Application 2: Wireless engine prognostic (Distant Future) 10
 - Application 3: Structural sensing (Near Future)..... 11
 - Application 4: Landing gear monitoring (Near Future)..... 11
 - Application 5: Air pressure and quality monitoring (Distant Future) 11
 - Application 6: Anti-Ice/Rain sensing (Near Future)..... 11
 - Application 7: Smoke detectors (Near Future)..... 12
 - Application 8: Intelligent lightning system (Near Future)..... 12
 - Application 9: Smart cabin system (Near Future) 12
- 6. Conclusions..... 12
- 7. Literature and Sources 13

1. Intro

The aerospace sector is one of the most emblematic and iconic fields of human ingenuity. Humanity always dreamt of conquering the skies and the stars thus making the industry's milestones celebrated worldwide. Additionally, many innovations and breakthroughs were first conceived for the industry's purposes and were later adopted for other uses. In total, the industry is respected, if not revered, and its product – the aircraft – is thought as an extremely reliable means of transportation.

The modern aircraft is the pinnacle of system's engineering. It is composed of many individual parts and systems and each one of those has to be certified by extensive testing. Some of the systems in the aircraft are: the Navigational system, the Power system, the Flight Control system, the Avionics system, the Engine control system, the Water supply System, the Hydraulics System and the Cabin pressure system to name a few. In order for these systems to properly operate, to integrate with the main system and to communicate with the flight computer they are connected in a sophisticated data network. It would be no exaggeration to claim that this system forms the backbone of an airplane.

Currently, this data network is supported by wiring, which runs through the entirety of the aircraft connecting the necessary components. There are various protocols (ARINC, AFDX) that organize the way that information is being delivered and guarantee key performance qualities like low latency and high delivery rate. The most important part of the data network is arguably the Flight control system. The idea of using wire instead of mechanical or hydraulic systems to transfer the pilot's input to the aircraft is called Fly-by-Wire. This system is usually triple or quadruple redundant in order to avoid accidents and is considered robust and efficient.

However, researchers and manufacturers think that we are approaching the limit of what this design can offer to us. The last decades, a significant amount of functionalities were added to the aircraft. In order for them to be supported, they had to be connected to the data network. The result is that the wiring system is now heavily congested. Its total weight in an average aircraft is now around 6 tons (~ 2% of the total weight) resulting in costs from fuel consumption, lost space and difficulty in troubleshooting and changes in the design. Adding to this pressure, the current political and social climate places huge emphasis on ecological and sustainable development. The result is that companies with assets on the aviation sector feel the need to improve this system and mitigate its weaknesses and limitations.

Aviation companies that are looking to dominate this new landscape and become leaders in their field are employing researchers and engineers to make the wiring more efficient. Through this process, multiple solutions are being considered. For instance, efforts are being made on optimizing the routing, on using only the necessary electromagnetic shielding and on making thinner cables. Moreover, disruptive solutions like power line communications and wireless systems are also considered.

In order for these technologies to be adopted, there are some issues that have to be determined. Specifically, the maturity and reliability need to be investigated. Additionally, managers and stakeholders are also sceptic about the business case of such applications. This project will try to answer or at least provide the tools for answering these questions considering the wireless applications.

2. State of the art

In order to come up with the correct design for the project it is crucial that we understand the state of the art in both current aviation technology and wireless communications. In this chapter, the state of the art for both of these systems will be analyzed.

2.1. Aviation state of the art

2.1.1. Fly By Wire

As has been discussed in the intro section, the Flight Controls are one of the most essential parts of the aircraft. The mission of this system is to translate the pilot's commands to the appropriate action of the vehicle's actuators (ailerons, flaps, elevators etc.). Additionally, modern aircraft design considers a sub function: to guarantee that the resulting action will be safe and result in a stable system.

Such complex functions can only be performed in a sufficient quality by a flight computer. The basic architecture can be described as a closed loop. The input to the system is the pilot's

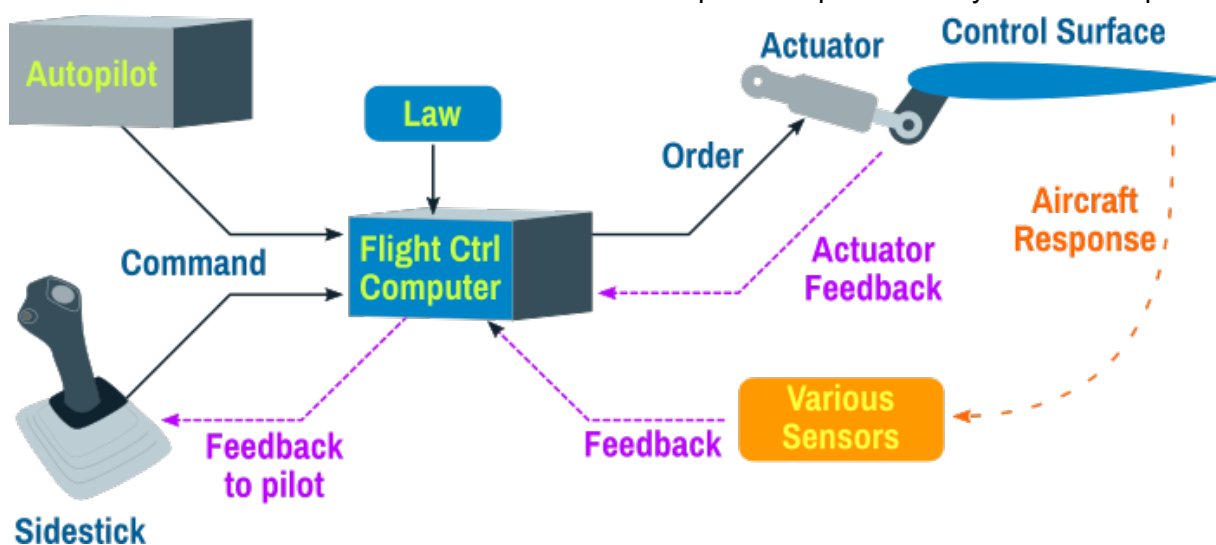

Figure 1: Fly by Wire Architecture (source: Aviation Stack exchange)

command as issued from the cockpit instruments. These commands are then received from a flight computer which calculates how to achieve the wanted output and estimates the resulting position of the craft. After the flight computer resolves the processing, it sends the appropriate signal to the actuators. Then, the sensed feedback of the action as well as the state, position and direction of the craft is fed to the flight computer. Naturally, this process is ongoing for the duration of the flight. The picture below is representative of this architecture.

Since the whole process is digital and the information and actions are being represented by a digital signal, this process needs to be supported by some sort of data transfer network. This is commonly performed by wiring, hence the name Fly-By-Wire. There can be as much as four instances of the wiring for redundancy purposes. As a side note, it should also be mentioned that most of communicating parts of this system also have their own computers to handle their activity.

Fly By Light

Based on the established and trustworthy Fly-By-Wire technology, developers are trying to improve their design by replacing the copper wiring with other technologies. The idea that seems to be more prevalent among the industry seems to be replacing the copper with optical fiber, hence *Fly-By-Light*. This approach has already been tested: notably the Japanese aircraft Kawasaki P-1 introduced in 2013 has a Fly-By-Light or Fly-By-Optics system. The main

benefits are higher data transfer rate, immunity to electromagnetic interference, and lighter weight. However there is significant troubleshooting overhead: because the computers are still electronic based this system relies on optics to electronics converters which are usually prone to errors.

2.1.2. Avionics Bus

Since the aircraft data network connects different devices by definition, it needs to have a consistent and defined way for these systems to communicate. In other words, the data bus requires a common protocol to work. Depending on the mission of the aircraft, the system under question and the developing company, one of the following protocols maybe used: ARINC 429, ARINC 629, Mil-Std-1553, CAN, AFDX, and TTP^{1 2}. The most widely used are ARINC 429, CAN and AFDX which will be discussed in the following sub chapters.

ARINC 429 (Aeronautical Radio, Incorporated)

ARINC 429 is the standard protocol for avionics. Its nominal bit rate is 100 kbit/s (actual data rate around 50kbit/s) and has predictable and very low latency and jitter. Its architecture is point to point (simplex) has no error handling mechanism and has a dedicated medium. The result is a robust system that is relatively inexpensive but requires a significant amount of wiring.

CAN Bus (Controller Area Network)

The CAN bus is a protocol that was originally developed for the automotive sector but has been also adopted by the aerospace and other industries due to its performance characteristics. Its nominal data rate is 1 Mbit/s (actual data rate around 300kbit/s) and has probabilistic latency and jitter (they depend on network load). Its architecture is point to multipoint (half-duplex) and the medium is shared via a CSMA/CA mechanism. However, in order to guarantee proper handling for critical packets, it employs an arbitration mechanism for the medium access giving priority according to the ID of the sending device. Additionally, it has some error handling mechanism based on monitoring and shutting down erroneous nodes. It is very inexpensive and allows for better overall throughput.

AFDX (Avionics Full-Duplex Switched Ethernet)

The AFDX protocol is an avionics protocol based on the IEEE 802.3 (Ethernet) architecture. Its nominal data rate is an impressive 100 Mbit/s (the actual data rate is varied) and, like the Ethernet has probabilistic latency and jitter (depending on network load) – they are however upper bound based on virtual link technology. It has error handling and error correction mechanism and has multipoint to multipoint (full-duplex) architecture. It is the most efficient and fast of all protocols and it also allows easy integration with typical Ethernet devices. However, it is significantly more expensive to implement than the other protocols.

2.2. Wireless state of the art

Since Nikola Tesla's and Marconi's innovations and experiments in the early 20th century wireless technology has developed significantly. The radio, television, mobile phone and wireless computers are today considered almost essential. Especially, during our current digital age shaped by 5G and other technologies we see many promising applications: Internet of Things, autonomous cars and sensor technologies are already being tested and improved.

This high interest in wireless technologies has guaranteed funding to many research groups. Their work has been bountiful and resulted in the creation for many technologies that can become the key enabler for wireless intra communication in aircraft. The most significant of these technologies is discussed in detail in this chapter.

2.2.1. Radio Frequency technologies

The most widespread wireless technology is by far the traditional Radio approach. The engineers are experienced in this kind of technology and the supplier market offers a wide range of products. Especially, the technology covering the ISM band (Industrial, Radio and Medical, frequency around 2.4 GHz) is popular and myriad of devices or totally integrated solutions can be found at a reasonable price. However, since consumer electronics already operate on this band it is difficult to rely on it for use in the aircraft. In combination with the hard standardization and verification required in the aircraft, the selection of a frequency band becomes critical (more on that on the Standardization and Consortia chapter). Since it is possible to adapt an already existing protocol to another frequency, here the potential enabling technologies for wireless intra communications are presented.

Wireless Local Area Networks

Technologies that can form a WLAN (Wireless Local Area Network) usually refer to wireless technologies with an effective range around 100 meters where many devices in the same geographic location can join the network. Typical applications of these protocols can be found in households, offices, industrial settings and even Wireless Sensor Network applications. Key protocols are the following.

802.11 Family

Also commonly known as Wi-Fi, it is probably the most successful of the protocols. It boasts many revisions and is being used all over the world for any kind of application. What is common among its different versions is the combination of some form of OFDM (Orthogonal Frequency Division) Modulation and CSMA/CA medium access protocol. The protocol also contains mechanisms for authentication, safety and fairness among the connected devices. It is usually used as an access point to facilitate the wireless connection of devices to a wired network. It can also support other topologies.

802.15.4

Protocols that belong to this family are usually smaller and cheaper than their Wi-Fi counterparts. Instead of forming Local Area Networks, the term Personal Area Network is used indicating the smaller range that these networks typically display. They are also very efficient and can achieve a better reception ratio compared to other technologies given harsh conditions (low power and lossy network). This protocol is mostly used of Wireless Sensor Network applications.

TSCH:

Specifically, the amendment (Time Slotted Channel Hopping) TSCH addresses the reliability of this protocol. By combining TDMA and FDMA (Time/Frequency Division Multiple access) techniques, the in time delivery of messages can be guaranteed. It is mostly used for industrial Internet of Things applications, where precision and predictability is important.

RFID

Radio Frequency Identification is a passive radio based technology meant for tracking and simple message transmission (tag). Apart from commercial applications (barcode, animal tracking etc.) RFID tags are also used in low power networks. The idea is that a node remains dormant in order to preserve energy and activates itself once it receives the appropriate signal from an RFID reader. This is important when considering the powering of our system and is already been investigated.

2.2.2. Optical communications

Apart from Radio Frequency technology, there are other ways that a message can be delivered wirelessly. One approach that has been getting traction is Optical communications: using light

in free space to transmit data. Usually these technologies are easy to deploy, don't need regulation and are more secure. However, they depend on line-of-sight and are very sensitive to environmental factors making them reliable only when used in close proximity. The most widely known examples are presented below.

Infrared

Infrared technology is based on infrared light: radiation that has a frequency lower than visible light (430 THz – 300 GHz). This technology can reach high speeds (hundreds of Mbit/s) while providing high security (high attenuation at obstacles). The drawback is that line-of-sight is essential and the range is severely limited. This technology is typically used for easy remote control.

Li-Fi

Li-Fi is the most promising optical communication technology. It utilizes the whole visible light spectrum and parts of the infrared and ultraviolet. The employed mechanisms make it undetectable by the human eye: the standard can operate with dimmed light and the frequency of the light switching (the primary method of information exchange) is too high. Furthermore, Li-Fi boast speeds that reach several Gbit/s and can even work without direct line-of-sight (reflected light is enough). The benefits of such technology is that it has practically unlimited and unregulated bandwidth and that it guarantees zero interference with other system. However, it is still not extensively tested and its range is medium at best (around 10 meters).

2.2.3. Surface Waves

Wireless transmission doesn't necessarily involve communications with no wave guide. Engineers and physicists have come up with a way to transmit data with electromagnetic waves that travel along a composite surface³. The technology can guarantee 3Gbits/s and needs no change to the already existing material; transducers embedded in the fuselage are enough. After demonstrations, a patent has been filled in 2016 and the research phase is speculated to end in ten years' time.

3. Current Industry Roadmap

In the past decades, the aircraft manufacturing industry was characterized by a strong emphasis on traditional, proven and low operational cost solutions. However, due to external political pressure, relevant policies and steep competition, as discussed in the introduction, the industry is trying to innovate. Focus is given on maintaining a strategic advantage over the competition and being the first to market new disruptive technologies. One of these technologies is the wireless intra communications. Below relevant industry expectations can be found.

3.1. The prospect of Electrical Aircraft

The most prominent envisaged change seems to be about the powering of the aircraft. Specifically, the introduction of electrically powered airplanes is being investigated and pushed. This change will have a significant impact on how new aircraft will be designed, as previous tools and methods won't have the same result. This calls for a general redesign of the aircraft and its various systems. It is a prime opportunity to challenge preconceptions and design from a fresh perspective.

Of course, this is also true for the aircraft's data network. Provided that the power system will be electrical, there is going to be cabling for high voltage power distribution. One of the ambitions of the industry and an opportunity for the suppliers is to combine the data line with this power distribution by utilizing power line communications technology. Additionally, for sensors and nodes that are expected to change often, a wireless access point could be

provided. The exact boundaries remain unclear in this scenario, but the industry is converging on some sort of combination of copper wiring, high voltage wiring, power line communications and wireless links.

3.2. Limits of Wireless Technology – Key enablers

1. *Unreliability*: A common misconception among engineers and specialists is that Wireless technology is by nature unreliable and not suited for the delivery of critical information. While it is true that there is a probabilistic element in wireless transmission, modern techniques mitigate this issue and can guarantee certain key performance characteristics. Such techniques are key enablers in the wireless intra communications case since reliability is very important in flight applications (especially in a fly-by-wireless scenario). Important examples are **diversity, frequency hopping, quality of service differentiation** and **architectures without a single point of failure**.
2. *Latency*: All information transportation has some inherent latency: propagation, even in free space, takes time. However in wireless transmission, especially when lots of nodes share the same medium, the situation is more complicated. If the nodes attempt to access the medium at the same time, the result is destructive and the packet has to be transmitted again, thus increasing the latency. Moreover, sometimes latency is introduced by the architecture. If the packets needs to travel through different nodes in order to reach its destination then significant increase in latency is observed. In order to combat this, certain tools have been developed that function as enablers for a wireless intra communication network. Important examples are **TDMA** and **FDMA** (time/frequency division multiple access), **edge computing, shorter frames** and **architectures that favor direct links**.
3. *Availability/Security*: One of the risks traditionally associated with wireless technology is the vulnerability to malicious attacks. All that it takes for an intruder to have access to the exchanged information is a device that can intercept electromagnetic waves. Additionally, it is also relatively simple to attack the network's integrity by transmitting on the same frequency with a high power level (jamming). Sadly, there is no clean answer to such weaknesses. There are however techniques that make it harder to access the network and to react to a jamming attack. These techniques constitute key enablers for wireless intra communications, as without them any such network is easily compromised. Important examples are **Authentication, frequency hopping, session keys** and **physical layer security**.
4. *Electromagnetic Susceptibility*: A well-designed solution should take into account the nature of the transmission medium. Specifically, selecting an appropriate frequency is crucial since many systems operate simultaneously in a modern aircraft. That means that their proper functioning should be guaranteed while our nodes should function as intended in this harsh conditions. Furthermore, the aircraft is flying in a hostile environment. The presence of other aircraft or even a sudden lightning strike could impact our system. It goes without saying that we have to build a resilient system than can work acceptably in every scenario. Some important examples of enabling techniques⁴ are **shielding, TDMA, filtering** and **coding**. (differentiate systems)
5. *Powering*: The benefits from going wireless are severely limited if we still rely on a cable for powering. That means that for every proposed design for wireless intra communications we come up with, it is crucial to include a solution for the powering problem. Thankfully, market focus on consumer electronics and wireless sensor nodes has resulted in the development of technologies that can enable a truly wireless network. Such developments are the long lasting **lithium battery, duty cycling, passive radio identification** and **ambient energy harvesting**.

3.3. Wired vs Wireless

Since wireless technology is by definition disruptive considering a wiring integration company, the motivation for developing a wireless product should be investigated. The simplest argument for the development of such technologies is the competition. Since solutions like this are already under investigation, it is a matter of time before the competition comes to the market with such products. The simplest motivation then would be not to be singled out of the market.

However, this is not the only reason. Developing such a technology could have many emergent properties. For example, since in wireless networks it is easy to introduce new nodes and functionalities, the supplying company could evolve in a lifelong partner of the aircraft manufacturer. Additionally, wireless technology would implicate less operational costs and an increased flexibility for the design allowing for solutions that were unthinkable in the past.

Lastly, it is difficult to imagine the complete transformation of the aircraft data network to wireless. At least for the near future, the most possible outcome would be a combination of copper wiring, power line communications and wireless. Provided this is the case, it seems to be a natural evolution for the designer of the data network to integrate other technologies in the system.

3.4. Divergent Solutions: Copper, Power-Line and Wireless

As has already been discussed in other chapters, the future of the aircraft data network seems to involve the combination of many technologies namely copper cabling, power-line and wireless communications. These technologies are very different to each other and each has its own strengths and weaknesses⁵ so finding the right balance is important. The current direction is as follows: traditional copper wiring for the flight controls, power-line communications between the avionics modules and wireless communications between the modules and their nodes. This way, overall reliability is guaranteed and the effectiveness of the network is improved. This is evocative of how other communication's networks have evolved. The current trend is wireless for access and wired for the backhaul link.

However, we should also investigate other combinations. The benefits of an all wireless system have to be investigated. Not only this will help us have a clear vision of how this technology could potentially be used in the future but it might give us insight on other uses. For example, in unmanned flights (drones) or in small aircraft, a lean wireless architecture might be the right approach.

3.5. Entertainment applications

The most obvious candidate for a wireless makeover is the infotainment system. The technology has seen extensive use and testing in terrestrial settings and the requirements are looser. This is a simple way to remove some unnecessary wiring and provide the same or even better quality services to the passengers and crew. Many companies have already signed deals to install such systems^{6 7} and rollout is expected in the near future.

3.6. Control applications

The most ambitious application of wireless intra communications would be the transition of the flight controls to wireless. From a communications perspective this is the most demanding application and requires a very robust, reliable and secure network. On the other hand, there is a lot to gain from such transition. Not only will this significantly make the aircraft lighter, but it will also remove the connectors which is a common cause of failure. Adding to that, the reduced development time and the flexibility in the design process translate to a decrease in

the operational cost and is expected to change the supplier market. However this technology is still in its infancy and hasn't progressed beyond the research stage.

4. Standardization and Consortia

The wireless intra communications project is complex and has many stakeholders and involved parties. In order for such a project to come to fruition and be useful and widely adopted, it needs a dedicated group of people that supports its development. Such support can range from advocating for system research and adoption to requirements specification and most importantly standardization. Research indicated that the most prominent groups involved with wireless intra communications are the following.

4.1. WAIC (Wireless Avionics Intra Communications)

The WAIC group⁸ is part of the AVSI (Aerospace Vehicle System Institute) cooperative which is led by the Texas A&M University. Their mission is to “facilitate pre-competitive collaborative research projects” in the aerospace sector, establishing an environment that encourages collaboration, influences standards and policies and creates a voice for the industry. They have many high profile members: Airbus, Embraer, Honeywell, Lufthansa, Rockwell Collins, Thales, United Technologies, Zodiac Aerospace and NASA are specifically involved in the WAIC project.

They have been advocating for wireless intra communication in aircraft since 2007. Their activities include doing research to support the technology and campaigning for standardization and acceptance from ITU-R (International Telecommunication Union for Radio) and ICAO (International Civil Aviation Organization). This has resulted in a frequency band being dedicated to wireless aircraft intra communications for safety (4.2 – 4.4 GHz)⁹ after a compatibility study¹⁰ and application specifications¹¹. Furthermore, since the allocated frequency is also used by another aircraft system – the radio altimeter – the WAIC team initiated tests with member equipment in 2017 to verify that the two systems can properly coexist.^{12 13}

This consortium seems to be held in great esteem¹⁴ and reports about their activities seem to be endless. At this point, it seems wireless intra communications in aircraft are almost synonymous to WAIC. They take part in various high profile conferences and have been campaigning their ideas for a long time. In the near future, their expectations are to be involved with ICAO to make a SARP (Standards and Recommended Practices) for WAIC.

4.2. NASA (National Aeronautics and Space Administration)

There is no need for introductions for the well-known aerospace giant that is NASA. However, what is not so widely known is that not all projects NASA is involved with have direct relationship with space exploration. For instance, NASA is also doing research on aviation technology as is indicated by their collaboration with WAIC.

However, their involvement with wireless intra communications doesn't end there. They are an ardent supporter of the Fly-By-Wireless paradigm and have published various papers for its adoption. Areas of focus include highlighting the problems of wiring and how they can be solved with wireless¹⁵, showcasing and evaluating potential tools and architectures¹⁶ and even performing feasibility tests.¹⁷

4.3. Caneus (International Collaborative Aerospace & Energy development)

Caneus Fly-By-Wireless Sector Consortium¹⁸ is part of the broader CANEUS initiative. This Canadian based cooperative is aiming to help in the transitioning of new and emerging technologies from the concept to the system level. Their goal is to create a synergistic

collaborative environment, in which all major stakeholders take part, helping to reduce developmental costs time to market and global supply chain penetration. Their partners include NASA, Rolls Royce, Bombardier, Airbus, Meggitt, Goodrich, Boeing Space Exploration and Defence R&D Canada.

However the group doesn't seem to be active after 2010. They have held various workshops with some of their partners and Honeywell mostly dealing with brainstorming on wireless intra communications and potential problems and architectures.^{19 20}

5. Future applications expectations

The future of aircraft wireless intra communications seems exciting and full of promises. An inventory of the commonly discussed applications can be found below.

Application 1: Fly by Wireless (Distant Future)

The history of flight control systems is a typical case of industrialization. The current Fly-By-Wire system replaced the hydro-mechanical systems of the past. However, we are currently undergoing the next revolution: the digital era is upon us. Drawing inspiration from such trends, one might be tempted to replace all the wiring in the flight controls and install a wireless system. Such a fly by wireless system would have many benefits coupled of course with high risks. This is the most emblematic application of wireless to aircraft intra communications.

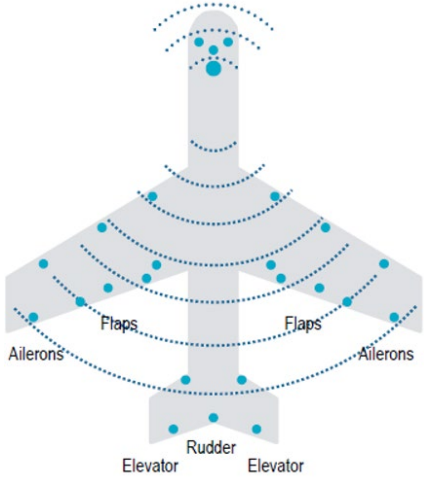

Figure 2: Fly-By-Wireless (source: Roland Berger document)

Redundant Fly by Wireless (Near Future)

A complete Fly by Wireless system might be considered extremely risky. To mitigate this, WAIC has proposed the following application: install a Fly by Wireless system on top of a Fly by Wire system and use the first as a back-up! This solution would help test the application extensively and cultivate a sense of reliability on the users.

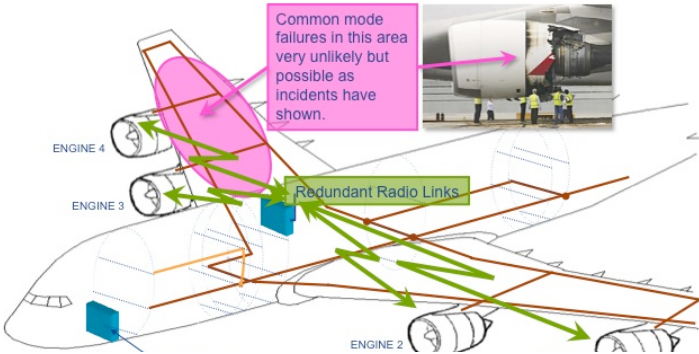

Figure 3: Redundant Fly-By-Wireless (Source: WAIC)

Application 2: Wireless engine prognostic (Distant Future)

Arguably, the engine is one of the most essential parts of the aircraft and one prone to errors. Currently, there is a sophisticated system for controlling the engine called FADEC (full authority digital engine control). This system also allows for some troubleshooting and error handling. However, with wireless technology as an enabler, we can move on step further: a real time prognostic systems is feasible. Having such a system would allow for an estimation for



Figure 4: Wireless engine prognostic (Source: QuEST Global)

the engine's remaining operational lifetime and detection of errors before they come up.

Application 3: Structural sensing (Near Future)

A common cause for aircraft failures is actually mechanical issues and structural problems. Currently, the only way to safeguard against such incidents is strict quality assurances and inspections. However, with wireless technology it is possible to install structural sensors in key parts in the aircraft's body. The sensors can relay useful information on the wear of the material detecting fatigue and crack forming before they can become a threat.



Figure 5: Structural Sensors (Source: Flight Safety Foundation article)

Application 4: Landing gear monitoring (Near Future)

One of the benefits that wireless technology has compared to its competition, is its flexibility. With this technology it is now possible to reach places that it previously was very hard to reach or even impossible, such as moving parts. That means that now it is easier to install sensors on the landing gear and have access to information on its position, on the brake temperature and the tire pressure. We can even install actuators to wirelessly operate the landing gear, resulting in an all wireless landing gear system.

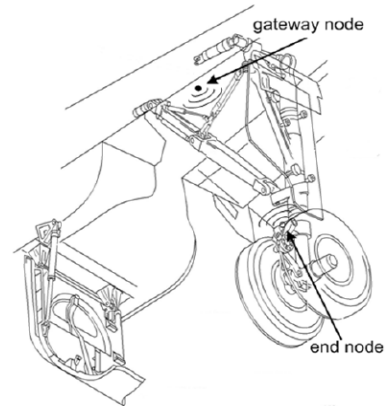

Figure 6: Landing gear monitoring (Source: WAIC)

Application 5: Air pressure and quality monitoring (Distant Future)

Aircraft cabins have the reputation of having bad air quality. In part, this is due to the origin of the air as it is either recycled or from the bleed system (engine intake). Wireless technology could help, by adding more sensors in crucial places measuring various parameters. Based on the sensor feedback, a sophisticated control mechanism can come into place targeting specific pathogens and purifying the air. It is also possible to combine this system with cabin pressure controls resulting in a centralized wireless air control system.



Figure 7: Air quality system (Source: facts.aero)

Application 6: Anti-Ice/Rain sensing (Near Future)

Depending on the altitude and the environment that aircraft fly in, they face all sorts of problems. Such a problem is the forming of ice on various parts of the aircraft (engine, flaps, etc.). In order to avoid that, many techniques have been developed but what is missing is clear information on the forming of ice. Wireless sensor technology allows us to have that information. Improving and replacing the existing system will have significant impact in decreasing the weight of the wiring and the effectiveness of the anti-ice system.



Figure 8: Anti Ice System (Source: boldmethod.com)

Application 7: Smoke detectors (Near Future)

A sub-system that all medium sized and larger aircraft have is the smoke detection system. This system is responsible for detecting fires both in the cabin and in other areas of interest (the engine). In this case, the data that need to be transmitted are easy to handle and the overall system is rather simple. Because of that, this system is a prime candidate for a wireless makeover.



Figure 9: Wireless smoke detectors (Source The Wire Cutter)

Application 8: Intelligent lightning system (Near Future)

The lighting system of an aircraft is again, relatively simple and easy to replace with wireless links. However, in this case the benefits are not so profound since in most cases power will continue to be provided by cable. That being said, a wireless control of the lighting system or an emergency lightning system could be potential uses of wireless technology.



Figure 10: Futuristic lightning system (Source: aircraftinteriorsexpo)

Application 9: Smart cabin system (Near Future)

Last but not least, commercial aircraft have some extra systems dedicated to the passengers. Typical functions include entertainment, information or passenger to crew interaction such as ordering food and beverage, seatbelt notifications and so on. Since these systems are not safety critical and share many similarities with consumer applications, they pose ideal candidates for our project, removing a significant amount of wiring.

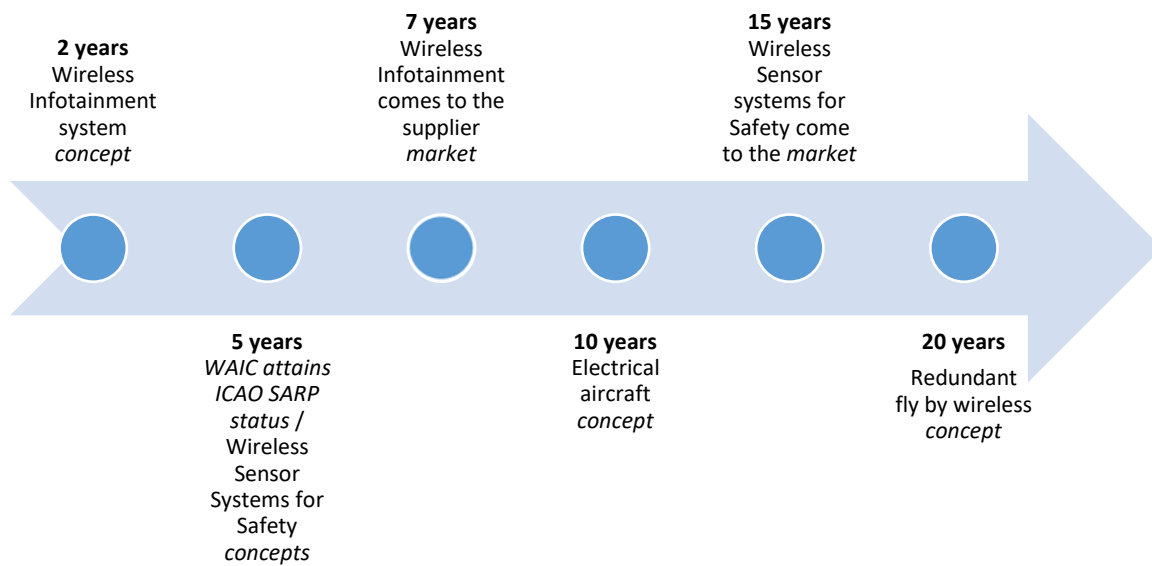

Figure 11: Smart cabin system (TU Delft project)

6. Conclusions

The aircraft industry is undergoing lots of transformations at the moment. Emphasis is given on maintaining the edge over competitors and innovative and elegant solutions are favoured. The same principle applies to the aircraft data network. Research groups and various consortia are investing time and money on alternative network architectures, one of which is wireless intra communications. Research is rapidly converging and standards and frameworks are being defined. It seems that the involved parties understand the motivation for such a transition and estimate that the technology is mature enough and capable of supporting such endeavor. What is missing is the appropriate standardization (work in progress) and a concise system approach that can combine all the elements to create a reliable and secure solution. Of course, for the success of our project there is also one more necessary ingredient: a clear strategic direction so that we know what end result we want to achieve and what trade-offs we should opt for.

As an ending note, below a diagram of the expected evolution of aircraft wireless intra communications can be found.



7. Literature and Sources

- ¹ ["Protocols for Aerospace Control Systems A Comparison of AFDX, ARINC 429, CAN, and TTP." \(2009\).](#)
- ² [Fuchs, Christian. \(2012\).The Evolution of Avionics Networks from ARINC 429 to AFDX. Innovative Internet Technologies and Mobile Communications and Aerospace Networks \(IITM & AN\). 65.](#)
- ³ Who needs wires? 18 February 2019 [article](#) by aero-mag
- ⁴ [Akram, Raja Naeem & Markantonakis, Konstantinos & Kariyawasam, Sharadha & Ayub, Shahid & Seeam, Amar & Atkinson, Robert. \(2015\). Challenges of security and trust in Avionics Wireless Networks. 4B1-1. 10.1109/DASC.2015.7311416.](#)
- ⁵ PLUS Avionics White paper by plc tec swiss innovation
- ⁶ Signify lights the way for Li-Fi in the sky, [bits & chips article](#) by Collin Arocho, [Signify website details](#)
- ⁷ Team TU Delft wins award for best aviation innovation, [TU Delft article](#)
- ⁸ [WAIC website](#)
- ⁹ [Recommendation ITU-R M.2085-0 \(09/2015\)](#) Technical conditions for the use of wireless avionics intra-communication systems operating in the aeronautical mobile (R) service in the frequency band 4 200-4 400 MHz
- ¹⁰ [Report ITU-R M.2319-0 \(11/2014\)](#) Compatibility analysis between wireless avionic intra-communication systems and systems in the existing services in the frequency band 4 200-4 400 MHz
- ¹¹ [Report ITU-R M.2283-0\(12/2013\)](#) Technical characteristics and spectrum requirements of Wireless Avionics Intra-Communications systems to support their safe operation
- ¹² [L. Hanschke, L. Krüger, T. Meyerhoff, C. Renner and A. Timm-Giel, "Radio altimeter interference mitigation in wireless avionics intra-communication networks," 2017 15th International Symposium on Modeling and Optimization in Mobile, Ad Hoc, and Wireless Networks \(WiOpt\), Paris, 2017, pp. 1-8. doi: 10.23919/WIOPT.2017.7959893](#)
- ¹³ [WAIC presentation in Bangkok, update on WAIC safe operation alongside radio altimeter](#)
- ¹⁴ War on Wiring, [article](#) by Aerospace America
- ¹⁵ "Fly-by-Wireless": A Revolution in Aerospace Vehicle Architecture for Instrumentation and Control [Abstract](#) Principle Author: NASA/JSC/George Studor
- ¹⁶ [Avionics Architectures for Exploration: Wireless Technologies and Human Spaceflight](#) Montgomery B. Goforth, James E. Ratliff, Richard J. Barton, Raymond S. Wagner, and Chatwin Lansdowne NASA Johnson Space Center (JSC) Houston, TX, 77058, USA
- ¹⁷ [NASA/TM-2016-219364 Enabling Wireless Avionics Intra-Communications](#) Omar Torres, Truong Nguyen, and Anne Mackenzie Langley Research Center, Hampton, Virginia
- ¹⁸ CANEUS Fly-By-Wireless [website](#)

¹⁹ Caneus 2007 [workshop](#) with Honeywell on Wireless Systems in Space Applications

²⁰ Caneus 2009 [report](#) on Fly-By-Wireless and their departments

Executive Board

Navigation address: De Zaale, Eindhoven
P.O. Box 513, 5600 MB Eindhoven
The Netherlands
www.tue.nl

Author

Asterios Souftas

Order issuer

Fokker Elmo

Date

10 December 2019

Version

1.0

Appendix B: State of the art in enabling wireless technologies

Wireless Technologies in Future Aircraft

Abstract: This report is part of the PDEng project “Wireless technologies in future aircraft”. This document provides an introduction to important wireless topics and an investigation on wireless technologies that are relevant to the project and are key enablers in the development of a wireless aircraft intra communications system. Important aspects of radio propagation and antenna technology are presented along with various industry standards that can be used as a basis for an intra-aircraft communication system. Additionally, important aspects of wireless communications are outlined, followed by a recommended approach on system security. As a conclusion, a Pugh matrix is presented where the various technologies and protocols are weighed in allowing for a clear picture of the trade-offs that can be made in the design of such a system.

Table of contents

Title
State of the art in enabling wireless
technologies

Table of Contents

| | | |
|----------|-------------------------------|-----------|
| 1 | Intro | 4 |
| 2 | The wireless channel | 5 |
| 2.1 | Free space channel | 5 |
| 2.2 | Deviating Phenomena | 6 |
| 2.3 | Wireless channel models | 7 |
| 2.3.1 | Fading models | 7 |
| 2.3.2 | Path loss models | 7 |
| 2.4 | Coexistence and Interference | 8 |
| 2.5 | Inside the aircraft | 8 |
| 2.5.1 | ITU-R Reports | 9 |
| 3 | Antenna technology | 10 |
| 3.1 | Fundamental parameters | 10 |
| 3.2 | Antenna types | 11 |
| 3.2.1 | Dipole antenna | 11 |
| 3.2.2 | Microstrip (patch) antenna | 11 |
| 3.2.3 | Antenna array | 11 |
| 4 | OSI Layer architecture | 12 |
| 4.1 | Physical layer | 13 |
| 4.1.1 | Modulation techniques | 13 |
| 4.1.2 | Coding schemes | 15 |
| 4.1.3 | Link adaptation | 15 |
| 4.2 | Data link layer | 15 |
| 4.2.1 | Contention-based protocols | 16 |
| 4.2.2 | Contention-free protocols | 16 |
| 4.3 | Network layer | 17 |
| 4.4 | Network management | 18 |

Table of contents

| | | | |
|--|--------------|---|-----------|
| | 5 | Wireless technologies and standards | 19 |
| | 5.1 | WAIC proposed standards | 19 |
| | 5.1.1 | 802.11 a/g variant | 19 |
| | 5.1.2 | 802.15.4 variant | 20 |
| | 5.2 | IEEE 802.11 variants | 21 |
| | 5.2.1 | 802.11 ac | 21 |
| | 5.2.2 | 802.11 ad | 21 |
| | 5.2.3 | 802.11 ax | 21 |
| | 5.3 | Industrial Internet of Things technologies | 22 |
| | 5.3.1 | Time Slotted Channel Hopping | 22 |
| | 5.3.2 | 6LoWPAN | 23 |
| | 5.4 | Cellular technologies | 23 |
| | 5.4.1 | 5G New Radio | 24 |
| | 5.5 | Emerging technologies | 25 |
| | 5.5.1 | Cognitive radio | 25 |
| | 5.5.2 | Optical wireless communication technologies | 25 |
| | 6 | Security | 26 |
| | 6.1 | Security challenges | 26 |
| | 6.1.1 | Threat model | 26 |
| | 6.1.2 | Types of cyber attack | 27 |
| | 6.2 | Security suggestions | 27 |
| | 6.2.1 | Optimal security measures | 28 |
| | 6.2.2 | Core principles of a security system | 28 |
| | 6.2.3 | Key principles for a secure system | 29 |
| | 7 | Conclusions and comparison | 30 |
| | 8 | Literature and sources | 32 |
| Title | | | |
| State of the art in enabling wireless technologies | | | |

1 Intro

The transportation sector is undergoing a metamorphosis. Basic principles are being questioned and new concepts proposed. This change is motivated by pressure from governments and consumers to strongly emphasize sustainability. As a result, designers and engineers come up with new technology concepts to make transportation more environmentally friendly.

One such approach is the reduction of the weight and size of the internal (intra) vehicle data network. Because of the supported functionalities, modern vehicles require even more wiring. The current solution, while characterized by high performance and reliability, significantly increases the overall system weight. For this reason, researchers and engineers are investigating potential technologies that can improve on the traditional copper cabling method.

One such solution is the use of wireless communications to facilitate vehicle intra communication. Such a technology is promising because of its effectiveness. It allows for a more lightweight system that is easier to troubleshoot and maintain.

Specifically, in the aviation industry it is estimated that the current electrical wiring interconnection system accumulates to approximately 2% of the aircraft's weight. It is assumed that making a small part of this system wireless, the carbon footprint of each flight can be reduced up to 0.5%. This represents a major opportunity to aircraft manufacturers and integrators. It allows for aircraft who are more sustainable, meeting societal demands.

Furthermore, there are implications for other design aspects as well. A wireless data network is more adaptable and can easily be modified. As such, upgrades on aircraft functionality within its lifetime will become easier. Additionally, a wireless intra communication system would allow for functionalities that were too hard to implement in the past. Examples include dissimilar redundancy and installation of sensors on moving aircraft parts (e.g. landing gear).

However, wireless communication also has risks associated to it. Currently available protocols and hardware are not made with such applications in mind. Consequently, it is important to understand the currently available technology and make the correct trade-off decisions between the various features that are offered and the implied limitations.

The **objective** of this report is to examine the current technology that could support wireless avionics intra communication applications and assess its dependability. Focus is given only to the potential of wireless to aircraft intra communication systems. Other forms of aircraft intra communication or other types of aviation oriented communication (inter aircraft communication, air-to-ground, air-to-satellite etc.) do not fall to the **scope** of this report, and thus will not be considered.

The structure of this report is the following. First (2), an analysis to the aircraft propagation environment is presented, then (3) a survey on antenna technology which is followed (4) by an overview on the design implications on the OSI layers and (5) a presentation on potentially important wireless standards an overview on the design implications on the OSI layers as well as (6) a chapter on security issues and finally (7) a conclusion, where the key performance indicators are speculated and are used as a basis for a technology suitability comparison.

2 The wireless channel

A crucial part in every wireless system is the communication channel. Its behaviour sets the boundaries of what can be done and can be used to predict and understand possible problems. As the wireless channel can have significantly different performance characteristics compared to wired channels, it is deemed important to give a short overview of the wireless channel. Giving a complete and detailed analysis is out of scope of this report, but relevant literature will be provided. Instead, in this chapter an overview of the wireless channel will be provided with focus on its impact in system design.

In the first section, the ideal case (free space) (2.1.) will be presented. Then, in the second section an array of phenomena that are faced in real life (2.2.) will be examined. This is followed by a section on channel modeling (2.3.) as well as a section on channel coexistence and interference (2.4.). At last, a short section on aircraft wireless channels (2.5.) will be provided.

2.1 Free space channel

The simplest way to understand and model a wireless channel is to assume that everything is ideal. Specifically, assuming:

- direct line of sight between the transmitter and the receiver (influence of the earth surface is assumed absent).
- an empty (neither absorbing obstacles nor reflecting surfaces) environment – air is a good approximation.
- $d \gg l$ (d is the transmission distance and l the length of the antenna)

we get a formula describing the attenuation that a signal will suffer from its transmission at distance d . This is called the “Free space” model. The formula is explained below.

$$(Free\ space)Loss = \left(\frac{4\pi df}{c} \right)^2$$

Where d stands for the distance from the transmitter, f stands for the signal frequency and c stands for the speed of light. We see that in this scenario, the only things that impact signal strength are the frequency and the distance. In fact, these squares of these metrics have a proportional relation with the loss. That means that the further away the receiver moves from the source or the higher the signal frequency, the receiver is going to experience a weaker signal. In non-free space conditions, similar behaviour is displayed. The most significant change is the exponent, which is usually (not always) bigger than 2. This exponent is called “the path loss exponent”.

Using the same model we can also estimate the strength of the signal that the receiver itself will absorb. Assuming a transmitter with power p_T and antenna gain G_t and a receiver with gain G_r the received power can be computed as follows.

$$p_r = Loss G_t G_r p_T$$

(Power is measured in Watts: for db the above formulas have to be logarithmized)

2.2 Deviating Phenomena

The free space model is accurate enough for some applications and to illustrate the role that distance and frequency play in signal transmission. However, in reality many other phenomena affect the transmission of the signal. These phenomena usually involve wave propagation and obstacles to the line of sight. As such, they usually exhibit time dependent behaviour: the wireless channel is changing with the time.

Next follows an introduction to shadowing, reflection, refraction, scattering and diffraction: all key phenomena when investigating wireless channels.

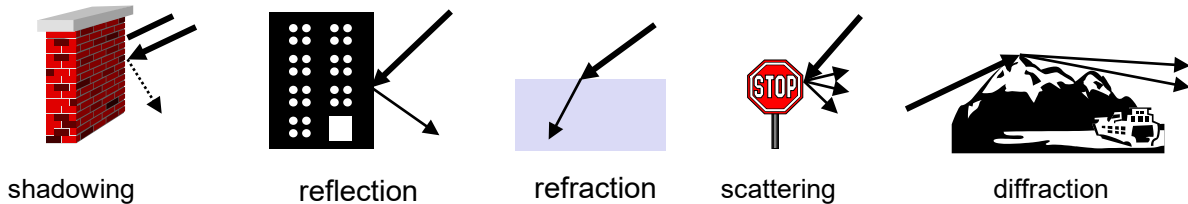

- **Shadowing** is the fluctuation of received signal power due to objects obstructing the propagation path between transmitter and receiver.
- **Reflection** is the change in direction of an electromagnetic wave at an interface between two different media so that the wave returns into the medium from which it originated.
- **Refraction** is the change in direction of a wave passing from one medium to another or from a gradual change in the “same” medium.
- **Scattering** is the reflection of the electromagnetic wave into multiple directions when it encounters some type of uneven surface.
- **Diffraction** is the bending and spreading around of an electromagnetic wave when it encounters an obstruction that blocks its line-of-sight.

Because of all this propagation phenomena, there are multiple instances of the same signal arriving on our receiver. Each instance usually arrives at a different time and with different distortions. These reflected waves interfere (destructively or constructively) with the direct wave, which causes significant fluctuations to the received signal strength. This phenomenon is called “**multi-path propagation**” and its effect on wireless communications is called “**fading**”. Fading channels have a probabilistic nature and extensive work has been put in classifying and understanding them. There are two ways to group fading channels:

The first is the **slow vs fast fading division**. Basically, if the amplitude and phase change imposed by the channel can be considered roughly constant over the period of use we say that we have a slow fading channel – otherwise we have a fast fading one.

The second is **flat vs frequency selective fading division**. If all frequency components of the signal experience the same magnitude of fading we have a flat fading channel – otherwise we have a frequency selective one.

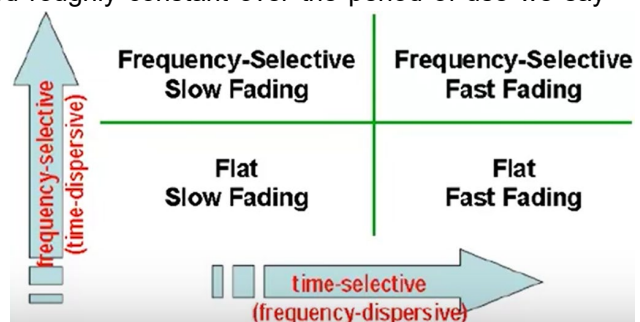

It is important to note that the same channel can be fast and frequency selective for a certain application and slow and flat for another. In order to assess the channel it is important to know the application requirements.

2.3 Wireless channel models

Wireless propagation, as is further explained in section 2.2, is probabilistic. As such, models and statistics are a necessary tool to understand the wireless channel and be in a position to predict its behaviour. The most important examples focus on modeling fading and path loss. In this section, key models will be introduced

2.3.1 Fading models

The most popular methods for modeling fading are **Rician Fading**, **Rayleigh Fading** and **Nakagami** fading. Short descriptions are given next.

- **Rayleigh fading** assumes that there is no dominant propagation component. In that case, a Rayleigh distribution can accurately predict signal attenuation. This is the most commonly used model.
- **Rician Fading** assumes that there is one path, typically a line-of-sight path, which is much stronger than the rest. Then, a Rician distribution is used to predict attenuation.
- **Nakagami distribution** is used when greater flexibility and accuracy is needed. The model has more parameters and allows it to adapt to a variety of wireless channels.

2.3.2 Path loss models

A path loss model is an empirical mathematical formula, that takes into account propagation phenomena to estimate signal attenuation. Typically, when deterministic techniques like ray tracing are not easy to do, researchers rely on a statistical model used for similar applications (frequency range, environment etc.). Providing such a model with signal frequency and transmitter – receiver distance and other parameters (specific to the model) can give us an estimate for the received signal strength. A key element common to all models is the path loss exponent, which describes how the signal attenuates with the distance (in free space the path loss exponent is 2). An introduction to some important models can be found next.

- The **COST 231** family of **models**, is used for all kind of transmissions. By using the appropriate corrections, it can be applied in urban, sub-urban, rural or even indoor areas for frequencies ranging from 150 MHz to 2 GHz. It is mostly used for cellular communications.
- The **ITU model for indoor attenuation**, as its name implies is used for transmissions inside rooms/walled areas. It works for frequencies from 900 MHz to 5.2 GHz.

- The **Log-distance path loss model** is also used for transmission inside buildings. It works for any frequency. Its strength is that it takes into account fading, incorporating a random variable (following any distribution) in its formula. However, in order for the model to work properly, it has to be provided with the right parameters (path loss exponent and fading distribution) which are typically obtained by performing field tests.

2.4 Coexistence and Interference

An important aspect of all communication is interference. Interference is any unwanted effect that distorts or disrupts a specific signal. There are many potential sources of interference. Examples include other nodes of the same application, nodes from different application, the signal itself (due to multipath propagation, see section 2.2) and other electric/electronic devices.

Wireless communication in particular are more vulnerable to interference. Since physical access to the medium is not restricted and radio resources (frequency) are scarce and thus re-used any wireless system should expect some kind of interference. To illustrate how many applications can occupy the same frequency band, here is an overview of applications using the 2.4GHz band.

Additionally, it is also possible for a malevolent party to transmit high power signals in the same frequency band as our application. Such interference can make correct signal reception impossible. This tactic is called “jamming” and represents a threat in safety critical systems.

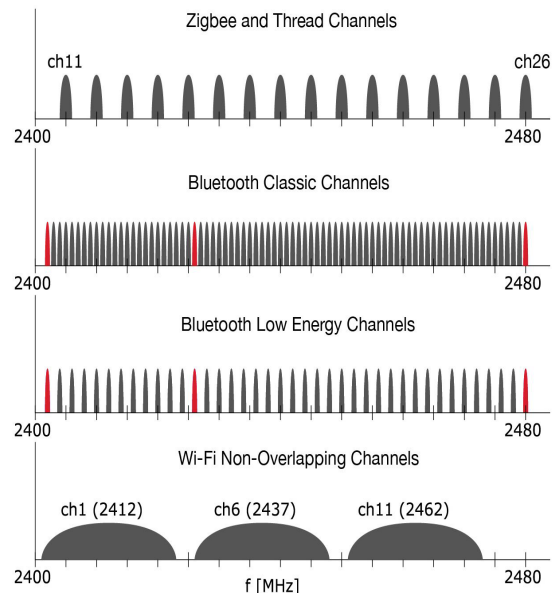

Thankfully, there is plethora of methods to combat interference and increase or make better use of an application’s SNIR (Signal to Noise and Interference Ratio). The most important factors include modulation and coding schemes, signal power, medium access techniques, shielding and diversity. These are discussed in more detail in chapter 5.

2.5 Inside the aircraft

The interior of a modern aircraft is a very different environment from outdoor areas or office buildings. Inside the cabin or crew areas there are many obstacles that can be found. Apart from the seats, galleys, beverage carts and other objects there is an important human presence. Passengers and crew are also mobile during the flight adding complexity to wireless propagation. Furthermore, the fuselage of the aircraft is usually compromised of metals. This means that the body of the aircraft usually acts as an electromagnetic shieldⁱ, not allowing signals to go inside or to propagate outside. Additionally, depending on the deployed frequency, we may expect interference from electronic devices like passenger devices,

avionics and the engine. A picture outlining different radio applications inside an aircraft can be found next.

All this means that we should expect Non line-of-sight propagation, multipath phenomena and a time varying behaviour.

The propagation environment inside aircraft has been studied in many research papers^{ii iii iv}. However, wireless avionics intra communications have different requirements that the applications examined in these papers. This means that we need to rely on research done with wireless avionics intra communications in mind.

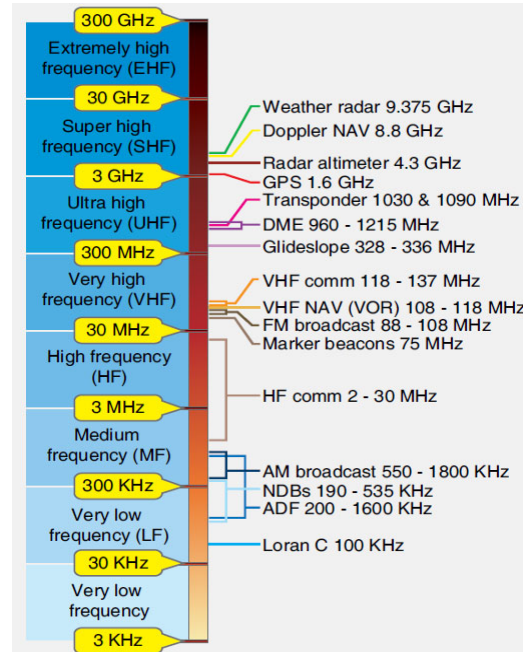

2.5.1 ITU-R Reports

The ITU-R (International Telecommunication Union – Radiocommunication sector) in collaboration with WAIC (Wireless Avionics Intra Communications) has published several reports on the WAIC case.^{v vi} Among others, these reports contain a description and an analysis of the wireless channel.

Key findings include the calculation of a **path loss exponent**, a **fading model** and a **path loss model**. Specifically,

- **the path loss exponent** was found to be:
 - 2 in compartments where there are no absorbers (Avionics compartment, Nacelles etc.)
 - 2.5 in compartments with absorbers but where Line-of-sight communications are prevalent (flight deck, fuel tanks etc.)
 - 3 in compartments with absorbers and non Line-of-sight communications (cabin, cargo bay etc.)
- the most fitting **fading model** was found to be a *Rayleigh model*.
- an in depth **path loss model** is presented, with shadowing and fading taken into account and accurate path loss exponents depending on application.

The information in these reports could prove significant for all future work on Wireless avionics intra communications.



3 Antenna technology

Antennas are a crucial part of all wireless communication systems. As such, it is deemed important to include an overview of existing antenna technology. However, a full academic explanation of antenna science is beyond the scope of this document. Alternatively, focus will be given on outlining key elements of antenna technology. Specifically, the two following sub chapters deal in presenting important functional metrics and describing significant antenna types.

3.1 Fundamental parameters

An antenna is the interface between radio waves propagating through space and the electric currents moving in device electronics. It is the responsible part of the system for transforming the wave to current and vice versa (receiver/transmitter). Naturally, engineers need a way to describe this transformation and quantify its properties.

Antenna characteristics perform this role: these parameters describe the antennas operation as a gateway between radio propagation and an electrical signal. The most important properties are presented below, and are followed by a short explanation.

- **Field Strength:** (V/m) represents the strength of the electromagnetic field at equally distanced points from the antenna.^{vii} It is usually plotted as a function of direction (called a radiation pattern). It is important because it allows us to know how to direct our antenna to maximize its efficiency. An example radiation pattern is given next.
- **Gain:** (dBi) describes how strong a signal an antenna can send out (or receive) in a specified direction (usually the maximum gain/main lobe). It is defined as the power transmitted by an antenna in a specific direction in comparison to a lossless antenna radiating equal power in all directions (isotropic radiator).
- **Radiation Efficiency:** shows the percentage of the input energy that is radiated and not lost due to material imperfections. It is defined as the ratio of radiated power to the input power.
- **Bandwidth:** (Hz) is the frequency range over which we can expect the antenna to work as intended.
- **Antenna Polarization:** refers to the physical orientation of the electromagnetic wave radiated in a given direction. Polarization of an electromagnetic wave is a time varying attribute.

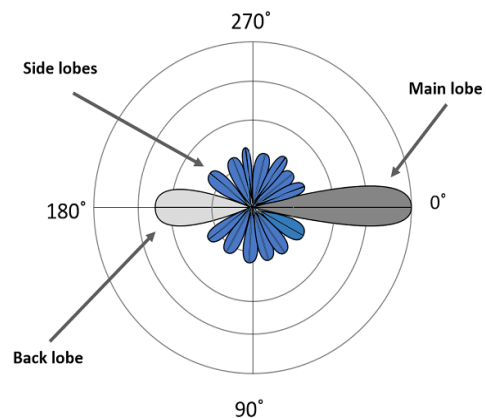

It is important to note that these attributes only consider the far field behaviour of an antenna. That means that these numbers work when the distance between the receiver and transmitter is above a certain point. This minimum distance is called the Fraunhofer distance ($d = \frac{2D^2}{\lambda}$, D is the antenna's largest dimension).

3.2 Antenna types

There are many different types of antenna technology. Each of those has a different way of working and consequently is mainly used for different applications. In this sub chapter, some elementary antenna types will be presented followed by antenna technology that is typical of similar applications to the considered one.

3.2.1 Dipole antenna

Dipole antennas and their variants are the most basic form of antenna. Typically, such an antenna consists of two conductors (usually metal rods or wires) arranged symmetrically. Alternatively, eliminating one conductor and grounding the other end of the feed line results in the monopole variant. These antennas are considered easy to make, effective and have omnidirectional radiation patterns. They are mostly used for everyday applications like radio or TV or as a basic block for more complex antenna designs. However, monopole antennas were used to make a wireless avionics feasibility test.^{viii}

3.2.2 Microstrip (patch) antenna

Patch antenna technology is a crucial part of today's communications. Essentially, an individual microstrip antenna consists of a patch of metal foil on the surface of a printed circuit board with a metal foil ground plane on the other side of the board. This results in relatively inexpensive antennas with high directional gain and small dimensions: ideal for many applications including mobile phones and aircraft antennas.

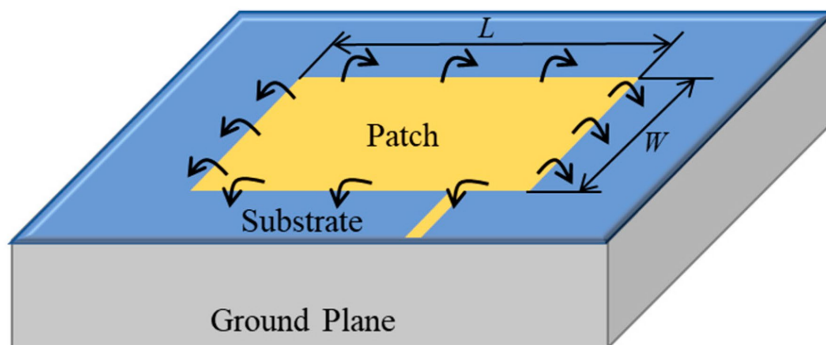

3.2.3 Antenna array

An antenna array (or array antenna) is simply a set of multiple connected antennas which work together as a single antenna (to transmit or receive radio waves). A variant of this, the phased array, is a computer-controlled array of antennas. With this technology, it is possible to electronically steer the antenna beam to point in different directions without physically moving the aperture. Such techniques allows us to achieve higher gain, increase communication reliability and to cancel interference from specific directions.

4 OSI Layer architecture

The design of a wireless system is not only the selection of a wireless standard or the inclusion of a particular set of technologies. Understanding what the system will be doing and how it will interact with its subparts is important. Furthermore, In order to deliver a system that can meet the requirements, modifications to the used technology will be necessary. These modifications include adding extra functionalities, selecting a mode of operation or providing better feedback to the user.

Moreover, it is important to keep in mind that this system will work in tandem with other communication systems. Current estimates and expectations are that future aircraft will contain a mixture of traditional wiring systems, power line communications and wireless technologies. Interoperability and common standards are key to the project's success.

In this chapter, topics that are important on the system level but not directly connected to a particular standard will be discussed. This discussion will be centered on OSI layers. The Open Systems Interconnection model (OSI model) is a conceptual model that characterizes and standardizes the communication functions of a telecommunication system. The model partitions a communication system into abstraction layers. The original version of the model has seven layers. However, wireless communications standards are define only the first two or three layers. These layers are the most important to wireless communications and thus only aspects regarding the first three will be presented. The following figure is an outline of the full OSI model.

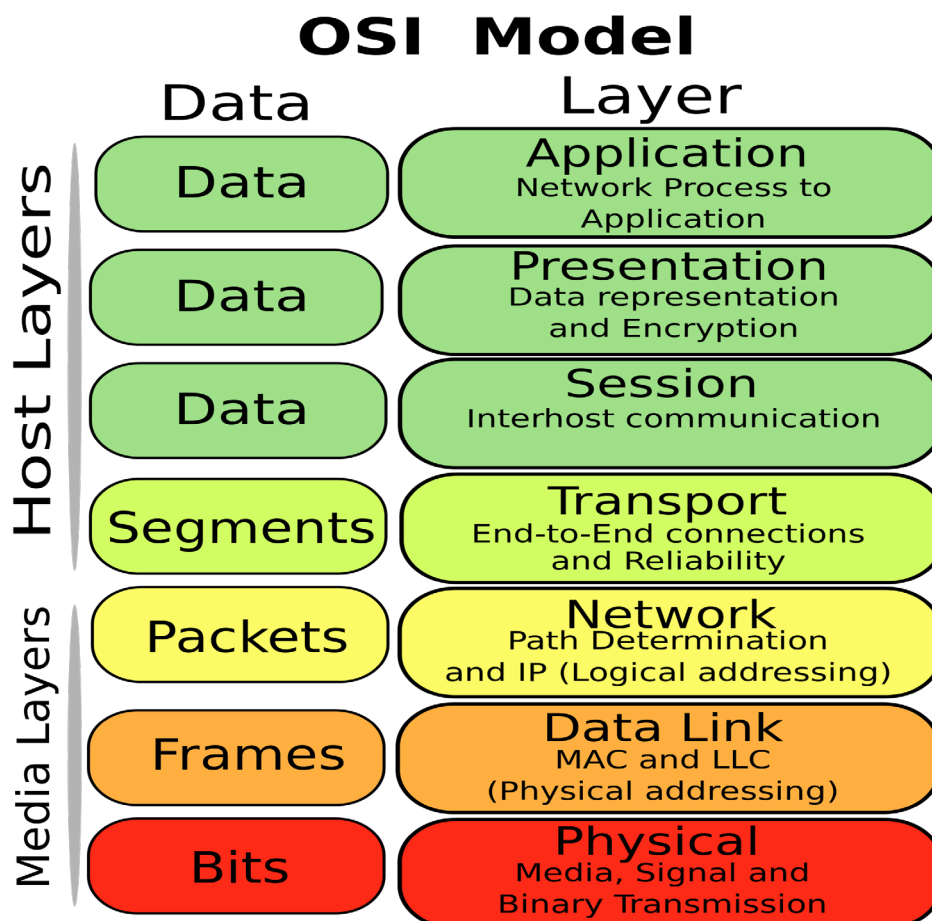

The structure of these sections is outlined below. Each section will be dedicated to a certain OSI layer and will include subjects relating to it. Specifically, in the first section (4.1) matters involving the physical layer (layer 1) will be discussed. In the second section (4.2) focus will be given to the data link layer (layer 2) followed by a short section (4.3) on the network layer (layer 3). Additionally, a section on the network management aspect of such a system will be provided in the last section (4.4).

4.1 Physical layer

The physical layer consists of the electronic circuit transmission technologies of a network. Its importance cannot be underestimated since the activities of all upper layers depend on it. The physical layer sets the limits and its design affects what the system can and can't do.

In the following sub-sections some important aspects of the wireless physical layer will be discussed.

4.1.1 Modulation techniques

Modulation affects many characteristics of the wireless link. Such characteristics are the reliability, the data rate and the power consumption. Usually, in order to increase the data rate while maintaining the same error ratio an increase in transmitted power is required. This is a typical trade-off that is made when deciding on the deployment of a modulation scheme.

Since modulation is so important to a wireless system it is crucial to know the different modulation schemes that are available. This allows for a better assessment of the strengths and weaknesses of the protocols that were introduced in chapter 4 "Wireless standards and trends". In the following paragraphs, short descriptions of the most predominant digital modulation techniques can be found.

4.1.1.1 Phase-shift keying (PSK)

The basic principle of PSK's operation is that information is encoded on the phase change of the signal. The simplest form of PSK, Binary Phase Shift Keying (BPSK), uses two opposite signal phases (e.g. 0 and 180). Each phase shift represents a bit: for example a change in phase equals to a one, and no phase change equals to a zero. Other forms include QPSK (Quadrature phase shift keying) where four phase states are used and phase shifts represent two bits and 8-PSK where there are eight states (and so forth). In practice, due to the steep increase in errors only BPSK and QPSK are used. In general, it is considered a simple to implement and robust scheme that offers limited data rates.

4.1.1.2 Quadrature amplitude modulation (QAM)

QAM modulation works by deploying two carrier signals. The carriers operate on the same frequency but differing in phase by 90 degrees (they are orthogonal to each other). The two modulated carriers are combined at the source for transmission. The resultant signal consists

of a combination of both carriers, containing both amplitude and phase variations. Specific combinations of the two carriers (amplitude and phase variations) represents a specific group of bit(s). That means that, compared to PSK it is less likely to include errors in demodulation as the different symbol states have more differences. However, this also makes the demodulation more complex, since the phase is not the only monitored parameter. For these reasons QAM is considered the modulation scheme with the highest achievable data rate and spectral efficiency. The trade-off is that QAM modulators and demodulators are complicated to make. The figure below displays the difference between 16 PSK and 16 QAM modulation.

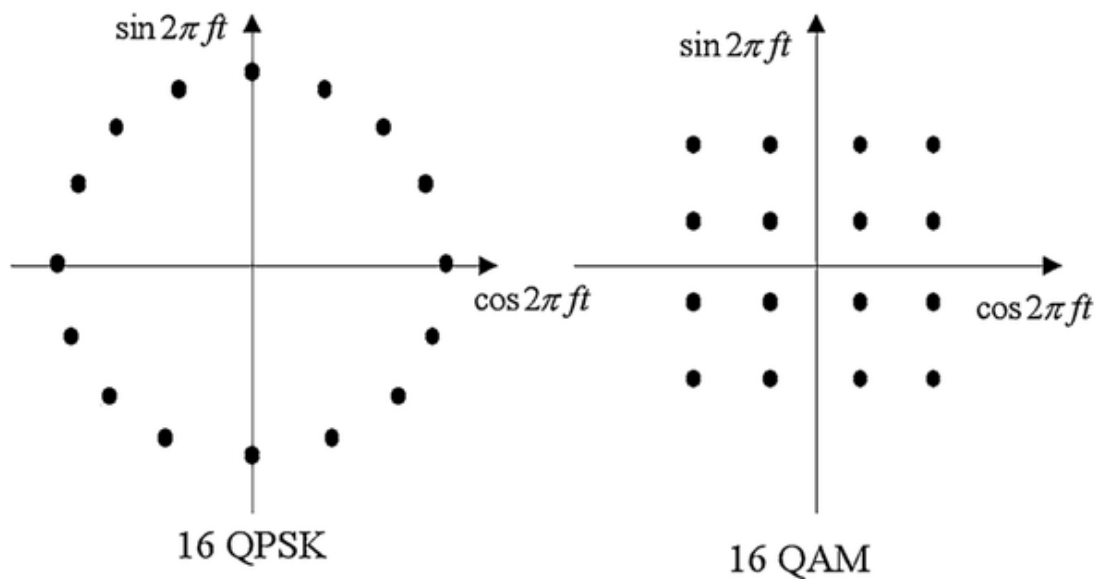

4.1.1.3 Direct-sequence spread spectrum (DSSS)

DSSS is a modulation technique used to reduce the effect of interference to a signal. Essentially, DSSS is a multiplication on the data being transmitted with a pseudorandom “spreading” sequence that has a much higher bit rate. To reconstruct the original data at the receiving end, it is only necessary to know the sequence. By multiplying the signal again with same spreading sequence, we get the original data (because $1 \times 1 = 1$, and $-1 \times -1 = 1$). This makes DSSS a technique that increases the links resistance to interference and jamming, provides some security and creates less noise to the expense of spectral efficiency (since more bandwidth is required). The following image further illustrates the DSSS technique.^{ix}

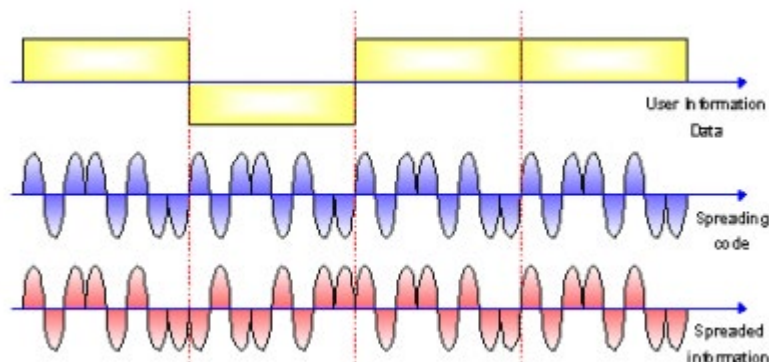

4.1.1.4 Orthogonal frequency-division multiplexing (OFDM)

As the name implies, OFDM is a version of frequency division multiplexing. That means that it uses multiple carriers to transmit a signal, each of which utilizes a different part of the available bandwidth. The key difference in OFDM is that the subcarriers are orthogonal to each other. This allows the individual demodulation of each subcarrier (provided that the transmission is linear and there is a guard interval between the transmitted symbols). With this technique it is possible to transmit different parts of the signal simultaneously making the transmission immune to certain fading types (fast and selective) and resistant to interference without sacrificing a high bit rate. Additionally, this can be accomplished with relatively simple modulators and demodulators and with high spectral efficiency (compared to DSSS). A disadvantage of OFDM is that it has relatively high average power consumption increasing the cost of the system and making it reliant on a stable power source.

4.1.2 Coding schemes

Coding is a technique used for detecting and correcting errors in transmission. The idea is that the sender encodes the message in a redundant way, adding redundant bits to the transmitted signal. The coding rate is calculated as follows: if n bits are transmitted for every x actual bits of information ($n > x$) the coding rate is x/n . Adding more redundant bits (making n bigger than x) is a trade-off between effective bit-rate and reliability. Usually, such a technique is employed when the channel is lossy and a re-transmission must be avoided (power or time constraints are the main reasons).

4.1.3 Link adaptation

Link adaptation, commonly referred to as adaptive coding and modulation, is a technique employed in wireless systems whose links display a time-changing behaviour. The core principle of this technique is that the system should have a combination of coding and modulation schemes that takes full advantage of its wireless channel. Specifically, if the conditions are good, higher order of modulation is employed (QPSK to 16-QAM etc.) and combined with a simpler coding scheme (or not coding at all). Conversely, if the system detects a drop in link quality, stricter protocols are used. The benefit to link adaptation is that a high bit rate is maintained while overall system reliability is not sacrificed. In order for this method to be applicable however, it is necessary to add a new function to the system: channel assessment.

4.2 Data link layer

The data link layer or the medium access control layer, is responsible for arbitrating access to the shared medium. Furthermore, the MAC layer's mission includes resolving any potential conflict between the nodes and correcting errors from the physical layer. The choice of MAC protocol has a direct impact on the reliability and efficiency of network transmissions.

There are many difficulties that can be encountered in the design of a wireless system's MAC layer. Important examples include the asymmetrical nature of the links, the time varying nature of the channel and the difficulty of transmitting and receiving at the same time. Commonly, these problems lead to specific requirement criteria: a MAC layer is well designed

if it allows for high throughput, has little overhead and efficiently handles available resources (bandwidth, time and power).

However, there are significant differences in the wireless aircraft intra communications case. Reliability and adaptability are very important system attributes and that needs to be taken into account. Furthermore, depending on the application, there are significant power restrictions. For this reason, it is consider necessary to be aware of the various MAC layer technologies and to understand the potential trade-offs that can be made.

In this section, various MAC layer design philosophies will be discussed. In the first sub-section (5.2.1) contention-based protocols will be analyzed and some relevant examples will be provided. Next, in sub-section (5.2.2) contention-free protocols will be presented.

4.2.1 Contention-based protocols

The core principle of any contention-based protocol is that nodes in the network transmit packets at any time, without explicit permission. This makes contention-based protocols very easy to implement and relatively fast since only the minimum delay is added to the transmission time. However, when two nodes try to simultaneously transmit the result is packet drops, also called collisions. This makes such protocols unpredictable and non-deterministic. In general, they are considered a good fit for a system that should expect light traffic or when simpler nodes and end devices are preferred. The most typical contention-based protocol are presented below.

- **Aloha**: This is the simplest protocol, where nodes immediately send data packets and wait for an acknowledgment to confirm correct reception. This is the easiest to implement but the highest congestion rate.
- **CSMA** (Carrier Sense Multiple Access): In CSMA, a node first senses the channel before attempting to transmit. If the channel is free then the nodes relays its message. If it is not, or if the message gets interrupted, the node performs a back-off operation and tries again (depending on the deployed algorithm). This is the most used protocol as it incurs minimum overhead while significantly decreasing errors.
- **MACA** (Multiple Access with Collision Avoidance): The process of the MACA protocol is similar to CSMA. The difference is that after a node senses a free medium, it sends a message asking for permission to transmit. It begins transmission only after receiving a clear to send message. The benefit is that now collision frequency is further reduced while protocol overhead is increased.

4.2.2 Contention-free protocols

In contention-free protocols, each node can use only its own allocated resources to transmit a message. This is typically defined by a central node though this is not always the case. This resources can be time (Time Division Multiple Access), frequency (Frequency Division Multiple Access) and code (Code Division Multiple Access) or a combination of any of the above. Contention-free protocols have the advantage that can be predictable and allow for deterministic systems. Conversely, fixed assignment usually leads to inefficiently handling of the available resources. Below the above mentioned strategies will be briefly presented.

- **TDMA:** In TDMA, every node gets its own time slot where transmission is allowed. Usually, a master node or server node is responsible for the network schedule and for keeping the other nodes informed on it. This architecture allows the nodes to sleep or switch-off when they are not expecting to transmit or receive any packet resulting in important power savings. Most wireless communication networks employ some form of TDMA.
- **FDMA:** In FDMA, the nodes instead get their own frequency slot. Since this frequency is reserved for their use, it is possible for many nodes to transmit simultaneously while not increasing interference levels. In modern wireless communication system, this is typically achieved with OFDM modulation, a technique named Orthogonal Frequency Division Multiple Access (OFDMA). This allows each node to dynamically be assigned a frequency band, depending on the application's needs. This is further illustrated on the following figure.

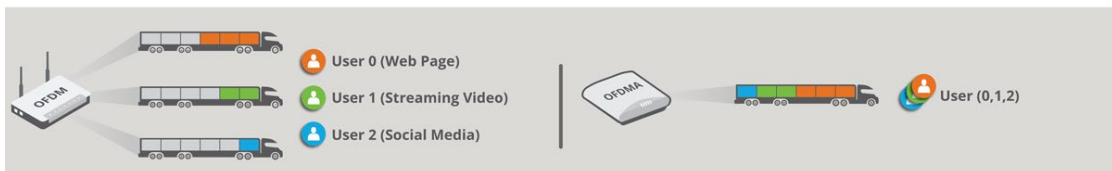
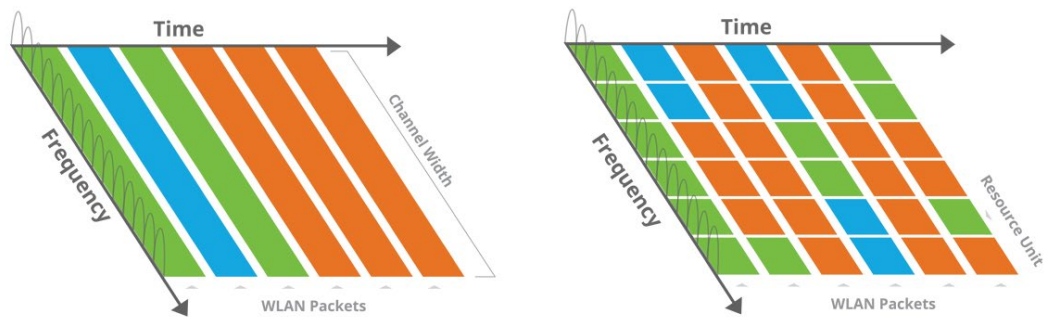

- **CDMA:** In CDMA, each node gets a specific code. In order to transmit, this code is first combined with the original signal. Then, the receiver by using the appropriate code can recover the original node's message. While theoretically this allows for simultaneous transmissions without sacrificing bandwidth or increasing the latency in practice it is not often preferred because it requires fairly complex nodes.

4.3 Network layer

The network layer is responsible for forwarding the packets to their destination, usually including routing through intermediate points (gateways, routers etc.). In wireless systems in particular, the key difference resides in the links. A node in a wired system usually either has or doesn't have a connection with another node, while in wireless systems this is more complicated. Issues like the time-varying behaviour of the channel, the power requirements to transmit to a faraway node or node mobility should be taken into account. For this reason, many protocols have been proposed to make sure that the system will function properly.

The primary focus of such protocols, is network hierarchy. Having different classes of nodes helps in addressing and consequently routing^x. Furthermore, it has direct implications on the intelligence distribution of a communications system. A common approach is to assign the role of a cluster head to a central node. In this case, all traffic to and from the network is first forwarded to the cluster head and then directed to the appropriate node(s). Examples of deployed architectures can be seen in the figure on the right.

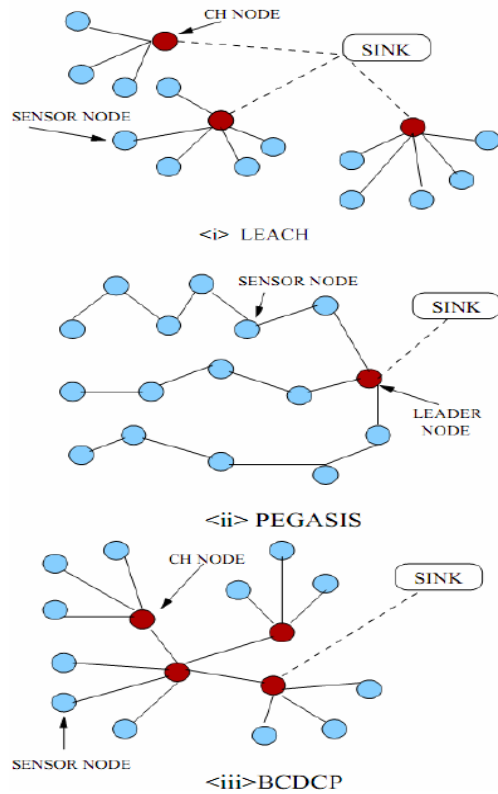

Nonetheless, the network layer in a wireless aircraft intra communication scenario is not substantially affected by the wireless aspect of the system. Due to the envisaged architecture and combination of different technologies, only the front end of the system is expected to be wireless. In detail, it is expected that nodes will wirelessly relay information to a central node who in turn will be connected to the avionic data network via a wired connection (traditional bus or power-line communications). In that sense, the network layer is beyond the scope of this document and will not be further discussed, as it deals with the wired part of the aircraft data system.

Usually, this is the last point in the OSI layer where a wireless system has a significant difference with any other communication system. As the scope of this document is to give insight in potential wireless systems, other OSI layers fall beyond of the projects interests and thus will not be further discussed.

4.4 Network management

Network management is the process of administering and managing communication networks. Traditionally, this includes fault analysis, performance management, setting or changing network configurations and maintaining quality of service. In order to achieve that, collaboration between all the OSI layers is imperative, as each of those is important to properly manage the network.

In particular, in the wireless aircraft intra communications case, network management is an essential piece to the system's successful operation. Since interoperability and scalability are important parameters the system needs to be flexible and support changes towards those directions. Additionally, fault analysis and correction is also more important than usual since it helps troubleshooting and repairing potentially life-threatening faults. For those reasons, it is important to provide the necessary tools to the network manager.

In conclusion, this mean that when choosing between competing technologies it is important to favor versatile options. This will help the overall goal of the project and increase system reliability and efficiency. Link adaptation and dynamic MAC designs are good examples of this.

5 Wireless technologies and standards

Wireless technologies have no significant presence in aircraft intra communications as of now. That means that there is no universally accepted standard or technology. Since the applied standard is very important regarding the capabilities of a wireless system, it is crucial to select a technology that results in a system that can meet all the requirements.

However, in order to be able to make a decision we should first have a clear understanding of the state-of-the-art of relevant wireless technology. In this chapter, any wireless technology that could play a role in our project will be presented. In the first section (5.1) the standards proposed by WAIC will be discussed. Then, a section (5.2) on IEEE 802.11 (Wi-Fi) variants will be presented followed by a section (5.3) on Industrial Internet of Things technologies and a section (5.4) on relevant cellular technology. Lastly, a section (5.5) on new and innovative tools will be provided.

5.1 WAIC proposed standards

WAIC, as introduced in report D1 on aircraft industry ambitions and roadmaps is a consortium that has been campaigning for standardization and adoption of wireless technologies for aircraft intercommunications. During their activities (collaboration with ITU-R^{vi}, and self-organized workshops^{xi} among others) in order present technical characteristics they suggested two wireless standards as potential baselines. These are 802.11a/g (a Wi-Fi variant) and 802.15.4 (the basis of ZigBee).

Specifically, WAIC suggests selecting a standard based on the type of the envisioned application. Based on ITU-R's reports, there are four such types: **low data rate inside**, **low data rate outside**, **high data rate inside** and **high data rate outside** (*low/high means that the data rate per link is expected to be less/more than 10kbit/s*) (*inside/outside means that the application area will be wholly inside/outside the fuselage*). WAIC came to the conclusion that a 802.15.4 variant will be a good fit to low rate applications' requirements while a 802.11 a/g based technology should cover a high rate application's needs.

In the following subsections, these standard suggestions will be further analysed.

5.1.1 802.11 a/g variant

802.11 g is the third amendment to the original Wi-Fi standard. Last updated on 2012, this technology specifies the physical layer and the data link layer implementation (up to layer 2) of wireless local area networks.

An important feature of 802.11 a/g is that it provides a flexible physical layer design. In particular, eight modes of function are offered: each one has a different data rate. In order to support higher data rates however, more complicated modulation schemes are employed. This means an increase in the necessary SNR, and a system more prone to errors. In total, these modes represent a trade-off between desired data rates and system resilience.

Acknowledging this, WAIC made an analysis on the selections of the physical mode. They calculated the maximum power that a WAIC system can transmit and assumed the worst case

scenario in terms of noise. Based on this, they suggested physical mode 3. In the next table, key technical details of the proposed physical mode are presented.

| Parameter | Parameter Value |
|---|-----------------|
| Channel bandwidth (4 channels simultaneously) | 20 MHz |
| Data rate | 12 Mbps |
| Modulation | OFDM / QPSK |
| Required SNR | 14 dB |

This results in a **relatively low power, reliable and efficient system**. OFDM reduces the impact of multipath effects and increases spectral efficiency. The resulting speed is deemed sufficient for most potential high data rate avionic applications. The protocol is deemed relatively secure and is efficiently using the available spectrum. However, this suggestion is dated and since then, other 802.11 variants have become available. These will be discussed in later sections.

As a side note, it is worth mentioning that this protocol wasn't made with the WAIC band in mind (4.2 GHz – 4.4 GHz). However, provided that a suitable antenna can be provided, that doesn't seem to be a problem. Some researchers ^{viii} resorted to crafting their own antenna in order to test a wireless avionics system with this particular protocol.

5.1.2 802.15.4 variant

802.15.4 is a technical standard which defines the operation of low-rate wireless personal area networks (PAN). Introduced in 2003 this standard again only specifies the physical layer and the data link layer. It belongs in the broader family of 802.15 which includes other well-known protocols such as Bluetooth (802.15.1). Specifically, 802.15.4 has been a basis for many higher stack standards such as ZigBee 6LoWPAN and 6TiSCH.

This protocol is mostly known for being an extremely low power and low cost answer with a reliable and low throughput. There are many mechanisms employed to ensure this. 802.15.4 nodes remain active as little as possible in order to preserve energy. Additionally, it supports a configurable medium access mechanism. Specifically, messages can be transmitted with a contention based mechanism in low traffic or with a guaranteed slot in high traffic scenarios.

Naturally, all of these functions significantly impact the overhead of the protocol. That means that 802.15.4 has low spectral efficiency. In the following table, key protocol characteristics are presented.

| Parameter | Parameter Value |
|---------------------------------|-----------------|
| Channel bandwidth (16 channels) | 5 MHz |
| Data rate | 250 kbps |
| Modulation | DSSS / O-QPSK |
| Required SNR | 4 dB |

This results in a very low power and reliable system. The resulting speed is considered more than sufficient for all potential low data rate aircraft applications. Moreover, the low energy demand seems to support an energy harvesting or passive system. The protocol is again deemed relatively secure and is expected to consistently display reliable behaviour. Further developments have been made to that direction since the initial suggestion by WAIC. These are further discussed in next sections (Industrial Internet of Things technologies).

As a side note, it is worth mentioning that this protocol was also not made with the WAIC band in mind (4.2 GHz – 4.4 GHz). As with the 802.11 a/g case though, this should not be an issue if we can design a suitable antenna.

5.2 IEEE 802.11 variants

Apart from the Wi-Fi a/g that was suggested by WAIC, multiple variants interesting for the wireless intra communications case have been released. Namely, 802.11 ac, 802.11 ad and the latest specification 802.11 ax have interesting properties and should be considered as potential candidates. In this section, these IEEE 802.11 variants will be discussed.

5.2.1 802.11 ac

This protocol is an improvement on the legacy protocol. Introduced in 2013 and later updated in 2016, this variant has significantly increased bit rate. This is achieved by wide channels centered in the 5 GHz band, higher-order modulation and the addition of Multi-user Multiple Input Multiple Output technology (MU-MIMO). In addition, multiple physical modes are supported, as the previous variants. Below, key information is presented in a table format.

| Parameter | Parameter Value |
|---------------------------------|--------------------------------------|
| Channel bandwidth (16 channels) | 20 - 160 MHz |
| Data rates supported | 6.5 - 3500 Mbps |
| Modulation schemes supported | OFDMA / BPSK, QPSK, 16-QAM – 256-QAM |
| Required SNR | 5 - 40 dB |

While the protocol's bit rates are high, it has some deficiencies like increased power consumption. 802.11 ax, a variant that was later introduced is a direct improvement of 802.11 ac and will be further analysed in a later subsection.

5.2.2 802.11 ad

802.11 ad is a variant that results in a very high bit rate protocol. This is achieved by utilizing the 60 GHz millimetre wave spectrum. This frequency band has significantly different propagation characteristics than the 2.4 GHz and 5 GHz bands where Wi-Fi networks typically operate. However, in comparison with all other standards that are presented in this chapter, it is significantly lacking in effective range (1-10 meters). For this reason, it is not suggested to base a wireless intra communications system on this protocol, and thus it will not be further discussed.

5.2.3 802.11 ax

This variant introduces major updates to the legacy protocol. Specifically, the new version includes methods to limit interference, increase throughput and spectral efficiency as well as decrease power consumption. Additionally, as per previous versions, it supports many different physical layer modes. However, the modes are not only a trade-off between higher data rates and a higher order modulation and coding scheme: it is also possible to increase channel bandwidth. Nonetheless, it is yet unclear what of those modes is going to be the best fit for our project. Similarly to the ITU-R report on 802.11 a/g, it is necessary to first analyse

the various modes and their impact on system reliability. The next table presents the already known information.

| Parameter | Parameter Value |
|---------------------------------|---------------------------------------|
| Channel bandwidth (16 channels) | 20 - 160 MHz |
| Data rates supported | 8 - 1200 Mbps |
| Modulation schemes supported | OFDMA / BPSK, QPSK, 16-QAM – 1024-QAM |
| Required SNR | 5 - 40 dB |

In total, the protocol seems to be fairly robust and offers very high data rates while having high spectral efficiency and reliability. As a trade-off, it demands higher power consumption and a significant investment in resources as the technology is neither widely deployed nor tested yet. Based on this information, it seems that this protocol could be a suitable candidate for high data rate wireless intra communication applications. It has the potential to replace the backbone of the data network, possibly even acting as a wireless AFDX in smaller aircraft. It is worth mentioning that researchers and industrial experts are considering the benefits of adopting this technology in the automotive industry^{xii}.

Finally, this protocol is designed to work on the 2.4 and 5 GHz bands, while there are plans for expanding the supported frequencies. That could positively affect any wireless avionic intra communication application based on this protocol.

5.3 Industrial Internet of Things technologies

Apart from consumer applications, internet of things technologies are starting to be used in industrial settings. Specifically, companies and manufacturers think that having a centralized way of managing and controlling their assets is the logical next step to their activities.

Part of this trend is installing wireless sensor and actuator networks or replacing already existing wiring with wireless systems. Such a deployment however, requires reliable and robust technologies. This is a very strict requirement, because apart from the increase in operational costs, a system malfunction is sometimes attributed to risk of human health in an industrial setting. Additionally, low energy consumption and high security are attributes that are being prioritized.

All this makes the comparison to wireless aircraft intra communications clear. The motivation and the requirements are strikingly similar. For this reason, it is deemed important to investigate the protocols that are being used for wireless industrial internet of things applications. The two most significant cases are presented in the next sub-sections.

5.3.1 Time Slotted Channel Hopping

Time Slotted Channel Hopping (TSCH) is channel access method (layer 2). It is made with low power devices in mind that have to operate in a lossy network (lots of interference etc.).

TSCH can be seen as a combination of Time division multiple access and Frequency-division multiple access mechanisms as it uses diversity in time and frequency to provide reliability. In essence, it creates slots for each possible time-frequency combination. (An example of such a table can be found below). Additionally, TSCH also keeps track of channel quality: if a channel is consistently dropping packets it is blacklisted.

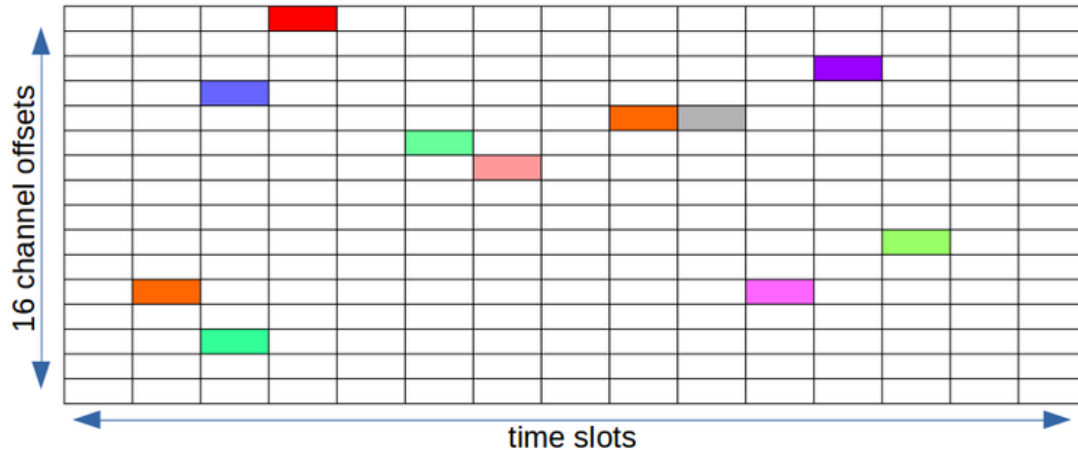

TSCH, as of 2015, is included in the latest version of 802.15.4. Additionally, ISA100.11a (International Society of Automation) is implementing a similar layer 2 method.

5.3.2 6LoWPAN

6LoWPAN (IPv6 over Low - Power Wireless Personal Area Networks) is a full-stack protocol based on the bottom layers specified in 802.15.4. As the name implies, it allows IPv6 messages to be transmitted and received from a low power network. 6LoWPAN is considered to be beyond the scope of this document, since it is unclear what would be the benefit for wireless aircraft intra communications in adopting a system based on IPv6.

5.4 Cellular technologies

In cellular communications, the covered area is divided in “cells”. Each cell is supported by a broadcasting radio station. This station acts as a gateway to an entire communication network, giving access to any device connected with it. The connected devices can communicate with any other device in the network sharing voices, data or video. In principle, cellular technologies don’t seem to be interesting to our case since they require significant infrastructure which is not practical in an aircraft setting.

However, cellular technologies are the basis of all wireless communication. Many innovations and breakthroughs are first used for the new generation of cellular technologies and then are adapted to other standards. Furthermore, since these technologies have lots of potential and are still being deployed, it is possible that the concept of multiple pico-cells connected to a base station is considered for future aircraft. For those reasons, it is deemed important to include the latest generation of cellular communications technology in this report.

5.4.1 5G New Radio

5G is the fifth generation wireless technology for digital cellular networks. It combines an assortment of many new technologies and promises spectacular performance. The ITU-R has defined three main uses for 5G. They are Enhanced Mobile Broadband (eMBB), Ultra Reliable Low Latency Communications (URLLC), and Massive Machine Type Communications (mMTC). The first is already deployed, while the other two are still under development. The basic three different directions and some characteristic use cases are presented in a more clear fashion below.

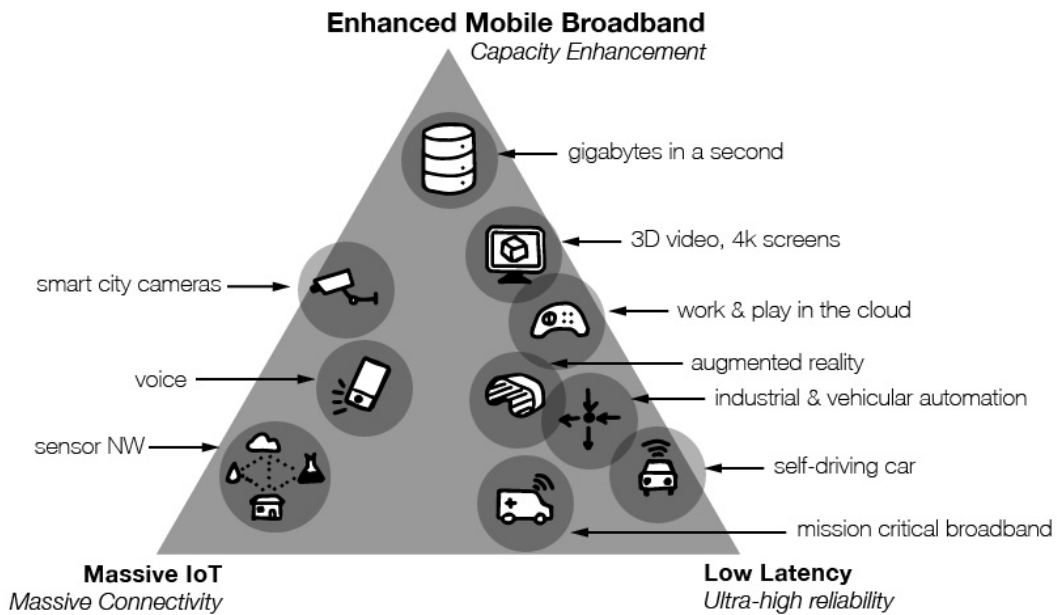

Out of these directions, “Low Latency Communications” seems to be a very good fit to a potential wireless aircraft intra communications application. This is further illustrated by the examples that are being suggested in this area like “industrial & vehicular automation”: a case that as already established in the previous section is similar to our project.

In order to better understand what 5G offers, it is important to study its specifications. The following table includes some key numbers promised by 5G technology.

| Parameter | Parameter Value |
|---------------------|-----------------|
| Peak data rate | 20 Gbit/s |
| Minimum latency | 1 ms |
| Required power | 10% of 4G |
| Spectrum efficiency | 4X of 4G |

This result is the product of the combination of many different technologies. In detail, 5G employs the following wireless technologies:

- Massive MIMO (Multiple input multiple output) up to hundreds of antennas
- Network slicing
- Software defined networking
- Beamforming and adaptable power consumption
- Millimetre wave frequency (24 GHz) and other frequencies (3.5 GHz)

It is important to note that one of these technologies, the millimetre wave frequencies are very difficult to implement in an aircraft. Additionally, most of the other offered functionalities do not significantly benefit our project. In total, this means that in order to use 5G in a wireless aircraft intra communication system significant modifications would have to be made. In the future, this could have important benefits to our project.

5.5 Emerging technologies

Apart from the already described protocols, there are some technologies that are currently being deployed or developed, yet are significantly promising. Such trends could prove to be important to wireless aircraft intra communications. At the very least, it is important to know where the technology is heading in order to be able to anticipate future updates and possibilities. The next following sub-sections will briefly present some such important communication trends.

5.5.1 Cognitive radio

The ambition of cognitive radio technology is the creation of a self-reconfigurable wireless transceiver which automatically adapts its communication parameters to network and user demands. This radio system can be configured dynamically to use the best wireless channels in its vicinity. Such a radio automatically detects available channels in wireless spectrum, then accordingly changes its parameters. Apart from operating frequency, these parameters can even include changes in modulation schemes and protocol use. The purpose of this dynamic spectrum management is to waste as little resources as possible. Spectrum, energy usage is minimized and interference and congestion are mitigated and avoided.

Such a technology could greatly assist a wireless aircraft intra communication network. Power and bandwidth are scarce in aviation communications making efficient use of them critical. However, it is important to have clear understanding of the projects requirements: reliability is essential. The projects first priority should be a robust network infrastructure. Updating this infrastructure in the future with cognitive radio technology however is an idea that will have to be investigated more in the future.

5.5.2 Optical wireless communication technologies

Apart from RF signals, optical communications are another approach to wireless communication. Optical technologies have important benefits. They are easy to deploy, they don't need regulation and are harder to intercept and jam. However, they depend on line-of-sight and are very sensitive to environmental factors. Such technology is only reliable when the communication link is short and clear of obstructions.

Significant examples include Li-Fi which is under development for aircraft entertainment networks^{xiii} and surface wave technology which is still on the research phase^{xiv}. Since these technologies do not currently offer promising alternatives for the development of a wireless intra communication network, they will not be discussed further.

6 Security

In aviation technology, security is a prime concern. All the subsystems are made to be compliant to very hard regulation and guarantee the safe operation of the aircraft. The aircraft data network, a subsystem of the aircraft itself, is designed with the same principle. In its design, several assumptions are made to simplify the network. Arguably, the most important assumption is that a potential attacker is unable to access the network.

However, in the case of a wireless aircraft intra communication system, this assumption can't be safely made. The wireless channel is accessible to anyone who has proper equipment and knows the operating frequency. Since such equipment is easily accessible, it is important to take precautionary measures. For the project's success, it is important to ensure that a wireless system provides, at a minimum, equivalent levels of safety to those offered by the wired network.

In this chapter, a brief analysis on the security of a wireless system will be presented. In the first section (6.1) the security challenges will be highlighted while in the following section (6.2) potential solutions and protocols will be investigated.

6.1 Security challenges

As was previously established, a wireless aircraft intra communication network will need to be reliable, safe and resistant to malevolent attacks. For this reason, it is important that based on the experience of terrestrial wireless networks, potential security threats and angles of attack are identified. In this section, focus will be given on outlining the anticipated methods of compromising the security of our network. Specifically, in the first subsection (6.1.1) the threat model will be specified while in the next subsection (6.1.2) expected forms of attack will be presented.

6.1.1 Threat model

In order to efficiently secure our system, it is important to understand the capabilities of a potential attacker. Assumptions on what the malevolent party can't or can do are of crucial importance, since they allow for a design that appropriately deals with the threat.

Specifically, the important factor is the attacking party's resources. Such resources, can be time, technical knowledge, financial support and computing power. Based on relevant literature^{xv} and past experience, the capabilities of the malevolent party are expected to be as follows:

- Has the means to monitor any wireless link and receive any transmitted packets.
- Has the means to send signals to some of the wireless links.
- Has knowledge of the network architecture and employed protocols and devices.
- Has access to more computational resources than the network nodes.
- Has a limited time window to perform an attack (flight duration).
- Does not have physical access to any node in operation or other flight sensitive control panels.

6.1.2 Types of cyber attack

Apart from understanding the capabilities and limitations of potential attackers, it is important to know the methods that they typically employ. Potential attack philosophies that have to be taken into account are presented in the following paragraphs.

6.1.2.1 Spoofing

Spoofing refers to all kind of cyber-attacks that attempt to make the network falsely recognize a node controlled by an attacker as a node that is part of the network. To achieve this, many methods can be employed. Common methods are ARP spoofing where the attacker tries to associate the MAC address of his device to the IP address of a node in operation, and the MAC spoofing where the attacker changes the MAC address of his device to the MAC address of a node in operation. Similar results can be achieved with the replay attack variant, where the attacker replays back an intercepted message. This method represents a threat, since having access to a part of the network means that the integrity of the whole system is exposed.

6.1.2.2 Denial of Service (DoS)

In this attack, the attacker attempts to overcome the limits of either the communication channel or the computational capability of the target node. This can be done by flooding the network with any kind of message. This can result in significant packet drops and affect system availability.

6.1.2.3 Jamming

Jamming attacks are notoriously difficult for wireless systems to handle. In this kind of attack, the attacker attempts to disrupt wireless communication by broadcasting a signal with high power in the used frequency bands. This can have detrimental effect to a wireless network and render it completely inoperable for some amount of time.

6.2 Security suggestions

It is clear that security should play an important role to the design of a wireless aircraft intra communication system. Having identified the potential threats and the resources potentially available to a malevolent party, it should be possible to design a system equipped to efficiently handle any cyber threat that will arise.

In this section, the principles that a system should be designed in order to handle such threats will be discussed. In the first subsection (6.2.1) the optimal security trade-off will be discussed. Then, in the next subsection (6.2.2) the CIA triad will be presented. Finally, at the last subsection (6.2.3) some key principles for a secure system will be highlighted.

6.2.1 Optimal security measures

It should be noted that there can be no system that can be completely immune to all forms of cyber-attack. Furthermore, emphasizing too much on security can increase the overhead of the whole system and make it less effective. It is crucial to find the right balance and design a well-rounded system.

It is generally agreed, that a good compromise is to take enough defensive measures to make attacking the network not appealing. For instance, if the attacker would spend more resources in attempting to overpower the network's defenses than the value he would get from succeeding, then he is discouraged from doing so. The same principle can be applied if more traditional sources of attack and disruption are considered: if they are less or equally difficult to attempt, then the design is successful.

In conclusion, it is not optimal to install the strongest security protocols. Such an implementation might hamper the efficiency of the system without substantially increasing overall system security. It is important to carefully consider the trade-offs that will occur in the design process.

6.2.2 Core principles of a security system

The core idea of modern security systems lies in the confidentiality, integrity and availability, commonly known as the CIA triad^{xvi}. These three values are key, and should be the main focus in the design of a secure wireless system. In particular, these attributes refer to the system's ability to make information available only to authorized entities (confidentiality), to secure its accuracy and that it is not corrupted (integrity) and to make its services available when needed (availability). It is important to keep a balance between those qualities when designing the security measures.



6.2.3 Key principles for a secure system

It is clear that our system should aim to achieve an efficient defense and to adhere to core principles of security. In order to fulfill this mission, a particular set of technologies and protocols should apply. The purpose of this document is not to offer complete solutions to the security design of the project. However, it is deemed important for the sake of consistency to include significant security technologies and features. Below, a list of such potential tools that follow the principles presented in these document, can be found along with an explanation on how they will be helpful.

- Node authentication: whenever two nodes establish communication with each other, it is important that there is an authentication mechanism in place. This helps prevent spoofing attacks and requires little of the network's resources.
- Node validation: all network nodes and system administrators should be able to interrogate any node to ensure its trustworthy and proper function. This will let the operators to detect an attack early, increasing confidentiality and availability.
- Session key: at the beginning of every flight, it is important that a unique session ID key is generated for each communication link (logical or physical). This will help make most method of attack pointless and significantly increase confidentiality.
- Dissimilar redundancy: for life critical tasks, it is important not to rely on a communication link. Having traditional wiring mechanisms as backup or having alternative frequency bands might effectively counter the biggest threat: jamming.
- Fall back mechanism: in case of important malfunction or a successful attack, it should be possible for nodes to retain some functionality. Having a backup mechanism that allows them to perform limited tasks will help system availability.
- Cryptography: considering power and bit rate constraints, it is important to have an efficient cryptographic algorithm. In particular, since a flight last at most 18 hours any algorithm that requires more than that in a high end machine is sufficient.
- Frequency hopping: it is deemed potentially important to select a protocol that offers this functionality to further boost the system's resistant to a jamming attack and sustain high availability.
- Nodes location: guaranteeing that only flight personnel can access the wireless nodes is important. As outlined in previous sections, this is an assumption that was made for the purposes of this report.
- Access control: controlling who has access to what level of the network and creating a hierarchy of clearance is important for security and the proper maintenance of the network. This will also increase the accountability of the system.

7 Conclusions

The design of an aircraft's intra communications system is a complex process. Many and competing requirements must be met and to that purpose different technologies are deployed. Similarly, conventional intra communication technology is expected to be integrated along other, disruptive technologies. There is an opportunity in making the aircraft's data network lighter and more efficient.

To this direction, the adoption of wireless communications has been proposed. Wireless networks could help improve the quality and efficiency of intra communications networks while decreasing operating costs. Such improvements help make the modern aircraft more sustainable. This has many ramifications on the design of future electrical interconnection systems.

In order for such an application to work however, it is crucial that clear understanding of the state-of-the art of wireless technology is obtained. This will help directing the project and making the correct decisions. Important insights from this analysis are presented below.

The key elements in the design of a wireless interconnection system are the wireless channel, antenna technology, the existing protocols and standards and the security considerations.

For the wireless channel, a sufficient level of understanding is achieved. The propagation characteristics can be anticipated and relevant research seems to support this. Furthermore, ITU-R has provided any interested party with guidelines on the aircraft propagation characteristics. With this information, it is possible to at least perform the necessary simulations and prototype development for the success of the project.

For antenna technology, potentially interesting antenna categories have been identified. These are dipole antennas, patch antennas and array antennas. All of those are potential hardware options for this project and some have already been used in testing.

For the existing protocols and standards, there is an abundant selection of technologies. Unfortunately, it is hard to find a one-size-fits-all solution. Every alternative has its own downsides and upsides. That means that in order to pick a technology, a specific use case or application needs to be considered. All the relevant technologies will be evaluated against important criteria in the next section.

For the security considerations, a design guideline has been formulated. Understanding potential threats like improper access mechanisms and jamming attacks should be coupled with clear and achievable targets like confidentiality, availability and integrity. Several methods have been proposed to that direction.

In total, wireless technology is mature for the purposes of our project. It is possible to at least create a product that can have the most important functionalities. Focus should be put on making the correct trade-offs between the offered technologies.

8 Recommendations

The findings of this report are summarized in the Pugh matrix below.

| Alternatives | Baseline | Data rate | Reliability | Bandwidth | Power | Latency | Cost | Adaptability | Electromagnetic noise | Totals | Rank | |
|-----------------|----------|-----------|-------------|-----------|-------|---------|------|--------------|-----------------------|--------|------|---|
| 802.11 g | ▲ 0 | ○ 0 | ○ 0 | ○ 0 | ○ 0 | ○ 0 | ○ 0 | ▼ -1 | ▲ -1 | 1 | 0 | 4 |
| 802.15.4 (TSCH) | ○ 0 | ▼ -1 | ▲ 1 | ▲ 1 | ▲ 1 | ○ 1 | ▲ 0 | ▲ 1 | ▲ 1 | 1 | 5 | 1 |
| 802.11 ac | ○ 0 | ▲ 1 | ○ 0 | ▼ -1 | ▼ -1 | ○ -1 | ○ 0 | ▼ -1 | ○ 0 | 0 | -2 | 6 |
| 802.11 ax | ○ 0 | ▲ 1 | ○ 0 | ○ 0 | ○ 0 | ▲ 1 | ▼ -1 | ○ 0 | ○ 0 | 0 | 1 | 3 |
| Li-Fi | ○ 0 | ▲ 1 | ▼ -1 | ▲ 1 | ▲ 1 | ▼ -1 | ○ -1 | ○ 0 | ▲ 0 | 1 | 2 | 2 |
| 5G | ○ 0 | ▲ 1 | ▲ 1 | ▼ -1 | ▼ -1 | ▲ -1 | ▼ -1 | ▲ -1 | ▼ -1 | -1 | 0 | 4 |

Based on the table, it seems that a 802.15.4 based application is the logical place to start. If the envisaged application does not require a significant bit rate, such a standard would cover all of the projects requirements.

Alternatively, if the bit rate is important there are two dominant options. For tasks of no criticality (infotainment etc.) a Li-Fi system seems to be a good solution. For tasks where important data will be handled and the bit rate must be relatively high 802.11 ax seems to provide the best results.

This table is not the product of experiments or measurements. It is based on the understanding of the underlying technology and on the applications of the aforementioned standards. The information provided should be enough to allow for a better judgement of the available wireless technology. This table can be used as a basis for the development of a project prototype.

9 Literature and sources

ⁱ https://en.wikipedia.org/wiki/Faraday_cage

ⁱⁱ H. Saghir, C. Nerquizian, J. J. Laurin and F. Moupfouma, "In-Cabin Wideband Channel Characterization for WAIC Systems," in *IEEE Transactions on Aerospace and Electronic Systems*, vol. 50, no. 1, pp. 516-529, January 2014, doi: 10.1109/TAES.2013.120089

ⁱⁱⁱ Carl James Debono, Reuben A. Farrugia and Keith Chetcuti (January 1st 2010). *Modelling of the Wireless Propagation Characteristics inside Aircraft*, Aerospace Technologies Advancements, Thawar T. Arif, IntechOpen, DOI: 10.5772/7033

^{iv} *Propagation Measurements Inside B737 Aircraft for In-Cabin Wireless Networks*

^v Report ITU-R M.2197 (11/2010) Technical characteristics and operational objectives for wireless avionics intra-communications (WAIC)

^{vi} Report ITU-R M.2283-0(12/2013) Technical characteristics and spectrum requirements of Wireless Avionics Intra-Communications systems to support their safe operation

^{vii} Balanis, C.A. *Antenna theory: A review*. Proc. IEEE 1992, 80, 7–23.

^{viii} Bang, Inkyu & Nam, Hyunwoo & Chang, Woohyuk & Kim, Taehoon & Woo, Jong-Myung & Kim, Choul-Young & Ban, Tae-Won & Park, Pangun & Jung, Bang Chul. (2019). *Channel Measurement and Feasibility Test for Wireless Avionics Intra-Communications*. *Sensors*. 19. 1294. 10.3390/s19061294.

^{ix} https://en.wikipedia.org/wiki/Direct-sequence_spread_spectrum

^x Nabil Sabor et al. *Comprehensive Survey on Hierarchical-Based Routing Protocols for Mobile Wireless Sensor Networks: Review, Taxonomy, and Future Directions*

^{xi} Wireless Avionics Intra-Communications (WAIC) Overview and Applications Agenda Item 1.17 : Status of Securing a Spectrum Allocation for Wireless On-Board Safety Services, and on implementing a regulatory framework and architecture Future of Instrumentation & Internet Workshop May 4, 2015 Michael R Franceschini Engineer Fellow

^{xii} Akbilek, Alper et al. "Analysis of IEEE 802 . 11 ax High Efficiency WLANs for in-Vehicle Use." (2019).

^{xiii} Bits & chips [article](#) on Signify and Latecoere deal

^{xiv} <https://www.aero-mag.com/aircraft-cabling-twi-surflow-system/>

^{xv} Akram, Raja Naeem & Markantonakis, Konstantinos & Kariywasam, Sharadha & Ayub, Shahid & Seeam, Amar & Atkinson, Robert. (2015). *Challenges of security and trust in Avionics Wireless Networks*. 4B1-1. 10.1109/DASC.2015.7311416.

^{xvi} https://en.wikipedia.org/wiki/Information_security#Information_security_culture

Executive Board

Navigation address: De Zaale, Eindhoven
P.O. Box 513, 5600 MB Eindhoven
The Netherlands
www.tue.nl

Author
Asterios Souftas

Order issuer
Kees Nuyten

Date
21 February 2020

Version
1.0

Appendix C

Wireless Avionics and Radio altimeter: Coexistence report

Table of contents

Title
Wireless Avionics and Radio altimeter:
Coexistence report

Contents

| | | |
|------------|---|-----------|
| 1 | Intro | 3 |
| 2 | Radio Altimeter: Operation | 4 |
| 2.1 | Context and definition | 4 |
| 2.2 | Employed technology | 4 |
| 3 | Conflicts with radio altimeter and wireless avionics | 6 |
| 3.1 | Interference to the RA | 6 |
| 3.2 | Interference to wireless avionics | 6 |
| 4 | Mitigation techniques | 7 |
| 4.1 | Channel hopping techniques | 7 |
| 4.2 | Spatial mitigation techniques | 7 |
| 5 | EUROCAE assistance | 9 |
| 6 | Conclusions | 10 |

1 Intro

Currently, the program “Wireless technologies in future aircraft” is in the definitions and analysis phase. During brainstorming sessions, focus was given to specifying the operating frequency of the proposed wireless system. In recent developments (2015), ITU-R (International regulatory body for Telecommunications) has allocated the frequency band of 4.200 MHz – 4.400 MHz for safety based wireless avionics networks. This represents an opportunity for wireless avionics since this band will have predictable behaviour (no interference) and universal application.

However, this frequency band is currently being used by a very important equipment to modern aircraft: the radio altimeter. This means that any proposed wireless avionics system should be able to effectively share radio resources with the RA (Radio Altimeter). The proper operation of the RA should be maintained while preserving the predictable behaviour of the radio channel for wireless avionics.

The **objective** of this report is to investigate the potential coexistence between the RA and a proposed wireless avionic system. Moreover, a full coexistence study or the consideration of other frequency bands is outside the **scope** of this document.

The structure of this report is as follows. First (2), the operation of the radio altimeter will be discussed. Then (3), the potential problems and threats of the simultaneous deployment of the two systems (RA and wireless avionics) will be analyzed. This will be followed (4) by proposed mitigation techniques and (5) an outline of the potential cooperation with European aviation technology consortium EUROCAE. Lastly, a conclusion section (6) will be included.

2 Radio Altimeter: Operation

The Radio Altimeter is an essential part of the modern aircraft. In this chapter, its function to the aircraft system will be presented and analyzed.

2.1 Context and definition

A radio altimeter is an electronic device capable of measuring the height of the aircraft with regard to immediately below terrain. The RA system is part of the bigger Ground Proximity Warning System (GPWS), the mission of which is to prevent controlled flights into terrain (CFIT). It is used during critical phases of the flight: take-off and landing and is the primary source of information when visibility is low.

As a measurement tool, it is different than the barometric altimeter. The barometric altimeter measures height between a predefined point (usually sea level) while the RA measures the distance between the craft and the ground directly below. It is a reliable system with an error margin of 3 feet (~ 1 meter). It is also used as feedback in the autopilot system.

2.2 Employed technology

The Radio altimeter, as implied by the name, is based on the principle of the radar system. It is essentially an antenna oriented towards the ground that periodically transmits RF signals within the 4.2 – 4.4 GHz band. The height is calculated based on the time it takes for the signal to be reflected back at the RA.

Modern RA's usually implement this functionality by relying on Frequency Modulated Continuous Wave (FMCW) technology. This means that the RA antenna transmits in an (linear) increasing frequency ramp, as shown in the next figure (frequency chirp). The RA periodically (every interference time T_I) sends a signal with a slightly different part of the spectrum with bandwidth B_W . The whole cycle is repeated every T_C seconds and utilizes a part of the total frequency band (B_S). When an original signal is reflected back at the RA, based on the frequency of the signal, the RA can determine how much time has passed since this signal was generated thus precisely calculating the distance. Example technical characteristics of civilian aircraft RAs are given in the following table.

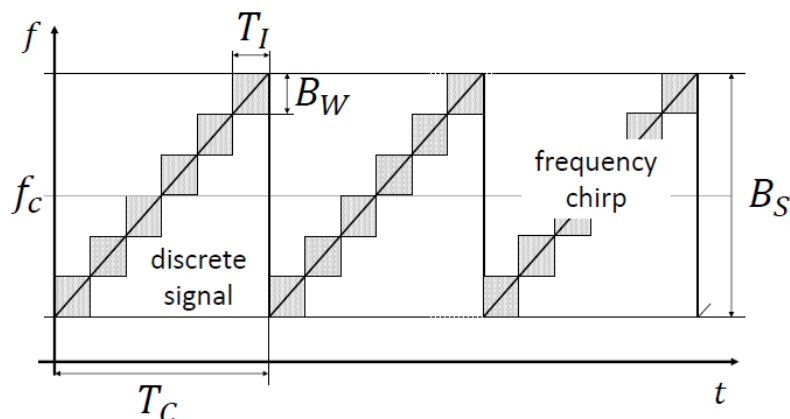

| Parameter | RA Type A | RA Type B |
|---|------------------|------------------|
| Center frequency f_c | 4300MHz | 4300MHz |
| Transmit power P_R | 0.6 W | 1 W |
| Chirp bandwidth B_s | 104 MHz | 132.8 MHz |
| Chirp duration T_c | 19.6 ms | 6.67 ms |
| Interference time T_I | 0.94 ms | 0.22 ms |

3 Conflicts with radio altimeter and wireless avionics

Two systems in the aircraft, the RA and the wireless avionics, are competing for the same resource: spectrum. This section outlines the potential problems.

3.1 Interference to the RA

RA systems are critical to flight safety. For this reason, any wireless avionic system should operate in a way that does not interrupt their normally function. This is recognized by all involved parties (consortia and regulating bodies) and many compatibility studies have been done to this direction.

The findings of this research has been that RA systems are not in danger due to the operation of wireless avionics. The high powered, directive and spatially located system of the altimeter is considered robust and a low powered wireless avionics network is not a potential threat to its safe operation.

However in order to correctly interpret the findings of such research, it is important to understand the technical assumptions that are being made. The wireless avionics devices considered have a limited transmission power. The limit for such devices is 10 mW for low data rate systems and 50mW for high rate systems. This is considered sufficient for the proper function of the RA system. Stricter restrictions are in place for systems with their antennas outside. In the outside scenario, the total equivalent isotropically radiated power density should be no more than 6 dBm per 1 MHz of used bandwidth. Furthermore, all wireless avionics antennas outside must be directional in order to limit unwanted interference.

3.2 Interference to wireless avionics

Wireless avionics systems will transport safety critical data. That means that such a system must be behave in a deterministic way and be predictable for the safe operation of the craft. For that reason, it is important to know if the proposed frequency is suitable of the use of wireless avionics and that there is no conflict with the RA.

Preliminary research indicates that wireless avionics systems will suffer severe interference from RAs. This means increased loss rate which in turn results in delays and higher latency. The following table presents the estimated impact on latency on wireless avionics, in relation to the RAs introduced in section 2.2. The wireless protocol employed is a single channel version of 802.15.4 transferring 250 kbits/s.

| Single channel 802.15.4 based | Average application layer latency (s) | Probability for delay > 2 s | Probability for delay > 4 s | Probability for delay > 8 s |
|-------------------------------|---------------------------------------|-----------------------------|-----------------------------|-----------------------------|
| RA Type A | 2 | 5% | 3% | 2.5% |
| RA Type B | 5.4 | 10% | 7.5% | 6% |

4 Mitigation techniques

A wireless avionic system operating in the proposed frequency bands with no special mitigation techniques in place will face significant problems due to the RA. Not only will such a system have big and unpredictable delays but it will also have limited access to useful bandwidth. This represents a danger to wireless avionics, as an important drive for such a development is high flexibility. This means that potential mitigation techniques ought to be investigated. In this section, potential solutions will be explored.

4.1 Channel hopping techniques

Since the RA's function is well known, a natural solution would be to simply avoid using its portion of the bandwidth. A TDMA approach together with channel hopping allows for an interference mitigation technique based on adaption to the time-frequency behavior of the RA. Essentially the usage of channel hopping enables us to assign communication resources in two dimensions: time and frequency. To this direction, a system designer can come up with a predefined sharing plan that nodes within a network can use as a schedule. It is also possible to have a perfectly adapted sequence avoiding the RA entirely, provided that synchronization with the RA is possible. The following figure shows potential examples. (SR stands for Share ratio: higher SR \rightarrow higher usage of the RA chirps frequency is being used)

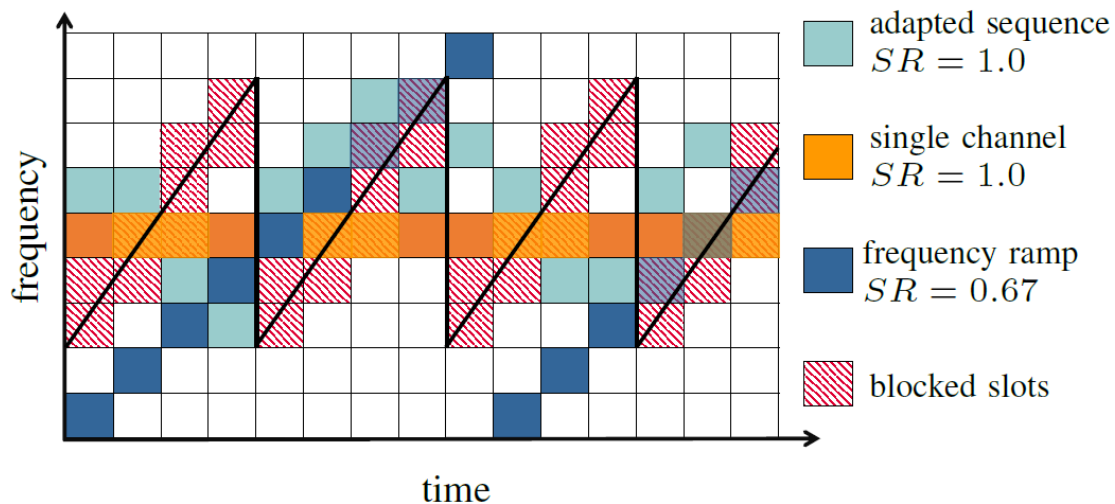

4.2 Spatial mitigation techniques

The RA antenna is located in a known position in the fuselage. Furthermore, the antenna is directive. That means that nodes located far away from the RA antenna will get significantly less interference. That suggests that the frequency used by the RA can be reused at least in some parts of the network. Assigning such frequencies can be done per gateway basis, depending on the loss rate or the SINR ratio. Again, that allows the designer to create a sharing schedule according to system requirements. A strict scheduling would occur if the RA frequency is available only to far away nodes. Alternatively, only the most disturbed nodes by the RA can be excluded from using a frequency inside the chirp.

In the following tables, the results of the two aforementioned techniques are presented (based on a recent research paper).

| Frequency ramp | Average application layer latency (s) | Probability for delay > 2 s | Probability for delay > 4 s | Probability for delay > 8 s |
|----------------|---------------------------------------|-----------------------------|-----------------------------|-----------------------------|
| RA Type A | 0.8 | 2.5% | 1% | 0.8% |
| RA Type B | 2.2 | 6.2% | 4.5% | 2.5% |

| Adapted sequence | Average application layer latency (s) | Probability for delay > 2 s | Probability for delay > 4 s | Probability for delay > 8 s |
|------------------|---------------------------------------|-----------------------------|-----------------------------|-----------------------------|
| RA Type A | 0.5 | 2% | 0.5% | 0.4% |
| RA Type B | 0.5 | 1.5% | 0.1% | 0% |

| Spatial scheduling (Conservative) | Average application layer latency (s) | Probability for delay > 2 s | Probability for delay > 4 s | Probability for delay > 8 s |
|-----------------------------------|---------------------------------------|-----------------------------|-----------------------------|-----------------------------|
| RA Type A | 0.5 | 1.5% | 0.1% | 0% |
| RA Type B | 0.5 | 1.5% | 0% | 0% |

| Spatial scheduling (Efficient) | Average application layer latency (s) | Probability for delay > 2 s | Probability for delay > 4 s | Probability for delay > 8 s |
|--------------------------------|---------------------------------------|-----------------------------|-----------------------------|-----------------------------|
| RA Type A | 1.2 | 3% | 1.5% | 1.2% |
| RA Type B | 1.8 | 3% | 1.5% | 1.4% |

5 EUROCAE assistance

During the course of this project it was determined that there is a group responsible for European aviation standardization: EUROCAE . Members of this body include representatives of important European (not exclusively) firms in the aviation industry. Examples include Airbus, Skyguide, Eurocontrol, Thales, Dassault, Fraport and Lufthansa.

With regards to the “Wireless technologies in future aircraft” project, it was identified that EUROCAE’s working group “WG-96 / Wireless On-Board Avionics Networks” has similar plans and ideas. Their main goal is to develop a well-defined MOPS (Minimum Operational Performance Standards) and MASPS (Minimum Aviation System Performance Standards) for a Wireless Avionics Intra Communication (WAIC) component that allows WAIC systems to safely co-exist with Radio Altimeters. Their current and planned work is presented in the next table.

| | Mission | Status | Cost (excl. VAT) |
|----------------|---|---------------------------------|--|
| ED - 260 MASPS | Guidance on how to demonstrate coexistence of WAIC with the RA. | Published | <ul style="list-style-type: none"> • € 0 for member • € 77 for limited member • € 110 for non-member |
| ED - XXX MOPS | MOPS for a Wireless Avionics Intra Communication System. | Draft (available circa 2022) | N/A |
| ED - 246 | Guidance on the airworthiness certification process for wireless avionics. Process specification. | Published | <ul style="list-style-type: none"> • € 0 for member • € 140 for limited member • € 200 for non-member |

In order to have access to these documents, there are three possible scenarios.

- Paying the full price for any document that is deemed important
- Joining a specific working group by becoming a limited member (€ 950 annually), and having a 30% discount in all relevant documents.
- Becoming a full member and having free access to all documents. (membership fee proportional to total business revenue ranging from € 800 to € 14.000)

6 Conclusions

The operating frequency of a wireless avionics system is of key importance to its success. The currently proposed frequency, while internationally regulated has a problem: it is also being used by the Radio Altimeter. This raises a question of feasibility: is this frequency band viable or should we select a different one? If it is viable what would be the expected impact on the wireless system and what can be done to improve the situation?

State-of-the-art research carried out by international bodies, industrial partners and independent researchers seems to indicate that it is possible to design a robust wireless avionics system centered on this band. There is minimal threat to the safe operation of the altimeter. Furthermore, it is at least possible to have a minimally functioning wireless system. Additionally, this can be improved by applying some promising mitigation techniques.

In conclusion, it seems we lack precise information to be able to predict the boundaries of such technology. However, many reasons indicate that the proposed band is suitable. These are:

- Initial simulations display encouraging results.
- A lower functioning limit is established.
- Mitigation techniques are known.

Nevertheless, the conflict with the altimeter is an important issues and should be taken into account in the requirements, definitions and system architecture. Performing more simulations, gathering data, specifying desired application specifications (e.g. data rate, data criticality etc.) and performing field tests are essential to the project success.

Executive Board

Navigation address: De Zaale, Eindhoven
P.O. Box 513, 5600 MB Eindhoven
The Netherlands
www.tue.nl

Author
Asterios Souftas

Order issuer
Kees Nuyten

Date
14 April 2020

Version
1.0

Appendix D - Definition of aircraft application and system requirements

Table of contents

Title
D3 - Definition of aircraft application
and system requirements

Contents

| | |
|---|-----------|
| Summary | 3 |
| Abbreviations and definitions | 4 |
| 1 Introduction: the aircraft application | 5 |
| 1.1 Objective | 6 |
| 1.2 Scope | 6 |
| 1.3 System architecture | 6 |
| 1.4 Motivation | 7 |
| 1.5 Operating frequency | 7 |
| 2 Requirements definition | 8 |
| 2.1 Structure | 8 |
| 2.2 Functional requirements | 9 |
| 2.2.1 Description | 9 |
| 2.2.2 Rationale | 9 |
| 2.3 Technical requirements | 10 |
| 2.3.1 Description | 10 |
| 2.3.2 Rationale | 10 |
| 2.4 Additional requirements | 11 |
| 2.4.1 Description | 11 |
| 2.4.2 Rationale | 12 |
| 3 Verification: Verification methods | 13 |
| 4 Key Performance Indicators | 14 |

Summary

This report is part of the PDEng assignment “Wireless technologies in future aircraft”. The objective is two-fold:

- To describe the selected aircraft application for the proof-of-concept demonstrator.
- To define the system requirements of the proof-of-concept demonstrator.

This document will serve as a reference for later stages in the project. Future design decisions will be made according to the agreed requirements. Furthermore, the requirements will be crucial input to the verification and validation phase.

In this report both objectives will be discussed. In section 1 the high-level system architecture is defined, in section 2 the requirements are presented and explained, in section 3 relevant verification techniques are discussed and in section 4 the key performance indicators of the proof-of-concept demonstrator are identified.

In addition, this document is expected to impact the continuation of the project after the termination of the PDEng assignment. Some of the requirements do not directly apply to the proof-of-concept demonstrator. Instead, they refer to an actual air-worthy product ready for industrial production. While this kind of requirements are not the main focus of this report, they will be presented when this is deemed important.

Considering the scope of design assignments, many aspects of this document will be expanded in the future. It is expected that some requirements will be added, some will become irrelevant and some will need further explanation. Consequently this report is a work in progress, and it is expected to change within the lifetime of the PDEng project.

Abbreviations and definitions

SARP: Standards And Recommended Practices

ICAO: International Civil Aviation Organization

ITU-R: International Telecommunication Union - Radio

EMC: Electromagnetic Compatibility

EM: Electromagnetic

WAIC: Wireless Intra Avionics Communications

EIRP: Equivalent Isotropic Radiated Power

TRL: Technology readiness level

ARINC 429: 80's avionics bus

IMA: Integrated Modular Avionics

PED: Passenger Electronic Device

Radio Altimeter (RA): Aircraft equipment used to measure flight height

KPI: Key Performance Indicator

1 Introduction: the aircraft application

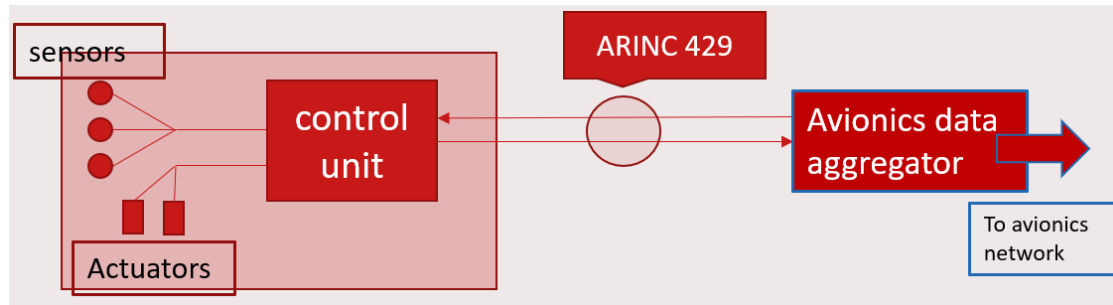

Figure 1: ARINC 429 Functional diagram

The objective of the project is to design a wireless communication system that can fulfil the role of ARINC 429 ¹avionics bus in the avionics network. The figure above shows the overview of the existing system architecture of ARINC 429. As can be seen from the figure, ARINC 429 facilitates aggregator connections. Its role is to forward flight relevant data from various control units to the main avionics network.

In order to better understand ARINC 429 operation in the broader system (and thus the purpose of the system under design) focus should be given on understanding the nature of the transmitted data. The transmitted data is the product of various control loops inside an aircraft. These control loops sometimes need to forward information about their system, like the measurement of a group of sensors or device health, to the cockpit controls. This information is presented on the cockpit displays, thus allowing the pilot to understand what is going on in important parts of the aircraft. An example could be the function of an inerting system. This inerting system needs to transmit information obtained from its sensors about the status of the fuel tank. This information is forwarded to the cockpit controls through ARINC 429.

The nature of the transmitted data has direct implications to the architecture of the wireless system. The data that is being propagated in the aircraft data system can be classified according to the following table. Based on the example given earlier, ARINC 429 facilitates the transfer of flight relevant data. This means that while this does involve information regarding the safe operation of the flight, it is not directly connected with aircraft navigation system. Thus, the designed system should guarantee a certain level of reliability and low delay. This will be further explained in further sections.

| Flight entertainment | Flight relevant | Flight critical |
|----------------------|------------------|-----------------------|
| Low reliability | High reliability | Very high reliability |

Table 1: Data reliability classes

¹ The Evolution of Avionics Networks from ARINC 429 to AFDX, Christian M. Fuchs

1.1 Objective

The objective of this report is to provide a document where all requirements regarding the proof-of-concept wireless avionics communication system are gathered and presented. The requirements provide direction to the design of the system, enable successful development, implementation and verification & validation at later stages.

1.2 Scope

The described requirements only apply to the proof-of-concept system that is going to be designed within the context of the PDEng assignment. The purpose is to showcase a working version of the technology, thus attaining TRL 3 status. Requirements for the final working product, or any higher than 3 TRL stage, do not fall in the scope of this document. However, several important requirements concerning the next steps in system development will be briefly mentioned in later sections.

1.3 System architecture

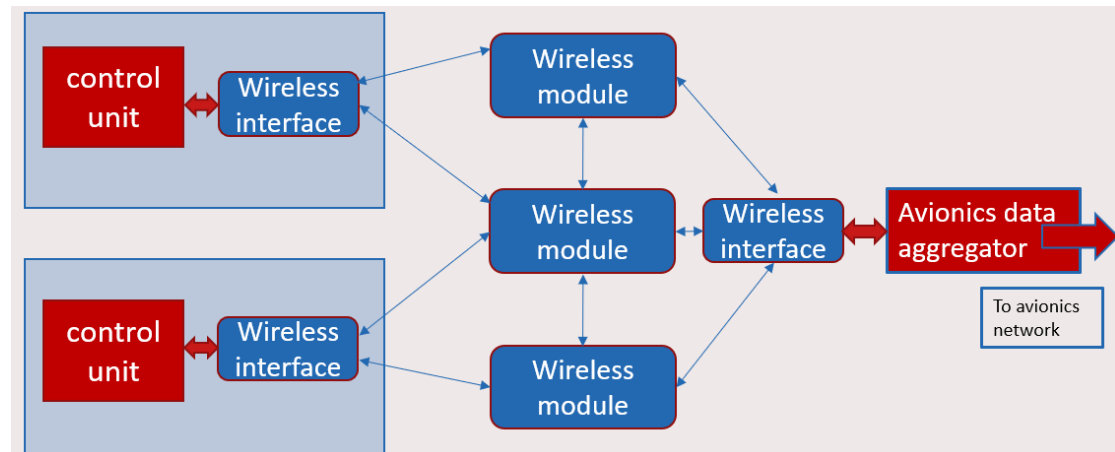

Figure 2: System architecture. Blue arrows represent wireless links and red arrows wired links.

In the figure above, a basic version of the system architecture is displayed. The system is comprised out of wireless interfaces and wireless modules.

- The wireless interfaces act as the connecting points of our system with the rest of the network and can send and receive data through wired and wireless ports.
- The wireless modules are the main part of the network. They route information to its intended destination with a wireless transmission and provide spatial diversity to increase overall system reliability.

The current architecture diagram provides only a functional overview of the designed system. Some aspects of the architecture, like the number of the modules and the length of the links, among others, are not yet defined. A complete and extensive description will be part of an architecture definition that will be provided in later planned reports (D4 and D5).

1.4 Motivation

The purpose of this system is to showcase that a wireless avionic system can maintain the same (or better) level of performance in comparison with a conventional wired system. The system should be able to offer a lighter and more reconfigurable solution without sacrificing reliability, bit rate and latency. This will be reflected on the requirements.

To this direction, ARINC 429 was chosen. This avionic data bus technology facilitates important communication with regards to flight operation while its supported data rate is relatively low. Proving that a wireless ARINC 429 module can work satisfactorily is the first step towards a broader adoption of wireless avionics communication systems. Potential next steps or alternative options that also facilitate flight relevant information, include other prominent avionics data buses like AFDX and CAN bus.

1.5 Operating frequency

Selecting the operating frequency is a crucial design choice for any wireless system. This choice results in different propagation properties, EM environment, protocols and antenna hardware. As such, it is an important aspect of system design. In this section, the selection of the operating frequency will be discussed.

In the case of wireless aircraft intra communications, the WAIC group ²is campaigning for the adoption of the 4.2 – 4.4 GHz band, getting recognition from ITU-R in 2015. That makes the WAIC band a feasible frequency for a real product, ready to be manufactured. However, since this is a proof-of-concept system, the objective is to show that the conceived technology is feasible. For the demonstrator purposes, it is acceptable to design a system operating in the ISM (2.4 GHz) band. Alternatively, a potential design choice that will be investigated in later sections would be to use both frequencies in order to provide redundancy or a fallback mechanism.

In conclusion, the following options for the operating frequency of the proof-of-concept are presented in the following table.

| |
|---|
| The operating frequency must be well-defined and must be one, or a combination of the following: |
| (Optimal) operating frequency is the WAIC band (4.3 GHz) |
| (alternative) operating frequency is the ISM band (2.4 GHz) |

Table 2: Options for the operating frequency

² <https://waic.avsi.aero/>

2 Requirements definition

This section defines the requirements in a sequence according to the structure in Table 3. The following sections contain requirements that fall to their category. At the start of each section the requirements are listed, and a short description is provided. In later sub-sections a rationale is given for each requirement presented earlier.

2.1 Structure

The requirements will be presented according to the breakdown below.

| |
|-----------------------------|
| Functional requirements (F) |
| Technical requirements (T) |
| Additional requirements (A) |

Table 3: Requirements breakdown

Functional requirements refer to the high level behaviour of the system. Examples include defining the interaction with other systems, performance in harsh environments and operating frequencies.

Technical requirements refer to target metrics that the system is aiming to achieve. Examples include supported bit rates, maximum range and maximum acceptable latency.

Additional requirements refer to the operation of the full-fledged, air-worthy product. They are not of immediate interest to the project, but some key additional requirements will be displayed for completeness.

2.2 Functional requirements

2.2.1 Description

| Requirement | Description |
|-------------|--|
| F1 | The designed system must maintain a failure rate less than 0.01 % per hour or a down time no more than 3 seconds per flight hour. |
| F2 | The designed system must operate according to the requirements in its intended EM environment. Depending on the operating frequency (see 1.5), the system must demonstrate tolerance to interference from environmental noise sources. For this project, focus will be given to the expected interference sources: |
| F2a | Interference from the Radio Altimeter (for WAIC band) |
| F2b | Interference from Passenger Electronic Devices (PEDs) (ISM band) |
| F3 | The system must be able to function as an ARINC 429 data bus. An important aspect of ARINC 429 functionality is its interfaces with the rest of the wired network. The interfaces must also work properly in the designed system. In detail: |
| F3a | The control unit must be able to send and receive data from the designed system. |
| F3b | The avionics data aggregator must be able to request data from the designed system and then effectively send and receive the data. |
| F4 | The distance between parts of the communication system must allow efficient communication between the appropriate nodes. In detail: |
| F4a | A wireless module must maintain effective communication with the intended control unit up to 50 meters. |
| F4b | A wireless module must maintain effective communication with the intended avionics data integrator unit up to 10 meters. |

Table 4: Functional requirements

2.2.2 Rationale

- F1) Conventional ARINC 429 is a very robust and reliable bus. Based on current information ARINC 429 failure rate is 10^{-6} per flight hour. In other words, individual ARINC 429 links approximately have a down time of 3.6 ms every hour. However, since the designed system is meant as a proof-of-concept it is not necessary to obtain such a low failure rate. In order to demonstrate that the final system could operate with sufficient reliability, it is enough to achieve a failure rate of 10^{-3} - 10^{-4} per link (approximately 3 seconds down time per hour of operation). In principle, it should be demonstrated that it is reasonable to expect that with better components and/or more specialized approach it is possible to achieve higher reliability.
- F2) In order to guarantee that the system operates as intended, we must take care that it can work in the environment it is going to be deployed. In this case, it is important to take into consideration the induced EM noise. As different operating

frequencies mean different noise sources are present, it is important to know what the frequency of operation of the final system will be. For the purpose of the proof-of-concept we must demonstrate that our designed system is able to operate in a tough EM environment. For this reason, passenger PEDs (radiating in the ISM band) and the RA (radiating in the WAIC band) are deemed the main sources of interference we should demonstrate our system is immune to.

- F3) The usefulness of ARINC 429, or any data bus, relies on efficient communication with parts of the data network that it is supporting. A wireless version of ARINC 429 is not different: it is crucial to design a system that is compatible with the systems that it is going to support. The simplest way to guarantee compatibility is to retain the word format of the ARINC 429 protocol.
- F4) In a wired communication system, the range of communication is an inherent property of the system since it is essentially defined by the length of the wire. In a wireless system it is not obvious what the effective communication range is. Factors like the operating frequency, obstructions between the path between the nodes and receiving/transmitting antennas impact the rate at which the signal degrades. These limitations have to be taken into account and signal strength at points of interest must allow effective communication and system function with respect to the requirements.

2.3 Technical requirements

2.3.1 Description

| Requirement | Description |
|-------------|--|
| T1 | The end-to-end latency introduced by the system must be no more than 30 ms. |
| T2 | The achieved application level data transfer rate must be at least 100 kbit/s. |
| T3 | Individual nodes must emit signals with EIRP not exceeding 50mWatts. |

Table 5: Technical requirements

2.3.2 Rationale

T1) First, it is important to accurately define end-to-end latency. For the purposes of this report, end-to-end latency is the total time it takes for a data packet to travel from one end of the system to the other. With respect to system architecture and Figure 2, this means that the total time it takes from when the physical layer of a wireless interface receives a data packet to the correct delivery of the same packet to the appropriate wireless interface must be no more than 30ms. This includes the delay induced by layers 1 to 3 (propagation delay, coding delay, media access delay, the routing delay) and the computational delay.

Network latency is an important performance characteristic of all telecommunications networks. Because this system is replicating the ARINC 429 data bus, the induced latency must not surpass the delay limit of ARINC 429. Based on current

understanding, the maximum latency of ARINC 429 is 20 ms. This is not an end-to-end latency; instead, only the transmission delay is included (layers 1 to 3). For the purposes of the proof-of-concept demonstrator it is assumed that the computational delay is approximately 10 ms. This makes the total end to end-to-end latency that the system has to respect to be no more than 30ms. In case the number changes, this will be reflected in new versions of this document.

- T2) Traditional ARINC 429 supports two different bit rates: 12,5 and 100 kbit/s. For this project, the highest bit rate 100 kbit/s is chosen. However, this number does not represent the total transmitted bit rate. Instead, a metric that represents the effective information transfer is chosen. This way, non-application transferred data or overhead (coding, protocol overhead etc.) is not counted.
- T3) Any wireless system should take care to respect other devices in the vicinity and not induce noise that can harm their proper function. For wireless avionics, WAIC and ITU-R have come up with standards that define the maximum power of transmission. Respecting the standards, the maximum radiated power from any node in the designed system must not exceed the 50 mWatts of EIRP.

2.4 Additional requirements

The requirements covered in the previous sections strictly refer to the proof-of-concept demonstrator. A full-fledged, airworthy system ready to be launched to the market is outside the scope of this project. However, it is important to identify early issues that are going to be important in later stages of development. Understanding those issues and coming up with methods and mechanisms to handle them is important. For this reason, in this section requirements that will be important in later stages of development will be discussed.

2.4.1 Description

| Requirement | Description |
|-------------|---|
| A1 | The lifetime of the total system should be at least 30 years. |
| A2 | The system should be able to operate according to the requirements in all scenarios that are expected to occur during flights. In detail: |
| A2a | The system should be able to handle vibrations of expected level. |
| A2b | The system should be able to handle expected changes in temperature. |
| A2c | The system should be able to handle expected changes in humidity. |
| A3 | The system should be meet the industry's standards in terms of security. In detail: |
| A3a | The system should be able to operate according to requirements under intentional interference. |
| A3b | The system should guarantee the integrity, authenticity, and confidentiality of transmitted data. |
| A4 | The system should be optimized, resulting in a good trade off between total cost, weight, hardware choices and performance. |

Table 6: Additional requirements

2.4.2 Rationale

- A1) Commercial aircraft are typically expected to be in operation for 30 years or 60.000 flight hours. During maintenance, several parts of the aircraft are either checked for faults or even replaced. However, it is notoriously difficult to check and maintain wiring connections. The practice of “fit and forget³” is common among aircraft manufactures. On the contrary, the design principle of Line Replacement Units (LRUs) focuses on modular equipment that can easily be checked for faults and replaced quickly.

Since a wireless system that replaces a wired data bus can be seen as both an interconnection system and a LRU, it is unclear how its maintenance is going to be handled. With proper maintenance, it should be expected of the system to be functional for the entirety of the of the aircraft’s lifetime and should not require extensive maintenance and inspections. Proper definitions of the frequency of maintenance and its lifetime would be a priority for a full-fledged manufacturable product.

- A2) During flights, the environment inside an aircraft can become harsh for electronics. This should be taken into account, and any equipment installed should be able to withstand adversities.
- A3) Security is paramount in any communications network. In the case of a wireless network, security is arguably even more important since anyone with a suitable device can intercept and/or attempt to weaken the signal. This represents a significant threat and relevant strategies need to be applied early in order to ensure the safe operation of the equipment.
- A4) As technology levels mature, it is important to optimize the technology. Thus, proper trade-offs between costs and performance to be made. This is an essential step to creating a full-fledged product that confronts to the industry’s standards and aligns with the Fokker’s strategy.

³ https://www.skybrary.aero/index.php/Ageing_Aircraft_-_Electrical_Wiring

3 Verification: Verification methods

As stated in the summary, this report has two main objectives:

- guiding the design of a system by indicating what needs to be accomplished (chapter 2)
- providing clear methods and tools with which to evaluate the project after its completion.

In this section, the techniques with which the requirements will be evaluated are discussed. In the following table the verification method will be presented for each of the requirements described in earlier sections.

| Requirements | Verification method |
|---------------------|---|
| F1 (failure rate) | Avionic products are typically tested with analytical tools for reliability. By applying the appropriate mathematical methods, it is possible to come up with accurate estimates on system failure rate. These tools will be provided by Fokker. Additionally, some conventional tests will be carried out to support the analytical tool. |
| F2 (EM immunity) | Depending on the choice of operating frequency, a software simulation can be performed to showcase system immunity. Additionally, TU/e's chambers and equipment can be used to measure device emissions and susceptibility. |
| F3 (interfaces) | Testing the word format of the transmitted data to check if it is compatible with the ARINC 429 data bus. |
| F4 (link length) | An operational test where the system is set up and working can help determine if individual network nodes can communicate satisfactorily with each other. |
| T1 (latency) | The maximum latency can be measured analytically with the help of the protocol breakdown. The average latency can be measured statistically. These results can also be backed up by protocol analyzers and packet sniffers (Open source, TU/e or Fokker). |
| T2 (data rate) | With an operational test, the system bit rate can be determined. The protocol overhead is known and is a property of the system. With this information, it is possible to calculate the effective data rate. These results can also be backed up by protocol analyzers and packet sniffers (Open source, TU/e or Fokker). Additional measurements on bit error ratio and packet reception will also be carried through. |
| T3 (radiated power) | A receiving antenna in a properly set up chamber can be used to measure radiated emissions. TU/e has appropriate facilities that can be used to that end. |
| Operating frequency | A receiving antenna in a properly set up chamber can be used to measure radiated emissions. TU/e has appropriate facilities that can be used to that end. |

Table 7: Verification methods

4 Key Performance Indicators

The proof-of-concept demonstrator aims to showcase that a potential full-scaled airworthy wireless system is reliable and can be a viable manufactured product. From this perspective, the system that is being designed in this project is meant as a representation of the final product. Consequently, the performance of the demonstrator is indicative of the maturity of wireless technology. In order to properly evaluate the demonstrator, it is important to identify the most significant requirements. These requirements can act as Key Performance Indicators (KPIs) and can form a baseline that will help evaluating the readiness of the developed technology.

In the following table, the KPIs are identified

| High level properties | Requirements | Metrics |
|-------------------------------|-----------------------------------|-------------------------------------|
| Reliability | Failure rate | Less than 0.01% |
| Responsiveness | Latency | Less than 30 ms |
| Electromagnetic compatibility | Tolerance to interference sources | Demonstrate tolerance to RA or PEDs |

Table 8: KPIs for proof of concept demonstrator

These goals represent the essence of the proof-of-concept demonstrator. Achieving these requirements means that the principle of wireless avionics is viable: it is possible to create reliable and low-latency wireless networks that can perform in the harsh EM environment of an aircraft without sacrificing bit rate.

Executive Board

Navigation address: De Zaale, Eindhoven
P.O. Box 513, 5600 MB Eindhoven
The Netherlands
www.tue.nl

Author
Asterios Souftas

Order issuer
Kees Nuyten

Date
24 June 2020

Version
1.0

Appendix E - *Options for a proof-of-concepts demonstrator*

Summary

Wireless technology has lots to offer to Fokker's Electrical Interconnection Systems development program. A wireless interconnection system is lighter compared to wiring, resulting in less fuel consumption and less CO₂ emissions, which is important given recent socio-political pressure. Furthermore, a wireless intra communication system takes less space and is easier to deploy and reconfigure. To find a meaningful way to exploit the strengths that wireless technology offers, it is important to design a system that respects the requirements of its wiring counterpart. It was identified that the most important requirements are low latency, high reliability, and electro-magnetic compatibility. Furthermore, based on the prominence of avionics data communication bus ARINC 429, supporting the ARINC 429 data format is deemed important. Consequently, the objective of a proof-of-concept demonstrator for wireless avionics should be to show that it is possible to design a wireless system that can support these requirements.

To fulfil the target requirements, the designer should be aware of the overall communication architecture. Given the design of modern aircraft data communication networks, the most interesting application of wireless was found to be connecting independent controller networks to the backbone network in order to forward sensor information to the cockpit displays. This option requires minimal network changes and substitutes ARINC 429 links which are inefficient in terms of weight. The proof-of-concept demonstrator must fit within the context of wirelessly interconnecting system controllers to a wired backbone network.

In this report design tools that can enable the design of a demonstrator network that can show that an industrialized wireless avionics intra communication system is feasible, are presented. First important architectural questions are raised, and possible directions are given (section 2). This is followed by a breakdown of possible topologies and their impact on network performance (section 3). The next section deals with the applied radio technology and relevant options for the demo are discussed (section 4). The report concludes with a recap of the presented design tools and potential concepts for the demonstrator.

Table of contents

Contents

| | | |
|--------------|---|-----------|
| 1 | Introduction | 4 |
| 1.1 | Objective | 4 |
| 1.2 | Scope | 4 |
| 2 | Network architecture | 5 |
| 2.1 | Partially wireless data network | 6 |
| 2.2 | Design choices to support the architecture | 7 |
| 2.2.1 | ARINC 429 to IP encapsulation | 7 |
| 2.2.2 | Wireless gateway | 7 |
| 2.2.3 | Self-configuring vs Centrally controlled network | 7 |
| 3 | Deployed topology | 8 |
| 3.1 | Star | 8 |
| 3.2 | Mesh | 8 |
| 3.3 | Tree | 8 |
| 3.4 | Ring | 9 |
| 3.5 | Hybrid | 9 |
| 4 | Physical and Data Link layer technologies | 10 |
| 4.1 | Operating frequency | 10 |
| 4.2 | 802.15.4 variants | 10 |
| 4.2.1 | 802.15.4a | 10 |
| 4.2.2 | 802.15.4e | 11 |
| 4.3 | Software defined radio | 11 |
| 5 | Conclusions | 12 |
| 6 | References | 13 |

Appendix A: Architectural options for wireless avionics

14

1 Introduction

This document is part of the PDEng assignment “Wireless technologies in Future Aircraft”. The goal of the project is to investigate the potential capability of wireless technology to facilitate intra aircraft communications with the interest of decreasing the overall weight of the Aircraft Data Communication Network. The end deliverable of this project is a proof-of-concept demonstrator to show that based on our design concepts, it is possible to deploy a feasible wireless intra-communication system.

To prepare for the design of the demonstrator, a report detailing the system requirements of a wireless aircraft intra communication system (D3) has been submitted. In this work, it was concluded that the most important requirements that a demonstrator should meet are low latency, high reliability and tolerance to interference among other requirements. Additionally, it was also specified that it is important that the demonstrator can support the ARINC 429 data format. Consequently, the demonstrator should at minimum satisfy the requirements presented in the following table:

| Requirement | Metric |
|---|--|
| Low latency | Less than 20 ms |
| Reliability | Packet reception ratio > 99.999% |
| Tolerance to Radio Altimeter | Tolerate up to 1W ¹ from RA |
| ARINC 429 specification and functionality | Support to ARINC 429 data format |
| | Application data rate > 100 kbit/s |
| | Communication range > 30 meters |
| Max transmission power | Equivalent Isotropically Radiated Power (EIRP) < 50 mW |

Table 1: baseline demonstrator requirements

In this report, design concepts that enable the deployment of a proof-of-concept network that can meet these requirements are presented and discussed. The overall network architecture (section 2) is presented first to ground the discussion around potential designs. Furthermore, the different network topologies are presented and evaluated for the purposes of the demonstrator (section 3). This is followed by an inventory of relevant radio technologies that can handle the transmission of data of the demonstrator (section 4). The last section (section 5) is focused on concluding the discussion for design options supporting the proof-of-concept demonstrator.

1.1 Objective

The objective of this report is to present all possible design options for the proof-of-concept demonstrator. The design options must support the target requirements and be clearly explained and motivated. This design breakdown will function as input to the design phase.

1.2 Scope

The discussed topics only apply to the proof-of-concept system that is going to be designed within the context of the PDEng assignment. Definition of the final working product, or any other stage of the product higher than 3 TRL stage do not fall in the scope of this document.

2 Network architecture

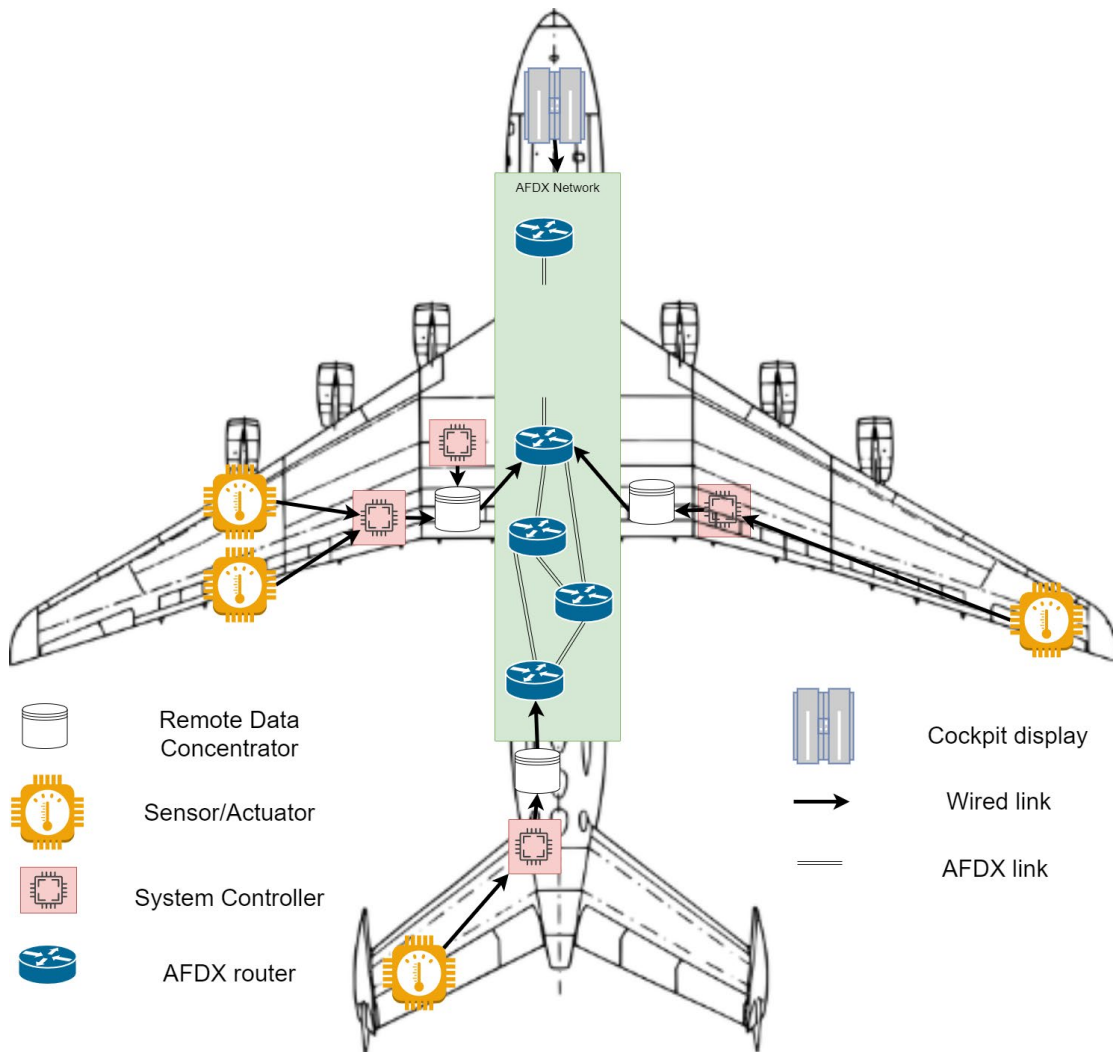

Figure 1: State-of-the-art of the Aircraft Data Communication Network

The above picture is a representation of the state-of-the-art of Aircraft Data Communication Network design. The function of the network is to provide important sensor data to the pilots' instrumentation system.

This data is produced by sensors that are typically part of local controller networks. Such networks are controlled by a central controller that is responsible for important aircraft functions (e.g. fuel inerting system, parts of the navigation system etc.). The network controller, typically located in an equipment bay area near the fuselage, forwards the necessary data to an aggregator node, the Remote Data Concentrator (RDC). Multiple system controllers are connected to a single RDC.

The RDC then is responsible to forward all sensor traffic to the backbone network. The backbone network is an Ethernet network modified to support time guarantees and redundancy (AFDX). The backbone network is responsible for routing the traffic to its destination.

2.1 Partially wireless data network

Deciding which part of the current network architecture should become wireless is not trivial. Factors like weight loss, compatibility with legacy architectures and acceptance by the industry influence the decision. Based on previous project work (report on potential architecture solutions, Appendix A) three potential options were identified: wireless links from sensors to controllers, wireless links from controllers to the backbone network and wireless backbone.

Due to gains in space and weight and easier market acceptance, it was decided that an approach involving wirelessly connecting the controllers to the backbone is the logical first step. Thus, an ADCN of next generation aircraft can use wireless technology to connect some controllers to the backbone. Such a future network is depicted on Figure 2.

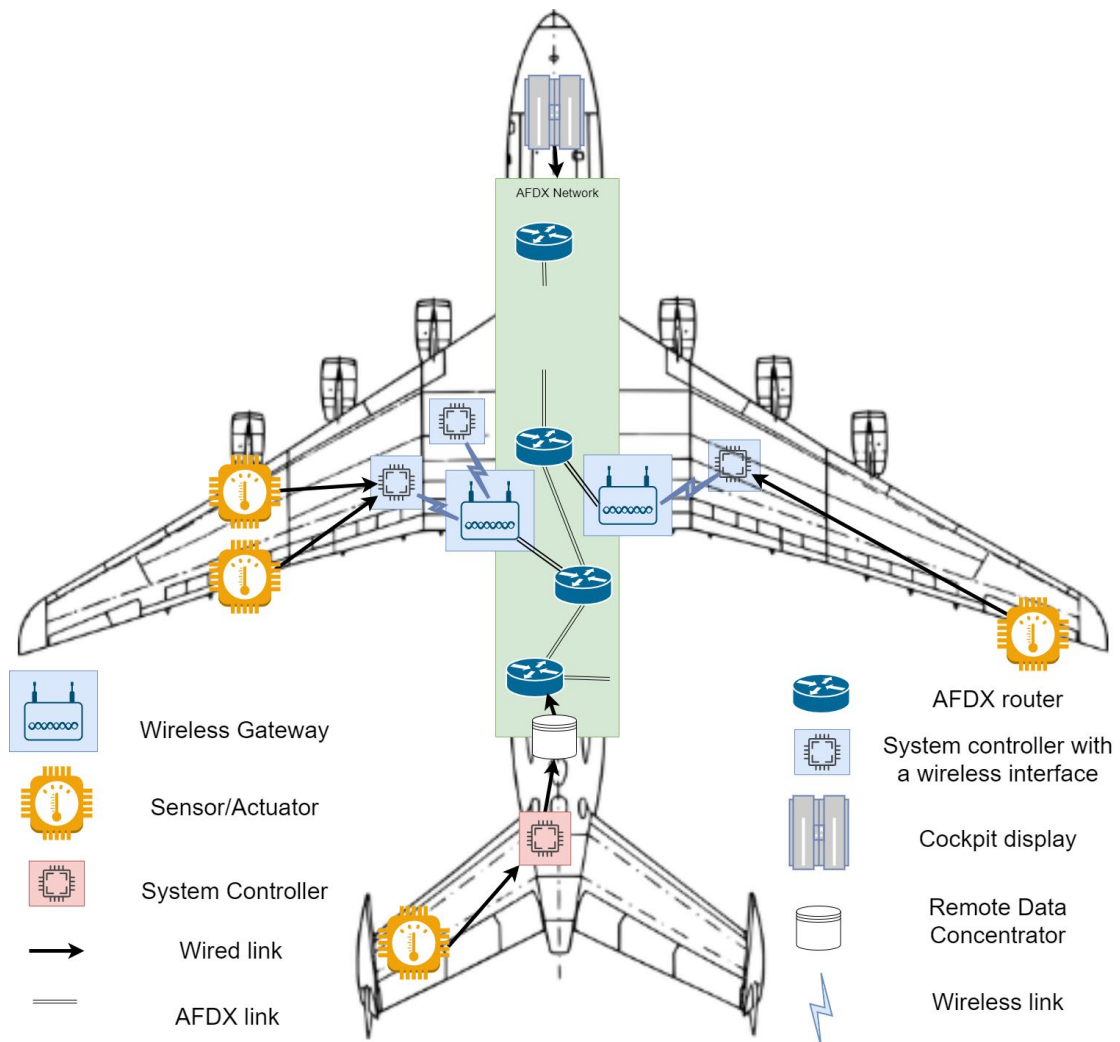

Figure 2: A future Aircraft Data Communication Network

The proof-of-concept demonstrator follows this design paradigm and aims to show that such a topology can work. The design tools discussed in following sections assume a total network design similar to the one described above and shown in figure 2.

2.2 Design choices to support the architecture

In order to support the requirements shown in the introduction ([table 1](#)), the following concepts should be incorporated to the design.

2.2.1 ARINC 429 to IP encapsulation

As identified in the introduction, the demonstrator must support the ARINC 429 data format. ARINC 429 data words are always 32 bits. Some of these bits are reserved for special use (parity, source Id, packet type etc.) and only 19 bits can be used to transmit data. The word format itself is not versatile and is not made with wireless communications in mind. However, since one of the primary goals of the demonstrator is to be able to function as an ARINC 429 link, the demonstrator must be able to support this data format. In order to support the standard while employing a packet format more suitable for our application, it is possible to encapsulate ARINC 429 data words to the payload of another protocol. For the purposes of the demonstrator, the IP protocol is considered a suitable candidate. This process (IP encapsulation) will take place before the transmission, at the controller's wireless interface.

2.2.2 Wireless gateway

The "Wireless Gateway" presented in section 2.1 is responsible for connecting individual controller networks to the wired backbone. There are two directions this Wireless Gateway can be developed:

1. Without intelligence, the wireless gateway is a device that strictly supports point-to-point communication. It connects a group of controllers to the backbone network by encapsulating their messages to IP and forwarding them.
2. By applying intelligence, the wireless gateway gains awareness of the broader network. This device can evaluate what is being sent to it by the controllers and adapt to the network traffic. For example, the network topology and deployed radio technology can change to better support traffic conditions, interference can be detected and problematic channels can be avoided or self-healing and dynamic encapsulation schemes can be enabled.

Both options are valid for the proof-of-concept demonstrator.

2.2.3 Self-configuring vs Centrally controlled network

To define the basics of the demonstrator network function, it is necessary to decide what entity will have control over the network. There are two approaches:

1. A central network controller can be installed to control the network. This will allow for better network management, more control over the network function and will give the network administrator the ability to treat traffic differently depending on the application.
2. Alternatively, the nodes can have a level of autonomy and decide themselves where they should route traffic. This allows for a more flexible system, that can more easily adapt to changes in the network and increase overall system reliability.

Current expectations are that the demonstrator will combine the two approaches. Some form of hierarchical organization is likely to be required.

3 Deployed topology

As identified in other project reports, the topology of all communication networks (the arrangement of network elements) is an important aspect of network design. The placement of nodes and the deployment of links connecting some of the nodes together affects overall network redundancy, time delays and utilized media access techniques.

In wireless networks, link deployment is not straightforward. Factors like antenna type (omni directional, directional etc.), antenna gain, propagation path, power of transmission, interference and collisions affect network connectivity. The physical topology (where are network components are placed) and logical topology (the flow of data within the network) are not interchangeable in wireless networks.

For the design of the demonstrator, it is important to be aware of this divide. Focus first must be given on the logical topology and then on how to enable it. In this section, potential logical topologies will be presented along with an exploration on how they would impact the demonstrator network.

3.1 Star

In star networks, all nodes are connected to a central coordinator node. Star network topology can be applied to the architecture described in section 2. In this case all controllers have a direct connection to the wireless gateway which acts as a network coordinator. The benefits of this approach are increased network robustness as loss of communication with one controller does not disrupt the rest of the network and easy integration of new controllers. The downsides include a more complicated medium access scheme as the number of controllers connected to one wireless gateway increases and total network failure in the event of wireless gateway failure.

3.2 Mesh

In mesh topology nodes have more than one connection to other nodes. High connectivity allows the formation of multiple paths for traffic. Mesh network topology can be applied to the architecture described in section 2. In this case, the controllers have multiple links to other controllers. Data directed to a wireless gateway is routed through to a controller node with a direct connection to the wireless gateway. Mesh networks are considered reliable since the redundant paths offer alternative routing options in case the link quality drops. However, mesh networks require the deployment of a routing mechanism increasing system complexity and potentially increasing the latency if not every node has a direct link to the wireless gateway.

3.3 Tree

Nodes forming a tree network only communicate with their parent node. This bottom-up structure eventually leads packets to their destination. As with star and mesh networks, it is possible to give an example of a tree network given the architecture of section 2. In this example, controllers send all their traffic to a “wireless bridge”. The wireless bridge then is

responsible for relaying this traffic to the wireless gateway. This approach is trading off increased latency for increased scalability and simpler network management.

3.4 Ring

Ring networks involve nodes forming a closed loop – each node is connected to its two neighbors. A variant to this, called Token ring network, involves the nodes exchanging a “token” message. Only nodes holding the token can broadcast. As an example, an application of a token ring network to support the architecture shown in section 2 is given. In this example, controllers exchange the token with their neighbors. Controllers who have data to transmit wait for their turn on the token. When they are in control of the token they can transmit to the wireless gateway. This topology can offer guarantees in terms of latency and effective bandwidth. Ring networks are often criticized for being very difficult to scale up. Furthermore, in case one node in the ring malfunctions (or the token is lost) the network fails to function properly.

3.5 Hybrid

To support the requirements, the demonstrator network topology can combine elements of different topologies. For example, a combination of star and ring topologies entails multiple star networks where all network coordinators are connected through a ring topology. The benefits and drawbacks of all the applied topologies are carried on to the hybrid topology.

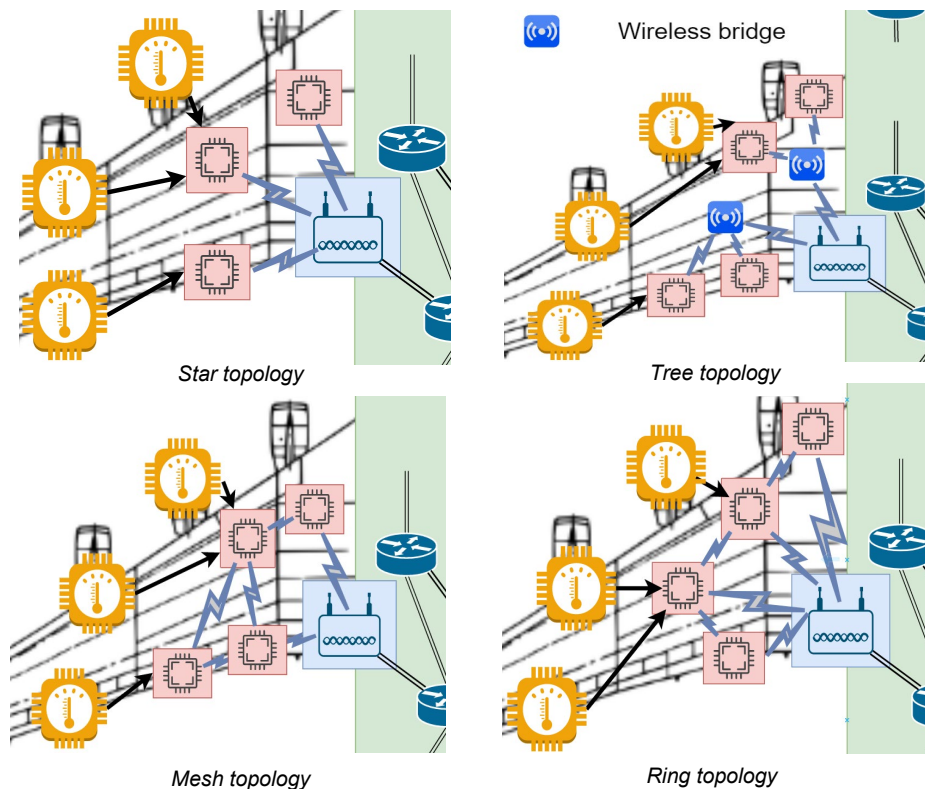

Figure 3: Examples of logical topologies

4 Physical and Data Link layer technologies

Selecting a radio technology to implement the decided architecture is an important design decision affecting the total performance of the network. For the demonstrator to meet the imposed requirements, the appropriate technology must be selected. Of prime interest is the implementation of the first two OSI layers (physical layer and medium access control layer). These layers function as the building block of any wireless system and define what kind of applications the system can support. In this section, the prevalent layer one and two technologies capable of supporting the demonstrator will be analyzed.

4.1 Operating frequency

Selecting the frequency band at which a wireless signal will be transmitted has a big impact on link quality. The situation is further complicated in aviation applications: all frequency bands are dedicated to a specific function and there is little room for deviation. For this reason, a specific frequency band has been allocated for wireless avionics intra communications by the International Telecommunications Union (ITU). This band (called the WAIC band) covers the 4.2-4.4 GHz spectrum and is exclusive to wireless avionics apart from the Radio Altimeter, which also operates on the same frequency band.

However, for the demonstrator an alternative radio band is preferable. The ISM band of 2.4-2.5 GHz is instead favored. Most radio protocols, antennas and other radio equipment are designed for this band. Operating on the WAIC band would mean that the protocols and equipment would have to be adjusted or designed from start. This process is more suited to higher TRL stages where industrialization is important. For the demonstrator, the purpose is to showcase the feasibility of reliable wireless communication. It is expected that results and conclusions made on the ISM band will be transferable to a system operating in the WAIC frequency.

4.2 802.15.4 variants

802.15.4 is an IEEE protocol defining the first two OSI layers of communication. The protocol is built specifically for low power, reliable communications that can tolerate interference. It has been used widely, especially for Internet of Things applications. Additionally 802.15.4 is commonly suggested for wireless avionics use – not only has it been officially endorsed by WAIC but it has also served as a benchmark for various research papers ² ³. 802.15.4 variants that are a good fit for the demonstrator and can support the agreed requirements are presented next:

4.2.1 802.15.4a

802.15.4 is a backwards compatible amendment to 802.15.4. The standard aims to make 802.15.4 even more versatile and be able to adapt to the demands of the IoT market. Its features include more options for the physical transmission, including Chirp Spread Spectrum

(CSS) and Ultra-Wide Band (UWB) transmission. Additionally, the standard also introduces changes in the Medium Access Control (MAC) in order to support the new physical transmission modes. The intent was to offer a protocol capable of supporting consumer requirements like precision ranging, extended communication range, and robustness against interference.

This particular variant is very interesting to the development of a demo to showcase reliable and low latency wireless intra communication avionics. The many optional modes it can support, and the available physical and MAC specified mean that we can adjust this protocol to suit the demonstrator needs. This is further exemplified by the actions of other researchers working in wireless communication in aerospace. In particular, an European Space Agency (ESA) team is using 802.15.4a ⁴ as the communication protocol that supports their prototype. Their main reasoning was that UWB physical mode of transmission can tolerate the aerospace environment which is usually clutter with metallic objects and other reflectors while respecting the sensitive electronic equipment put in close proximity to transmitters thus keeping EMC issues to a minimum. These arguments coupled with the abundance of devices that support the standard make 802.15.4a an attractive choice.

4.2.2 802.15.4e

802.15.4e is a popular amendment to the original standard, aimed to better support wireless industrial communication. The standards MAC has been changed and now supports channel hopping and scheduled communications. The newly supported MAC modes are Time Slotted Channel Hopping (TSCH), Deterministic and Synchronous Multichannel Extension (DSME), and Low Latency Deterministic Network (LLDN). This approach results in a more predictable system, with time guarantees and robustness against interference sources.

This amendment has been extensively deployed to support industrial communications. An industrial setting is similar to aerospace both in terms of propagation environment and requirements. 802.15.4e and the tools it offers to network designers have also been used as benchmarks to evaluate the feasibility of wireless avionics ⁵. Its popularity combined with its deterministic behaviour make this amendment interesting for the demonstrator's purposes.

4.3 Software defined radio

Software defined radio refers to any communications system where all functions are implemented by means of software handled by general purpose hardware. Instead of relying on filters, amplifiers, modulators/demodulators etc., specific algorithms are designed to perform the same operations on the received signal by the antenna. This allows for a versatile communication scheme, able to adapt to specific application requirements. Additionally, this means that interference sources can be identified and acted upon, resulting in robust communication. Attributes like versatility and robustness make Software Defined Radio (SDR) a radio technology that is very interesting for wireless avionics.

International design teams seem to agree on the positive assessment of SDR for wireless avionics. Korean researchers developed their own SDR wireless avionics transceivers to perform a feasibility test on the proposed technology ⁶. SDR technology seems to be capable of supporting the agreed requirements and can always be modified to support additional functionalities, making it an excellent choice for the demonstrator.

5 Conclusions

Having defined the high-level requirements and the envisioned architecture, it is possible to initiate the design phase of the demonstrator. To support the design phase it is necessary to organize the available design tools and critically evaluate them with regard to the agreed requirements. Critical design tools to support the demonstrator are presented next.

- IP encapsulation/de-encapsulation of ARINC 429 words is a reasonable way to transmit ARINC 429 words without being limited by the ARINC format.
- Intelligent gateways that can perform more functions than relaying data from point A to point B (controller to backbone and vice versa). For example, the wireless gateways can support routing functions or efficiently perform IP encapsulation.
- Centrally controlled wireless nodes through a wireless coordinator. This would allow for clear network management and prioritization of certain types of traffic.
- Star, Mesh, Ring, Tree and hybrid topologies. Each offers a unique mix of strengths and weaknesses.
- Deployment of 802.15.4 devices. This family of protocols can support low latency and high reliability and is widely popular and supported.
- Deployment of Software Defined Radio nodes. SDR technology is versatile and adaptable and could prove the basis of a fully-fledged industrialized system.

These design choices define the toolset that is going to be applied to the demonstrator. In the start of the design phase, these ideas will be evaluated, and some will be incorporated to the proof-of-concept demonstrator.

6 References

- ¹ L. Hanschke, L. Krüger, T. Meyerhoff, C. Renner and A. Timm-Giel, "Radio altimeter interference mitigation in wireless avionics intra-communication networks," 2017 15th International Symposium on Modeling and Optimization in Mobile, Ad Hoc, and Wireless Networks (WiOpt), Paris, 2017, pp. 1-8, doi: 10.23919/WIOPT.2017.7959893.
- ² Stankunas, J & Rudinskas, Darius & Lasauskas, Eduardas. (2011). Experimental Research of Wireless Sensor Network Application in Aviation. Electronics and Electrical Engineering. 111. 1392-1215. 10.5755/j01.eee.111.5.353.
- ³ Wu, Jian & Yuan, Shenfang & Zhou, Genyuan & Ji, Sai & Wang, Zilong & Wang, Yang. (2009). Design and Evaluation of a Wireless Sensor Network Based Aircraft Strength Testing System. Sensors (Basel, Switzerland). 9. 4195-210. 10.3390/s90604195.
- ⁴ Puschita, Emanuel & Ratiu, Ovidiu & Drobczyk, Martin & Panagiotopoulos, Nick & Kirei, Botond Sandor & Vos, Stefan & Ratiu, Vlad & Firschau, Thomas & Pastrav, Andra & Palade, Tudor. (2019). A UWB solution for wireless intra-spacecraft transmissions of sensor and SpaceWire data. International Journal of Satellite Communications and Networking. 38. 10.1002/sat.1307.
- ⁵ P. Park, S. Coleri Ergen, C. Fischione, C. Lu and K. H. Johansson, "Wireless Network Design for Control Systems: A Survey," in IEEE Communications Surveys & Tutorials, vol. 20, no. 2, pp. 978-1013, Secondquarter 2018, doi: 10.1109/COMST.2017.2780114.
- ⁶ Bang, I., Nam, H., Chang, W., Kim, T., Woo, J. M., Kim, C. Y., Ban, T. W., Park, P., & Jung, B. C. (2019). Channel Measurement and Feasibility Test for Wireless Avionics Intra-Communications. Sensors (Basel, Switzerland), 19(6), 1294. <https://doi.org/10.3390/s19061294>

Executive Board

Navigation address: De Zaale, Eindhoven
P.O. Box 513, 5600 MB Eindhoven
The Netherlands
www.tue.nl

Author
Asterios Souftas

Order issuer
Kees Nuyten

Date
November 2020

Version
2.0

**Appendix F - *Definition of proof-
of-concepts demonstrator***

Summary

This report is part of the PDEng assignment “Wireless Technologies in Future Aircraft”. In the context of the assignment, a wireless demonstrator network is to be designed. The demonstrator’s design goal is to provide a wireless ARINC 429 communication service.

The objective of this report is to define and describe the design of the demonstrator network. The intent is to support the design philosophy through outlining key design requirements explaining the function of the ARINC 429 communications bus. This is followed by the presentation of the functional architecture of the network. The breakdown of potential implementation options, the data and management planes and the definition of the network components helps ground the functional architecture of the demonstrator network. The report continues to discuss the implementation architecture. The discussion involves the different strategies to generate input and handle output along with the deployed radio modules and a definition of the communication’s protocol stack. To address all aspects of the design, the topic shifts to supporting software development. Finally, the outline of the testing and validation setup is provided.

Table of contents

Contents

| | | |
|----------|---|-----------|
| 1 | Introduction | 4 |
| 2 | Demonstrator network concept | 6 |
| 2.1 | The ARINC 429 communication bus | 6 |
| 2.2 | The demonstrator case: Wireless ARINC 429 network concept | 7 |
| 3 | Requirements overview | 9 |
| 3.1 | Functional requirements | 9 |
| 3.2 | Technical requirements | 10 |
| 4 | Demonstrator functional architecture | 11 |
| 4.1 | Conversion to/from the ARINC 429 data format | 11 |
| 4.2 | Network node classes | 12 |
| 4.3 | Demonstrator network functional architecture | 13 |
| 4.4 | Demonstrator network control and management view | 14 |
| 5 | Implementation architecture | 15 |
| 5.1 | Input options | 16 |
| 5.2 | Output options | 17 |
| 5.3 | The design process | 17 |
| 5.4 | Network nodes and communication technology | 18 |
| 5.4.1 | Radio module deployment | 19 |
| 5.4.2 | The protocol stack | 20 |
| 5.4.3 | Software Defined Radio platform | 20 |
| 5.5 | Mechanisms for high reliability and low latency | 21 |
| 6 | Application software implementation | 22 |
| 7 | Testing scenarios | 23 |

1 Introduction

The aviation industry is currently facing political pressure to decrease flight related carbon emissions. As such, aircraft manufacturers are looking for ways to decrease aircraft fuel consumption. The pursuit of making flights more sustainable is affecting aircraft design, resulting in a push for lighter aircraft.

Fokker Elmo acknowledges this trend and aims to adopt new and disruptive technologies to decrease the weight of the aircraft electrical interconnection system. In this context, Fokker Elmo is considering deploying a wireless electrical interconnection system.

The first step in the deployment of wireless networks for aircraft intra communication is to show the feasibility of wireless technology. Current electrical interconnection systems are a very robust and reliable means of communications. A wireless demonstrator must display similar performance. It is important that the demonstrator gives confidence that wireless technology can facilitate low delay and high reliability links.

High reliability and low latency are typically a major challenge in the deployment of wireless networks. Wireless links are not based on a dedicated medium like wiring. Instead, wireless networks depend on a shared medium which can lead to unpredictable behaviour. Obstructions to the line of sight, interference and other physical phenomena contribute to higher packet reception errors. Traditional solutions to combat high error rates like acknowledgement messages and handshake mechanisms increase end-to-end latency. Additionally, the network is susceptible to jamming attacks and packet interception. The time-variant behaviour of the communication medium, the difficulty of ensuring reliability without resorting to extra messages and security concerns have made the industry reluctant to adopt wireless communications.

Developments in technology and design practices can address the identified problems of wireless communications. Relevant mechanisms to increase reliability and decrease latency include Forward Error Correction (FEC), diversity (coding, spatial, time, frequency), active redundancy (sending more than one instance of the same message), link monitoring and resource (frequency, time and code) reservations. These options form the design space of the assignment and their implementation will be explored in this report.

Furthermore, wireless technology provides an opportunity to rethink the design of the electrical interconnection system. A wireless network can be easier to reconfigure, maintain and upgrade, while it also doesn't rely on connectors which are a common cause for failures.

Consequently, the design of the demonstrator is focused on showcasing that wireless technology can support versatility in network design without sacrificing reliability and latency. Thus, the objective of this report is to present a system architecture and design concepts capable of supporting a demonstrator showcasing the strengths of wireless technology without the respective pitfalls.

The scope of this report includes the functional architecture of the demonstrator network and high-level concepts and mechanisms to support the architecture. The exact specification of the detailed implementation or further detail is outside the scope of the report.

2 Demonstrator network concept

2.1 The ARINC 429 communication bus

Before delving into the requirements, it is important to understand the basic premise of the demonstrator network. For this assignment, the main objective is to create a wireless emulation of the ARINC 429 communication bus. Figure 1 shows a functional schematic of a common deployment of the ARINC 429 bus.

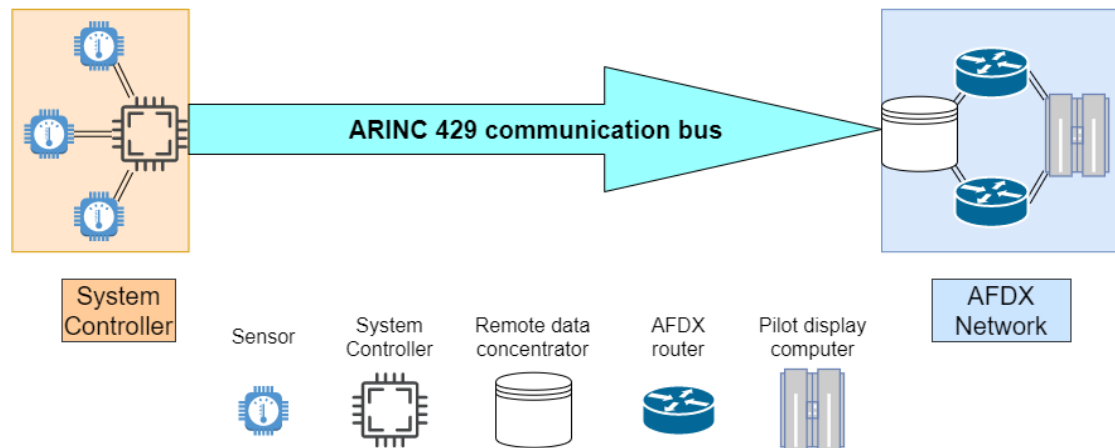

Figure 1: The function of ARINC 429 communications bus

As shown, the ARINC 429 bus is commonly used to forward data from a “System Controller” to the “AFDX Network”.

The System Controller represents a closed controller network. Such networks have a dedicated function within an aircraft (e.g., fuel inerting, navigation etc.). This function is usually handled locally. However, such systems need to occasionally send status reports. These status reports contain information that needs to be displayed to the flight crew. The system controller is the entity responsible for sending this information in the form of ARINC 429 words (by ARINC 429 specification the basic data unit of ARINC 429 is called a “word” and is a coded array of 32 bits – more information can be found in the appendix).

The status reports generated by the System Controllers must be delivered to the cockpit displays. Usually, the System Controllers do not directly send their data to the cockpit. Instead, the status reports are forwarded to a concentrator unit the Remote Data Concentrator (RDC). The RDC is connected to the aircraft’s data backbone network known as the AFDX Network. This Network is responsible for forwarding the status reports to the cockpit displays.

The ARINC 429 communication bus is mainly used to connect System Controllers with the AFDX Network. The ARINC 429 bus is commonly used in commercial airplanes.

For this assignment the objective is to emulate the characteristics of the standardized ARINC 429 bus in a wireless demonstrator network. The concept of the wireless ARINC 429 network is further explained in the following section.

2.2 The demonstrator case: Wireless ARINC 429 network concept

The demonstrator system supports the functionality of the ARINC 429 communication bus. The demonstrator that will be designed, involves replicating a common use of ARINC 429: connecting System Controllers to the AFDX backbone network.

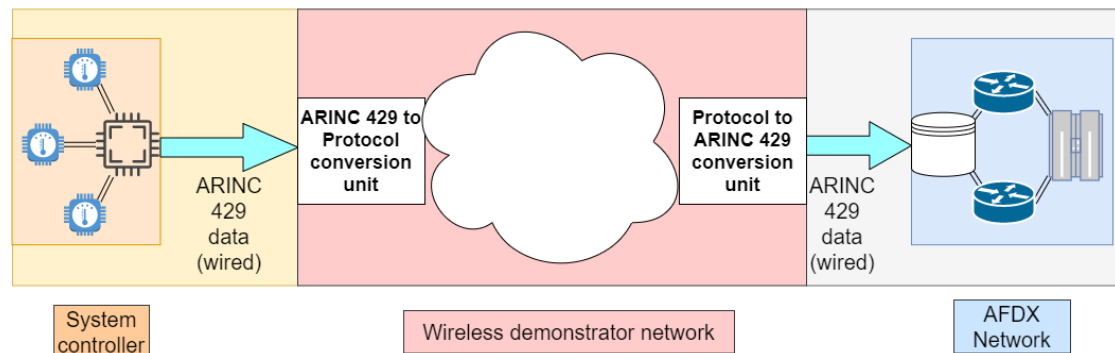

Figure 2: Demonstrator Network functional diagram

In figure 2, a functional diagram of the wireless demonstrator system is presented. The presented concept is designed to offer transparent ARINC 429 communication links. The system controller and the AFDX backbone Network will function as if they were connected by a physical ARINC 429 communication bus. Setting total transparency as a design goal has implications for the design of the system: the ARINC 429 technical requirements and word format must be respected.

Furthermore, to design a truly transparent network it is important to define the network's interfaces. As shown in figure 2, the wireless network must offer at least one ARINC 429 to Wireless Service conversion unit to receive the ARINC 429 data from the System Controller. Similarly, the wireless network must also offer at least one ARINC 429 physical interface to forward the system controller's data to the AFDX Backbone network. These interfaces allow the network to receive ARINC 429 input to deliver it to its destination, the AFDX backbone Network.

The conversion unit that receives ARINC 429 input will be referred to as an ARINC 429 Gateway. The ARINC 429 Gateway is defined as a network node that has one ARINC 429 socket (connected to the System Controller), a converter module (converting ARINC 429 words to the wireless communication format), a communications device and an antenna. ARINC 429 Gateways receive the input from the system controller and propagate it through the rest of the network, as depicted in figure 3.

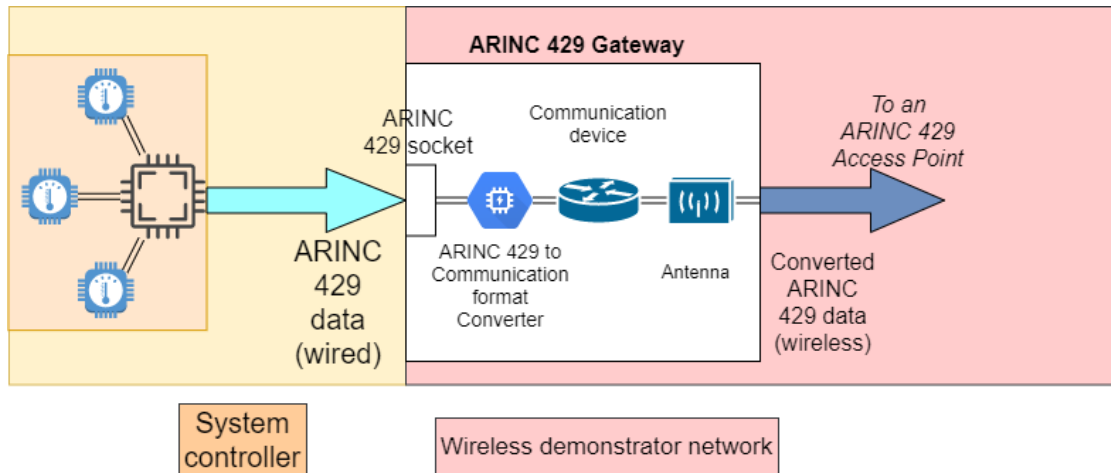

Figure 3: ARINC 429 Gateway definition

The network node that offers an interface to ARINC 429 output will be referred to as an ARINC 429 Access Point. The ARINC 429 Access Point is defined as a network node that has one ARINC 429 socket (Connecting to the AFDX Backbone network via the Remote Data Concentrator), a converter module (converting the messages from the wireless communication format to ARINC 429 words), a communications device and an antenna. ARINC 429 Access Points receive the data from other network nodes (ARINC 429 Gateways) and provide it as output in the form of ARINC 429 words, as shown in figure 4.

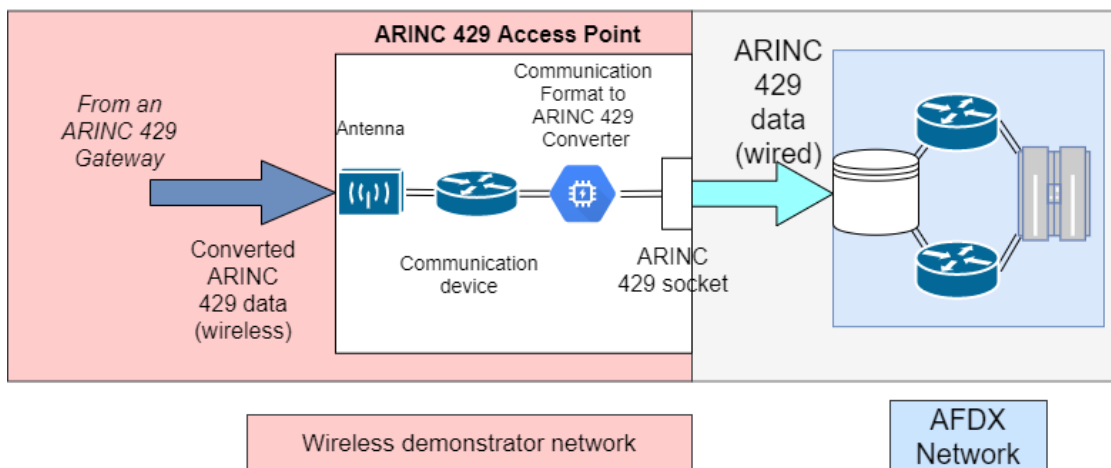

Figure 4: ARINC 429 Access Point definition

The presented breakdown of the ARINC 429 Gateways and ARINC 429 Access Points is functional. The depicted items are strictly logical entities.

The terminology of the ARINC 429 Gateway and Access Point is aligned with the definitions presented in D4. The Gateway in “ARINC 429 Gateway” refers to its function to allow data to flow from the system controller network to the wireless ARINC 429 network.

The Wireless ARINC 429 network concept assumes that all network nodes have a connection to the aircraft’s power supply. The powering of the system is beyond the scope of the project.

3 Requirements overview

In this section, the requirements applying to the design of the demonstrator will be presented. The intent is to show the focus of the design and justify the high-level design choices. Furthermore, these requirements are to be used as a reference in the validation phase of development. Further elaboration on the rationale for each requirement can be found in earlier reports (D3, D4 and D5).

Two types of requirements will be presented: Functional requirements and Technical requirements. Functional requirements refer to communication, control and management services that the demonstrator must support and how it must interact with other systems and with the human operator. Technical requirements refer to the quantification of the performance of the system.

3.1 Functional requirements

The demonstrator has two primary functions:

- offer the same service as an ARINC 429 bus.
- demonstrate techniques to support flexibility and resilience in future wireless avionics networks.

The implications of providing a transparent ARINC 429 service are further explained in the requirements below (table 1).

| Code | Description |
|------------|--|
| F1 | The demonstrator system must support ARINC 429 functionality. |
| F1a | The demonstrator must offer at least one interface for ARINC 429 input from a system controller (ARINC 429 Gateway). |
| F1b | The demonstrator must offer at least one interface for ARINC 429 output to a Remote Data Concentrator (ARINC 429 Access Point). |
| F2 | The demonstrator network must offer a management and control plane that enables reconfiguration of important communication system parameters (disable/enable redundancy, re-routing, traffic differentiation etc.) |

Table 1: Functional Requirements for the Demonstrator Network

3.2 Technical requirements

The demonstrator must at least achieve the same performance as the ARINC 429 data bus. Other avionics communication standards like CAN bus or AFDX are not the focus of the demonstrator. The ambition however is to design a system that in the future can be upgraded or improved to also facilitate other standards. The goal of supporting other avionics communication standards is secondary and as a “nice to have” requirement for the purpose of the assignment. Thus, the depicted requirements in this section are corresponding to the ARINC 429 specification.

Furthermore, the flight relevant¹ nature of the transmitted data imposes requirements on latency and reliability. Wireless transmission implies a maximum threshold on transmission power in order to respect regulations and EMC requirements. In table 2 relevant performance requirements are presented.

| Code | Requirement | Metric |
|------|---|--|
| T1 | The demonstrator must transmit data with as little delay as possible. | End-to-end latency < 20 ms |
| T2 | The demonstrator must offer reliable communications on par with established aviation standards. | Packet reception ratio > 99.99% |
| T3 | The demonstrator must at least support the data rate of the ARINC 429 bus specification. | Application data rate > 100 kbit/s |
| T4 | The maximum transmission power must respect regulations. | Equivalent Isotropically Radiated Power (EIRP) < 50 mW |
| T5 | The effective communication range must be suitable to replace ARINC 429 communication links. | Effective communication range > 15 m |

Table 2: Technical Requirements for the Demonstrator Network

(Requirement T2 reflects the error specification of the ARINC 429 communication bus. More information can be found in the appendix).

(Requirement T3 is considered the minimum acceptable requirement. With respect to the ambitions set in D4, a nice-to-have requirement is an application data rate > 1 Mbit/s).

¹ As defined in the requirements document D3, aircraft intra communication data are divided to three categories: a) Flight entertainment b) Flight relevant and c) Flight critical. The flight relevant class specifically refers to data that concerns the safety of the flight but are not directly associated to the navigation system (Fly-By-Wire). As such, flight relevant data need to meet less strict reliability requirements compared to flight critical data.

4 Demonstrator functional architecture

In this section, the functional architecture of the demonstrator network will be analysed. The conversion to network protocol packets, the different classes of network nodes, the Wireless Network functional architecture and the control plane view of the network are analysed in the following subsections.

4.1 Conversion to/from the ARINC 429 data format

The ARINC 429 bus specifications define the communications protocol stack (for more details, see Appendix). In the specifications the physical and data link layers are defined.

However, the ARINC 429 bus protocol is not suitable for modern wireless communication applications. The protocol is designed to work for a dedicated medium. The ARINC 429 protocol lacks mechanisms to avoid collisions and adapt to different traffic specifications and interference. For this reason, the wireless communications ARINC 429 network needs to rely on a different communication protocol.

The function of the wireless ARINC 429 network's communication protocol is to forward the application data (System controller sensor data in the ARINC 429 format) to the transceiver. To fulfil the system requirements, the communication protocol must support the ARINC 429 application layer.

The design space of the communication protocol is extensive. However, the solutions can be classified to two approaches: a layer 2 (data link layer) protocol or a layer 3 (IP) network protocol.

The layer 2 communication protocol is the minimal approach. Designing a layer 2 protocol is simpler and requires less time. This approach also is less constricting since the design of higher layers is left open for future work.

However, a layer 3 network approach has some considerable advantages. Such a network will display higher interoperability and seamlessly communicate with other layer 3 based networks. Interoperability is an increasingly important feature given that the expected future of aircraft data communication networks involves a combination of various technologies.

There are two main layer 3 network protocols: IPv4 and IPv6. IPv4 is the original network protocol designed as a building block for the internet. IPv6 is the successor technology that was developed to increase the number of supported connected devices. The differences between IPv4 and IPv6 can be seen in table 3.

| IPv4 | IPv6 |
|---|---|
| No end to end connection integrity | End to end connection integrity is achievable |
| No built-in security features | (IPSEC) built-insecurity feature |
| Flow identification is not available | Packet flow identification is available |
| IPv4 addressing field requires 32 bits. | IPv6 addressing field requires 128 bits. |
| The Maximum Transmission Unit (MTU) is 68 bytes | The Maximum Transmission Unit (MTU) is 1280 bytes |

Table 3: IPv4 to IPv6 comparison

IPv6 offers integrity checks, security and flow identification. However, deploying IPv6 translates to increased overhead due to the size of the addressing field. The overall size of the packets can be difficult to handle. Some radio technologies (like 802.15.4) have a standard packet size that is considerably smaller. To implement IPv6 it is important that it is implemented in a way that does not conflict with the packet size of the deployed technology.

A well-established solution to make the MTU requirement of IPv6 workable is 6LoWPAN. 6LoWPAN is a set of encapsulation and header compression mechanisms that allow IPv6 packets to be sent and received over 802.15.4 based networks. This makes 6LoWPAN an attractive option in case a 802.15.4 solution is preferred.

Determining the optimal protocol is part of the assignment. The deployed protocol will be determined in practice. Influencing factors are expected network size, development complexity, security needs and the need for traffic differentiation.

4.2 Network node classes

The demonstrator network is comprised of two different kinds of nodes. The class of the node corresponds to its particular function within the network. It is important to note that all nodes have full functionality (routing, sending packets etc.) The two network node classes are:

- ARINC 429 Gateway (3) described in an earlier subsection (3.1). Nodes that accept ARINC 429 words as input. The Gateways generate IPv6 packets containing the ARINC 429 word and transmit it to the network, intending to reach an ARINC 429 Access Point.

- ARINC 429 Access Point (2) described in an earlier subsection (3.1). Nodes that receive IP packets containing ARINC 429 words as payload. ARINC 429 Access Points provide the encapsulated ARINC 429 words as output.

4.3 Demonstrator network functional architecture

The demonstrator network is composed of five nodes: three ARINC 429 Gateways and two ARINC 429 Access Points arranged as shown in figure 5.

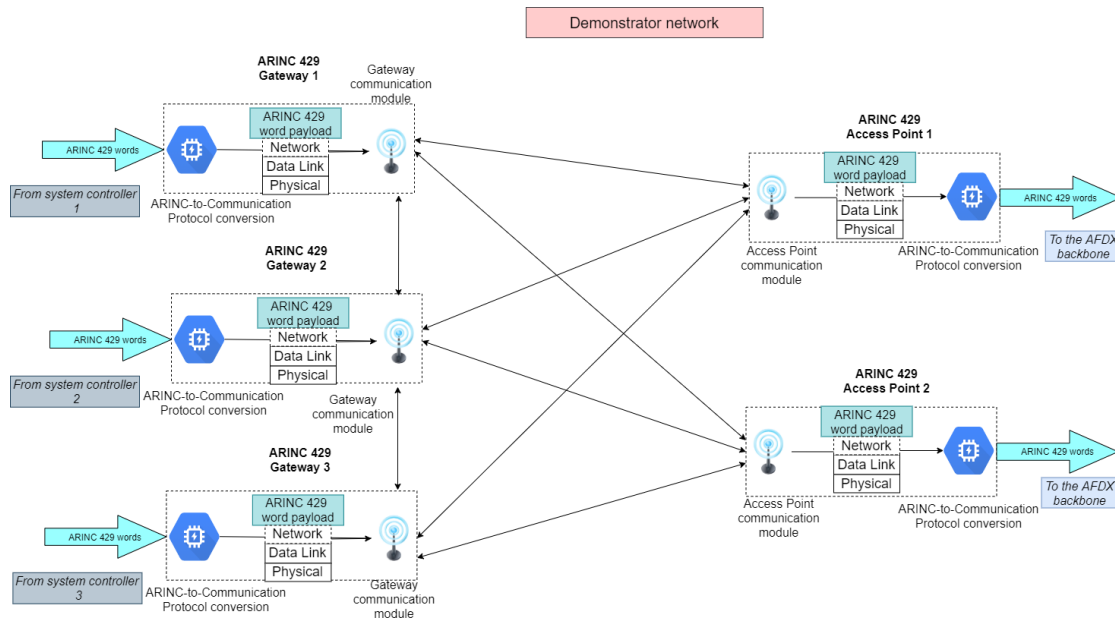

Figure 5: Demonstrator Network functional architecture

The primary function of the system is to get information from the system controllers to the AFDX backbone network.

The ARINC 429 Access Points act as the data sink of the network. To reach the AFDX backbone network, all network packets must be forwarded to an ARINC 429 Access Point.

The ARINC 429 Gateways act as the data sources of the network. The ARINC 429 Gateways are generating messages with a payload of 32 bits, corresponding to the ARINC 429 word forwarded by the system controllers. These messages are then transmitted to all available ARINC 429 Access Points.

4.4 Demonstrator network control and management view

To fulfill the requirements, it is necessary to test the efficiency of the techniques applied to design the demonstrator network under all scenarios of interest. A control and management platform is needed to handle the setup of the network and the applied tools. The management plane must offer an interface where the human operator can control the aforementioned design parameters.

With respect to the setup, it is important to give the operator the ability to control the which network nodes are turned on and off. The network must be capable to perform as intended, even in the event that some nodes fail. Controlling the nodes and the transmitting power allows to design and perform tests to demonstrate network robustness.

With respect to the applied tools, the demonstrator network will feature a variety of deployed techniques. Given the exploratory nature in the work, the impact of these techniques to key requirements like latency and reliability needs to be investigated. Consequently, the management plane should be capable to change the configuration of the wireless network. Important configuration items include routing and addressing, the MAC scheme and the scheduler (in addition to the mechanisms mentioned in table 4.)

5 Implementation architecture

In this section, the physical aspects of the demonstrator design are discussed. The implementation architecture must provide a realistic plan to implement the functional architecture. It is key to define the demonstrator setup, the source of the ARINC 429 words (input), how the output is handled (mock display) and the nature of the network nodes.

The planned demonstrator setup, including different options for particular aspects of the demonstrator, is presented in figure 6.

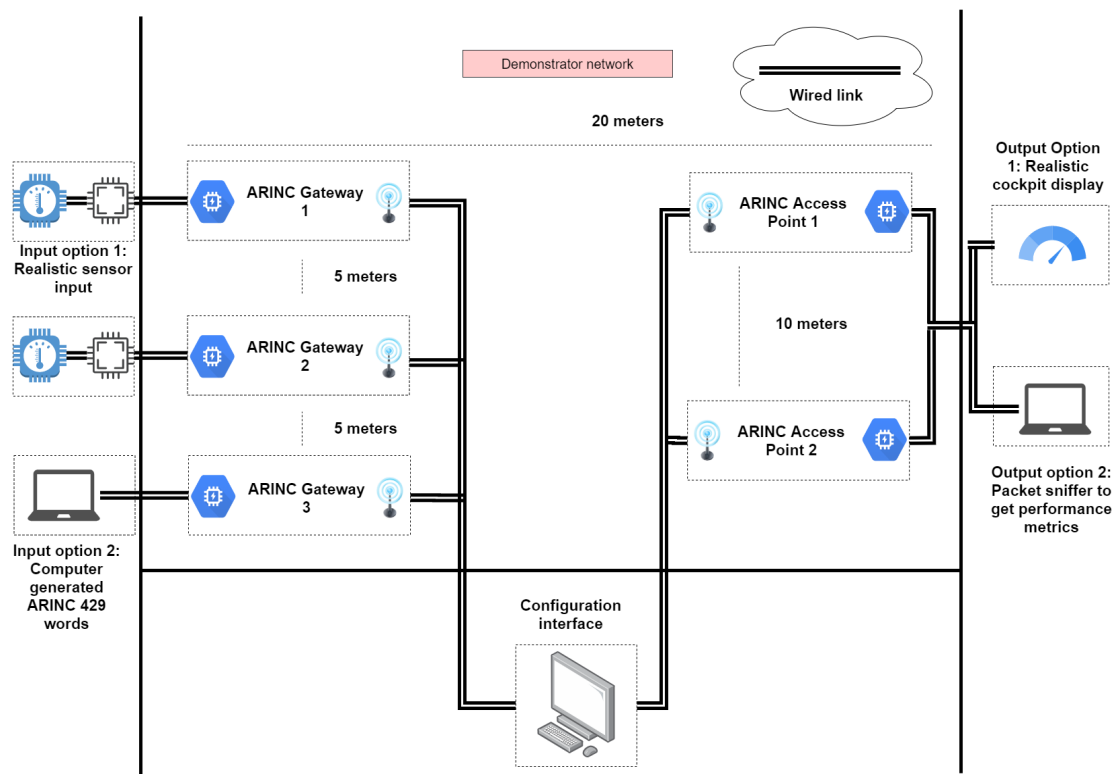

Figure 6: Demonstrator Network implementation options

This setup helps fulfil the requirement about the effective communication range (25 meters) and provides space diversity in the network.

The Configuration interface depicted in the figure, is provided by the computer that is responsible for configuring the network nodes and initiates the tests. From this platform new instructions can be given to the network nodes (shutting down one node, apply different Medium Access techniques etc.) The functionality of the configuration interface is discussed in section 4.5.

To define the physical architecture, it is necessary to define the used frequency. The frequency band for an industrialized wireless ARINC 429 network is the WAIC band (4.2 – 4.4 GHz).

However, in the demonstrator the ISM band of 2.4 GHz to 2.5 GHz will be used. This choice is influenced by the availability of equipment capable of supporting the selected frequency band. It is expected that the learning points and applied techniques to design a reliable demonstrator network operating in the ISM band can be easily applied to the industrialized network operating in the WAIC band. Furthermore, the crowded ISM spectrum provides a unique opportunity. To demonstrate that the network can tolerate the ISM band interference and maintain high reliability indicates that the applied methods can be used to form a robust network.

The presented setup is not yet complete. In the current project phase, there are important issues that need to be determined. These will be addressed in the following subsections.

5.1 Input options

The source of the input is undetermined. The two potential options are:

- Input option 1: Implement specialized software to generate ARINC 429 words and feed the ARINC 429 traffic to the ARINC access points.
- Input option 2: Use real sensors (e.g., pressure, thermal etc.) to generate realistic ARINC 429 traffic and forward it to the ARINC access points.

The demonstrator design will feature input following one of those approaches. Input option 2 is more realistic with respect to the intended application and will result in a more immersive demonstrator. Input option 1 requires a smaller time investment.

The design process will follow an incremental approach. Input option 2 is not essential for project success. In order not to risk running out of time, Input option 1 will be developed first. If all essential design activities are performed and the requirements are met while there is still time, Input option 2 will be explored.²

² For future work, the development of an avionics sensor network powered with energy harvesting can be considered.

5.2 Output options

The handling mechanism for the ARINC 429 data is undefined. The two potential options are:

- Output option 1: Forward the output to a designated computer with packet sniffer software installed. The packet sniffer software will display various network metrics (dropped packets, average delay etc.). Based on these metrics it will be possible to verify that the network fulfils the agreed requirements.
- Output option 2: Implement specialized software (toy application) that can interpret the ARINC 429 output and mimic the multi-function display of an aircraft. This software will visualize ARINC 429 sensor data with simple graphics, indicating the real time performance of the communication system.

The demonstrator design will feature only both options simultaneously. Output option q is important to demonstrate satisfactory network performance and thus must be implemented. Output option w results in a more immersive demonstrator with a clearer message.

5.3 The design process

The design approach is incremental. In order to familiarize with the network architecture and identify the problems, the first iterations of the design will feature a standardized radio module. The objective of the first iteration phase is to establish basic network functionality and roughly define the protocol stack.

A crucial design choice is the communication protocol that will run on the defined radio module. As identified in earlier work (D2, D5) there is a plethora of options. Important examples include 802.15.4 variants, 802.11 variants, cellular technology and Li-Fi.

However, given the requirements and the scope of the assignment certain options can be safely ignored. Li-Fi cannot support the range specified in the requirements, can't work without Line-Of-Sight and has difficulty with maintaining high packet reception ratio. Cellular technology requires a significant investment in time, power and equipment making it a risky option given the PDEng project time frame.

The remaining options are 802.15.4 and 802.11. Given the described requirements, 802.15.4 is deemed more appropriate. In principle 802.15.4 is capable to support the required bit rate with low errors and latency without modifications, thus making it an appealing choice to form the basis of the wireless communication system.

Furthermore, in the context of Industrial communications many ultra-reliable, low latency adaptations of 802.15.4 have been designed (TiSCH, ISA100). The industrial communication industry is also developing innovative technologies that can give real-time guarantees (EchoRing). These can be used as a source of inspiration. For these reasons, the first iterations of the demonstrator network will feature 802.15.4 enabled devices.

In future iteration phases, 802.15.4 might prove insufficient. In this case, a Software Defined radio platform can be applied. This is further discussed in subsection 5.4.3.

The current iteration plan can be found in table 4. Use case n represents the expected demonstrator exit criteria. Currently, Use case 1 is active and operational and use case 2 is being developed.

| Topic | Use case 1 | 2 | 3 | 4 | 5 | 6 | 7 | 8 | ... | n |
|---------------------|------------|----------|----------|----------|----------|---|---|---|-----|----------|
| 1 #nodes | | 2 | 3 | 3 | 5 | | | | | 5 |
| 2 #Gateways | | 1 | 2 | 2 | 3 | | | | | 3 |
| 3 #AccessPoints | | 1 | 1 | 1 | 2 | | | | | 2 |
| 4 ARINC429 input | | N | N | Mock | Mock | | | | | Sensor |
| 5 ARINC429 output | | N | N | Mock | Mock | | | | | Y |
| 6 Mock display | | N | N | N | N | | | | | Y |
| 7 PacketSniffer | | Y | Y | Y | Y | | | | | Y |
| 8 RadioModule | | 802.15.4 | 802.15.4 | 802.15.4 | 802.15.4 | | | | | SDR? Tbd |
| 9 Control | | N | N | N | N | | | | | Y |
| 10 Configuration | | N | N | N | N | | | | | Y |
| 11 Network protocol | | N | N | N | N | | | | | tbd |
| 12 Duplication | | N | N | Y | Y | | | | | Y |
| 13 Redudancy | | N | Y | Y | Y | | | | | Y |
| 14 MeassureLatency | | N | Y | Y | Y | | | | | Y |
| 15 MeassurePRR | | N | Y | Y | Y | | | | | Y |

Table 4: Wireless demonstrator network iteration plan (Y/N stands for Yes or NO, tbd stands for To Be Determined)

5.4 Network nodes and communication technology

Determining the deployed technology that can satisfy the functions of the system nodes is an important part of the implementation architecture. The OSI layers 1,2 and 3 (physical, data link and network) layer define the protocol stack. The protocol stack is then implemented by a specific radio module. In this section the design of the protocol stack and the radio modules is presented.

5.4.1 Radio module deployment

The zolertia RE-MOTE module has been selected for initial iterations. RE-MOTE is an 802.15.4 enabled IoT platform. The RE-MOTE nodes are programmed through Contiki OS. In figures 7 and 8, a picture of a RE-MOTE node and of the initial experimental setup can be seen respectively.



Figure 7: A Zolertia RE-MOTE node

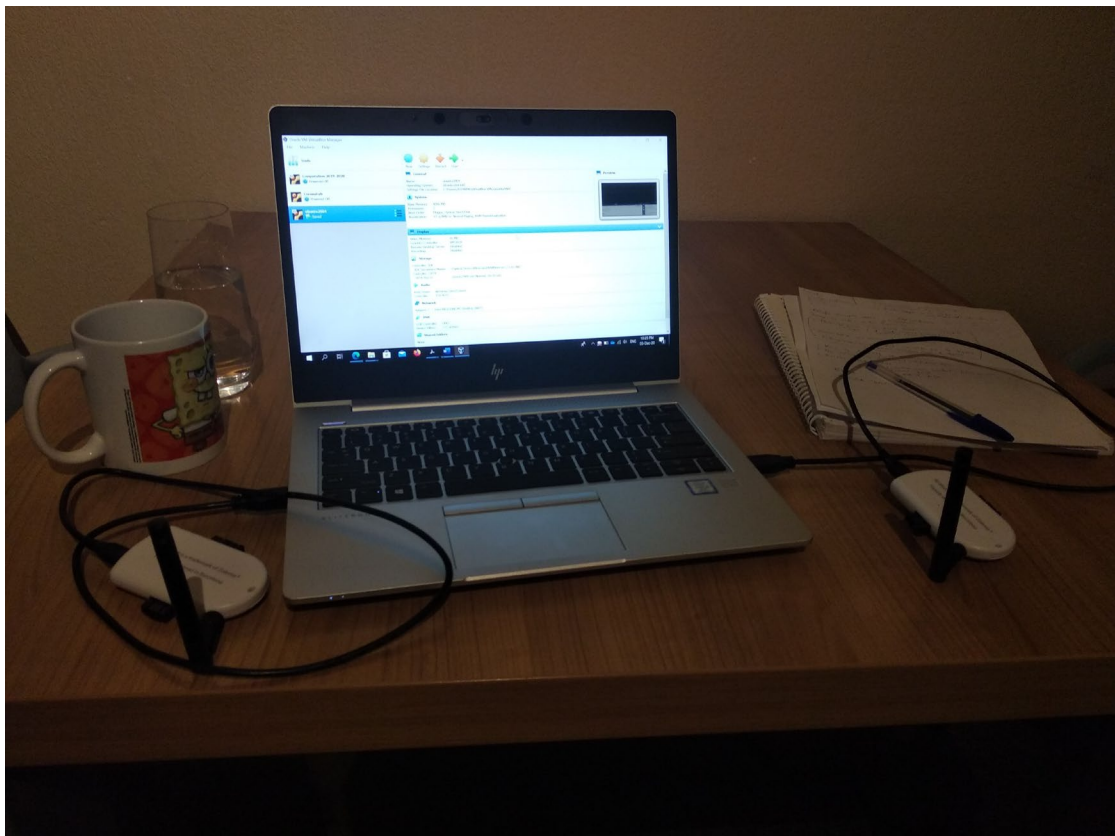

Figure 8: The initial demonstrator setup. Two RE-MOTE nodes can be seen left and right of the computer

5.4.2 The protocol stack

The rough outline of the protocol stack is shown in figure 9. Relevant design details for the protocols are presented next.

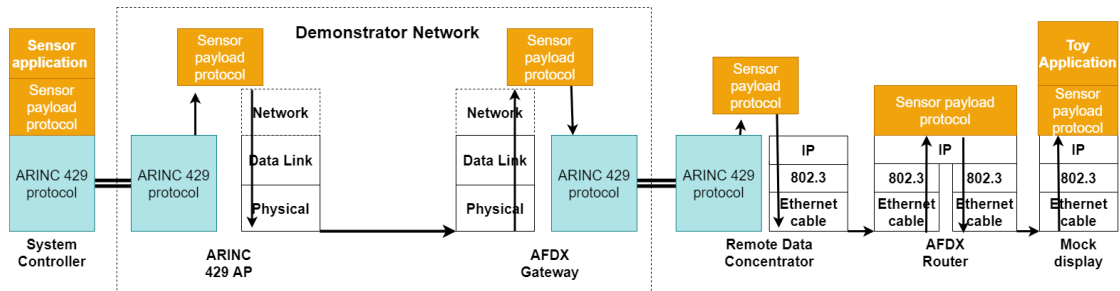

Figure 9: The protocol stack of the total communication chain

- Physical layer (layer 1) → In the first iterations of the demonstrator the physical layer will be based on 802.15.4.
- Data link layer (layer 2) → In the first iterations of the demonstrator the data link layer will be based on 802.15.4. When the SDR is introduced, the old 802.15.4 MAC is going to form the basis of the new physical layer.
- Network layer (layer 3) → Not yet in effect.

5.4.3 Software Defined Radio platform

An alternative approach to 802.15.4 nodes is to implement the network nodes with SDR (Software Define Radio) nodes. An SDR system is a general purpose processor that is connected to radio communication hardware and can be programmed to perform all kinds of communications functions. An SDR approach is versatile and allows for experimentation. Having the freedom to design all communication layers allows for the implementation of interesting techniques like spectrum sensing and cognitive radio. This flexibility makes SDR modules a viable choice for later development stages of the demonstrator network.

In future iterations, if 802.15.4 proves to have weaknesses that will be to difficult to overcome then SDR platforms will be deployed. Furthermore, an SDR node can be modified to transmit to the WAIC frequency band. This might prove useful for experimentation beyond the PDEng project.

5.5 Mechanisms for high reliability and low latency

To ensure that the functional architecture is stable and that the requirements are fulfilled, the architecture must include appropriate mechanisms to increase redundancy and reliability. The mechanisms that are considered for the assignment are:

1. Secondary Access Point → During network operation, the Access Point 1 might become unreachable or even fail. Access Point 2 can be operational and ready to fulfil the same function. (see figure 6)
2. Gateway forwarding → In case a Gateway cannot reach any Access Point, the Gateway can forward its packet to any neighbouring Gateway. As described earlier the second Gateway is likely to be able to reach an Access Point and thus increase the packet reception ratio.
3. Transmit power → In case the link quality is deemed insufficient, a network node must be able to increase its transmitting power. Of course, according to requirement T4 the transmitting power cannot exceed 50 mW.
4. Resource reservation MAC → To support time and delay guarantees the Medium Access scheme must support some form of resource reservation. If time slots and frequency channels can be reserved, then collisions can be minimized, and the network's reliability increased.
5. Channel quality routing → All network nodes must actively monitor the link quality of their connections. Packets should be forwarded through the link with the best quality.
6. Packet duplication → A last resort to ensure packet reception, is to send packets more than once. This will increase the network load and negatively impact the achievable bit rate. However, in order to fulfil the requirements it might be necessary to duplicate certain packets.

In table 5, these mechanisms are linked directly to the problem they can address.

| Mechanisms | Addressed problem |
|-----------------------------|--------------------------|
| 1. Secondary access point | Packet reception ratio |
| 2. Gateway forwarding | Packet reception ratio |
| 3. Transmit power | Packet reception ratio |
| 4. Resource reservation MAC | Latency |
| 5. Channel quality routing | Packet reception ratio |
| 6. Packet duplication | Latency |

Table 5: Compliance matrix (mechanisms on requirements)

6 Application software implementation

The design of the demonstrator, depending on the implementation, might require the development of specialized software. Such supporting software will be developed within the context of the project. The development of such code is expected to be limited in function, given the context of the PDEng assignment.

The purpose of the supporting software is to make the demonstration of the prototype network more interesting to the stakeholders. Supporting software may be used in one or more of the following scenarios:

- ARINC 429 input generation (section 4.1)
- Cockpit display emulation (section 4.2)
- Network management scripts, to automate relevant tasks

Since all of these scenarios do not directly involve the demonstrator system, it is not necessary to create a strict list of performance requirements for the developed code. However, given the research-oriented nature of the project and the probability of follow-up projects, all developed code must be well documented. This will make the code easier to understand and adapt in case this is necessary.

7 Testing scenarios

For a successful proof-of-concept demonstrator, it is important to show that the agreed requirements are fulfilled. Well planned tests are essential for successful system validation.

In table 6, potential testing concepts for the demonstrator network are presented. Each proposed concept aims to demonstrate the fulfillment of a specific requirement(s). It is also important to note that for the final testing and validation setup, multiple ideas can be combined.

| Demonstrated requirement(s) | Demonstrator testing concept |
|--|--|
| Latency, application data rate, configuration | Connecting the network to a laptop that is running packet sniffer software. By analyzing the collected data, it is possible to draw conclusions on the network's performance and calculate important average network metrics. This information can quantify the network performance. |
| ARINC 429 transparent service, latency | Acquiring an ARINC 429 compliant sensor(s) and connect it (them) to the demonstrator network. An ARINC 429 data bus will connect the sensor/sensor/controller to an ARINC 429 Access Point node. This test option discussed in section 4.1 will demonstrate that the designed network offers transparent ARINC 429 service. |
| Latency, reliability | Developing software that receives ARINC 429 words and visualizes the data with simple graphics, resembling cockpit displays. This software will be running on a laptop which will be connected to an AFDX Gateway with an Ethernet cable. Satisfying the mock application's performance requirements shows that the network can function as intended and makes the case for wireless technologies. |
| Reliability, tolerance to interference | Configuring the power of transmission in a way that replicates radio interference and other unwanted radio phenomena. Such a test will show that the demonstrator respects the requirements even in non-ideal electromagnetic environments. |
| Reliability | Configuring the control plane to randomly switch certain nodes and links off. This configuration will demonstrate that the applied techniques result in a robust design and can keep functioning even in case of partial failure. |

Table 6: Testing options