

Hearing aid with probabilistic hearing loss compensation

Citation for published version (APA):

de Vries, A., & Farmani, M. (2015). Hearing aid with probabilistic hearing loss compensation. (Patent No. US2015125016).

https://nl.espacenet.com/publicationDetails/biblio?II=0&ND=3&adjacent=true&locale=nl_NL&FT=D&date=20150507&CC=US&NR=2015125016A1&KC=A1#

Document status and date:

Published: 07/05/2015

Document Version:

Publisher's PDF, also known as Version of Record (includes final page, issue and volume numbers)

Please check the document version of this publication:

- A submitted manuscript is the version of the article upon submission and before peer-review. There can be important differences between the submitted version and the official published version of record. People interested in the research are advised to contact the author for the final version of the publication, or visit the DOI to the publisher's website.
- The final author version and the galley proof are versions of the publication after peer review.
- The final published version features the final layout of the paper including the volume, issue and page numbers.

[Link to publication](#)

General rights

Copyright and moral rights for the publications made accessible in the public portal are retained by the authors and/or other copyright owners and it is a condition of accessing publications that users recognise and abide by the legal requirements associated with these rights.

- Users may download and print one copy of any publication from the public portal for the purpose of private study or research.
- You may not further distribute the material or use it for any profit-making activity or commercial gain
- You may freely distribute the URL identifying the publication in the public portal.

If the publication is distributed under the terms of Article 25fa of the Dutch Copyright Act, indicated by the "Taverne" license above, please follow below link for the End User Agreement:

www.tue.nl/taverne

Take down policy

If you believe that this document breaches copyright please contact us at:

openaccess@tue.nl

providing details and we will investigate your claim.



(19) **United States**

(12) **Patent Application Publication**
DE VRIES et al.

(10) **Pub. No.: US 2015/0125016 A1**

(43) **Pub. Date: May 7, 2015**

(54) **HEARING AID WITH PROBABILISTIC HEARING LOSS COMPENSATION**

Publication Classification

(71) Applicant: **GN ReSound A/S, Ballerup (DK)**

(51) **Int. Cl.**
H04R 1/10 (2006.01)
H04R 25/00 (2006.01)

(72) Inventors: **Aalbert DE VRIES, Eindhoven (NL);
Mojtaba FARMANI, Eindhoven (NL)**

(52) **U.S. Cl.**
CPC **H04R 1/1091** (2013.01); **H04R 25/00**
(2013.01)

(73) Assignee: **GN ReSound A/S, Ballerup (DK)**

(57) **ABSTRACT**

(21) Appl. No.: **14/077,031**

A hearing aid includes: an input transducer for provision of an audio signal in response to sound; a hearing loss model for calculation of a hearing loss as a function of a signal level of the audio signal; and a probabilistic hearing loss compensator that is configured to process the audio signal into a hearing loss compensated audio signal in such a way that the hearing loss is restored to normal hearing in accordance with the hearing loss model.

(22) Filed: **Nov. 11, 2013**

(30) **Foreign Application Priority Data**

Nov. 7, 2013 (DK) PA 2013 70656
Nov. 7, 2013 (EP) 13191993.8

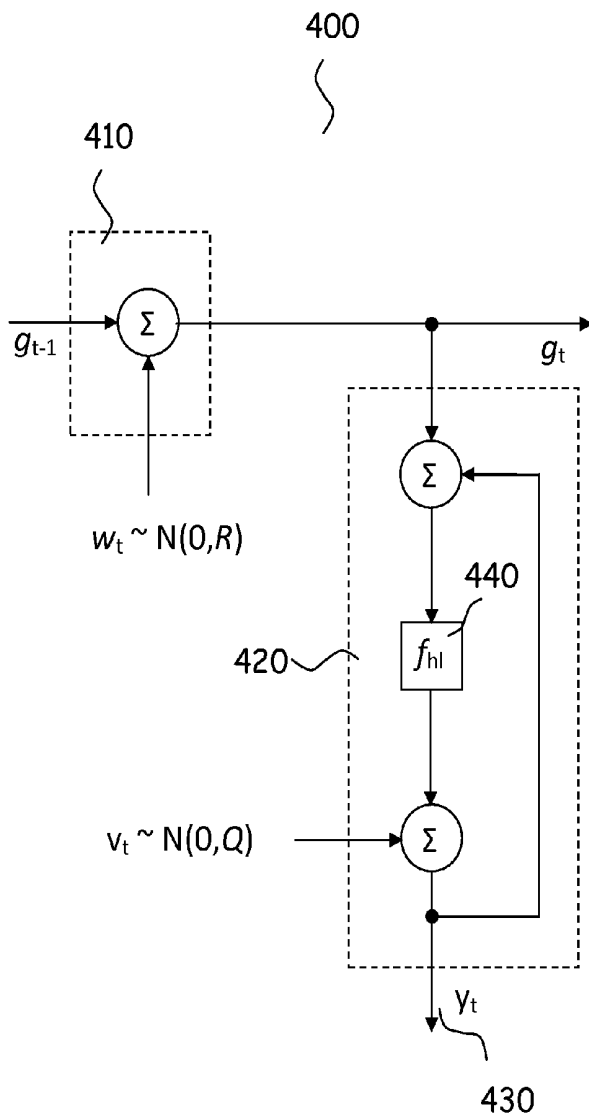

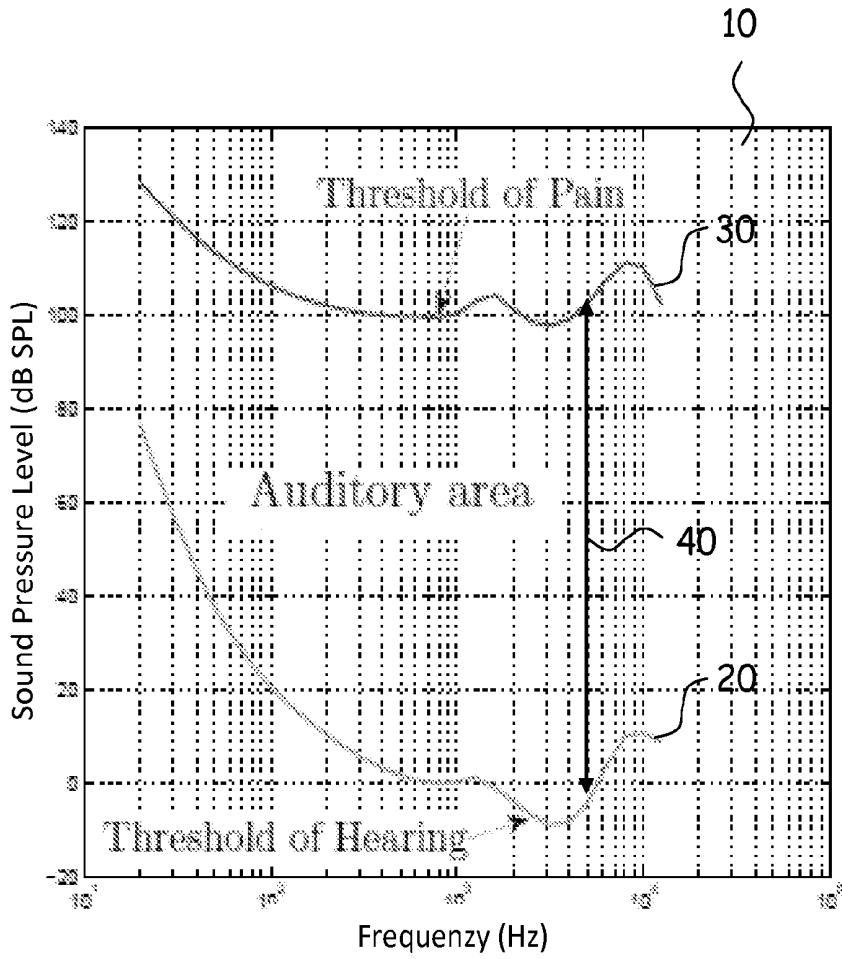

Fig. 1

50

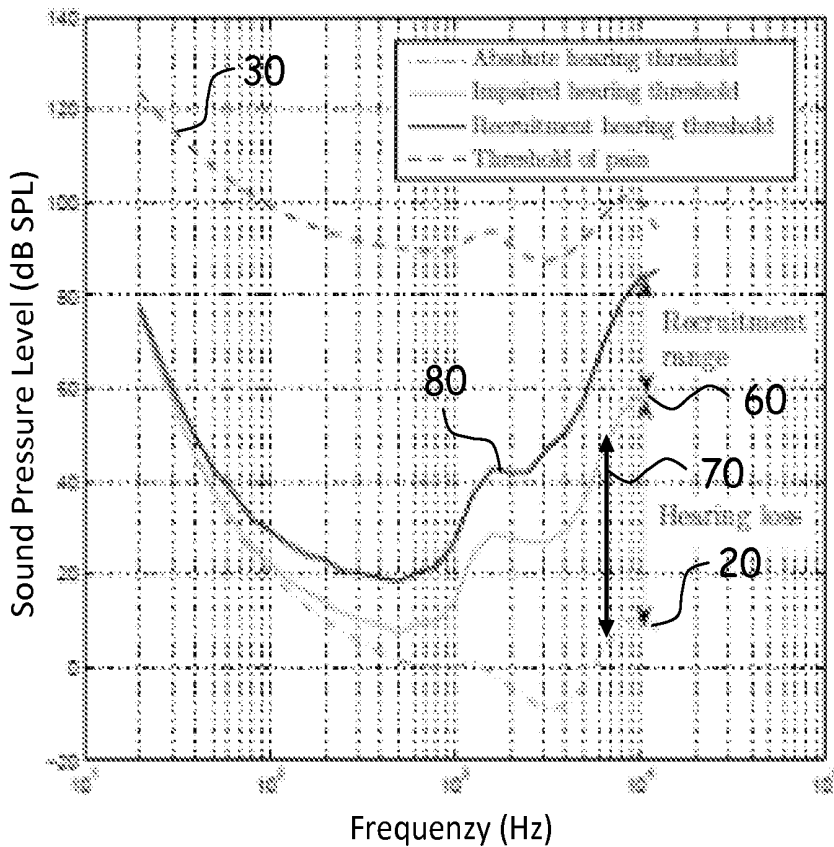

Fig. 2

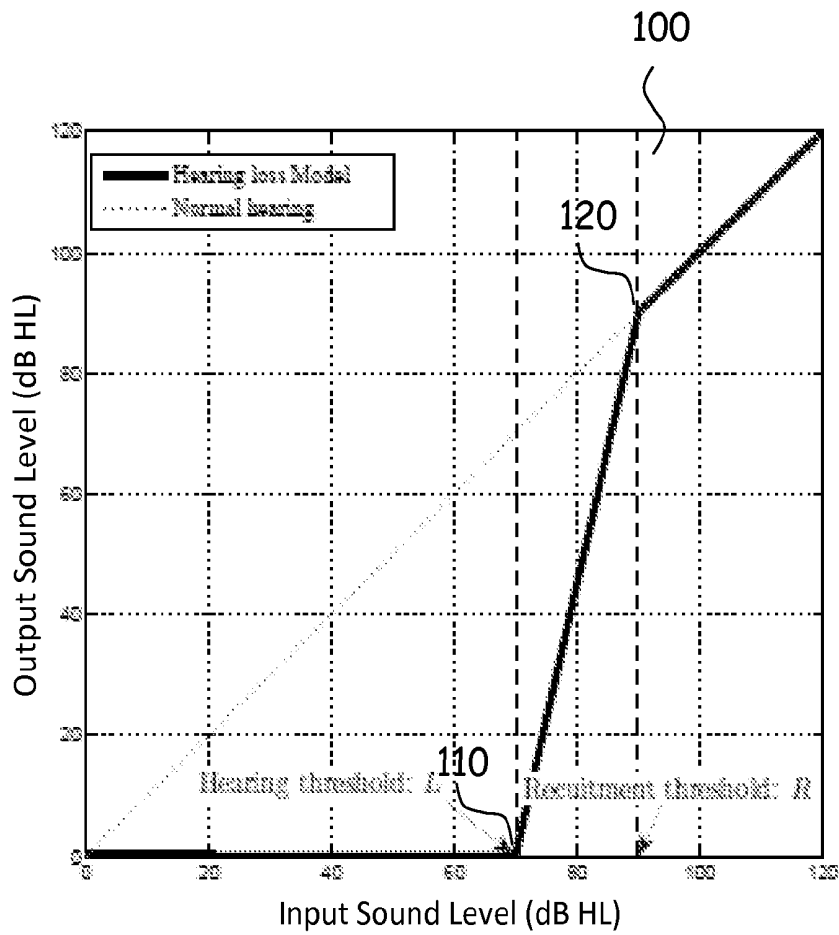

Fig. 3

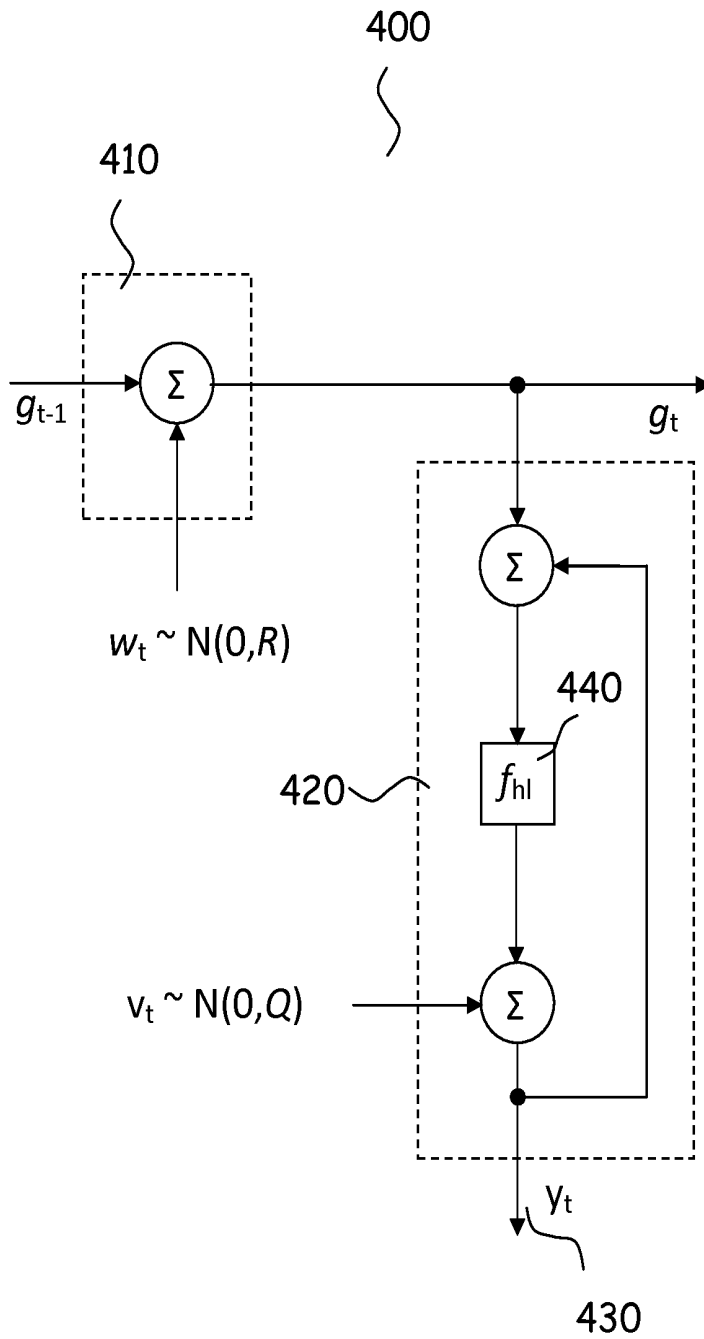

Fig. 4

450

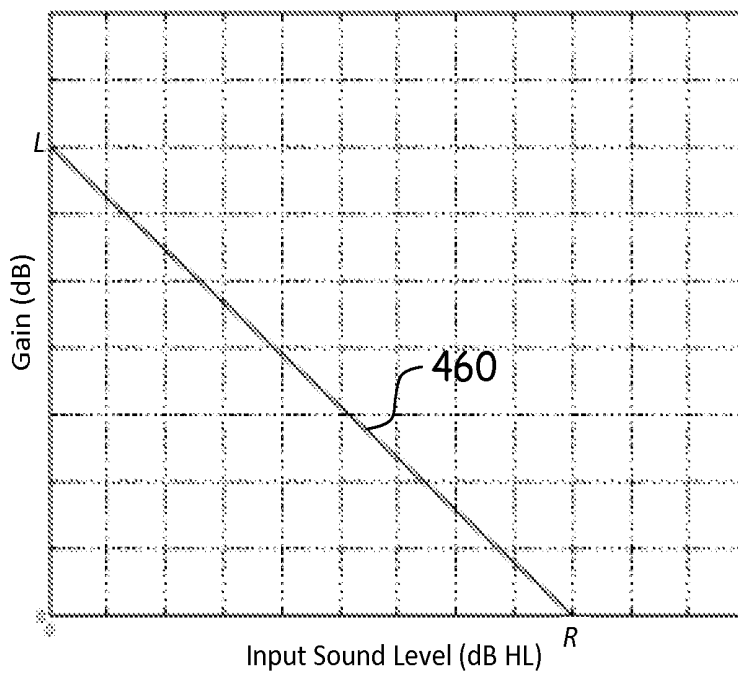

Fig. 5

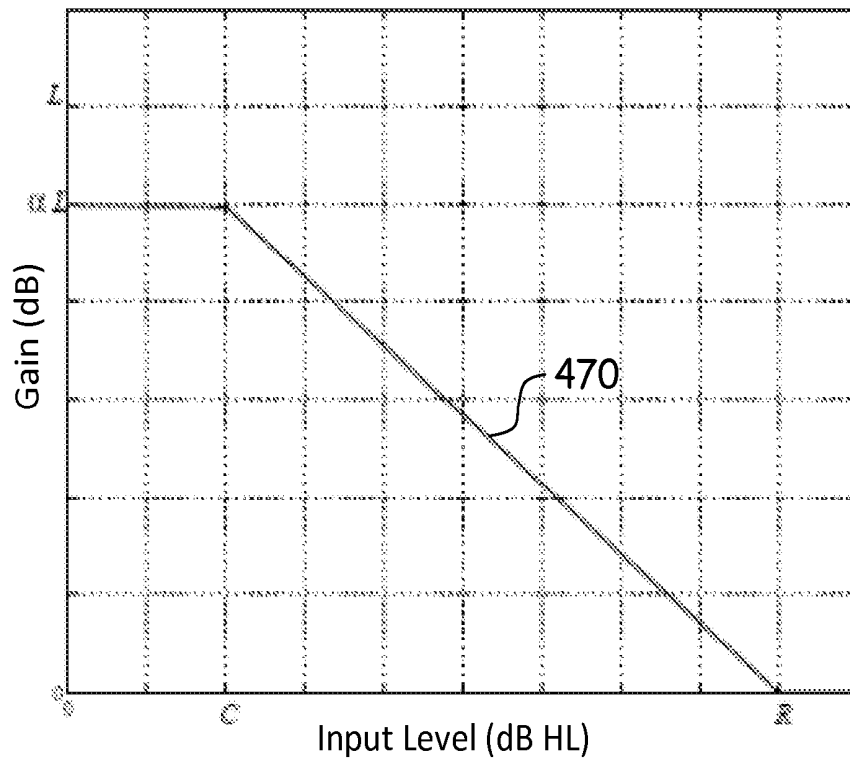

Fig. 6

500

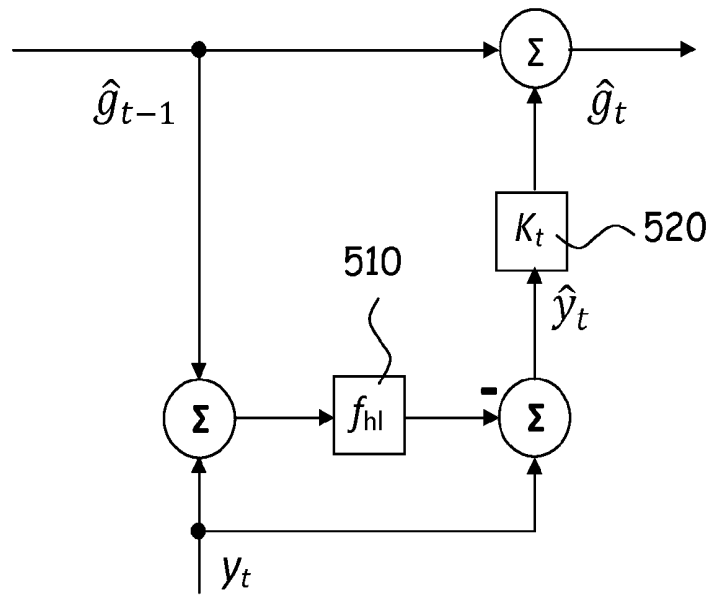

Fig. 7

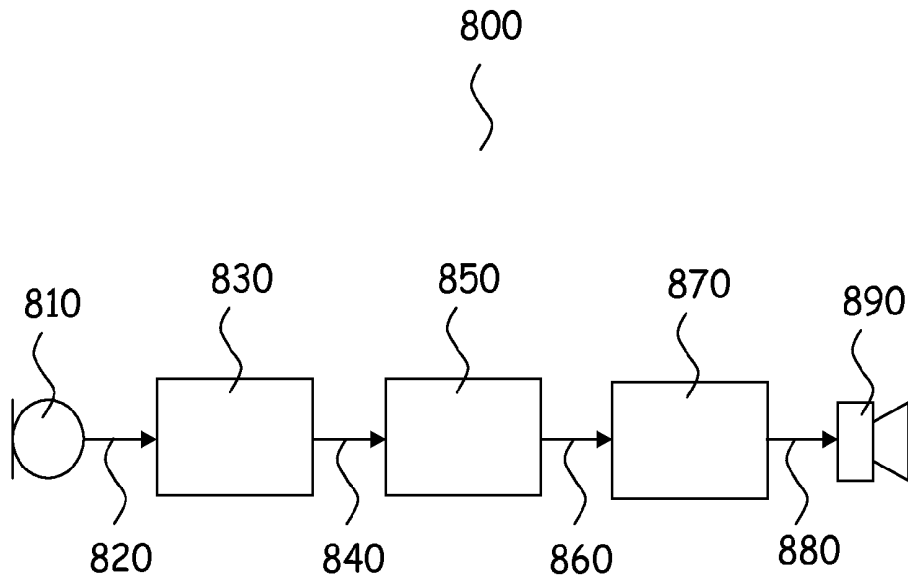

Fig. 8

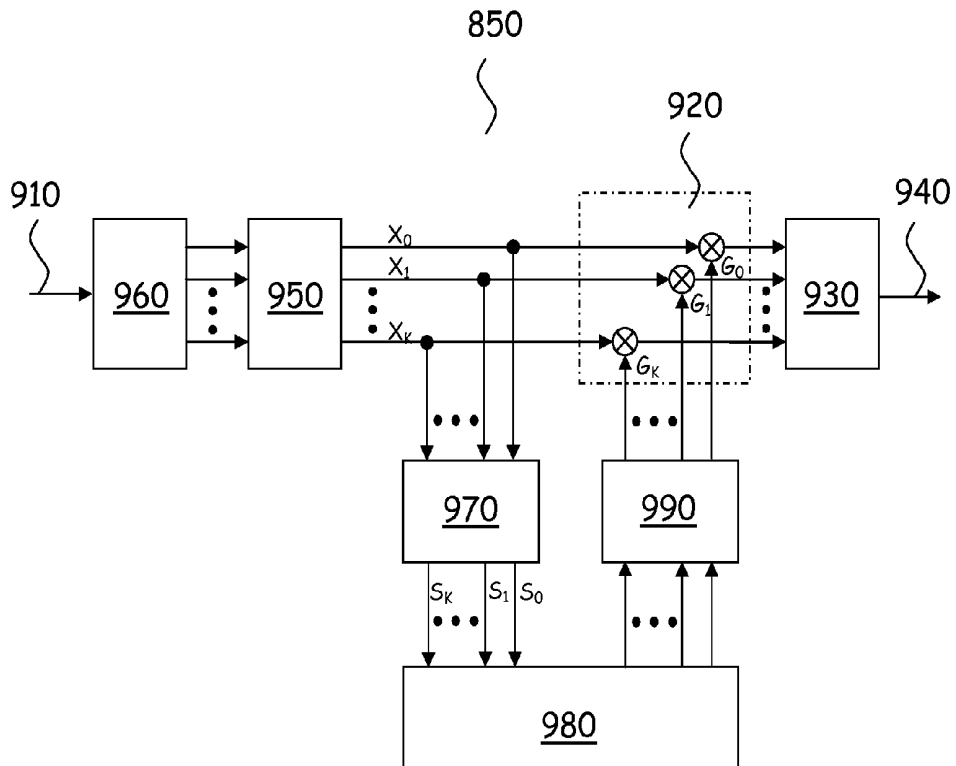

Fig. 9

HEARING AID WITH PROBABILISTIC HEARING LOSS COMPENSATION

RELATED APPLICATION DATA

[0001] This application claims priority to and the benefit of Danish Patent Application No. PA 2013 70656, filed on Nov. 7, 2013, pending, and European Patent Application No. 13191993.8, filed on Nov. 7, 2013, pending. The entire disclosures of the above applications are expressly incorporated by reference herein.

FIELD

[0002] An embodiment described herein relates to a new hearing aid that is configured to perform probabilistic hearing loss compensation in accordance with a predetermined hearing loss model.

BACKGROUND

[0003] There are three main types of hearing loss:

[0004] Conductive hearing loss is present when the outer ear canal to the eardrum and the tiny bones (ossicles) of the middle ear cannot conduct sounds efficiently so that sound is not reaching the inner ear, the cochlea.

[0005] Sensorineural hearing loss is present when the inner ear (cochlea) or the nerve that transmits the impulses from the cochlea to the hearing centre in the brain or in the brain is damaged. The most common reason for sensorineural hearing loss is damage to the hair cells in the cochlea.

[0006] Mixed hearing loss is a combination of the two types of hearing loss discussed above.

[0007] Typically, a hearing impaired human suffering from sensorineural hearing loss experiences a loss of hearing sensitivity that is 1) frequency dependent and 2) dependent upon the loudness of sound at an ear.

[0008] Thus, a hearing impaired human may be able to hear certain frequencies, e.g., low frequencies, as well as a human with normal hearing, while other frequencies are not heard as well. Typically, hearing impaired humans experience loss of hearing sensitivity at high frequencies.

[0009] At frequencies with reduced sensitivity, the hearing impaired human is often able to hear loud sounds as well as the human with normal hearing, but unable to hear soft sounds with the same sensitivity as the human with normal hearing. Thus, the hearing impaired human suffers from a loss of dynamic range.

SUMMARY

[0010] A dynamic range compressor may be used in a hearing aid to compress the dynamic range of sound arriving at an ear of the hearing impaired human to match the residual dynamic range of the human in question. The degree of dynamic hearing loss of the hearing impaired human may be different in different frequency bands.

[0011] The slope of the input-output compressor transfer function is referred to as the compression ratio. The compression ratio required by a human may not be constant over the entire input power range, i.e. typically the compressor characteristic has one or more knee-points.

[0012] Thus, dynamic range compressors may be configured to perform differently in different frequency bands, thereby accounting for the frequency dependence of the hearing loss of the human in question. Such a multiband or multiband compressor divides an input signal into two or more

frequency bands or frequency channels and then compresses each frequency band or channel separately. The parameters of the compressor, such as compression ratio, positions of knee-points, attack time constant, release time constant, etc. may be different for each frequency band.

[0013] Dynamic range compressors are fitted to the hearing loss of the human by adjustment of compressor parameters in accordance with accepted fitting rules and based on hearing thresholds determined for the human.

[0014] The fitting rules may not be motivated by a mathematical or algorithmic description of the hearing loss that the dynamic range compressor is intended to compensate for, so for example, time constants have to be set in accordance with empirical rules.

[0015] In absence of a proper description of the actual hearing loss, performance evaluation of the compressor's hearing loss compensation may be difficult. Indeed comparative evaluation of dynamic range compressor algorithms for hearing loss compensation is almost entirely based on subjective testing.

[0016] There is a need for a new method of hearing loss compensation that is based on proper mathematical descriptions of hearing loss. Such methods can be compared to each other and other methods of hearing loss compensation based on objective measures facilitating progress in hearing loss compensation methods.

[0017] It is an object of the new method of hearing loss compensation to perform probabilistic hearing loss compensation in accordance with a selected hearing loss model.

[0018] According to the new method, an acoustic signal arriving at an ear canal of a hearing impaired human is processed in such a way that the human's auditory system according to the hearing loss model obtains the same listening result as an auditory system of a human with normal hearing.

[0019] Thus, a new method of hearing loss compensation is provided, comprising the steps of

providing an audio signal in response to sound, providing a hearing loss model for calculation of hearing loss as a function of a signal level of the audio signal, probabilistically processing the audio signal into a hearing loss compensated audio signal in such a way that hearing loss is compensated to normal hearing in accordance with the hearing loss model.

[0020] Further, a new hearing aid is provided, comprising an input transducer for provision of an audio signal in response to sound,

a hearing loss model for calculation of a hearing loss as a function of a signal level of the audio signal,

a probabilistic hearing loss compensator that is configured to process the audio signal into a hearing loss compensated audio signal in such a way that the hearing loss is restored to normal hearing in accordance with the hearing loss model, and preferably

an output transducer for conversion of the hearing loss compensated audio signal to an auditory output signal, such as an acoustic output signal, an implanted transducer signal, etc. that can be received by the human auditory system.

[0021] For example, the hearing aid may aim to restore loudness, such that the loudness of the received signal as it is perceived by a normal listener will match the perceived loudness of the processed signal for the hearing impaired listener.

[0022] Likewise, the hearing loss model may model spectral power patterns, speech intelligibility of the hearing impaired human, or quality of music of the hearing impaired

human, or any combination of features of the hearing loss of the hearing impaired human in question.

[0023] The hearing loss model may be a Zurek Model as disclosed in: Patrick M. Zurek and Joseph G. Desloge: "Hearing loss and prosthesis simulation in audiology" *The Hearing Journal*, 60(7), 2007, Brian Moore and Brian Glasberg: "Simulation of the effects of loudness recruitment and threshold elevation of the intelligibility of speech in quiet and in background of speech", *J. Acoust. Soc. Am.*, 94(4), 2050-2062, J. Chalupper and H. Fastl: "Simulation of hearing impairment based on the Fourier time transformation", *Acoustics, Speech, and Signal Processing, ICASSP '00 Proceedings*, 2000, etc.

[0024] The probabilistic compensator may include an algorithm based on Bayesian inference.

[0025] The probabilistic compensator may be a Kalman filter, an Extended Kalman filter, an online variational Bayesian Kalman filter, a particle filter or an Unscented Kalman filter, etc.

[0026] The signal level of the audio signal may be calculated as an average value of the audio signal, such as an rms-value, a mean amplitude value, a peak value, an envelope value, etc.

[0027] Often, the hearing loss of a human varies as a function of frequency. Thus, signal processing according to the new method, e.g. in the new hearing aid, may be performed differently for different frequencies, thereby accounting for the frequency dependence of the hearing loss of the human in question.

[0028] In the new hearing aid, the audio signal may be divided (e.g., using circuitry) into two or more frequency bands or frequency channels, and each frequency band or frequency channel may be processed individually.

[0029] The new hearing aid may form part of a new binaural hearing aid system comprising two hearing aids, one of which is intended for compensation of hearing loss of the left ear of the human and the other of which is intended for compensation of hearing loss of the right ear of the human. Both hearing aids may operate according to the new method.

[0030] The new probabilistic method of hearing loss compensation has the following advantages:

[0031] The predetermined hearing loss model forms part of the signal processing algorithm,

[0032] Automatic inference of the hearing loss compensation gain for any given hearing loss model,

[0033] Proper description of time constants, namely as inverse variances of probability distributions,

[0034] Allows for probabilistic descriptions of the hearing loss model. In principle, hierarchical hearing loss models that relate individual models to 'average group' models are facilitated,

[0035] Learning hearing loss compensation is facilitated, and

[0036] A proper evaluation framework is provided for hearing loss compensation algorithms.

[0037] A transducer is a device that converts a signal in one form of energy to a corresponding signal in another form of energy.

[0038] The input transducer may comprise a microphone that converts an acoustic signal arriving at the microphone into a corresponding analogue audio signal in which the instantaneous voltage of the audio signal varies continuously with the sound pressure of the acoustic signal. Preferably, the input transducer comprises a microphone.

[0039] The input transducer may also comprise a telecoil that converts a magnetic field at the telecoil into a corresponding analogue audio signal in which the instantaneous voltage of the audio signal varies continuously with the magnetic field strength at the telecoil. Telecoils may be used to increase the signal to noise ratio of speech from a speaker addressing a number of people in a public place, e.g. in a church, an auditorium, a theatre, a cinema, etc., or through a public address systems, such as in a railway station, an airport, a shopping mall, etc. Speech from the speaker is converted to a magnetic field with an induction loop system (also called "hearing loop"), and the telecoil is used to magnetically pick up the magnetically transmitted speech signal.

[0040] The input transducer may further comprise at least two spaced apart microphones, and a beamformer configured for combining microphone output signals of the at least two spaced apart microphones into a directional microphone signal.

[0041] The input transducer may comprise one or more microphones and a telecoil and a switch, e.g. for selection of an omni-directional microphone signal, or a directional microphone signal, or a telecoil signal, either alone or in any combination, as the audio signal.

[0042] Typically, the analogue audio signal is made suitable for digital signal processing by conversion into a corresponding digital audio signal in an analogue-to-digital converter whereby the amplitude of the analogue audio signal is represented by a binary number. In this way, a discrete-time and discrete-amplitude digital audio signal in the form of a sequence of digital values represents the continuous-time and continuous-amplitude analogue audio signal.

[0043] Throughout the present disclosure, the "audio signal" may be used to identify any analogue or digital signal forming part of the signal path from the output of the input transducer to an input of the processor.

[0044] Throughout the present disclosure, the "hearing loss compensated audio signal" may be used to identify any analogue or digital signal forming part of the signal path from the output of the signal processor to an input of the output transducer.

[0045] Signal processing in the new hearing aid may be performed by dedicated hardware or may be performed in one or more signal processors, or performed in a combination of dedicated hardware and one or more signal processors.

[0046] As used herein, the terms "processor", "signal processor", "controller", "system", etc., are intended to refer to CPU-related entities, either hardware, a combination of hardware and software, software, or software in execution.

[0047] For example, a "processor", "signal processor", "controller", "system", etc., may be, but is not limited to being, a process running on a processor, a processor, an object, an executable file, a thread of execution, and/or a program.

[0048] By way of illustration, the terms "processor", "signal processor", "controller", "system", etc., designate both an application running on a processor and a hardware processor. One or more "processors", "signal processors", "controllers", "systems" and the like, or any combination hereof, may reside within a process and/or thread of execution, and one or more "processors", "signal processors", "controllers", "systems", etc., or any combination hereof, may be localized on one hardware processor, possibly in combination with other hard-

ware circuitry, and/or distributed between two or more hardware processors, possibly in combination with other hardware circuitry.

[0049] Also, a processor (or similar terms) may be any component or any combination of components that is capable of performing signal processing. For examples, the signal processor may be an ASIC processor, a FPGA processor, a general purpose processor, a microprocessor, a circuit component, or an integrated circuit.

[0050] A hearing aid includes: an input transducer for provision of an audio signal in response to sound; a hearing loss model for calculation of a hearing loss as a function of a signal level of the audio signal; and a probabilistic hearing loss compensator that is configured to process the audio signal into a hearing loss compensated audio signal in such a way that the hearing loss is restored to normal hearing in accordance with the hearing loss model.

[0051] Optionally, the hearing loss relates to at least one of spectral power, loudness, speech reception threshold, and quality of music.

[0052] Optionally, the probabilistic hearing loss compensator is configured to operate based on Bayesian inference.

[0053] Optionally, the probabilistic hearing loss compensator comprises a Kalman filter, an Extended Kalman filter, an online variational Bayesian Kalman filter, an Unscented Kalman filter, or a particle filter.

[0054] Optionally, the hearing loss model is based on a Zurek model.

[0055] Optionally, the signal level of the audio signal comprises an average value of the audio signal, a rms-value of the audio signal, a mean amplitude value of the audio signal, a peak value of the audio signal, or an envelope value of the audio signal.

[0056] Optionally, the probabilistic hearing loss compensator is configured to determine a gain using a recursive technique.

[0057] Optionally, the probabilistic hearing loss compensator is configured to determine the gain based on the hearing loss model.

[0058] Optionally, the probabilistic hearing loss compensator is configured to determine the gain using Kalman filtering principle that comprises the recursive technique.

[0059] A method of hearing loss compensation includes: providing an audio signal in response to sound; providing a hearing loss model for calculation of hearing loss as a function of a signal level of the audio signal; and probabilistically processing the audio signal into a hearing loss compensated audio signal in such a way that the hearing loss is restored to normal hearing in accordance with the hearing loss model.

[0060] Optionally, the hearing loss relates to at least one of spectral power, loudness, speech reception threshold, and quality of music.

[0061] Optionally, the probabilistically processing is performed based on Bayesian inference.

[0062] Optionally, the probabilistically processing is performed using a probabilistic compensator, the probabilistic compensator being a Kalman filter, an Extended Kalman filter, an online variational Bayesian Kalman filter, an Unscented Kalman filter, or a particle filter.

[0063] Optionally, the probabilistically processing comprises determining a gain using a recursive technique.

[0064] Optionally, the probabilistically processing comprises determining the gain using Kalman filtering principle that comprises the recursive technique.

[0065] Other and further aspects and features will be evident from reading the following detailed description.

BRIEF DESCRIPTION OF THE FIGURES

[0066] The drawings illustrate the design and utility of embodiments, in which similar elements are referred to by common reference numerals. These drawings may or may not be drawn to scale. In order to better appreciate how the above-recited and other advantages and objects are obtained, a more particular description of the embodiments will be rendered, which are illustrated in the accompanying drawings. These drawings depict only exemplary embodiments and are not therefore to be considered limiting in the scope of the claims.

[0067] In the following, the new method and hearing aid is explained in more detail with reference to the drawings, wherein

[0068] FIG. 1 shows a plot of human normal hearing auditory threshold levels as a function of frequency,

[0069] FIG. 2 shows an exemplary plot of human hearing loss thresholds and recruitment threshold as a function of frequency,

[0070] FIG. 3 shows a plot of input-output transfer function of a Zurek hearing loss model,

[0071] FIG. 4 shows a block diagram of a probabilistic prediction model,

[0072] FIG. 5 shows a plot of gain calculations based on the Zurek hearing loss model,

[0073] FIG. 6 shows a plot of gain calculations based on a modified Zurek hearing loss model,

[0074] FIG. 7 shows a block diagram of a probabilistic hearing loss compensator,

[0075] FIG. 8 shows a block diagram of a hearing aid operating according to the new method, and

[0076] FIG. 9 shows a block diagram of a hearing aid with a probabilistic hearing loss compensator.

DETAILED DESCRIPTION

[0077] Various embodiments are described hereinafter with reference to the figures. It should also be noted that the figures are only intended to facilitate the description of the embodiments. They are not intended as an exhaustive description of the invention or as a limitation on the scope of the invention. In addition, an illustrated embodiment needs not have all the aspects or advantages shown. An aspect or an advantage described in conjunction with a particular embodiment is not necessarily limited to that embodiment and can be practiced in any other embodiments even if not so illustrated.

[0078] In the following, various examples of the new method and hearing aid are illustrated. The new method and hearing aid according to the appended claims may, however, be embodied in different forms and should not be construed as limited to the examples set forth herein.

The Hearing Loss Model

[0079] FIG. 1 shows a plot 10 of human normal hearing auditory threshold levels as a function of frequency. Humans are able to hear sounds in the frequency range from about 20 Hz to about 20 kHz.

[0080] The lower curve 20 shows the hearing threshold, i.e. the lowest sound pressure levels the human auditory system can detect. Sound pressure levels below the lower curve cannot be heard by a human with normal hearing.

[0081] The upper curve **30** shows the upper comfort level or pain threshold, i.e. the highest sound pressure levels the human can listen to without feeling pain or discomfort.

[0082] The range between the hearing threshold **20** and the pain threshold **30** is the dynamic range of normal hearing **40** that varies as a function of frequency.

[0083] Different hearing loss models may be provided for the respective types of hearing loss.

[0084] For ease of understanding, in the following, the new method of hearing loss compensation is disclosed with relation to a particular hearing loss model, namely the hearing loss model proposed by Patrick M Zurek and Joseph G Desloge: "Hearing loss and prosthesis simulation in audiology", The Hearing Journal, 60(7), 2007, in the following denoted the Zurek model. However, obviously other models of hearing loss may substitute the Zurek model in the new method.

[0085] FIG. 2 illustrates a hearing loss modelled by the Zurek model. FIG. 2 shows a plot **50** of four hearing auditory threshold levels as a function of frequency. The thresholds of normal hearing shown in FIG. 1 are plotted as dashed curves **20**, **30** in FIG. 2. The second lower most curve **60** is the hearing threshold of a hearing impaired human. The hearing impaired human cannot hear sounds below the second lower most curve **60**. The range between the lower most and the second lower most curves **20**, **60** represents the lost dynamic range **70** of the hearing impaired human.

[0086] The second upper most curve **80** is the recruitment threshold. The hearing impaired human hears sounds above the recruitment threshold **80** as with normal hearing.

[0087] FIG. 3 shows a plot **100** of input-output transfer function of a corresponding Zurek hearing loss model in a specific frequency band with a hearing threshold **110** of L=70 dB HL and a recruitment threshold **120** of R=90 dB HL.

[0088] According to this hearing loss model, the hearing sensation level f, i.e. the sound level in dB relative to the hearing threshold, is given by:

$$f_{Zurek}(x) = \begin{cases} 0 & x < L \\ \frac{R}{R-L}(x-L) & L \leq x \leq R \\ x & x > R \end{cases} \quad (1)$$

wherein x is the input sound level in dB HL.

Probabilistic Hearing Loss Compensator

[0089] In the following, the new method of hearing loss compensation is disclosed with relation to loudness restoration; however, obviously hearing loss may be characterized otherwise, e.g. by speech reception threshold, combinations of loudness and speech reception threshold, etc. to be restored to normal hearing, whereby the human's auditory system according to the selected hearing loss model obtains the same listening result as an auditory system of a human with normal hearing.

[0090] For loudness restoration with any model of hearing loss, in a frequency band ω , it is desired to apply a gain g_ω to the input signal so that loudness as perceived by the hearing impaired human is restored to the loudness as perceived by a normal hearing human:

$$f_{HL}(y_\omega + g_\omega) \sim y_\omega \quad (2)$$

where

y_ω is the audio signal level in dB in the frequency band ω ,
 g_ω is the estimated gain in dB in the frequency band ω , and
 $f_{HL}(\cdot)$ is the hearing loss model.

[0091] For simplicity, the frequency band suffix ω is omitted in the equations below.

[0092] FIG. 4 illustrates a block diagram of a prediction model **400** formed in accordance with the new method. The illustrated prediction model **400** has a state transition part **410** and an observation part **420**, and it calculates the gain based on the audio signal level y_t , **430** and a human's hearing model f_{HL} **440**.

[0093] FIG. 4 illustrates processing in a single frequency band or channel. The illustrated single frequency band may constitute the entire frequency band of a single band probabilistic hearing loss compensator; or, the illustrated single frequency band may constitute one individual frequency band of a plurality of frequency bands of a multiband probabilistic hearing loss compensator.

[0094] Rapidly changing gain has unfavourable effects on the sound quality and is therefore not desired.

[0095] The prediction model is defined accordingly:

$$g_t = g_{t-1} + w_t \quad (3)$$

where t is the discrete time index, g is the provided gain in dB, and w_t is the process noise which is modelled by a white Gaussian noise— $w_t \sim N(0, St)$, where St is the (possibly time-varying) variance of the process noise.

[0096] The estimated gain g_t is updated based on an observation model. As mentioned above with relation to equation (1), the hearing-impaired human is desired to perceive loudness similar to a normal-hearing human.

[0097] Therefore, the difference between $f_{HL}(y_t + g_t)$ and y_t is observed as a zero-mean noise process:

$$v_t = f_{HL}(y_t + g_t) + v_t \quad (4)$$

where v_t is the observation noise which is modelled by a white Gaussian noise— $v_t \sim N(0, Qt)$, where Qt is the (possibly time-varying) variance of the observation noise modelling uncertainties relating to the hearing loss model.

[0098] As an example, we compute the steady state gain as a function of the input power for Zurek's hearing loss model. Equation (2) is applied to the Zurek hearing loss model:

$$f_{Zurek}(y+g) = y \rightarrow \quad (5)$$

$$g = f_{Zurek}^{-1}(y) - y \quad (6)$$

[0099] In the Zurek model, see FIG. 3, in order to restore loudness to that of normal hearing, sounds with sound levels between the normal hearing threshold and the recruitment threshold have to be compressed into sound levels between the impaired hearing threshold and the recruitment threshold.

[0100] When $x \geq L$, the Zurek's model $f_{Zurek}(x)$ is a one-to-one function, and $f_{Zurek}(x) \geq 0$.

[0101] Thus, for $x \geq L$:

$$f_{Zurek}^{-1}(x) = \begin{cases} \frac{R-L}{R}x + L & 0 \leq x \leq R \\ x & x > R \end{cases} \quad (7)$$

And

$$g_{steady_state} = \begin{cases} \frac{R-L}{R}x + L - x & 0 \leq x \leq R \\ 0 & x > R \end{cases} \quad (8)$$

where x is the sound level in dB HL; L is the human's hearing threshold, and R is the human's recruitment threshold in dB HL.

[0102] FIG. 5 is a plot **450** of the gain vs. input curve of the steady-state gain based on the Zurek's hearing loss model. It

is shown that the gain 460 required for restoring normal loudness perception, decreases linearly as a function of the hearing level (dB HL) from L dB at 0 dB hearing level to 0 dB at recruitment threshold R. The compression threshold is 0 dB HL and the compression ratio is $R/(R-L)$.

[0103] According to Zurek's hearing loss model, the human can hear almost like a normal-hearing human when the input sound hearing level is larger than the recruitment threshold R and thus, the provided gain above the recruitment threshold should be 0 dB.

[0104] The gain-input curve 460 shown in FIG. 5 restores loudness to normal in accordance with Zurek's hearing loss model, but in practise, the large gain at low signals is likely to cause feedback and also amplifies noise that the human does not want to hear. Also large gain variations are likely to be experienced at low signal levels that undesirably distort the signal waveform.

[0105] Therefore, it is preferred to modify the gain-input curve 460 of FIG. 5 into the gain-input curve 200 shown in FIG. 6 wherein the gain is kept constant at αL dB below a selected compression threshold C.

[0106] The compression threshold C may be determined during fitting of the hearing aid to the human.

[0107] The gain-input curve 470 shown in FIG. 6 is given by:

$$g = \begin{cases} \alpha L & x < C \\ \frac{-\alpha L}{R-C}(x-R) & C \leq x \leq R \\ 0 & x > R \end{cases} \quad (9)$$

wherein x is the input signal level in dB HL.

[0108] Equation (9) is inserted into equation (2), whereby

$$f_L(x) = \begin{cases} x - \alpha L & x < C + \alpha L \\ \frac{R-C}{R-(C+\alpha L)}(x-R) + R & C + \alpha L \leq x \leq R \\ x & x > R \end{cases} \quad (10)$$

where x is the input sound level in dB HL. L and R represent the hearing threshold and the recruitment threshold of the human in dB HL, respectively. $\alpha \in [0, 1]$, and C is the compression threshold in dB HL, and

$$\frac{R-C}{R-(C+\alpha L)}$$

is the compression ratio of the model.

Probabilistic Hearing Loss Compensator

[0109] FIG. 7 shows a block diagram of a probabilistic hearing loss compensator 500 that operates in accordance with the new method.

[0110] FIG. 7 illustrates processing in a single frequency band or channel ω . The illustrated single frequency band ω may constitute the entire frequency band of a single band probabilistic hearing loss compensator; or, the illustrated single frequency band ω may constitute one individual frequency band of a plurality of frequency bands of a multiband probabilistic hearing loss compensator.

[0111] In a multiband probabilistic hearing loss compensator, the frequency bands ω may have the same bandwidth, or, some or all of the frequency bands may have different bandwidths. Varying bandwidths may for example result from frequency warping.

[0112] The illustrated probabilistic hearing loss compensator has a hearing loss model f_{hl} 510 and an Extended Kalman filter K_t 520 for determination of the gain applied in the respective frequency band ω .

[0113] In the following, the system is assumed to constitute a dynamic system perturbed by Gaussian noise; however it should be noted that any type of Kalman filter may be used as K_t 520 in FIG. 7, such as a Kalman filter, an Extended Kalman filter, an online variational Bayesian Kalman filter, an Unscented Kalman filter or a particle filter, etc, reference is made to the extensive literature on Kalman filters.

[0114] Likewise, the Zurek model is used in the illustrated example; however it should be noted that any hearing loss model may be used as the hearing loss model f_{hl} 510 in FIG. 7.

[0115] In order to infer the time-varying gain g_t in the selected frequency band, we first describe the problem by a generative probabilistic model:

$$\begin{aligned} g_t &= g_{t-1} + w_t, \\ y_t &= f_{hl}(y_t + g_t) + v_t, \\ w_t &\sim \mathcal{N}(0, s_t), \\ v_t &\sim \mathcal{N}(0, Q_t) \end{aligned}$$

[0116] Wherein g_t is the gain compensating the hearing loss in accordance with the hearing loss model f_{hl} 510, y_t is the input signal level in dB SPL, w_t is the system noise, and v_t is the observation noise.

[0117] The generative model can be inverted through Bayesian reasoning. In the case that model f_{hl} is a nonlinear model, Bayesian inference by an Extended Kalman filter leads to the following equations:

$$\begin{aligned} F_t &= \frac{\partial f_{hl}}{\partial g} \Big|_{\hat{g}_t^-, y_t} \\ \hat{g}_t^- &= \hat{g}_{t-1} \\ P_t^- &= P_{t-1} + Q_t \\ \hat{y}_t &= y_t - f_{hl}(\hat{g}_t^- + y_t) \\ K_t &= P_t^- F_t^T (F_t P_t^- F_t^T + S_t)^{-1} \\ \hat{g}_t &= \hat{g}_t^- + K_t \hat{y}_t \\ P_t &= (I - K_t F_t) P_t^- \end{aligned}$$

[0118] In another example and under the assumption that the system is a linear dynamic system perturbed with Gaussian noise, a regular Kalman filter may update the gain. In that case, F_t would refer to the linear transfer function of the hearing loss model.

[0119] FIG. 8 is a simplified block diagram of a new digital hearing aid 800 operating according to the new method of hearing loss compensation. The hearing aid 800 comprises an input transducer 810, preferably a microphone, for provision of an audio signal 820 input to an analogue-to-digital (A/D) converter 830 for provision of a digital audio signal 840 in response to sound signals received at the input transducer 810, a signal processor 850, e.g. a digital signal processor or DSP, that is configured to process the digital audio signal 840

in accordance with the new method of hearing loss compensation into a hearing loss compensated output signal **860**, a digital-to-analogue (D/A) converter **870** for conversion of the digital signal **860** into a corresponding analogue output signal **880**, and an output transducer **890**, preferably a receiver **890**, for conversion of the analogue output signal **880** into an acoustic output signal for transmission towards an eardrum of the human.

[0120] FIG. 9 shows parts of the signal processor **850** in more detail, namely an exemplary multiband probabilistic hearing loss compensator **850**. In the illustrated example, the multiband probabilistic hearing loss compensator **850** has $K+1$ frequency bands, and K may be any integer larger than or equal to 1.

[0121] The illustrated multiband probabilistic hearing loss compensator **850** has a digital input for receiving a digital input signal **910** from the A/D converter **830**, and a multiband amplifier **920** that performs compensation for frequency dependent hearing loss. The multiband amplifier **920** applies appropriate gains G_0, G_1, \dots, G_K to the respective signals X_0, X_1, \dots, X_K in each of its frequency bands $0, 1, \dots, K$ for compensation of frequency dependent hearing loss. The amplified signals $G_0X_0, G_1X_1, \dots, G_KX_K$ of each frequency band are added together in adder **930** to form the output signal **940**.

[0122] In general, the probabilistic hearing loss compensation may take place individually in different frequency bands. Various probabilistic hearing loss compensators may have different number of frequency bands and/or frequency bands with different bandwidths and/or crossover frequencies.

[0123] The multiband probabilistic hearing loss compensator **850** illustrated in FIG. 9 is a warped multiband probabilistic hearing loss compensator **850** that divides the digital input signal into warped frequency bands $0, 1, 2, \dots, K$.

[0124] A non-warped FFT **950** operates on a tapped delay line **960** with first order all-pass filters providing frequency warping enabling adjustment of crossover frequencies, which are adjusted to provide the desired response in accordance with the humans hearing impairment.

[0125] The multiband probabilistic hearing loss compensator **850** further comprises a multiband signal level detector **970** for individual determination of the signal level S_0, S_1, \dots, S_K of each respective frequency band signal X_0, X_1, \dots, X_K . The outputs S_0, S_1, \dots, S_K of the signal level detectors **970** are provided to the respective Kalman filters **580** of the probabilistic hearing loss compensator **850** as shown in more detail in FIGS. 6 and 8 for determination of probabilistic hearing loss compensating band gains G_0, G_1, \dots, G_K to be applied by the multiband amplifier **920** to the signals X_0, X_1, \dots, X_K of the respective frequency bands.

[0126] The multiband signal level detector **970** calculates an average value of the audio signal in each warped frequency band, such as an rms-value, a mean amplitude value, a peak value, an envelope value, e.g. as determined by a peak detector, etc.

[0127] The multiband signal level detector **970** may calculate running average values of the audio signal; or operate on block of samples. Preferably, the multiband signal level detector operates on blocks of samples whereby required processor power is lowered.

[0128] The probabilistic hearing loss compensator gain outputs G_0, G_1, \dots, G_K are calculated and applied batch-wise for a block of samples whereby required processor power is diminished. When the probabilistic hearing loss compensator operates on blocks of signal samples, the probabilistic hearing loss compensator gain control unit **980** operates at a lower sample frequency than other parts of the system. This means

that the probabilistic hearing loss compensator gains only change every N 'th sample where N is the number of samples in the block. Probable artefacts caused by fast changing gain values are suppressed by low-pass filters **990** at the gain outputs of the probabilistic hearing loss compensator gain control unit **980** for smoothing gain changes at block boundaries.

[0129] Although particular embodiments have been shown and described, it will be understood that they are not intended to limit the claimed inventions, and it will be obvious to those skilled in the art that various changes and modifications may be made without departure from the spirit and scope of the claimed inventions. The specification and drawings are, accordingly, to be regarded in an illustrative rather than restrictive sense. The claimed inventions are intended to cover alternatives, modifications, and equivalents.

We claim:

1. A hearing aid comprising:

an input transducer for provision of an audio signal in response to sound;
a hearing loss model for calculation of a hearing loss as a function of a signal level of the audio signal; and
a probabilistic hearing loss compensator that is configured to process the audio signal into a hearing loss compensated audio signal in such a way that the hearing loss is restored to normal hearing in accordance with the hearing loss model.

2. The hearing aid according to claim 1, wherein the hearing loss relates to at least one of spectral power, loudness, speech reception threshold, and quality of music.

3. The hearing aid according to claim 1, wherein the probabilistic hearing loss compensator is configured to operate based on Bayesian inference.

4. The hearing aid according to claim 1, wherein the probabilistic hearing loss compensator comprises a Kalman filter, an Extended Kalman filter, an online variational Bayesian Kalman filter, an Unscented Kalman filter, or a particle filter.

5. The hearing aid according to claim 1, wherein the hearing loss model is based on a Zurek model.

6. The hearing aid according to claim 1, wherein the signal level of the audio signal comprises an average value of the audio signal, a rms-value of the audio signal, a mean amplitude value of the audio signal, a peak value of the audio signal, or an envelope value of the audio signal.

7. The hearing aid according to claim 1, wherein the probabilistic hearing loss compensator is configured to determine a gain using a recursive technique.

8. The hearing aid according to claim 7, wherein the probabilistic hearing loss compensator is configured to determine the gain based on the hearing loss model.

9. The hearing aid according to claim 7, wherein the probabilistic hearing loss compensator is configured to determine the gain using Kalman filtering principle that comprises the recursive technique.

10. A method of hearing loss compensation comprising:

providing an audio signal in response to sound;
providing a hearing loss model for calculation of hearing loss as a function of a signal level of the audio signal; and
probabilistically processing the audio signal into a hearing loss compensated audio signal in such a way that the hearing loss is restored to normal hearing in accordance with the hearing loss model.

11. The method according to claim 10, wherein the hearing loss relates to at least one of spectral power, loudness, speech reception threshold, and quality of music.

12. The method according to claim **10**, wherein the probabilistically processing is performed based on Bayesian inference.

13. The method according to claim **10**, wherein the probabilistically processing is performed using a probabilistic compensator, the probabilistic compensator being a Kalman filter, an Extended Kalman filter, an online variational Bayesian Kalman filter, an Unscented Kalman filter, or a particle filter.

14. The method according to claim **10**, wherein the probabilistically processing comprises determining a gain using a recursive technique.

15. The method according to claim **14**, wherein the probabilistically processing comprises determining the gain using Kalman filtering principle that comprises the recursive technique.

* * * * *