

Environmental impact assessment of building integrated photovoltaics

Citation for published version (APA):

Ritzen, M. J. (2017). *Environmental impact assessment of building integrated photovoltaics: numerical and experimental carrying capacity based approach*. [Phd Thesis 1 (Research TU/e / Graduation TU/e), Built Environment]. Technische Universiteit Eindhoven.

Document status and date:

Published: 12/10/2017

Document Version:

Publisher's PDF, also known as Version of Record (includes final page, issue and volume numbers)

Please check the document version of this publication:

- A submitted manuscript is the version of the article upon submission and before peer-review. There can be important differences between the submitted version and the official published version of record. People interested in the research are advised to contact the author for the final version of the publication, or visit the DOI to the publisher's website.
- The final author version and the galley proof are versions of the publication after peer review.
- The final published version features the final layout of the paper including the volume, issue and page numbers.

[Link to publication](#)

General rights

Copyright and moral rights for the publications made accessible in the public portal are retained by the authors and/or other copyright owners and it is a condition of accessing publications that users recognise and abide by the legal requirements associated with these rights.

- Users may download and print one copy of any publication from the public portal for the purpose of private study or research.
- You may not further distribute the material or use it for any profit-making activity or commercial gain
- You may freely distribute the URL identifying the publication in the public portal.

If the publication is distributed under the terms of Article 25fa of the Dutch Copyright Act, indicated by the "Taverne" license above, please follow below link for the End User Agreement:

www.tue.nl/taverne

Take down policy

If you believe that this document breaches copyright please contact us at:

openaccess@tue.nl

providing details and we will investigate your claim.

Environmental impact assessment of Building Integrated Photovoltaics

numerical and experimental carrying capacity
based approach



Michiel Ritzen

/ Department of the Built Environment

bouwstenen

230

Environmental impact assessment of Building Integrated Photovoltaics

numerical and experimental carrying capacity based approach

PROEFSCHRIFT

ter verkrijging van de graad van doctor aan de Technische Universiteit Eindhoven,
op gezag van de rector magnificus prof.dr.ir. F.P.T. Baaijens,
voor een commissie aangewezen door het College voor Promoties, in het openbaar
te verdedigen op donderdag 12 oktober 2017 om 16:00 uur

door

Michiel Joep Ritzen

geboren te Delft

Dit proefschrift is goedgekeurd door de promotoren en de samenstelling van de promotiecommissie is als volgt:

voorzitter: prof.ir. E.S.M. Nelissen
1^e promotor: prof.dr.ir. B. Blocken
co-promotor(en): dr.ir. C.P.W. Geurts (TNO, Delft)
dr.ir. Z.A.E.P. Vroon (Zuyd Hogeschool, Heerlen)
leden: prof.dr.ir. A.A.J.F. van den Dobbelsteen (Technische Universiteit,
Delft)
prof.dr.ir. J.L.M. Hensen
prof.dr.ir. G.P.J. Verbong
ir. R. Rovers (SBS centre, Waalre)

Het onderzoek dat in dit proefschrift wordt beschreven is uitgevoerd in overeenstemming met de TU/e Gedragscode Wetenschapsbeoefening.

© Michiel Ritzen, 2017

All rights reserved. No part of this publication may be reproduced, distributed, or transmitted in any form or by any means, including photocopying, recording, or other electronic or mechanical methods, without the prior written permission of the author.

A catalogue record is available from the Eindhoven University of Technology Library.
ISBN: 978 94 6159 751 9
NUR: 955

Published under Bouwstenen series 230 of the Department of the Built Environment, Eindhoven University of Technology.

Printed by Datawyse, the Netherlands.

The research reported in this thesis was supported by Zuyd University of Applied Sciences / De Wijk van Morgen, and funded by the Netherlands Organisation for Scientific Research (NWO), project number 023.001.198, and by the Foundation Innovation Alliance (SIA), project number PRO-2-015 IMDEP and IMDEP Top-up.

Contents

Summary	9
Chapter 1 Introduction	13
Chapter 2 Making the assessment right, or making the right assessment?	31
Chapter 3 Comparison and development of sustainable office façade renovation solutions in the Netherlands	47
Chapter 4 Environmental impact evaluation of energy saving and energy generation: case study for two Dutch dwelling types.	69
Chapter 5 Building Integrated Photovoltaics	95
Chapter 6 Comparative performance assessment of a non-ventilated and ventilated BIPV rooftop configurations in the Netherlands	111
Chapter 7 Environmental impact comparison of a ventilated and a non-ventilated building-integrated photovoltaic rooftop design in the Netherlands: Electricity output, energy payback time, and land claim	137
Chapter 8 Carrying capacity based environmental impact assessment of Building Integrated Photovoltaics	159
Chapter 9 Conclusions	181
Nomenclature	193
List of publications	197
Curriculum Vitae	199
Acknowledgements	201
Bouwstenen	203

Summary

Summary

Environmental impact assessment of Building Integrated Photovoltaics – numerical and experimental carrying capacity based approach

The continuous increase of extraction, processing and consumption of natural resources creates an increasing environmental impact. The new and existing building stock is responsible for a significant amount of this resource consumption, with collateral environmental impact. To assess the environmental impact of buildings, Life Cycle Assessment (LCA) tools are applied. Currently, there are over 60 LCA tools to assess the environmental impact of buildings. However, these tools have important shortcomings, since they function through weighting of different indicators, are not related to carrying capacity, and are based on a linear process (from 'cradle-to-grave'). In this thesis, the carrying capacity is defined as the ability of a system to (re)generate the resources consumed within the system itself. What is lacking is a fully developed method to assess the environmental impact of a building related to the carrying capacity in a circular non-weighted indicator. The MAXergy approach, developed by researchers at the Wageningen University (WUR) and the Zuyd University of Applied Sciences, consists of a non-weighted single indicator related to carrying capacity, expressed in Embodied Land (EL), covering all process steps involved in construction. EL quantifies the land and time needed to generate and compensate all building related environmental impact, and overcomes the barriers of weighting between environmental impact indicators unrelated to the physical circumstances. With this approach, an environmental impact assessment is reached based on a closed cycle and shows the balance between the building and its carrying capacity.

Currently, within the European Union (EU) it has been agreed that by the end of 2020 all new buildings must be nearly Zero Energy Buildings (*nZEB*'s), and by the end of 2050, the complete building stock has to meet *nZEB* standards to reach the EU sustainability targets. Moving towards *nZEB* and Zero Energy Buildings (*ZEB*) results in a reduction of CO₂ emissions related to the operating phase of the building. However, *nZEB* and *ZEB* development in the North-western Europe climate results in an increase of building material consumption to improve operating energy efficiency by the application of active and passive solutions and technologies in the building envelope such as insulation and PV. Both higher insulation values and PV installations affect the material related environmental impact. PV systems applied in the built environment can either be added to the building envelope (BAPV) or integrated in the building envelope (BIPV). In BIPV both energy aspects (operating and embodied) and material aspects (PV installation, BIPV construction, building construction, and insulation packages) show a strong interaction. However, the environmental impact of BIPV

is not fully understood and LCA application on PV integration in the building envelope has still to be fully developed. The carrying capacity based approach MAXergy expresses environmental impact in the claim on carrying capacity, but the approach does not cover PV integration in the building envelope. To be able to lower the claim on the carrying capacity of our planet, better understanding of all the variables of BIPV influencing carrying capacity based impact is needed, covering not only operating and embodied energy aspects but material aspects as well.

The aim of this thesis was to develop a framework for carrying capacity based environmental assessment of Building Integrated Photovoltaics (BIPV). The framework covers the environmental impact of (operating and embodied) energy and materials of BIPV, and expresses the environmental impact in the claim on carrying capacity. The framework is based on the LCA method and consists of a circular Life Cycle Inventory (LCI) and assessment equations. Two approaches were applied to realize this aim; a numerical approach in the field of environmental assessment model development using the claim on carrying capacity as indicator, and an experimental approach covering BIPV performance measurements and environmental assessment model application in a field test.

The carrying capacity based environmental impact assessments presented in the first chapters of this thesis show that the lowest environmental impact is reached with limited added insulation values and large PV systems, demonstrating the effect of applying a non-weighted joint assessment of materials and energy. The assessments cover different configurations of an office façade renovation and two dwelling building envelope renovations and illustrate that the current trend of increasing insulation values does not result in the lowest overall carrying capacity based environmental impact. In these cases, material related environmental impact becomes the determining factor with respect to the carrying capacity based environmental impact. Building envelope configurations with lower insulation values and large PV systems contribute to reaching ZEB level while showing less carrying capacity based environmental impact than building envelope configurations with high insulation values and small PV systems.

The measurements of the realized BIPV field test presented in this thesis show that the non-ventilated BIPV configuration has a lower electrical performance and shorter lifespan than the ventilated BIPV configurations. Ventilation proves to be an effective way to prevent PV modules from accumulating heat with collateral negative effects on PV performance and lifespan. To investigate the environmental impact of different BIPV configurations, the environmental impact of the realized field test described in this thesis has been assessed in the current situation and three future scenarios covering both Energy PayBack Time (EPBT) and EL. Although the ventilated BIPV shows a higher electrical performance and better end-of-life characteristics, the EPBT is 6-9% longer than the EPBT of the non-ventilated BIPV rooftop configuration, and the claim on carrying capacity of an m² ventilated BIPV rooftop configuration is 10-18% higher than the claim on carrying capacity of the non-ventilated BIPV rooftop configuration.

The future scenarios indicate that due to higher module efficiencies, higher grid efficiencies and lower embodied energy in PV modules, the EPBT can decrease with 28-37% in the optimal scenario, compared to the current situation and the claim on carrying capacity can decrease with 21-40% in the optimal scenario, compared to the current situation. But in all scenarios, the non-ventilated BIPV configuration shows a lower environmental impact than the ventilated BIPV configuration. In this first assessment, the environmental impact assessment is limited to a number of BIPV technologies, configurations and life cycle stages.

The results in the last chapters build further on the results presented in the previous chapters and present a circular Life Cycle Inventory (LCI) and collateral equations to assess the complete life cycle impact of BIPV configurations. The LCI and equations are applied on three different PV technologies; Amorf-Si, Multi-Si and CIGS, in three different BIPV rooftop configurations; non-ventilated, ventilated with an aluminium construction and ventilated with a bamboo construction. Given the selected technologies and BIPV configurations in this study, the Amorf-Si bamboo ventilated BIPV rooftop configuration with current maximum recycling percentages shows the lowest environmental impact but the environmental impact of all configurations exceeds the carrying capacity with current maximum recycling percentages. Reusing and recycling are successful routes for extending cycles with less environmental impact in combination with a minimal portion in the circulation route, emphasizing the necessity of closing loops of non-renewable resources. To stay within the carrying capacity, reusing and recycling percentages of current PV technologies have to be further improved or non-renewable resources have to be eliminated or replaced by renewable resources.

The results of this thesis offer comprehensive insight in current applied environmental assessment tools and carrying capacity based environmental impact related to specific building envelope configurations for offices, existing dwellings and BIPV. This thesis is a step forward in the field of environmental impact assessment by the further development and application of a carrying capacity based environmental impact approach for BIPV rooftop configurations in the Netherlands covering the impact categories energy and materials. This thesis demonstrates the effect of a joint assessment of materials and energy in the building envelope to indicate the overall environmental impact in the single non-weighted indicator EL, related to the carrying capacity. To minimize environmental impact, environmental impact models and LCA application should be based on non-weighted indicators, and the carrying capacity based environmental impact assessment presented and applied to a number of materials and PV technologies in this thesis is an example of a single non-weighted indicator.

This thesis provides guidelines to LCA practitioners and developers to apply carrying capacity based environmental impact in assessment tools. After further development of underlying databases and material cycles, the developed LCI and equations can be embedded in mainstream environmental assessment tools or can be applied independently.

Chapter 1

Introduction

Environmental impact assessment of Building Integrated Photovoltaics – numerical and experimental carrying capacity based approach

Reaching a sustainable society entails many challenges, in many fields. Of those, the (new and existing) building stock is one of the most important and complex fields. It's economic, social, environmental, technological, energetic, and material aspects, as well as the long time periods buildings generally last, demand insight in the environmental impact they have on the carrying capacity of our planet. To evaluate the environmental impact of buildings, a sustainability indicator expressing environmental impact in the claim on carrying capacity is still to be fully developed. This research is focused on the elaboration of a sustainability indicator expressed in the claim on carrying capacity covering two main aspects of a building; energy and materials.

The aim of this thesis is to develop a framework for carrying capacity based environmental assessment of Building Integrated Photovoltaics (BIPV). The framework covers the environmental impact of (operating and embodied) energy and materials of BIPV, and expresses the environmental impact in the claim on carrying capacity.

1.1 Natural resource consumption in a global perspective

The continuous increase of extraction, processing and consumption of natural resources creates an increasing environmental impact. In the period 1980-2013, annual global resource extraction increased with more than 100%, to more than 80 billion tons, shown in Fig. 1 [1], and without significant changes in environmental policies, it is expected to grow to nearly 200 billion tons in 2050 [2]. Natural resources are either abiotic, such as fossil fuels, minerals and metals, or biotic, such as biomass and wood. Some natural resources are used directly, but most resources undergo one or more steps before being used as materials or as a source of energy.

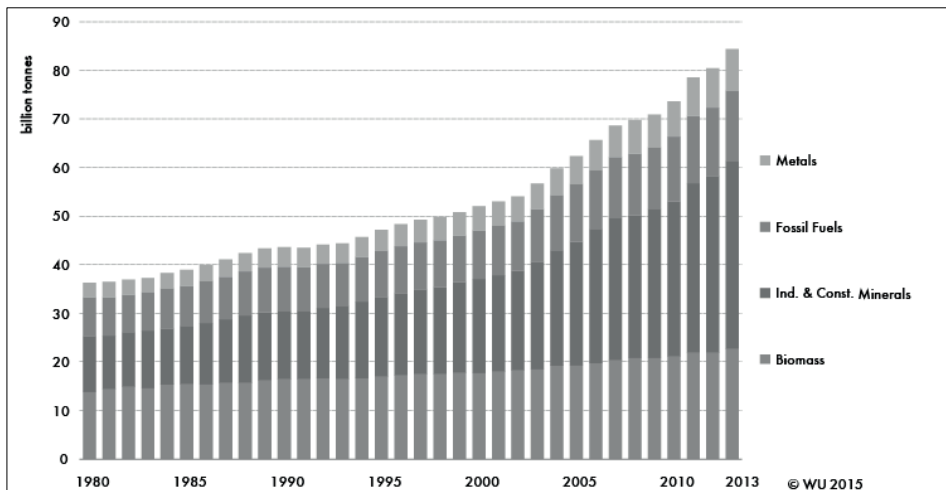

Figure 1. Global resource extraction in the period 1980-2013 [1].

Considering energy, the annual world total Primary Energy Consumption (PEC) in 2012 was more than 155,000 TWh [3]. In the period 1971-2012, annual PEC increased with more than 100%, as shown in Fig. 2, and without significant changes in environmental policies, it is expected to grow to over 300,000 TWh in 2050 [2]. This consumption is mainly based on non-renewable resources such as coal, oil, and natural gas. Approximately 17% of the PEC is used as electricity [4]. Only 1.4% of the PEC is based on renewables, such as geothermal, wind and solar [3]. In 1.5 hours, enough solar energy reaches our planet to fulfill the energy demand of 1 year [5]. One of the technologies applied to convert solar energy into electrical energy is photovoltaics (PV), which has a technical potential of 450,000 TWh·a [6].

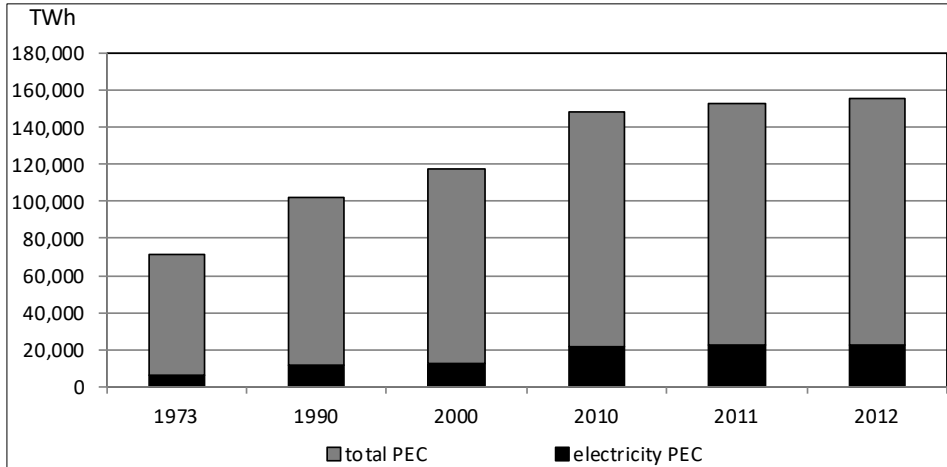

Figure 2. Worldwide Primary Energy Consumption (PEC) and electricity consumption between 1973 and 2012.

The total of PV systems installed by the end of 2013 generate 160 TWh·a electricity, which is expected to increase to over 6,000 TWh·a (16%v of total energy consumption) in 2050 in the high renewable (hi-Ren) scenario of the IEA, as shown in Fig. 3. [7].

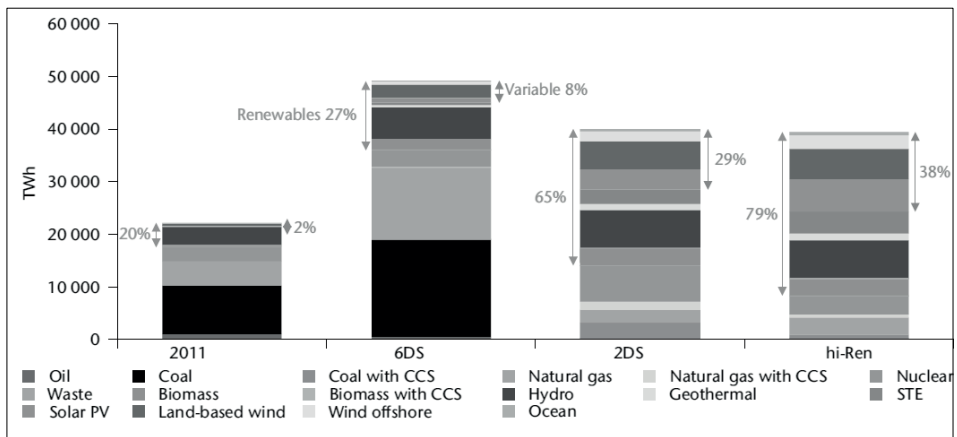

Figure 3. Global electricity mix in 2011 and 2050 in three IEA future electricity scenarios (6 DS: 6°C temperature rise; 2DS: 2°C temperature rise; hi-Ren: high renewables scenario) [7].

Fig. 1, Fig. 2, and Fig. 3 show the increase of global resource extraction, energy supply, and future scenarios of the energy supply, and should be considered in relation to their environmental impact. To indicate environmental impact, Life Cycle Assessments (LCA) tools are applied. One of the indicators that express environmental impact is the 'ecological footprint' [8], which relates the impact of human activi-

ties on the carrying capacity of the planet's ecosystem. In this thesis, the carrying capacity is defined as the ability of a system to (re)generate the resources consumed within the system itself. In 2012, the world population had an environmental impact on carrying capacity of over 1.5 planets to support their activities, as shown in Fig. 4 [9]. With the increasing world population and increasing level of living standards, and without improvement of resource efficiency, 2.5 planets will be necessary in 2050 to maintain our standards of living [10]. This deficit is largely due to CO₂ emissions, as shown in Fig. 4. Global CO₂ emissions originate for 80% from fuel combustion to meet our energy demands [6], making energy efficiency a logical target to lower CO₂ emissions and collateral impact on carrying capacity.

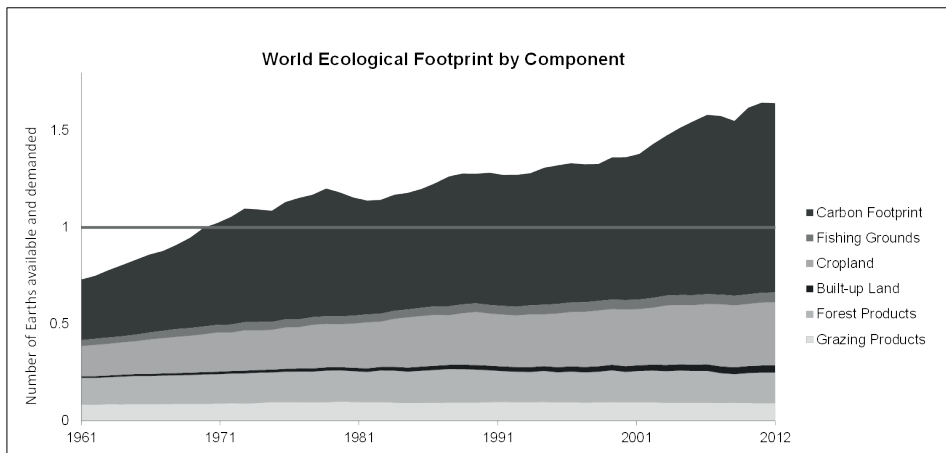

Figure 4. World Ecological Footprint by component [9].

As we currently do not have the natural resources larger than what our planet provides, in the future we will exceed the carrying capacity of planet earth.

The challenge is to balance resource consumption and resource generation in which we do not overexploit the carrying capacity of our planet, while fulfilling our current needs. One of the sectors that consumes a significant amount of resources is the built environment [11].

1.2 Natural resource consumption in the built environment

The built environment is responsible for up to 24% of greenhouse gas emissions, accounts for 40% of the world's total PEC and accounts for 50% of extracted materials [11].

During the first oil crisis in the 1970's, countries in moderate climates such as the Netherlands were confronted with the high level of energy consumption in the built

environment. Consequently, the first legislation was developed to improve the operating energy efficiency. The operating energy of a building is the energy that is consumed by a building to satisfy the demand for heating, cooling, ventilation, lighting, equipment, and appliances [12]. Since the first oil crisis, buildings in the industrialized world have been constructed with higher levels of operating energy performance; they are better insulated, more airtight, and more responsive to the sun, the climate and microclimate [13]. Currently, within the European Union (EU) it has been agreed that by the end of 2020 all new buildings must be nearly Zero Energy Buildings (*nZEB*'s), which implies that (nearly) all building related operating energy is generated on the building site itself by renewable sources [14, 15]. *nZEB* can be reached by a combination of lowering energy demand by insulation and generating energy with renewable sources. By the end of 2050, the complete building stock has to meet *nZEB* standards to reach the EU sustainability targets [16]. While the first legislation was mainly based on mainly economic motives, the subsequent legislation was more based on environmental motives. Moving towards *nZEB* and Zero Energy Buildings (*ZEB*) results in a reduction of CO₂ emissions related to the exploitation phase of the building, increases the energy security and decreases the risk of depletion of fossil fuel reserves [17]. In a *ZEB* all necessary energy is generated on site based on renewable sources, possibly by means of connection to a storage medium or the grid for balancing over days, seasons or the year [18-20]. However, *nZEB* and *ZEB* development in the North-western Europe climate results in an increase of building material consumption to improve operating energy efficiency by the application of active and passive solutions and technologies in the building envelope such as insulation and PV [21].

The challenge is to design, realize and operate a *ZEB* with minimal environmental impact while fulfilling the building demands. Improving the energy performance of the building envelope plays a crucial role in reaching *ZEB* level [22].

1.3 The role of the building envelope

The building envelope is the collection of all building components in which energy, materials, systems, aesthetics, social aspects and legislation coincide into a (preferably high-performance) barrier between the conditioned indoor environment and the outside environment, as illustrated in Fig. 5. Historically, a building envelope was constructed using local materials and based on empirical understanding of local climate and site to protect against influences from outside [23]. With the advance of society and technology, local materials such as reed and mud were replaced by more elaborate building materials such as bricks, wooden beams, glass and steel [24], to meet current building demands covering the indoor climate and energy generation.

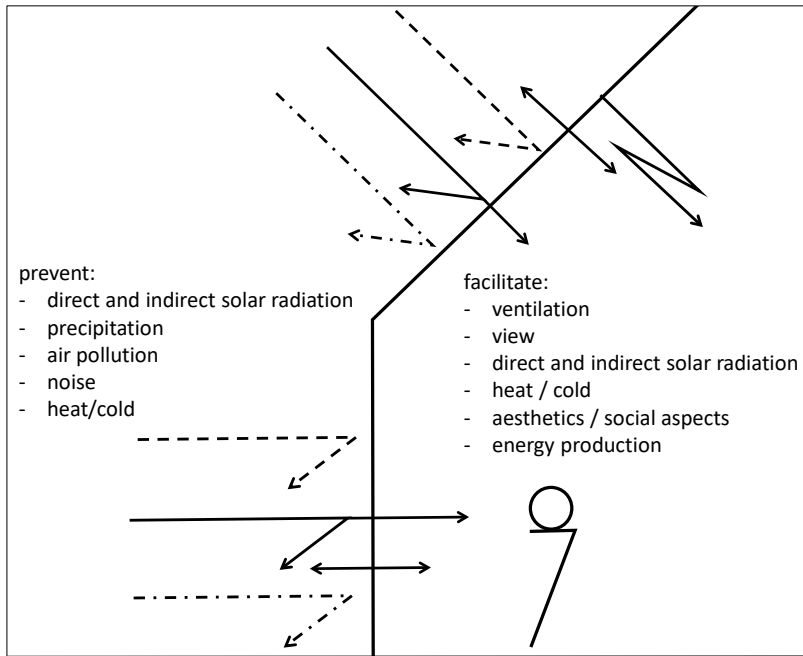

Figure 5. Building demands for the building envelope.

The building envelope influences the energy performance of a building through its thermal characteristics [25]. As the building envelope is the building component that is exposed to the sun it provides the necessary surface for solar energy solutions. The application of solar energy to reach ZEB can be based on either passive or active solutions. Passive solar solutions use the solar energy to help meet the thermal demands of buildings, without the use of electrical or mechanical equipment [26]. Active solar solutions convert solar irradiation in either heat (with solar collectors) or electricity (with PV). Both higher insulation values and energy generating devices affect the material related environmental impact, for example expressed in embodied energy. The embodied energy is the energy necessary to extract, process, and apply building materials. Currently, approximately 26% of embodied energy of a building is necessary for the building envelope [27].

Despite the fact that most parts of the building envelope (roofs and facades) are suitable for the integration of renewable energy generating devices, a great potential of utilizing PV in buildings is still unused. The potential roof and façade surface for building integrated PV is a total of approximately 5,000 km² in the EU [28]. Based on Suri et al [29], 70% of the electricity demand in the EU could be fulfilled by PV in buildings. Degradation over time, PV efficiency improvement, lower efficiencies due to less optimal inclination and/or orientation, grid / storage aspects, and other installation and operational aspects will influence this percentage [30].

The challenge is to develop building envelopes meeting the goals of *ZEB*, while having minimal environmental impact. Building Integrated PV has a large potential to contribute to reaching *ZEB* level, while having less material related environmental impact than conventional PV.

1.4 Integration of photovoltaics in the building envelope (BIPV)

On the track towards *ZEB*, the application of PV systems is a promising and commonly applied solution to generate the necessary electricity. To do this with minimal environmental impact, solutions with maximum energy generation and minimal material consumption should be determined. PV systems play a significant role in this development, but a large portion of the potential for these systems in the built environment remains unused.

PV systems applied in the built environment can either be added to the building envelope (BAPV) or integrated in the building envelope (BIPV). While several definitions of BIPV are used worldwide, in this thesis the term BIPV is used if the installation is technically integrated in the building envelope and contributes to the aesthetic value of the building while being able to generate electricity [31].

BIPV technologies have a market share of about 1-3% of the total PV market [32], and are seen as an important aspect of large-scale PV application [33]. Various approaches and technologies were developed in the past decades, most of which never left the prototype phase. More than 200 different BIPV products have been developed with different techniques worldwide [34]. Only a limited number of these technologies did leave the prototype phase and are applied in the market, but never achieved a substantial market share to be competitive or attractive. The BIPV market shows a Compounded Annual Growth Rate (CAGR) of 39% [35]. In future, the large-scale application of the wide variety of BIPV products and applications will contribute to meeting our energy demand in a sustainable and societal accepted way. The realization and application of BIPV influences not only the energy performance of buildings, but as well the material consumption.

The challenge is to develop BIPV configurations meeting the goals of *ZEB* building envelopes, while having minimal environmental impact. To realize BIPV configurations with minimal environmental impact, the environmental impact of BIPV has to be assessed.

1.5 Environmental impact assessment of BIPV

Considering a *ZEB*, the resource input is limited to the extraction, processing and application of the materials for the building itself, as a *ZEB* generates all necessary

operating energy on-site. Once the operational energy will be completely generated by a ZEB itself, the effect of building materials will become the main indicator in environmental impact, and should be part of the assessment [36-40]. Therefore, the trend to develop a ZEB based only on energy performance will show to be a suboptimal and ineffective route towards a sustainable built environment, unless this approach is expanded with an environmental impact assessment of materials [41].

One of the strategies to assess the environmental impact of materials and energy is in the form of embodied energy (EE) in combination with operating energy (OE). This assessment is expressed in either kWh or MJ over the life cycle of a building, as shown in Fig. 6.

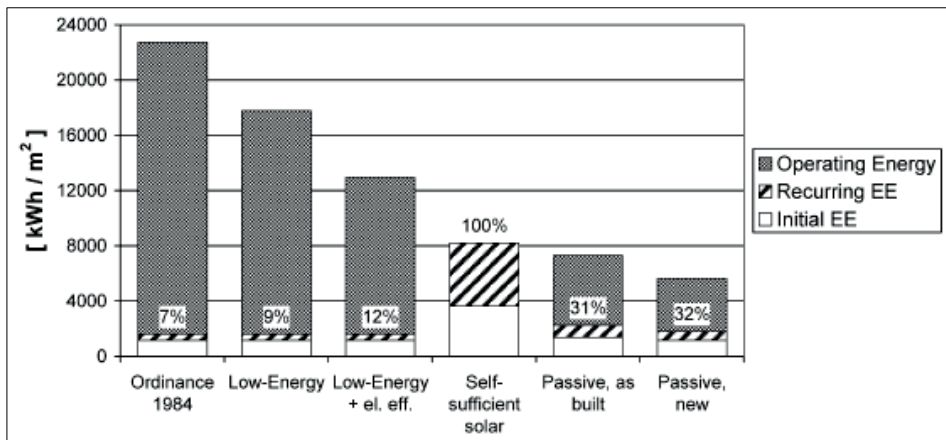

Figure 6. Life cycle primary energy demand in different dwelling types [37].

Currently, there are over 60 building environmental LCA tools in Europe to assess the sustainability of buildings covering not only operating and embodied energy but a wide range of other aspects as well [11], for instance BREEAM, LEED and GreenCalc. Different building environmental assessment tools have been developed in order to investigate the potential of energy-efficiency improvement and material consumption. However, these models often have important shortcomings, since they function through weighting of different indicators, are not related to carrying capacity, and are based on a linear process (from 'cradle-to-grave'). What is lacking is a fully developed method to assess the environmental impact of a building that is optimized from the point of view of energy and materials combined [42]. Ideally, the method has a circular approach taking all phases into account of environmental impact from "extraction-to-extraction". This method takes all aspects into account of environmental impact, such as depletion, scarcity, and availability of the resource. With this approach, an environmental impact assessment is reached based on a closed cycle and shows the balance between the building and its carrying capacity.

In this thesis, a *ZEB* in balance with its carrying capacity is defined as a building that (re-)generates its materials and its embodied energy over its life cycle, complementary to the generation of its operating energy – a *Life Cycle Zero Energy Building (LC-ZEB)* [19]. To evaluate if the environmental impact of a *ZEB* does not exceed carrying capacity, not only the environmental impact of the operating and embodied energy aspects is required, but as well the environmental impact of building materials. In BIPV both energy aspects (operating and embodied) and material aspects (PV installation, BIPV construction, building construction, and insulation packages) show a strong interacting. However, the environmental impact of BIPV is not fully understood.

Until now, LCA applied on PV technologies and the integration in the building envelope have mainly had the purpose to document environmental impact of specific technologies and to identify environmental bottlenecks [43]. LCA application on PV integration in the building envelope has still to be fully developed [43, 44]. Consequently, BIPV configurations are not well embedded in current environmental assessment tools.

A certain amount of land is necessary for a certain timespan to generate operating energy, embodied energy and building materials, resulting in a claim on carrying capacity. The claim on carrying capacity is expressed in Embodied Land (EL), in $\text{m}^2\cdot\text{a}$. EL indicates the land and time needed to generate and compensate all building related environmental impact, and overcomes the barriers of weighting between environmental impact indicators unrelated to the physical circumstances. The MAXergy approach, developed by researchers at the Wageningen University (WUR) and the Zuyd University of Applied Sciences, consists of a non-weighted single indicator related to carrying capacity, expressed in EL, covering all process steps involved in construction. EL for a building consists of three components, (a) EL building, (b) EL materials and (c) EL operational energy [45-47], as shown in Fig. 7.

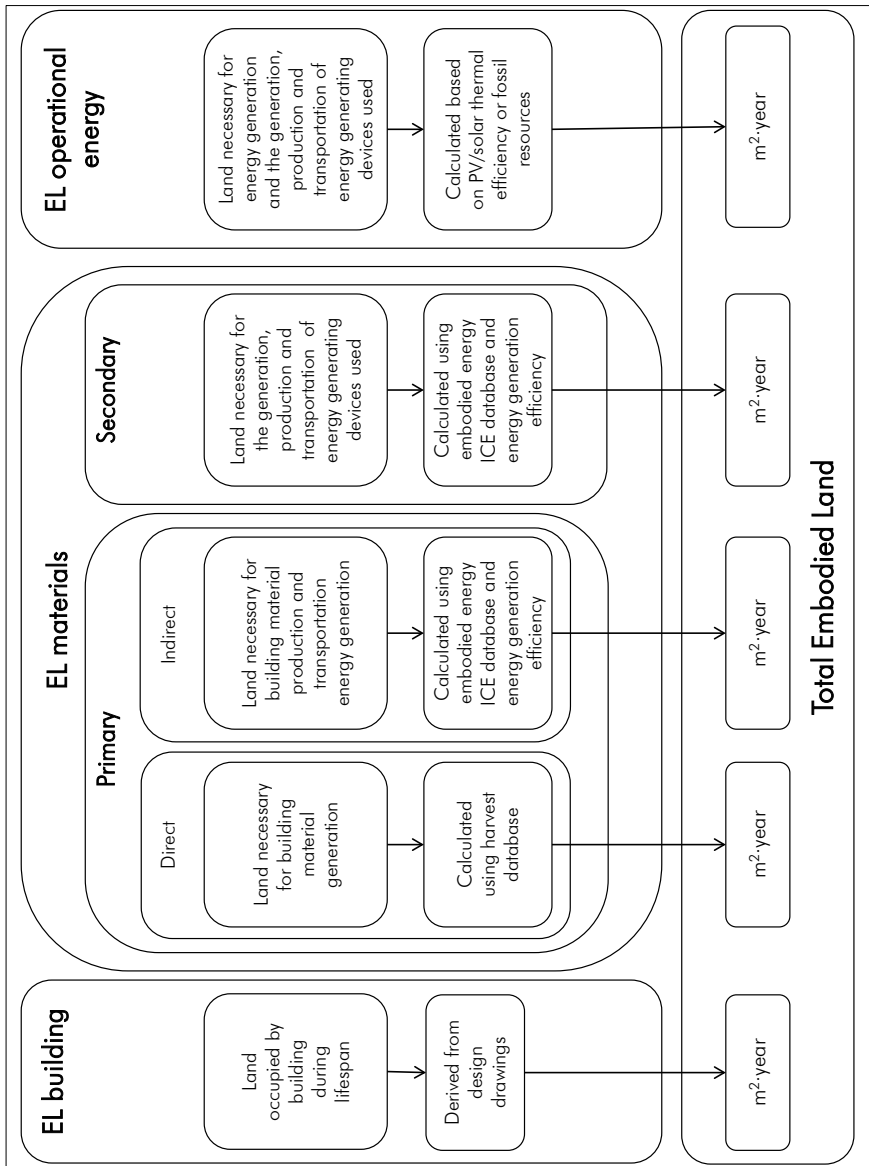

Figure 7. Schematic overview of the proposed Embodied Land calculation method for a combined environmental assessment of energy and materials in the built environment.

The challenge is to be able to assess environmental impact of ZEB BIPV building envelopes related to carrying capacity. The carrying capacity based approach MAXergy expresses environmental impact in the claim on carrying capacity, but the approach does not cover PV integration in the building envelope.

The previous sections show that mankind currently exceeds the carrying capacity of our planet with our environmental impact. ZEB development results in lower envi-

ronmental impact related to the operating energy demand, and the application of BIPV contributes to reaching *ZEB* level. However, in the case of a *ZEB*, material related environmental impact becomes the determining factor with respect to the total carrying capacity based environmental impact. To be able to lower the claim on the carrying capacity of our planet, better understanding of all the variables of BIPV influencing carrying capacity based impact is needed, covering not only operating and embodied energy aspects but material aspects as well. To assess this environmental impact, current applied LCA tools are not suitable because they have the following shortcomings:

1. Current LCA tools have a linear process approach and cover environmental impact from “cradle to grave”, in contrast to a circular approach covering environmental impact from “extraction to extraction”.
2. Current LCA tools do not express environmental impact in claim on carrying capacity of a system, but are limited to land use and land occupation [48].
3. Current LCA tools do not express environmental impact of materials and energy aspects in a single non-weighted indicator.

Due to these characteristics, the application of LCA might create insight in the comparison between different products or processes but it does not generate insight in the claim it has on resource availability and regeneration of these resources within a system – the carrying capacity. The MAXergy approach offers the possibility to assess environmental impact related to carrying capacity in the single non-weighted indicator embodied land. However, the framework for environmental assessment of BIPV configurations is still to be fully developed with this approach.

1.7 Aim and scope of this thesis

The aim of this thesis is to develop a framework for carrying capacity based environmental assessment of Building Integrated Photovoltaics (BIPV). The framework covers the environmental impact of (operating and embodied) energy and materials of BIPV, and expresses the environmental impact in the claim on carrying capacity. The framework is based on the LCA method and consists of a circular Life Cycle Inventory (LCI) and assessment equations.

To realize this aim, experimental research in a BIPV field test is conducted on electrical performance and PV lifespan and numerical modelling of environmental assessment is performed addressing the following research questions:

1. What are building environmental impact assessment tools currently applied in practice, and which indicator is applicable to express environmental impact in the claim on carrying capacity?

2. What is the effect of expressing the environmental impact in the indicator embodied energy and claim on carrying capacity of different building envelope renovation configurations?
3. What is the effect of different BIPV configurations on electrical performance and lifespan of photovoltaics (PV) modules, based on simulation and measurements in a field test?
4. What is the effect of expressing the environmental impact in the indicator energy payback time and claim on carrying capacity of the electrical performance and material consumption of different BIPV configuration?
5. How can the complete life cycle carrying capacity based environmental impact of BIPV configurations be assessed to compare different BIPV configurations?
6. What is the BIPV configuration with lowest carrying capacity based environmental impact, given a selection of technologies and integration possibilities for the realized BIPV field test?

The research conducted in this thesis is limited by the following boundaries:

- Rooftop BIPV.
- Impact categories materials and energy.
- Building envelope configurations for offices and two Dutch dwelling types.
- Data on operating energy and embodied energy based on a selection of simulation software and databases.
- Data access and quality of embodied land based on availability; full datasets have still to be developed.
- Validation of datasets and energy performance simulation was out of the scope of this study.

1.8 Outline of this thesis

This thesis is based on two approaches; a numerical approach in the field of environmental assessment model development using the claim on carrying capacity as indicator, and an experimental approach covering BIPV performance measurements and environmental assessment model application in a field test.

In this first chapter a short introduction about resource consumption is given, from a global perspective to its relevance in the field of BIPV. Additionally, the reason for carrying capacity based environmental impact assessment is introduced, resulting in the problem statement, aim and scope of this research.

In chapter 2 - Making the assessment right, or making the right assessment? - A first notion of the current applied different building environmental assessment tools and their effect on design is presented, addressing the first research question. In this chapter the assessment of two important aspects in relation to a building's environ-

mental impact, energy and materials, is investigated. These aspects are compared in different environmental impact assessment tools and the carrying capacity based environmental impact approach MAXergy is introduced. This chapter emphasizes the difference between the current applied tools and demonstrates the effects of applying a carrying capacity based environmental assessment approach in the built environment.

Chapter 3 and 4 demonstrate the application of the MAXergy approach as a non-weighted environmental impact assessment method presented in chapter 2 and highlight the gaps of this approach, addressing the second research question.

In chapter 3 - Comparison and development of sustainable office facade renovation configurations in the Netherlands - and chapter 4- Environmental impact evaluation of energy saving versus and energy generation in two Dutch dwelling typologies – operating and embodied aspects of different building envelope renovation configurations for different building typologies have been assessed. These studies underline the need for not only energy related environmental assessment, but a combined assessment of materials and energy related environmental impact. These chapters present a first application of carrying capacity based assessment, and emphasize the need for a clearly developed carrying capacity based assessment framework, which will be elaborated focusing on BIPV.

To elaborate on BIPV, chapter 5 – Building Integrated Photovoltaics – presents an introduction on PV application in the built environment and a state of the art of Building Integrated Photovoltaics (BIPV), clarifying the wide scope of BIPV configurations available and the potential of BIPV.

In the experimental approach of this study, one BIPV field test is realized, monitored and dismantled, addressing the third research question.

In chapter 6 - Comparative performance assessment of a non-ventilated and ventilated BIPV rooftop configurations in the Netherlands – the results of the comparative BIPV field test are presented. In this field test, the short and long term effect of backside ventilation on Building Integrated PV (BIPV) performance and lifespan is investigated. The field test includes 24 modules in 4 segments with different levels of backside ventilation. PV energy output, module backside temperature, relative humidity in the air gap, and air velocity in the air gap have been monitored for three years in the period January 2013 – December 2015. At the end of the monitoring period Electric Luminescence (EL) images were made and Standard Testing Condition (STC) power was determined.

The environmental impact of the BIPV field test described in chapter 6 is assessed, addressing the fourth research question.

In chapter 7 - Environmental impact comparison of a ventilated and a non-ventilated building-integrated photovoltaic rooftop design in the Netherlands: Electricity output, energy payback time, and land claim – the environmental impact of building integration of PV is assessed for the realized field test in the Netherlands. Three aspects related to the performance have been calculated; electricity output

difference ($\Delta_{E_{out}}$), Energy PayBack Time (EPBT), and claim on carrying capacity. The EPBT calculations are based on two databases, SimaPro and ICE, and the claim on carrying capacity calculations are made in two models, SimaPro and MAXergy, to demonstrate the effect of different datasets on outcome.

Based on the outcomes of the previous chapters, a framework for BIPV environmental assessment is developed consisting of the LCI and equations and applied on different BIPV configurations, addressing the fifth and sixth research question.

In chapter 8 – Carrying capacity based environmental impact assessment model development for Building Integrated Photovoltaics – The LCA method has been applied to formulate carrying capacity based environmental assessment equations. In this chapter, the equations are applied on three different PV technologies; Multi-Si, Amorf-Si, and copper indium gallium (di) selenide (CIGS), in three different BIPV rooftop configurations; non-ventilated, ventilated with an aluminium construction and ventilated with a bamboo construction. The assessment covers three end of life scenarios; reusing, recycling and circulation.

In chapter 9 – Conclusions, Reflections, and Recommendations – the main conclusions from the different chapters are presented, resulting in overall conclusions, reflections and recommendations for future research and practical application.

References

1. Wien, W.U. *Global material extraction by material category, 1980-2013*. 2017 [cited 2017 3-4-2017]; Available from: <http://www.materialflows.net/trends/analyses-1980-2013/global-material-extraction-by-material-category-1980-2013/>.
2. Schandl, H., et al., *Decoupling global environmental pressure and economic growth: scenarios for energy use, materials use and carbon emissions*. *Journal of Cleaner Production*, 2016. 132: p. 45-56.
3. IEA, *Key World Energy Statistics 2016*.
4. Smets, A., et al., *Solar Energy, the physics and engineering of photovoltaic conversion technologies and systems*. 2016, Cambridge, England: UIT.
5. IEA, *Solar Energy Perspectives*. 2011.
6. Sims, R.E.H., et al., *Energy supply*. In *Climate Change 2007: Mitigation. Contribution of Working Group III to the Fourth Assessment Report of the Intergovernmental Panel on Climate Change* B. Metz, et al., Editors. 2007, IPCC: Cambridge, United Kingdom and New York, NY, USA.
7. IEA, *Technology Roadmap - Solar Photovoltaic Energy*. 2014, International Energy Agency: Paris.
8. Wiedmann, T. and J. Barrett, *A Review of the Ecological Footprint Indicator—Perceptions and Methods*. *Sustainability*, 2010. 2(6): p. 1645-1693.
9. Network, G.F., *National Footprint Accounts, 2016 Edition*. 2016.
10. European Commission, *Environmental indicators – illustrative examples*. 2015 [cited 2016 22-2]; Available from: http://ec.europa.eu/environment/beyond_gdp/environmental_indicators_en.html.
11. CESBA, *CESBA - Initiative Policy Paper - Towards a Common Sustainable Building Assessment in Europe*. 2014.
12. C.S.S.B.I., *Carbon Neutral Steel Building Research Project*. 2013; Available from: <http://cn-sbs.cssbi.ca/operating-energy-buildings>.
13. Straube, J., *Historical Development of the Building Enclosure*. *Building Science Digest*, 2006. 007.
14. European Commission, *Directive 2012/27/EU of the European Parliament and of the Council of 25 October 2012*. 2012.
15. AgentschapNL, *Nationaal Plan voor het bevorderen van bijna-energieneutrale gebouwen in Nederland*. 2012.
16. European Commission, *Directive 2010/31/EU of the European Parliament and of the Council of 19 May 2010 on the energy performance of buildings (recast)*. 2010.
17. Gommans, L., *Gebiedsgerichte energetische systeemoptimalisatie*. 2012, Delft: delftdigitalpress.
18. Hernandez, P. and P. Kenny, *Defining Zero Energy Buildings - A life cycle perspective*, in *PLEA 2008*. 2008.
19. Hernandez, P. and P. Kenny, *From net energy to zero energy buildings: Defining life cycle zero energy buildings (LC-ZEB)*. *Energy and Buildings*, 2010. 42(6): p. 815-821.
20. Peterson, K., P. Torcellini, and R. Grant, *A common definition for Zero Energy Buildings*. 2015, US Department of Energy.
21. Charisi, S., *The Role of the Building Envelope in Achieving nearly Zero Energy Buildings (nZEBs)*. *Procedia Environmental Sciences*, 2017. 38: p. 115-120.
22. Antonini, E., D. Longo, and V. Gianfrate, *Towards nZEB: modular pre-assembled steel systems for residential buildings*. *Transactions on Ecology on The Built Environment*, 2014. 142.
23. Branch, D.P. and J.M. Fitch, *Primitive Architecture and Climate*. 1960.
24. Sandstrom, G.E., *Man, the builder*. 1970, New York: McGraw-Hill.
25. Bano, F. and M.A. Kamal, *Examining the Role of Building Envelope for Energy Efficiency in Office Buildings in India*. *Architecture Research*, 2016. 6(5): p. 107-115.
26. Stevanović, S., *Optimisation of passive solar design strategies: A review*. *Renewable and Sustainable Energy Reviews*, 2013. 25(0): p. 177-196.
27. Cole, R.J. and P.C. Kernan, *Life-cycle energy use in office buildings*. *Building and Environment*, 1996. 31(4): p. 307-317.

28. Defaix, P.R., et al., *Technical potential for photovoltaics on buildings in the EU-27*. Solar Energy, 2012. 86(9): p. 2644-2653.
29. Šúri, M., et al., *Potential of solar electricity generation in the European Union member states and candidate countries*. Solar Energy, 2007. 81(10): p. 1295-1305.
30. Ritzen, M., et al., *Environmental impact comparison of a ventilated and a non-ventilated building-integrated photovoltaic rooftop design in the Netherlands: Electricity output, energy payback time, and land claim*. under review, 2017.
31. Sinapsis, K. and M.v.d. Donker, *BIPV Report 2013, State of the art in Building Integrated Photovoltaics*, SEAC, Editor. 2013, Solar Energy Application Centre: Eindhoven.
32. PV magazine, *BIPV sector*. 2015; Available from: http://www.pv-magazine.com/news/details/beitrag/bipv-sector-to-reach-115-gw-by-2019--says-report_100014922/#ixzz3GyCZ2KyA.
33. Raugei, M. and P. Frankl, *Life cycle impacts and costs of photovoltaic systems: Current state of the art and future outlooks*. Energy, 2009. 34(3): p. 392-399.
34. Jelle, B.P. and C. Breivik, *State-of-the-art Building Integrated Photovoltaics*. Energy Procedia, 2012. 20(0): p. 68-77.
35. Sark, W.v. *Development of innovative educational material for Building-integrated Photovoltaics*. 2017 05-09-2017; Available from: <http://www.dem4bipv.eu/bipv/bipv-market/>.
36. Gommans, L., *The use of material, space and energy from an exergetic perspective*, in SASBE. 2009: Delft.
37. Sartori, I. and A.G. Hestnes, *Energy use in the life cycle of conventional and low-energy buildings: A review article*. Energy and Buildings, 2007. 39(3): p. 249-257.
38. Ritzen, M.J., et al., *Environmental impact evaluation of energy saving and energy generation: Case study for two Dutch dwelling types*. Building and Environment, 2016. 108: p. 73-84.
39. Hernandez, P. and P. Kenny, *Development of a methodology for life cycle building energy ratings*. Energy Policy, 2011. 39(6): p. 3779-3788.
40. Rovers, R., *Zero-Energy and Beyond: A Paradigm Shift in Assessment*. Buildings, 2015. 5(1): p. 1.
41. Rovers, R., et al. *designing for only energy: suboptimisation*. in PLEA 2011. 2011. Louvain-la-Neuve, Belgium.
42. Verbeeck, G., *Optimisation of extremely low energy residential buildings*, in *Faculteit Ingenieurwetenschappen, Departement Burgerlijke Bouwkunde, Afdeling Bouwfysica*. 2007, Katholieke Universiteit Leuven: Leuven.
43. Chatziseridis, M.D., et al., *Ecodesign perspectives of thin-film photovoltaic technologies: A review of life cycle assessment studies*. Solar Energy Materials and Solar Cells.
44. Ritzen, M.J., *IEA PVPS Task 15 workplan*. 2015, IEA.
45. Ritzen, M., et al., *Comparison and development of sustainable office façade renovation solutions in the Netherlands*. Journal of Facade Design and Engineering, 2013. 1(1): p. 53-71.
46. Ritzen, M., et al., *Making the assessment right, or making the right assessment*, in *Architecture and Sustainability*. 2014.
47. Ritzen, M.G., Leo; Rovers, Ronald; Geurts, Chris; Vroon, Zeger; Sigwarth, Stefan. *Insulation versus installation - an exploration towards maximization*. in *SB 13 Implementing sustainability - barriers and chances*. 2013. Munich: Fraunhofer IRB.Verlag.
48. Milà i Canals, L., et al., *Key Elements in a Framework for Land Use Impact Assessment Within LCA (11 pp)*. The International Journal of Life Cycle Assessment, 2007. 12(1): p. 5-15.

Chapter 2

Making the assessment right, or making the right assessment?

Some critical notes on environmental assessment methods used in the Netherlands.

This chapter was published as:

Ritzen, M.J., Rovers, R., Vroon, Z.A.E.P. & Geurts, C.P.W.: *Making the assessment right, or making the right assessment?*

Architecture and Sustainability: Critical Perspectives for Integrated Design, K. Allacker & A. Khan (Eds.), pp. 199-214, Sint-Lucas Architecture Press, Leuven, 2015.

Abstract

While its design has a significant impact on the sustainability of a building, sustainability assessment methods are not widely used in design phases. And if assessment methods are applied, it is debateable whether they can generate the insights that are needed to realize a truly sustainable built environment. In this chapter the assessment of two important aspects in relation to building sustainability, energy and materials, is investigated. These aspects are compared with regard to different assessment strategies. Finally, an alternative indicator offering another perspective on assessing sustainability in relation to architecture is introduced.

Introduction

The elementary design of a building, often determined by an architect in the conceptual design phase, has a significant impact on the energy consumption of the building [1, 2]. Besides the energy challenges we meet nowadays worldwide, construction material extraction increased worldwide between 1995 and 2005 by 30% [3]. Energy, embodied in buildings, accounts for up to 60% of the building's life cycle energy [4].

As energy and materials play an essential role in our well-being and society, the increasing consumption of these resources, along with the collateral depletion of non-renewable sources and greenhouse gas (GHG) emissions, forms a threat to the robustness of our current system.

With regard to lower energy consumption, energy dependency and GHG emissions, European and Dutch policies have various aims, including improving the energy efficiency of the built environment, in order to fulfil the target that all new buildings from 2020 onward have to be nearly zero energy buildings (*nZEB*) [5, 6]. Although no standard definition for *nZEB* exists, it can be explained as a Dutch Energy Performance Efficiency of 0, implying that all building related operating energy is generated on the building site itself by using renewable sources, calculated on a yearly basis [6, 7].

Numerous assessment tools are available to indicate the energy efficiency performance and can be used to indicate the level at which the building meets policy criteria and aims. These tools have a number of other advantages, such as distinction in the level of sustainability of a building, providing a communication tool, encouraging stakeholders to define certain requirements, and providing a vehicle for policy [8].

The material aspect plays a negligible role in most building related sustainability assessment tools in comparison with the energy aspect. Due to the increasing amount of materials consumed in the built environment, and its potential environmental impact, material consumption will however play an increasing role, and will possibly determine the environmental impact of buildings in future. In most tools different aspects such as energy, water and materials are combined through a weighted system, leading to a single outcome indicator.

In this chapter it is discussed whether current tools create the necessary insight in material and energy impact to realize the level of sustainability aimed at. A measurable definition of sustainability is proposed in order to indicate the building environmental impact more clearly in relation to the situation. Different assessment strategies are furthermore investigated and an assessment indicator is introduced for material and energy impact in order to provide the relevant insights in the environmental impact of a building.

Sustainable or not, that is a question

There is a tendency nowadays to call many developments and products 'sustainable', implicating a variety of interpretations of this definition. The concept of sustainability is based on the ethical concern that the environmental, societal and economic system as we have it now should be available to future generations [9]. Hartig described the following in 1804: "...Every wise forest director has to have evaluated the forest stands... ... to utilize them to the greatest possible extent, but... ... in a way that future generations will have at least as much benefit as the living generation..." [10]. But earlier on there were signs of notions of sustainability, mostly forestry related. Not surprisingly, as forests were an essential source of resources for society and people became increasingly aware of their dependency on forest based resources.

More than 200 years later, the idea of sustainability is general accepted. The definition of sustainability most widely used is mentioned in the Brundtland report 'Our Common Future' (1987). "*Sustainable development is development that meets the needs of the present without compromising the ability of future generations to meet their own needs*" [11]. This report and its definition of sustainable development have contributed greatly to sustainability awareness worldwide. However, as this definition leaves space for interpretation and is not related directly to our resource consumption, in this chapter we will use a definition of sustainability based on the view of Gladek et al.: "*Sustainability is a state of a complex, dynamic system. In this state a system can continue to flourish without leading to its internal collapse or requiring inputs from outside its defined system boundaries*" [12]. This view corresponds to other views on sustainability in which it is proclaimed that we can only speak of a sustainable product or service if its creation places no burden whatsoever on future generations. In continuation of this view, we will refer to being sustainable as being in equilibrium with a system in relation to a building.

This chapter focuses on the energy and material aspects of building sustainability as these play an essential role in our wellbeing and society and offer the possibility of being combined in a single indicator. Social, economic and other aspects are left out of the scope. Further research should be conducted on the complexity and interrelationship between different aspects and possible burden shifting between them [13].

Mono –and multi-aspect approaches

Both mono-aspect and multi-aspect sustainability assessment approaches can be distinguished. In mono-aspect approaches, one aspect is investigated, resulting in one indicator. Examples are the operational energy consumption of a building (in kWh or MJ); or the water consumption (in m³ or litres); or the GHG emissions (in tonnes CO₂ equivalent (t CO₂-e)). Mono-aspect approaches are able to generate insight into one aspect in depth, but do not offer an indication of the total environ-

mental impact of a building. An example of a mono-aspect approach in the Dutch situation is the optimisation of the energy efficiency through the mandatory application of the energy performance calculation and its criterion, which might result in a sub-optimal total environmental impact [14]. The same accounts for the European situation when focusing on the development of *nZEBs* [15].

In multi-aspect approaches, different aspects are combined. This might include two aspects which share a common unit or many aspects with different units and indicators. One multi-aspect method which is widely used to combine material consumption and energy using a common unit is the calculation of material related energy consumption, embodied energy, which can be compared with operational related energy consumption, operational energy [16, 17]. In an operational and embodied energy calculation, the energy and material aspect is calculated by using one common unit (MJ or kWh). A standard calculation method and system boundary definition is however lacking, resulting in a large variety of results [4]. Another quantity, such as CO₂, might be a sub-optimal indicator for the environmental impact of a building, because *nZEBs* have only little operational CO₂ emission and it may be doubted whether there is enough land for off-setting all emissions or compensating for all the resulting environmental impact [18]. Thus the combination of energy and materials in a single energy or carbon related indicator alone might not create insight into the actual environmental impact of a building.

There are numerous examples of multi-aspect approaches such as different footprint approaches and different types of Life Cycle Assessment (LCA) [8, 19]. Although there is no clear definition of a 'footprint' and calculation standard, it is used to indicate the environmental impact in land area necessary for a building [8]. In an LCA the environmental impact of a process or product is calculated based on the inventoried input and output flows (e.g. materials, energy, water) [20]. The Ecological Footprint is seen by the European Union as a useful indicator for assessing resource efficiency improvement, but the tool is subject to assumptions, limited data and uncertainty of data [8, 13]. Both LCA and Footprint tools are based on different techniques such as input-output, hybrid analyses and process based analyses [21, 22]. One of the weaknesses of these tools is the amount of data involved and its lack of availability [8]. Currently, many building orientated tools are being used and further developed [23]. In figure 1 an overview is given of a number of these tools and the different aspects they address. Besides the advantages of these tools mentioned in the introduction, the level of sustainability for comparable buildings differs due to the different aspects addressed and weighting scheme used [23]. According to Iwaro et al., the measurements and the weights that should be given to the criteria are unresolved issues [24]. In the end, these tools might show how the energy and/or material situation has improved, but do not show how the actual environmental impact has improved, because the scores are diluted by many aspects and weightings.

	Energy & atmosphere	Water Efficiency	Materials & Resources	Renewable Energy	Pollution & Emission	Indoor Environmental Quality	Health & Wellbeing	Economic Quality	Land use & Ecology	Sustainable Sites	Waste & Recycling	Transport Location & Linkages	Maintenance/Operation ⁿ	Socio-Cultural Aspects	User Awareness Education	Innovation/Design process
BREEAM	+	+	+	+	+	-	+	-	+	-	+	+	-	-	+	-
LEED	+	+	+	+	+	+	0	-	-	+	+	0	-	-	+	+
DGNB	+	+	+	+	+	-	+	+	-	0	+	+	+	+	-	-
CASBEE	+	+	+	+	+	+	-	-	+	0	-	-	0	-	-	-
ITACA	+	-	+	+	+	+	0	-	0	+	0	-	0	-	-	0
HQE	0	+	0	-	+	+	+	-	0	0	+	-	+	-	-	-
LIDERA	+	0	0	-	+	+	-	0	+	+	0	-	-	+	0	0

+ Fully considered
 0 Partly considered
 - Not considered

Figure 1. Overview of aspects addressed in different assessment tools.

Generic sustainability assessment tools combine numerous aspects such as innovation, design, management, social, economic and environmental issues. The Building Research Establishment Assessment Method (BREEAM) and the Leadership in Energy and Environmental Design (LEED) are two such tools. For the Dutch situation, an adapted version of BREEAM, BREEAM-NL will be referred to in this chapter. LEED has no adapted versions for different locations and climates. Both BREEAM-NL and LEED indicate the level of sustainability in one term (e.g. excellent) based on the assessment of multiple aspects through a weighted system (graph 1 and 2). Both tools are extensively applied worldwide [25-27]. Different categories are applied in both assessment methods and energy and materials account for different percentages of the total building performance. The different categories are divided into subcategories and the grading of the subcategories depends on different quantitative and qualitative parameters. The parameters are based on performance and evaluation, while different system boundaries are used and different levels of detail are applied. In consequence the outcomes of these different assessment methods are difficult to compare and create a dilemma with regard to what the connection is between the outcome of the assessment tool and the actual environmental impact of the building.

Making the assessment right, or making the right assessment?

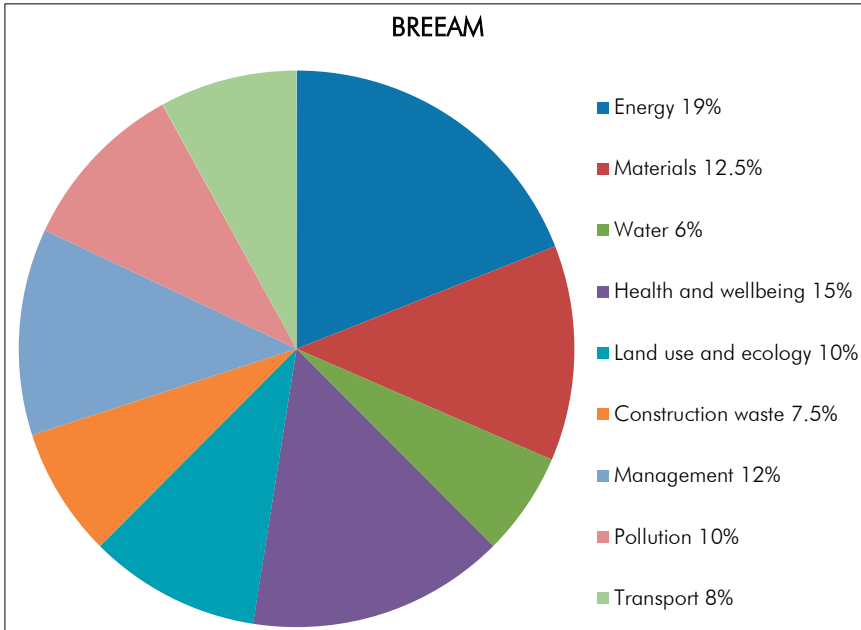

Graph 1. Different aspects and their relative weighting in BREEAM-NL [25].

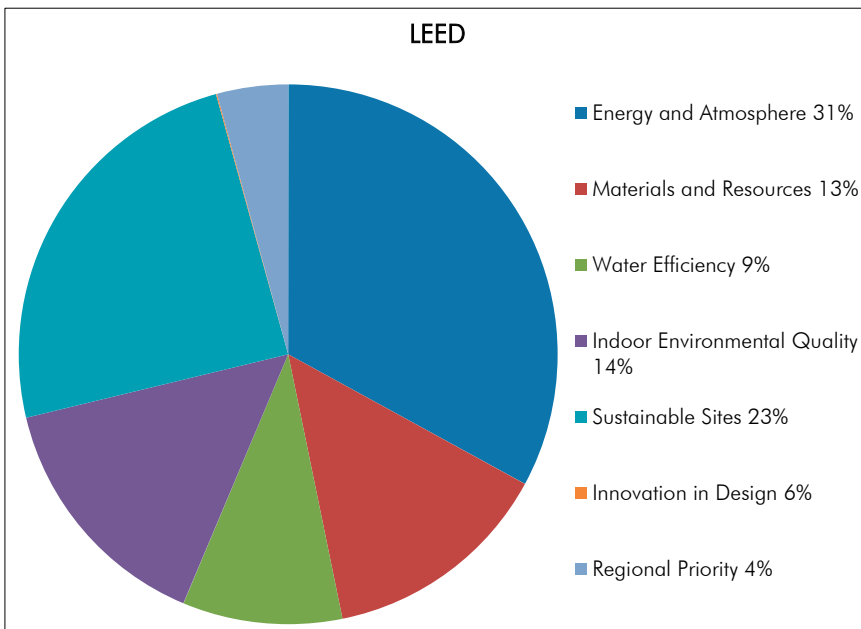

Graph 2. Different aspects and their relative weighting of LEED [26].

Thus, while sustainability has become a widespread term used in the building industry and architectural design, it can be discussed if existing sustainability assessment tools generate the essential insight regarding the consequences of design choices on total environmental impact and lead to a more sustainable built environment [20].

Going back to forestry, sustainability needs to be based on what can be produced in balance with the carrying capacity, implying a measurement based on the possibilities of a system. This is in contrast with assessments based on theoretical impact (such as embodied energy and GHG emissions) or outcomes of multi-aspect tools, which have no connection with the actual impact on the system at all.

Carrying capacity

In this section, an indicator is proposed as a design strategy to assess sustainability based on the carrying capacity of a system, as this defines the possibilities for energy and material consumption. The strategy generates insight into a comparable assessment of energy and material use by calculating a footprint in time-land necessary to generate the necessary energy and materials, as, in the end, land is one of the most valuable resources on Earth and together with time is the most important boundary of our system [20].

The strategy is based on a further elaboration on the footprint calculation of the concept of Energy, which is defined as the amount of solar energy, both indirect and direct, used to create a product in combination with the Sustainable Process Index (SPI) and the concept of ecological footprint. SPI is based on the surface area required for the conversion of solar energy into a product or service. The ecological footprint concept is based on the surface area needed to produce the resources a population consumes and to absorb part of fossil energy related waste [28-30]. Whereas Energy only calculates the amount of solar energy, whereas SPI only calculates the necessary land, and whereas the ecological footprint only calculates land in relation to fossil energy, the proposed calculation is based on the combination of solar energy, land and time.

The strategy consists of two principles: (a) the sun is the main source adding energy to our system; and (b) time and land are needed to convert solar energy into a product or service. In this sense, both materials and energy can be calculated to the same physical quantity, $\text{m}^2 \cdot \text{year}$. To calculate the land-time impact, a calculation method called MAXergy is under development, and expresses itself in Embodied Land (EL) [31]. The EL of a product (in $\text{m}^2 \cdot \text{year}$) indicates the amount of land needed for the extraction of raw materials, the growth of materials, the generation of power, the recuperation of land, etc. for the Dutch situation [31-33].

EL for a building consists of three components, (a) EL building, (b) EL materials and (c) EL operational energy, as indicated in figure 2.

- a. EL building indicates the land occupied by the building during its lifespan and can be directly derived from the design drawings.
- b. EL materials consists of two impacts:
 1. The primary impact indicates the time-land required to generate, produce and transport the material. The primary impact consists of the direct EL for material generation, such as the forest area needed for timber and area related to ores, and indirect EL for material extraction, production and transportation. The direct primary EL is calculated using a harvest database in which harvest/m² are collected, depending on the origin of the material. The indirect primary EL is based on the ICE embodied energy database and through energy generation surface calculated (solar or fossil based) [34].
 2. The secondary impact indicates the time-land required to generate and produce the techniques and installations necessary to generate the materials; e.g. the photovoltaic panels required to generate the necessary embodied energy. The tertiary impact and other possible relevant impacts, such as operational transportation energy, are not taken into account [35].
- c. EL operational energy consists of the time-land necessary to generate the energy using solar energy (PV/ solar thermal) or fossil resources and the EL necessary for the generation, production and transportation of the materials used for the energy generating devices.

The EL calculations are based on existing land harvest facts, existing embodied energy databases, and energy generating efficiencies, wherever possible for the Dutch situation, which at this moment is a limitation of the model, as harvests, amounts of embodied energy, and energy generation efficiency differ across the world. The method can be used as a tool to generate architecture from a sustainable perspective, and contributes to a rethinking of material and energy aspects in architecture, as will be illustrated in the following example.

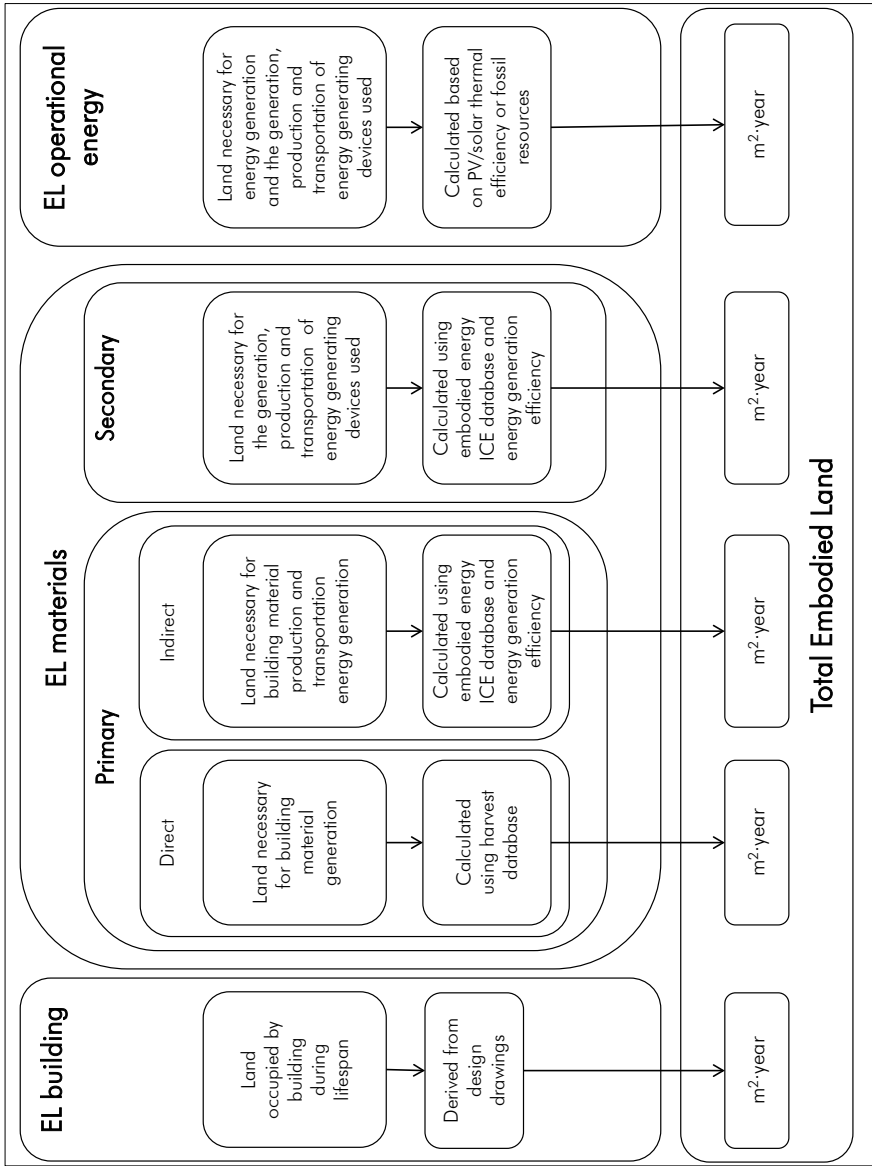
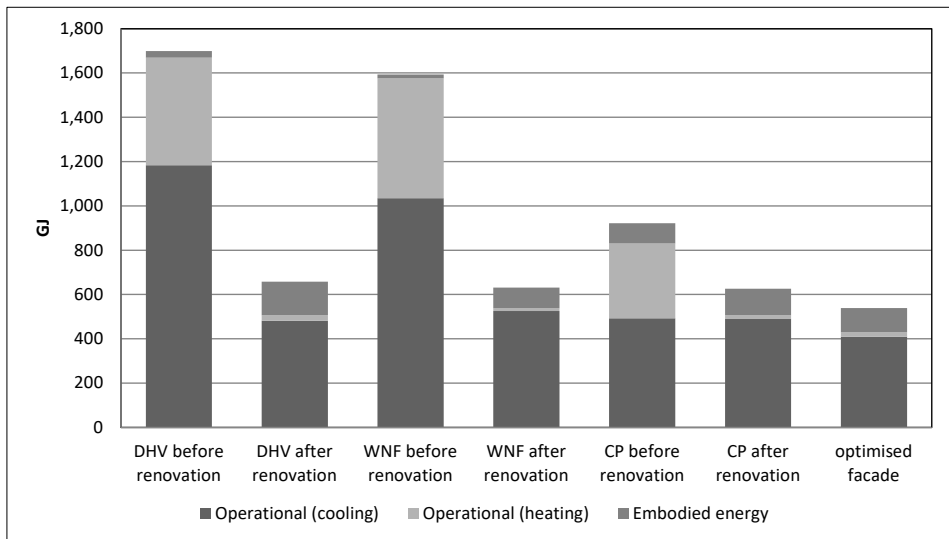

Figure 2. Schematic overview of the proposed Embodied Land calculation method for a combined environmental assessment of energy and materials in the built environment.

Sustainable office renovation

In this project the environmental impact of a south-facing façade of three sustainable office renovation projects in the Netherlands was investigated. In all projects the renovation had a positive effect on the operational energy performance, and a relatively small impact on the embodied energy performance of the facade (graph 3). The percentage of embodied energy is low due to the high operational energy load (cooling), the lifespan of 30 years and might fluctuate depending on the process data used. However, depending on the design choices the renovation has a significant impact on EL (graph 4) due to material consumption. Both in the renovation of the office of Dwars, Heederik and Verhey (DHV) building and the Central Post (CP) building many fossil resource based materials were used, whereas the Dutch World Wildlife Fund (WNF) building has been renovated with mostly renewable materials.



Graph 3. Life cycle energy performance of various retrofitting scenarios for the investigated office buildings in the Netherlands over 30 years, by use.

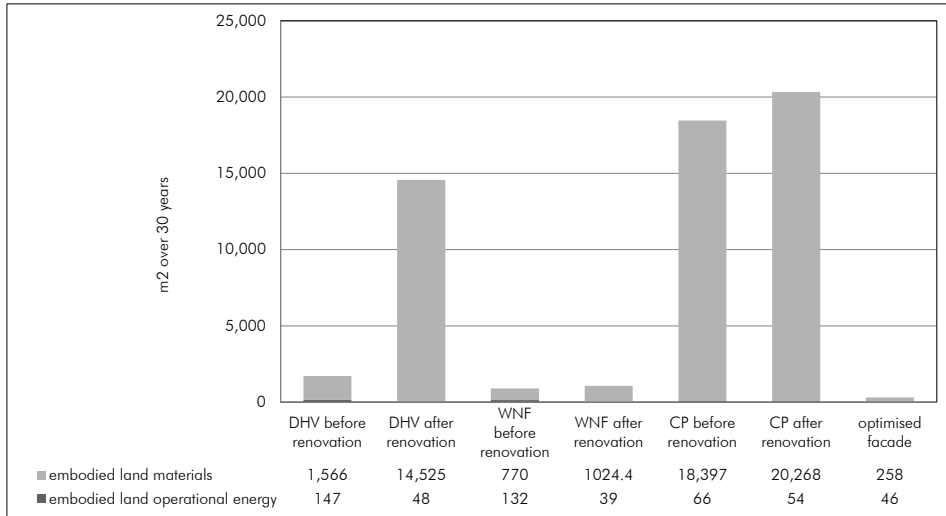

Graph 4. Embodied Land performance of various retrofitting scenarios for office buildings in the Netherlands over 30 years, based on solar energy for operational energy.

The best performing office renovation based on energy and EL (WNF) has been further improved using MAXergy. The improvement consists of firstly lowering the total amount of materials and secondly of replacing non-renewable materials by renewable materials within the boundaries of the Dutch legislation. This has resulted in an adapted version, in which cladding materials are all renewable, the glass surfaces are minimized and the structural elements such as steel pins and screws are replaced by bio-based versions. In figure 3 and 4 the renovated façade and the EL improved façade are shown, of which the architectural value in comparison with the renovated situation can be discussed.



Figure 3. Picture of the realised façade retrofitting of the WNF. (vd Meijden)

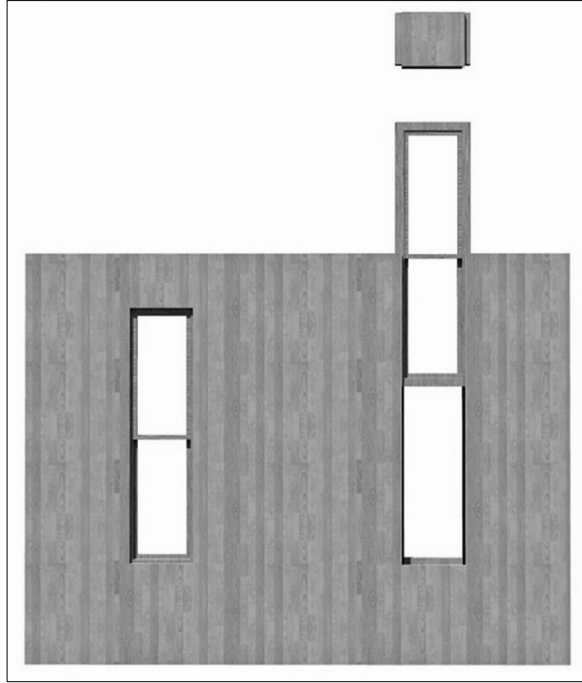

Figure 4. Picture of the Embodied Land optimised retrofitting of the WNF facade, resulting in a façade with minimal fossil material consumption. Even window placing has been designed without metal components. (vd Meijden)

Discussion

For most footprint methods, various definitions and calculation methodologies are used which result in different outcomes [4]. Most footprints have moreover uncertainties due to temporal, spatial and technical circumstances (location, weather, societal energy generation), which in many cases are not shown in the databases underlying the calculation tools. A third point regarding footprint methods is the flexible system boundary definition. All these aspects have resulted in large amounts of data with large bandwidths, which are used in a considerable number of calculation methods without standardization, leading to a large bandwidth of results [4]. It is therefore very difficult to assess different aspects towards one indicator, and although EL is an indicator directly related to environmental impact, as long as the underlying calculation methods show large bandwidths the results can be disputable.

Although Best et al. mention that one single indicator is unable to provide insight in the complexity and interrelations of impacts, the EL single indicator does offer such insight, but is still not complete due to the lack of water consumption, emissions, etc.

[13]. In further research, the combination and interrelation between all aspects should be investigated in order to aim at a single outcome tool based on EL.

It can be doubted if combining social, economic and other aspects with aspects related to materials and energy would lead to a lowering of the environmental impact due to the difference in indicators. Further research should be conducted on translating social and economic aspects in EL.

Conclusions

Due to the increasing interest in the sustainability of society as a whole and especially in the building industry, an increasing number of tools can be applied. It is uncertain if these tools actually contribute to lowering the total environmental impact of a building, due to their lacking relationship with the system and its carrying capacity. The EL indicator contributes to improving material and energy-related insight in the actual environmental impact of a building by relating it to its carrying capacity. By using the EL indicator, the environmental impact of a building is related to less abstract terms than 'GHGs' and 'MJ' and more to a closed cycle resource evaluation. In future, by adding various aspects such as water consumption and emissions to the EL indicator, the tool might offer a more complete view on the total environmental impact of a building.

Material consumption becomes the determining factor with respect to the building environmental impact when all operational energy is generated by renewable energy sources on site. EL calculations indicate that the amount and the choice of materials determine the environmental impact. It is an architectural challenge to realize zero energy buildings with minimal environmental impact in Embodied Land, emphasizing the need to rethink architecture from a holistic viewpoint, taking both energy and materials into account.

References

1. Kanters, J., M. Horvat, and M.-C. Dubois, *Tools and methods used by architects for solar design*. Energy and Buildings, 2010(0).
2. Sesana, M.M. and G. Salvalai, *Overview on life cycle methodologies and economic feasibility for nZEBs*. Building and Environment, 2013. 67: p. 211-216.
3. Bruckner, M., et al., *Materials embodied in international trade – Global material extraction and consumption between 1995 and 2005*. Global Environmental Change, 2012. 22(3): p. 568–576.
4. Dixit, M.K., et al., *Need for an embodied energy measurement protocol for buildings: A review paper*. Renewable and Sustainable Energy Reviews, 2012. 16(6): p. 3730-3743.
5. Hernandez, P. and P. Kenny, *Development of a methodology for life cycle building energy ratings*. Energy Policy, 2011. 39(6): p. 3779-3788.
6. Torcellini, P., et al., *Zero Energy Buildings: A Critical Look at the Definition*, in ACEEE Summer Study. 2006, NREL: California.
7. AgentschapNL, *Nationaal Plan voor het bevorderen van bijna-energie neutrale gebouwen in Nederland*. 2012.
8. Čuček, L., J.J. Klemeš, and Z. Kravanja, *A Review of Footprint analysis tools for monitoring impacts on sustainability*. Journal of Cleaner Production, 2012. 34(0): p. 9-20.
9. Wiersum, K.F., *200 years of sustainability in forestry: Lessons from history*. Environmental Management, 1995. 19(3): p. 321-329.
10. Schmutzenhofer, H. *The IUFRO position on sustainable management of tropical forests*. 1994 [cited 2013 8-7-2013]; Available from: <http://www.fao.org/docrep/w3646e/w3646e06.htm>.
11. Brundtland, *Report of the World Commission on Environment and Development - Our Common Future*. 1987.
12. Gladek, B. *Symbiosis in Development (SiD) - Systemic sustainability methodology*. 2011; Available from: <http://www.except.nl/en/#.en.articles.148-symbiosis-in-development-sid>.
13. Best, A., et al., *Potential of the Ecological Footprint for monitoring environmental impacts from natural resource use: Analysis of the potential of the Ecological Footprint and related assessment tools for use in the EU's Thematic Strategy on the Sustainable Use of Natural Resources*. 2008.
14. Ritzén, Michiel; Gommans, Leo; Rovers, Ronald; Geurts, Chris; Vroon, Zeger; Sigwarth, Stefan. *Insulation versus installation - an exploration towards maximization*. in SB 13 Implementing sustainability - barriers and chances. 2013. Munich: Fraunhofer IRB.Verlag.
15. Stephan, A., R.H. Crawford, and K. de Myttenaere, *A comprehensive assessment of the life cycle energy demand of passive houses*. Applied Energy, 2013. 112(0): p. 23-34.
16. Sartori, I. and A.G. Hestnes, *Energy use in the life cycle of conventional and low-energy buildings: A review article*. Energy and Buildings, 2007. 39(3): p. 249-257.
17. Ramesh, T., R. Prakash, and K.K. Shukla, *Life cycle energy analysis of buildings: An overview*. Energy and Buildings, 2010. 42(10): p. 1592-1600.
18. Rovers, R., et al. *designing for only energy: suboptimisation*. in PLEA 2011. 2011. Louvain-la-Neuve, Belgium.
19. Cabeza, L.F., et al., *Affordable construction towards sustainable buildings: review on embodied energy in building materials*. Current Opinion in Environmental Sustainability, (0).
20. Crawford, R.H., *Life cycle assessment in the built environment*. 2011, New York, USA: Spon Press.
21. Suh, S., *Functions, commodities and environmental impacts in an ecological-economic model*. Ecological Economics, 2004. 48(4): p. 451-467.
22. Treloar, G., *A comprehensive embodied energy analysis framework*, in Faculty of Sciences and Technology. 1998, Deakin University.
23. Häkkinen, T.e., *Sustainability and performance assessment and benchmarking of buildings - Final report*. 2012, VTT: Espoo.

Chapter 2

24. Iwano, J., et al., *An Integrated Criteria Weighting Framework for the sustainable performance assessment and design of building envelope*. Renewable and Sustainable Energy Reviews, 2014. 29(0): p. 417-434.
25. D.G.B.C., *BREEAM-NL Nieuwbouw*. 2012; Available from: http://www.breeam.nl/nieuwbouw/procedure_nieuwbouw.
26. U.S.G.B.C., *LEED 2009 for new construction and major renovations*. 2013.
27. Alyami, S.H. and Y. Rezgui, *Sustainable building assessment tool development approach*. Sustainable Cities and Society, 2012. 5(0): p. 52-62.
28. Brown, M.T. and S. Ulgiati, *Energy quality, emergy, and transformity: H.T. Odum's contributions to quantifying and understanding systems*. Ecological Modelling, 2004. 178(1-2): p. 201-213.
29. Narodoslawsky, M. and C. Krotscheck, *The sustainable process index (SPI): evaluating processes according to environmental compatibility*. Journal of Hazardous Materials, 1995. 41(2-3): p. 383-397.
30. Huijbregts, M.A.J., et al., *Ecological footprint accounting in the life cycle assessment of products*. Ecological Economics, 2008. 64(4): p. 798-807.
31. Rovers, R., *MAXergy and embodied land*, RiBuiT, Editor. 2011.
32. Rovers, R. *0-material building: space time analyses*. in *SB10*. 2010. Maastricht, the Netherlands.
33. Rovers, V., et al., *Maxergy, duurzaamheidsberekening op basis van landgebruik*. 2011, RiBuiT / Zuyd University of Applied Sciences.
34. Hammond, G.J., C., *Inventory of Carbon and Energy (ICE)*. University of Bath, UK, 2008.
35. Stephan, A., R.H. Crawford, and K. de Myttenaere, *Towards a comprehensive life cycle energy analysis framework for residential buildings*. Energy and Buildings, 2012. 55(0): p. 592-600.

Chapter 3

Comparison and development of sustainable office façade renovation solutions in the Netherlands

This chapter was published as:
Ritzen, M.J., van den Meijden, B., Rovers, R., Vroon, Z.A.E.P. & Geurts, C.P.W.:
*Comparison and development of sustainable office façade renovation solutions in the
Netherlands.*
Journal of Facade Design and Engineering, vol. 1, no. 1-2, pp. 53-71, 2013

Abstract

Environmental, commercial and societal developments in the Netherlands stimulate the environmental improvement of the existing office building stock. In the Netherlands, about 15% of all office area was vacant in 2012, and the majority of offices have a relative poor energy performance. To measure the improvement, different assessment tools are applied. These tools either focus on one aspect, such as operational energy, and result in a specific outcome such as MJ/m², or these tools combine different aspects, such as energy and materials, through a weighted system and result in a generic outcome, such as 'excellent'. In this research, the relation between assessment outcome and actual environmental impact is investigated of both types of tools, by reflecting the outcome of the tool to the carrying capacity of a system. The relation is investigated through a comparison of the energy and material aspect of three office façade renovation solutions using four different assessment tools. Using a tool in which energy and material impact is related to the carrying capacity, current energy focused optimisation might lead to a sub optimisation of actual environmental impact. To illustrate this, a calculated façade solution is presented with minimal environmental impact based on carrying capacity.

1. Introduction

Between 1990 and 2005 global final energy consumption increased by 23% and CO₂ emissions increased with 25% [1]. This consumption is expected to grow with another 45% between 2002 and 2025 [2]. 20% to 40% of this global energy consumption is consumed in the built environment [3], for more than 86% based on fossil fuels [4]. Between 1995 and 2005, extraction of fossil fuels increased with 24% [5]. To lower overall energy consumption in the built environment and to lower dependency on fossil fuels, it is agreed within the EU that by the end of 2020 all new buildings are *nearly zero-energy buildings (nZEB)*, and that by the end of 2018 all new buildings occupied and owned by public authorities are *nZEBs* [6]. *nZEB* means that the building has a very high energy performance and that the low amount of energy required should be generated to a very significant extent from renewable sources, on-site or nearby, having a connection to the grid to cope with seasonal differences [6-8]. Reaching the target of *nZEB* depends only on improving the energy efficiency in the operational phase of the building. This requires adding material to the building for thermal insulation, building services and energy generation products. Consequently, the realization of a less energy consuming built environment is largely depending on an increase of material consumption, and collateral increase of construction material extraction, resulting in an increase of the material related impact compared to the energy related impact [9]. Worldwide, extraction of construction minerals increased between 1995 and 2005 with 30% [5].

Besides improving the energy performance of new buildings, improvement of the energy performance of existing buildings is increasingly being realized, amongst others in the office sector.

The Dutch office market, consisting of 52.2 million square meters, had a vacancy percentage of 14.6% in 2012 [10], corresponding with 7.62 million square meters. As the market situation of office buildings in the Netherlands is not in equilibrium, renters have a wide variety of real estate to choose from, and are in the position to select offices with a high energy performance. The average energy label of the 10% of offices in the Netherlands that have an energy label is E [11]. This label corresponds with an operational energy performance of 1.49 GJ/m²·a for heating and cooling, lighting and hot tap water. Besides this market development, the Dutch government agreed that the Dutch government itself, responsible for around 20% of office space occupation in 2010 [12], only rents offices with minimum energy label C since 2010, which results in a higher energy performance of buildings [11]. Already a number of NGO's and companies have joined this agreement, and it is expected that more organizations will join this government agreement in the framework of Corporate Social Responsibility (CSR). As a result, many offices are renovated to improve their energy label to a minimum of C. In these renovations, the façade is often replaced to improve the operational energy performance of the building.

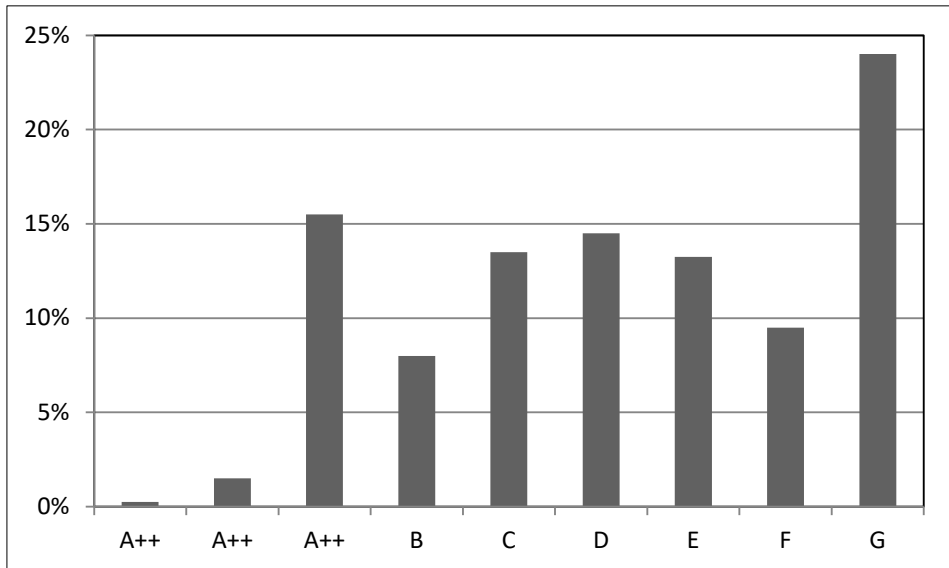

Figure 1. Energy label distribution in the Dutch office market 2010 [11].

Currently, a wide range of tools is available to calculate the operational energy performance of buildings, such as the Dutch standard Energy Performance Calculation Program [13], and VABI 114 [14].

But assessment tools, used to measure the environmental impact of buildings, should take both the energy aspect and the material aspect in such a way into account that the necessary insight is created in the total burden. Examples of these tools are BREEAM, LEED and the Dutch Greencalc+. In these tools, aspects such as energy and materials are combined with aspects such as management through a weighted combination of indicators [15].

These tools have a number of advantages, such as the distinction in the level of sustainability of a building compared to other buildings, providing a communication tool, encouraging stakeholders to define sustainability requirements, and providing a vehicle for policymaking [16].

However, in these tools energy and materials account for different shares in total building performance outcomes and different categories are applied. The different categories are divided into different subcategories and the grading of the subcategories depends on different quantitative and qualitative parameters. The parameters are based on performance and evaluation, while different system boundaries are used and different levels of detail are applied. Resulting in an outcome in which the level of sustainability for comparable buildings differs due to the different aspects and weighting [15]. According to Iwano et al, the measurements and the weights that should be given to the criteria are unresolved issues [17]. The outcomes in the end might show how the energy and/or material situation has improved, but create a

dilemma with regard to what the connection is between the outcome of the assessment tool and the actual environmental impact of the building.

Considering the material aspect, it is often only translated in embodied energy: the amount of energy necessary to process raw materials, modify materials and transport materials. Energy, embodied in buildings, may account for up to 60% of total life cycle energy [18]. Façades may account for up to 26% of total building embodied energy [19, 20]. The embodied energy in materials can be seen as a 'rebound effect' of energy performance improvement, and has in current practice a negative impact on the calculated operational energy performance improvement in household heating and cooling [21]. The same can be expected in office buildings. By calculating material consumption using only the embodied energy, the operational energy aspect and the material aspect are translated in a corresponding quantity; energy. For instance, Belgian residential low energy buildings with a primary energy consumption for heating of ca. 900 MJ/m³ building volume over 30 years have a total embodied energy of 1400 MJ/m³ building volume over 30 years, which is higher than the energy consumption for heating [22].

For embodied energy calculations various definitions, methodologies and system boundaries are used [18]. An example of the latter is that there is a distinction between methodologies in which only the amount of fossil based energy is part of the calculation as it is 'added' to the product, and methodologies in which the total amount of embodied energy, both fossil based and renewable based, which comes from 'natural sources' such as the sun, is calculated. Besides the different calculation methodologies, most results have uncertainties due to temporal, spatial and technical circumstances (location, weather, societal and energy generation), which are in many cases not shown in databases underlying the calculation tools [18]. A third aspect of embodied energy calculations is the varying system boundary of the calculation.

All these aspects have resulted in databases which face the problem of incompatibility and variation [18]. Besides these considerations, all embodied energy methods do not take into account the actual availability of resources, both renewable and non-renewable. As the extraction of construction materials increased significantly, it is worth exploring a method to be able to assess energy and materials equally. Due to the increase of material consumption and due to the associated increase of raw materials extraction more and more land is needed, with a negative impact on amongst others ecological systems, biodiversity and the reflectiveness of Earth (planetary albedo). In addition, raw materials which are necessary for the production of the building materials, such as copper, do not have an infinite stock. Besides land use required for extracting raw materials, there is also land needed for generating non-renewable and renewable energy to convert the raw materials in building materials or components and transportation of these building materials and components. As we have a limited amount of land and potential productivity of this land, it seems logical to base our consumption pattern on the land available for production and extraction of (building) materials, generation of energy, water production and food production.

In future, land necessary to produce renewable energy might compete with land necessary for food production and material production, which may lead to other choices in the design and realization of buildings [23]. Consequently, sustainability needs to be based on what can be generated and consumed in equilibrium within the system, implying an indicator based on the carrying capacity necessary to materialize and operate a function, instead of on impact calculations without any relation with the system itself [24]. The carrying capacity is the maximum persistently supportable load of a system [25], and can be indicated by the amount of land necessary to sustain the functioning of the system and the time this land is necessary, embodied land.

To calculate the embodied land, an assessment tool called MAXergy is under development [24]. The embodied land of a product (in $\text{m}^2\cdot\text{year}$) indicates the amount of land needed for the extraction of raw materials, the growth of materials, the generation of power, the recuperation of land, etc. in the Dutch situation [24, 26, 27]. The aim of the tool is to generate insight in the interaction of the energy and material aspect in buildings and relate the total impact of these impacts to the carrying capacity. In the methodology section this tool is further explained.

In this research, the relation between building environmental assessment tool outcomes and actual environmental impact is investigated. The energy and material aspects of three office façade renovation solutions are compared by using four different assessment tools in relation to the carrying capacity. A comparison is made between the situation before and after renovation of a south facing simulated office space with the different façade renovation solutions, covering the energy use of the building (operational energy), materials of the façade (embodied energy) and the related land use (embodied land) and compared with the outcome of a generic tool. Based on the comparison, a façade renovation solution with lowest environmental impact on carrying capacity has been calculated.

2. Methodology

The environmental impacts of three façade renovation solutions, realized in the Netherlands, have been investigated through a comparison of the outcomes of four different assessment tools before and after renovation.

For this research, a south orientated office space has been simulated in front of which different façade renovation solutions have been placed. The south facing façade has been selected because it is the building component which has the biggest effect on the annual cooling and heating load of a building in the Netherlands. The simulated space has a width of 8m, a length of 8m and a height of 7m. The simulated space consists of office spaces divided over two floors, because office spaces are the most relevant spaces in the buildings and the design of one of the selected projects is based on two floors. The selection of the three office façade renovation pro-

jects was based on availability and completeness of data and drawings and the sustainability ambitions in Greencalc +.

The following façade renovation solutions were selected:

- DHV office, Amersfoort; renovation during which the façade was totally replaced and the interior was preserved largely.
- WNF office, Zeist; renovation during which the façade was totally replaced and the building was partially demolished, stripped and refurbished.
- Central Post, Rotterdam; renovation of an existing post office, during which the façade was partially replaced.



Figure 2, 3, and 4. Impressions of the selected façade renovation solutions of the DHV, WNF and Central Post office buildings (source: vd Meijden).

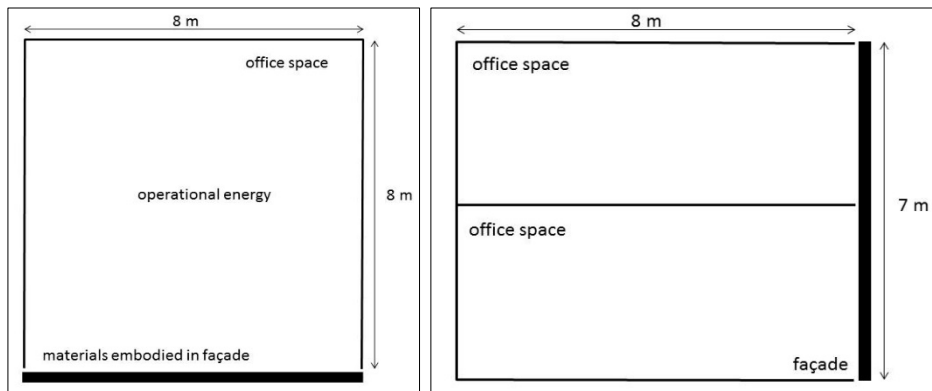

Figure 5 and 6. Floor plan and section of the investigated simulated south facing office space.

For each simulated space the same technical installations were applied for a relevant comparison of the influence of the façades on assessment tool outcomes. In all cases, only the material and energy aspect of the façade was taken into account. Building structure and architecture, services, lighting, interior components, economic, societal and user behaviour were out of the scope of this research to generate in depth insight in the relation between the energy and the material aspect, although these other aspects might have a substantial influence on building performance and impact [28]. For the calculations of the office façades a technical lifetime of 30 years [29] was chosen as reference. Energy and material aspects related to the pre-building phase as well related to the re-use phase and demolition phase were out of the scope of this research. In Table 1 an overview is given of materials used in the different façade renovation solutions.

Table 1. Overview of materials applied in the selected office façade renovation solutions.

Office	Materials
DHV	aluminium curtain wall; double pane argon filled glazing
WNF	wooden curtain wall, triple pane krypton filled glazing
Central Post	aluminium curtain wall; double pane argon filled glazing

The office façade renovation solution with lowest environmental impact in terms of embodied land has been further optimized using MAXergy, because this tool relates most closely to carrying capacity and assesses both the material and energy aspect and its interaction without weighting.

The following assessment tools / databases have been applied: VABI, ICE, Greencalc+, and MAXergy, and will be further introduced in the following sections.

2.1 VABI 114

VABI 114 [14] is a dynamic building simulation program in which the annual heating and cooling load in MJ can be calculated. VABI 114 generates in depth insight in the operational energy aspect in relation to the indoor climate. VABI 114 complies with national and international standards BRL 9501, BESTEST, EDR according to ISSO 54 and ASHRAE standard 140. In this research, the program has been applied to calculate the operational energy demand of the simulated space with different façades before and after renovation. The program only takes operational energy into account. Other aspects, such as embodied energy, are not embedded in the program, nor is the interaction between different aspects embedded.

2.2 ICE database

In this research, the "Inventory of Carbon & Energy" (ICE) database of the University of Bath [30] is selected to calculate the embodied energy of the different façade renovation solutions before and after renovation. The ICE database has been selected because the data corresponds most closely to the Dutch situation. The ICE database is an inventory of the embodied energy of materials data, originating from Life Cycle Analyses (LCA's), books and papers. In the embodied energy calculation there is no interaction with other aspects such as operational energy.

2.3 GreenCalc+ program

GreenCalc+ [31] expresses the sustainability of a building in an environmental index. The environmental index of a building (Milieu Index Gebouw - MIG) is based on a comparison of the environmental costs of material consumption, energy consumption, and water consumption with the environmental costs of a standard Dutch building realized in 1990. Greencalc+ has been applied to determine the overall building sustainability after renovation. By translating all aspects into one cost aspect they can be combined to one generic outcome and thus compared to other buildings. The determination of environmental costs of materials is based on CML-2, the LCA method developed by the University of Leiden, in combination with the Eco-indicator '99 method and the TWIN-model. The method of Müller-Wenk is used for the determination of transportation related noise disturbance. The determination of environmental costs is based on the Dutch standards NEN 2916: 2004 and NEN 5128:2004, complying with the Dutch standard Energy Performance Calculation. This calculation is through a LCA translated into environmental costs. For office buildings, the determination of water consumption is calculated with the Dutch 'Water Performance Standardisation'. This calculation is through a LCA translated into environmental costs. Although the impact of user mobility is calculated in Greencalc+, it is not part of the generic outcome. The user mobility is determined for office buildings by a calculation in an adapted version of the software program VPL-KISS [31]. Between the different aspects in Greencalc + there is no interaction or interrelation.

The standard reference building from 1990 has a value of 100 MIG. When a building is more sustainable than the reference building from 1990, then the value becomes above 100 MIG. Buildings with a MIG-value below 100 are less sustainable than a building realized in 1990. Although this tool indicates the relative improvement of environmental impact of a building compared with other buildings and with a building in 1990, it does not indicate clearly the actual impact on the environment.

2.4 MAXergy

MAXergy is a sustainability tool which expresses the energy and material impact of a project in the same physical quantity: embodied land. Embodied land is the amount of space and time necessary to fulfil the energy and the material demand for a certain function in a certain environment. Embodied land is expressed in $\text{m}^2\cdot\text{year}$ [26]. The embodied land of the different façade renovation solutions before and after renovation has been calculated using MAXergy. The total embodied land (EL) of a product is calculated using several databases as input the amount of new and recycled materials. The total embodied land calculation can be divided into direct embodied land (land and time required for the creation of a raw material), indirect embodied land (embodied energy converted into land and time) and operational energy (converted into land and time).

The embodied land for a building consists of three components, a. EL building, b. EL materials and c. EL operational energy, as indicated in figure 7.

- a. EL building indicates the land occupied by the building during its lifespan itself and can be directly derived from the design drawings in m^2 .
- b. EL for materials consists of two impacts: The primary impact indicates the time·land required to generate, produce and transport the material itself. The primary impact consists of the direct EL for material generation, and indirect EL for material production and transportation.
 1. The direct primary EL is calculated using a harvest database in which harvest/ m^2 are collected, depending on the origin of the material. The indirect primary EL is based on the ICE embodied energy database and through energy generation surface calculated (solar or fossil based) [30]. The input needed to calculate both direct and indirect primary EL is the mass of the building material (kg) and energy generating device efficiency.
 2. The secondary impact indicates the time·land required to generate and produce the techniques and installations necessary to generate the materials; e.g. the photovoltaic panels required to generate the necessary embodied energy. The tertiary impact and other possible relevant impacts, such as operational transportation energy, are not taken into account [32]. The input needed to calculate the secondary EL is both the mass of materials used in the installations (kg) and installation efficiency (W/m^2).
- c. EL operational energy consists of the land necessary to generate the energy using solar energy (PV/ solar thermal) or fossil resources and the EL necessary for the generation, production and transportation of the materials used for the energy generating devices.

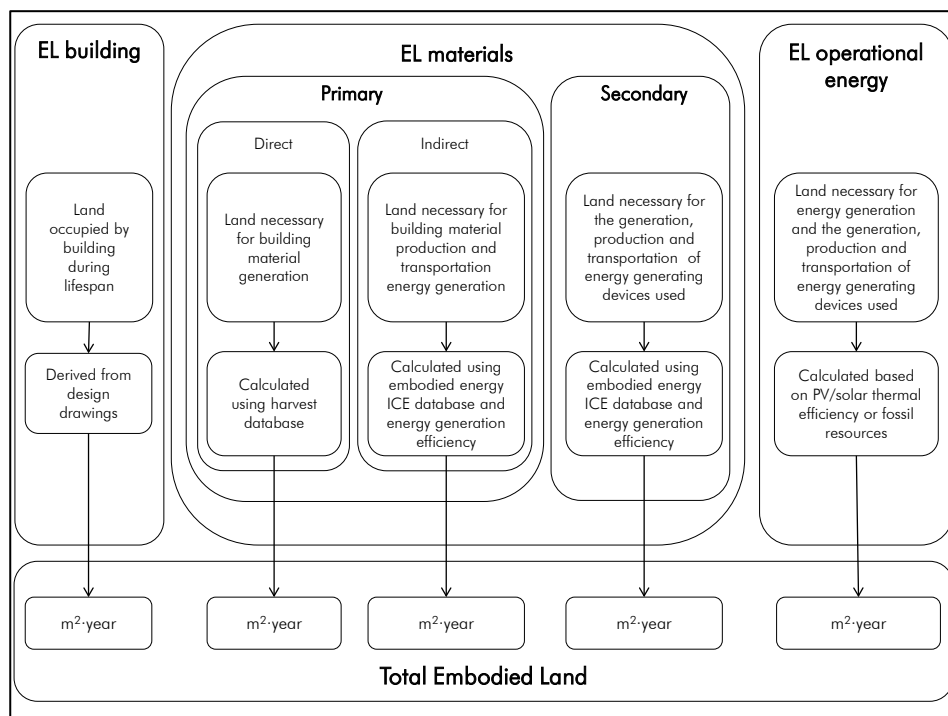

Figure 7. Schematic overview of the proposed embodied land calculation method for a combined environmental assessment of energy and materials in the built environment.

These tools and databases were selected to generate in depth insight in the operational energy and material aspect (VABI 114 and ICE database), and to be able to compare these results with a widely used generic tool in the Netherlands (Green-calc+) of which the data of all cases was available, and to be able to relate this to the carrying capacity (MAXergy).

3. Results

In the following section, the calculated results of the different applied assessment tools / databases; VABI 114, ICE database, Greencalc+ and MAXergy are presented. In section 3.2.1 the results of VABI 114 and the ICE database are combined.

3.1 VABI 114

Figure 8 shows the results of the annual cooling and heating load of the simulated office space with different façade solutions before and after the renovation, calculated with VABI 114. The heating and cooling load of all three cases after the renova-

tion is similar. The cooling load of the investigated south orientated space is in all buildings the largest energy factor both before and after the renovation. The renovation of the façade has mainly impact on the heat load of the building, which is strongly reduced after the renovation. This is achieved by increasing the Rc value of the façade through the application of materials with higher values of thermal insulation and the application of double pane argon filled glazing or triple pane krypton filled glazing.

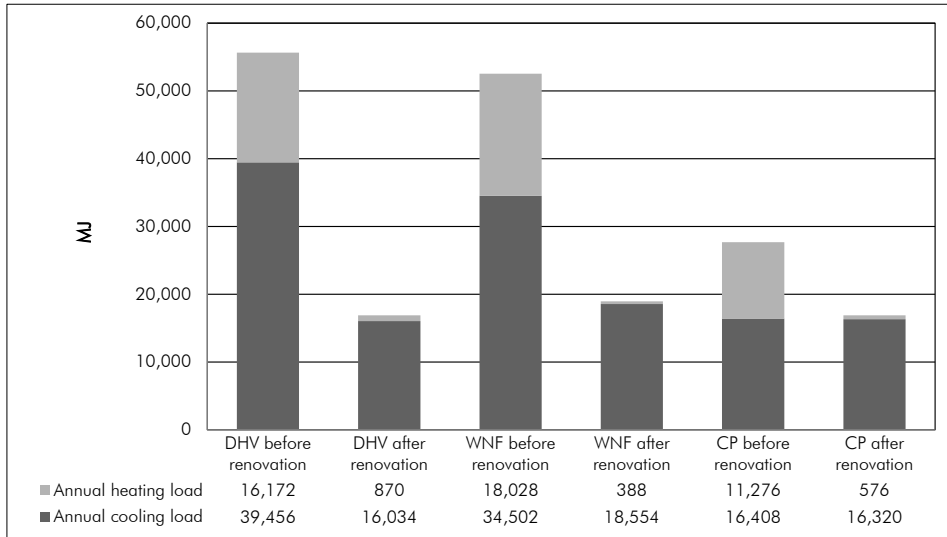

Figure 8. Annual operational energy load consisting of heating and cooling of the simulated south facing office space with façade solutions before and after renovation.

3.2 ICE database

Figure 9 shows the results of all embodied energy calculations of the different façade solutions before and after the renovation. The embodied energy required for the façades of the DHV office and the WNF office after the renovation is many times higher than the embodied energy of the façades before the renovation. After renovation, the DHV office has a new aluminium curtain wall with double pane argon filled glazing and the WNF office has new wooden curtain wall with triple pane krypton filled glazing. The embodied energy required for the new façade of the Central Post building is relatively small compared to that of the other buildings. This is because this façade was only partly replaced and remained largely unchanged. Furthermore, the embodied energy required for the original façade was already very high due to the large amount of the materials applied, such as concrete and steel. The existing aluminium façade with single glazing is replaced by a new aluminium façade with double pane argon filled glazing.

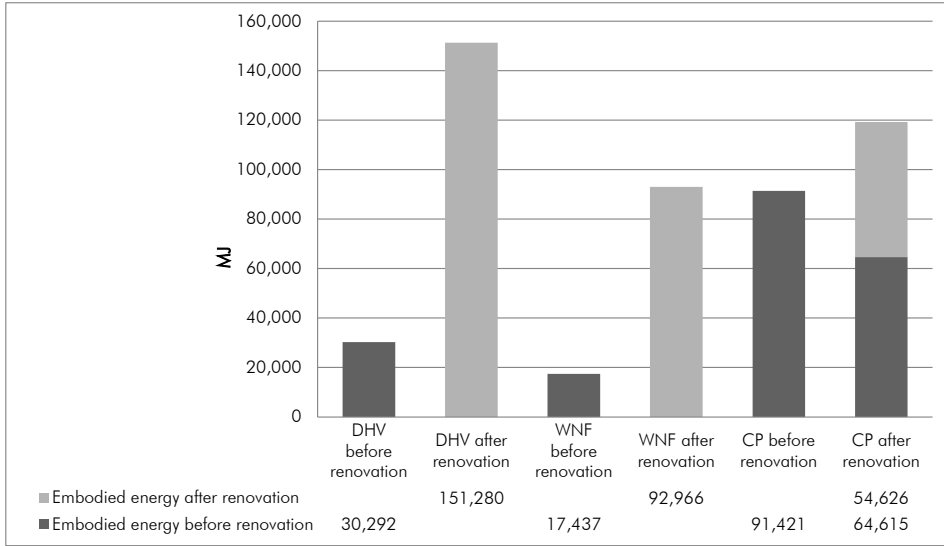

Figure 9. Total embodied energy of the façade solutions before and after renovation.

3.2.1 Combination of VABI 114 and ICE database

In Fig. 10 the results of total energy consumption calculations are shown (operational energy of the simulated office space and the embodied energy of the façade) before and after the renovation, for a total technical lifetime of 30 years. The results indicate that, for the investigated south facing office space, the cooling load has the largest energy impact, both before and after the renovation. It also shows that the heat load of the office space has decreased significantly after the renovation, which is the result of the improved thermal properties of the façades after the renovation. To achieve these improved thermal properties more embodied energy is required for the façades. In general the embodied energy of the façades increases after renovation, but the cooling load remains the largest energy demand for this south facing office space.

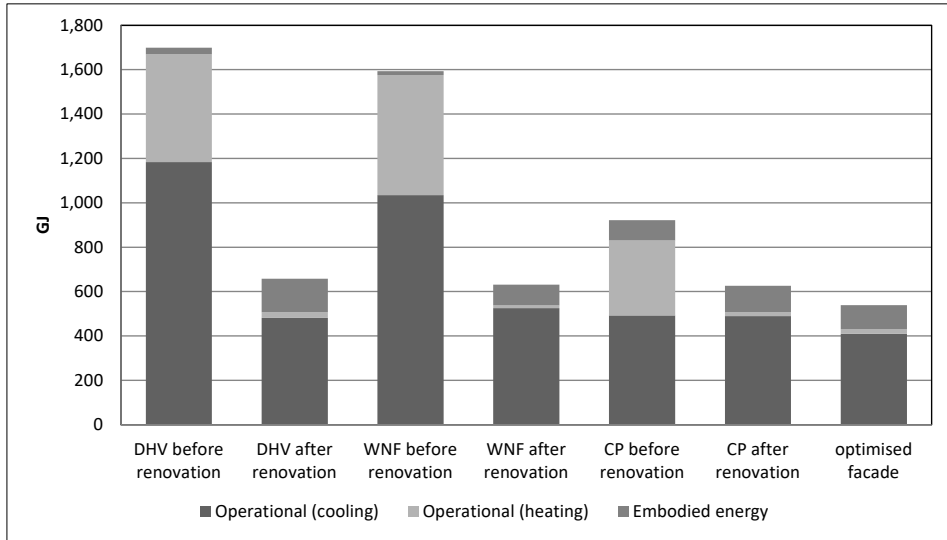

Figure 10. Total energy performance of the simulated south facing office space with façade solutions before and after renovation, over 30 years.

3.3 GreenCalc+

The results of all renovation projects in table 2 show a final score above 200 and all projects score both in the field of energy performance and material consumption an A, which is good. In the results there is no difference between the various projects in the field of energy performance and material consumption. The WNF office has the highest total score, because the building generates energy with photovoltaic (PV) panels.

Table 2. Greencalc+ score of all renovation projects¹.

	DHV office	WNF office	Central Post office
Material	A	A	A
Energy	A	A	A
Water	E	F	G
Total	239	269	252

¹ The WNF and Central Post office have only a small difference in outcome.

3.4 MAXergy

Figure 11 show the calculated embodied land of façade materials and the calculated embodied land of operational energy of the simulated office space when all energy required for the operational energy is based on fossil fuels. Fossil fuels have a significant larger EL that renewable fuels due to the large amount of land and large span of time necessary to generate these fuels [23]. Due to this, the embodied land of the operational energy is the determining factor compared with the embodied energy for the materials of the façade. Only the results of the WNF façade solution show a different situation where the material use is the determining factor. This is because after the renovation operational energy in this building is generated by solar energy.

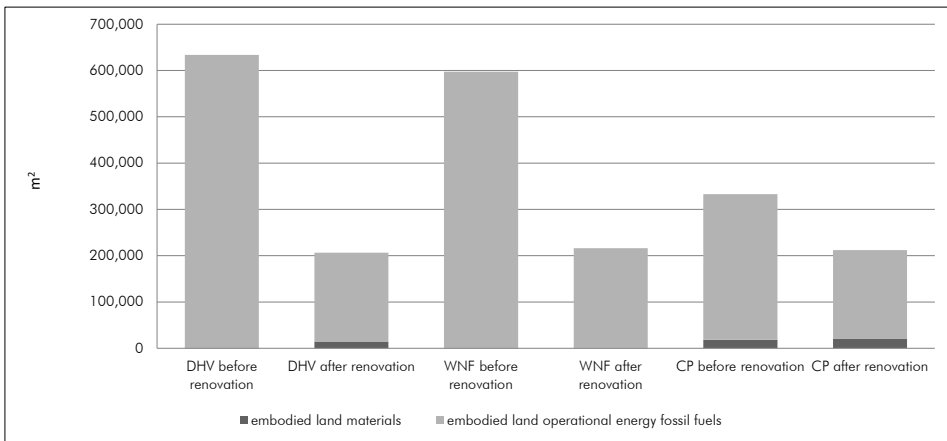

Figure 11. Total embodied land in m^2 of the simulated south facing office space with different façade solutions before and after renovation based on fossil fuels, over 30 years.

Figure 12 shows the embodied land calculations of the simulated office space with different façade solutions before and after renovation, over 30 years, when all energy is generated by solar energy (solar panels and solar collectors). In this calculation, the total embodied land for all solutions is much smaller than with a similar calculation using fossil fuels, due to the large time-land impact to generate fossil fuels. Secondly, the embodied land for the façade materials is much greater than the embodied land for the operational energy. The embodied land of the operational energy is in most cases negligible compared to the embodied land of the façade materials.

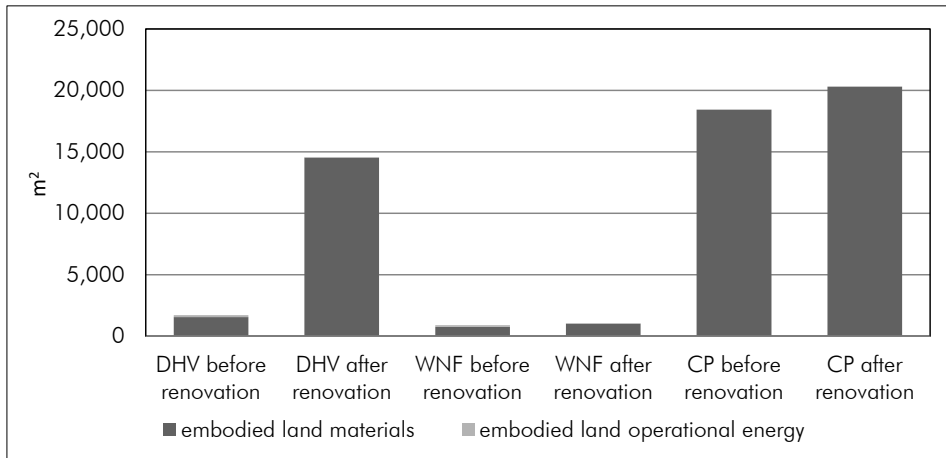

Figure 12. Total embodied land in m² of the simulated south facing office space with different façade solutions before and after renovation based on solar energy, over 30 years.

The results show that the WNF office façade solution after renovation scores very good in comparison with the other façades. This façade consists mainly of wood, a natural material with low embodied energy. Natural (bio-based) materials score very well in the embodied land calculation, because these materials can grow back naturally by themselves, so a closed-loop system is created without adding energy.

A closed-loop system for the materials is created when a material that is used as a building product has grown back within the lifetime of the façade, and all energy to realize the building product has been regenerated. The aluminium, concrete and steel that are used in the DHV and the Central Post Office façade solutions are not bio-based and cannot grow back. These materials are however recyclable and partially reusable. The recycling percentages of these materials are not 100%, for aluminium it is for instance 94% [33]. According to the MAXergy calculation a lot of energy is needed to win back the non-recycled percentage of these materials.

4. Calculation of a façade renovation solution with lowest environmental impact on carrying capacity.

Based on the results presented in section 3, the WNF façade solution has been further investigated and its environmental impact has been further minimized using MAXergy. As indicated in the preceding sections, using only energy related calculations or using a generic assessment tool does not offer a comprehensive carrying capacity based indicator of the environmental impact of a building. Analysis of the materials applied in the WNF façade solution (figure 13) shows that most of the embodied land of the façade originates from non-bio-based materials, such as steel and aluminium.

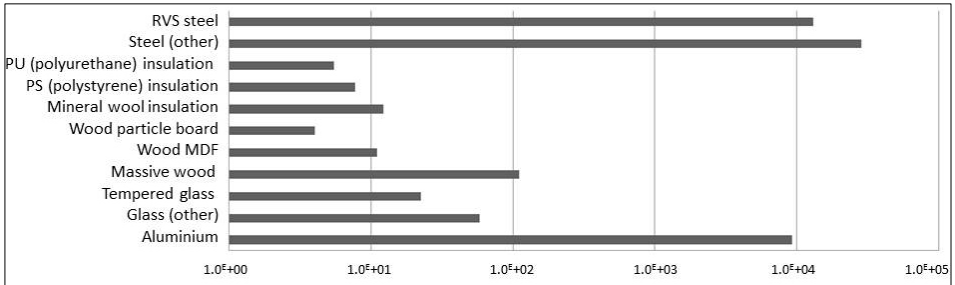

Figure 13. embodied land of different materials in the WNF façade solution in m²·year.

Based on this analysis a comparison has been made between four façade solution versions to investigate the embodied land minimisation as a result of the interaction of the material and energy aspect. In figure 14 an overview is given of these versions:

- The façade after renovation with a certain amount of material related EL, mainly due to non-renewable materials, and a certain amount of operational energy related EL;
- Minimisation of material related EL while maintaining the same operational energy related EL resulting in a façade in which the actual openings are maintained and thermal insulation is maintained, but all materials are 100% bio-based.
- Minimisation of material related EL, resulting in a façade consisting of a plywood sheet and no openings.
- Minimisation of operational energy related EL with high insulation values for the opaque façade components ($R_c = 10 \text{ m}^2 \cdot \text{K}/\text{W}$).

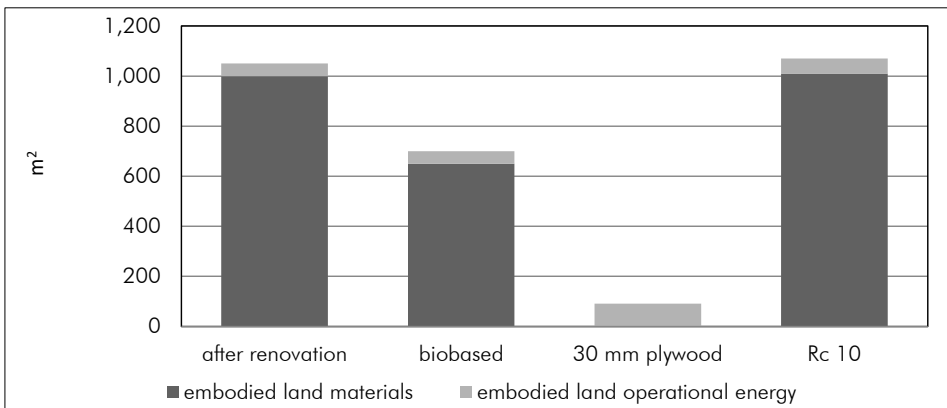

Figure 14. Total embodied land in m² of the simulated south facing office space with different façade solution versions based on solar energy, over 30 years.

In all versions the embodied land of the materials is still larger than the embodied land of the operational energy, indicating the importance of material consumption in this assessment method. Even when the façade consists of only a minimal amount of bio-based materials (only a 30 mm plywood sheet), the embodied land required for the operational energy is small.

Within the boundaries of the Dutch Building Regulation, a minimisation of environmental impact of the façade renovation solution has been investigated. The Dutch Building Regulations indicate the following for this office façade calculation:

- Insulation value for opaque façade parts $R_c 3.5 \text{ m}^2 \cdot \text{K}/\text{W}$.
- U value transparent façade parts $U 2.2 \text{ W}/\text{K}\cdot\text{m}^2$.
- 2m^2 transparent façade surface per office floor.

Within these boundaries a maximum use of bio-based materials is investigated. Non bio-based materials, like metals, need to be recycled as much as possible. The façade design consists for 93% of bio-based materials, in which the metal components have been replaced by fibre-reinforced composites. Even the design of window placing is realized without metal components (figure 16). Resulting in a façade solution that needs a total of 304 m^2 embodied land for a lifespan of 30 years, which is a reduction of 70% compared to the actual WNF façade renovation solution. In addition, in the design is taken into account that the building components are easy to separate, increasing the possibilities for re-use and recycling. The collateral effect of this minimization of embodied land is a solution with disputable architectural quality, compared to the realized WNF office façade renovation design (figure 16).

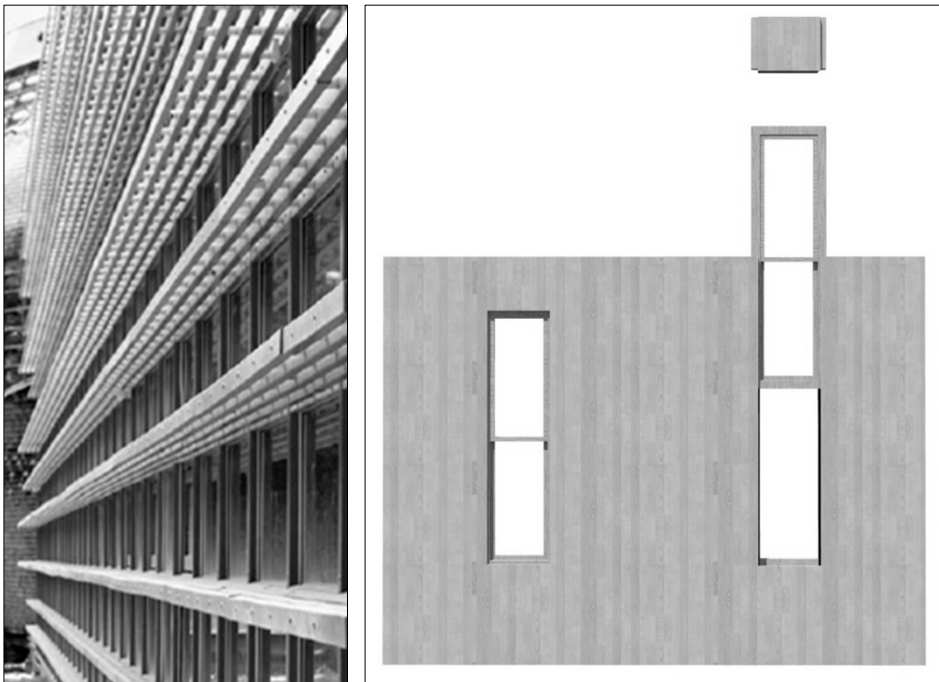

Figure 15 and 16. Picture of the realized WNF façade renovation and the calculated office façade renovation with minimal embodied land (source: vd Meijden).

5. Conclusions & discussion

Based on the comparison of the simulated south facing office with different façade renovation solutions and the calculation of a façade renovation solution with minimal environmental impact based on carrying capacity, the following conclusions concerning operational energy performance, material performance and the related embodied land are drawn.

- This research indicates that in the simulated cases operational energy efficient façade renovations result in a decrease of operational energy and an increase of embodied energy in the façade. Assessment tools based either on one aspect such as operational energy or on only energy related aspects or resulting in a generic outcome do not generate insight to lower the actual total environmental impact.
- In all cases, the cooling load is the largest energy part of total energy demand, both before and after the renovation and the embodied energy of the façades is a small portion of the total energy demand, over a lifespan of 30 years, considering only a south facing façade. These results would presumably be different when the complete building would be taken into account and when other orientations of the façade would be investigated.
- Not only the amount of materials but also the choice of materials determine the embodied energy and embodied land of the façade.
- In the case of the WNF façade solution, the building itself generates after the actual renovation to a high extend its own energy through photovoltaic (PV) panels on the roof. If in this case the operational energy would not be included in the calculation and the PV panels would be included in the material calculation, the total energy consumption of the building would consist solely of embodied energy. Material consumption would in this case be the determining factor in environmental impact.
- The embodied land calculations based on fossil fuels show in almost all cases that the operational energy is the determining factor compared to materials. An exception is the WNF office façade solution after the renovation because in this case the operational energy of the building is generated on site. In this situation, the material aspect becomes the determining factor in environmental impact.
- The calculated office façade renovation solution indicates that the amount of materials and the choice of materials determine the environmental impact in nearly all situations. Bio-based materials, such as wood, score very well in this calculation because the low amount of embodied energy and renewability. Further research is suggested to compare the façade versions using other tools, and base façade versions on these tools.
- It can be concluded that in a combination of embodied and operational energy based on fossil fuels, the material aspect determines the environmental impact in

the case of *nZEBs*, such as the WNF building, emphasizing a tool in which the material aspect and energy aspect are non-weighted assessed, and the MAXergy tool offers this possibility.

Based on this research project, the following conclusions concerning the MAXergy tool are drawn to suggest further research in this direction.

- The energy related embodied land calculation in MAXergy is based on the surface of solar panels and solar collectors, which is necessary for generating electricity and heat. The results of the embodied land calculations are therefore highly dependent on the efficiency of the solar panels and solar boilers used for this.
- Operational energy is in an increasing number of buildings generated with renewable sources, but the majority of embodied energy is not. Therefore, a comparison is made between the land use by means of fossil energy and solar energy. Further research into impact by using the current energy mix (fossil fuels, nuclear and renewable energy) is recommended to generate insight in the actual energy related embodied land of materials.
- An important part of the MAXergy calculation is the recovery of raw materials such as metals. In many cases this is the decisive factor for the final result. For the recovery of metals for example a method is chosen, in which metal particles are filtered from seawater. This includes a number of assumptions. Further research should be done on the recovery of metal particles.
- As the MAXergy tool aims at relating the combination of material consumption and energy performance of a building to the carrying capacity of a system it offers the possibility to generate insight in building performance from a perspective related to our planet. But as the tool is based on existing embodied energy data, the same discussions concerning availability of data, the bandwidth of results, etc. are relevant and further research should be conducted in order to generate more reliable outcomes related to the carrying capacity.

References

1. IEA, *Worldwide trends in energy use and efficiency*. 2008.
2. Ko, J. and L. Widder. *Building envelope assessment tool for system integrated design*. in PLEA 2011. 2011. Louvain-la-Neuve, Belgium.
3. Pérez-Lombard, L., J. Ortiz, and C. Pout, *A review on buildings energy consumption information*. *Energy and Buildings*, 2008. 40(3): p. 394-398.
4. U.S.E.I.A., *International Energy Outlook 2011*. 2011.
5. Bruckner, M., et al., *Materials embodied in international trade – Global material extraction and consumption between 1995 and 2005*. *Global Environmental Change*, 2012. 22(3): p. 568–576.
6. European Commission, *Directive 2010/31/EU of the European Parliament and of the Council of 19 May 2010 on the energy performance of buildings (recast)*, E. Union, Editor. 2010.
7. AgentschapNL, *Nationaal Plan voor het bevorderen van bijna-energie neutrale gebouwen in Nederland*. 2012.
8. Torcellini, P., et al., *Zero Energy Buildings: A Critical Look at the Definition*, in ACEEE Summer Study. 2006, NREL: California.
9. Ramesh, T., R. Prakash, and K.K. Shukla, *Life cycle energy analysis of buildings: An overview*. *Energy and Buildings*, 2010. 42(10): p. 1592-1600.
10. Zadelhoff, D., *Nederland compleet; kantoren en bedrijfsruimtemarkt*. 2013.
11. AgentschapNL, *Onderzoek naar het energie- en CO2-reductiepotentieel*, in *Duurzaam inkopen van gebouwen, de Rijksgebouwendienst als voorbeeld*. 2010.
12. AgentschapNL, *Rapport energiecijfers kantoren*. 2010.
13. N.N.i., *NEN EPW NPR 5129+A2:2010v2.2 Energieprestatie van woonfuncties en woongebouwen - Rekenprogramma (EPW)*. 2010.
14. VABI. *VABI 114 website*. 2013; Available from: <http://www.vabi.nl/Producten/Vabi-Uniforme-Omgeving/Gebouwsimulatie>.
15. Häkkinen, T.e., *Sustainability and performance assessment and benchmarking of buildings - Final report*. 2012, VTT: Espoo.
16. Tran, H.T. *measuring sustainability: carbon or land?* in iNTA-SEGA. 2009.
17. Iwaro, J., et al., *An Integrated Criteria Weighting Framework for the sustainable performance assessment and design of building envelope*. *Renewable and Sustainable Energy Reviews*, 2014. 29(0): p. 417-434.
18. Dixit, M.K., et al., *Need for an embodied energy measurement protocol for buildings: A review paper*. *Renewable and Sustainable Energy Reviews*, 2012. 16(6): p. 3730-3743.
19. Yohanis, Y.G. and B. Norton, *Life-cycle operational and embodied energy for a generic single-storey office building in the UK*. *Energy*, 2002. 27(1): p. 77-92.
20. Thormark, C. *Energy and resources, material choice and recycling potential in low energy buildings*. in *CIB conference SB07 Sustainable Construction, Materials and Practices 2007*. Lisbon, Portugal.
21. Herring, H.S., *Steve, Energy Efficiency and Sustainable Consumption*. *Energy, Climate and the Environment Series*, ed. D. Elliott. 2009, Hampshire, England: Palgrave Macmillan.
22. Verbeeck, G. and H. Hens, *Life cycle inventory of buildings: A contribution analysis*. *Building and Environment*, 2010. 45(4): p. 964-967.
23. Rovers, R., et al. *designing for only energy: suboptimisation*. in PLEA 2011. 2011. Louvain-la-Neuve, Belgium.
24. Rovers, R. *0-material building: space time analyses*. in SB10. 2010. Maastricht, the Netherlands.
25. Catton Jr, W.R., *The Gaia atlas of planet management: for today's caretakers of tomorrow's world: N. Myers (general ed.), 272 pp., 1985, Pan, London, £9.95*. *Journal of Rural Studies*, 1986. 2(2): p. 170-171.
26. Rovers, R., *MAXergy and embodied land*, RiBuiT, Editor. 2011.
27. Rovers, V., et al., *Maxergy, duurzaamheidsberekening op basis van landgebruik*. 2011, RiBuiT / Zuyd University of Applied Sciences.

Chapter 3

28. Stephan, A., R.H. Crawford, and K. de Myttenaere, *Towards a comprehensive life cycle energy analysis framework for residential buildings*. *Energy and Buildings*, 2012. 55(0): p. 592-600.
29. Ebbert, T., *Re-Face: Refurbishment Strategies for the Technical Improvement of Office Facades*. 2010, Delft University of Technology: Delft.
30. Hammond, G.J., C., *Inventory of Carbon and Energy (ICE)*. University of Bath, UK, 2008.
31. Greencalc+. *Greencalc+ website*. 2013; Available from: <http://www.greencalc.com/>.
32. Stephan, A., R.H. Crawford, and K. de Myttenaere, *A comprehensive assessment of the life cycle energy demand of passive houses*. *Applied Energy*, 2013. 112(0): p. 23-34.
33. Haas, M., *NIBE's basiswerk milieuclassificatie*. 2002.

Chapter 4

Environmental impact evaluation of energy saving and energy generation: case study for two Dutch dwelling types.

This chapter was published as:
Ritzen, M.J., Haagen, T.H.J., Rovers, R., Vroon, Z.A.E.P. & Geurts, C.P.W.: *Environmental impact evaluation of energy saving and energy generation: case study for two Dutch dwelling types*. Building and Environment, vol. 108, pp. 73-84, 2016

Abstract

The existing building stock is a logical target to improve the level of sustainability of the built environment by energy saving measures. These measures typically entail a decrease of operational energy demand, mainly by adding building components such as insulation packages and energy generating devices. Consequently, material related environmental impact might create a collateral disproportionate burden, which is not well addressed in current assessment methods. In an attempt to evaluate this effect, two common dwelling types in the Netherlands, a terraced and a detached dwelling, have been redesigned to the level of Zero Energy Building in four scenarios, and the environmental impact of these scenarios has been assessed, expressed in embodied energy and related to the carrying capacity, expressed in embodied land ($\text{m}^2 \cdot \text{a}$). The lowest environmental impact is achieved in the scenario with an average U-value of $0.29 \text{ W/m}^2\text{K}$ and 35 m^2 and 75 m^2 of PV modules for the terraced and the detached dwelling, respectively. In this scenario, added embodied energy is 3.4 GJ/m^2 and embodied land is $308,777 \text{ m}^2 \cdot \text{a}$ land for the terraced dwelling and 5.2 GJ/m^2 and $653,644 \text{ m}^2 \cdot \text{a}$ land for the detached dwelling. This evaluation indicates that a focus on only energy efficiency improvement shows a collateral material related environmental impact which should be embedded in the complete environmental assessment of buildings.

1. Introduction

Worldwide, the consumption of energy and material resources is increasing significantly to maintain, and even improve, our standards of living. Between 1973 and 2012 the global final energy consumption increased from 4,672 Million tons of oil equivalent (Mtoe) to 8,979 Mtoe and is expected to grow to 12,001 Mtoe in 2035 [1]. 20% to 40% of this global final energy consumption is attributed to the built environment, more than 86% of this consumption is based on fossil fuels [2].

In the Netherlands, the residential sector accounts for approximately 17% of the total primary energy consumption [3]. The residential energy consumption consists of 74% natural gas and 2.5% renewable energy sources, 18.9% of which is solar energy [4].

Global developments such as the depletion of fossil fuels, climate change and social-economic issues, emphasize the need to improve energy efficiency. In this respect, targets have been set in the European Union (EU) to achieve a lower overall energy consumption in the built environment and to decrease dependency on fossil fuels. Being a main agent, buildings are crucial towards achieving the EU objective of reducing greenhouse gas emissions by 80-95 % by 2050 compared to 1990 [5]. The EU Energy Performance Building Directive (EPBD) requires all new buildings to be nearly Zero Energy Buildings (*nZEB*) by the end of 2020 and existing buildings should be *nZEB* in 2050 to meet European targets [6, 7]. A *nZEB* has a very high energy performance and the very low remaining amount of energy required should be covered to a very significant extent by energy from renewable sources, produced on-site or nearby [6]. The implementation in legislation of *nZEB* in the EU leaves room for interpretation on a member state level. In a Zero Energy Building (*ZEB*) all necessary energy is generated on site based on renewable sources, possibly by means of connection to a storage medium or the grid for balancing over days, seasons or the year [8-10], however consensus on EU level is still to be developed on the exact definition. There are a number of long-term advantages of a *ZEB*, such as lower operating and maintenance costs, better resilience to natural disasters, better resilience to power outages and a higher level of energy security [10]. Considering the EU economy, renovation of existing buildings is a win-win option because it has implications for growth and jobs, energy and climate and cohesion policies [11].

A *ZEB* can be realized by lowering the energy demand of the building, for instance through better insulation, and by generating energy at the building scale, for instance by solar energy systems. Both strategies have implications for the building envelope as this is the building part that determines heat losses and gains and also provides the necessary area for the installation of solar energy systems [12, 13]. Solar energy is seen as one of the most promising alternative sources to meet our energy demands [14]. However, for the realization of higher insulation levels of for the realization of solar energy systems, materials are needed. Worldwide, 50% of all extracted materials are used in the built environment [15], and the extraction of

building materials has increased with 30% between 1995 and 2005 [16]. In general, buildings have a linear pattern of resource consumption resulting in disposal ('from cradle to grave'), without qualitative or quantitative recycling or re-use of these resources [17]. In a linear pattern, raw materials are extracted and used in the realization and operational phase, after which they are mostly not re-used at all in the decommissioning phase, or are used at lower quality levels, called *down-cycling*. This may not cause a deficit of resources if all these materials are renewed or renew themselves in their effective lifespan. At this moment, many countries import more materials than they produce themselves [18]. This might lead to an intensified international competition for raw materials [16]. Design philosophies such as *Cradle to Cradle* and the *Circular Economy*, attempt to adapt the linear process into a circular one by re-using or recycling materials [19, 20].

One of the indicators in the field of environmental assessment is embodied energy; the amount of energy necessary to process raw materials, modify materials and transport materials [21-24]. In this way, the operational energy and the embodied energy in materials can be evaluated at the same scale.

For instance, extremely low energy buildings have a total of ca. 900 MJ/m³ for heating over 30 years and have a total of 1400 MJ/m³ embodied energy, indicating the share of materials in the environmental assessment with this indicator [23, 25]. Other recent studies show the significance of increased embodied energy due to the addition of insulation materials and installations [22].

In most buildings, embodied energy is seldom evaluated, or only evaluated after completion, and to date there appears to be no universal methodology to assess the total embodied energy of a building [21, 26, 27]. Current embodied energy databases show a large bandwidth of results for the same materials, among others due to the different calculation methodologies [21]. This is illustrated in Figure 1, in which the embodied energy per m² is shown for different buildings and different climatic zones, ranging between 3.6 and 8.8 GJ/m² [22].

Furthermore, embodied energy is not considered in both the EPBD and the Dutch energy agreement for sustainable growth [28]. Hence, being more energy efficient in the built environment might prove to be deceptive when following current policies and tools including embodied energy based on Life Cycle Assessment (LCA). However, it could be argued whether calculating all aspects into only energy generates the needed insight in the environmental impact of buildings.

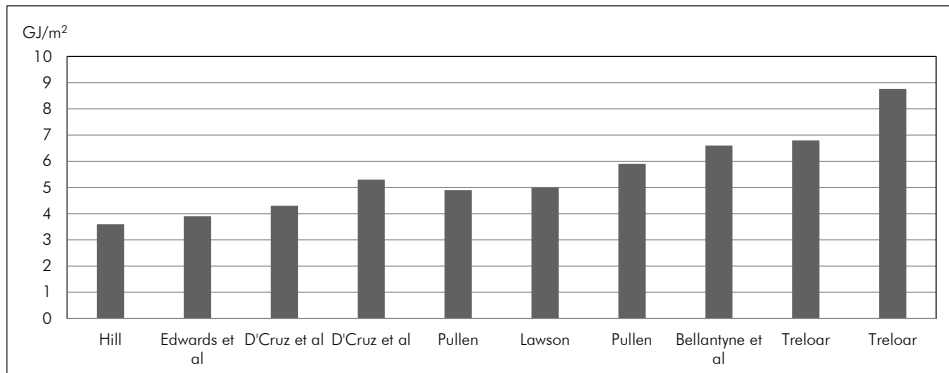

Figure 1. Differing embodied energy values (GJ/m²) in different investigations in residential buildings (cited from [22]).

On the track towards ZEBs, the performance of building materials will become more important because they create the only environmental impact once the operational energy will be completely generated on site, and therefore they should be part of the assessment [29, 30]. Because both materials and energy interact and influence the final environmental impact of a building, a joint evaluation is necessary. Thus, the environmental assessment should generate insight in the level of sustainable production of materials, and not only in energy, which can be related to the carrying capacity and expressed in land footprint [31]. In future, land necessary to produce renewable energy might compete with land necessary for food production and material production, which may lead to other choices in the design and realization of buildings [32].

In the Netherlands, the dwelling stock has a turnover smaller than 1% each year, complying with the energy performance regulations, making the existing building stock one of the key sectors where action is needed to meet energy efficiency goals [33-36]. As the focus on energy efficiency has mainly emerged after the first oil crisis in 1973, many dwellings, especially from before this time, are characterized by poor energy efficiency. 58% of Dutch dwellings are built before 1975 [37]. As many of these dwellings are still technically and socially adequate for housing, ways for sustainable renovation are being investigated [38]. The quest is to find the optimum between reduction of energy demand and generation of energy demand, in terms of lowest environmental impact of energy performance and material consumption [39]. Until 2012, in approximately 17% of the existing Dutch dwelling stock energy efficiency improvement measures have been realized to decrease energy consumption with 20% - 30% [40].

To investigate the combined environmental impact of energy performance and material consumption, expressed in two indicators, embodied energy and embodied land. The environmental impact is assessed of four successive renovation scenarios of insulation levels and associated surface of PV modules for two existing dwelling

types in the Netherlands. The dwelling types are the terraced dwelling built between 1946-1964 and the detached dwelling built before 1964 [36, 37] due to the large energy consumption and large number of these dwelling types. The insulation packages are based on 100% renewable materials to minimize material related environmental impact. The environmental impact of the original state of the dwelling types itself is outside the scope of this study. The environmental impact is related to the carrying capacity - the amount of land-time necessary to create the materials used for both energy saving and energy generation, based on the MAXergy methodology [41, 42], the BINK tool [43] and the ICE database on embodied energy [44]. The impact indicator of carrying capacity based on the MAXergy methodology is expressed in Embodied Land (EL) in m^2a .

2 Methodology

For two typical Dutch dwelling types, four ZEB renovation scenarios have been developed. The dwelling types are described in chapter 2.1 and the four renovation scenarios are further described in chapter 2.2. To assess the environmental impact of the different renovation scenarios for both dwelling types, the following calculations have been carried out in sequence:

- Firstly the operational energy demand for heating, cooling, ventilation, and lighting has been calculated using the BINK software tool and the PVGIS software tool has been used to calculate the amount of PV modules necessary to generate the operational energy demand for the different scenarios[43, 45]. The BINK software tool is used in the Dutch construction industry to indicate if a building project complies with energy efficiency regulations. In this study, the software is only used to indicate the energy consumption in the building, not taking national standards into account. PVGIS is a widely applied software tool developed by the Joint Research Centre of the European Commission.
- Secondly, the mass and the embodied energy have been calculated of based on information from the material supplier [46], the ICE database developed by the University of Bath [44], and previous research conducted by Zuyd University [41, 42].
- Thirdly, the carrying capacity related impact of all insulation packages and associated surface of PV modules has been calculated using the MAXergy methodology. MAXergy relates the environmental impact to global carrying capacity, based on the urban harvest method [47, 48]. In MAXergy, the energy and materials impact can be calculated and expressed in an unit called embodied land, defined as the land over time required to restore the consumed resources [49]. The land-time necessary to generate a source (either materials or energy) is a parameter to measure energy and materials on a same scale. In MAXergy, a selection of data

from large international databases such as the ICE database of the University of Bath and data from international publications are used for the impact calculations [44].

2.1 Dwelling types

On a regular basis, the governmental Dutch Enterprise Agency (RVO.nl) of the Ministry of Economy, Innovation and Agriculture publishes a document of example dwellings in The Netherlands [37]. The document distinguishes between 7 types of Dutch dwellings, indicated in Table 1, with categories corresponding to the building period. For this research, two dwelling types with very low energy efficiency have been selected; the terraced dwelling type built between 1946 and 1964 and the detached dwelling type built before 1964. In the Netherlands, 42% of all dwellings are terraced dwellings and 41% of primary energy is consumed in this type. Within this number of dwellings, mostly row houses, large-scale repetition is common and resulted in communities with a large number of exactly the same dwellings. With about 14% of all dwellings, the detached dwelling type is smaller in number, but shows the second largest primary energy demand with 24%. The two types combined account for 56% of the Dutch dwelling stock and for 65% of the total primary energy demand in the Dutch dwelling stock.

Table 1. Number of dwellings and annual primary energy demand of the distinguished dwelling types in the Netherlands (based on [37]).

Type	Number of dwellings	Percentage of total	Annual primary energy demand (TJ)	Percentage of total
Detached	959,000	14%	153,361	24%
Semi-detached	824,000	12%	94,012	15%
Terraced	2,839,000	42%	260,187	41%
Duplex apartment	382,000	6%	33,621	5%
Gallery apartment	465,000	7%	20,788	3%
Tenement apartment	847,000	12%	45,476	7%
Other apartment	485,000	7%	22,070	4%

The example dwelling publication gives specific characteristics for dwellings from each building period, based on medians from governmental research in which the energy performance of 5,000 existing dwellings was identified [50]. In order to use the example dwelling data as initial input for this research and to eventually be able to calculate the overall improvements for the existing Dutch dwelling stock, the research focuses on a subcategory for both a detached and a terraced dwelling. Fig. 2 distinguishes between the dwelling types according to the building period and shows the total annual primary energy demand per dwelling subcategory (TJ).

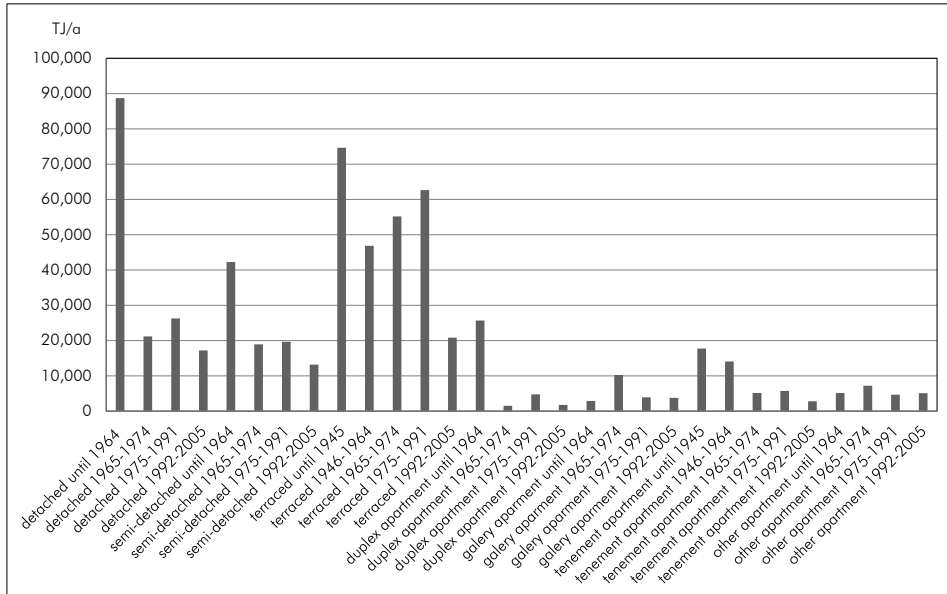

Figure 2. Annual total primary energy demand per dwelling subcategory based on construction period (TJ) [37].

In this study, the following 2 example dwellings are taken as the representation of the dwelling type. In practice, there is a large variety in the dwelling types, covering orientation, roof inclination, window and door sizing, etc.

2.1.1. Detached dwellings

The subcategory detached dwellings built before 1964 exceeds the other detached dwellings with 58% of the total energy demand within the category detached dwellings, due to the poor energy efficiency. Furthermore, the detached example dwelling built before 1964 has the highest energy demand of all dwellings in the Dutch dwelling stock. This dwelling typically consists of non-insulated cavity walls, a non-insulated wooden roof and a non-insulated floor. The general characteristics of the detached dwelling are listed in Table 2 and the dwelling is visualized in Fig. 3. Examples of the dwelling are shown in Fig. 4.

Table 2. General characteristics of the detached dwelling.

General characteristics		
Usable floor area ²	130	m ²
Number of inhabitants	3.0	
Energy consumption	18,371	kWh/a
Building components	Surface (m ²)	U value (W/m ² K)
Ground floor	93.0	1.72
Inclined roof	128.1	1.54
Opaque facades	136.7	1.61
Single glazing ³	8.0	5.20
Double glazing	20.3	2.90
Technical specifications		
Orientation front façade	Azimuth 90° (east)	
Roof angle	56°	

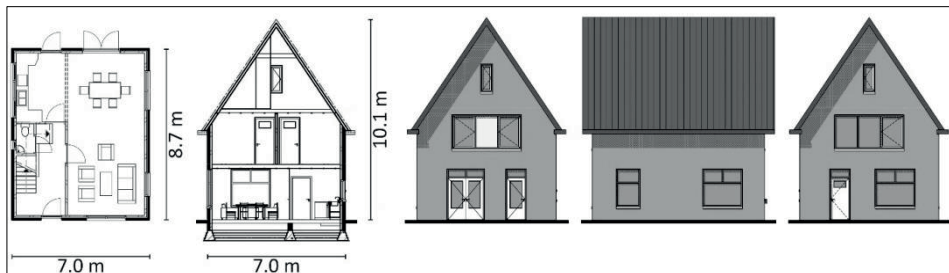

Figure 3. Detached dwelling: floor plan, cross section and facades (back, side, and front).



Figure 4. Images of typical Dutch detached dwellings from the period before 1964 [37].

² Fully enclosed space that is available for the use of a building user.

³ In this dwelling type both single and double glazing is present.

2.1.2 Terraced dwellings

Terraced dwellings from the building period 1946-1964 were rapidly built during the reconstruction after World War II in a period where there were no rules or regulations concerning energy performance. Due to a high level of repetition and the technical characteristics of this category, sustainable renovation is widely investigated in the Netherlands [51]. Many of these dwellings were equipped with gas heating devices in each room, electrical boilers for warm tap water, natural ventilation and steel / wooden window frames. The general characteristics of the terraced dwelling are listed in Table 3 and the dwelling is visualized in Fig. 5. Examples of the dwelling are shown in Fig. 6.

Table 3. General characteristics of the terraced dwelling.

General characteristics		
Usable floor area ⁴	87	m ²
Number of inhabitants	2.8	
Energy consumption	9,201	kWh/a
Building components	Surface (m ²)	U value (W/m ² K)
Ground floor	47.0	1.72
Inclined roof	57.3	1.54
Opaque facades	42.3	1.61
Single glazing ⁵	6.5	5.20
Double glazing	14.9	2.90
Wall between dwellings	53.0	1.61
Technical specifications		
Orientation front façade	Azimuth 180° (south)	
Roof angle	25°	

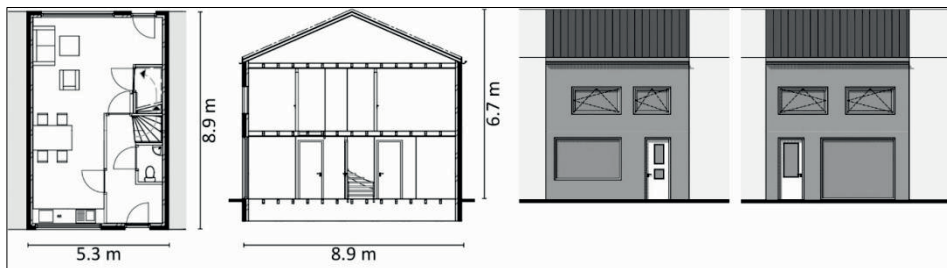

Figure 5. Terraced dwelling: floor plan, cross section and facades (front, back).

⁴ Fully enclosed space that is available for the use of a building user.

⁵ In this dwelling type both single and double glazing is present.



Figure 6. Images of typical Dutch terraced dwellings from the period 1964-1964 [37].

2.2 Renovation scenarios

The dwellings have both been redesigned with 4 successive *ZEB* scenarios, indicated in Fig. 7. The renovation scenarios are based on a theoretical framework of applicable add-on packages and do not represent the actual Dutch energy efficient renovation strategies. Materials selected for the insulation packages are fully based on renewable sources, to minimize material related environmental impact.

The impact of the following 4 scenarios is calculated, which are further described in the following paragraph and the applied materials are indicated in Table 4:

- A. current situation with no added insulation and supplied with 100% Renewable Energy (RE) by PV;
- B. current situation with insulation by filling air cavities in the floor, roof and wall and 100% RE for remaining demand by PV;
- C. add-on insulation package and 100% RE for remaining demand by PV;
- D. add-on insulation package with a load-bearing additional wall structure and 100% RE for remaining demand by PV.

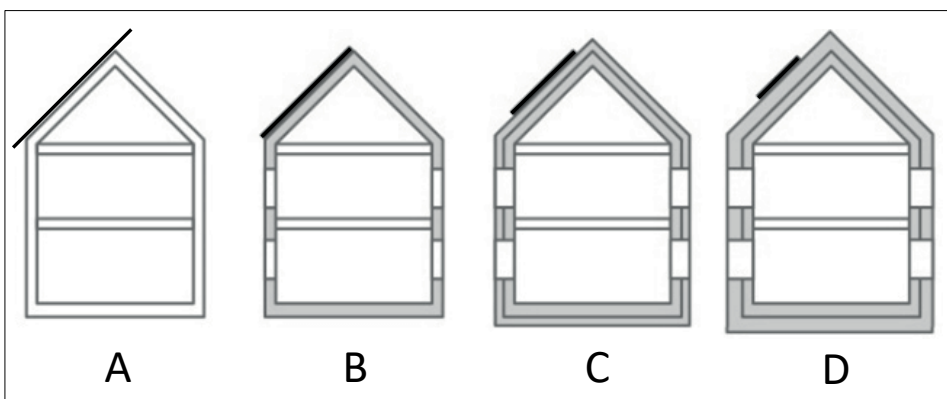

Figure 7. Concept of adding insulation packages (grey) and PV modules (black) to the outside of the building envelope to transform existing dwellings into *ZEBs*.

2.2.1 *Current situation – Scenario A*

In the current situation, no insulation package has been added, as indicated in Fig. 8. The operational energy demand is completely generated by PV modules integrated in the roof. The average U values of the building envelope components are indicated in Table 4 and the applied materials are indicated in Table 5.

2.2.2 *Scenario B*

Insulation package B consists of insulating the existing building envelope, as indicated in Fig. 8. The air cavities in the cavity walls are filled with 40 mm wood fiber insulation. The cavities between the ground floor girders and the roof girders are filled with 160 mm wood fiber insulation and the roof is finished with 18 mm fiberboard on the inside. The existing glass is replaced by high insulation double pane glazing. The operational energy demand is completely generated by PV modules integrated in the roof. The average U values of the building envelope components are indicated in Table 4 and the applied materials are indicated in Table 5.

2.2.3 *Scenario C*

Insulation package C consists of an add-on to the insulated building envelope with package B, as indicated in Fig. 8. On the outside of the facades, 100 mm wood fiber insulation is added, finished with plaster. The roof tiles are removed in order to place 52 mm of wood fiber insulation and new battens, before the original and additional needed roofing tiles are replaced. Additionally, 160 mm of wood fiber insulation is placed underneath the ground floor, finished with 18 mm multiplex. The existing glass is replaced by high insulation double pane glazing and larch window frames replace the existing window frames. The operational energy demand is completely generated by PV modules integrated in the roof. The average U values of the building envelope components are indicated in Table 4 and the applied materials are indicated in Table 5.

2.2.4 *Scenario D*

Insulation package D consists of a wooden load bearing structure of 140 mm girders filled with 140 mm of wood fiber insulation on both the facades and the roof, in combination with the already added insulation packages B and C, as indicated in Fig. 8. An additional 52 mm wood fiber insulation is placed underneath the ground floor. The existing glass is replaced by high insulation triple pane glazing and insulated larch window frames replace the window frames. The operational energy demand is completely generated by PV modules integrated in the roof. The average U values of the building envelope components are indicated in Table 4 and the applied materials are indicated in Table 5.

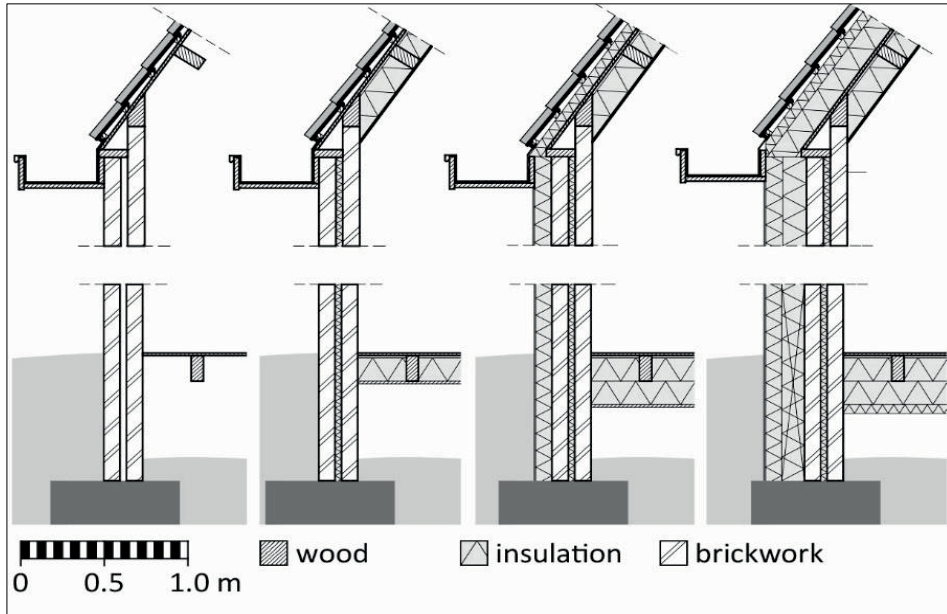

Figure 8. FLTR: vertical sections of the outer cavity wall in the current situation A, insulation package B, insulation package C, and insulation package D.

Table 4. Achieved average U values (W/m^2K) of the building envelope components in the different scenarios.

Component	Scenario			
	Current state A	Insulation package B	Insulation package C	Insulation package D
Facade	2.6	0.83	0.29	0.15
Ground floor	4.4	0.25	0.13	0.09
Roof	4.2	0.25	0.14	0.10
Glazing	5.72 (single pane) / 1.3 2.77 (double pane)		1.1	0.7
Window frames	2.4	2.4	1.4	0.78

Table 5. Applied materials in the different scenarios with their key indicators for this evaluation.

Scenario	Material	Density	U value (W/m ² K)	Embodied energy (EE)	Embodied land direct ^B	Circular embodied land and EE embodied land ^B
all	PV modules	14.3 kg/m ^{2C}	n.a.	4060 MJ/m ^{2C}	4.97 m ^{2a}	4299.9 m ^{2a}
B	160 mm wood fiber ground floor insulation	190 kg/m ^{3A}	0.24	17 MJ/kg ^A	0.47 kg/m ^{2a}	0 kg/m ^{2a}
B	40 mm wood fiber cavity wall insulation	55 kg/m ^{3A}	1.00	17 MJ/kg ^A	0.47 kg/m ^{2a}	0 kg/m ^{2a}
B	160 mm wood fiber roof insulation	55 kg/m ^{3A}	0.28	17 MJ/kg ^A	0.47 kg/m ^{2a}	0 kg/m ^{2a}
B	18 mm multiplex boarding roof	650 kg/m ^{3A}	0.09	15 MJ/kg ^A	0.47 kg/m ^{2a}	0 kg/m ^{2a}
B	HR++ double pane glazing	2600 kg/m ^{3C}	1.1	15 MJ/kg ^C	0.10 kg/m ^{2a}	0 kg/m ^{2a}
C	100 mm wood fiber exterior wall insulation	190 kg/m ^{3A}	0.44	17 MJ/kg ^A	0.47 kg/m ^{2a}	0 kg/m ^{2a}
C	'Forel clay' lime plasterwork	1300 kg/m ^{3C}	0.02	3 MJ/kg ^C	0.00 kg/m ^{2a}	0.53 kg/m ^{2a}
C	52 mm wood fiber roofing insulation	250 kg/m ^{3A}	0.32	17 MJ/kg ^A	0.47 kg/m ^{2a}	0 kg/m ^{2a}
C	Additional row ceramic roof tiles	2000 kg/m ^{3C}	n.a.	6.5 MJ/kg ^C	0.00 kg/m ^{2a}	0.53 kg/m ^{2a}
C	Battens / counter battens	460 kg/m ^{3C}	n.a.	7.4 MJ/kg ^C	0.47 kg/m ^{2a}	0 kg/m ^{2a}
C	Larch window frame	590 kg/m ^{3C}	1.4	7.4 MJ/kg ^C	0.47 kg/m ^{2a}	0 kg/m ^{2a}
D	140 mm wood fiber exterior wall insulation	55 kg/m ^{3A}	0.27	17 MJ/kg ^A	0.47 kg/m ^{2a}	0 kg/m ^{2a}
D	Spruce wooden construction 140 mm exterior wall	460 kg/m ^{3C}	1.22	7.4 MJ/kg ^C	0.47 kg/m ^{2a}	0 kg/m ^{2a}
D	140 mm wood fiber roof insulation	55 kg/m ^{3A}	0.32	17 MJ/kg ^A	0.47 kg/m ^{2a}	0 kg/m ^{2a}
D	Spruce wooden construction 140 mm roof	460 kg/m ^{3C}	0.27	7.4 MJ/kg ^C	0.47 kg/m ^{2a}	0 kg/m ^{2a}
D	HR++ + triple pane glazing	2600 kg/m ^{3C}	0.7	15 MJ/kg ^C	0.10 kg/m ^{2a}	0 kg/m ^{2a}
D	Cork window insulation	550 kg/m ^{3C}	0.78	4 MJ/kg ^C	0.02 kg/m ^{2a}	0 kg/m ^{2a}

^A product information producer [46]^B MAXergy report [42]^C ICE database [44]

For a comparable environmental impact assessment of the different renovation scenarios of both dwelling types in this research, the following conditions and characteristics have been defined:

General conditions:

- Geographic location: Maastricht, the Netherlands (50° 51' 0" latitude, 5° 41' 0" longitude and 50 m altitude). Maastricht has a moderate sea climate (type Cfb according to the Köppen Climate Classification [52]) with relatively mild summers (17.5°C), mild winters (3.1°C) and annually 773 mm of precipitation [53]. The average annual temperature in Heerlen is 9.9 °C [53]. The annual direct solar irradiation is 1069 kWh/m² [45] and the location has 1480 solar hours yearly [53].
- Only the environmental impact of the added materials has been taken account, neglecting the current materials embodied in the dwelling types.
- The lifespan of the scenarios is 50 years.

Insulation characteristics:

- The insulation materials applied are fully based on renewable resources, such as wood, which might not be applicable in real-life circumstances.
- The impact of internal condensation and heat/cold bridges is neglected;
- The impact of small-scale construction materials such as nails and screws is neglected;
- Air permeability of 1 dm³/s·m² at pressure difference of 10 Pa (qv10);
- The crawl space has 0.4 m height and allows insulation of the floor of the heated spaces above.

Installation characteristics:

- The operational energy generation is based on all electric PV (240 Wp⁶/module, building integrated);
- The lifespan of the PV modules is 25 years;
- Heating by ground heat pump with a COP of the heat pump boiler 2.2 for warm tap water and a COP of the heat pump 4.3 for room heating;
- Heating by low temperature fluid floor heating (35-45 °C);
- Mechanical ventilation with natural entry, without heat recovery;
- The impact of materials in the heating and ventilation installation is neglected.

⁶ Wp indicates the nominal power of a PV module.

3. Results

3.1 Energy performance

The effect of the insulation packages on the primary energy consumption (PEC) and is calculated using BINK software [43]. The output of the PV modules has been calculated in PVGIS, resulting in 129 kWh/m²a in the detached dwelling case and 134 kWh/m²a in the terraced dwelling case due to the different inclination of the roof [45]. The primary energy values provided by BINK software are used to calculate the final energy consumption (FEC), which is the actual energy provided to the end-user after conversion and transportation losses [54]. In the Netherlands, the current average electricity conversion yield for coal power plants is 40% and the conversion factor from kWh to MJ is 3.6 [3]. The main results covering the energy performance are indicated in Table 6.

Table 6. Operational energy (OE) and amount of PV modules (m²) of the different scenarios in the two dwelling types.

	Average U- value of the building envelope (W/m ² K)	OE PEC (MJ/a)	OE FEC (MJ/a)	OE FEC (kWh/a)	OE heating demand PEC (MJ/a)	OE heating demand FEC (MJ/a)	Surface of PV modules to generate OE FEC (m ²)
Terraced dwelling							
Scenario A	2.78	82,811	33,124	9,201	64,151	25,660	68.8
Scenario B	0.29	42,134	16,854	4,682	27,695	11,078	35.0
Scenario C	0.17	38,682	15,473	4,298	24,258	9,703	32.1
Scenario D	0.12	36,950	14,780	4,106	22,541	9,016	30.7
Detached dwelling							
Scenario A	3.03	165,341	66,136	18,371	142,301	56,920	142.0
Scenario B	0.29	86,773	34,709	9,641	65,154	26,062	74.5
Scenario C	0.17	75,738	30,295	8,415	53,940	21,576	65.1
Scenario D	0.12	63,316	25,326	7,035	40,342	16,137	54.4

As the available south facing roof surface of the terraced dwelling is 28.5 m² none of the scenarios would be practically feasible without higher efficiency modules and/or PV modules facing north. As the available south facing roof surface of the detached dwelling is 64.0 m², scenario A and B would not be practically feasible without higher efficiency modules and/or PV modules facing north.

3.2 Mass and embodied energy

The first step in calculating towards embodied energy and eventually towards embodied land is to calculate the mass of the insulation packages and the PV modules. The mass of insulation is based on the applied materials mentioned in Table 4 and Table 6 for the amount of PV modules. In the calculations the impact of the PV modules has been doubled in the project lifespan of 50 years because the PV modules have an expected lifespan of 25 years. The mass and embodied energy results for both dwelling types are shown in Table 7 and Fig. 9 and Fig. 10.

Table 7. Mass, embodied energy (EE) and PV surface needed for EE generation of the different scenarios in the two dwelling types over a lifespan of 50 years.

	Mass insulation (kg)	Mass PV modules (kg)	Mass total (kg)	EE insulation (MJ)	EE PV modules (MJ)	EE total (MJ)	Surface of PV modules to generate EE (m ²)
Terraced dwelling							
Scenario A		989	989		558,607	558,607	5.8
Scenario B	2,834	503	3,337	45,950	284,228	330,178	3.4
Scenario C	6,364	462	6,826	92,100	260,938	353,038	3.7
Scenario D	9,176	441	9,617	140,261	249,256	390,682	4.1
Detached dwelling							
Scenario A		2,041	2,041		1,153,041	1,153,041	12.4
Scenario B	4,586	1,071	5,657	74,034	605,130	679,164	7.3
Scenario C	12,141	935	13,076	166,489	528,175	694,664	7.5
Scenario D	16,566	782	17,348	236,887	441,543	680,391	7.3

To minimise building related environmental impact, a building should generate the embodied energy as well, resulting in a Life Cycle Zero Energy Building (LC-ZEB). A LC-ZEB is a building whose operational energy consumption and the embodied energy in materials and systems is compensated by the renewable energy production within the building itself, on a yearly base (based on [8, 55]). To fulfill the demand of LC-ZEB an additional 3.4 -12.4 m² of PV modules should be embedded in the redesign, as indicated in Table 7, which would affect the outcomes of the environmental impact calculations. In this study,

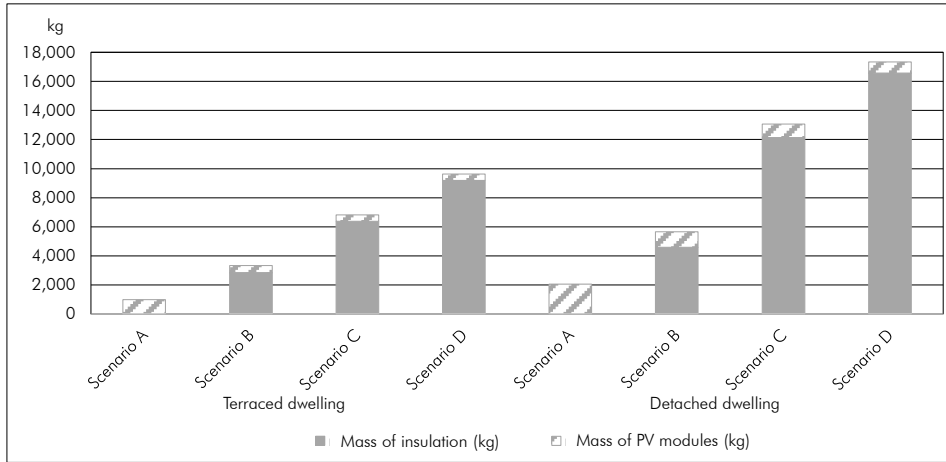

Figure 9. Mass (kg) of the different scenarios in the two dwelling types.

Considering mass, scenario A, consisting of only adding PV modules has the lowest result, as shown in table 7 and Fig. 9. The mass of the PV modules is relatively small compared to the mass of the insulation packages.

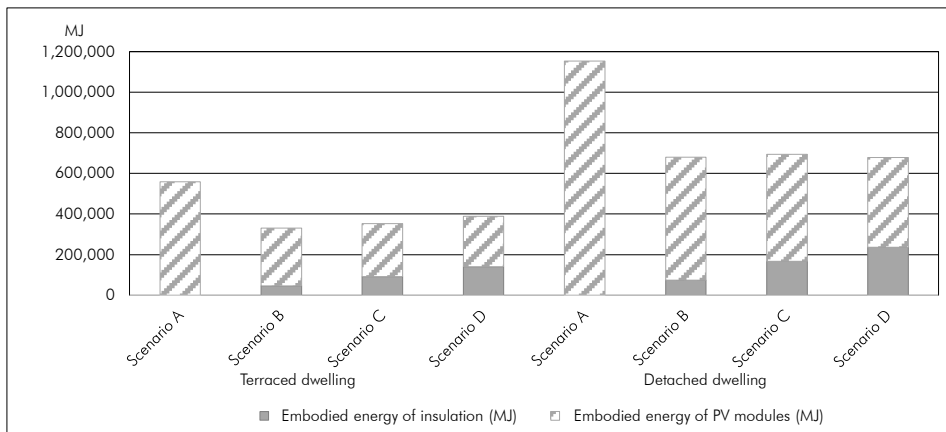

Figure 10. Embodied energy (MJ) of the different scenarios in the two dwelling types.

However, concerning embodied energy, the effect of the PV modules is significantly higher than the effect of the insulation package, due to the higher energy density of the PV modules compared to renewable insulation materials. Table 6 and Fig. 10 show that scenario B has the lowest embodied energy in both dwelling types, but that the differences between the scenarios in the detached dwelling are relatively small.

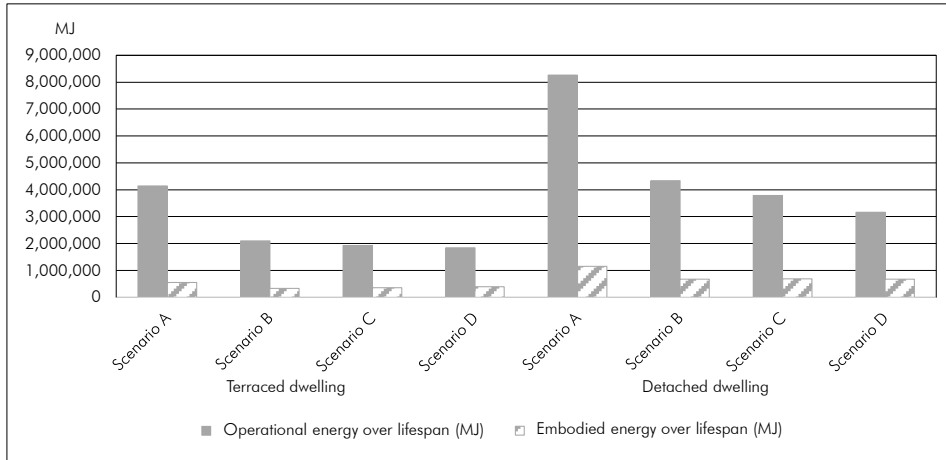

Figure 11. Embodied energy and operational energy (MJ) of the different scenarios in the two dwelling types with lifespan 50 years.

Considering embodied energy set against operational energy, as is shown in Fig. 11, with every successive scenario the sum decreases, and the embodied energy is relatively small compared to the operational energy.

3.3 Embodied land

Table 9 and Fig. 12 indicate the amount of embodied land in total, the land surface involved to generate the energy from solar radiation: the solar module surface (including extra land for conversion losses due to seasonal storage of electricity), and for processing the materials for the insulation options.

Table 9. Embodied land of the different scenarios in the two dwelling types.

	Embodied land PV modules (m ² ·a)	Embodied land insulation (m ² ·a)	Total Embodied Land (m ² ·a)
Terraced dwelling			
Scenario A	591,666	0	591,666
Scenario B	300,993	7,784	308,777
Scenario C	276,054	82,460	358,514
Scenario D	264,014	106,225	370,239
Detached dwelling			
Scenario A	1,221,172	0	1,221,172
Scenario B	640,685	12,959	653,644
Scenario C	559,847	226,018	785,865
Scenario D	467,829	264,860	732,689

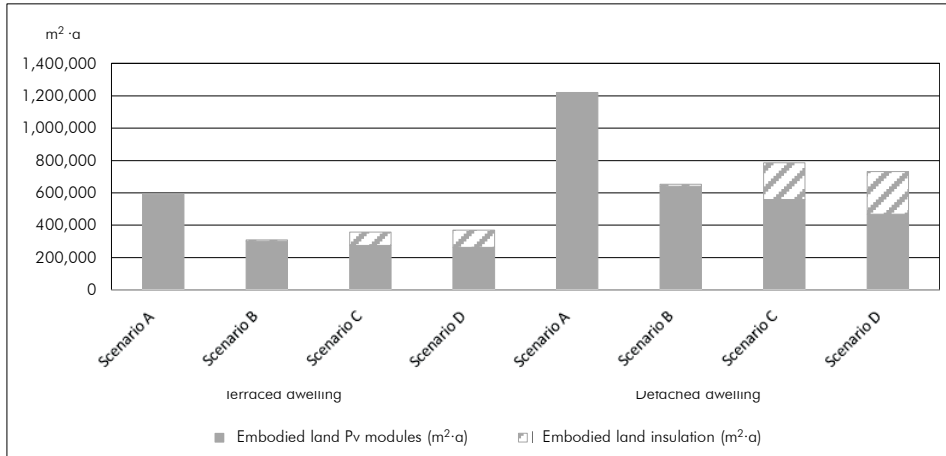

Figure 12. Embodied land (m²·a) of the different scenarios in the two dwelling types.

In both dwelling types, the scenario B correspond with the lowest amount of embodied land, indicating that the current strategy to renovate towards very high insulation values is from the point of carrying capacity not the solution with lowest environmental impact.

However, to relate the embodied land to the typical lifespan of a dwelling, Table 10 and Fig. 13 indicate the result for a 50 years lifetime. In this calculation, the PV modules are replaced after 25 years, increasing their impact.

Table 10. Embodied land of the different scenarios in the two dwelling types with lifespan 50 years.

	Embodied land PV modules (m ²)	Embodied land insulation (m ²)	Total embodied land (m ²)
Terraced dwelling			
Scenario A	11,833	0	11,833
Scenario B	6,020	156	6,176
Scenario C	5,521	1,649	7,170
Scenario D	5,280	2,125	7,405
Detached dwelling			
Scenario A	24,423	0	24,423
Scenario B	12,814	259	13,073
Scenario C	11,197	4,520	15,717
Scenario D	9,357	5,297	14,654

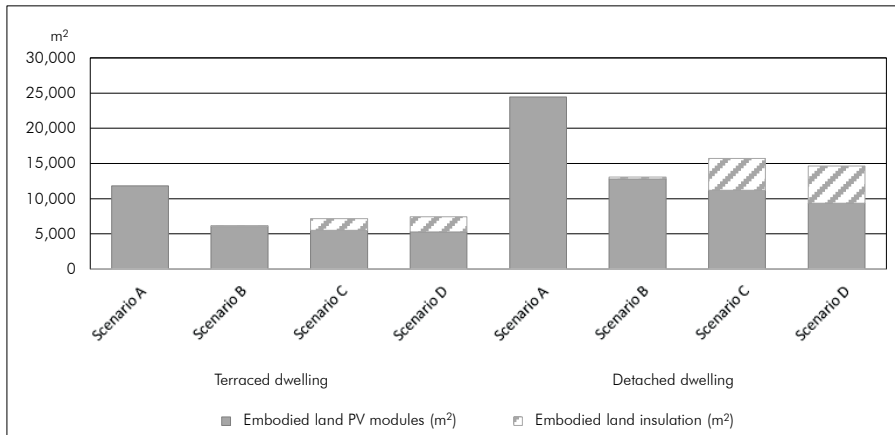

Figure 13. Embodied land (m²) of the different scenarios in the two dwelling types with lifespan 50 years.

Over a lifespan of 50 years, between 6,176 and 11,833 m² is needed to generate all the resources necessary for the ZEB renovation of the terraced dwelling type. Considering the detached dwelling type, between 24,423 and 13,073 m² is needed to reach the same level of energy performance.

In the calculations the land needed to generate the resources itself and to compensate for its use by re-growing the resources is included, applicable for the bio based insulation materials. To assess the impact of the use of non-renewable materials, minerals, and metals the ‘circular embodied land’ (Table 5) is introduced, the embodied land needed to restore concentrated material from dispersed resources, such as the clay, plaster and PV modules.

4. Discussion

In this study the environmental impact of different zero energy renovation scenarios for two Dutch dwelling types have been assessed, expressed in embodied energy and related to the carrying capacity, expressed in embodied land. In this theoretical exercise, different methods have been applied for the energy performance calculations and environmental impact calculations of insulation strategies based on renewable materials. However, in practice, occupant behaviour, construction traditions and technical possibilities will affect the outcomes.

Considering the energy aspect, even scenarios with high insulation levels result in an amount of PV modules exceeding the roof surface, emphasizing necessary improvements in the field of PV development.

Due to the scope of this research, other PV technologies, insulation materials and installation solutions might result in different optima. Moreover, social-economic aspects and maintenance have not been taken into account.

One of the main considerations regarding the carrying capacity based calculations is similar to the considerations regarding embodied energy and LCA calculations, namely the methodology, availability of data and uncertainty of calculated results due to differing input data. Considering the methodology, data from embodied energy databases is used and translated into time-land. This translation depends on numerous factors, such as solar radiation (inclination, orientation, and geographic location), soil type, etc. Considering the data used, this is often from other geographic location, depending on innovations (such as in the solar industry) and shows a large bandwidth (for instance on the field of embodied energy of solar modules). These factors lead to uncertainty of the calculated results. In future research, this has to be addressed more elaborately to provide clear guidance in the field of renovation the existing dwelling stock towards *LC-ZEB*.

Considering the carrying capacity of the Netherlands, 41,526 km² of territory is available. A total of 17,539 km² of the territory would be necessary to generate the materials and energy for the 2.84 million terraced dwellings and a total of 12,537 km² of the territory would be necessary to generate the materials and energy for the 959 thousand detached dwellings. 11,450 km² of the territory would remain for water, growing food, living and generating materials and energy for the other dwellings. This implicates that if the Netherlands has the ambition to realize a zero energy built environment based on its own carrying capacity, generating the necessary materials will conflict with other interests regarding land use.

5. Conclusions

Renovation of the existing dwelling stock is one of the key developments to decrease the, mainly fossil based, energy consumption and increase the level of renewable energy generation in the built environment. However, focusing on only energy in the operational phase does not cover the full scope to reach a sustainable built environment and both embodied energy and embodied land are useful indicators in a framework of complete impact assessment.

The lowest environmental impact is in both dwelling types created with an average building envelope U-value of 0.29 W/m²K in combination with 35 and 74.5 m² of PV modules for the terraced and detached dwelling type, respectively. To renovate the terraced dwelling type in this scenario to *ZEB* level, this would result in 3.8 GJ/m² embodied energy and 6,176 m² land would be necessary for a period of 50 years. To renovate the detached dwelling type in this scenario to *ZEB* level, this would result in 5.2 GJ/m² embodied energy and 13,073 m² land would be necessary for the same period.

Taking into account *LC-ZEB*, an additional 3.7-12.4 m² of PV modules should be added to the dwelling types to compensate for the energy embodied in materials.

This evaluation demonstrates the added value of a joint assessment of materials and energy in the building envelope to indicate the overall environmental impact. Moreover, indicating environmental impact in embodied land generates insight in the effect of the built environment related to the carrying capacity.

Acknowledgments

This research was partially funded by the Dutch Organization for Scientific Research (NWO), project number 023.001.198, by the Foundation Innovation Alliance (SIA), project number PRO-2-015 IMDEP and this project has received funding from the European Union's H2020 framework program for research and innovation under grant agreement no 633477 (MORE-CONNECT). The authors would like to thank all the partners in these projects for making this research possible.

References

1. IEA, *Key World Energy Statistics*. 2014, EIA.
2. USEIA, *International Energy Outlook 2011*. 2011, USEIA.
3. van Dril, A.W.N. and H.E. Elzenga, *Referentieramingen energie en emissies 2005-2020*. 2005, Energieonderzoek Centrum Nederland Milieu- en Natuurplanbureau Rijksinstituut voor Volksgezondheid en Milieu.
4. CBS, *Environmental accounts of the Netherlands 2011*. 2012, CBS.
5. European Commission, *Directive 2012/27/EU of the European Parliament and of the council on energy efficiency*. 2012.
6. European Commission, *Directive 2010/31/EU of the European Parliament and of the council on the energy performance of buildings (recast)*. 2010.
7. Boermans, T., M. Offermann, and R. de Vos, *A heating & cooling strategy for the European building sector until 2050*. 2015.
8. Hernandez, P. and P. Kenny, *Defining Zero Energy Buildings - A life cycle perspective*, in *PLEA 2008*. 2008.
9. Hernandez, P. and P. Kenny, *From net energy to zero energy buildings: Defining life cycle zero energy buildings (LC-ZEB)*. *Energy and Buildings*, 2010. 42(6): p. 815-821.
10. Peterson, K., P. Torcellini, and R. Grant, *A common definition for Zero Energy Buildings*. 2015, US Department of Energy.
11. Saheb, Y., et al., *Energy Renovation: The Trump Card for the New Start for Europe*. 2015, European Commission, Joint Research Centre, Institute for Energy and Transport.
12. Chynoweth, P. *The built environment interdiscipline: a theoretical model for decision makers in research and teaching*. *Structural Survey [conceptual paper] 2009* 2009 [cited 27 4]; 301-310].
13. Chesné, L., et al., *Energy saving and environmental resources potentials: Toward new methods of building design*. *Building and Environment*, 2012. 58: p. 199-207.
14. Cruz-Peragon, F., et al., *Characterization of solar flat plate collectors*. *Renewable and Sustainable Energy Reviews*, 2012. 16(3): p. 1709-1720.
15. CESBA, *Initiative Policy Paper - Towards a Common Sustainable Building Assessment in Europe*. 2014.
16. Bruckner, M., et al., *Materials embodied in international trade – Global material extraction and consumption between 1995 and 2005*. *Global Environmental Change*, 2012. 22(3): p. 568–576.
17. Leduc, W., et al. *expanding the exergy concept to the urban water cycle*. in *SASBE 2009*. 2009. Delft, the Netherlands.
18. Lugschitz, B., M. Bruckner, and S. Giljum, *Europe's global land demand - A study on the actual land embodied in European imports and exports of agricultural and forestry products*. 2011, Sustainable Europe Research Institute (SERI): Vienna, Austria.
19. van Dijk, S., M. Tenpierik, and A. van den Dobbels, *Continuing the building's cycles: A literature review and analysis of current systems theories in comparison with the theory of Cradle to Cradle*. *Resources, Conservation and Recycling*, 2014. 82: p. 21-34.
20. Bakx, M., et al., *A morphological design and evaluation model for the development of circular facades*, in *SB16*. 2016: Utrecht, the Netherlands.
21. Dixit, M.K., et al., *Need for an embodied energy measurement protocol for buildings: A review paper*. *Renewable and Sustainable Energy Reviews*, 2012. 16(6): p. 3730-3743.
22. Dixit, M.K., et al., *Identification of parameters for embodied energy measurement: A literature review*. *Energy and Buildings*, 2010. 42(8): p. 1238-1247.
23. Verbeeck, G. and H. Hens, *Life cycle inventory of buildings: A contribution analysis*. *Building and Environment*, 2010. 45(4): p. 964-967.
24. Thormark, C., *A low energy building in a life cycle—its embodied energy, energy need for operation and recycling potential*. *Building and Environment*, 2002. 37(4): p. 429-435.

25. Karimpour, M., et al., *Minimising the life cycle energy of buildings: Review and analysis*. Building and Environment, 2014. 73: p. 016-114.
26. Moncaster, A.M. and K.E. Symons, *A method and tool for 'cradle to grave' embodied carbon and energy impacts of UK buildings in compliance with the new TC350 standards*. Energy and Buildings, 2013. 66: p. 514-523.
27. Abanda, F.H., J.H.M. Tah, and F.K.T. Cheung, *Mathematical modeling of embodied energy, greenhouse gases, waste, Time-Cost parameters of building projects: A Review*. Building and Environment, 2013. 59: p. 23-37.
28. SER, *Energieakkoord voor duurzame groei*, 2013.
29. Gommans, L., *The use of material, space and energy from an exergetic perspective*, in SASBE. 2009: Delft.
30. Sartori, I. and A.G. Hestnes, *Energy use in the life cycle of conventional and low-energy buildings: A review article*. Energy and Buildings, 2007. 39(3): p. 249-257.
31. Tran, H.T. *measuring sustainability: carbon or land?* in iNTA-SEGA. 2009.
32. Rovers, R., et al. *designing for only energy: suboptimisation*. in PLEA 2011. 2011. Louvain-la-Neuve, Belgium.
33. Ritzen, M.G., Leo; Rovers, Ronald; Geurts, Chris; Vroon, Zeger; Sigwarth, Stefan. *Insulation versus installation - an exploration towards maximization*. in SB 13 Implementing sustainability - barriers and chances. 2013, Munich.
34. Balaras, C.A., et al., *European residential buildings and empirical assessment of the Hellenic building stock, energy consumption, emissions and potential energy savings*. Building and Environment, 2007. 42(3): p. 1298-1314.
35. CBS, *Veranderingen in de woningvoorraad; 1995-2011*. 2014 [cited 2016 11-3]; Available from: <http://statline.cbs.nl/StatWeb/publication/?DM=SLNL&PA=37263&D1=0-3,10,13&D2=0,11-13,128,317,608,689&D3=29,34,39,44,49,54,59,64,69,74,79,1&HDR=T&STB=G1,G2&VW=T>.
36. Loga, T., et al., *Use of Building Typologies for Energy Performance Assessment of National Building Stocks. Existent Experiences in European Countries and Common Approach*. 2010, Institut Wohnen und Umwelt GmbH: Darmstadt, Germany.
37. AgentschapNL, *Voorbeeldwoningen bestaande bouw*. 2011.
38. Tambach, M., E. Hasselaar, and L. Itard, *Assessment of current Dutch energy transition policy instruments for the existing housing stock*. Energy Policy, 2010. 38(2): p. 981-996.
39. Rovers, R., *Zero-Energy and Beyond: A Paradigm Shift in Assessment*. Buildings, 2014. 5(1): p. 1.
40. AgentschapNL, *Monitor energiebesparing gebouwde omgeving 2012*. 2013.
41. Rovers, R., *MAXergy and embodied land*. 2011, RiBuit / Zuyd University of Applied Sciences.
42. Rovers, V., et al., *Maxergy, duurzaamheidsberekening op basis van landgebruik*. 2011, RiBuit / Zuyd University of Applied Sciences.
43. BINK, *BINK Energy Performace Simulation Tool*. 2015 [cited 2015 1-5]; Available from: <http://www.binksoftware.nl/>.
44. Hammond, G. and C. Jones, *Inventory of Carbon & Energy (ICE)*. 2011, University of Bath, UK: Bath, UK.
45. European Commission Joint Research Centre (EC-JRC). *Photovoltaic Geographical Information System (PVGIS)*. 2015 [cited 2015 1-10].
46. *Pavatex product information*. 2015 [cited 2015 1-10]; Available from: <http://www.pavatex.nl/nl/home/>.
47. Rovers, R. *Urban harvest, and the hidden building resources*. in CIB World Building Conference. 2007.
48. Agudelo-Vera, C.M., et al., *Harvesting urban resources towards more resilient cities*. Resources, Conservation and Recycling, 2012. 64: p. 3-12.
49. Rovers, R., et al., *De Embodied Land indicator - Achtergrond en onderbouwing*. 2013, RiBuit / Zuyd University of Applied Sciences.
50. Ministry of transportation, public space and environment (VROM), *Kernpublicatie Woon Energie 2006*. 2009, VROM.

Chapter 4

51. Hoppe, T., *Adoption of innovative energy systems in social housing: Lessons from eight large-scale renovation projects in The Netherlands*. Energy Policy, 2012. 51: p. 791-801.
52. Kottek, M., et al., *World Map of the Köppen-Geiger climate classification updated*. Meteorologische Zeitschrift, 2006. 15(3): p. 259-263.
53. KNMI. *Maastricht, langjarig gemiddelden, tijdvak 1981-2010*. 2013; Available from: http://www.klimaatatlas.nl/tabel/stationsdata/klimtab_8110_380.pdf.
54. CBS, *Het energieverbruik voor warmte afgeleid uit de energiebalans*. 2010, CBS.
55. Sesana, M.M. and G. Salvalai, *Overview on life cycle methodologies and economic feasibility for nZEBs*. Building and Environment, 2013. 67: p. 211-216.

Chapter 5

Building Integrated Photovoltaics

This chapter was published as:
Ritzen, M.J., Vroon, Z.A.E.P. & Geurts, C.P.W.: *Building Integrated Photovoltaics*.
Photovoltaic Solar Energy: From Fundamentals to Applications, A. Reinders, P. Ver-
linden, W. van Sark & A. Freundlich (Eds.), pp. 579-590, Wiley, London, 2017

1. Introduction

Photovoltaic (PV) installations can be realized in different situations and on different scales, such as at a building level. The application of PV installations at a building level fits in the international tendency to realize energy efficient and zero energy buildings (ZEB) [1]. Application of PV installations on a building level has the following advantages, compared to other energy systems and other applications of PV installations:

- A PV installation can be easily applied to buildings, because it is relatively easily connected to the electrical system of a building;
- A PV installation is not based on either dangerous processes or use of dangerous resources;
- A PV installation does not consist of moving parts that need maintenance (except for sun trackers);
- A PV installation applied to buildings does not demand additional land for energy generation;
- Transmission losses are generally lower than with centralized energy generation because at least part of the generated energy is consumed at the same location;
- A PV installation on buildings is less vulnerable for theft and damage.

PV installations at a building level can either be added to the building envelope, which is called Building Added PV (BAPV) (Figure 1, left), or they can be integrated in the building envelope, named Building Integrated PV (BIPV) (Figure 1, right). In general we speak of a BIPV system if the installation is technically and aesthetically integrated, contributing to a homogeneous coverage of the building surface [2]. PV installations can either be applied in a grid-connected situation (see Section 11.1), autarkic with storage on-site or autarkic with direct consumption.



Figure 1. Free standing and roof mounted Building Added PV in Rotterdam, the Netherlands, 2013 (left) vs Building Integrated PV in Heerlen, the Netherlands, 2013 (right).

BIPV is seen as a necessary step in coping with our energy challenge in the next decades by realizing energy generation with societal accepted solutions. In general, it is assumed that by realizing BIPV the rise of a Not on My Roof (NoMyR) opposition by people can be prevented, which is based on the believe that PV is necessary but

should be realized further away, comparable with the Not In My BackYard (NIMBY) opposition against wind turbines. With a share of 1-3% BIPV has a relatively small market share compared to BAPV in the total PV market in 2012 [3].

In this chapter we will cover BIPV mainly from a holistic building viewpoint, covering the building design aspects of BIPV, the main regulatory and building codes issues related to the application of PV in the built environment, and conclude with the barriers ahead for large-scale deployment of BIPV.

2. BAPV vs BIPV

The definition of BIPV is still being discussed internationally. However, the main indicators of a BIPV system that are widely accepted are the following [4-6]:

- BIPV generates electricity;
- BIPV possibly replaces conventional building envelope materials;
- BIPV is aesthetically integrated in the building envelope:
 - o The PV components fit in the aesthetic design grid, or the design grid is based on PV components;
 - o Harmony of PV components in the design composition;
 - o PV component colour fits in the design;
 - o The PV technology fits in the design or the design is based on PV technology.

BIPV is seen as one of the four tracks to realize large scale PV deployment, besides higher PV efficiency, lower market price and storage network [7]. The possibilities and acceptance of BIPV depend on the local energy situation, scale of the project, local culture, type of financing [8], regulations and governmental incentives and should be integral part of the building design to accomplish a successful result.

The main advantage of BIPV compared to BAPV is that it contributes to an aesthetic more acceptable result. Secondary benefits are the possible material savings, financial savings and a contribution to the environmental consciousness impression of the building owner or occupant (Figure 2).



Figure 2. Two examples of BIPV on office buildings, contributing to the environmental consciousness impression of the occupants (left: office building in Barcelona, Spain, 2014, right: office building in Westerlo, Belgium, 2011).

The main disadvantage of BIPV compared to BAPV is that the integration may influence the building physics of the building envelope, increasing the risk of higher operating temperatures and higher levels of relative humidity [9], affecting the efficiency of the installation and possibly the lifespan of the installation.

The power output and efficiency of a PV installation depends linearly on the operating temperature [10]. The efficiency of PV crystalline silicon cells decreases by approximately 0.5% per °C temperature rise [11, 12]. The operating temperature of a PV module is influenced by the ambient temperature, the thermal properties of the module, the thermal properties of the installation and the insolation [13].

Higher operating temperatures can be found in BIPV due to a decreased and/or sealed air gap between PV systems and underlying envelope layer. This can particularly become problematic for fully building integrated PV [14]. Norton et al (2011) indicate that temperature rises in BIPV result in performance ratio losses between 2.2% and 17.0%. Higher operating temperatures can be prevented with cooling of PV systems, based on either air, fluids or Phase Change Materials (PCMs) [15].

Passive back-string ventilation cooling is seen as one of the most effective and easily applicable methods to cool PV systems [13, 14, 16-24]. The effect of back-string ventilation cooling depends on factors such as project scale, location, orientation, and inclination and should be an integral part of the BIPV design and realization process.

3. BIPV design

In future, the integration of PV modules in the building envelope should be seen as part of a new architectural era. BIPV products and components should not be positioned in the process as merely energy generating devices but should be seen as a building material as well, providing the optimal solution between aesthetic considerations and economic considerations. Current economic considerations are mainly related to energy generation, and energy has only economic value when needed.





There are many examples of physical integration of PV in the building envelope that lack an aesthetic integration [8], negatively effecting acceptance of BIPV as sustainable solution for our energy demand (Figure 3).

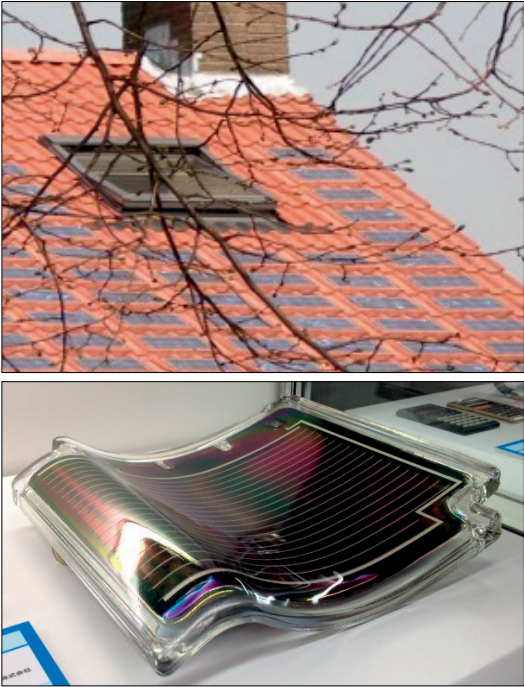





Figure 3. Two examples of BIPV systems in France (2013) in which the modules are from a technical point of view integrated in the building skin, but the aesthetic integration is lacking.

To select the best BIPV solution from the wide range of BIPV products for a specific building project, a collaborative system approach should be followed in which different experts cooperate closely, such as architects, installers and project manager. During the design and building process different aspects have to be taken into account, such as the architectural design, the location, thermal properties, building typology and function, building installations, user behavior, grid connection / energy storage, passive measures, etc. Within the scope of the definition of BIPV a very wide range of products can be applied.

Currently there are more than 100 different BIPV products developed with different techniques [2, 25, 26]. On different websites and in different publications extensive overviews of different BIPV products and applications are presented [2, 27-31]. In general two categories of BIPV products exist, namely roof systems and façade systems, that have different sub categories, such as flat roof, etc., for which different techniques and solutions are suitable [29, 32], indicated and visualized in Table 1:

Category	Sub category	Technique	Example
Roof systems	Flat roof	Roofing material	
	Pitched roofs	Opaque modules	
		Colored cells / modules	
		Shingles	 <p data-bbox="619 1552 1070 1603">Reproduced with permission by the Department of Geosciences, University of Wisconsin-Madison.</p>

Category	Sub category	Technique	Example
Roof systems	Pitched roofs	Tiles	 <p>The top image shows a traditional pitched roof covered in red tiles, with a skylight integrated into the structure. The bottom image shows a modern, curved, metallic-looking tile with a grid pattern, likely a solar tile, resting on a surface.</p>
		Skylights / semitransparent modules	 <p>The top image shows a green roof with solar panels and skylights. The bottom image shows a wooden roof structure with skylights.</p>

Category	Sub category	Technique	Example
Façade systems		Opaque modules	 <p>Reproduced with permission by Oskomera.</p>
			 <p>Reproduced with permission by Brooks Scarpa Architects.</p>
		Semitransparent modules	

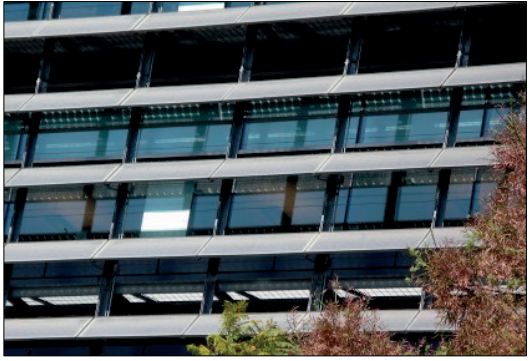
Category	Sub category	Technique	Example
		Shading devices	

To select the most appropriate BIPV product and develop a successful BIPV project, the following four aspects of integration have to be taken into account: building aesthetics, building quality, PV installation quality, and process quality [5, 6, 8, 20, 29, 33]. These four aspects with different levels and parameters are indicators of the level of 'BIPV-ness' of BIPV products and applications, and are described below:

1. The level of contribution to building aesthetics by the BIPV installation ranges from 0 to 4:
 0. The BIPV installation is not visible (e.g. rooftop);
 1. The BIPV installation is an added architectural element (e.g. shading devices);
 2. The BIPV installation contributes to the aesthetic quality (e.g. in facades / visible roofs);
 3. The BIPV installation determines the aesthetic quality (e.g. building design based on orientation, inclination and PV technology applied);
 4. The BIPV installation has resulted in a new architectural concept.
2. The contribution of the BIPV installation to the building quality can be described by the following features:
 - The BIPV installation is aesthetically integrated in the building envelope;
 - The BIPV installation is architecturally contributing to the building appearance;
 - The BIPV installation consists of colours, materials and composition that fit in and contribute to the building design;
 - The BIPV installation contributes to the quality of the urban tissue;
 - The BIPV installation contributes to an innovative design;
 - The building design prevents possible theft and damage of the BIPV installation;
 - In the site and building design shading (by trees, adjacent buildings, and other building components) is minimized complying with client's expectations.

3. The following technical aspects cover the BIPV installation quality:
 - The BIPV installation and its integration are well engineered, and the expected lifetime of BIPV component complies with client's expectations and building component it replaces;
 - The orientation and inclination of the BIPV installation is optimized within the building project's constraints;
 - The BIPV installation can be easily incorporated in the design and realization of the building envelope, displacing its costs;
 - All BIPV installation components (wiring, inverter placement, etc.) are an integral part of the system design and are easily reachable for maintenance, replacement, and cleaning;
 - The temperature increase in the BIPV installation is minimized within the design constraints.
4. The following aspects merely cover the quality of the embedding of the BIPV installation in the building process, related to environmental, societal, electrical and building related regulations:
 - The BIPV installation is integral part of the lifecycle cost of the building project and business case;
 - The BIPV installation complies with relevant electrical regulations and building codes;
 - The BIPV installation contributes to a lower overall environmental impact of the building project;
 - All actors in the BIPV project are supplied with sufficient information on the project;
 - The BIPV installation results in a minimal additional installation time.

4. BIPV building aspects, codes and regulations

BIPV products are more complex products than regular PV products and regular building envelope components because they are a combination of both. As indicated in the subsection 3, many technical solutions are possible and there are many aspects of integration to be taken into account. In the building process, architects and builders prefer modular elements [26], resulting in a selection of a 'standard' 60-cell module of 1 x 1.6 m. The lack of technical knowledge about sustainable buildings in general among architects is one of the main barriers in the current building process [34]. The level of integration of a standard PV module based installation depends on the mounting structure, which mainly consists of aluminium girders that are placed on the building structure instead of a regular cladding or roofing material. Fitting the dimensions of the modules in the dimensions of the complete building asks for knowledge and implementation of the product dimensions in the design process and

might result in dummies at the edges of roofs and facades. In the case of semi-transparent modules, these can be placed in the glazing frame.



Figure 25. Two examples of BIPV dummies, contributing to a homogenous building skin. (left: dummies in the top row of an experimental building in Heerlen, the Netherlands, 2014, right: dummies on the corners of an office building in Roelofarendsveen, the Netherlands, 2012, reproduced with permission by Luuk Kramer).

BIPV products have to comply with both existing and pending building codes and regulations and have to comply with the electricity generation regulations. These regulations differ in many cases from country to country, and from application to application [35], having a negative effect on BIPV product market introduction in different markets. In the French market this was partly compensated by an extra subsidy related to the level of BIPV-ness of the project [36, 37]. These rules are no longer in operation but application stay in and allow getting a Feed-in Tariff based subsidy.

As BIPV is relatively new on the market, suitable codes and regulations are not always developed and BIPV is in a 'grey' area of building legislation, which might cause complications and lengthy building permission procedures, resulting in potentially high administrative fees [38]. Weller et al (2010) have investigated the regulations to which different BIPV solutions have to comply, resulting in an overview of 7 regulations in Germany [35]. To facilitate the realization of BIPV in Germany, a document that combines the electrical technical and building regulations is being developed, the DIN VDE 0216-21. In the Netherlands and other countries that are on track to larger market penetration of BIPV, regulations are either recently developed or under development. In the Netherlands, a regulation, NEN 7250, specifies the application of solar energy systems (or complete building elements with PV) as an integrated component of the building envelope [39]. Considering Europe, the Construction Product Directive (CPD) is established in 1989 to facilitate the possibility of application of qualitative building components in the different countries. The CPD is based on 6 essential aspects; constructive safe and sound, fire proof, not harmful to man and animal, safe to use, low noise, and energy and cost efficient [36].

Aspects, such as fire regulation (fire tests are not yet included in BIPV EU standards) [35], solar access rights, regulatory instability [40], Product Category Rules

(PCRs) to develop Environmental Product Declarations, and BIPV centred financing schemes have not (fully) been taken into account. In a number of European countries demands and criteria for BIPV tests have been developed, focusing on wind loads, mechanical loads, snow loads, fire safety, condensation, temperature behaviour, and installation safety. These tests are being implemented by the European Institute for Normalization (CEN) in a European Regulation, but this can be a time-consuming process.

At the moment of writing, the situation for large-scale BIPV application is complex due to a combination of a large variety of BIPV products, the large scope of regulations the products have to comply with, the gap between technology and facilitating framework, the financial aspect, and the small market penetration. However, in the end, with or without building codes and regulations, the design, realization and functioning of the system have to result in a safe and sustainable functioning for 25 years [36].

5. Outlook

To reach a successful large-scale realization of BIPV projects, the building process has to be adapted to the implementation of BIPV. Tools such as a rating framework for BIPV-ness, 3-dimensional mapping and design of the built environment, an enabling framework of legislation and regulations, financing mechanisms and environmental assessment models have to be improved or developed to facilitate this adaption.

A larger market share of BIPV will contribute to a lower life cycle cost and contribute to the competitiveness of BIPV with other PV applications, other renewable energy sources, and regular building envelope components. In future, the large-scale application of the wide variety of BIPV products and applications will contribute to meeting our energy demand in a sustainable and societal accepted way.

References

1. European Commission, *Directive 2010/31/EU of the European Parliament and of the council on the energy performance of buildings (recast)*. 2010.
2. Sinapsis, K. and M.v.d. Donker, *BIPV Report 2013, State of the art in Building Integrated Photovoltaics*, SEAC, Editor. 2013, Solar Energy Application Centre: Eindhoven.
3. Clover, I. *BIPV sector to reach 1.15 GW by 2019, report says*. [website] 2014 4-22-2014 [cited 2014 11-6]; *BIPV market development numbers*. Available from: http://www.pv-magazine.com/news/details/beitrag/bipv-sector-to-reach-115-gw-by-2019--says-report_100014922/#ixzz3lHpBOXu8.
4. Voss, K., H. Laukamp, and M. Utheil, *Photovoltaic for buildings - market, technology, architecture, energy concepts*, F.I.f.S.E.S. ISE, Editor.
5. Kaan, H. and T. Reijenga, *photovoltaics in an architectural context. progress in photovoltaics: research and applications*, 2004. 12: p. 395-408.
6. Schoen, T., et al., *Status report of Task VII of the IEA program: PV in buildings*. *Renewable Energy*, 1998. 15(1-4): p. 251-256.
7. Raugei, M. and P. Frankl, *Life cycle impacts and costs of photovoltaic systems: Current state of the art and future outlooks*. *Energy*, 2009. 34(3): p. 392-399.
8. Reijenga, T., *PV in Architecture*, in *Handbook of Photovoltaic Science and Engineering*, A. Luque and S. Hegedus, Editors. 2005, John Wiley & Sons Ltd: Chichester, UK.
9. Ritzen, M., et al., *Comparative performance assessment of four BIPV roof solutions in the Netherlands*, in *ICBest 2014*. 2014: Aachen.
10. Dubey, S., J.N. Sarvaiya, and B. Seshadri, *Temperature Dependent Photovoltaic (PV) Efficiency and Its Effect on PV Production in the World – A Review*. *Energy Procedia*, 2013. 33(0): p. 311-321.
11. Hasan, A., et al., *Evaluation of phase change materials for thermal regulation enhancement of building integrated photovoltaics*. *Solar Energy*, 2010. 84(9): p. 1601-1612.
12. Quesada, G., et al., *A comprehensive review of solar facades. Opaque solar facades*. *Renewable and Sustainable Energy Reviews*, 2012. 16(5): p. 2820-2832.
13. Norton, B., et al., *Enhancing the performance of building integrated photovoltaics*. *Solar Energy*, 2011. 85(8): p. 1629-1664.
14. Mei, L., et al., *Equilibrium thermal characteristics of a building integrated photovoltaic tiled roof*. *Solar Energy*, 2009. 83(10): p. 1893-1901.
15. Hendricks, J.H.C. and W.G.J.H.M. van Sark, *Annual performance enhancement of building integrated photovoltaic modules by applying phase change materials*. *Progress in Photovoltaics: Research and Applications*, 2013. 21(4): p. 620-630.
16. Sadineni, S.B., S. Madala, and R.F. Boehm, *Passive building energy savings: A review of building envelope components*. *Renewable and Sustainable Energy Reviews*, 2011. 15(8): p. 3617-3631.
17. Bloem, J.J., et al., *An outdoor Test Reference Environment for double skin applications of Building Integrated PhotoVoltaic Systems*. *Energy and Buildings*, 2012. 50(0): p. 63-73.
18. Huang, M.J., *two phase change materials with different closed shape fins in building integrated photovoltaic system temperature regulation*. in *World Renewable Energy Congress 2011*. 2011. Linköping, Sweden.
19. Maturi, L., et al., *analysis and monitoring results of a BIPV system in northern Italy*. in *PVSEC*. 2010. Valencia, Spain.
20. Petter Jelle, B., C. Breivik, and H. Drolsum Røkenes, *Building integrated photovoltaic products: A state-of-the-art review and future research opportunities*. *Solar Energy Materials and Solar Cells*, 2012. 100(0): p. 69-96.
21. Tyagi, V.V., S.C. Kaushik, and S.K. Tyagi, *Advancement in solar photovoltaic/thermal (PV/T) hybrid collector technology*. *Renewable and Sustainable Energy Reviews*, 2012. 16(3): p. 1383-1398.
22. Gan, G., *Numerical determination of adequate air gaps for building-integrated photovoltaics*. *Solar Energy*, 2009. 83(8): p. 1253-1273.

23. Wang, Y., et al., *Influence of a building's integrated-photovoltaics on heating and cooling loads*. Applied Energy, 2006. 83(9): p. 989-1003.
24. Gan, G., *Effect of air gap on the performance of building-integrated photovoltaics*. Energy, 2009. 34(7): p. 913-921.
25. Jelle, B.P. and C. Breivik, *State-of-the-art Building Integrated Photovoltaics*. Energy Procedia, 2012. 20(0): p. 68-77.
26. Cerón, I., E. Caamaño-Martín, and F.J. Neila, '*State-of-the-art*' of building integrated photovoltaic products. Renewable Energy, 2013. 58(0): p. 127-133.
27. Verberne, G., et al. *BIPV Products for facades and roofs: a market analysis*. in PVSEC. 2014. Amsterdam, the Netherlands.
28. SUPSI/ISAAC., *BIPV - building integrated photovoltaics*. 2013 [cited 2015 3-3]. Available from: www.bipv.ch.
29. Memari, A.M., et al., *Building Integrated Photovoltaic Systems for Single Family Dwellings: innovation concepts*. Open Journal of Civil Engineering, 2014. 4: p. 102-119.
30. Svensson, O. and K.B. Wittchen, *PVNORD workpackage 3, task 1 report, Aesthetics of PV building integration*. 2004.
31. IEA_SHC_Task_41. *Innovative solar products for building integration*. 2014 [cited 2015 3-3]; Available from: <http://www.solarintegrationsolutions.org/>.
32. Eiffert, P. and G. Kiss, *Building-Integrated Photovoltaic Designs for Commercial and Institutional Structures*. 2000.
33. Bahaj, A.S., *Photovoltaic roofing: issues of design and integration into buildings*. Renewable Energy, 2003. 28(14): p. 2195-2204.
34. Attia, S. *Sizing photovoltaic systems during early design: a decision tool for architects*. in SB10. 2010. Maastricht, the Netherlands.
35. Weller, B., et al., *Photovoltaics, Technology, Architecture, Installation*. Detail Practice. 2010, Dresden: Birkhauser.
36. AgentschapNL, *Gebouwintegratie zonnestroomsystemen, Praktijkvoorbeelden van succesvolle producten*. 2011.
37. CEIAB, *Integration Rules for BIPV*. 2015 [cited 2015 3-3]; Available from: <http://www.ceiab-pv.fr/>.
38. Garbe, K., M. Latour, and P.M. Sonvilla, *PV legal final report - reduction of bureaucratic barriers for succesful PV deployment in Europe*. 2012.
39. NEN, *NEN 7250 - Solar energy systems - integration in roofs and facades - Building aspects*. 2014.
40. Barth, B., et al., *PV Grid Final Project Report*. 2014.

Chapter 6

Comparative performance assessment of a non-ventilated and ventilated BIPV rooftop configurations in the Netherlands

This chapter was published as:
Ritzen, M.J., Vroon, Z.A.E.P., Rovers, R. & Geurts, C.P.W.: *Comparative performance assessment of a non-ventilated and ventilated BIPV rooftop configurations in the Netherlands*. *Solar Energy*, vol. 146, pp. 389-400, 2017

Abstract

Backside ventilation is one of the most common passive cooling methods of PV modules in the built environment, but might be under constraint when integrating PV in the building envelope. To investigate the short and long term effect of backside ventilation on Building Integrated PV (BIPV) performance and lifespan, a comparative BIPV field test is conducted in a real life lab located in the Netherlands. The field test includes 24 modules in 4 segments with different levels of backside ventilation. PV energy output, module backside temperature, relative humidity in the air gap, and air velocity in the air gap have been monitored for three years in the period January 2013 – December 2015. At the end of the monitoring period Electric Luminescence (EL_v) images were made and Standard Testing Condition (STC) power was determined. The ventilated segments show a similar behaviour (6% difference) in PV energy output, but the non-ventilated segment shows a strong decrease of 86% in output after three years. A maximum temperature of 72°C is reached in the ventilated segments and a maximum temperature of 83°C in the non-ventilated segment. Relative humidity (RH) levels reach a maximum of 100% in all segments. Air velocity in the non-ventilated segment is 13-39% of the air velocity in the ventilated segments. STC power determination and EL_v imaging show lower peak power and more defects in the non-ventilated modules, and modules placed at vertical higher positions in the non-ventilated segment have a lower power output of 50-60%. The results indicate that, considering the first generation Metal Wrap Through (MWT) modules investigated, the non-ventilated BIPV modules exposed to the highest temperatures show the lowest power output, lowest STC power and show the most damaged cells in the EL_v imaging. Even though PV module manufacturing shows continuous technological advances, the methodology and results of this work has added value for the prediction of BIPV operating aspects and lifespan when designing and realizing a BIPV installation. Moreover, the BIPV field test presented in this study has been a very illustrative BIPV demonstration project for manufacturers, installers and designers.

1. Introduction

Between 1990 and 2005, global final energy consumption increased by 23%, while the associated CO₂ emissions increased by 25% [1]. This consumption is expected to grow by another 45% between 2002 and 2025 [2]. Of this global energy consumption, 20% to 40% is consumed in the built environment [3], of which more than 86% is based on fossil fuels [4]. Between 1995 and 2005, extraction of fossil fuels increased by 24% [5]. To lower overall energy consumption in the built environment and to lower dependency on fossil fuels, it has been agreed within the European Union (EU) that all new buildings in 2020 have to be (nearly) zero-energy buildings (nZEB) [3, 6]. nZEB implies that all building related operating energy is generated on the building site itself by renewable sources, calculated on a yearly basis [7, 8].

The building envelope plays a significant role in energy performance [9], as it influences the energy gains/losses through insulation values of opaque and transparent components and also provides the necessary space for the installation of active solar energy systems for energy generation [10].

One of the solutions to provide the necessary energy in the building itself is by applying active solar energy-generating devices in the form of photovoltaic (PV) modules for electricity. In a PV system solar radiation is converted into electricity, which can be used in the building itself, stored, or can be fed into the electricity grid. As the energy received from the sun on the earth's surface in one hour is equal to approximately one year's energy needs for mankind [11, 12], theoretically, it is possible to fulfil our energy needs completely using the sun, even with the current efficiency of PV systems, which ranges between 12% and 19%. Moreover, within the EU, approximately 70% of the electricity consumption could be generated by PV applied on buildings, based on the current PV efficiency [13, 14].

PV systems can be added to a building (Building Added PV - BAPV) or can be integrated in the building envelope (Building Integrated PV – BIPV), as illustrated in Fig. 1A and Fig1B. BIPV is part of the building design, possibly replacing conventional building materials such as wall cladding and /or roofing.

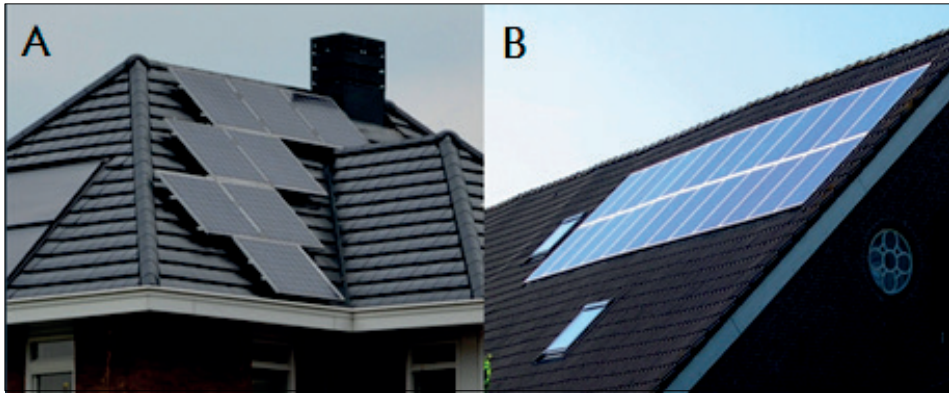

Figure 1. Examples of two projects with (A) Building Added PV (BAPV) and (B) Building Integrated PV (BIPV) in the Netherlands.

Integrating PV modules in the building envelope will lead to aesthetically and socially more acceptable solutions, contributing to large-scale realization of *nZEBs*. However, BIPV solutions generally result in a decrease of space between the PV installation and the thermal building envelope, negatively affecting the natural backside ventilation.

Backside ventilation is one of the methods to effectively cool PV systems [15-25], but this is under constraint when integrating PV in the building envelope. Decreasing the air gap height has a negative effect on PV performance because the efficiency of PV crystalline silicon cells drops by approximately 0.5% per °C temperature rise [26, 27]. Brinkworth et al. [28] showed in a theoretical study that minimum temperatures occurred with a roof-length-to-air-gap-width ratio of 20:1, whereas Gan et al. [21] showed in a theoretical study that the optimal air gap width for a 35° south-orientated 3-module system in the UK was 12.5 cm, with an air velocity of approximately 0.42 m/s.

Besides lower operational performance, higher temperatures of the PV modules might lead to a shortened lifespan and lack of ventilation might lead to condensation in the building structure. This can particularly become problematic in the case of completely integrated PV without any ventilation at all [25]. The Temperature Cycling Test 200 (TCT200) and Damp Heat Test (DHT) are the most critical tests for crystalline PV modules [29, 30]. Frequent changes in temperature in TCT200 are known to wear out the cell interconnections [29]. DHT indicates the quality of the lamination to protect the solar cells from humidity penetration. Humidity penetration causes corrosion [31], which causes cell malfunctioning. The DHT proved critical for 21% - 13% of tested crystalline PV modules in 2009 [29], and is perhaps the most critical for MWT modules [30]. Up to date, testing mostly takes place in lab facilities over smaller periods of time and degradation due to humidity penetration is not well known from operation in outside circumstance [32].

PV module manufacturers guarantee, in general, a maximum decrease of 20% of the STC power over 25 years of operation [33], up till a temperature of 85 °C, above which the warranty is voided [25]. However, research conducted in Switzerland show a decrease of 10 to 75% of the nominal power of the modules after a period of 12 years [33]. According to van Kampen, et al, temperature differences between BAPV and BIPV in Europe, based on a maximum ambient temperature of 40°C, can reach 30°C and can exceed the 85°C [34]. In the Netherlands a non-ventilated BIPV installation shows, on average, a 15°C higher temperature [35]. Other research efforts have shown temperature difference between BAPV and BIPV of 5°C in the Netherlands [36], and 20°C in Spain, with a lower efficiency of 7.3% [37].

The aim of this study is to investigate the short and long term effect of backside ventilation on BIPV performance of MWT modules.

Similar research and tests have been conducted on a smaller scale and shorter monitoring periods [21, 24, 25, 36, 38] and similar sized arrays have been monitored, but without varying backside ventilation levels [33, 39-42]. Moreover, combinations of Building Integrated PV (BIPV) with other functions in the building envelope have been studied, but without the variation of ventilation [10, 18, 43-48].

This paper is structured as follows. In section 2, the field test and the different methods used to simulate energy performance and measurements are presented. In section 3, the results are outlined and section 4 and 5 consist of the discussion and conclusion.

2. Methodology

In this study, a 5.6 kWp BIPV rooftop field test is realized in a real life lab in the Netherlands. The field test includes 4 PV segments with different levels of backside ventilation. Each segment includes 6 modules with first generation MWT cell modules. The field test has been equipped with sensors at the top and bottom of all segments in the air gap between the PV modules and the rooftop, monitoring PV module backside surface temperatures, air velocity, and relative humidity. Moreover, the installation has been equipped to measure the output of the PV segments and the output has been simulated with the System Advisory Model (SAM) [7]. To investigate the effect of ventilation on PV performance and lifespan, the BIPV field test has been monitored for 3 years, and at the end of the monitoring period Electric Luminescence (EL_v) imaging and STC power determination based on current-voltage (IV) testing of all modules has been conducted. Due to project limitations, EL_v imaging and STC power determination were not possible before realizing the field test. A comparison is made between the ventilated and non-ventilated segments covering simulated and measured energy performance, PV module backside temperature measurements, air velocity measured in the airgap, RH levels measured in the airgap, and end of

measurement evaluation of the modules in the BIPV installation. The design, realization and monitoring of the system accords with the international standard IEC 1829 (Crystalline silicon photovoltaic (PV) array – on-site measurement of IV characteristics) [49] and the international standard IEC 61724 (Photovoltaic system performance monitoring – guidelines for measurement, data exchange and analysis) [39].

2.1 Field test description

The experimental BIPV rooftop of the building “Bent to the Sun” in The District of Tomorrow (TDoT) has been developed as part of this study. TDoT is located on the European Science and Business Park Avantis in Heerlen/Aachen (on the border between the Netherlands and Germany). In TDoT four innovative and experimental buildings are being realized with increasing ambitions in the field of energy consumption and generation, material application and water consumption, including innovative BIPV solutions (indicated in Fig. 2 and Fig. 3.).

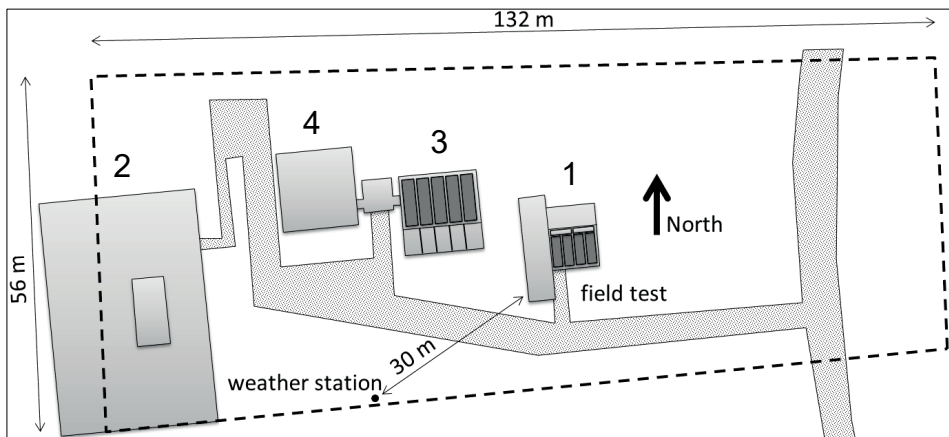

Figure 2. Plan of The District of Tomorrow (TDoT) with four innovative building objects and field test 1.



Figure 3. Picture of The District of Tomorrow (TDoT) with three realized innovative building objects, with at the right field test 1.

The location has a moderate sea climate (type Cfb according to the Köppen Climate Classification [50]), with relatively mild summers (17.5°C long term average), relatively mild winters (3.1°C long term average) and annually 773 mm of precipitation (long term average) [51]. The long term average annual temperature in Heerlen is 9.9 °C [51]. The long term average annual global horizontal irradiation is 1069 kWh/m² [52] and the location has a long term average of 1480 solar hours yearly [51]. The geographic location is 50°49'47.48" latitude, 6°1'2.06" longitude and 183 m altitude above mean sea level. The location is an open site without disturbance from building objects creating shadows on the field test. The highway between Heerlen (the Netherlands) and Aachen (Germany) is southwest of the location.

The field test includes 24 PV modules, which are placed in 4 segments of 6 modules each. Each segment has a different level of ventilation between rooftop and PV modules. Each module consists of 60 first generation MWT multi crystalline PV cells. MWT cells have an increased efficiency due to the electricity transport behind the cell with a conductive back sheet foil, reducing front side shadowing, in contrary to cells with the electricity transport on the front with bus bars [53, 54]. The lack of clearly visible bus bars possibly increases the aesthetical appearance (Fig. 4 and 5). The MWT modules consist of 4 mm ESG special front glass, EVA, and a composite film back side encapsulate [55], which is comparable to other mono and multi crystalline PV modules.

The difference in backside ventilation between the four segments was realized by installing the mechanical ventilation outlet behind two segments (Fig. 6, 7, 8, and 9), coupled to the building HVAC systems, with an average outlet air temperature of 17.2°C. One segment was left as-is with a natural ventilation duct of 13 cm (Fig. 10), whereas the theoretical optimum air gap for this inclination is approximately 12.5 cm [21], and the air gap behind one segment was sealed, as indicated in Fig. 6 and 8. Table 1 and 2 indicate the technical aspects of the BIPV field test.

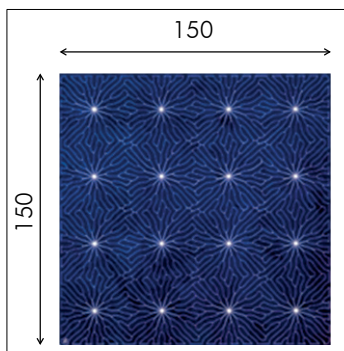

Figure 4. Metal Wrap Through (MWT) PV cell under investigation in this study (sizes in mm).



Figure 5. Photograph of the BIPV field test in of 4 portrait BIPV segments and 2 landscape solar thermal collectors at the top.

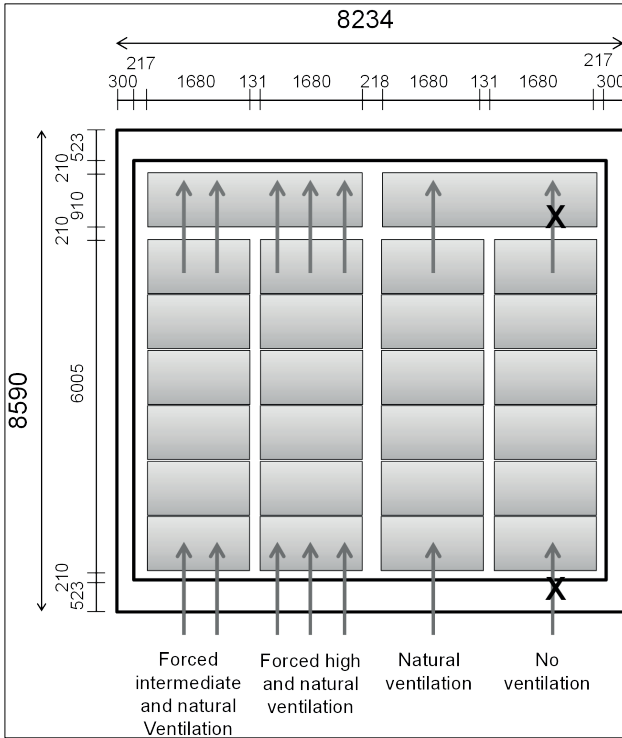

Figure 6. Rooftop overview of the four PV segments with different levels of backside ventilation in the PV field test in TDoT (sizes in mm). Two solar thermal collectors, indicated above the four PV segments, are not included in this research.

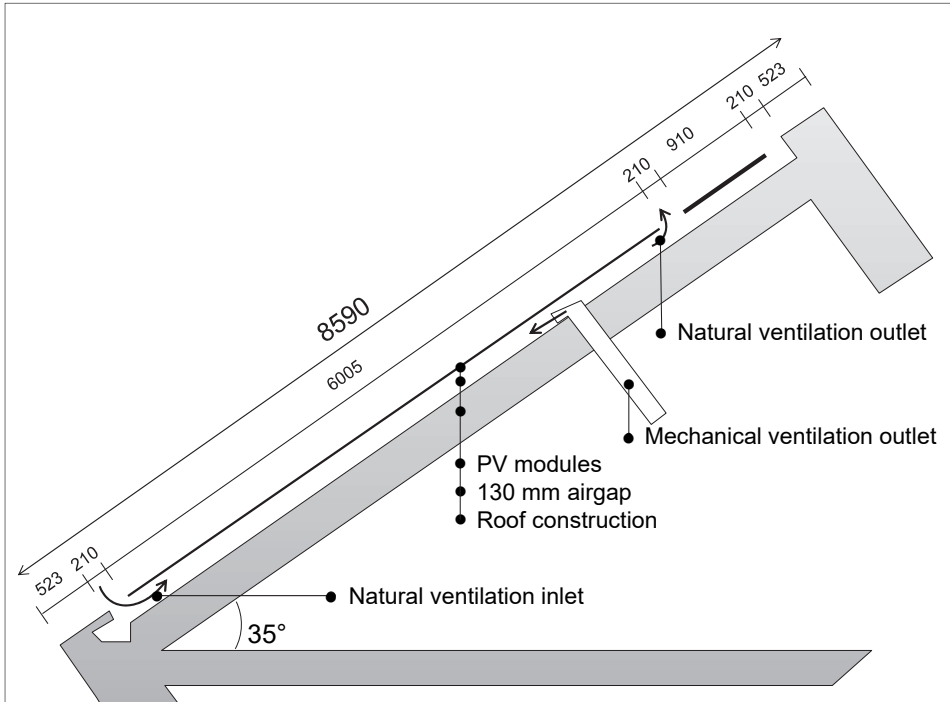

Figure 7. Vertical section of the field test with ventilation in- and outlets providing different levels of backside ventilation (sizes in mm).

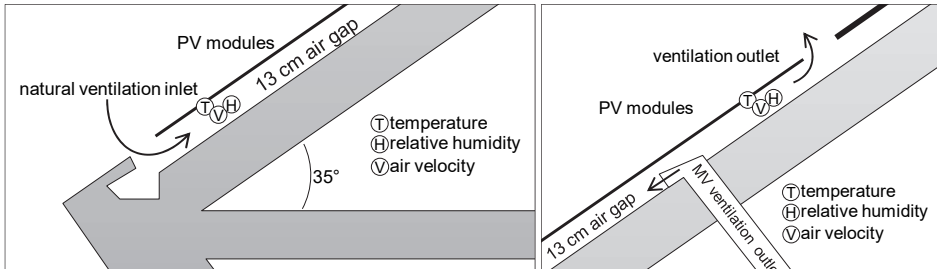

Figure 8 and 9. Vertical sections of the bottom and top of the PV segments 1 and 2 with the locations of the sensors used in this study, the realized air gap of 13 cm for backside ventilation, and the mechanical ventilation (MV) outlet.

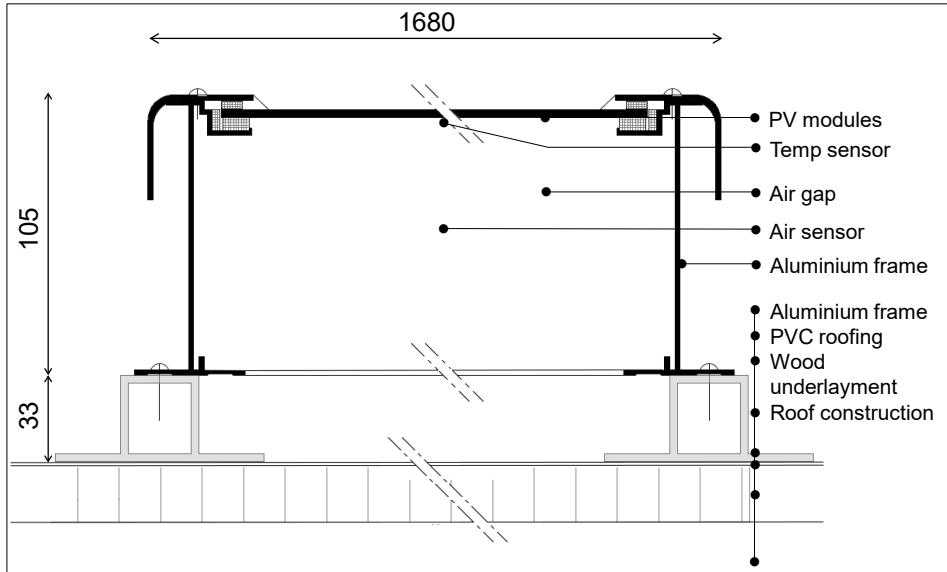

Figure 10. Technical horizontal section of the BIPV rooftop design. In the non-ventilated segment, the top and bottom opening has been sealed. All sizes in mm.

Table 1. Technical specifications of the PV module installation at STC⁷ used in SAM to calculate PV performance.

24 frameless glass-EVA-back sheet PV modules, area 1.59 m ²
4 vertical segments (6.0 x 1.68 m)
6 PV modules per segment
Multi-crystalline silicon MWT solar cells
60 cells in series per module
Direct power 234.99 Watt (Wdc) per module
Efficiency 14.78% per module
Nominal operating cell temperature 45°C per module
Maximum power point voltage (V _{mp}) 30.05 V per module
Maximum power point current (I _{mp}) 7.82 A per module
Open circuit voltage (V _{oc}) 36.97 V per module
Short circuit voltage (I _{sc}) 8.44 A per module
Temperature coefficient of V _{oc} -0.33%/°C per module
Temperature coefficient of I _{sc} 0.067%/°C per module
Temperature coefficient of maximum power point -0.43%/°C per module
Total installed power 5,640 Wdc

⁷ STC, standard test condition (cell temperature = 25°C; solar irradiance = 1 kW/m² and air mass = 1.5).

Table 2. Technical specifications per inverter used in SAM to calculate PV performance.

Maximum AC output power	1200 Wac
Manufacturer efficiency	90.0%
Maximum DC input power	1320.13 Wdc
Nominal AC voltage	240 Vac
Maximum DC voltage	400 Vdc
Maximum DC current	12.6 Adc
Minimum MPPT DC voltage	100 Vdc
Nominal DC voltage	120 Vdc
Maximum MPPT DC voltage	320 Vdc
Power consumption during operation	0 Wdc
Power consumption at night	0.1 Wac

2.2 Monitoring installation

The 5.6 kWp BIPV system was installed in September 2011 and began its operation in December 2012. The applied first generation MWT cells and PV modules were produced in 2010. In December 2012, all monitoring equipment was installed and was connected to a web-based data logging system in May 2013. The air-, surface-, and solar irradiance monitoring installation generate data output every 10 seconds, based on measurements every 1 second. The data is collected through a data logger, and sent to a FTP server, where the information is stored in .csv files. The energy performance monitoring installation generates data output with a 5-minute resolution based on measurements every 1 second. The programs MS Access, MS excel, and MAT lab were applied to generate insight into the data collection presented in this research. The performance of the installation is monitored continuously since May 2013.

The monitoring installation, indicated in Fig. 8, 9, 11 and 12, consists of the following:

- 8 PT100 4-wire surface temperature sensors, type Delta Ohm TP878.1SS, placed in the center on the back of the PV modules at the top and bottom of the segments (see Fig. 8, 9, and 11). Range + 4°C - + 85°C. Indicated by 'PTxx' in Fig. 11.
- 6 air-velocity and relative humidity sensors, type Delta Ohm HD29.371, placed in the air gap between the PV modules and the rooftop. Air-velocity range: 0.05 - 1 m/s, accuracy +/- 0.06 m/s + 2% of measurement at 50 % RH and 1013 hPa. Relative humidity range 5-98% RH, accuracy +/-2.5% (5-90%RH) - +/- 3.5% remaining range. Indicated by 'TVLxx' in Fig. 11.
- 2 relative humidity sensors, type Delta Ohm HD4817TC1.2, placed in the air gap between the PV modules and the rooftop. Relative humidity range 0-100%RH, accuracy +/-2% (10-90%RH), +/-2.5% outside. Indicated by 'TLxx' in Fig. 11.

- Horizontal solar irradiance is derived from a second class pyranometer (weather station type Delta Ohm HD52.3D 147R), thermopile, 0-2000 W/m² range, 1 W/m² resolution, installed at a height of approximately 191 m. above sea level, 16 m above local level, located approximately 30 m. west to south-west of the field test. (Fig. 2 and Fig. 3).
- Outside air temperature is derived from a PT100 (weather station type Delta Ohm HD52.3D 147R), range -40°C – 60°C, 0.1°C resolution, with an accuracy of +/-0.15°C +/- 0.1% of the measurement, installed at a height of approximately 191 m. above sea level, 16 m above local level, located approximately 30 m. west to south-west of the field test. (Fig. 2 and Fig. 3).
- The energy performance monitoring installation consists of 1 SMA sunnyboy 1200 inverter per segment, connected to a SMA sunny webbox. Generated data includes AC output (kWh) and DC and AC power (W). Note: The inverters affect the measurements and moreover, decreasing efficiency of the inverters might be of influence on the measurements [56].

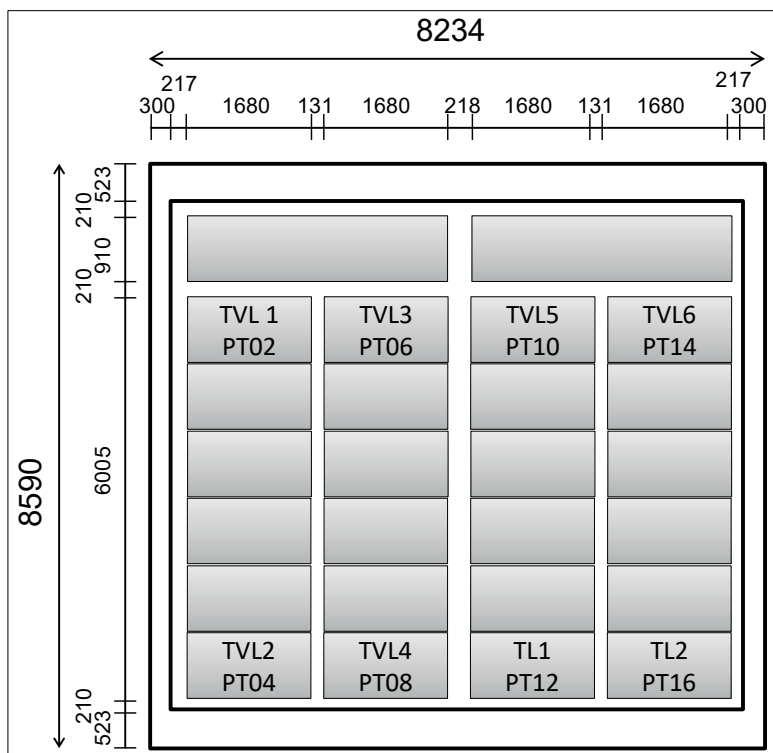

Figure 11. Overview of the monitoring sensors on the PV segments in the field test. Abbreviations of sensors: TVL= air temperature, air velocity and relative humidity, PT=surface temperature, TL= air temperature and relative humidity.

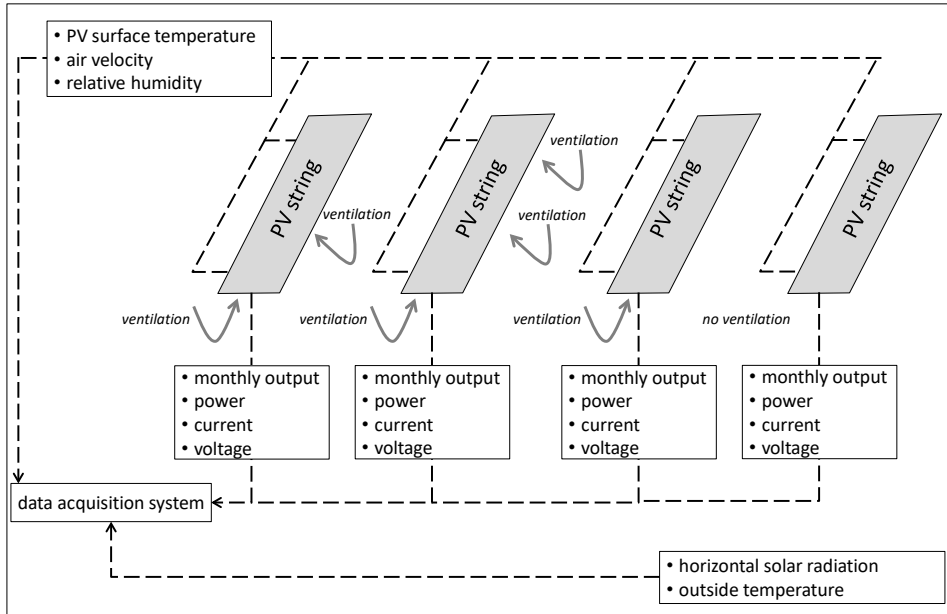

Figure 12. Overview of monitoring in the field test consisting of condition sensors on the PV installation, PV performance, and outside conditions.

2.3 Energy performance simulation

The energy performance of the BIPV installation was simulated with the System Advisor Model (SAM), developed by the United States National Renewable Energy Laboratory (NREL) [57]. SAM was used to make a performance prediction for the grid-connected installation. SAM offers the possibility to select the appropriate meteorological data for the location, the appropriate PV installation specifications and offers different integration levels affecting backside ventilation, and thus performance [58].

The difference in performance between the ventilated and non-ventilated BIPV has been calculated by:

$$\Delta_{perf} = \frac{E_{vent} - E_{non-vent}}{E_{vent}} \times 100 \quad (1)$$

2.4 End of measurement testing of the modules

After the three year monitoring period, the rooftop BIPV installation has been dismantled. All the modules have undergone a visual inspection before, during and after dismantling based on [29]. Due to weather circumstances with too low irradiance and clouding conditions, IR imaging did not result in useful results. A mobile lab has been used for Electric Luminescence (EL_v) imaging and STC power determi-

nation based on current-voltage (IV) testing at the end of the monitoring period on site. Due to project limitations, EL_v imaging and STC power determination on site before field test realization was not possible. EL_v imaging is a useful solar cell and module investigation method because it is fast, non-destructive and sensitive for non-visual defects [59, 60], but methods to analyze EL_v images are still to be fully developed. Consequently, a visual count of affected cells has been conducted. The specifications of the mobile lab are the following [61]:

Power measurement data:

- Flasher technology: long pulse LED flasher
- Luminous power: 850-1100 W/m²
- Light colour: warm white (2000-3000 K)
- Light spectrum: (400-800 nm)
- Local inhomogeneity: < +/-2%
- Lighting instability: < +/-2%
- Repeating accuracy: <0.5% deviation
- Deviation current/voltage measurement: current: < +/-0.1%; voltage < +/-0.1%
- Accuracy: 5%

Electroluminescence data:

- Camera: cooled NIR CCD cameras
- Maximum current feed: up to 240V / 20A
- Image resolution (total) / pixel size: +/- 20M pixels / +/- 300μm
- Image acquisition time: <20s

3. Results

In this section, the performance data of the installation is presented of the three measurement years. This chapter consists of the simulated output, measured output, condition measurements, and end-of-measurement evaluation of the PV modules.

3.1 Energy performance simulation

The energy performance of a 1.4 kWp segment reaches 1216 kWh annually in the non-ventilated situation and 1249 kWh annually in the ventilated situation on the field test location, as indicated in Table 3. The PV performance of a ventilated and a non-ventilated BIPV roof shows a difference of 2.7 % on a yearly basis on the same location as the realized field test.

Table 3. Simulated PV output for a non-ventilated and ventilated segment on the location of the field test.

month	non-ventilated segment	ventilated segment	difference
January	36	37	1.2%
February	56	57	1.9%
March	118	121	2.6%
April	123	126	2.5%
May	152	158	4.0%
June	138	142	2.7%
July	167	173	3.3%
August	137	141	2.8%
September	114	117	2.4%
October	93	95	2.2%
November	47	48	2.5%
December	35	35	1.6%
total	1216	1249	2.7%

Table 3 indicates the lower PV performance of the non-ventilated BIPV segment compared to the ventilated BIPV segment due to the negative effect of higher operating temperatures on the performance. Moreover, this small difference increases in warmer months.

3.2 Energy performance measurements

The energy output is 1179 kWh for the double mechanical ventilated segment and 1006 kWh for the non-ventilated segment annually in the first year, 1210 kWh for the double mechanical ventilated segment and 535 kWh for the non-ventilated segment in the second year and 1112 kWh for the double mechanical ventilated segment and 160 kWh for the non-ventilated segment in the third year, as indicated in Table 4. The measured difference between the naturally ventilated segment and the non-ventilated segment is 15% in the first year and increases to 82% in the third year, as indicated on a monthly basis in Fig. 13.

Table 4. Annual measured and simulated output (kWh) per segment (simulation based on 0.5% efficiency decrease per year) over the monitoring period of 3 years.

	segment 1 (kWh) forced intermediate and natural ventilation	segment 2 (kWh) forced high and natural ventilation	segment 3 (kWh) natural ventilation	segment 4 (kWh) non- ventilated)	non-ventilated simulation (kWh)	ventilated simulation (kWh)
2013	1177	1180	1183	1006	1216	1249
2014	1167	1210	1154	535	1209	1243
2015	1094	1112	932	160	1203	1237

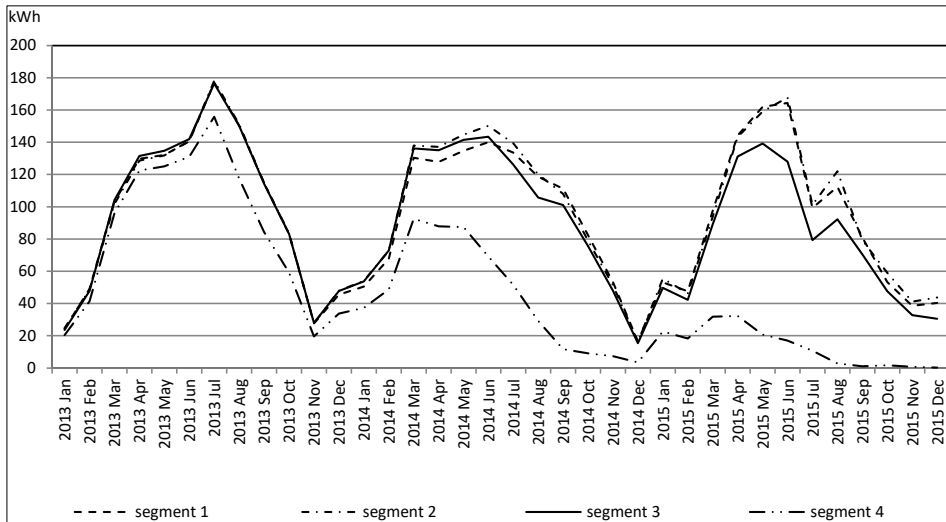

Figure 13. Monthly measured output (kWh) for the four segments over the monitoring period of 3 years.

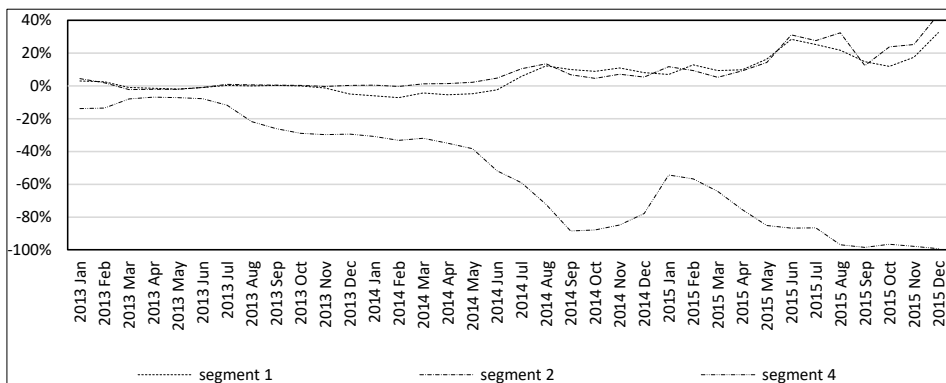

Figure 14. Monthly relative energy output for the segments 1, 2 and 4 compared to the natural ventilated segment 3, over the monitoring period of 3 years.

Fig. 13 and 14 indicate the difference between the measured output of the different segments. Moreover, the non-ventilated segment 4 shows a significant decrease of performance and the mechanical ventilated segments show a significant increase in performance, indicating a possible correlation between ventilation and lifespan of PV modules, without taking into account possible effects related to the inverter technology applied.

3.3 PV module backside temperature, air velocity, and RH measurements

Over the monitoring period, the 10 second average maximum daily temperatures measured at the back side of the PV modules occur at the top module in the non-ventilated segment 4. Temperatures above 80°C are measured in this segment with outside temperatures between 30°C and 36°C, while the daily amplitudes are over 66°C in this segment, as indicated in Fig. 15 and 16. Previous research efforts have shown temperatures of 65°C (France and Germany, ventilated BIPV roof) [33, 62], 70°C (Singapore, ventilated BIPV roof) [63], 72 °C (the Netherlands, non-ventilated BIPV roof) [36, 62], 80°C (Italy and Spain, non-ventilated) [37, 64] and 85°C (Switzerland, non-ventilated) [34]. Moreover, in the non-ventilated segment, the lowest temperatures go down to -8°C.

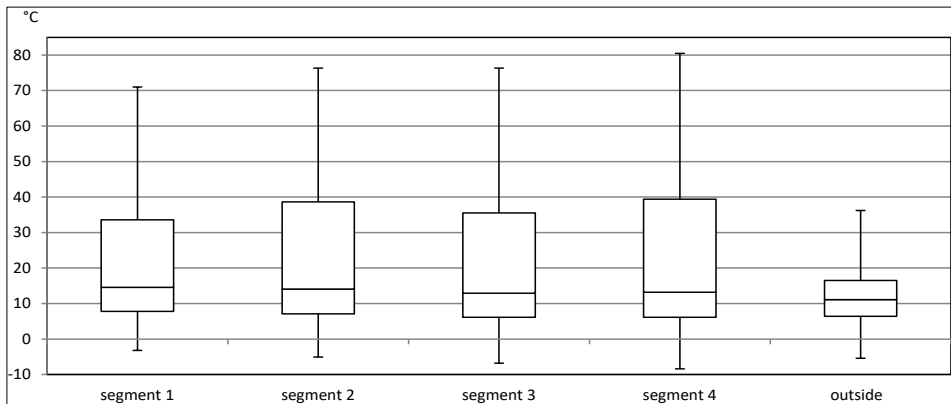

Figure 15. Box-and-whisker plot of the daily maximum and minimum module backside surface temperatures measured at the top of the segments and the outside temperatures over the monitoring period of 3 years.

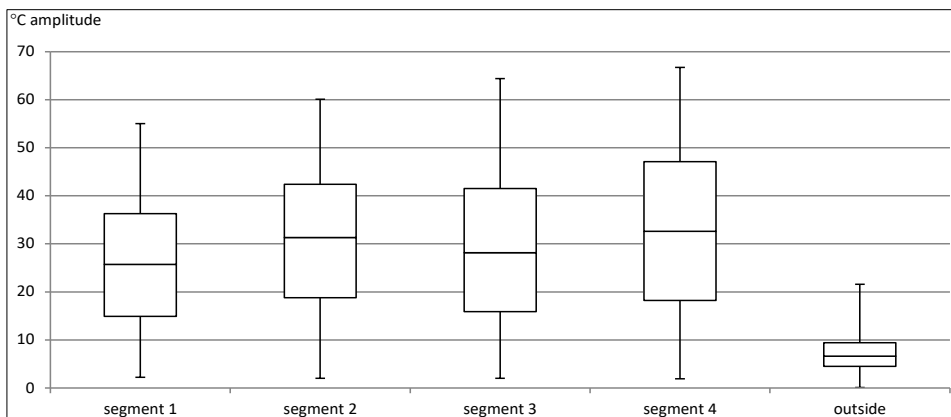

Figure 16. Box-and-whisker plot of the daily module backside surface temperature amplitudes at the top of the segments and the outside air temperature over the monitoring period of 3 years.

Over the monitoring period, the daily measured maximum relative humidity at the top of the segments shows in the mechanical ventilated segments and the non-ventilated segment 100%RH, indicating a risk of condensation, indicated in Fig. 16. Due to sensor failure, there is no reliable data of segment 3. Moreover, Fig. 17 indicates the larger bandwidth of RH levels in the non-ventilated segment.

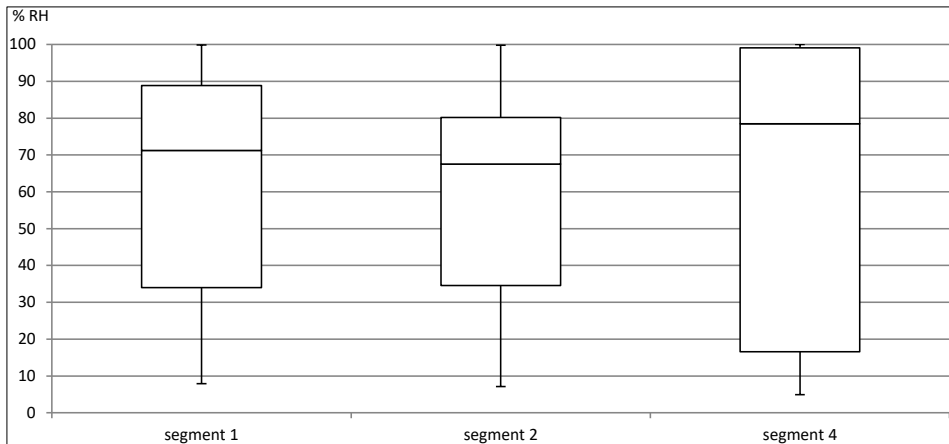

Figure 17. Box-and-whisker plot of the daily measured maximum and minimum RH in the air gap at the top of the segments over the monitoring period of 3 years.

Over the monitoring period the average air velocity in the air gap between the PV modules and the roof top was 0.04 m/s in the non-ventilated segment, 0.11 m/s in the natural ventilated segment, 0.16 m/s for the single mechanical ventilated segment, and 0.34 m/s for the double mechanical ventilated segment.

3.4 End of measurement testing of the modules

Before, during and after dismantling, none of the modules showed deterioration visually. One module was severely damaged during handling, and STC power determination and EL imaging was therefore not possible. STC power determination of the remaining modules showed a decrease between 7% in the forced ventilated segments and 60% in the non-ventilated segment, indicated in Table 5 and Fig. 18, which show the STC power (Wp) per module after the monitoring period (compared to STC initial power of 230 Wp). Comparable failures were detected in a Swiss investigation after a 12-year monitoring period [33]. In EL_v imaging, black areas indicate disconnection and failure of (part of) cells. Number of cells affected per module, based on a visual count, range between 3 in the forced ventilated segments and 58 in the non-ventilated segment, indicated in Table 5 and Fig. 19. Due to the inverter setup based on 4 string inverters with 6 modules in series, the significant difference in

STC power of the modules indicated in Table 5 and Fig. 18 influences the electrical performance.

Table 5. STC power determination of modules, power loss and numbers of cells affected (visual count of EL_v imaging).

module	power (Wp)	power loss (%)	cells affected
A1	209	9.13%	6
A2	213	7.39%	3
A3	196	14.78%	13
A4	170	26.09%	17
A5	167	27.39%	23
A6	198	13.91%	9
B1	197	14.35%	6
B2	213	7.39%	4
B3	196	14.78%	8
B4	139	39.57%	NA
B5	194	15.65%	8
B6	NA		NA

module	power (Wp)	Power loss (%)	cells affected
C1	169	26.52%	24
C2	183	20.43%	14
C3	195	15.22%	16
C4	200	13.04%	13
C5	176	23.48%	23
C6	208	9.57%	10
D1	112	51.30%	52
D2	92	60.00%	58
D3	124	46.09%	44
D4	160	30.43%	26
D5	185	19.57%	14
D6	199	13.48%	11

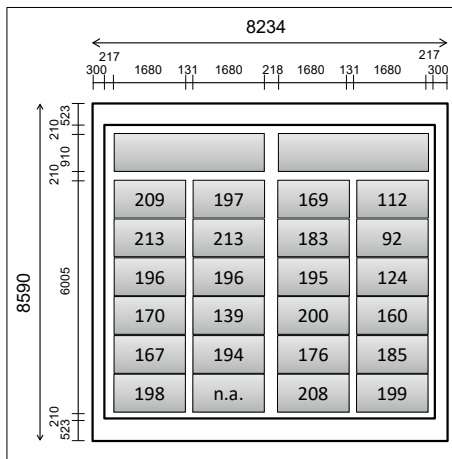

Figure 18. Rooftop overview of the four PV segments image per module.

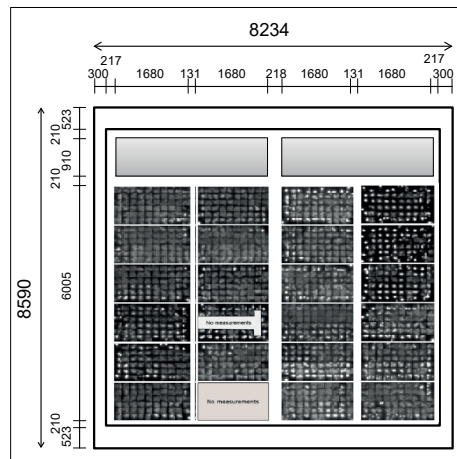

Figure 19. Rooftop overview of the four segments with EL with STC power (Wp) indicated per module.

Fig. 20 and Fig 21 are EL_v images of the best (A2) and worst (D2) module of the BIPV installation. Clearly visible in these images is the difference in the number of affected cells.

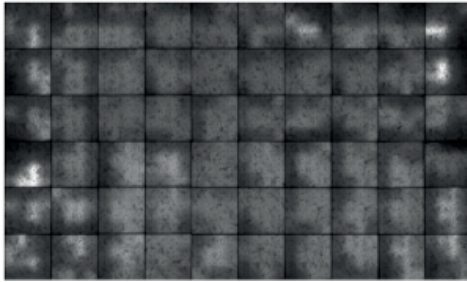

Figure 20. EL_u image of mechanical ventilated module A2.

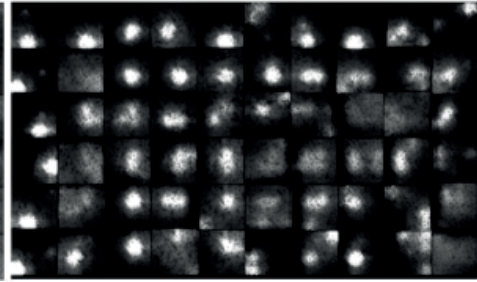

Figure 21. EL_u image of non-ventilated module D2.

4. Discussion

This paper covers the investigation of the effect of ventilation on the performance and lifespan of non-ventilated and ventilated BIPV rooftop configurations in the Netherlands.

In this study, 24 first generation MWT modules produced in 2010 have been applied in 4 different ventilation configurations and have been studied for 3 years, contributing to insight in the degradation mechanism. PV modules that are currently produced have undergone technical improvements resulting in less vulnerable MWT modules for BIPV application with less or none ventilation, and results from this study should therefore be interpreted in the context of ongoing technological development.

Performance measurements, temperature measurements, relative humidity measurements and end of monitoring EL_u imaging indicate failures in a non-ventilated BIPV configuration corresponding with failures observed in damp heating testing and temperature cycle testing. However, due to the limited number of modules tested and the real life circumstances repetitive testing is recommended. Moreover, measurements should be conducted in future research on module level to prevent effects such as electrical mismatch between modules and inverter control and create more insight in the temperature and relative humidity levels throughout the complete segments.

The EL_u imaging interpretation is based on visual counting, and this processing should undergo further refinement in order to obtain quantitative results. Moreover, EL_u imaging and independent STC power determination on site, directly before installation could provide important additional information.

Correlation with external meteorological conditions such as precipitation, wind velocities and wind direction are outside of the scope of this study, but outside air movement influence air velocities above the modules and in the air gap, affecting module temperature [28]. Moreover, precipitation affects module temperature and RH levels, while in the winter snow can influence directly the solar irradiance on the PV modules.

As BIPV modules are part of the building structure, detailing of the entrance and exit of air gaps and the BIPV support structure in the air gap has to be well designed because they affect the efficiency of the backside cooling, stressing the importance of a multidisciplinary approach between building designers and electrical technical engineers.

5. Conclusions

In the first year of monitoring, the simulated PV output difference between a ventilated and non-ventilated configuration is 3% and the measured difference is 15%. The monitored difference increases to 82% in the third year, indicating failures in the non-ventilated configuration which increase over time.

Repetitive operating temperatures of 80°C occurred in the non-ventilated configuration and daily temperature amplitudes reached 60°C in the non-ventilated configuration. Moreover, in the natural ventilated and non-ventilated configuration there is a risk of condensation due to 100% relative humidity, which could lead to moisture in the building skin if PV panels would replace the roofing material. The average air velocity in the non-ventilated segment was 13% of the air velocity in the double mechanical ventilated segment. End of monitoring STC power measurement showed a decrease of 7% Wp in the forced ventilated configuration and 60% Wp in the non-ventilated configuration. EL_v imaging showed up to 97% cell defects in a non-ventilated module, while visual end of monitoring inspection showed no results.

This study indicates a possible correlation between less ventilation, higher operating temperatures, larger daily temperature amplitudes and decreased performance of the first generation MWT PV modules under investigation (produced in 2010). Ventilation might prove to be an effective way to prevent PV modules from accumulating heat with collateral negative effects on PV output and lifespan. Results of this study should be used within the context of ongoing technological improvement of PV installations.

From a building perspective, this study indicates that combining building related mechanical ventilation outlets with PV installations proves to be an effective method to combine two installations, because in this case, the mechanical ventilation cools PV modules in the summer, heats PV modules in the winter to prevent snow accumulation and the solution prevents ducts on the rooftop that could inflict shadow on the PV modules.

This study indicates the added value of long term monitoring to support the technical improvement of PV and the acceleration of BIPV application and in future, similar studies are recommended in different climatic zones with current BIPV components to investigate the effect of ventilation on BIPV performance.

6. Acknowledgement

This research was partially funded by the Dutch Organization for Scientific Research (NWO), project number 023.001.198, and by the Foundation Innovation Alliance (SIA), project number PRO-2-015 IMDEP. The author would like to thank all participants of these projects as well as the colleagues at Zuyd; George Vervuurt[†], Alex Masolin, Sander van Heumen and Marc Dirix for supporting this study.

References

1. IEA, *Worldwide trends in energy use and efficiency*. 2008.
2. Ko, J. and L. Widder. *building envelope assessment tool for system integrated design*. in PLEA 2011. 2011. Louvain-la-Neuve, Belgium.
3. Pérez-Lombard, L., J. Ortiz, and C. Pout, *A review on buildings energy consumption information*. Energy and Buildings, 2008. 40(3): p. 394-398.
4. USEIA, *International Energy Outlook 2011*. 2011, U.S. Energy Information Administration.
5. Bruckner, M., et al., *Materials embodied in international trade – Global material extraction and consumption between 1995 and 2005*. Global Environmental Change, 2012. 22(3): p. 568–576.
6. Frontini, F. *daylight and solar control in building: a new angle selective see-thorough PV-facade for solar control*. in PLEA 2011. 2011.
7. Torcellini, P., et al., *Zero Energy Buildings: A Critical Look at the Definition*, in ACEEE Summer Study. 2006, NREL: California.
8. AgentschapNL, *Nationaal Plan voor het bevorderen van bijna-energie neutrale gebouwen in Nederland*. 2012.
9. Ho, C.J., A.O. Tanuwijaya, and C.-M. Lai, *Thermal and electrical performance of a BIPV integrated with a microencapsulated phase change material layer*. Energy and Buildings, 2012. 50(0): p. 331-338.
10. Chynoweth, P. *The built environment interdiscipline: a theoretical model for decision makers in research and teaching*. Structural Survey [conceptual paper] 2009 2009 [cited 27 4]; 301-310].
11. Mekhilef, S., R. Saidur, and M. Kamalisarvestani, *Effect of dust, humidity and air velocity on efficiency of photovoltaic cells*. Renewable and Sustainable Energy Reviews, 2012. 16(5): p. 2920-2925.
12. Davis, M.W., B. Dougherty, and A. Fannery, *Prediction of building integrated photovoltaic cell temperatures*. the Journal of Solar Energy Engineering, 2001. 123(2): p. 200-210.
13. Šúri, M., et al., *Potential of solar electricity generation in the European Union member states and candidate countries*. Solar Energy, 2007. 81(10): p. 1295-1305.
14. Defaix, P.R., et al., *Technical potential for photovoltaics on buildings in the EU-27*. Solar Energy, 2012. 86(9): p. 2644-2653.
15. Sadineni, S.B., S. Madala, and R.F. Boehm, *Passive building energy savings: A review of building envelope components*. Renewable and Sustainable Energy Reviews, 2011. 15(8): p. 3617-3631.
16. Bloem, J.J., et al., *An outdoor Test Reference Environment for double skin applications of Building Integrated PhotoVoltaic Systems*. Energy and Buildings, 2012. 50(0): p. 63-73.
17. Huang, M.J. *two phase change materials with different closed shape fins in building integrated photovoltaic system temperature regulation*. in World Renewable Energy Congress 2011. 2011. Linköping, Sweden.
18. Maturi, L., et al. *analysis and monitoring results of a BIPV system in northern Italy*. in PVSEC. 2010. Valencia, Spain.
19. Petter Jelle, B., C. Breivik, and H. Drolsum Røkenes, *Building integrated photovoltaic products: A state-of-the-art review and future research opportunities*. Solar Energy Materials and Solar Cells, 2012. 100(0): p. 69-96.
20. Tyagi, V.V., S.C. Kaushik, and S.K. Tyagi, *Advancement in solar photovoltaic/thermal (PV/T) hybrid collector technology*. Renewable and Sustainable Energy Reviews, 2012. 16(3): p. 1383-1398.
21. Gan, G., *Numerical determination of adequate air gaps for building-integrated photovoltaics*. Solar Energy, 2009. 83(8): p. 1253-1273.
22. Wang, Y., et al., *Influence of a building's integrated-photovoltaics on heating and cooling loads*. Applied Energy, 2006. 83(9): p. 989-1003.
23. Norton, B., et al., *Enhancing the performance of building integrated photovoltaics*. Solar Energy, 2011. 85(8): p. 1629-1664.
24. Gan, G., *Effect of air gap on the performance of building-integrated photovoltaics*. Energy, 2009. 34(7): p. 913-921.

25. Mei, L., et al., *Equilibrium thermal characteristics of a building integrated photovoltaic tiled roof*. Solar Energy, 2009. 83(10): p. 1893-1901.
26. Hasan, A., et al., *Evaluation of phase change materials for thermal regulation enhancement of building integrated photovoltaics*. Solar Energy, 2010. 84(9): p. 1601-1612.
27. Quesada, G., et al., *A comprehensive review of solar facades. Opaque solar facades*. Renewable and Sustainable Energy Reviews, 2012. 16(5): p. 2820-2832.
28. Brinkworth, B.J. and M. Sandberg, *Design procedure for cooling ducts to minimise efficiency loss due to temperature rise in PV arrays*. Solar Energy, 2006. 80(1): p. 89-103.
29. Kontges, M., et al., *Review of Failures of Photovoltaic Modules - Report IEA-PVPS T13-01:2014*, PVPS, Editor. 2014.
30. Rosca, V., I.J. Bennet, and W.E. Eerenstein, *Systematic reliability studies of back-contact photovoltaic modules*, in *SPIE Optics and Photonics Conference*. 2012: San Diego, USA.
31. Ndiaye, A., et al., *Degradations of silicon photovoltaic modules: A literature review*. Solar Energy, 2013. 96(0): p. 140-151.
32. Koehl, M., M. Heck, and S. Wiesmeier, *Modelling of conditions for accelerated lifetime testing of Humidity impact on PV-modules based on monitoring of climatic data*. Solar Energy Materials and Solar Cells, 2012. 99(0): p. 282-291.
33. Dittmann, S., et al., *Module characterisation of a roof integrated PV system after a 12-year operation period in the Swiss midlands*, in *31st EU-PVSEC*. 2012: Frankfurt.
34. van Kampen, B., *Actual temperatures of Building Integrated PV modules, study in the framework of the EU IP Performance project*. 2008.
35. AgentschapNL, *Gebouwintegratie zonnestroomsystemen, Praktijkvoorbeelden van succesvolle producten*. 2011.
36. Sinapsis, K., et al., *The glass-glass aesthetic energy roof: thermal behavior for various ventilation levels*, in *28th EU PVSEC*. 2013: Paris.
37. Sanchez-Friera, P., et al., *Influence of design parameters on the nominal operation cell temperature of PV modules*, in *EU-PVSEC*. 2010: Valencia, Spain.
38. NREL, *procedure for measuring and reporting the performance of photovoltaic systems in buildings*. 2005.
39. IEC, *IEC 61724 International standard photovoltaic system performance monitoring - guidelines for measurement, data exchange and analysis 1998*, IEC.
40. Pacheco, R., J. Ordóñez, and G. Martínez, *Energy efficient design of building: A review*. Renewable and Sustainable Energy Reviews, 2012. 16(6): p. 3559-3573.
41. Bahaj, A.S., *Photovoltaic roofing: issues of design and integration into buildings*. Renewable Energy, 2003. 28(14): p. 2195-2204.
42. De Lillo, A., et al. *effects of BIPV on performance*. in *PV SEC*. 2004. Paris, France.
43. Sanjuan, C., et al., *Energy performance of an open-joint ventilated façade compared with a conventional sealed cavity façade*. Solar Energy, 2011. 85(9): p. 1851-1863.
44. Fujisawa, T. and T. Tani, *Annual exergy evaluation on photovoltaic-thermal hybrid collector*. Solar Energy Materials and Solar Cells, 1997. 47(1-4): p. 135-148.
45. Ghani, F., M. Duke, and J.K. Carson, *Effect of flow distribution on the photovoltaic performance of a building integrated photovoltaic/thermal (BIPV/T) collector*. Solar Energy, 2012. 86(5): p. 1518-1530.
46. Omer, S.A., R. Wilson, and S.B. Riffat, *Monitoring results of two examples of building integrated PV (BIPV) systems in the UK*. Renewable Energy, 2003. 28(9): p. 1387-1399.
47. Yun, G.Y., M. McEvoy, and K. Steemers, *Design and overall energy performance of a ventilated photovoltaic façade*. Solar Energy, 2007. 81(3): p. 383-394.
48. Kaan, H. and T. Reijenga, *photovoltaics in an architectural context*. progress in photovoltaics: research and applications, 2004. 12: p. 395-408.
49. IEC, *IEC 1829 Crystalline silicon photovoltaic (PV) array - on-site measurement of I-V characteristics*. 1995.

50. Kottek, M., et al., *World Map of the Köppen-Geiger climate classification updated*. Meteorologische Zeitschrift, 2006. 15(3): p. 259-263.
51. KNMI. *Maastricht, langjarig gemiddelden, tijdvak 1981-2010*. 2013; Available from: http://www.klimaatatlas.nl/tabel/stationsdata/klimtab_8110_380.pdf.
52. European Commission Joint Research Centre (EC-JRC). *Photovoltaic Geographical Information System (PVGIS)*. 2015 [cited 2015 1-10].
53. Mat Desa, M.K., et al., *Silicon back contact solar cell configuration: A pathway towards higher efficiency*. Renewable and Sustainable Energy Reviews, 2016. 60: p. 1516-1532.
54. Barbato, M., et al., *Reverse bias degradation of metal wrap through silicon solar cells*. Solar Energy Materials and Solar Cells, 2016. 147: p. 288-294.
55. Solland Solar, *product data sheet*. 2010.
56. Vignola, F., F. Mavromatakis, and J. Krumsick, *performance of PV inverters*.
57. NREL, *SAM homepage*. 2014 [cited 2014 15-12-2014]; Available from: <https://sam.nrel.gov/>.
58. NREL, *SAM*. 2014; [PV system advisory model]. Available from: <https://sam.nrel.gov/>.
59. Crozier, J.L., E.E. Dyk, van, and F.J. Vorster, *High Resolution Spatial Electroluminescence Imaging of Photovoltaic Modules*. 2011.
60. Veldman, D., et al. *Non-destructive testing of crystalline silicon photovoltaic back-contact modules*. in *Photovoltaic Specialists Conference (PVSC), 2011 37th IEEE*. 2011.
61. tester, s., *mobile quality inspection for photovoltaic panels*. 2015.
62. Guiot, T., et al., *Thermal behaviour of rooftop BIPV systems: an experimental approach*, in *27th EU-PVSEC*. 2012: Frankfurt, Germany.
63. Wittkopf, S., et al., *Analytical performance monitoring of a 142.5 kWp grid-connected rooftop BIPV system in Singapore*. Renewable Energy, 2012. 47(0): p. 9-20.
64. Chatzipanagi, A., F. Frontini, and S. Dittmann, *Investigation of the influence of module working temperature on the performance of BIPV modules*, in *27th EU-PVSEC*. 2012: Frankfurt, Germany.

Chapter 7

Environmental impact comparison of a ventilated and a non-ventilated building-integrated photovoltaic rooftop design in the Netherlands: Electricity output, energy payback time, and land claim

This chapter was published as:
Ritzen, M.J., Vroon, Z.A.E.P., Rovers, R., Lupíšek, A. & Geurts, C.P.W.: *Environmental impact comparison of a ventilated and a non-ventilated building-integrated photovoltaic rooftop design in the Netherlands: Electricity output, energy payback time, and land claim*. *Solar Energy*, vol. 155, pp. 304-313, 2017

Abstract

Building Integrated PV (BIPV) is considered as a key development for successful deployment of PV in the built environment. However, the effect of PV integration on environmental impact is not fully understood. In this study a single indicator for environmental impact assessment of BIPV is investigated in the Netherlands. A BIPV rooftop with 24 multi-crystalline 60-cell modules has been designed with and without backside ventilation, and the environmental impact of these configurations has been assessed in the current situation and three future scenarios. The results are expressed in terms of electricity output difference ($\Delta_{E_{out}}$), Energy PayBack Time (EPBT), and the single indicator Land Claim (LC); the calculated claim in land-time on the carrying capacity to realize the BIPV rooftop. The EPBT calculations are based on two different datasets, SimaPro and the Inventory of Carbon and Energy (ICE), and the LC calculations are based on two different models, SimaPro and MAXergy. Calculations indicate that the ventilated BIPV rooftop design generates 2.6% more electricity than the non-ventilated BIPV rooftop design on a yearly basis. Calculations indicate that the EPBT of the ventilated BIPV rooftop design (3.56 and 4.59 years, based on SimaPro and ICE, respectively) is 9 and 6% longer than the EPBT of the non-ventilated BIPV rooftop design (3.25 and 4.32 years, based on SimaPro and ICE, respectively). Calculations indicate that the LC of a m^2 ventilated BIPV rooftop design (24.4 and 19.4 $m^2 \cdot a$, based on SimaPro and MAXergy, respectively) is 18 and 10% higher than the LC of a m^2 non-ventilated BIPV rooftop design (20.0 and 17.4 $m^2 \cdot a$, based on SimaPro and MAXergy, respectively). In the optimal future scenario EPBT might decrease to 2.06 years and LC might decrease to 10.6 $m^2 \cdot a$. This study indicates that the non-ventilated BIPV design shows a lower environmental impact in spite of a lower electric performance and that environmental impact can significantly be reduced in future scenarios.

1. Introduction

To reach lower fossil fuel dependency and to decrease CO₂ emissions in the European Union (EU), it has been agreed to increase the share of renewable energy sources in the Final Energy Consumption (FEC) to 20% by the end of 2020 [1]. Photovoltaics (PV) can be a major contributor to this target. In 2011, electricity consumption was 3,500 TWh in the EU of which 117 TWh in the Netherlands [2]. The amount of PV surface needed to cover this electricity consumption would result in a total of 7,100 km² PV modules for the EU and 1,300 km² for the Netherlands, placed in the optimum orientation and inclination [3]. This area calculation is not taking into account improved efficiency of PV systems, degradation of PV systems, grid/storage interaction and increasing electricity demand. The potential roof and façade surface for building integrated PV is a total of 4,979 km² in the EU and 210 km² in the Netherlands [4]. Theoretically, 70% of the electricity demand in the EU and 16% of the electricity demand in the Netherlands could be fulfilled by BIPV, not taking into account lower efficiencies due to less optimal inclination and orientation, degradation over time, PV efficiency improvement, grid / storage aspects, and other installation and operational aspects.

PV can easily be applied to buildings because PV installations are easily connected to the electricity system of a building and are not based on either potentially dangerous processes or use potentially dangerous resources, as opposed to for example gas based heating systems. The 60-cell multi-crystalline PV modules under investigation in this study can be added to the building envelope (Building Added PV - BAPV) or can be integrated in the building envelope (Building Integrated PV – BIPV), as illustrated in Fig. 1A and B.



Figure 1. Photograph of rooftop BAPV realized in Florianopolis, Brazil (A) [5] and photograph of rooftop BIPV realized in Badia, Italy (B) [6].

In the case of BAPV, a construction is added to the building envelope to carry the PV modules, with in general an air gap between rooftop and PV. In the case of BIPV the modules are directly placed on the rooftop construction, possibly replacing roofing materials resulting in a smaller or no air gap.

The acronym BIPV is generally used when the PV installation is both technically and aesthetically contributing to the functionality of the building [7]. Four key factors are considered essential for the success of PV: cost reduction, efficiency increase, electricity storage, and its integration in the building, i.e. BIPV [8]. One of the barriers on the track towards more BIPV is the possible negative side effect of physical integration on the performance and durability of the PV installation due to increased operating temperatures and increased relative humidity [9-12], caused by a lack of backside ventilation. For this reason, the relation between PV output and backside ventilation is an important topic of ongoing research [13]. PV application has an environmental impact, in the form of energy necessary to produce the PV installation (embodied energy – EE) and in the form of resource extraction and processing, which might increase due to a shorter lifespan of PV installations. This creates a possible imbalance between energy generation on the one hand and embodied energy and material consumption on the other hand.

The availability of resources, in combination with the renewable energy potential, to deliver the necessary operational energy and embodied energy, determines the carrying capacity⁸ of a system⁹. Overexploiting the material resources or energy resources within a system will result in either the collapse of that system or import from other systems, as described by Diamond [14]. The impact on the carrying capacity can be determined by calculating the amount of land and time needed for the extraction of raw materials, the growth of materials, the generation of power, and is expressed in Land Claim (LC) in m²-a, and is further described by Rovers [15-18] and Ritzen [19-21]. Due to the increase of material consumption with 30% between 1995 and 2005 [22], an increasing amount of land is needed for the extraction of these materials and for the generation of energy to process these materials.

Insight in the offset between energy performance and material consumption of BIPV, expressed in a single indicator related to the carrying capacity, contributes to evaluate the possible imbalance between energy performance and material consumption, which is not fully covered in current Life Cycle Assessment (LCA) methods [23]. The aim of this study is to investigate LC as a single indicator of environmental impact assessment of BIPV rooftop design in the Netherlands in the current situation and three future scenarios described in Frischknecht et al [24].

In this study, a BIPV rooftop installation has been designed in a ventilated and non-ventilated configuration. Three aspects related to the performance have been calculated; electricity output difference (ΔE_{out}), Energy PayBack Time (EPBT), and Land Claim (LC). The EPBT calculations are based on two databases, SimaPro and ICE,

⁸ In this study, the carrying capacity is defined as the ability of a system to (re)generate the resources consumed within the system itself.

⁹ A system consists of a set of interacting and/or interdependent component parts forming a whole, delineated by spatial and temporal boundaries.

and the LC calculations are made in two models, SimaPro and MAXergy, to indicate the effect of different datasets on outcome.

This paper is structured as follows. In section 2, the different methods, used to calculate electricity output and environmental impact of the designs, are presented. In section 3, the ventilated and non-ventilated BIPV rooftop designs are described. In section 4, the calculated results are presented of the different designs and the different scenarios. Finally, section 5 and 6 consist of the discussion and conclusions.

2. Methodology

In this study, a single indicator for the environmental impact assessment of BIPV is investigated. The results are expressed in electricity output difference ($\Delta_{E_{out}}$) (further described in section 2.1), and the environmental indicators Energy PayBack Time (EPBT) (further described in section 2.2) and Land Claim (LC) (further described in section 2.3) in the current situation and 3 future scenarios (further described in section 2.4). The study is conducted on a BIPV rooftop design with a ventilated and non-ventilated configuration in the Netherlands, further described in section 3. To compare the environmental impact of the non-ventilated and ventilated BIPV rooftop, the material and energy flows of the three main components (PV modules, aluminium girders and PVC roofing material) of the rooftop are taken into account, based on the selected phases and indicators of the Life Cycle Inventory (LCI) illustrated in Fig. 2. The LCI is developed in accordance with the ISO LCA protocol [26]. LCA addresses environmental impacts throughout a product's life cycle and consists of four stages; a. the goal and scope definition phase, b. the inventory analysis phase, c. the impact assessment phase, and d. the interpretation phase [26-28].

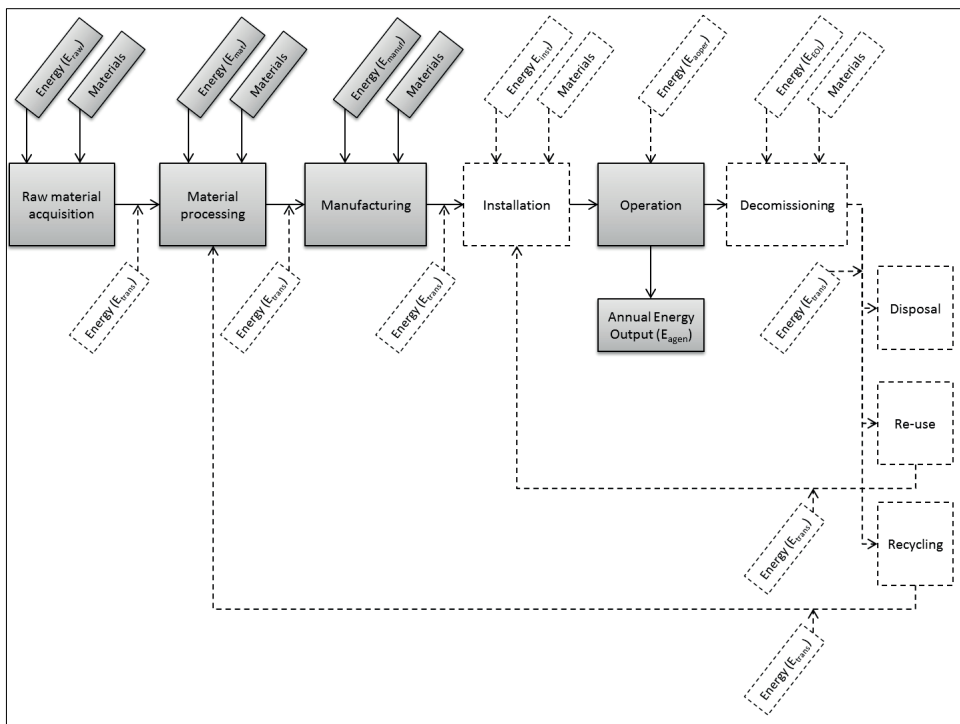

Figure 2. Life Cycle Inventory (LCI) with the different process steps and input indicators per process step of the investigated BIPV rooftop installation. Investigated process steps of this study are highlighted (based on [29-33]).

2.1 Difference in electricity output

The electricity output of the (grid connected) BIPV installation was calculated with the System Advisor Model (SAM), developed by the United States National Renewable Energy Laboratory (NREL) [34]. SAM offers the possibility to select the appropriate PV installation specifications, the appropriate meteorological data for the location, and offers different integration levels affecting backside ventilation, and thus performance [35]. The calculation in SAM covers direct and diffuse solar irradiation, temperature effects and snow coverage.

The electricity output difference ($\Delta_{E_{out}}$) (in %) between the ventilated and non-ventilated BIPV has been calculated by:

$$\Delta_{E_{out}} = \frac{E_{vent} - E_{non-vent}}{E_{non-vent}} \times 100 \quad (1)$$

2.2 Energy payback time

The Energy PayBack Time (EPBT), expressed in years, indicates how long it takes for a PV installation to produce enough electricity to generate the cumulative embodied energy required to build (and later decommission) the installation [36, 37], in contrast to the Energy Return on Investment (EROI) that indicates how much energy is generated by a system compared to the amount of energy that was needed to create the system [37].

The embodied energy refers to the energy that is necessary for the total life cycle of a material (extraction, production, transportation, and decommissioning). Existing literature shows a wide range for the embodied energy in PV modules, ranging from 1,580 MJ/m² to 16,500 MJ/m² [37-41]. This range in data originates from the differences between the individual PV products and technologies, the many process steps involved in PV module manufacturing, the different assumptions and allocation rules involved in every separate process step, calculation boundaries, geographical location and datasets available [37, 38].

The embodied energy of the BIPV rooftop was calculated with the Life Cycle Assessment (LCA) program SimaPro and based on the data of the "Inventory of Carbon & Energy" (ICE) database [39, 42]. Given the ongoing discussion on embodied energy databases and calculations [33, 43], these two datasets have been selected to indicate differences in outcomes depending on the model selected.

The amounts of embodied energy for the PV modules are 3,060 MJ/m² (derived from SimaPro) and 4,070 MJ/m² (derived from the ICE database). The numbers from these different datasets do not correspond fully with the PV modules used in the actual field case as the data from these products are not available, consequently affecting the outcomes of this study. In general, we would expect that part of this variation

is due to improvements in PV technology that would reduce the embodied energy from improvements in existing processes, introduction of new processes and use of less material to make solar cells [37]. These developments result in general in environmental impact reductions as high as 15% on a module level [44].

The EPBT has been calculated with the equation provided by IEA PVPS Task 12, covering the realization and exploitation phase of a PV system [38] (equation 2).

$$\text{Energy Payback Time (EPBT)} = (E_{\text{raw}} + E_{\text{mat}} + E_{\text{manuf}} + E_{\text{trans}} + E_{\text{inst}} + E_{\text{EOU}}) / ((E_{\text{agen}} / \eta_G) - E_{\text{oper}}) \quad (2)$$

The data provided in ICE consist of a combination of $E_{\text{raw}} + E_{\text{mat}} + E_{\text{manuf}} = E_{\text{emb}}$. Due to a lack of data for the BIPV rooftop design, the E_{trans} and E_{oper} have been left out of the scope of this study. Generally, the environmental related impact during the operation and maintenance of a PV installation are negligible [45]. Furthermore, the energy required for transportation is usually ignored [46]. This results in the following equation:

$$\text{EPBT} = \frac{E_{\text{emb}}}{E_{\text{agen}}/\eta_G} \quad (3)$$

Meta-analysis conducted by Bhandari et al resulted in a mean harmonized EPBT of a standard multi crystalline PV system between 1.5 and 3.5 years [37], while Frischknecht et al estimated in 2015 an EPBT of 2.4 years for mono crystalline PV modules in Europe [24], while Gaiddon et al estimated an EPBT of 2.9 years in 2006 for the Dutch situation [47] and de Wild-Scholten estimated an EPBT of 1.24 years for the sum of a PV system for the southern European situation [41].

2.3 Land claim

The Land Claim (LC) (in $\text{m}^2 \cdot \text{a}$) relates environmental impact to the carrying capacity of a system, and indicates the effect of a development on the resource generation capacity. The indicator provides insight in the impact a product or process has on the actual physical circumstances. But, comparable with data availability and accuracy of embodied energy data, there is a lack of complete datasets on embodied land. To gain insight into the differences in outcome between existing models, two models are applied; MAXergy and SimaPro.

2.3.1 MAXergy

MAXergy provides the direct land embodied (land and time required for the creation and extraction of a raw material) and the indirect land embodied (land and time necessary to generate the embodied energy) and the return embodied land (land and time required to fully recover the material and energy consumption) [19, 20,

48]. In this calculation, the primary process of the PV module manufacturing is taken into account based on the inventory of a PV module with multi crystalline silicon solar cells [49]. Based on the applied LCI (Fig. 2) decommissioning and collateral energy and embodied land are not covered in this research, resulting in the land claim indicator. The land claim for the BIPV installation in this calculation consists of the following (Fig. 3):

- The direct embodied land of the materials,
- The indirect embodied land of the materials by converting embodied energy in m² PV modules, and
- The direct embodied land of the PV factory.

Note that in the case of free standing PV installations, the direct embodied land of the PV modules should be taken into account as well.

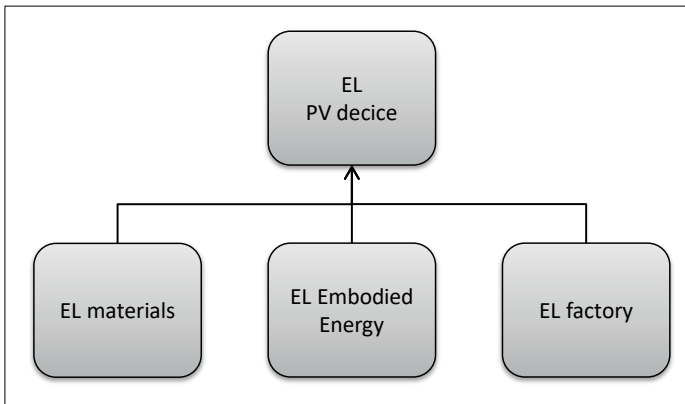

Figure 3. Overview of the Embodied Land (EL) aspects in MAXergy of the investigated BIPV rooftop solution investigated in this study, based on (based on [17, 50, 51]).

The equations applied to calculate the Embodied Land (EL) of the investigated BIPV rooftop design are (based on [52]):

$$EL_{PV} = EL_{mat} + EL_{EE} + EL_{fact} \quad (4)$$

In which:

$$EL_{EE} = EE_{tot} \cdot f \quad (5)$$

f = conversion factor (based on the amount of m² necessary to generate the embodied energy with the given installation):

$$f = E_{gen} / \text{array size (m}^2) \quad (6)$$

2.3.2 SimaPro

In SimaPro the land claim is defined as the biologically productive land and water a population requires to produce the resources it consumes and to absorb part of the waste generated by fossil and nuclear fuel consumption [53]. In the context of a Life Cycle Assessment (LCA), the land claim of a product is defined as the sum of time integrated direct and indirect land claim, related to the embodied energy. In the default setting of SimaPro, the embodied energy is based on the current energy mix of the specified country and collateral CO₂, eq. emission (e.g. EU) [53]. The land occupation claim in SimaPro is based on an elaborate lifecycle inventory, in which as many process steps as possible are included (e.g. in the case of photovoltaics 2003 processes are involved).

2.4 Scenarios

To generate insight in future development of BIPV related carrying capacity impact, in this study three scenarios are selected for 2050, based on Frischknecht et al. [24] and the grid efficiency improvement trend line of the World Energy Council [25]. The scenarios are a business as usual scenario (BAU) with limited improvement, an optimistic scenario (OPT) using the most ambitious future projections for the key parameters, and a realistic scenario (REAL) between BAU and OPT, indicated in Table 1.

In this study key parameters are the module efficiency, grid efficiency and embodied energy. In Frischknecht et al. the electricity demand for crystalline silicon production remains unchanged because no future projections of the energy demand are available [24]. However, based on Bhandari et al., a decrease of 56% in embodied energy between 2000 and 2013 has been selected as a decrease in the OPT scenario between 2013 and 2050.

Table 1. Overview of the key parameters for this study in the different scenarios; current, Business As Usual (BAU), Realistic (REAL), and Optimal (OPT).

Scenario / key parameter	PV Module efficiency (%)	Grid efficiency (%)	Module EE SimaPro (MJ/m ²)	Module EE ICE (MJ/m ²)
Current	14.8	44.5	3,060	4,070
BAU	22.9	51.5	2,488	3,309
REAL	25.2	58.5	1,916	2,547
OPT	27.6	72.5	1,346	1,791

3. BIPV rooftop design description

The BIPV rooftop installation design consists of 24 60-cell multi crystalline silicon Metal Wrap Through (MWT) PV modules, with a total capacity of 5,640 Wp, illustrated in Fig. 4, Fig. 5, and Fig. 6 [9, 54]. This study covers the following three as-

pects; PV modules, aluminium girders for the PV modules and the PVC roofing material. The comparison is made between a rain tight BIPV solution in which the airgap between the PV modules and the rooftop is sealed (making the aluminium girders and PVC roofing surplus) and a ventilated rain tight BIPV solution with a naturally ventilated air gap created with 130 mm aluminium girders between PVC roofing material and PV modules. Other building and installation components such as inverters, cables, insulation materials, etc. are left out of scope of this study.

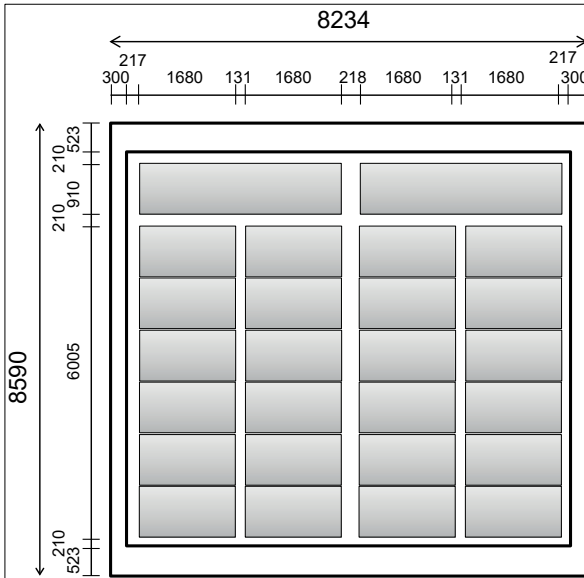

Figure 4. Top view of the BIPV rooftop design with 24 PV modules under investigation in this study (sizes in mm). Two solar thermal collectors, indicated above the 24 PV modules, are not included in this research.

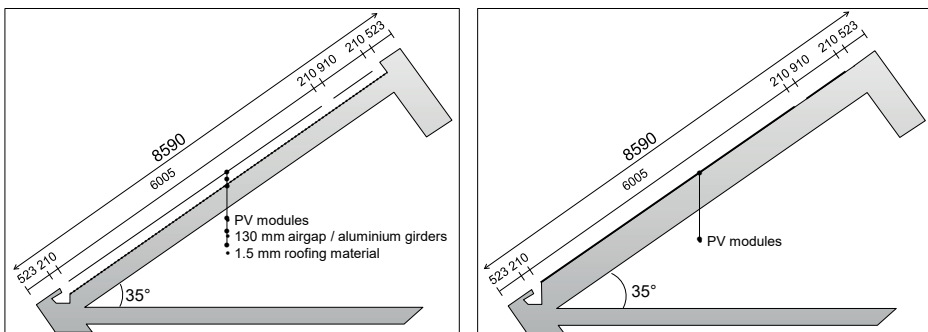

Figure 5. Technical vertical section of the ventilated BIPV rooftop design (left) and non-ventilated BIPV rooftop design (right) (sizes in mm).

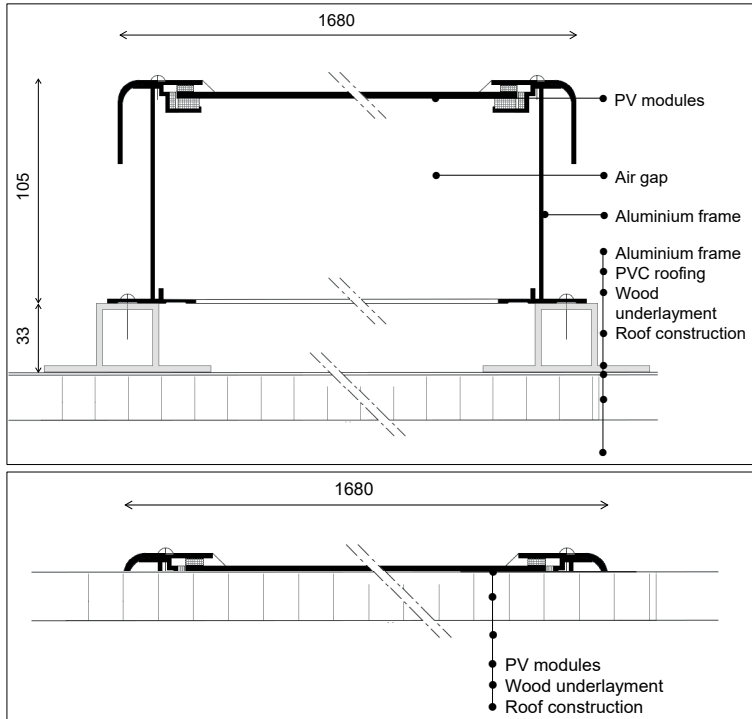

Figure 6. Technical horizontal section of the ventilated BIPV rooftop design (top) and non-ventilated BIPV rooftop design (bottom) (sizes in mm).

The experimental BIPV rooftop design is part of the development of a Real Life Learning Lab, The District of Tomorrow (TDoT) in Heerlen, the Netherlands, further in Ritzen et al [12]. The geographic location is 50°49'47" latitude, 6°1'2" longitude and 183 m altitude. In this study, weather data are derived from the official Royal Dutch Meteorological Institute (KNMI) station Beek, approx. 30 km west of the field test [55-57].

4. Results

4.1 Electricity output difference

The electricity output calculation in SAM of the 5,640 Watt peak (Wp) installation is 16,402 MJ for the ventilated BIPV rooftop design and 15,991 MJ for the non-ventilated BIPV rooftop design, indicated in Table 2. The PV output calculation of the ventilated and non-ventilated BIPV roof show a difference of 2.6% on a yearly basis due to the negative effect of higher operating temperatures. The difference is slightly higher in warmer months, indicated in Table 2 and Fig 7.

Table 2. Calculated PV output of the ventilated (vent) and non-ventilated (non-vent) BIPV rooftop design and long-term average daily temperatures [55].

month	non-vent (MJ)	vent (MJ)	difference between vent and non-vent (%)	average daily temperatures (°C)
January	428	432	0.8	2
February	698	713	2.1	1.7
March	1,498	1,534	2.4	2.5
April	1,645	1,685	2.4	8.1
May	2,041	2,120	3.9	11.5
June	1,897	1,948	2.7	15.3
July	2,207	2,272	2.9	19.2
August	1,832	1,879	2.6	18.1
September	1,544	1,577	2.1	14.4
October	1,206	1,231	2.1	12.2
November	583	594	1.9	6.7
December	410	418	1.8	5.9
total	15,991	16,402	2.6	

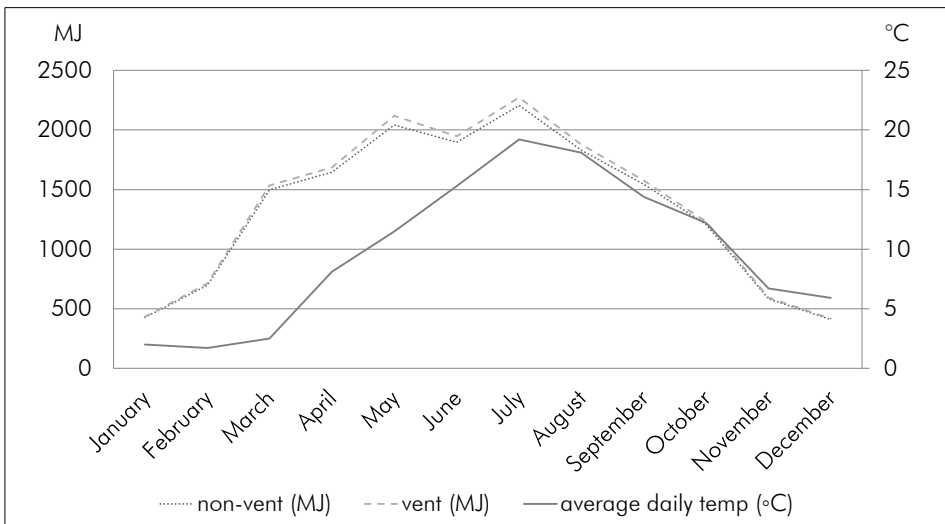

Figure 7. Calculated PV output of the ventilated (vent) and non-ventilated (non-vent) BIPV rooftop design and long-term average daily temperatures [55].

4.2 Embodied energy and energy payback time

The calculated embodied energy of the 5,640 Wp installation is 116,770 MJ in the case of the non-ventilated BIPV rooftop calculated in SimaPro and 169,341 MJ in the case of the ventilated BIPV rooftop calculated with ICE, indicated in Table 3.

Table 3. Embodied Energy (EE) of the different components in the BIPV rooftop design, based on SimaPro and the ICE database in the current situation.

component	quantity	EE SimaPro per unit	EE ICE per unit	EE rooftop SimaPro	EE rooftop ICE
PV modules	38.16m ²	3,060 MJ/m ²	4,070 MJ/m ²	116,770 MJ	155,311 MJ
130 mm aluminium girders*	41 kg	185 MJ/kg	214 MJ/kg	7,548 MJ	8,731 MJ
1.5 mm PVC roofing	77 kg	87 MJ/kg	69 MJ/kg	6,713 MJ	5,299 MJ
total Embodied Energy ventilated BIPV roof				131,031 MJ	169,341 MJ

* 100% new raw materials

The EPBT of the 5,640 Wp installation is 3.25 years for the non-ventilated BIPV rooftop design based on the SimaPro database and 4.59 years for the ventilated BIPV rooftop design based on the ICE database, indicated in Table 4. This is higher compared to a comparable study which indicates a calculated EPBT of 2.9 years for a PV rooftop system in the Netherlands [47], because in this study the aluminium girders and PVC roofing material are taken into account.

Table 4. Energy PayBack Time (EPBT) of the non-ventilated (non-vent) and ventilated (vent) BIPV rooftop design, based on SimaPro and the ICE database in the current situation.

	non-vent SimaPro	non-vent ICE	vent SimaPro	vent ICE
E_{emb} (MJ)	116,770	155,311	131,031	169,341
E_{agen} (MJ)	15,991	15,991	16,402	16,402
η_G	44.5%	44.5%	44.5%	44.5%
EPBT in years	3.25	4.32	3.56	4.59

Considering the different datasets applied, the non-ventilated BIPV installation shows a shorter EPBT than the ventilated installation, due to the offset of lower electricity generation by the lower amount of embodied energy. With increasing grid efficiency throughout the EU the EPBT of PV installations would increase, but is offset by higher efficiency and lower embodied energy in the calculated scenarios, indicated in Table 5.

Table 5. Energy PayBack Time (EPBT) of the non-ventilated (non-vent) and ventilated (vent) BIPV rooftop design, based on SimaPro and the ICE database in the different scenarios.

scenario	non-vent SimaPro	non-vent ICE	vent SimaPro	vent ICE
current	3.25	4.32	3.56	4.59
BAU	2.83	3.76	3.17	4.07
REAL	2.42	3.21	2.82	3.59
OPT	2.06	2.73	2.56	3.21

4.3 Land claim

The direct material related land claim of the 5,640 Wp installation is 178 m²·a for the non-ventilated BIPV rooftop design calculated in MAXergy and 519 m²·a for the ventilated BIPV rooftop design calculated in SimaPro, indicated in Table 6. This land claim is 17.6 m²·a per m² BIPV rooftop for the non-ventilated BIPV rooftop design calculated in MAXergy and 24.4 m²·a per m² BIPV rooftop for the ventilated BIPV rooftop design calculated in SimaPro, indicated in Table 7.

Table 6. Embodied Land (EL) and Land Claim (LC) of the different materials in the investigated BIPV roof design, based on SimaPro and MAXergy in the current situation.

component	quantity	EL SimaPro per unit	EL MAXergy per unit	LC SimaPro	LC MAXergy
PV modules	24 modules	15.8 (m ² ·a) / module	7.4 (m ² ·a) / module	379 (m ² ·a)	178 (m ² ·a)
130 mm aluminium girders*	41 kg	1.18(m ² ·a) /kg	0.5 (m ² ·a) /kg	74 (m ² ·a)	20 (m ² ·a)
1.5 mm PVC roofing	77 kg	0.85(m ² ·a) /kg	0.16 (m ² ·a) /kg	66 (m ² ·a)	12 (m ² ·a)
total Embodied Land (m ² ·a) ventilated BIPV roof				519 (m ² ·a)	210 (m ² ·a)

* 100% new raw materials.

Table 7. Land Claim (LC) of the ventilated (vent) and non-ventilated (non-vent) BIPV rooftop design, based on SimaPro and MAXergy in the current situation.

	non-vent SimaPro	non-vent MAXergy	vent SimaPro	vent MAXergy
EL _{mat} (m ² ·a)	10.0	4.6	13.6	5.6
EL _{fact} (m ² ·a)	0.8	0.8	0.8	0.8
EL _{EE} (m ² ·a)	9.2	12.2	10	13
total LC (m ² ·a)	20.0	17.6	24.4	19.4

Note: the PV modules in the SimaPro calculation consist of framed modules and the PV modules in the MAXergy calculation consist of frameless modules. Excluding the frame in the SimaPro calculation would result in a lower LC per quantity of approx. 3.28 (m²·a) per m² module (5.2 m 130 mm aluminium girder), resulting in a smaller difference between SimaPro and MAXergy calculation.

In both calculation methods, the non-ventilated BIPV shows a lower LC. In the current situation and the future scenarios, the LC is 26.2 m²·a for the ventilated BIPV rooftop design in the BAU scenario calculated in SimaPro and 10.6 m²·a for the non-ventilated BIPV rooftop design in the OPT scenario calculated in MAXergy, indicated in Table 8. The scenario and calculation method selection results in a 2.4 fold difference.

Table 8. Land Claim (LC) of the ventilated (vent) and non-ventilated (non-vent) BIPV rooftop design, based on SimaPro and MAXergy in the different scenarios.

scenario	non-vent SimaPro	non-vent MAXergy	vent SimaPro	vent MAXergy
current (m ² · a)	20.0	17.6	24.4	19.4
BAU (m ² · a)	21.4	19.6	26.2	21.6
REAL (m ² · a)	17.8	14.8	22.6	16.8
OPT (m ² · a)	14.6	10.6	19.2	12.4

Note: In the BAU scenario LC increases due to the effect of a relative low improvement of the grid efficiency and collaterally high amount of LC for the generation of EE in the PV modules.

To prevent an overexploitation of the carrying capacity of a system, the claim of the development itself, in this case a BIPV installation, should be less than the availability in the system. We could refer to this balance as 'land parity', in this investigation the situation that the land claim is equal or less than the availability of surface. Based on this investigation and a lifespan of 20 years for the BIPV design, land parity is reached in a number of designs and scenarios, because the LC of the BIPV solution does not exceed the available carrying capacity (m²·a) in the system.

5. Discussion

This paper covers the results of a comparative study on the simulated electricity output and calculated environmental impact to investigate a carrying capacity based single indicator for environmental assessment of BIPV.

Installation aspects such as transportation (e.g. E_{trans}) and operating aspects such as maintenance (e.g. E_{oper}), decrease of PV lifespan due to temperature fluctuations and relative humidity fluctuations have been left out of this study. Besides, material alternatives, covering different PV technologies and alternatives for aluminium girders, as well as financial, social and other non-technical issues have been left out of the scope of this study. Including these steps and aspects would influence environmental impact.

As fully integrated BIPV components are an integral part of the building skin (according to EN 50583: ...Photovoltaic modules are considered to be building-integrated, if the PV modules form a construction product providing a function as defined in the European Construction Product Regulation CPR 305/2011... [58]) damage and removal would not only affect the environmental impact of the BIPV rooftop itself, but would have as well affect building physical characteristics, such as insulation characteristics, water proofing and vapour characteristics.

This study has not included the decommissioning phase and collateral return energy use. Including this step, based on a full circular situation in which the full cycle of energy and material is closed, will lead to a full overview of environmental impact

related to the physical carrying capacity, generating the insight to design according to the capabilities of our system.

In this study key parameters are the module efficiency, grid efficiency, embodied energy and material selection. The exact data of the PV modules used in the actual field case are not available, consequently affecting the outcomes of this study. Variation in one or more of the parameters would influence the environmental impact as well, for instance the replacement of the aluminium supportive girders by bamboo. Moreover, the selection of method used has significant impact on the results, indicating future research needs.

In Frischknecht et al. three future scenarios have been investigated covering PV efficiency and material consumption for PV manufacturing [24]. Bhandari et al. indicates a decrease of 56% in embodied energy between 2000 and 2013 [37]. Improvements in existing processes, introduction of new processes and use of less material to make solar cells will result in overall environmental impact reductions as high as 15% on a module level [37, 44].

Due to the increased PV efficiency, in future scenarios, a smaller amount of PV modules might be necessary to comply with the electricity demand of the building, if the efficiency improvement is larger than electricity demand increase. However, from a building and architectural perspective, a homogenous roof coverage results in an aesthetic higher valued building object and in a technical less complex building object.

This study is based on a comparison including grid efficiency and Primary Energy Consumption (PEC). In the development towards 0-energy buildings, autonomic buildings and other non-fossil related energy generation, only the final energy consumption (FEC) will become a more relevant aspect and will influence both EPBT and LC impacts [59].

The SimaPro land occupation and land transformation calculations are very elaborate with 2003 calculation nodes in the calculation of PV modules. This results in very specific insight and influence possibilities in the process. However, the calculation in SimaPro is very complex to alter and it is very difficult to have a throughout view on the whole process and underlying calculations. For example, it is not possible to adjust the energy fuel mix in a single handling. As an indication, changing the energy mix to 100% renewable (PV for electricity and thermal ground heat for heat) in the first 6 most influential process phases of PV manufacturing, results in a decrease of LC of 1 m²·a per PV module.

On the other hand, the MAXergy LC calculation is based on the database of the University of Bath and uses peer reviewed references in one calculation, resulting in a more comprehensive calculation, but which depends more on stochastic values. Data used in this investigation show a large bandwidth or results, for instance the range of embodied energy of PV modules, and the sources show gaps in data collection regarding the claim on carrying capacity, for instance regarding chemical gases. In this research, the main PV components have been taken into account.

To make the next step in using LC as an addition to, or replacement of, current environmental building assessment tools and to be able to develop buildings based on the carrying capacity of the physical system, a coherent framework for carrying capacity based environmental assessment has to be developed. This framework would contribute to the transparency and relevance of the investigated tools. In a second step, validation of land claim through specific field cases should be conducted; based on long term monitoring and including effects of the (lack of) ventilation on lifespan.

6. Conclusions

Calculations in this study indicate that the investigated ventilated BIPV rooftop design generates 2.6% more electricity than the non-ventilated BIPV rooftop design on a yearly basis in the Netherlands. Calculations indicate that the EPBT of the ventilated BIPV rooftop design is 9 and 6% longer than the EPBT of the non-ventilated BIPV rooftop design, based on respectively SimaPro and ICE. Calculations indicate that the LC of the ventilated BIPV rooftop design is 18 and 10% higher than the LC of the non-ventilated BIPV rooftop design, based on respectively SimaPro and ICE. This indicates that the combination of lower material consumption and lower electricity generation of a non-ventilated BIPV installation has an overall lower environmental impact compared to a ventilated BIPV installation, but that the selected calculation method and dataset has significant influence on the outcome.

The future scenarios indicate that due to higher module efficiencies, higher grid efficiencies and lower embodied energy in PV modules the EPBT might decrease with 28-37% in the OPT scenario, compared to the current situation and LC might decrease with 21-40% in the OPT scenario, compared to the current situation. In all scenarios, the non-ventilated BIPV design shows lower environmental impacts than the ventilated BIPV design, but the selected calculation method and dataset has significant influence on the outcome.

This study is of value for the acceleration of BIPV application as one the tracks in the realization of a sustainable built environment because it indicates with this single indicator that PV modules integrated in the building envelope lead to not only an aesthetic more accepted solution but that it has environmental advantages as well. In future research, different PV technologies, different integration solutions, and different materials in BIPV application will have to be analysed to fully map the field of BIPV related environmental impact.

7. Acknowledgement

This research was partially funded by the Dutch Organization for Scientific Research (NWO), project number 023.001.198, by the Foundation Innovation Alliance (SIA), project number PRO-2-015 IMDEP, and by the European Union / Czech Republic (project number CZ.1.05/2.1.00/03.0091) . The author would like to thank all participants of these projects, Jos Houben and Bert Blocken for supporting this study.

References

1. European Commission, *Europe 2020 - A strategy for smart, sustainable and inclusive growth* 2010: Brussels.
2. European Commission, *Energy, transport and environment indicators - 2013 edition*. 2013, Eurostat: Luxembourg. p. 247.
3. Šúri, M., et al., *Potential of solar electricity generation in the European Union member states and candidate countries*. *Solar Energy*, 2007. 81(10): p. 1295-1305.
4. Defaix, P.R., et al., *Technical potential for photovoltaics on buildings in the EU-27*. *Solar Energy*, 2012. 86(9): p. 2644-2653.
5. Santos, Í.P.d. and R. Rütther, *The potential of building-integrated (BIPV) and building-applied photovoltaics (BAPV) in single-family, urban residences at low latitudes in Brazil*. *Energy and Buildings*, 2012. 50: p. 290-297.
6. GSE, *Catalogue of Photovoltaic Plants Integrated with Innovative Characteristics*. 2012.
7. Sinapsis, K. and M.v.d. Donker, *BIPV Report 2013, State of the art in Building Integrated Photovoltaics*, SEAC, Editor. 2013, Solar Energy Application Centre: Eindhoven.
8. Raugei, M. and P. Frankl, *Life cycle impacts and costs of photovoltaic systems: Current state of the art and future outlooks*. *Energy*, 2009. 34(3): p. 392-399.
9. Ritzen, M., et al., *Comparative performance assessment of four BIPV roof solutions in the Netherlands*, in *ICBest 2014*. 2014: Aachen.
10. Mei, L., et al., *Equilibrium thermal characteristics of a building integrated photovoltaic tiled roof*. *Solar Energy*, 2009. 83(10): p. 1893-1901.
11. Norton, B., et al., *Enhancing the performance of building integrated photovoltaics*. *Solar Energy*, 2011. 85(8): p. 1629-1664.
12. Ritzen, M.J., et al., *Comparative performance assessment of a non-ventilated and ventilated BIPV rooftop configurations in the Netherlands*. *Solar Energy*, 2017. 146: p. 389-400.
13. Ritzen, M., et al. *Development, realization and monitoring of 2 BIPV field tests in the Netherlands*. in *29th European Photovoltaic Solar Energy Conference and Exhibition*. 2014. Amsterdam, the Netherlands.
14. Diamond, J., *Collapse, how societies choose to fail or succeed*. 2005, United States: Viking Press.
15. Rovers, R. *0-material building: space time analyses*. in *SB10*. 2010. Maastricht, the Netherlands.
16. Rovers, R., *Exergy is not only about energy*. 2011.
17. Rovers, R., *MAXergy and embodied land*, RiBuiT, Editor. 2011.
18. Rovers, R., et al. *designing for only energy: suboptimisation*. in *PLEA 2011*. 2011. Louvain-la-Neuve, Belgium.
19. Ritzen, M., et al., *Comparison and development of sustainable office façade renovation solutions in the Netherlands*. *Journal of Facade Design and Engineering*, 2013. 1(1): p. 53-71.
20. Ritzen, M., et al., *Making the assessment right, or making the right assessment*, in *Architecture and Sustainability*. 2014.
21. Ritzen, M.J., et al., *Environmental impact evaluation of energy saving and energy generation: Case study for two Dutch dwelling types*. *Building and Environment*, 2016. 108: p. 73-84.
22. Bruckner, M., et al., *Materials embodied in international trade – Global material extraction and consumption between 1995 and 2005*. *Global Environmental Change*, 2012. 22(3): p. 568–576.
23. Keoleian, G.A. and G.M. Lewis, *Modeling the life cycle energy and environmental performance of amorphous silicon BIPV roofing in the US*. *Renewable Energy*, 2003. 28(2): p. 271-293.
24. Frischknecht, R., R. Itten, and F. Wyss, *Life Cycle Assessment of Future Photovoltaic Electricity Production from Residential-scal Systems Operated in Europe*. 2015, IEA PVPS Task 12.
25. World Energy Council, *Efficiency of power generation*. 2015 [cited 2015 8-12-2015]; Available from: <https://www.wec-indicators.enerdata.eu/power-generation-efficiency.html>.
26. ISO, *ISO 14044:2006(en) Environmental management — Life cycle assessment — Requirements and guidelines*. 2006.

27. ISO, *ISO 14001 in 7 steps*. 2013; Available from: <http://www.iso14000.nl/zeven.html>.
28. Peng, J., L. Lu, and H. Yang, *Review on life cycle assessment of energy payback and greenhouse gas emission of solar photovoltaic systems*. *Renewable and Sustainable Energy Reviews*, 2013. 19: p. 255-274.
29. Rebitzer, G., et al., *Life cycle assessment: Part 1: Framework, goal and scope definition, inventory analysis, and applications*. *Environment International*, 2004. 30(5): p. 701-720.
30. Fthenakis, V., W. Wang, and H.C. Kim, *Life cycle inventory analysis of the production of metals used in photovoltaics*. *Renewable and Sustainable Energy Reviews*, 2009. 13(3): p. 493-517.
31. Ramesh, T., R. Prakash, and K.K. Shukla, *Life cycle energy analysis of buildings: An overview*. *Energy and Buildings*, 2010. 42(10): p. 1592-1600.
32. Dixit, M.K., et al., *Identification of parameters for embodied energy measurement: A literature review*. *Energy and Buildings*, 2010. 42(8): p. 1238-1247.
33. Dixit, M.K., et al., *Need for an embodied energy measurement protocol for buildings: A review paper*. *Renewable and Sustainable Energy Reviews*, 2012. 16(6): p. 3730-3743.
34. NREL, *SAM homepage*. 2014 [cited 2014 15-12-2014]; Available from: <https://sam.nrel.gov/>.
35. NREL, *SAM*. 2014; [PV system advisory model]. Available from: <https://sam.nrel.gov/>.
36. Raugei, M., P. Fullana-i-Palmer, and V. Fthenakis, *The energy return on energy investment (EROI) of photovoltaics: Methodology and comparisons with fossil fuel life cycles*. *Energy Policy*, 2012. 45(0): p. 576-582.
37. Bhandari, K.P., et al., *Energy payback time (EPBT) and energy return on energy invested (EROI) of solar photovoltaic systems: A systematic review and meta-analysis*. *Renewable and Sustainable Energy Reviews*, 2015. 47(0): p. 133-141.
38. Fthenakis, V.M., et al., *Life Cycle Inventories and Life Cycle Assessment of Photovoltaic Systems*. 2011, International Energy Agency (IEA) PVPS Task 12.
39. Hammond, G.J., C., *Inventory of Carbon and Energy (ICE)*. University of Bath, UK, 2008.
40. Hammond, G. and C. Jones, *Inventory of Carbon & Energy (ICE)*. 2011, University of Bath, UK: Bath, UK.
41. de Wild-Scholten, M.J., *Energy payback time and carbon footprint of commercial photovoltaic systems*. *Solar Energy Materials and Solar Cells*, 2013. 119: p. 296-305.
42. Pré consultancy, *Simapro website*. 2014 [cited 2014 18-12]; Available from: <http://www.pre-sustainability.com/simapro>.
43. Hodvoka, J., *Assessment of building materials in environmental context*, in *Faculty of Civil Engineering 2013*, Czech Technical University in Prague: Prague. p. 263.
44. Alsema, E.A., M.J. de Wild-Scholten, and V.M. Fthenakis, *Environmental Impacts of PV Electricity Generation - A Critical Comparison of Energy Supply Options.*, in *EU PVSEC*. 2006: Dresden, Germany.
45. Alsema, E.A. and M. de Wild-Scholten. *Environmental Impacts of Crystalline Silicon Photovoltaic Module Production*. in *13th CIPR international conference on Life Cycle Engineering*. 2006. Leuven, Belgium.
46. De Decker, K. *How Sustainable is PV Solar Power?* 2015; Available from: <http://www.lowtechmagazine.com/2015/04/how-sustainable-is-pv-solar-power.html>.
47. Gaiddon, B. and M. Jedliczka, *Compared assessment of selected environmental indicators of photovoltaic electricity in OECD cities*. 2006, IEA PVPS Task 10.
48. Ritzen, M.G., Leo; Rovers, Ronald; Geurts, Chris; Vroon, Zeger; Sigwarth, Stefan. *Insulation versus installation - an exploration towards maximization*. in *SB 13 Implementing sustainability - barriers and chances*. 2013. Munich: Fraunhofer IRB.Verlag.
49. Pacca, S., D. Sivaraman, and G.A. Keoleian, *Life Cycle Assessment of the 33 kW photovoltaic system on the Dana Building at the University of Michigan± thin film laminates, multi/crystalline modules, and balance of system components*. 2006, University of Michigan. p. 87.
50. Frischknecht, R. and N. Jungbluth, *Ecoinvent data v2.0 overview and methodology*. 2007.
51. Weidema, B.P., et al., *Overview and methodology. Data quality guideline for the ecoinvent database version 3*. *Ecoinvent Report 1 (v3)*. 2013.

Chapter 7

52. Ritzen, M.J., et al., *Carrying capacity based environmental impact assessment model development for Building Integrated Photovoltaics*. under review, 2017.
53. Pré Consultancy, *SimaPro Database Manual Methods library*. 2014.
54. Ritzen, M.J., et al., *Comparative performance assessment of a non-ventilated and ventilated BIPV rooftop configurations in the Netherlands*. under review, 2016.
55. KNMI., *Maastricht, langjarig gemiddelden, tijdvak 1981-2010*. 2013; Available from: http://www.klimaatatlas.nl/tabel/stationsdata/klimtab_8110_380.pdf.
56. ASHRAE, *International Weather for Energy Calculations (IWEC Weather Files) Users Manual and CD-ROM*, ASHRAE, Editor. 2001.
57. ASHRAE, *typical weather data Beek, NL*, ASHRAE, Editor. 2014.
58. CEN-CENELEC, *NEN-EN 50583-1 Photovoltaics in buildings - Part 1: BIPV modules*. 2016: Brussels.
59. Rovers, R., *Zero-Energy and Beyond: A Paradigm Shift in Assessment*. *Buildings*, 2014. 5(1): p. 1-13.

Chapter 8

Carrying capacity based environmental impact assessment of Building Integrated Photovoltaics

This chapter is submitted as:
Ritzen, M.J., Rovers, R., Vroon, Z.A.E.P. & Geurts, C.P.W.: *Carrying capacity based environmental impact assessment of Building Integrated Photovoltaics.*

Abstract

To fulfil (part of) the electricity demand of buildings, photovoltaics (PV) can be added to the building envelope (BAPV) or integrated in the building envelope (BIPV). To assess the environmental impact of different PV technologies, Life Cycle Assessment (LCA) tools are applied. However, a carrying capacity based LCA is still to be developed for BIPV solutions. In this study, the carrying capacity is defined as the ability of a system to (re)generate the resources consumed within the system itself, and consequently environmental impact can be expressed in the claim on carrying capacity. The LCA method has been applied to formulate carrying capacity based environmental assessment equations. The equations can be embedded in environmental assessment tools or used stand-alone. In this study, the equations are applied for three different PV technologies; Multi-Si, Amorf-Si, and copper indium gallium (di) selenide (CIGS), in three different BIPV rooftop configurations; non-ventilated, ventilated with an aluminium construction and ventilated with a bamboo construction. The assessment covers three end-of-life scenarios; reusing, recycling and circulation. The conclusions of the assessment are that 1 m² Amorf-Si bamboo ventilated configuration shows the lowest environmental impact of 3,700 m²·a, given the investigated BIPV configurations with current maximum recycling percentages of PV technologies. To lower the claim on carrying capacity, reusing and recycling percentages have to be improved and non-renewable resources have to be eliminated or replaced by renewable resources. With 100% recycling, 1 m² non-ventilated Amorf-Si configuration shows the lowest environmental impact of 7.44 m²·a, given the investigated BIPV configurations.

1. Introduction

The realisation and operation of the built environment is based on the exploitation of biotic resources, such as wood, and abiotic resources, such as minerals and fossil fuels [1, 2]. Currently, the built environment is responsible for 40% of final energy consumption in the European Union (EU) [3]. Moreover, embodied energy in buildings accounts for up to 60% of the building's life cycle energy [4]. Within the EU, more than 50% of all extracted materials are attributed to buildings [5]. Consequently, the exploitation of natural resources and its collateral environmental impact is seen as a serious threat to our natural, social and economic systems [2], and renewable energy technologies are needed to overcome this challenge [6].

The EU roadmap towards a resource efficient Europe highlights how a more sustainable construction sector in the EU could lower final energy consumption with approximately 42% [7]. As part of the strategy to reach this goal, all new buildings within the EU should be nearly Zero Energy Buildings (*nZEB*) by the end of 2020 and existing buildings should be *nZEB* by the end of 2050 [8, 9]. Two commonly applied measures to reach the level of *nZEB* are energy saving by thermal insulation of the building envelope and energy generation by photovoltaic (PV) systems [10]. PV systems can either be added to the building envelope (BAPV) or integrated in the building envelope (BIPV). In this study the term BIPV is used for an installation that is technically integrated in the building envelope and contributes to the aesthetic value of the building while being able to generate electricity. BIPV systems do not only fulfill (part of) the operational electricity demand, but have building envelope functions as well, such as waterproofing and/or thermal insulation [6, 11-18].

To reach the goal of *nZEB* vast areas of land are needed for urban, agricultural and forestry purposes to extract the necessary resources [19]. Moreover, an increasing area of land is being occupied for renewable energy generation. By extracting non-renewable resources and by extracting renewable resources without renewing them, we reduce the quantity of the remaining resources [19, 20]. In many countries the generation of resources within their own borders does not meet the consumption of resources, which leads to inequality and intensifying of international competition [2, 21]. Land area demand can exceed land area availability, and from an ecological point of view, there is a limit that cannot be exceeded without consequences on the short and/or long term [20]. The increasing speed of extraction of resources indicates that the future potential biophysical carrying capacity is reduced by depleting essential natural resources [22]. The carrying capacity is a function of characteristics of both the area and the process [22]. In this study, the carrying capacity is defined as the ability of a system to (re)generate the resources consumed within the system itself. An environmental impact indicator related to carrying capacity is land use [23], and is already covered in a number of assessment tools regarding direct land use, and based on the assumption that resources are infinitely available [2]. A

widely accepted assessment method covering both direct land occupation and indirect land use has still to be fully developed [24]. Carrying capacity based environmental impact covering direct and indirect land use is expressed in Embodied Land (EL), the time and land ($\text{m}^2 \cdot \text{a}$) necessary to convert solar energy (as the primary energy source [25]) in operating energy, biotic resources, and Embodied Energy (EE) consumed in all life cycle stages. EL is a single non-weighted indicator and can be calculated with the MAXergy approach, developed at the Wageningen University and the Zuyd University of Applied Science [23, 26-28].

There is a large number of methods and tools to fully or partly assess environmental impact [2, 6, 29-37]. According to the European Parliament, 'Environmental impact' means any change to the environment wholly or partially resulting from a product during its life cycle [38]. A widely applied method to do so is based on Life Cycle Assessment (LCA). LCA is a method that enables the quantification of environmental impact in different impact indicators throughout a product's life cycle from resource extraction through processing, transport, and exploitation until its end-of-life, according to [39]. An LCA can contribute to support a decision in a comparison between design solutions [40]. However, normalization between different impact indicators should be used with caution because weighting influences the objectivity of the results [41].

Until now, environmental impact assessment of PV technologies and their integration in the building envelope have mainly had the purpose to document environmental impact of specific technologies and to identify environmental bottlenecks [6]. However, a carrying capacity based environmental impact assessment method for BIPV has still to be fully developed [6, 42].

The aim of this study is to develop the equations of the carrying capacity environmental assessment for BIPV based on the non-weighted single indicator embodied land and to assess the environmental impact of different BIPV rooftop configurations with these equations.

2. Methodology

To develop the carrying capacity based environmental impact equations, the LCA method has been applied [39], based on the circular life cycle process in the built environment, as indicated in Fig. 1.

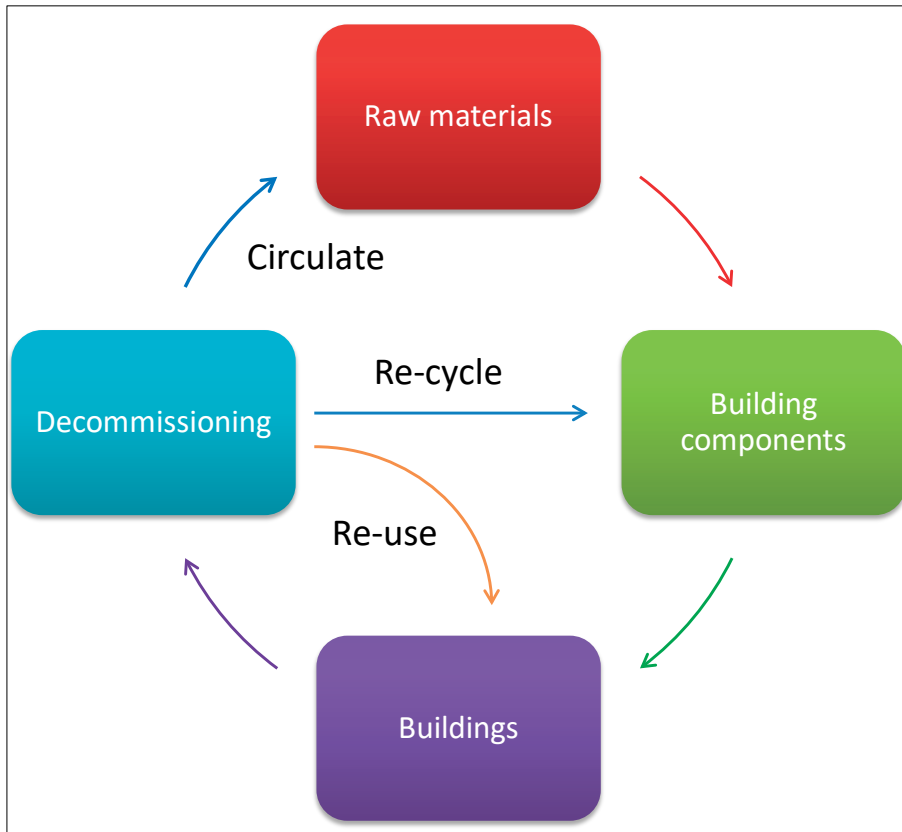

Figure 1. Circular life cycle process in the built environment on which this study is based.

The application of the LCA method in this study consists of four stages; goal and scope definition, inventory analysis, impact assessment equations, and application, further described in section 2.1-2.3 and chapter 3:

- 2.1 Goal and scope definition; during the first stage the goal of the LCA is described and the system boundaries are determined.
- 2.2 Inventory analysis; in the second stage, the main product variables are specified that influence the environmental impact.
- 2.3 Impact assessment equations; in the third stage, the Life Cycle Inventory (LCI) phases included in this study are specified and the environmental impact equations are formulated.
3. Application: in the fourth stage, the environmental impact equations formulated in section 2.3 are applied on the different BIPV configurations described in 2.1-2.2.

To cover the circulate stage indicated in Fig. 1, material extraction from ocean water is selected for abiotic materials. The ocean route can be seen as the ultimate cycle of materials due to washing out of materials (e.g. sand and gravel) and dissolving of metals (e.g. steel and aluminium). Consequently, the oceans contain vast amounts of

materials and dissolved metals which could be extracted [43]. The oceans can be seen as an infinite source of a number of materials that could be used for closing the cycle of material consumption and reaching long term sustainability [43], but resource availability differs geographically and through time. By 2020, 5% of the world's minerals could come from the ocean seabed [44]. To extract these materials, large amounts of ocean water need to be processed [43], and a large amount of energy is needed for the filtering of the ocean water [43, 45]. In this study, the environmental impact related to the circular route is included covering the energy consumption related to the filtering of ocean water to recuperate the abiotic materials and minerals.

2.1 Goal and scope definition

The goal of this study is to assess the carrying capacity environmental impact of different BIPV rooftop configurations further described in section 2.2, and to be able to compare the environmental impact of different technologies and integration configurations.

To reach this goal, the carrying capacity based environmental impact of 1 m² different BIPV rooftop configurations is assessed in this study. The different configurations are based on a BIPV configuration realised in the Real Life Learning Lab 'The District of Tomorrow' (TDoT) in the Netherlands [46]. In the realised configuration, illustrated in Fig. 2 and Fig. 3, the BIPV rooftop consists of six 60-cell modules in landscape orientation above each other, in a ventilated / non-ventilated configuration on top of an insulated roof. Included in this study are the following three layers: PV, airgap and water barrier, illustrated in Fig. 2. The possible configurations of the BIPV component are the result of a theoretical study focused on the energy performance in a ventilated and non-ventilated configuration [46].



Figure 2. Realised BIPV rooftop field test in The District of Tomorrow.

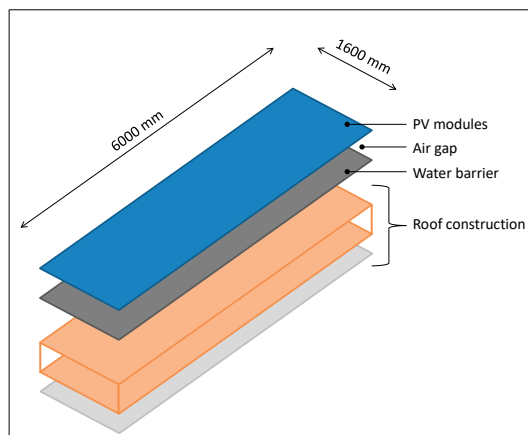

Figure 3. BIPV rooftop component under investigation in this study.

The scope of this study is the first cycle environmental impact of a BIPV rooftop of a grid connected ZEB [47], in the Dutch environment, without compensation for grid losses, storage of energy, etc.

2.2 Inventory analysis

To assess the carrying capacity based environmental impact of different BIPV rooftop configurations, the following variables are specified which influence the environmental impact, and are described in section 2.2.1-2.2.4:

- PV technology
- Airgap height and materialization
- PV system output
- PV array size

2.2.1 PV technology

To carry out the assessment, three main PV technologies are investigated; multi crystalline silicon (Multi-Si), amorphous crystalline silicon (Amorf-Si), and copper indium gallium (di) selenide (CIGS).

Currently, Multi-Si based PV technology is the most applied PV technology [48], with a market share of about 68% of total production in 2015 [49], mainly with 'standard' PV modules of 6x10 cells [50]. In this study, a maximum lifespan of the PV modules of 30 years is used [51, 52]. Amorf-Si and CIGS are thin film technologies, with a total market share of about 8% in 2015 [49]. Thin film technologies can be very cost effective to produce [48, 53], and have a range of possibilities due to lower weight and higher flexibility in size and form compared to Multi-Si PV technology [6]. Thin film technologies have lower conversion efficiencies, as indicated in Table 2, but require fewer raw materials and have less embodied energy, as indicated in Table 1 and 2 [52]. However, depletion of raw materials for thin film technologies might become a barrier for deployment and cost reduction [53]. Among the thin film technologies, Amorf-Si is currently very popular [50]. Besides Amorf-Si, CIGS is seen as a promising thin film technology due to higher efficiencies while maintaining the above mentioned advantages [48].

Concerning the three technologies covered in this study, Table 1 shows the list of materials, metals and elements covered in this study, based on Ancitil et al [54]. This selection is based on the materials in PV modules that have currently a potential to be recycled [54]. Moreover, table 1 shows the availability of the selected materials, metals and elements in ocean water, based on Bardi [43], Turekian [55], Chow et al [56], R. Rovers et al [45], and V. Rovers et al [57].

Table 1. List of materials, metals and elements of the different PV technologies investigated in this study and their availability in ocean water.

Material	Multi-Si (g/m ²)	Amorf-Si (g/m ²)	CIGS (g/m ²)	Concentration in ocean water (ppm)	Amount of ocean water necessary for 1 kg (tons ocean water) ¹	Reference
Glass	8.90E+03			2.90E+00	3.45E+02	Turekian
Aluminium	1.35E+00		1.35E+00	1.00E-03	1.00E+06	Bardi, Turekian
Silicon	1.83E+02	2.28E+02		2.90E+00	3.45E+02	Turekian
Titanium	1.40E-01			1.00E-03	1.00E+06	Bardi, Turekian
Palladium	3.00E-03			3.00E-05	3.33E+07	Bardi
Silver	2.10E-01	5.30E-01		2.80E-04	3.57E+06	Turekian
Magnesium	7.00E-02			1.29E+03	7.80E-01	Bardi, Turekian
Zink		9.00E-01	4.50E-01	5.00E-03	2.00E+05	Bardi, Turekian
Amorphous silicon		9.00E-02		2.90E+00	3.45E+02	Turekian
Molybdenum			4.11E+00	1.00E-02	1.00E+05	Bardi, Turekian
Copper			1.19E+00	9.00E-04	1.11E+06	Bardi, Turekian
Indium			2.35E+00	4.00E-03	2.50E+05	Chow
Gallium			1.31E+00	3.00E-05	3.33E+07	Turekian
Selenide			2.96E+00	9.00E-04	1.11E+06	Turekian

¹ Based on Rovers [45, 57].

Concerning the three technologies covered in this study, Table 2 shows the energy characteristics per m² of different PV technologies investigated in this study and Table 3 shows the embodied land data per m² of different PV technologies investigated in this study, based on data from the Ecoinvent database accessed through SimaPro [58-60].

Table 2. Energy characteristics per m² of different PV technologies investigated in this study.

PV technology	STC power (Wp/m ²) ¹	Degradation (%/yr.) ²	EE extraction (MJ/m ²) ²	EE manufacturing (MJ/m ²) ²	EE construction (MJ/m ²) ²	EE reuse (MJ/m ²) ²	EE recycle (MJ/m ²) ²	EE circulation (MJ/m ²) ³
Amorf-Si	86	0.95%	13	1,060	178	178	1,060	1.75E+07
Multi-Si	147	0.59%	600	1,488	13	13	1,488	4.45E+07
CIGS	106	0.02%	148	1,220	13	13	1,220	4.13E+08

¹ Based on product data sheets [61-63].

² Based on de Wild-Scholten [64].

³ To filter 1 ton of ocean water, an amount of 2.5 kWh is needed [43].

Table 3. Embodied land (EL) characteristics per m² of different PV technologies investigated in this study.

PV technology	EL extraction (m ² ·a)	EL manufacturing (m ² ·a)	EL construction (m ² ·a)	EL reuse(m ² ·a)	EL recycle (m ² ·a)	EL circulation (m ² ·a)
Amorf-Si	3.8	0.033	n.a. ¹	n.a. ¹	0.033	n.a. ²
Multi-Si	12.7	0.033	n.a. ¹	n.a. ¹	0.033	n.a. ²
CIGS	5.2	0.033	n.a. ¹	n.a. ¹	0.033	n.a. ²

¹ In the case of BIPV and BAPV, no additional land is embodied in the construction and reuse phase. In the case of freestanding PV, the additional embodied land necessary for the installation placement should be included.

² In the investigated ocean route, no additional land is embodied due to temporary ocean surface occupation by vessels. In the case of other circulation routes, additional embodied land should be included if applicable.

2.2.2 Air gap height and materialization

To carry out the assessment, this study covers two ventilation possibilities: no ventilation and a 130 mm airgap enabling natural ventilation, based on previous research in which the effect of ventilation on electrical performance of PV was investigated [46, 65-67]. The 130 mm airgap is realised using an aluminium or bamboo carrying structure.

In current PV systems applied on buildings, aluminium is widely used as a carrying structure. However, aluminium is an energy intensive material and renewable materials might provide more sustainable solutions. An investigated renewable alternative is based on bamboo; Strand Woven Bamboo of the 5th Generation (SWB5G). In SWB5G production, 90% of the bamboo forest is usable which results in low environmental impacts. However, the resin used in SWB5G, Phenol-Formaldehyde (PF), is at the moment made out of crude oil with collateral environmental impact. In this study, PF is replaced by a bio-based variant which is expected to enter the market in the near future [68], resulting in a bamboo composite made out of 100% re-growable materials.



Figure 4. Strand Woven Bamboo of the 5th Generation (SWB5G).

In the investigated ventilated configurations A and B, illustrated in Fig. 5, 1 kg/m² of aluminium girders is needed for the supporting structure or 12 kg/m² of bamboo girders, in combination with 1.9 kg/m² Ethylene Propylene Diene Methylene (EPDM) roofing material per 1 m² BIPV rooftop. These amounts are based on the realised BIPV field test [46], without material optimisation. All connecting and/or supporting components, such as tape, bolts, screws, etc., are left out of the scope of this assessment.

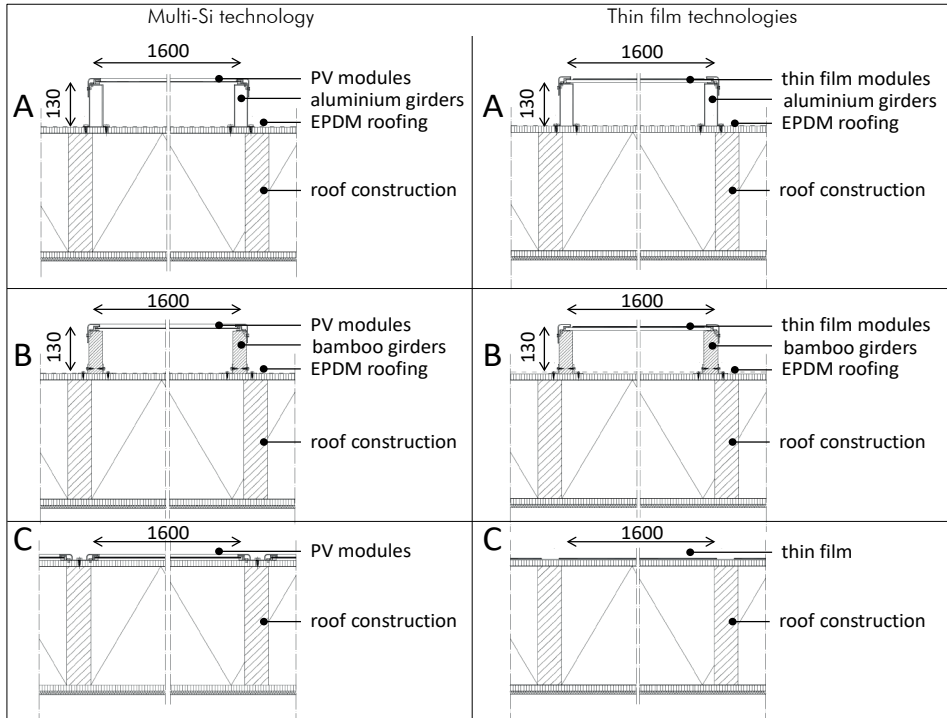

Figure 5. Horizontal sections of the Multi-Si and thin film (Amorf-Si and CIGS) BIPV rooftop configurations under investigation in this study; ventilated with an aluminium carrying structure (A), ventilated with a bamboo carrying structure (B), and non-ventilated (C). All dimensions in mm.

The embodied energy data and the embodied land data of the investigated rooftop components are based on the Ecoinvent database accessed through SimaPro [58, 59], and the data on bamboo is based on research conducted by Houben et al [68].

Table 4. Embodied energy (EE) characteristics of different materials investigated in this study per m² BIPV rooftop.

Materials	EE extraction (MJ/m ²)	EE manufacturing (MJ/m ²)	EE construction (MJ/m ²) ¹	EE reuse(MJ/m ²)	EE recycle (MJ/m ²)	EE circulation (MJ/m ²)
Aluminium	0.31 ²	184.7	7	7	9.2 ³	2.50E+06
Bamboo	188		8	8	n.a. ⁴	43 ⁵
EPDM	165		7	7	n.a. ⁶	n.a. ⁷

¹ According to Hong et al, the construction phase accounts for 4% of total embodied energy [69].

² To produce 1 kg of aluminium, 5.6 kg bauxite is necessary aluminium [70]; to extract 1 ton of bauxite, 54.9 MJ is necessary [71].

³ According to Efthymiou, et al, aluminium recycling requests 5% of the energy needed for primary manufacturing [72].

⁴ Due to the hybrid structure of the material, SWB5G cannot be recycled.

⁵ The circulation route for bamboo is based on chipping [73], and using the chips as nutrients in the production area of new bamboo.

⁶ EPDM cannot be recycled, only down-cycled.

⁷ EPDM consists of ethylene and propylene, which are gases at room temperature and atmospheric pressure, of which the circulation route is outside the scope of this study.

Table 5. Embodied land (EL) characteristics of different materials investigated in this study per m² BIPV rooftop.

Materials	EL extraction (m ² ·a)	EL manufacturing (m ² ·a)	EL construction (m ² ·a)	EL reuse(m ² ·a)	EL recycle (m ² ·a)	EL circulation (m ² ·a)
Aluminium	0.85	n.a. ¹	n.a. ²	n.a. ²	n.a. ¹	n.a. ³
Bamboo	15.44	n.a. ¹	n.a. ²	n.a. ²	n.a. ¹	0
EPDM	1.18	n.a. ¹	n.a. ²	n.a. ²	n.a. ¹	n.a. ³

¹ Land use is not included as an impact category in consulted LCA studies, due to limited availability of data [70, 74].

² In the case of BIPV and BAPV, no additional land is embodied in the construction and reuse phase. In the case of freestanding PV, additional embodied land should be included.

³ In the investigated ocean route, no additional land is embodied due to ocean surface occupation. In the case of other circulation routes, additional embodied land should be included if applicable.

2.2.3 PV output

To carry out the assessment, the yearly PV output, expressed in kWh, has to be defined. In this study, the electrical output is calculated in the simulation software System Advisory Model (SAM) [75]. SAM offers the possibility to select the appropriate meteorological data for the location, the appropriate PV installation specifications and offers different integration levels affecting backside ventilation, and thus performance [75].

2.2.4 PV array size

To carry out the assessment, the PV array size, expressed in kWp and m², has to be defined. In this study, the PV array size is 9.6 m² based on the described BIPV rooftop component described in section 2.1.

2.3 Impact assessment equations

To carry out the assessment, the Life Cycle Inventory (LCI) presented in Fig. 6. has been developed, covering all process steps relevant for a circular assessment, elaborated on previous research [76]. Phases included in this study are highlighted in grey in Fig. 6.

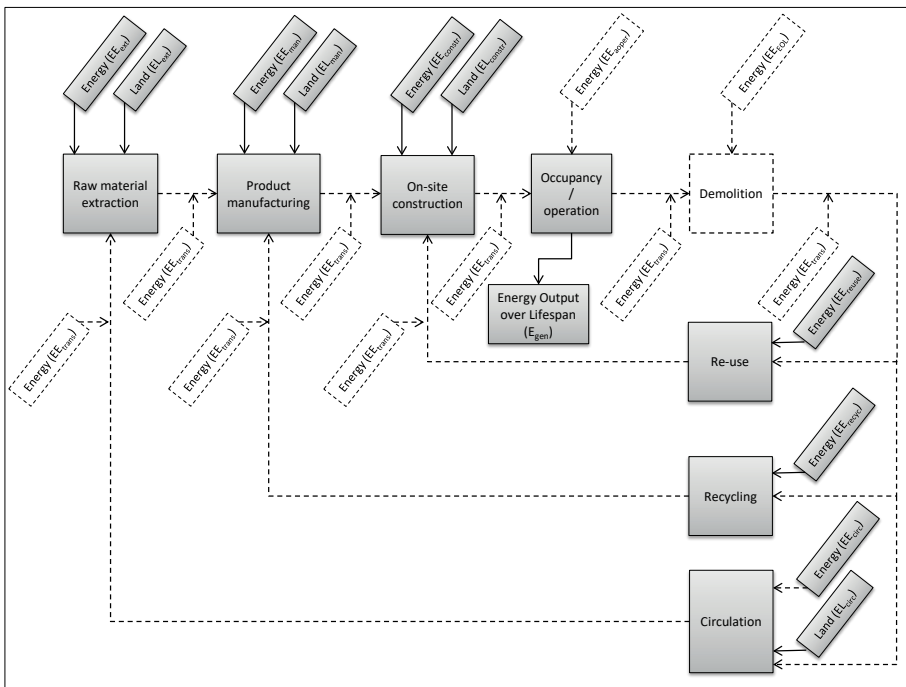

Figure 6. The different Life Cycle Inventory (LCI) phases applied in this study.

Consequently, the following equations are applied to calculate Embodied Land:

$$EE_{tot} = EE_{ext} + EE_{man} + EE_{constr} + EE_{reuse} + EE_{recyc} + EE_{circ} \quad (1)$$

- EE_{tot} = Embodied Energy total
- EE_{ext} = Embodied Energy raw material extraction (mining, forestry)
- EE_{man} = Embodied Energy product manufacturing (production process)
- EE_{constr} = Embodied Energy on-site construction (construction)
- EE_{reuse} = Embodied Energy reuse (re-construction)
- EE_{recyc} = Embodied Energy recycling (production process)
- EE_{circ} = Embodied Energy circulation (recovery materials ocean water route)

$$EL_{tot} = EL_{ext} + EL_{man} + EL_{constr} + EL_{reuse} + EL_{recyc} + EL_{circ} + EL_{EE} \quad (2)$$

- EL_{tot} = Embodied Land total
- EL_{ext} = Embodied Land raw material extraction (mining, forestry land occupation)
- EL_{man} = Embodied Land product manufacturing (allocation factory land occupation)
- EL_{constr} = Embodied Land on-site construction (building footprint, site)
- EL_{reuse} = Embodied Land reuse
- EL_{recyc} = Embodied Land recycling (allocation factory land occupation)
- EL_{circ} = Embodied Land circulation
- EL_{EE} = Embodied Land embodied energy, in which:

$$EL_{EE} = EE_{tot} * f \quad (3)$$

f = conversion factor (distilled from the amount of m^2 necessary to generate the embodied energy with the given installation), based on E_{gen} and array size (in m^2):

$$f = E_{gen} / \text{array size} \quad (4)$$

E_{gen} = calculated or measured produced energy by the BIPV installation over its lifespan.

3. Application

The BIPV field test realised in the Real Life Learning Lab 'The District of Tomorrow' (TDoT) in Heerlen, the Netherlands [46], has been selected for application of the equations in this study. The geographic location of TDoT is 50°49'47" latitude, 6°1'2" longitude and 183 m altitude. Weather data are based on the measurements of the

meteorological station Beek, approx. 30 km west of the field test [77-79]. The BIPV field test has a roof pitch of 35° and South orientation.

Table 6 shows the electrical performance of the different BIPV configurations and technologies per 1 m² on this location, calculated in SAM [75].

Table 6. Electrical PV performance per 1 m² of the different BIPV configurations.

PV technology	STC power (kWp)	Maximum recycling rate (%) ¹	Calculated output non-ventilated configuration (kWh·a)	Calculated output calculated ventilated configuration (kWh·a)
Multi-Si	0.15	86.5	127	130
Amorf-Si	0.09	86.4	80	81
CIGS	0.11	94.9	94	97

¹ Based on Anctil et al [54].

Table 7 shows the environmental impact expressed in EL per 1 m², calculated with the equations given in section 2.3, of the different BIPV rooftop configurations with current maximum recycling rates.

Table 7. Embodied Land per 1 m² of the different BIPV configurations with current maximum recycling percentages.

PV technology	Recycling (%)	Circulation (%)	EL non-ventilated configuration (m ² ·a)	EL aluminium ventilated configuration (m ² ·a)	EL bamboo ventilated configuration (m ² ·a)
Multi-Si	86.5	13.5	5.84E+03	6.02E+03	5.71E+03
Amorf-Si	86.4	13.6	3.67E+03	4.11E+03	3.61E+03
CIGS	94.9	5.1	2.76E+04	2.70E+04	2.68E+04

With current maximum recycling rates and the selected circulation route, the BIPV configuration with lowest environmental impact is the bamboo ventilated Amorf-Si variant with 3.67E+03 m²·a impact. With a lifetime of 30 years, this would result in an environmental impact of 123 m² per 1 m² BIPV rooftop.

To investigate the possibility to lower the environmental impact, table 8 shows the EL with a hypothetical 100% recycling.

Table 8. Embodied Land per m² of the different BIPV configurations with 100% recycling.

PV technology	Recycling (%)	EL non-ventilated configuration (m ² ·a)	EL aluminium ventilated configuration (m ² ·a)	EL bamboo ventilated configuration (m ² ·a)
Multi-Si	100	16.3	17.3	31.9
Amorf-Si	100	7.44	8.52	23.1
CIGS	100	8.65	9.66	24.3

With a recycling rate of 100%, the BIPV configuration with lowest environmental impact is the non-ventilated Amorf-Si variant, with approximately 7.44 m²·a impact. Reusing 50% of the PV modules and the aluminium/bamboo structure would further lower the environmental impact of this configuration to 6.74 m²·a, not taking into account the possible malfunctioning of PV modules.

4. Discussion

This paper presents the LCI and equations to assess the environmental impact related to carrying capacity, expressed in the non-weighted indicator Embodied Land.

As the available data lacks a certain level of accuracy and different datasets show large differences, a next step is to obtain more accurate numbers to improve the robustness of results. Future work should be focused on refining datasets, background process impacts, and the system's boundary conditions [2, 23].

This study is focused on environmental assessment with a single non-weighted environmental impact indicator; potential impacts on human health, air cycle and water cycle of the materials and chemicals used in the configurations are outside the scope of this research. In future research other impact indicators have to be addressed. This study is focused on impacts of the first order of a selection of configurations, and production of capital goods (machines, buildings, etc.) are not included [19]. Moreover, effect on grid, storage and a rebound effect not taken into account [51, 80]. The three selected BIPV configurations are indicative to demonstrate the application of the equations and show that their environmental impact exceeds carrying capacity. In future research, more BIPV configurations, PV technologies, electricity connections and material optimisation and alternatives should be included.

Considering the circulation route, energy consumption is based on extraction of low concentration resources from ocean water, which is a very energy intensive route. Other routes, other processes and a combination with other processes are therefore to be investigated in future research such as extending resource cycles of non-renewable resources by re-using, recycling or recirculating on earlier phases (e.g. river filtering), resulting in longer time span of material application and consequently longer time periods involved in the circulation phase. Reusing and recycling cannot be seen as replacement of the circulation, but as an extension of environmental impact compensation. In future studies, the assessment should cover later phases as well. In the selected circulation route, impacts of materials other than ores are negligible due to the embodied energy necessary for recuperation from ocean water as baseline route.

Large amounts of waste are and will be generated in the PV industry at the end-of-life, but there is little motivation for a complete re-use and/or recycling [54]. In the 80% CO₂ scenario of the EU, 63 million PV modules would be installed in the Neth-

erlands [81], which all would have to be replaced in the shorter or longer run, resulting in an annual replacement market in the second part of the 21st century of 1.5-2.5 million PV modules.

This study indicates that a circular environmental impact calculation in a non-weighted single indicator in the complex technical and physical situation that it tries to take into account is highly vulnerable to developments in all these fields, therefore results are difficult to extrapolate into the future [2, 51, 82]. The space and time scales necessary for impact assessment relate to the biosphere as a whole, and, collaterally, inevitably this is characterized by large uncertainties [83].

5. Conclusions

In this study the equations for carrying capacity environmental assessment have been developed and applied on different BIPV rooftop configurations. The equations express the environmental impact in a circular, non-weighted indicator, Embodied Land, and the results create insight in the balance between productive capacity and consumption, and overcomes the discussion on exhaustion and depletion of resources.

The first relevant outcomes of this study are the equations to calculate environmental impact related to carrying capacity, which can be applied in a stand-alone environmental impact calculation framework, or can be embedded in integral environmental impact calculation tools.

The second relevant outcome is the limited comparison between different BIPV configurations, consisting of three PV technologies; Amorf-Si, Multi-Si and CIGS, and three integration variations; non-ventilated, ventilated with an aluminium construction and ventilation with a bamboo construction. Based on this comparison, the Amorf-Si bamboo ventilated BIPV rooftop configuration shows the lowest environmental impact with $3.67E+03 \text{ m}^2\cdot\text{a}$, given the investigated BIPV configurations. This environmental impact exceeds carrying capacity with current maximum recycling percentages. Reusing and recycling are successful routes for extending lifespan of material application with less environmental impact compared to the circulation route, emphasizing the necessity of closing loops of non-renewable resources. Moreover, replacing non-renewable materials and resources such as applied in SWB5G and EPDM will positively affect the environmental impact. With 100% recycling, the Amorf-Si non-ventilated BIPV rooftop configuration shows the lowest environmental impact with $7.44 \text{ m}^2\cdot\text{a}$, given the investigated BIPV configurations.

This study contributes to a holistic performance rating for PV application in the built environment and provides guidance for PV developers, installers and construction industry professionals to develop BIPV configurations with lowest environmental impact.

6. Acknowledgement

This research was partially funded by the Dutch Organisation for Scientific Research (NWO), project number 023.001.198, and by the Foundation Innovation Alliance (SIA), project number PRO-2-015 IMDEP and IMDEP Top-up. The author would like to thank all participants of these projects, Bert Blocken and Marie Nehasilová for supporting this study.

References

1. Mellino, S., E. Buonocore, and S. Ulgiati, *The worth of land use: A GIS–energy evaluation of natural and human-made capital*. *Science of The Total Environment*, 2015. 506–507(0): p. 137-148.
2. Habert, G., et al., *Development of a depletion indicator for natural resources used in concrete*. *Resources, Conservation and Recycling*, 2010. 54(6): p. 364-376.
3. European Commission, *Directive 2012/27/EU of the European Parliament and of the Council of 25 October 2012*. 2012.
4. Dixit, M.K., et al., *Need for an embodied energy measurement protocol for buildings: A review paper*. *Renewable and Sustainable Energy Reviews*, 2012. 16(6): p. 3730-3743.
5. CESBA, *Initiative Policy Paper - Towards a Common Sustainable Building Assessment in Europe*. 2014.
6. Chatzisideris, M.D., et al., *Ecodesign perspectives of thin-film photovoltaic technologies: A review of life cycle assessment studies*. *Solar Energy Materials and Solar Cells*.
7. European Commission, *Roadmap to a Resource Efficient Europe*. 2011.
8. European Commission, *Directive 2010/31/EU of the European Parliament and of the Council of 19 May 2010 on the energy performance of buildings (recast)*. 2010.
9. Boermans, T., M. Offermann, and R. de Vos, *A heating & cooling strategy for the European building sector until 2050*. 2015.
10. Ritzen, M.J., et al., *Environmental impact evaluation of energy saving and energy generation: Case study for two Dutch dwelling types*. *Building and Environment*, 2016. 108: p. 73-84.
11. Ritzen, M.J., Z.A.E.P. Vroon, and C.P.W. Geurts, *Building Integrated Photovoltaics*, in *Photovoltaic Solar Energy: From Fundamentals to Applications*, A. Reinders, et al., Editors. 2017, Wiley. p. 688.
12. Henemann, A., *BIPV: Built-in solar energy*. *Renewable Energy Focus*, 2008. 9(6, Supplement): p. 14-19.
13. Cerón, I., E. Caamaño-Martín, and F.J. Neila, *'State-of-the-art' of building integrated photovoltaic products*. *Renewable Energy*, 2013. 58(0): p. 127-133.
14. Quesada, G., et al., *A comprehensive review of solar facades. Opaque solar facades*. *Renewable and Sustainable Energy Reviews*, 2012. 16(5): p. 2820-2832.
15. Azadian, F. and M.A.M. Radzi, *A general approach toward building integrated photovoltaic systems and its implementation barriers: A review*. *Renewable and Sustainable Energy Reviews*, 2013. 22(0): p. 527-538.
16. Verberne, G., et al. *BIPV Products for facades and roofs: a market analysis*. in *PVSEC*. 2014. Amsterdam, the Netherlands.
17. Baljit, S.S.S., H.-Y. Chan, and K. Sopian, *Review of building integrated applications of photovoltaic and solar thermal systems*. *Journal of Cleaner Production*, 2016. 137: p. 677-689.
18. Maturi, L., et al. *Building skin as electricity source: the prototype of a wooden BIPV facade component*. in *26th European Photovoltaic Solar Energy Conference*. 2011. Hamburg, Germany.
19. Ministry of Housing, S.P.a.t.E., *Eco-indicator 99, A damage orientated method for Life Cycle Impact Assessment*. 2000, Ministry of Housing, Spatial Planning and the Environment.
20. Shao, L., Z. Wu, and G.Q. Chen, *Exergy based ecological footprint accounting for China*. *Ecological Modelling*, (0).
21. Bruckner, M., et al., *Materials embodied in international trade – Global material extraction and consumption between 1995 and 2005*. *Global Environmental Change*, 2012. 22(3): p. 568–576.
22. Daily, G.C. and P.R. Ehrlich, *Population, Sustainability, and Earth's Carrying Capacity: A framework for estimating population sizes and lifestyles that could be sustained without undermining future generations*. *BioScience*, 1992. 42(November): p. 761-771.
23. Anctil, A. and V. Fthenakis, *Third generation photovoltaics - Life Cycle Assessment of Organic Photovoltaics*, ed. V.M. Fthenakis. 2012: InTech. 244.
24. Milà i Canals, L., et al., *Key Elements in a Framework for Land Use Impact Assessment Within LCA (11 pp)*. *The International Journal of Life Cycle Assessment*, 2007. 12(1): p. 5-15.

25. Rovers, R., et al., *Space-time of solar radiation as guiding principle for energy and materials choices*, in *World Renewable Energy Congress 2011*. 2011: Linköping, Sweden.
26. Silvestre, J.D., J. de Brito, and M.D. Pinheiro, *Environmental impacts and benefits of the end-of-life of building materials – calculation rules, results and contribution to a “cradle to cradle” life cycle*. *Journal of Cleaner Production*, (0).
27. van Dijk, S., M. Tenpierik, and A. van den Dobbelsteen, *Continuing the building's cycles: A literature review and analysis of current systems theories in comparison with the theory of Cradle to Cradle*. *Resources, Conservation and Recycling*, 2014. 82(0): p. 21-34.
28. Moncaster, A.M. and K.E. Symons, *A method and tool for 'cradle to grave' embodied carbon and energy impacts of UK buildings in compliance with the new TC350 standards*. *Energy and Buildings*, 2013. 66(0): p. 514-523.
29. Srinivasan, R.S., et al. *Building Envelope Optimisation Using Energy Analysis*. in *12th Conference of International Building Performance Simulation Association*. 2011. Sydney, Australia.
30. Densley Tingley, D. and B. Davison, *Developing an LCA methodology to account for the environmental benefits of design for deconstruction*. *Building and Environment*, 2012. 57(0): p. 387-395.
31. Hernandez, P. and P. Kenny, *Development of a methodology for life cycle building energy ratings*. *Energy Policy*, 2011. 39(6): p. 3779-3788.
32. Häkkinen, T.e., *Sustainability and performance assessment and benchmarking of buildings - Final report*. 2012, VTT: Espoo.
33. Zhao, S., Z. Li, and W. Li, *A modified method of ecological footprint calculation and its application*. *Ecological Modelling*, 2005. 185(1): p. 65-75.
34. Romero, J.C. and P. Linares, *Exergy as a global energy sustainability indicator. A review of the state of the art*. *Renewable and Sustainable Energy Reviews*, 2014. 33(0): p. 427-442.
35. Bastianoni, S., et al., *Exergy as a function of exergy*. *Energy*, 2007. 32(7): p. 1158-1162.
36. Rovers, R., *Exergy is not only about energy*. 2011.
37. Fiksel, J., *A systems view of sustainability: The triple value model*. *Environmental Development*, 2012. 2(0): p. 138-141.
38. Commission, E., *DIRECTIVE 2009/125/EC OF THE EUROPEAN PARLIAMENT AND OF THE COUNCIL - establishing a framework for the setting of ecodesign requirements for energy-related products (recast)*. 2009.
39. ISO, *ISO 14044:2006(en) Environmental management — Life cycle assessment — Requirements and guidelines*. 2006.
40. Malmqvist, T., et al., *Life cycle assessment in buildings: The ENSLIC simplified method and guidelines*. *Energy*, 2011. 36(4): p. 1900-1907.
41. Crawford, R.H., *Life cycle assessment in the built environment*. 2011, New York, USA: Spon Press.
42. Ritzen, M.J., *IEA PVPS Task 15 workplan*. 2015, IEA.
43. Bardi, U., *Extracting Minerals from Seawater: An Energy Analysis*. *Sustainability*, 2010. 2: p. 980-992.
44. European Commission, *Blue Growth - opportunities for marine and maritime sustainable growth 2012*.
45. Rovers, R., et al. *Closing Cycles: Circular Energy, the missing link*. in *5th International Exergy, Life Cycle Assessment, and Sustainability Workshop & Symposium (ELCAS5)*. 2017. Nisyros, Greece.
46. Ritzen, M.J., et al., *Comparative performance assessment of a non-ventilated and ventilated BIPV rooftop configurations in the Netherlands*. *Solar Energy*, 2017. 146: p. 389-400.
47. Ritzen, M.G., Leo; Rovers, Ronald; Geurts, Chris; Vroon, Zeger; Sigwarth, Stefan. *Insulation versus installation - an exploration towards maximization*. in *SB 13 Implementing sustainability - barriers and chances*. 2013. Munich: Fraunhofer IRB.Verlag.
48. Theelen, M., *Degradation of CIGS solar cells*, in *Electrical Engineering*. 2015, Technical University: Delft.
49. Fraunhofer Institute for Solar Energy, I., *Photovoltaics report*. 2016.
50. Tyagi, V.V., et al., *Progress in solar PV technology: Research and achievement*. *Renewable and Sustainable Energy Reviews*, 2013. 20(0): p. 443-461.

51. Raugei, M., P. Fullana-i-Palmer, and V. Fthenakis, *The energy return on energy investment (EROI) of photovoltaics: Methodology and comparisons with fossil fuel life cycles*. *Energy Policy*, 2012. 45(0): p. 576-582.
52. Peng, J., L. Lu, and H. Yang, *Review on life cycle assessment of energy payback and greenhouse gas emission of solar photovoltaic systems*. *Renewable and Sustainable Energy Reviews*, 2013. 19: p. 255-274.
53. Candelise, C., J.F. Speirs, and R.J.K. Gross, *Materials availability for thin film (TF) PV technologies development: A real concern?* *Renewable and Sustainable Energy Reviews*, 2011. 15(9): p. 4972-4981.
54. Anttil, A. and V.M. Fthenakis, *Critical metals in strategic photovoltaic technologies: abundance versus recyclability*. *PROGRESS IN PHOTOVOLTAICS: RESEARCH AND APPLICATIONS*, 2012.
55. Turekian, K.K., *Oceans*. 1968: Prentice-Hall.
56. Chow, T.J. and C.B. Snyder, *Indium content of sea water*. *Earth and Planetary Science Letters*, 1969. 7(3): p. 221-223.
57. Rovers, V., et al., *Maxergy, duurzaamheidsberekening op basis van landgebruik*. 2011, RiBuiT / Zuyd University of Applied Sciences.
58. Frischknecht, R. and N. Jungbluth, *Ecoinvent data v2.0 overview and methodology*. 2007.
59. consultancy, P. *Simapro website*. 2014 [cited 2014 18-12]; Available from: <http://www.pre-sustainability.com/simapro>.
60. Jungbluth, N., et al., *Life Cycle Inventories of Photovoltaics*. 2012, ESU services.
61. Hyet Solar, *product data sheet* 2016.
62. Solland Solar, *product data sheet*. 2010.
63. Global Solar, *product data sheet*. 2016.
64. de Wild-Scholten, M.J., *Energy payback time and carbon footprint of commercial photovoltaic systems*. *Solar Energy Materials and Solar Cells*, 2013. 119: p. 296-305.
65. Ritzen, M., et al., *Comparative performance assessment of four BIPV roof solutions in the Netherlands*, in *ICBest 2014*. 2014: Aachen.
66. Ritzen, M., et al. *Development, realization and monitoring of 2 BIPV field tests in the Netherlands*. in *29th European Photovoltaic Solar Energy Conference and Exhibition*. 2014. Amsterdam, the Netherlands.
67. Maturi, L., et al., *Experimental investigation of a low cost passive strategy to improve the performance of Building Integrated Photovoltaic systems*. *Solar Energy*, 2015. 111(0): p. 288-296.
68. Houben, J., *MAXergy berekeningen SWB5G t.o.v.hout, staal en aluminium*. 2016, Zuyd University of Applied Sciences: Heerlen.
69. Hong, T., et al., *Assessment Model for Energy Consumption and Greenhouse Gas Emissions during Building Construction*. *Journal of Management in Engineering*, 2014. 30((2)): p. 226-235.
70. Institute, I.A., *Environmental Metrics Report*. 2014, International Aluminium Institute: London, UK.
71. Norgate, T. and N. Haque, *Energy and greenhouse gas impacts of mining and mineral processing operations*. *Journal of Cleaner Production*, 2010. 18(3): p. 266-274.
72. Efthymiou, E., Ö.N. Cöcen, and S.R. Ermolli, *Sustainable Aluminium Systems*. *Sustainability*, 2010. 2(9): p. 3100.
73. Hellstrom, L., *On the wood chipping process - A study on basic mechanisms in order to optimize chip properties for pulping*, in *Department of Natural Sciences, Engineering and Mathematics*. 2010, Mid Sweden University: Sundsvall, Sweden.
74. Vos, R.B., *Managing the sustainability of rubber products: Examining four reclaiming technologies for EPDM roof sheets*, in *Urban environmental management - Sustainable supply chain management*. 2012, Wageningen University: Wageningen.
75. NREL, SAM. 2014; PV system advisory model]. Available from: <https://sam.nrel.gov/>.
76. Ritzen, M., et al., *Environmental impact comparison of a ventilated and a non-ventilated building-integrated photovoltaic rooftop design in the Netherlands: Electricity output, energy payback time, and land claim*. under review, 2017.

77. KNMI. *Maastricht, langjarig gemiddelden, tijdvak 1981-2010*. 2013; Available from: http://www.klimaatatlas.nl/tabel/stationsdata/klimtab_8110_380.pdf.
78. ASHRAE, *International Weather for Energy Calculations (IWEC Weather Files) Users Manual and CD-ROM*, ASHRAE, Editor. 2001.
79. ASHRAE, *typical weather data Beek, NL*, ASHRAE, Editor. 2014.
80. Bourrelle, J.S., *Zero energy buildings and the rebound effect: A solution to the paradox of energy efficiency?* Energy and Buildings, 2014. 84(0): p. 633-640.
81. Roelofsen, O., A. de Pee, and E. Speelman, *Accelerating the energy transition: cost or opportunity?*, McKinsey&Company, Editor. 2016, McKinsey&Company: Amsterdam.
82. Frischknecht, R., R. Itten, and F. Wyss, *Life Cycle Assessment of Future Photovoltaic Electricity Production from Residential-scale Systems Operated in Europe*. 2015, IEA PVPS Task 12.
83. Brown, M.T., M. Raugei, and S. Ulgiati, *On boundaries and 'investments' in Energy Synthesis and LCA: A case study on thermal vs. photovoltaic electricity*. Ecological Indicators, 2012. 15(1): p. 227-235.

Chapter 9

Conclusions

The aim of this thesis was to develop a framework for carrying capacity based environmental assessment of Building Integrated Photovoltaics (BIPV). The framework covers the environmental impact of (operating and embodied) energy and materials of BIPV, and expresses the environmental impact in the claim on carrying capacity. The framework is based on the Life Cycle Assessment (LCA) method and consists of a circular Life Cycle Inventory (LCI) and collateral assessment equations.

To realize this aim, experimental research in a BIPV field test was conducted and numerical modelling of environmental assessment was performed, addressing the following research questions:

1. What are building environmental impact assessment tools currently applied in practice, and which indicator is applicable to express environmental impact in the claim on carrying capacity?
2. What is the effect of expressing the environmental impact in the indicator embodied energy and claim on carrying capacity of different building envelope renovation configurations?
3. What is the effect of different BIPV configurations on electrical performance and lifespan of photovoltaics (PV) modules, based on simulation and measurements in a field test?
4. What is the effect of expressing the environmental impact in the indicator energy payback time and claim on carrying capacity of the electrical performance and material consumption of different BIPV configuration?
5. How can the complete life cycle carrying capacity based environmental impact of BIPV configurations be assessed to compare different BIPV configurations?
6. What is the BIPV configuration with lowest carrying capacity based environmental impact, given a selection of technologies and integration possibilities for the realized BIPV field test?

In this conclusion chapter, the conclusions of the different chapters in this thesis are presented, resulting in general conclusions, reflections and recommendations.

Chapter 2 addresses the first research question in which the field of environmental impact assessment tools applied in the built environment is investigated:

What are building environmental impact assessment tools currently applied in practice, and which indicator is applicable to express environmental impact in the claim on carrying capacity?

Currently applied building environmental impact assessment tools either focus on one aspect, such as operational energy, and result in a quantitative outcome such as MJ/m², or these tools combine different aspects, such as energy and materials, through a weighted system and result in a quantitative outcome, such as 'excellent'. Both outcomes are not related to the carrying capacity of a system. A carrying capacity based environmental impact assessment approach, MAXergy, generates insight in the material and energy related carrying capacity based environmental im-

part of a building by combining these two aspects in the single non-weighted indicator 'Embodied Land (EL)' expressed in $\text{m}^2 \cdot \text{a}$. By using the MAXergy approach, the environmental impact of a building is related to less abstract terms such as 'Greenhouse gasses' (GHG) and 'Mega Joules' (MJ) and more to the physical identifiable term square meter yearly land occupation ($\text{m}^2 \cdot \text{a}$).

The challenge is to realize Zero Energy Buildings (ZEBs) with minimal carrying capacity based environmental impact, and this chapter shows the need to assess the environmental impact of the built environment from a holistic viewpoint, taking both energy and materials into account covering the complete life cycle. In the case of a ZEB, material related environmental impact becomes the determining factor with respect to the carrying capacity based environmental impact, which can be assessed in the MAXergy approach. This study shows that the amount and the choice of materials determine the environmental impact. To investigate the results of expressing environmental impact in the claim on carrying capacity a number of different building envelope configurations is assessed and optimized from a carrying capacity based view, reaching the ZEB level, presented in chapter 3 and 4, addressing the second research question:

What is the effect of expressing the environmental impact in the indicator embodied energy and claim on carrying capacity of different building envelope renovation configurations?

Considering the investigated office façades and investigated dwelling building envelopes, operational energy efficiency improvements collaterally show an increase of embodied energy of 1.2 GJ/m^2 floor area for the office façade, 3.4 GJ/m^2 floor area for the terraced dwelling type, and 5.2 GJ/m^2 floor area for the detached dwelling type. The embodied energy accounts for approximately 15% of total energy consumption over the lifespan of all investigated case studies. To regenerate the energy embodied in materials an additional 3.4 and 7.3 m^2 of PV modules should be added to the dwelling types, resulting in Life Cycle Zero Energy Buildings (LC-ZEB).

Considering office façades, the case study presented in chapter 3 shows that the lowest environmental impact is created with a façade that is based on renewable materials and has an average U-value of $0.6 \text{ W/m}^2\text{K}$. Considering dwelling envelopes, the case studies presented in chapter 4 show that the lowest environmental impact is created with a building envelope that is based on renewable materials and has an average U-value of $0.29 \text{ W/m}^2\text{K}$. To reach ZEB level, 35 and 74.5 m^2 of PV modules are necessary for the terraced and detached dwelling type, respectively.

Considering office façade renovations, the case study presented in chapter 3 shows that the claim on carrying capacity is 5.4 m^2 over 30 years for one square meter selected south facing façade configuration. With a total of approximately 32 km^2 office facades in the Netherlands, $1.7\text{E}+02 \text{ km}^2$ land would be needed for the generation of materials for an office facade based on the investigated design.

Considering dwelling building envelope renovations, the case studies presented in chapter 4 show that the claim on carrying capacity is approximately $6.0\text{E}+03 \text{ m}^2$ over 50 years for the terraced dwelling type and $1.3\text{E}+04 \text{ m}^2$ over 50 years for the detached dwelling type. With a total of approximately 2.8 million terraced dwellings in the Netherlands, $1.7\text{E}+04 \text{ km}^2$ would be needed for the generation of materials for the ZEB renovation based on the investigated configuration, and with a total of approximately 1 million detached dwellings in the Netherlands, $1.3\text{E}+04 \text{ km}^2$ would be needed for the generation of materials for the ZEB renovation based on the investigated configuration.

These carrying capacity based environmental impact assessments show that the lowest environmental impact is reached with limited added insulation values and large PV systems, demonstrating the effect of applying a non-weighted joint assessment of materials and energy. These assessments illustrate that the current trend of increasing insulation values does not result in the lowest overall carrying capacity based environmental impact.

Of the $4.1\text{E}+04 \text{ km}^2$ available land area in the Netherlands, approximately 0.5% would be needed for the generation of materials for office façades, approximately 40% would be needed for the generation of materials for the terraced dwellings, and approximately 30% would be needed for the generation of materials for the detached dwellings. Consequently, less than 30% would be left for all other activities, such as food production and for the generation of materials necessary for the renovation and realization of other buildings, showing the current exceeding of carrying capacity. Building envelope configurations with lower insulation values and large PV systems contribute to reaching ZEB level while showing less carrying capacity based environmental impact than building envelope configurations with high insulation values and small PV systems. To investigate the effects of integration of PV in building envelope configurations, a building integrated PV field test has been designed, realized, monitored and dismantled, presented in chapter 6, addressing the third research question:

What is the effect of different BIPV configurations on electrical performance and lifespan of photovoltaics (PV) modules, based on simulation and measurements in a field test?

In this chapter, a BIPV rooftop field test with 24 multi-crystalline 60-cell MWT modules is presented with different levels of backside ventilation, ranging between non-ventilated to double mechanical ventilated. In the first year of monitoring, the simulated PV output difference between a ventilated and non-ventilated configuration is 3% and the measured difference is 15%. The ventilated segments show a similar behavior (6% difference) in PV energy output, but the non-ventilated segment shows a strong decrease of 86% in output after three years. Repetitive operating temperatures of 80°C occurred in the non-ventilated configuration and daily temperature amplitudes reached 60°C in the non-ventilated configuration. Moreover, in the natu-

ral ventilated and non-ventilated configuration there is a risk of condensation due to 100% relative humidity, which could lead to moisture in the building skin if PV panels would replace the roofing material. The average air velocity in the non-ventilated segment was 13% of the air velocity in the double mechanical ventilated segment.

The results obtained in this chapter show that the integrated PV modules have a lower performance and shorter lifespan than the non-integrated modules. Ventilation proves to be an effective way to prevent PV modules from accumulating heat with collateral negative effects on PV performance and lifespan. Placing mechanical ventilation outlets between roof and PV modules contributes to increased ventilation. While the electrical performance and lifespan of different BIPV configurations is presented in this chapter, environmental aspects of these BIPV configurations is not covered. In chapter 7, the environmental impact assessment is presented of these BIPV configurations, addressing the fourth research question:

What is the effect of expressing the environmental impact in the indicator energy payback time and claim on carrying capacity of the electrical performance and material consumption of different BIPV configuration?

To investigate the environmental impact of different BIPV configurations, the environmental impact of the field test described in chapter 6 has been assessed in the current situation and three future scenarios. Calculations indicate that the EPBT of the ventilated BIPV rooftop design (3.56 and 4.59 years, based on SimaPro and ICE, respectively) is 9 and 6% longer than the EPBT of the non-ventilated BIPV rooftop design (3.25 and 4.32 years, based on SimaPro and ICE, respectively). Calculations indicate that the claim on carrying capacity of an m^2 ventilated BIPV rooftop design (24.4 and 19.4 $\text{m}^2 \cdot \text{a}$, based on SimaPro and MAXergy, respectively) is 18 and 10% higher than the claim on carrying capacity of an m^2 non-ventilated BIPV rooftop design (20.0 and 17.4 $\text{m}^2 \cdot \text{a}$, based on SimaPro and MAXergy, respectively). The future scenarios indicate that due to higher module efficiencies, higher grid efficiencies and lower embodied energy in PV modules the EPBT can decrease with 28-37% in the optimal scenario, compared to the current situation and the claim on carrying capacity can decrease with 21-40% in the optimal scenario, compared to the current situation. In all scenarios, the non-ventilated BIPV design shows lower environmental impacts than the ventilated BIPV design. In this chapter, the environmental impact assessment is limited to the simulated BIPV configurations presented in chapter 6 and a limited life cycle inventory has been applied due to the limitations of the applied tools. The results in chapter 8 continue on the study presented in chapter 7 and presents a Life Cycle Inventory and collateral equations to assess the complete life cycle impact of BIPV configurations, addressing the fifth and sixth research question:

How can the complete life cycle carrying capacity based environmental impact of BIPV configurations be assessed to compare different BIPV configurations?

What is the BIPV configuration with lowest carrying capacity based environmental impact, given a selection of technologies and integration possibilities for the realized BIPV field test?

To answer these questions, carrying capacity based environmental assessment equations are presented and applied on different BIPV configurations. The application covers three different PV technologies; Amorf-Si, Multi-Si and CIGS, in three different BIPV rooftop configurations; non-ventilated, ventilated with an aluminium construction and ventilated with a bamboo construction. The application covers percentages of reusing, recycling and circulation for a circular assessment. Given the selected technologies and BIPV configurations in this study, the Amorf-Si bamboo ventilated BIPV rooftop configuration with current maximum recycling percentages shows the lowest environmental impact with $3.6E+03$ ($m^2 \cdot a$) in the selected case study per m^2 rooftop. The environmental impact of all configurations exceeds carrying capacity with current maximum recycling percentages. The environmental impact would further increase if the calculations would be based on the measurements of the Multi-Si BIPV configurations presented in chapter 6. Reusing and recycling are successful routes for extending cycles with less environmental impact in combination with a minimal portion in the circulation route, emphasizing the necessity of closing loops of non-renewable resources. To stay within the carrying capacity, reusing and recycling percentages have to be further improved of current PV technologies or non-renewable resources have to be eliminated or replaced by renewable resources. With 100% recycling, the Amorf-Si non-ventilated BIPV rooftop configuration shows the lowest environmental impact with $7.4E-01$ ($m^2 \cdot a$) in the selected case study.

General conclusion

The results of this thesis offer comprehensive insight in current applied environmental assessment tools and carrying capacity based environmental impact related to specific building envelope configurations for offices, existing dwellings and BIPV. This thesis is a step forward in the field of environmental impact assessment by the further development and application of a carrying capacity based environmental impact approach for BIPV rooftop configurations in the Netherlands covering the impact categories energy and materials. This thesis demonstrates the effect of a joint assessment of materials and energy in the building envelope to indicate the overall environmental impact in the single non-weighted indicator EL, related to the carrying capacity. To minimize environmental impact, environmental impact models and LCA application should be based on non-weighted indicators, and the carrying capacity based environmental impact LCI and equations presented and applied on a number of materials and PV technologies in this thesis is an example of a single non-weighted indicator.

The combination of results presented in this thesis provide valuable insights for the scientific community, the construction industry and policy makers. Firstly, this thesis shows that current policy focusing on energy efficiency improvement does not result in lowest building related impact. Secondly, this thesis shows that with current materials and technologies, the Netherlands will exceed its carrying capacity transforming the building stock towards ZEB levels. Thirdly, this thesis shows that although high efficiency PV placed in on top of rooftops generate more electricity, less efficient PV products such as Amorf-Si in a non-ventilated configuration has overall lowest carrying capacity based environment impact.

This thesis provides guidelines to LCA practitioners and developers to apply carrying capacity based environmental impact in assessment tools. After further development of underlying databases and material cycles, the developed LCI and equations can be embedded in mainstream environmental assessment tools or can be applied independently.

Reflections

Environmental assessment in the built environment is a broad field, in which different competences and databases converge in different models that are applied in the construction industry worldwide, in local, regional and national circumstances and traditions. Within this vast amount of influential characteristics this thesis presents a framework to assess the level of sustainability related to the carrying capacity and its application is demonstrated on different BIPV configurations. Given this context, a number of reflections are applicable.

The first reflection regards the ongoing debate on 'sustainable'. As outlined in chapter 2, 'truly sustainable' should not merely be based on 'needs', because it is difficult to quantify and can be infinite (from a metabolic and theoretical point of view we do not 'need' as much goods as we consume currently). Sustainable should therefore be more related to the limited carrying capacity of our environment, closing the relation between actual possibilities and consumption on a relatable timescale (e.g. the lifespan of a building or PV system).

The second reflection is derived from the first one. Coping with environmental issues is an ongoing societal debate. Consequently, environmental assessment models need to be (further) developed to provide insight in the environmental impact. In this development transparency is essential in data collection, weighting between data and the limitations of the model. The first – data collection – is difficult due to the limited access of actual data by producers and rapidly changing data. We argue in this thesis that primary data should be made available so that research can be done independently and objectively. We argue in this thesis, that the second – weighting of data - should be prevented.

The third reflection, regarding carrying capacity based environmental impact assessment, is that the concept of relating environmental impact to physical boundaries and physical flows is not new (e.g. the ecological footprint concept and the emergy concept). The further development and application of the MAXergy approach as a tool for carrying capacity approach in this thesis should be seen as one of the building blocks to come to a complete assessment related to carrying capacity.

The fourth reflection is that the availability and uncertainty of data influence the outcomes. Considering the methodology, data from different databases are used and translated into land-time for both the carrying capacity and the claim on carrying capacity. This translation depends on numerous factors, such as solar radiation (inclination, orientation, and geographic location), soil type, lifespan of the building and installation, phases included in the data, etc. Considering the data used, these are often from other geographic locations, depending on innovations (such as in the solar industry) and shows a large bandwidth (for instance in the field of embodied energy of solar modules). As this thesis presents the applied tools and datasets show significant differences in outcome. To decrease the bandwidth of results and to establish the carrying capacity, location specific data should be developed and validated.

The fifth reflection is on the discrepancy between the BIPV supply side and the construction industry demand side. BIPV is seen as one of the key development tracks of PV towards mass application to fulfil our energy demand. One of the main challenges for the BIPV community is bridging the gap between the highly innovative and fast changing PV supply side and the solid construction industry demand side to exploit the potential of BIPV. Better understanding of the building industry by the BIPV supply side and vice versa should be stimulated.

The sixth reflection is that the development of LCA's is complex and abstract due to the vast amount of data and changing of data to come to a full inventory, including future scenarios, forecasts and economic developments on a global scale. Due to these circumstances, validation methodologies of the environmental impact assessment are still to be developed and applied.

Contribution to the research field

Building environmental impact assessment is mainly based on multi aspect analysis with a weighting to generate single indicators. These indicators are not related to carrying capacity expressed in EL. A standard methodology in the field of carrying capacity based environmental impact has to be fully developed, to accurately and completely determine the EL of a building. MAXergy, developed by researchers at the Wageningen University and the Zuyd University of Applied Sciences, offers this possibility, but the approach is still under development in the research field. In this study

the carrying capacity based environmental impact framework is developed for BIPV, consisting of the LCI and environmental assessment equations of EL. This framework can be implemented in MAXergy, other assessment tools or used stand-alone.

Within this thesis, different building environmental assessment tools have been compared covering different insulation and BIPV strategies, emphasizing the need for non-weighted carrying capacity based environment impact assessment to cope with the development towards ZEB. This thesis has resulted in the improvement of the carrying capacity based environmental impact approach MAXergy that allows a better understanding of the environmental impact of different insulation strategies and BIPV strategies in the built environment. The developed framework is useful to assess the environmental impact of BIPV application in new buildings and BIPV retrofitting of existing buildings.

Future work

Firstly, future studies have to be conducted to be able to assess other environmental impact aspects such as water, and air consumption, besides materials and energy addressed in this thesis. Correlated with this recommendation, it has to be investigated if one single indicator is able to provide insight in the complexity and interrelations of all these impact aspects.

Secondly, the accuracy of available data should be improved and differences between datasets should be resolved. Both for embodied energy and embodied land, transparent and coherent locally applicable databases have to be developed to be able to fully assess different buildings and building components. These databases should not only cover the primary phases of material extraction, production and application, but as well the End-Of-Life (EOL) scenarios re-use, recycle and circulation, cover background process impacts, and the system's boundary conditions. Moreover, methodologies applied to develop these databases should be corresponding, so that with a combination of datasets double counting or missing impact is prevented. In these databases, holistic environmental product declaration (EPD) of all materials applied in the built environment should be embedded. For the EPD, establishment of the environmental impact category 'EL' could be based on the equations described in this thesis and its references. To develop relevant EPD's, strong collaboration between building component producers, (BI) PV producers and the scientific community is necessary.

Thirdly, besides the route for circulation by means of material extraction from sea water applied in this thesis, other circulation routes have to be further investigated, e.g. recovering materials in earlier phases. Moreover, the energy system for the different EOL routes has to be further developed in relation to the local conditions of

the actual activity. E.g. sea water filtering might take place in locations with higher solar irradiation, resulting in less energy related EL.

Fourthly, to increase the applicability of the LCI and equations in relation to BIPV, actual performance of BIPV should be further studied, taking into account latest technologies and should cope with the challenge of relevance of long-term monitoring data due to technological improvements. Moreover, different PV technologies, different integration configurations, different climatic zones, and different materials in BIPV application will have to be analysed to fully map the field of BIPV related environmental impact and to contribute to the acceleration of BIPV deployment.

Fifthly, building designs and building components should be further based on EOL scenarios with low environmental impact, resulting in designs and components that are easy to separate, increasing the possibilities for re-use and recycling.

Sixthly, to increase the market penetration of BIPV not only environmental aspects have to be further investigated, but other influences as well, such as design and social-economic aspects.

Practical recommendations

Firstly, as the first *nZEB*'s and *ZEBs* are fully developed and realized, an approach has to be developed on how to handle the yearly decrease of energy generation of the PV devices applied. The decrease over time will result in changing demands to the electricity grid network and/or storage systems.

Secondly, a roadmap should be developed how to handle the large quantities of PV systems that will have to be replaced, not only from an energy perspective, but as well from a building technological, architectural and (BI) PV component perspective.

Thirdly, while the energy transition towards a low carbon energy system is taking place, policy should be developed for the built environment that is focusses on all resource consumption - energy and material related impact combined - as the main environmental impact category to prevent environmental impact suboptimisation. The policy could well be based on Life-Cycle Zero Energy Buildings (*LC-ZEB*).

Fourthly, the framework, as presented in this thesis, provides a basis for further development of (widely) used environmental impact assessment models, such as BREEAM, LEED, Greencalc, and MAXergy, increasing environmental impact awareness and providing clear guidance in BIPV design and development.

Nomenclature

AC	Alternate Current	kWp	kiloWatt peak, nominal power at STC of PV installations
A_{dc}	Alternating current	LC	Land Claim
Amorf-Si	Amorphous Silicon	LCA	Life Cycle Assessment
ASHRAE	American Society of Heating, Refrigerating and Air Conditioning Engineers	LCI	Life Cycle Inventory
BAPV	Building Added PhotoVoltaics	LC-ZEB	Life cycle Zero Energy Building
BAU	Business As Usual scenario	Mtoe	Million tonnes of oil equivalent
BIPV	Building Integrated PhotoVoltaics	Multi-Si	Multicrystalline Silicon
BSC	BackSide Contact	MV	Mechanical Ventilation
CESBA	Common European Sustainable Built Environment Assessment	MWT	Metal Wrap Through
CIGS	Copper Indium Gallium Selenide	NEN	Nederlands Normalisatie Instituut
CO ₂	Carbon Dioxide	η_G	Grid efficiency, the average primary energy to electricity conversion efficiency at the demand side
COP	Coefficient Of Performance	NIMBY	Not In My BackYard - characterization of opposition, based on the believe that wind turbines are necessary but should be realized further away
DHT	Damp Heat Test	NL	the Netherlands
E_{agen}	Annual electricity generation of the PV installation	NoMyR	Not on My Roof - characterization of opposition, based on the believe that PV is necessary but should be realized further away.
E_{aoper}	Annual energy demand for operation and maintenance of the PV installation	NREL	National Renewable Energy Laboratory
EC	European Commission	NWO	Netherlands Organisation for Scientific Research
EC-JRC	European Commission Joint Research Centre	nZEB	nearly Zero Energy Building
EE	Embodied Energy	OE	Operational Energy

E_{emb}	Primary energy demand necessary for the realization of the PV installation	OPT	Optimistic scenario
E_{EOL}	Primary energy demand for end-of-life management of the PV installation	PEC	Primary Energy Consumption
E_{gen}	Energy generated over lifespan of the installation	PF	Phenol-Formaldehyde
E_{inst}	Primary energy demand to install the PV installation	PV	PhotoVoltaics
EL_u	Electric Luminescence	PVGIS	Photovoltaic Geographical Information System
EL	Embodied Land	PVPS	Photo Voltaic Power Systems Technological Collaboration Program of the IEA
EL_{EE}	Embodied Land necessary for embodied energy generation	RE	Renewable Energy
EL_{fact}	Embodied Land factory	REAL	Realistic scenario
EL_{mat}	Embodied Land materials	RH	Relative Humidity
EL_{pv}	Embodied Land photovoltaic device	RVO	Rijksdienst Voor Ondernemend Nederland (agentschapNL)
E_{manuf}	Primary energy demand to manufacture the PV installation	SAM	System Advisory Model
E_{mat}	Primary energy demand to produce materials for the PV installation	SEAC	Solar Energy Application Centre
$E_{non-vent}$	energy output of non-ventilated BIPV	SER	Sociaal Economische Raad
EPBD	Energy Performance Building Directive	SHC	Solar Heating and Cooling
EPBT	Energy PayBack Time	SIA	Nationaal Regieorgaan Praktijkgericht Onderzoek
EPDM	Ethylene Propylene Diene Methylene	STC	Standard Test Conditions
E_{raw}	Primary energy demand to extract raw materials for the PV installation	SUPSI	Scuola universitaria professionale della Svizzera italiana
E_{irans}	Primary energy demand for transportation during and in between the different process steps	SWB5G	Strand Woven Bamboo 5 th Generation
EU	European Union	TCT200	Temperature Cycling Test 200
EVA	Ethylene Vinyl Acetate	TDoT	The District of Tomorrow, field test location in the Netherlands
E_{vent}	Energy output of ventilated BIPV	UK	United Kingdom
FEC	Final Energy Consumption	USEIA	United States Energy Information Agency

ICE	Inventory of Carbon and Energy	V_{ac}	Alternating current voltage
IEA	International Energy Agency	V_{dc}	Direct current voltage
IEC	International Electrotechnical Commission	V_{mp}	Power point voltage
IMDEP	Innovative Material and Energy Development for the Future Building Envelop	V_{oc}	Open circuit voltage
I_{mp}	Power point current	VROM	Ministry of transportation, public space and environment
IR	Infrared	W_{ac}	Alternating current power
I_{sc}	Short circuit current	W_{dc}	Direct current power
ISO	International Organisation for Standardisation	Wp	Watt peak, nominal power at STC of PV modules
IV	Current voltage	ZEB	Zero Energy Building
KNMI	Royal Dutch Meteorological Institute	Δ_{perf}	Difference in performance
kWh	kiloWatt-hour		

List of publications

- Ritzen, M.J.: Transforming a low value coastal area into a high value natural and recreational area. In: Proceedings 21st PLEA conference, M. H. De Wit (Ed.), Eindhoven, The Netherlands, 2004.
- Ritzen, M.J., Geurts, C.P.W., Vroon, Z.A.E.P., Rovers, R. & Vervuurt, G.: Effective BIPV. In: Proceedings 7th Energy Forum on Solar Building Skins, Munich, Germany, 2012.
- Ritzen, M.J., van den Meijden, B., Rovers, R., Vroon, Z.A.E.P. & Geurts, C.P.W.: Comparison and development of sustainable office façade renovation solutions in the Netherlands. In: Journal of Facade Design and Engineering, vol. 1, no. 1-2, pp. 53-71, 2013
- Ritzen, M.J., Rovers, R., Gommans, L., Geurts, C.P.W., Vroon, Z.A.E.P. & Sigwarth, S.: Insulation versus installation - an exploration towards maximization. In Proceedings SB13, G. Hauser, T. Lutzenkorf & N. Essig (Eds.), Munich, Germany, 2013.
- Arkenbosch, R., Nieuwkamer, L. & Ritzen, M.J.: Strategy development of adaptive reuse of churches in the Netherlands. In: Proceedings ICBEST, R.D. Lieb (Ed.), Aachen, Germany, 2014.
- Ritzen, M.J., Vroon, Z.A.E.P., Rovers, R. & Geurts, C.P.W.: Comparative performance assessment of four BIPV roof solutions in the Netherlands. In: Proceedings ICBEST, R.D. Lieb (Ed.), Aachen, Germany, 2014.
- Beek, M.R., Dijk, R.M., Ritzen, M.J., Kursten, M.P., Noort, E & Geurts, C.P.W.: Ranking Responsible Source assessments for building materials. In: proceedings WSB14, Barcelona, Spain, 2014.
- Ritzen, M.J., Heumen, S., Vroon, Z.A.E.P., Rovers, R. & Geurts, C.P.W.: Innovative BIPV rooftops: development, realization, and monitoring of 2 BIPV field tests in the Netherlands. In: Proceedings 29th EU PVSEC, Amsterdam, the Netherlands, 2014.
- Ritzen, M.J., Rovers, R., Vroon, Z.A.E.P. & Geurts, C.P.W.: Making the assessment right, or making the right assessment? In: Architecture and Sustainability: Critical Perspectives for Integrated Design, K. Allacker & A. Khan (Eds.), pp. 199-214, Sint-Lucas Architecture Press, Leuven, 2015.

- Ritzen, M.J., Haagen, T.H.J., Rovers, R., Vroon, Z.A.E.P. & Geurts, C.P.W.: Environmental impact evaluation of energy saving and energy generation: case study for two Dutch dwelling types. In: *Building and Environment*, vol. 108, pp. 73-84, 2016
- Ritzen, M.J., Vroon, Z.A.E.P. & Geurts, C.P.W.: Building Integrated Photovoltaics. In: *Photovoltaic Solar Energy: From Fundamentals to Applications*, A. Reinders, P. Verlinden, W. van Sark & A. Freundlich (Eds.), pp. 579-590, Wiley, London, 2017
- Ritzen, M.J., Vroon, Z.A.E.P., Rovers, R. & Geurts, C.P.W.: Comparative performance assessment of a non-ventilated and ventilated BIPV rooftop configurations in the Netherlands. In: *Solar Energy*, vol. 146, pp. 389-400, 2017
- Ritzen, M.J., Vroon, Z.A.E.P., Rovers, R., Lupíšek, A. & Geurts, C.P.W.: Environmental impact comparison of a ventilated and a non-ventilated building integrated photovoltaic rooftop design in the Netherlands: Electricity output, energy pay-back time, and land claim. In: *Solar Energy*, vol. 155, pp. 304-313, 2017

Curriculum Vitae

Michiel Ritzen was born on the 7th of October 1976 in Delft, the Netherlands. After finishing his pre-university education in 1995 at the Sint-Stanislascollege in Delft, he studied Architecture at Delft University of Technology in the Netherlands. He received his Master degree in Architecture, specialization Technology in Sustainable Design, from this university in 2004 on a thesis on zero energy transformation of a jack-up drilling platform into a hotel. In 2003, he received the second prize in the design competition 'North Sea delta, future in abundance', with his graduation project. In 2004, he received the first poster prize at the PLEA conference with his graduation project. Until 2010, Michiel Ritzen worked for several architectural firms as an architect, sustainable energy expert and environmental impact assessor. In 2006, he won the first prize in the Mosae Ponte design competition with the sustainable design of a park and buildings on the banks of the Maas in Maastricht, the Netherlands. In 2012 he started a PhD project at the Eindhoven University of Technology, the Netherlands, the results of which are presented in this dissertation. Currently he is a senior researcher at Zuyd University of Applied Sciences in Heerlen, the Netherlands. His current research covers the design, realization and testing of BIPV solutions, BIPV related environmental impact assessment, (inter)national BIPV project management, and circular building technology. Michiel Ritzen is board member of the international initiative for a Sustainable Built Environment (iiSBE), board member of Environmental Advisors and Architects (EnviAA), member of the Green Office Maastricht University Supervisory Board and member of the advisory board of the European H2020 research project PVSITES.

Acknowledgements

I would like to thank the following persons who guided me along the track I have followed towards this milestone.

Firstly, I would like to thank the people who inspired me to become a sustainable architect; Cees, Diederik, Klaas and all the others at Cees Dam and Partners who lighted my fire for architecture; Bart van der Pot and his colleagues of Homeplan in the Netherlands and in Mexico City, where it became evident to me that we should alter our course in the construction industry towards a more sustainable one; Kees Duyvesteijn, my attic roommates Anne and Michiel 'der Alte', and the whole team of BOOM, who showed me that good architecture can merely be realized if it is sustainable; And after my study, Stefan Ritzen and his team at Bureau Ritzen who provided me with an excellent learning environment of the whole design and construction process; Joop Petit, Robert Savelkoul, and all the others at SATIJNplus Architects, where I had the opportunity to bring sustainability towards the construction industry; and my colleague board members of EnviAA, Erol Oztan and later on Jack Vroomen, for bringing sustainability into the community of South Limburg .

In the past years, I have enjoyed the good and critical company of all my colleagues at Zuyd University, where Leo Gommans opened the door for me and Bert Schroën and Ronald Rovers got me on board. Without them I would not be where I stand today. Thank you for your trust in me. At this place, I like to specially thank my colleague George Vervuurt, who was my great support and roommate in the first years of my PhD but passed away much too early. Moreover, I would like to thank my colleagues and friends of iiSBE and IEA PVPS, especially of Task 15, all the partners (professionals and students!) in our research projects, and our partners in The District of Tomorrow.

I am most grateful to my PhD supervisors Chris Geurts, Ronald Rovers, Zeger Vroon and Bert Blocken for their inspiration, reflection, critics, and support. Chris, you motivated me to use a sharp pencil and not a paint-brush, and motivated me deep down in a single topic; Ronald, you inspired me with your puzzling calculations and enthusiasm for sustainable building; Zeger, you have been a great daily supervisor, with clear targets and down to earth, but as well sharp on the goals. If I have the car you

can always hitch a ride in case you are too late, lost your keys, broke your bike or... And last but not least Bert, you joined our team at a late stage, but have been a great support especially in the final stages of writing papers and this dissertation. Together you have been excellent coaches for me.

I would also like to thank prof.dr.ir. Jan Hensen, prof.dr.ir. Andy van den Dobbelen and prof.dr.ir. Geert Verbong for being part of my doctoral committee, reviewing my thesis and giving valuable feedback.

My two paranymphs, Carlijn and Wendy, thank you for standing next to me and helping me with the organization of my defense.

My lifetime friends of The Clan. Thanks for all the discussions– of which some you did not like nor intended to have with me – and all the other memorable events we enjoyed together.

Many thanks are for my parents, Jo and Hanneke, for supporting me in all the choices I have made and trusting me to redesign your home in Bunde, giving me the first opportunity to bring into practice what I had learned. Thank you for not only being there for me, but also for taking care of Jara, Torben and Meri!

And last but not least... Tanja, thank you for paving the way for me with your own PhD. Doing two PhDs under one roof certainly has some advantages. Thank you for all your support, flexibility and help on the crucial moments. It is great to be a team with you!

For me this journey was as a sailing journey which I have enjoyed greatly. Adjusting to the currents, winds, and rounding buoys, with a clear finish line in sight and a safe harbor to retreat to. Now it is time to rig the ship for the next journey...



Bouwstenen

Bouwstenen is een publikatiereeks van de Faculteit Bouwkunde, Technische Universiteit Eindhoven.

Zij presenteert resultaten van onderzoek en andere activiteiten op het vakgebied der Bouwkunde, uitgevoerd in het kader van deze Faculteit.

Bouwstenen zijn telefonisch te bestellen op nummer

040 - 2472383

Kernredactie

MTOZ

Reeds verschenen in de serie Bouwstenen

nr 1

Elan: A Computer Model for Building Energy Design: Theory and Validation

Martin H. de Wit

H.H. Driessen

R.M.M. van der Velden

nr 2

Kwaliteit, Keuzevrijheid en Kosten:
Evaluatie van Experiment Klarendal,
Arnhem

J. Smeets

C. le Nobel

M. Broos

J. Frenken

A. v.d. Sanden

nr 3

Crooswijk:
Van 'Bijzonder' naar 'Gewoon'

Vincent Smit

Kees Noort

nr 4

Staal in de Woningbouw

Edwin J.F. Delsing

nr 5

Mathematical Theory of Stressed
Skin Action in Profiled Sheeting with
Various Edge Conditions

Andre W.A.M.J. van den Bogaard

nr 6

Hoe Berekenbaar en Betrouwbaar is
de Coëfficiënt k in x -sigma en x -ks?

K.B. Lub

A.J. Bosch

nr 7

Het Typologisch Gereedschap:
Een Verkennende Studie Omtrent
Typologie en Omtrent de Aanpak
van Typologisch Onderzoek

J.H. Luiten

nr 8

Informatievoorziening en
Beheerprocessen

A. Nauta

Jos Smeets (red.)

Helga Fassbinder (projectleider)

Adrie Proveniers

J. v.d. Moosdijk

nr 9

Strukturering en Verwerking van
Tijdgegevens voor de Uitvoering
van Bouwwerken

ir. W.F. Schaefer

P.A. Erkelens

nr 10

Stedebouw en de Vorming van
een Speciale Wetenschap

K. Doevendans

nr 11

Informatica en Ondersteuning
van Ruimtelijke Besluitvorming

G.G. van der Meulen

nr 12

Staal in de Woningbouw,
Korrosie-Bescherming van
de Begane Grondvloer

Edwin J.F. Delsing

nr 13

Een Thermisch Model voor de
Berekening van
Staalplaatbetonvloeren onder
Brandomstandigheden
A.F. Hamerlinck

nr 14

De Wijkgedachte in Nederland:
Gemeenschapsstreven in een
Stedebouwkundige Context
K. Doevendans
R. Stolzenburg

nr 15

Diaphragm Effect of Trapezoidally
Profiled Steel Sheets:
Experimental Research into the
Influence of Force Application
Andre W.A.M.J. van den Bogaard

nr 16

Versterken met Spuit-Ferrocement:
Het Mechanische Gedrag van met
Spuit-Ferrocement Versterkte
Gewapend Betonbalken
K.B. Lubir
M.C.G. van Wanroy

nr 17

De Tractaten van
Jean Nicolas Louis Durand
G. van Zeyl

nr 18

Wonen onder een Plat Dak:
Drie Opstellen over Enkele
Vooronderstellingen van de
Stedebouw
K. Doevendans

nr 19

Supporting Decision Making
Processes: A Graphical and
Interactive Analysis of Multivariate
Data
W. Adams

nr 20

Self-Help Building Productivity:
A Method for Improving House
Building by Low-Income Groups
Applied to Kenya 1990-2000
P. A. Erkelens

nr 21

De Verdeling van Woningen:
Een Kwestie van Onderhandelen
Vincent Smit

nr 22

Flexibiliteit en Kosten in het
Ontwerpproces:
Een Besluitvormingondersteunend
Model
M. Prins

nr 23

Spontane Nederzettingen Begeleid:
Voorwaarden en Criteria in Sri Lanka
Po Hin Thung

nr 24

Fundamentals of the Design of
Bamboo Structures
Oscar Arce-Villalobos

nr 25

Concepten van de Bouwkunde
M.F.Th. Bax (red.)
H.M.G.J. Trum (red.)

nr 26

Meaning of the Site
Xiaodong Li

nr 27

Het Woonmilieu op Begrip Gebracht:
Een Speurtocht naar de Betekenis van
het Begrip 'Woonmilieu'
Jaap Ketelaar

nr 28

Urban Environment in Developing
Countries
editors: Peter A. Erkelens
George G. van der Meulen (red.)

nr 29

Strategische Plannen voor de Stad:
Onderzoek en Planning in Drie
Steden
prof.dr. H. Fassbinder (red.)
H. Rikhof (red.)

nr 30

Stedebouwkunde en Stadsbestuur
Piet Beekman

nr 31

De Architectuur van Djenné:
Een Onderzoek naar de Historische
Stad
P.C.M. Maas

nr 32

Conjoint Experiments and Retail
Planning
Harmen Oppewal

nr 33

Strukturformen Indonesischer
Bautechnik: Entwicklung
Methodischer Grundlagen
für eine 'Konstruktive Pattern
Language' in Indonesien
Heinz Frick arch. SIA

nr 34

Styles of Architectural Designing:
Empirical Research on Working Styles
and Personality Dispositions
Anton P.M. van Bakel

nr 35

Conjoint Choice Models for Urban
Tourism Planning and Marketing
Benedict Dellaert

nr 36

Stedelijke Planvorming als Co-
Productie
Helga Fassbinder (red.)

nr 37

Design Research in the Netherlands
editors: R.M. Oxman
M.F.Th. Bax
H.H. Achten

nr 38

Communication in the Building
Industry
Bauke de Vries

nr 39

Optimaal Dimensioneren van
Gelaste Plaatliggers
J.B.W. Stark
F. van Pelt
L.F.M. van Gorp
B.W.E.M. van Hove

nr 40

Huisvesting en Overwinning van
Armoede
P.H. Thung
P. Beekman (red.)

nr 41

Urban Habitat:
The Environment of Tomorrow
George G. van der Meulen
Peter A. Erkelens

nr 42

A Typology of Joints
John C.M. Olie

nr 43

Modeling Constraints-Based Choices
for Leisure Mobility Planning
Marcus P. Stemerding

nr 44

Activity-Based Travel Demand
Modeling
Dick Ettema

nr 45

Wind-Induced Pressure Fluctuations
on Building Facades
Chris Geurts

nr 46

Generic Representations

Henri Achten

nr 47

Johann Santini Aichel:

Architectuur en Ambiguiteit

Dirk De Meyer

nr 48

Concrete Behaviour in Multiaxial

Compression

Erik van Geel

nr 49

Modelling Site Selection

Frank Witlox

nr 50

Ecolemma Model

Ferdinand Beetstra

nr 51

Conjoint Approaches to Developing

Activity-Based Models

Donggen Wang

nr 52

On the Effectiveness of Ventilation

Ad Roos

nr 53

Conjoint Modeling Approaches for

Residential Group preferences

Eric Molin

nr 54

Modelling Architectural Design

Information by Features

Jos van Leeuwen

nr 55

A Spatial Decision Support System for

the Planning of Retail and Service

Facilities

Theo Arentze

nr 56

Integrated Lighting System Assistant

Ellie de Groot

nr 57

Ontwepend Leren, Leren Ontwerpen

J.T. Boekholt

nr 58

Temporal Aspects of Theme Park

Choice Behavior

Astrid Kemperman

nr 59

Ontwerp van een Geïndustrialiseerde

Funderingswijze

Faas Moonen

nr 60

Merlin: A Decision Support System

for Outdoor Leisure Planning

Manon van Middelkoop

nr 61

The Aura of Modernity

Jos Bosman

nr 62

Urban Form and Activity-Travel

Patterns

Daniëlle Snellen

nr 63

Design Research in the Netherlands

2000

Henri Achten

nr 64

Computer Aided Dimensional Control

in Building Construction

Rui Wu

nr 65

Beyond Sustainable Building

editors: Peter A. Erkelens

Sander de Jonge

August A.M. van Vliet

co-editor: Ruth J.G. Verhagen

nr 66

Das Globalrecyclingfähige Haus

Hans Löfflad

nr 67

Cool Schools for Hot Suburbs

René J. Dierkx

nr 68

A Bamboo Building Design Decision Support Tool

Fitri Mardjono

nr 69

Driving Rain on Building Envelopes

Fabien van Mook

nr 70

Heating Monumental Churches

Henk Schellen

nr 71

Van Woningverhuurder naar

Aanbieder van Woongenot

Patrick Dogge

nr 72

Moisture Transfer Properties of

Coated Gypsum

Emile Goossens

nr 73

Plybamboo Wall-Panels for Housing

Guillermo E. González-Beltrán

nr 74

The Future Site-Proceedings

Ger Maas

Frans van Gassel

nr 75

Radon transport in

Autoclaved Aerated Concrete

Michel van der Pal

nr 76

The Reliability and Validity of

Interactive Virtual Reality Computer

Experiments

Amy Tan

nr 77

Measuring Housing Preferences Using

Virtual Reality and Belief Networks

Maciej A. Orzechowski

nr 78

Computational Representations of Words and Associations in

Architectural Design

Nicole Segers

nr 79

Measuring and Predicting Adaptation

in Multidimensional Activity-Travel

Patterns

Chang-Hyeon Joh

nr 80

Strategic Briefing

Fayez Al Hassan

nr 81

Well Being in Hospitals

Simona Di Cicco

nr 82

Solares Bauen:

Implementierungs- und Umsetzungs-

Aspekte in der Hochschulausbildung

in Österreich

Gerhard Schuster

nr 83

Supporting Strategic Design of

Workplace Environments with

Case-Based Reasoning

Shauna Mallory-Hill

nr 84

ACCEL: A Tool for Supporting

Concept Generation in the Early

Design Phase

Maxim Ivashkov

nr 85

Brick-Mortar Interaction in Masonry

under Compression

Ad Vermeltfoort

nr 86

Zelfredzaam Wonen

Guus van Vliet

nr 87

Een Ensemble met Grootstedelijke
Allure
Jos Bosman
Hans Schippers

nr 88

On the Computation of Well-
Structured Graphic Representations in
Architectural Design
Henri Achten

nr 89

De Evolutie van een West-Afrikaanse
Vernaculaire Architectuur
Wolf Schijns

nr 90

ROMBO Tactiek
Christoph Maria Ravesloot

nr 91

External Coupling between Building
Energy Simulation and Computational
Fluid Dynamics
Ery Djunaedy

nr 92

Design Research in the Netherlands
2005
editors: Henri Achten
Kees Dorst
Pieter Jan Stappers
Bauke de Vries

nr 93

Ein Modell zur Baulichen
Transformation
Jalil H. Saber Zaimian

nr 94

Human Lighting Demands:
Healthy Lighting in an Office
Environment
Myriam Aries

nr 95

A Spatial Decision Support System for
the Provision and Monitoring of
Urban Greenspace
Claudia Pelizaro

nr 96

Leren Creëren
Adri Proveniers

nr 97

Simlandscape
Rob de Waard

nr 98

Design Team Communication
Ad den Otter

nr 99

Humaan-Ecologisch
Georiënteerde Woningbouw
Juri Czabanowski

nr 100

Hambase
Martin de Wit

nr 101

Sound Transmission through Pipe
Systems and into Building Structures
Susanne Bron-van der Jagt

nr 102

Het Bouwkundig Contrapunt
Jan Francis Boelen

nr 103

A Framework for a Multi-Agent
Planning Support System
Dick Saarloos

nr 104

Bracing Steel Frames with Calcium
Silicate Element Walls
Bright Mweene Ng'andu

nr 105

Naar een Nieuwe Houtskeletbouw
F.N.G. De Medts

nr 106 and 107

Niet gepubliceerd

nr 108

Geborgenheid
T.E.L. van Pinxteren

nr 109

Modelling Strategic Behaviour in
Anticipation of Congestion
Qi Han

nr 110

Reflecties op het Woondomein
Fred Sanders

nr 111

On Assessment of Wind Comfort
by Sand Erosion
Gábor Dezsö

nr 112

Bench Heating in Monumental
Churches Dionne Limpens-Neilen

nr 113

RE. Architecture
Ana Pereira Roders

nr 114

Toward Applicable Green
Architecture
Usama El Fiky

nr 115

Knowledge Representation under
Inherent Uncertainty in a Multi-Agent
System for Land Use Planning
Liyang Ma

nr 116

Integrated Heat Air and Moisture
Modeling and Simulation
Jos van Schijndel

nr 117

Concrete Behaviour in Multiaxial
Compression
J.P.W. Bongers

nr 118

The Image of the Urban Landscape
Ana Moya Pellitero

nr 119

The Self-Organizing City in Vietnam
Stephanie Geertman

nr 120

A Multi-Agent Planning Support
System for Assessing Externalities
of Urban Form Scenarios
Rachel Katoshevski-Cavari

nr 121

Den Schulbau Neu Denken,
Fühlen und Wollen
Urs Christian Maurer-Dietrich

nr 122

Peter Eisenman Theories and
Practices
Bernhard Kormoss

nr 123

User Simulation of Space Utilisation
Vincent Tabak

nr 125

In Search of a Complex System Model
Oswald Devisch

nr 126

Lighting at Work:
Environmental Study of Direct Effects
of Lighting Level and Spectrum on
Psycho-Physiological Variables
Grazyna Górnicka

nr 127

Flanking Sound Transmission through
Lightweight Framed Double Leaf
Walls
Stefan Schoenwald

nr 128

Bounded Rationality and Spatio-
Temporal Pedestrian Shopping
Behavior
Wei Zhu

nr 129

Travel Information:
Impact on Activity Travel Pattern
Zhongwei Sun

nr 130

Co-Simulation for Performance Prediction of Innovative Integrated Mechanical Energy Systems in Buildings

Marija Trcka

nr 131

Niet gepubliceerd

nr 132

Architectural Cue Model in Evacuation Simulation for Underground Space Design

Chengyu Sun

nr 133

Uncertainty and Sensitivity Analysis in Building Performance Simulation for Decision Support and Design Optimisation

Christina Hopfe

nr 134

Facilitating Distributed Collaboration in the AEC/FM Sector Using Semantic Web Technologies

Jacob Beetz

nr 135

Circumferentially Adhesive Bonded Glass Panes for Bracing Steel Frame in Façades

Edwin Huvener

nr 136

Influence of Temperature on Concrete Beams Strengthened in Flexure with CFRP

Ernst-Lucas Klamer

nr 137

Sturen op Klantwaarde

Jos Smeets

nr 139

Lateral Behavior of Steel Frames with Discretely Connected Precast Concrete Infill Panels

Paul Teewen

nr 140

Integral Design Method in the Context of Sustainable Building Design

Perica Savanovic

nr 141

Household Activity-Travel Behavior: Implementation of Within-Household Interactions

Renni Anggraini

nr 142

Design Research in the Netherlands 2010

Henri Achten

nr 143

Modelling Life Trajectories and Transport Mode Choice Using Bayesian Belief Networks

Marloes Verhoeven

nr 144

Assessing Construction Project Performance in Ghana

William Gyadu-Asiedu

nr 145

Empowering Seniors through Domotic Homes

Masi Mohammadi

nr 146

An Integral Design Concept for Ecological Self-Compacting Concrete

Martin Hunger

nr 147

Governing Multi-Actor Decision Processes in Dutch Industrial Area Redevelopment

Erik Blokhuis

nr 148

A Multifunctional Design Approach for Sustainable Concrete

Götz Hüsken

nr 149

Quality Monitoring in Infrastructural Design-Build Projects

Ruben Favié

nr 150

Assessment Matrix for Conservation of Valuable Timber Structures

Michael Abels

nr 151

Co-simulation of Building Energy Simulation and Computational Fluid Dynamics for Whole-Building Heat, Air and Moisture Engineering

Mohammad Mirsadeghi

nr 152

External Coupling of Building Energy Simulation and Building Element Heat, Air and Moisture Simulation

Daniel Cóstola

nr 153

Adaptive Decision Making In Multi-Stakeholder Retail Planning

Ingrid Janssen

nr 154

Landscape Generator

Kymo Slager

nr 155

Constraint Specification in Architecture

Remco Niemeijer

nr 156

A Need-Based Approach to Dynamic Activity Generation

Linda Nijland

nr 157

Modeling Office Firm Dynamics in an Agent-Based Micro Simulation Framework

Gustavo Garcia Manzato

nr 158

Lightweight Floor System for Vibration Comfort

Sander Zegers

nr 159

Aanpasbaarheid van de Draagstructuur

Roel Gijsbers

nr 160

'Village in the City' in Guangzhou, China

Yanliu Lin

nr 161

Climate Risk Assessment in Museums

Marco Martens

nr 162

Social Activity-Travel Patterns

Pauline van den Berg

nr 163

Sound Concentration Caused by Curved Surfaces

Martijn Vercammen

nr 164

Design of Environmentally Friendly Calcium Sulfate-Based Building Materials:

Towards an Improved Indoor Air Quality

Qingliang Yu

nr 165

Beyond Uniform Thermal Comfort on the Effects of Non-Uniformity and Individual Physiology

Lisje Schellen

nr 166

Sustainable Residential Districts

Gaby Abdalla

nr 167

Towards a Performance Assessment
Methodology using Computational
Simulation for Air Distribution System
Designs in Operating Rooms
Mônica do Amaral Melhado

nr 168

Strategic Decision Modeling in
Brownfield Redevelopment
Brano Glumac

nr 169

Pamela: A Parking Analysis Model
for Predicting Effects in Local Areas
Peter van der Waerden

nr 170

A Vision Driven Wayfinding
Simulation-System Based on the
Architectural Features Perceived in the
Office Environment
Qunli Chen

nr 171

Measuring Mental Representations
Underlying Activity-Travel Choices
Oliver Horeni

nr 172

Modelling the Effects of Social
Networks on Activity and Travel
Behaviour
Nicole Ronald

nr 173

Uncertainty Propagation and
Sensitivity Analysis Techniques in
Building Performance Simulation to
Support Conceptual Building and
System Design
Christian Struck

nr 174

Numerical Modeling of Micro-Scale
Wind-Induced Pollutant Dispersion
in the Built Environment
Pierre Gousseau

nr 175

Modeling Recreation Choices
over the Family Lifecycle
Anna Beatriz Grigolon

nr 176

Experimental and Numerical Analysis
of Mixing Ventilation at Laminar,
Transitional and Turbulent Slot
Reynolds Numbers
Twan van Hooff

nr 177

Collaborative Design Support:
Workshops to Stimulate Interaction
and Knowledge Exchange Between
Practitioners
Emile M.C.J. Quanjel

nr 178

Future-Proof Platforms for Aging-in-
Place
Michiel Brink

nr 179

Motivate:
A Context-Aware Mobile Application
for Physical Activity Promotion
Yuzhong Lin

nr 180

Experience the City:
Analysis of Space-Time Behaviour
and Spatial Learning
Anastasia Moiseeva

nr 181

Unbonded Post-Tensioned Shear
Walls of Calcium Silicate Element
Masonry
Lex van der Meer

nr 182

Construction and Demolition Waste
Recycling into Innovative Building
Materials for Sustainable Construction
in Tanzania
Mwita M. Sabai

nr 183

Durability of Concrete
with Emphasis on Chloride Migration
Przemysław Spiesz

nr 184

Computational Modeling of Urban
Wind Flow and Natural Ventilation
Potential of Buildings
Rubina Ramponi

nr 185

A Distributed Dynamic Simulation
Mechanism for Buildings Automation
and Control Systems
Azzedine Yahiaoui

nr 186

Modeling Cognitive Learning of
Urban Networks in Daily Activity-
Travel Behavior
Sehnaz Cenani Durmazoglu

nr 187

Functionality and Adaptability of
Design Solutions for Public Apartment
Buildings in Ghana
Stephen Agyefi-Mensah

nr 188

A Construction Waste Generation
Model for Developing Countries
Lilliana Abarca-Guerrero

nr 189

Synchronizing Networks:
The Modeling of Supernetworks for
Activity-Travel Behavior
Feixiong Liao

nr 190

Time and Money Allocation Decisions
in Out-of-Home Leisure Activity
Choices
Gamze Zeynep Dane

nr 191

How to Measure Added Value of CRE
and Building Design
Rianne Appel-Meulenbroek

nr 192

Secondary Materials in Cement-Based
Products:
Treatment, Modeling and
Environmental Interaction
Miruna Florea

nr 193

Concepts for the Robustness
Improvement of Self-Compacting
Concrete:
Effects of Admixtures and Mixture
Components on the Rheology and
Early Hydration at Varying
Temperatures
Wolfram Schmidt

nr 194

Modelling and Simulation of Virtual
Natural Lighting Solutions in Buildings
Rizki A. Mangkuto

nr 195

Nano-Silica Production at Low
Temperatures from the Dissolution of
Olivine - Synthesis, Tailoring and
Modelling
Alberto Lazaro Garcia

nr 196

Building Energy Simulation Based
Assessment of Industrial Halls for
Design Support
Bruno Lee

nr 197

Computational Performance
Prediction of the Potential of Hybrid
Adaptable Thermal Storage Concepts
for Lightweight Low-Energy Houses
Pieter-Jan Hoes

nr 198

Application of Nano-Silica in
Concrete
George Quercia Bianchi

nr 199

Dynamics of Social Networks and Activity Travel Behaviour

Fariya Sharmeen

nr 200

Building Structural Design Generation and Optimisation including Spatial Modification

Juan Manuel Davila Delgado

nr 201

Hydration and Thermal Decomposition of Cement/Calcium-Sulphate Based Materials

Ariën de Korte

nr 202

Republiek van Beelden: De Politieke Werkingen van het Ontwerp in Regionale Planvorming

Bart de Zwart

nr 203

Effects of Energy Price Increases on Individual Activity-Travel Repertoires and Energy Consumption

Dujuan Yang

nr 204

Geometry and Ventilation: Evaluation of the Leeward Sawtooth Roof Potential in the Natural Ventilation of Buildings

Jorge Isaac Perén Montero

nr 205

Computational Modelling of Evaporative Cooling as a Climate Change Adaptation Measure at the Spatial Scale of Buildings and Streets

Hamid Montazeri

nr 206

Local Buckling of Aluminium Beams in Fire Conditions

Ronald van der Meulen

nr 207

Historic Urban Landscapes: Framing the Integration of Urban and Heritage Planning in Multilevel Governance

Loes Veldpaus

nr 208

Sustainable Transformation of the Cities:

Urban Design Pragmatics to Achieve a Sustainable City

Ernesto Antonio Zumelzu Scheel

nr 209

Development of Sustainable Protective Ultra-High Performance Fibre Reinforced Concrete (UHPFRC): Design, Assessment and Modeling

Rui Yu

nr 210

Uncertainty in Modeling Activity-Travel Demand in Complex Urban Systems

Soora Rasouli

nr 211

Simulation-based Performance Assessment of Climate Adaptive Greenhouse Shells

Chul-sung Lee

nr 212

Green Cities:

Modelling the Spatial Transformation of the Urban Environment using Renewable Energy Technologies

Saleh Mohammadi

nr 213

A Bounded Rationality Model of Short and Long-Term Dynamics of Activity-Travel Behavior

Ifigeneia Psarra

nr 214

Effects of Pricing Strategies on
Dynamic Repertoires of Activity-Travel
Behaviour
Elaheh Khademi

nr 215

Handstorm Principles for Creative and
Collaborative Working
Frans van Gassel

nr 216

Light Conditions in Nursing Homes:
Visual Comfort and Visual
Functioning of Residents
Marianne M. Sinoo

nr 217

Woonsporen:
De Sociale en Ruimtelijke Biografie
van een Stedelijk Bouwblok in de
Amsterdamse Transvaalbuurt
Hüseyin Hüsnü Yegenoglu

nr 218

Studies on User Control in Ambient
Intelligent Systems
Berent Willem Meerbeek

nr 219

Daily Livings in a Smart Home:
Users' Living Preference Modeling of
Smart Homes
Erfaneh Allameh

nr 220

Smart Home Design:
Spatial Preference Modeling of Smart
Homes
Mohammadali Heidari Jozam

nr 221

Wonen:
Discoursen, Praktijken, Perspectieven
Jos Smeets

nr 222

Personal Control over Indoor Climate
in Offices:
Impact on Comfort, Health and
Productivity
Atze Christiaan Boerstra

nr 223

Personalized Route Finding in
Multimodal Transportation Networks
Jianwe Zhang

nr 224

The Design of an Adaptive Healing
Room for Stroke Patients
Elke Daemen

nr 225

Experimental and Numerical Analysis
of Climate Change Induced Risks to
Historic Buildings and Collections
Zara Huijbregts

nr 226

Wind Flow Modeling in Urban Areas
Through Experimental and Numerical
Techniques
Alessio Ricci

nr 227

Clever Climate Control for Culture:
Energy Efficient Indoor Climate
Control Strategies for Museums
Respecting Collection Preservation
and Thermal Comfort of Visitors
Rick Kramer

nr 228

nog niet bekend / gepubliceerd

nr 229

nog niet bekend / gepubliceerd

The continuous increase of natural resource consumption, amongst others related to the built environment, creates an increasing environmental impact. Within the European Union, it has been agreed that by the end of 2020 all new buildings must be nearly Zero Energy Buildings (nZEB's), and by the end of 2050 the complete building stock must be nZEB. The energy performance improvement to reach nZEB results in an increase of building material consumption, amongst others by the application of PhotoVoltaics (PV). PV applied in the built environment can either be added to the building envelope (BAPV) or integrated in the building envelope (BIPV). In BIPV the energy performance and material consumption show a strong interaction, which is not fully addressed in current environmental assessment tools. Moreover, these tools have important shortcomings, since they function through weighting of different indicators, are not related to carrying capacity, and are based on a linear process. The main objective of this research was to develop a framework for a non-weighted circular carrying capacity based environmental assessment of BIPV. The framework covers the environmental impact of energy performance and material consumption of BIPV, and expresses the environmental impact in the claim on carrying capacity. Two approaches were applied to realize this objective; a numerical approach in the field of environmental assessment model development, and an experimental approach covering BIPV performance measurements and environmental assessment model application in a field test.

F

A

C

B

W

H

E

H

U

/ Department of the Built Environment

TU/e

Technische Universiteit
Eindhoven
University of Technology

Zuyd
Research

**ZU
YD**