

## Multiphysics analysis helps preserve the past

***Citation for published version (APA):***

Dagastine, G., van Schijndel, A. W. M., Schellen, H. L., & Huijbregts, Z. (2016). Multiphysics analysis helps preserve the past. *Comsol News*, 2016(1), 35-37.

***Document status and date:***

Published: 21/04/2016

***Please check the document version of this publication:***

- A submitted manuscript is the version of the article upon submission and before peer-review. There can be important differences between the submitted version and the official published version of record. People interested in the research are advised to contact the author for the final version of the publication, or visit the DOI to the publisher's website.
- The final author version and the galley proof are versions of the publication after peer review.
- The final published version features the final layout of the paper including the volume, issue and page numbers.

[Link to publication](#)

***General rights***

Copyright and moral rights for the publications made accessible in the public portal are retained by the authors and/or other copyright owners and it is a condition of accessing publications that users recognise and abide by the legal requirements associated with these rights.

- Users may download and print one copy of any publication from the public portal for the purpose of private study or research.
- You may not further distribute the material or use it for any profit-making activity or commercial gain
- You may freely distribute the URL identifying the publication in the public portal.

If the publication is distributed under the terms of Article 25fa of the Dutch Copyright Act, indicated by the "Taverne" license above, please follow below link for the End User Agreement:

[www.tue.nl/taverne](http://www.tue.nl/taverne)

***Take down policy***

If you believe that this document breaches copyright please contact us at:

[openaccess@tue.nl](mailto:openaccess@tue.nl)

providing details and we will investigate your claim.

# Multiphysics Analysis Helps Preserve the Past

Students and consultants are collaborating to improve the built environment and to save historic structures and artifacts with the use of simulation apps.

by **GARY DAGASTINE**



**FIGURE 1.** From left to right, the images show different scales of structures of interest to the built environment, from large land areas down to the materials used in a window.

**T**here's always room for improvement in the things we humans create, and nowhere is this more true than in the so-called built environment, the term for human-made physical surroundings in which we live, work, and play.

The built environment encompasses everything from large metropolitan areas to individual buildings, parks, roadways, and the infrastructure with which we interact over the course of our lives. Although it may not always seem dynamic, it is continually impacted by a myriad of physics-based processes, such as heat transfer, air flow, and moisture transport, which take place on many different scales (see Figure 1).

The ability to model and simulate these processes accurately can lead to significant improvements in many important areas such as energy efficiency, health and safety, operating costs, durability, and notably, historic preservation.

Deeply immersed in this work is Jos van Schijndel, founder of Netherlands-based consulting firm CompuToolAble and assistant professor at Eindhoven University of Technology, Netherlands, where he specializes in the mathematical modeling of building physics.

"What gives me joy and energy is to work on projects that not only incorporate leading-edge research, but which are relevant to society and can also inspire my students," van Schijndel said. "I formed CompuToolAble to offer clients our

expertise in advanced mathematics and computational tools, and the ability to perform complex numerical experiments to create innovative designs and optimize their performance."

As a consultant and professor, van Schijndel often needs to think of ways to make complex ideas accessible to his clients who are not simulation experts or to students who are still learning about modeling and simulation work. As a COMSOL Multiphysics® software user, he takes advantage of its Application Builder, which enables him to build intuitive user interfaces powered by a COMSOL® software model. This allows him, as a simulation expert, to efficiently collaborate with clients and colleagues in other organizations and departments.

## ⇒ APPS FACILITATE THE USE OF NUMERICAL SIMULATION

To his corporate clients, van Schijndel offers numerical analysis and testing capabilities through these customized user interfaces, or applications, built from COMSOL models. These apps make it easy for an end user who has never used the simulation software before, or who doesn't have the technical background to create a model, to run virtual tests on different design changes based on their specific needs.

In the university setting, he uses the same software to introduce students to multiphysics simulation and application design. Using COMSOL apps first gives students an entry point into numerical analysis and physics systems before they continue on to building their own models from scratch. Once they are familiar enough with the concepts and the modeling techniques, they can eventually create their own apps using

*Using COMSOL apps first gives students an entry point into numerical analysis and physics systems before they continue on to building their own models from scratch.*

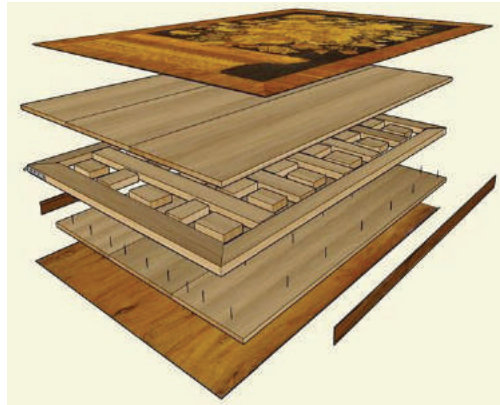

**FIGURE 2.** At left, Amerongen Castle is one example of an historic structure that is subject to the potentially damaging effects of heat- and moisture-driven stress and strain over time. This applies both to the building itself, and to the treasures the castle contains, such as the cabinet door at right (source: Rijksmuseum Amsterdam).

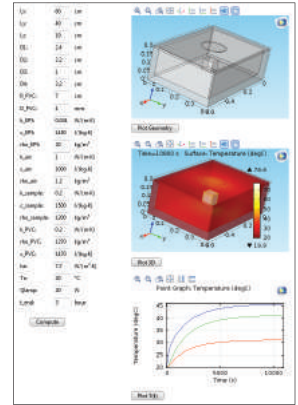

**FIGURE 3.** App users can explore a variety of designs and operating scenarios, e.g., different geometry parameters and material properties.

the Application Builder, further expanding their knowledge and the reach of their collective analysis capabilities.

“Application Builder is very important to me in two distinct ways,” van Schijndel said. “At the university, it’s an ongoing challenge to motivate students to use their creativity and ingenuity before they dive too deeply into mathematical modeling. But now, I can easily build engaging simulation apps with just the characteristics I want my students to explore. Then, only after they’ve had a chance to play with the apps to analyze the physics involved and to understand the effects when various changes are made, do we get into more detailed work.

“On the corporate side,” van Schijndel continued, “often there are people who need to use numerical simulations so that they can see and understand the impacts of physics processes on their products, but don’t have enough experience or interest in building models themselves. Using the Application Builder I am able to create a specialized user interface based on advanced numerical models and provide them with only the parameters that they are interested in. This also ensures no errors are introduced, because we are all working from the same reference point.” An app can be deployed for use by everyone who needs access to it, through either a web browser or a downloadable client and letting them connect to COMSOL Server™ product (as shown in a cropped screenshot of the app in Figure 3).

### ⇒ MULTIPHYSICS ANALYSIS AIDS HISTORIC PRESERVATION

When it comes to the preservation of historic buildings and the artifacts they contain (see Figure 2), it’s imperative to examine the combined impacts of heat transfer, air flow, and moisture transport in order to blunt their deleterious effects. Fluctuating levels of temperature and humidity can increase the stress and strain on historic structures and objects, which in turn may lead to warping, cracking, dimensional changes, and other forms of damage. Having a better understanding of the dynamics of these processes and how they occur can lead

to more effective preservation efforts.

Van Schijndel has created and overseen the creation of many COMSOL models related to the preservation of historic buildings and items in close collaboration with colleague Henk Schellen, associate professor in Physics of Monuments. For example, one of their PhD students, Zara Huijbregts, used the Heat Transfer Module, an add-on to COMSOL Multiphysics, to model how sunlight streaming through windows would heat the floor and walls of a room at different times over the course of a day (see Figure 4).

The simulation combined conductive heat transfer through the building envelope, convective heat transfer and measured indoor air, and radiant heat transfer. The model included different surfaces of

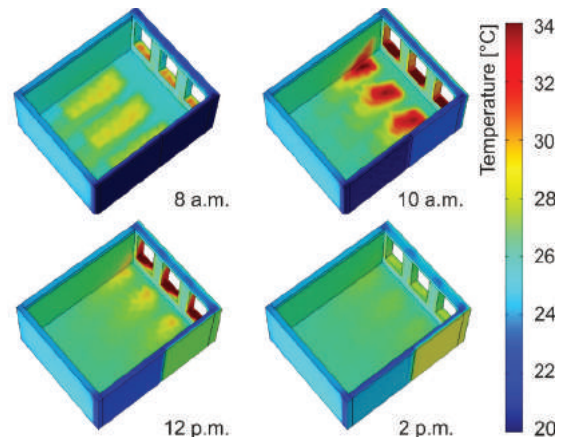
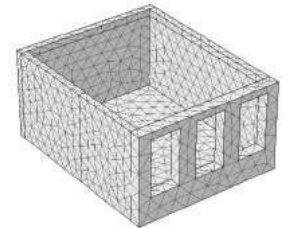

**FIGURE 4.** A numerical simulation in COMSOL® software of temperature distribution in the floor and walls of a room at different times of day. The heat comes from solar radiation streaming through the windows as the sun passes over the room.



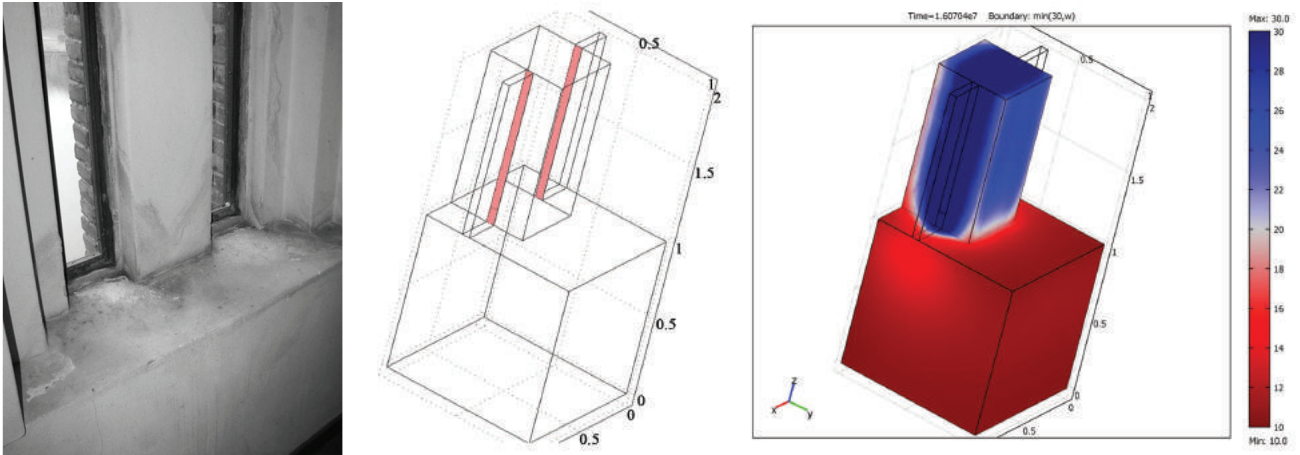

**FIGURE 5.** To understand the moisture transport, which can cause damage like that pictured above (left), van Schijndel created a COMSOL model that accurately couples heat and moisture transport through a wall (right).

the room and the building façades, and also accounted for the cooling effects of outdoor shade.

The results predicted the temperature on each wall at different times of day, indicating the best locations for protecting sensitive objects from sunlight and heat damage. “It is extremely important to know such precise temperature distributions so that, for example, paintings can be hung in locations where they will be less affected by solar heating,” van Schijndel said.

Moisture damage is another major issue that can damage walls, buildings, roofs, and the contents of a room. Because in older structures it isn’t always clear where the moisture enters a building or room, van Schijndel sometimes uses COMSOL Multiphysics as an investigative tool.

“The idea is to deduce how moisture might be entering by running multiphysics simulations that include measurements of relative humidity at many different locations. Areas of high relative humidity give clues as to how the mass transport of moisture occurs, and we couple this information with heat transfer simulations because heat drives the moisture distribution,” he said.

Van Schijndel developed a COMSOL model of moisture transport in a wall with visible leakage damages near the window. His model enabled him to deduce where the moisture was coming from (see Figure 5). He and his students used this technique to model thermal bridges using different materials, analyze how the positioning of insulation influences heat transfer from the inside to the outside of a building, and to understand how moisture travels through different building materials such as concrete, stone, and insulation (see Figure 5).

Given that temperature and humidity are major drivers of stress and strain on precious objects such as historic paintings, the ability to accurately couple these together in a model can lead to better predictions of potential damage. Van Schijndel’s model calculates the temperature distribution throughout the wall and painting, as well as the relative changes in humidity (see Figure 6).

“Historic structures are facing unprecedented threats to their integrity from climate change, increased urbanization, and other factors. At the same time, the regulations governing their preservation have never been stricter, because it is a societal benefit to preserve the legacy of the past. The ability to use sophisticated modeling and simulation tools such as COMSOL is an important part of the toolkit that helps us meet those requirements,” said van Schijndel. ❖

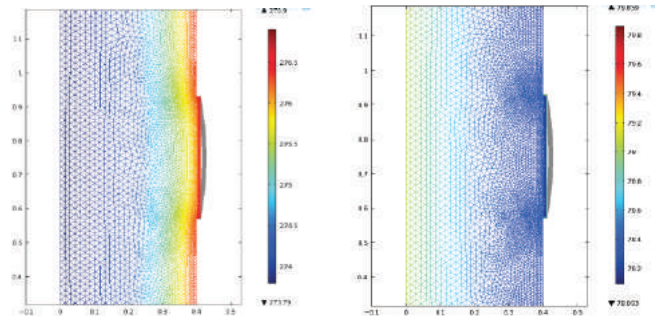

**FIGURE 6.** Both images show COMSOL simulations of a cross section of a wall on which a painting is hanging. The left image shows the temperature distribution in the wall and painting at a given point in time, while the image on the right shows the rate of change of relative humidity in the wall and the painting at that same point in time. This model can help predict stress and strain, which impacts historic buildings and artifacts, giving experts the information needed to take appropriate damage mitigation actions.

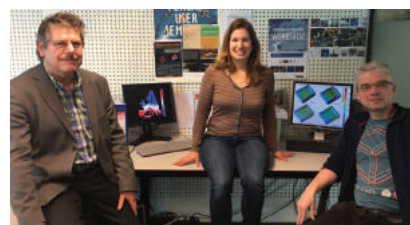

From left to right: Henk Schellen, Zara Huijbregts, and Jos van Schijndel.