

System performance of a 4-channel PHASAR WDM receiver operating at 1.2 Gbit/s

Citation for published version (APA):

Steenbergen, C. A. M., van Deventer, M. O., Vreede, de, L. C. N., Dam, van, C., Smit, M. K., & Verbeek, B. H. (1996). System performance of a 4-channel PHASAR WDM receiver operating at 1.2 Gbit/s. In *Optical Fiber Communication : OFC '96* (pp. 310-311). (OSA technical digest series; Vol. 1996,2). Optical Society of America (OSA).

Document status and date:

Published: 01/01/1996

Document Version:

Publisher's PDF, also known as Version of Record (includes final page, issue and volume numbers)

Please check the document version of this publication:

- A submitted manuscript is the version of the article upon submission and before peer-review. There can be important differences between the submitted version and the official published version of record. People interested in the research are advised to contact the author for the final version of the publication, or visit the DOI to the publisher's website.
- The final author version and the galley proof are versions of the publication after peer review.
- The final published version features the final layout of the paper including the volume, issue and page numbers.

[Link to publication](#)

General rights

Copyright and moral rights for the publications made accessible in the public portal are retained by the authors and/or other copyright owners and it is a condition of accessing publications that users recognise and abide by the legal requirements associated with these rights.

- Users may download and print one copy of any publication from the public portal for the purpose of private study or research.
- You may not further distribute the material or use it for any profit-making activity or commercial gain
- You may freely distribute the URL identifying the publication in the public portal.

If the publication is distributed under the terms of Article 25fa of the Dutch Copyright Act, indicated by the "Taverne" license above, please follow below link for the End User Agreement:

www.tue.nl/taverne

Take down policy

If you believe that this document breaches copyright please contact us at:

openaccess@tue.nl

providing details and we will investigate your claim.

3. R. L. Soderstrom *et al.*, "CD laser optical links for workstations and midrange computers," in *Proc. 43rd Electronics Components and Technology Conference*, June 1993, Orlando, Fla., pp. 505-509.
4. D. L. Rogers *et al.*, "Design, fabrication & automated testing of 32 channel integrated MSM/MESFET OEIC receiver arrays," in *Proc. on Integrated Opto-electronics*, IEEE/LEOS 1994, pp. 3-4.

FC5

9:30 am

System performance of a 4-channel PHASAR WDM receiver operating at 1.2 Gbit/s

C. A. M. Steenbergen, M. O. van Deventer,*
L. C. N. de Vreede, C. van Dam, M. K. Smit,
B. H. Verbeek,** *Department of Electrical Engineering,
Delft University of Technology, Mekelweg 4,
NL-2628 CD Delft, The Netherlands*

Phased arrays are important key components in wavelength-division multiplexing (WDM) systems.¹ We have realized a 4-channel WDM receiver combining a phased array with photodetectors on InP with a Si bipolar transimpedance amplifier.² The channels are spaced at 2.0 nm with a 1.0-nm flat passband.³ On chip loss was 6-7 dB and detector efficiency was better than 90%. The optical cross talk remains below -20 dB. The electrical bandwidth per channel was 1 GHz. The electrical cross talk at 1 GHz after detection is below -25 dB. We have tested this receiver in a full 4-channel system.

Figure 1 shows the diagram of the experimental setup. Three DFB lasers and one tunable laser were used as transmitters. The lasers were tuned to match the optical transmission windows of the WDM receiver: 1532.1, 1534.1, 1536.1, and 1538.0 nm. Two external modulators (on/off ratio 13 dB) were used, one for the signal channel, the other one for the interfering channels. A PRBS of $2^7 - 1$ was used. As our receiver was not polarization independent, polarization controllers were used to adjust the light towards TE-polarization at the input of the WDM receiver. The power levels of both were adjusted by attenuators. The combined channels were preamplified by an erbium-doped fiber amplifier (EDFA) and coupled into the re-

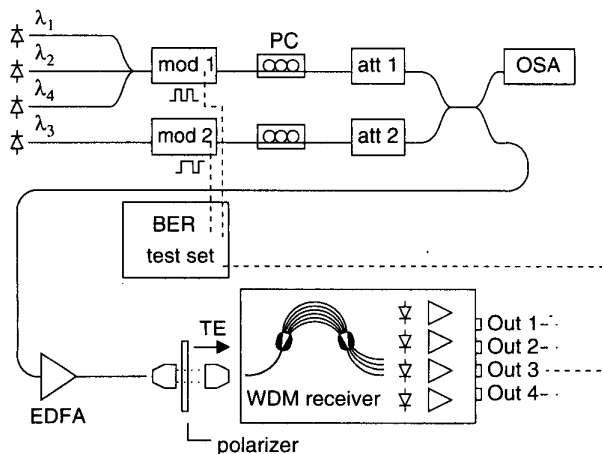

FC5 Fig. 1. Experimental setup for 4-channel WDM experiment.

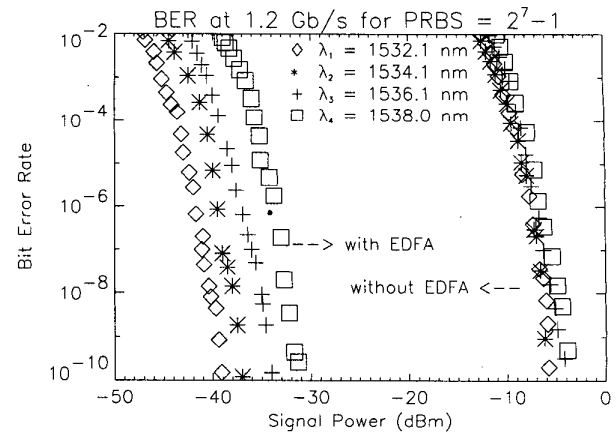

FC5 Fig. 2. Sensitivity measurements of the 4-channels with and without optical preamplification.

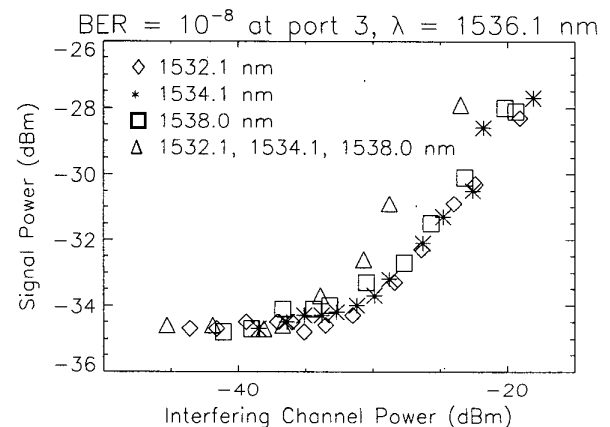

FC5 Fig. 3. Influence of interfering channels on sensitivity of channel 3. Similar figures were obtained for the other three channels.

ceiver chip by a lens system. A polarizer filtered residual TM-polarization. The electric signal was amplified, filtered by a 1-GHz low pass filter, and directed to the BER detector. No wavelength stabilization was needed, due to the flattened wavelength response (1 dB within 1.0 nm) of the demultiplexer.

Figure 2 shows the BER measurements for the four channels, without interfering channels. BER curves were measured with and without optical preamplification. The WDM receiver sensitivity, between -6 and -4 dBm, was determined by the coupling losses and the noise of the transimpedance receiver. A best preamplified receiver sensitivity of -39.5 dBm was measured. The differences in receiver sensitivity between the four channels was caused by the nonflat EDFA gain, because the EDFA gain was not sufficient to overcome the WDM receiver noise.

Figure 3 shows the influence of the interfering channels for port 3. The penalty curves were measured by adjusting both power levels of signal and interfering channels, while maintaining a BER of 10^{-8} . For a single interfering channel the penalty remains below 1 dB for operation below -30 dBm. The penalty is 2.5 dB when all three interfering channels are operating simultaneously at -30 dBm. Measurements of EDFA

gain saturation indicate that the main cause of the crosstalk penalty was homogeneous EDFA saturation.

In conclusion we have fabricated and tested a 4-channel WDM receiver, which operates at 1.2 Gb/s. Receiver sensitivity with optical preamplification is between -39.5 and -32.5 dBm. Simultaneous operation of 4 channels at a BER of 10^{-9} was demonstrated.

1. C. H. Joyner *et al.*, "An 8 channel Digitally tunable transmitter with electroabsorption modulated output by selective area epitaxy," in *IPR'95*, Vol. 7, 1995 OSA Tech. Dig. Series, paper PD2.12.
2. C. A. M. Steenbergen *et al.*, "Integrated 1 GHz 4-channel InP phasor based WDM-receiver with Si bipolar frontend array," in *Proc. ECOC'95*, Sept. 17-21, 1995, Brussels, Belgium.
3. M. R. Amersfoort, *Phased-array wavelength demultiplexers and their integration with photodetectors*, Ph.D. Thesis, Delft University of Technology, Delft, The Netherlands, 1994, ISBN 90-407-1041-4.

*KPN Research, Leidschendam, The Netherlands

**Philips Optoelectronics Centre, Eindhoven, The Netherlands

FC6

9:45 am

Characterization of a variable bit-rate receiver for applications in WDM/WDMA systems

Frank Tong, Chung-Sheng Li, Gene Berkowitz, IBM Thomas J. Watson Research Center, P.O. Box 704, Yorktown Heights, New York 10598

The protocol transparency provided by WDM and WDMA systems has the advantage of allowing network interfaces (use different protocols at different bit rates) attached to the same network. For optimized performance, the receiver has to be able to adjust to the bit rates dictated by the transmitter. A 20-channel WDM system with quasi-protocol-transparency has been commercialized recently,¹ as each line card of the system is prescribed for a specific protocol at a fixed bit rate. A receiver that is optimized for a specific bit rate can only achieve suboptimal sensitivity at lower bit rates due to excessive thermal noise allowed by the bandwidth of the receiver. Therefore, a receiver optimized for a range of bit rates is desirable for full protocol transparent operations. In order for a receiver to be optimally configured for a range of bit rates, the transimpedance of the preamplifier needs to be tunable. We propose in Ref. 2 to achieve the variable bit-rate capability by tuning the gate voltage of a microFET used as an active feedback resistor in the transimpedance amplifier. Transimpedance amplifiers using active feedback resistor have been described previously, for example, in Ref. 3. Because of their small parasitic capacitance, active feedback resistors can achieve wideband nonintegrating response and stability against ringing and oscillation. Here, we report the characteristics of a receiver whose performance can be optimized for bit rates ranging from 300 to 1,500 Mbps. The receiver is part of an eight-channel receiver array. The other seven receivers use passive feedback resistors in the transimpedance amplifiers.

Our receiver array configuration consists of an optical demultiplexer (such as that reported in Ref. 4) and a detector

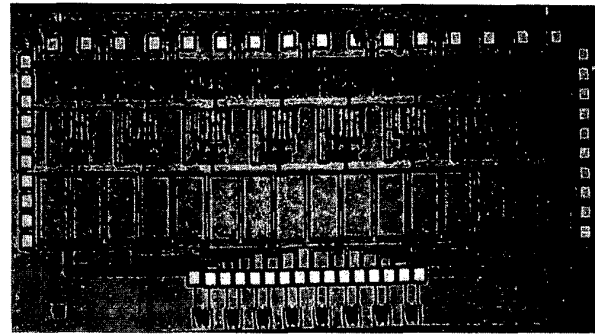

(a)

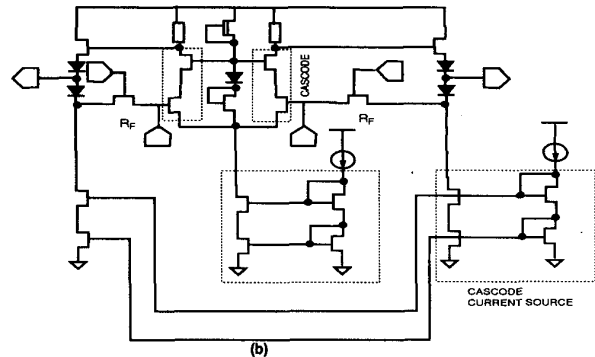

(b)

FC6 Fig. 1. (a) Chip photograph of the 8-channel receiver array. The variable bit-rate receiver is the right-most receiver in the picture (receiver 8), and the left-most receiver being receiver 1. (b) Circuit diagram of receiver 8.

array connected to the transimpedance amplifier array. The optical demultiplexer spatially resolves the input signals and each individual wavelength is then coupled to its corresponding photodetector in the array via total internal reflection at the end face of the demultiplexer. A signalling protocol is assumed to prescribe the bit-rate of each individual wavelength channel and will be discussed in Ref. 2. With the bit-rate information available, the control voltage that alters the receiver bandwidth is generated by a table lookup and a D/A operation. The data in each wavelength channel is then extracted by the timing recovery unit attached to the receiver outputs.

Figure 1 shows the photograph (a) and electronic circuitry (b) of the receiver array. As shown in the figure, each transimpedance amplifier is separated from its neighbor by $560 \mu\text{m}$. The contact pads ($250\text{-}\mu\text{m}$ pitch) were introduced for hybrid integration with detectors responsive at $1.55\text{-}\mu\text{m}$ range. The additional GaAs metal-semiconductor-metal (MSM) detectors, each separated by $250 \mu\text{m}$, were integrated with the receivers to simplify testing. The transimpedance amplifiers utilize a gate length of $1.2 \mu\text{m}$ with a transconductance g_m of 140 mS/mm , f_T of 15 GHz and combined C_{gs} (gate-source capacitance) and C_{gd} (gate-drain capacitance) of 500 fF . A microFET with identical channel width and channel length of $1.2 \mu\text{m}$ is used as an active feedback resistor whose gate bias can be set externally [receiver 8 in Fig. 1(a)]. Note that because of the differential front-end design, there are AC coupling capacitors of 14.3 pF located at the inputs of the amplifiers. Due to these capacitors, the receiver requires the input data to be line coded by, for example, 8/10 code to eliminate frequency components