

First CAD-tool for simulating complex photonic integrated circuits

Citation for published version (APA):

Leijtens, X. J. M., Lourec, Le, P., Vreeburg, C. G. M., Uitterdijk, T., & Smit, M. K. (1996). First CAD-tool for simulating complex photonic integrated circuits. In A. Driessen, & R. M. de Ridder (Eds.), *Proceedings 1996 IEEE/LEOS symposium : annual symposium IEEE/LEOS Benelux chapter : November 28, 1996, University of Twente, Enschede, The Netherlands* (pp. 108-111). Twente University.

Document status and date:

Published: 01/01/1996

Document Version:

Publisher's PDF, also known as Version of Record (includes final page, issue and volume numbers)

Please check the document version of this publication:

- A submitted manuscript is the version of the article upon submission and before peer-review. There can be important differences between the submitted version and the official published version of record. People interested in the research are advised to contact the author for the final version of the publication, or visit the DOI to the publisher's website.
- The final author version and the galley proof are versions of the publication after peer review.
- The final published version features the final layout of the paper including the volume, issue and page numbers.

[Link to publication](#)

General rights

Copyright and moral rights for the publications made accessible in the public portal are retained by the authors and/or other copyright owners and it is a condition of accessing publications that users recognise and abide by the legal requirements associated with these rights.

- Users may download and print one copy of any publication from the public portal for the purpose of private study or research.
- You may not further distribute the material or use it for any profit-making activity or commercial gain
- You may freely distribute the URL identifying the publication in the public portal.

If the publication is distributed under the terms of Article 25fa of the Dutch Copyright Act, indicated by the "Taverne" license above, please follow below link for the End User Agreement:

www.tue.nl/taverne

Take down policy

If you believe that this document breaches copyright please contact us at:

openaccess@tue.nl

providing details and we will investigate your claim.

First CAD-tool for simulating complex photonic integrated circuits

X.J.M. Leijtens P. Le Lourec* C.G.M. Vreeburg T. Uitterdijk M.K. Smit

Delft University of Technology, P.O. Box 5031, 2600 GA Delft, The Netherlands

*France Telecom, CNET, Technopole Anticipa, 2 avenue Pierre Marzin, 22307 Lannion, France

A design tool for simulation of complex photonic integrated circuits, based on a professional microwave design system is described. An example simulation of a four-channel add-drop multiplexer is presented. Results are in good agreement with measurements.

Introduction

Computer aided design (CAD) tools for photonic integrated circuits generally initiate the design and simulation based on a layout description of the circuit and use BPM techniques to carry out the simulation. We have chosen to use a more flexible approach initiating the design on a symbolic level and perform the simulation and the generation of the mask layout from that level. The advantage of this approach is that the circuit is better structured and that both BPM and other simulation methods can be implemented for different components or sub circuits. Because photonic integrated circuits are conceptually quite similar to microwave integrated circuits, optical component models for handling propagation and coupling of optical fields have been implemented in a professional microwave design system (Hewlett Packard's MDS) [1].

Description of optical components

The coupling between optical components takes place via guided modes and radiation fields. If coupling through radiation fields is small, optical components can be considered as individual units connected to each other at well defined ports. In this concept, the response of an N -port component is described by its $N \times N$ S -matrix.

An ideal monomode waveguide is a 2-port component. The propagation in a straight waveguide is described by $S_{12} = S_{21} = e^{-j\beta\ell}$, with β the propagation constant and ℓ the length of the waveguide. For a curved waveguide $S_{12} = S_{21} = e^{-j\beta_\phi\phi}$, with β_ϕ the angular propagation constant and ϕ the angle of the curved waveguide. Since there are no reflections in the waveguide, $S_{11} = S_{22} = 0$.

In order to obtain the S matrix, any mode solver calculating the modal propagation constants can be used. The current implementation offers the choice of the effective index method, in combination with a conformal transformation for curved waveguides[2], and a 2D finite element method. A beam propagation method is used for components where coupling through radiation fields plays an important role.

The junction between two monomode waveguides is described by a 2×2 scattering matrix. The matrix elements are given by the overlap integral of the modal fields U_1 and U_2 in each of the waveguides: $S_{12}^* = S_{21} = \int U_1 U_2^*$. As reflections in optical chips are small for many applications, S_{11} and S_{22} are set to zero, although inclusion of reflections is straightforward.

Simulation of phased array demultiplexer

The simulation of a phased array demultiplexer (PHASAR) is performed in two steps. First the geometry of the PHASAR is created with the desired specifications, such as the number

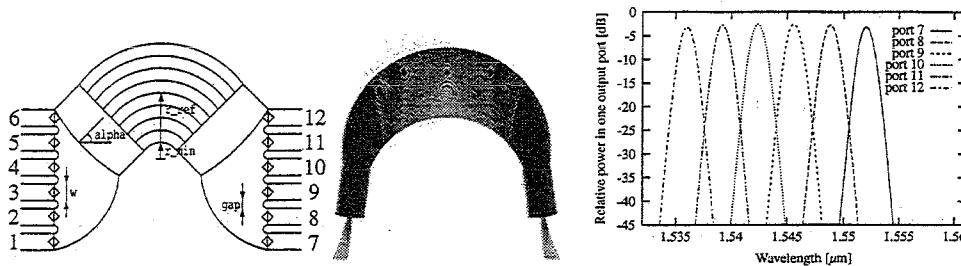

Figure 1: Symbolic representation of a 6×6 PHASAR and the layout generated by this component for the ADM application. The wavelength response of the PHASAR is shown when the signal is launched in input 2.

of input and output ports, the central wavelength and the channel spacing. Secondly, the propagation through this PHASAR is simulated.

The design of the PHASAR geometry is based on the description by Smit [3] and uses two star couplers connected by an array of straight and curved waveguides. A PHASAR with N input and M output waveguides is described by an $(N + M) \times (N + M)$ S -matrix. The matrix elements S_{ij} are calculated in the following way: first the field from port i is diffracted using the Rayleigh-Sommerfeld model [4] and the coupling coefficient with each waveguide of the array is calculated. These coefficients are corrected for coupling between adjacent array waveguides by a normalisation procedure using the super modes of the waveguide array, which are constructed following the description by Chiang [5]. Secondly, the propagation in each waveguide is calculated taking into account the coupling loss at the junctions and the radiation loss in the curved waveguides. Finally, the coupling coefficient between each array waveguide and the diffracted field of output port j is calculated using the same method as for the input ports.

An example of the symbolic representation in MDS of a 6×6 phased array together with the mask layout and the simulated response is shown in figure 1. This PHASAR has a free spectral range of 40 nm and a channel spacing of 400 GHz (3.2 nm). The simulated loss of the phased array is between 2.4 dB and 3 dB.

Simulation of a 4-channel add-drop multiplexer

The four-channel ADM consists of a 6×6 PHASAR (de)multiplexer in loop-back configuration, as reported by Vreeburg [6]. The loop-back paths contain Mach-Zehnder Interferometric switches [7] composed of straight and curved waveguides and two 3 dB MMI couplers [8]. The switches are used to open and close the loops. The symbolic representation of the circuit in MDS is shown in figure 2.

Four wavelengths ($\lambda_1 \dots \lambda_4$) from the input (SOURCE) are demultiplexed by the PHASAR and are routed to the switches (1...4). Each wavelength can be switched to the DROP port (1...4) or back to the PHASAR where the signals are multiplexed into one output port (DETECTOR). If a signal is routed to the DROP port then another signal of the same wavelength can be added at the proper ADD port and will be multiplexed to the output port.

The simulated response of the ADM, when all signals loop back to the phased array is shown in figure 3(a). Four peaks are visible ($\lambda_1 \dots \lambda_4$) and a fifth peak originating from the direct signal from input to output. The simulated loss of the ADM is between 5.5 dB and 6.8 dB.

The simulated response of the ADM when switch 3 is active is presented in figure 3(b).

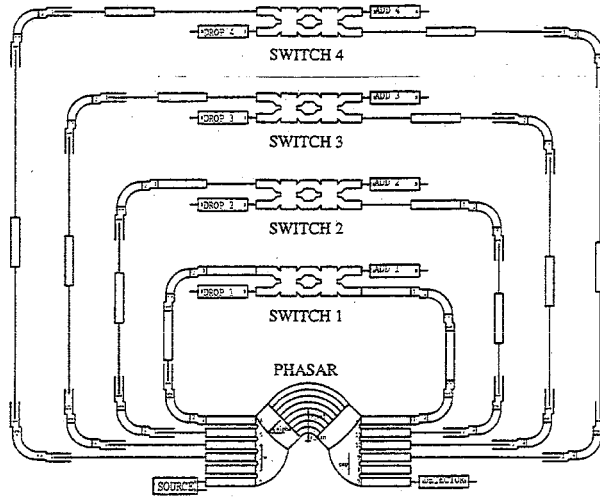

Figure 2: Symbolic representation of the four channel ADM circuit.

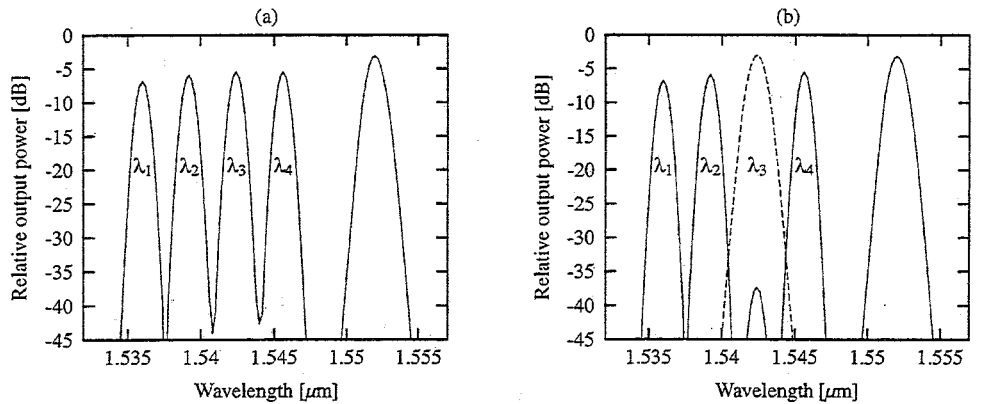

Figure 3: Simulation results of a four channel ADM. (a) Response at the output of the ADM. All switches are in the cross state. (b) Signal at the output of the ADM when switch 3 is in the bar state. The added signal is shown with a dashed line.

The signal going through switch 3 is routed to the DROP port. At the output port, only three channels are present. However, a signal at λ_3 has been added at the proper ADD port (dashed curve in the figure). The peak at this wavelength has a larger width and exhibits a lower loss because the signal traverses the PHASAR only once.

Comparison with measurements

The InP-based four-channel ADM as described here was realized by Vreeburg [6]. The measured responses are presented in figure 4 for all switches in the cross-state (a) and for only switch 3 in the bar state (b). A comparison between simulation and measurement shows a shift in wavelength of $\Delta\lambda = 9$ nm. This is mainly due to a difference between the designed and the fabricated waveguide structure. The measured losses are between 7 dB and 9.1 dB. The simulated losses are less (5.5–6.8 dB) because the simulation does not take into account the loss due to the waveguide crossings (approximately 0.2 dB per crossing). If this is included, the total loss of the circuit is between 6.9 dB and 9 dB, in

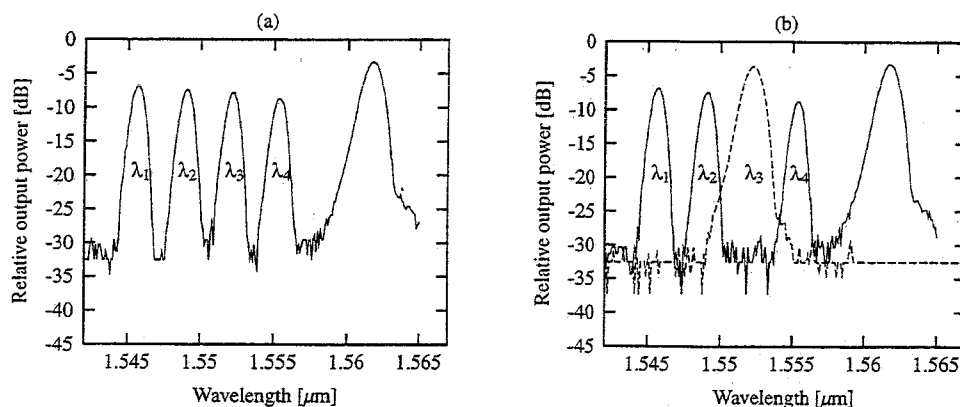

Figure 4: Measurement results of a four channel ADM. (a) Response at the output of the ADM. All switches are in the cross state. (b) Signal at the output of the ADM when switch 3 is in the bar state. The added signal is shown with a dashed line.

good agreement with the measurements. Figure 3(b) shows a residual signal for λ_3 about 30 dB below the original signal. This is due to the extinction ratio of the switch. Measurements on single switches as used in the ADM show an extinction ratio of 22–25 dB, which is not visible in figure 3(b).

Conclusion

An example of an application of a powerful CAD-tool for photonic integrated circuits has been presented. The S -matrix approach enables the simulation of complex circuits, which may contain loops, such as the one analysed in this article. The comparison with measurement demonstrates the validity of the simulations.

References

- [1] X. Leijtens, L. Spiekman, C. van Dam, L. de Vreede, M. Smit, and J. Tauritz, "CAD-tool for integrated optics," in *Proc. 7th Conf. on Integr. Opt. (ECIO '95)*, pp. 463–466, Delft, The Netherlands, April 3–6 1995.
- [2] M. Heiblum and J. H. Harris, "Analysis of curved optical waveguides by conformal transformation," *IEEE J. Quantum Electron.*, vol. QE-11, pp. 75–83, Feb. 1975. with correction QE-12 p.313.
- [3] M. Smit, *Integrated Optics in silicon-based aluminum oxide*. PhD thesis, Delft University of Technology, Delft, The Netherlands, 1991. ISBN 90-9004261-X.
- [4] M. Born and E. Wolf, *Principles of optics*. Pergamon Press, sixth ed., 1993.
- [5] K. S. Chiang, "Effective-index method for the analysis of optical waveguide couplers and arrays: An asymptotic theory," *J. Lightwave Technol.*, vol. 9, pp. 62–72, Jan. 1991.
- [6] C. Vreeburg, T. Uitterdijk, Y. Oei, M. Smit, F. Groen, E. Metaal, P. Demeester, and H. Frankena, "First InP-based reconfigurable integrated add-drop multiplexer," *IEEE Photon. Technol. Lett.*, Submitted July '96.
- [7] T. Uitterdijk, H. van Brug, F. Groen, H. Frankena, C. Vreeburg, and J. van der Tol, "Integrable polarisation insensitive InGaAsP/InP Mach-Zehnder switch," in *Int. Phot. Res. Tech. Dig. (IPR '96)*, pp. 486–489, Opt. Soc. of Am., Apr.29–May 2 1996.
- [8] L. B. Soldano and E. C. M. Pennings, "Optical multi-mode interference devices based on self-imaging: Principles and applications," *J. Lightwave Technol.*, vol. 13, pp. 615–627, Apr. 1995.