

Accuracy analysis of an industrial building system

Citation for published version (APA):

Holický, M., Bats, J. O., & Hoof, van, P. A. J. (1992). *Accuracy analysis of an industrial building system*. (TU Eindhoven. Fac. Bouwkunde, Vakgr. Konstruktie; Vol. TUE-BKO-9223). Technische Universiteit Eindhoven.

Document status and date:

Published: 01/01/1992

Document Version:

Publisher's PDF, also known as Version of Record (includes final page, issue and volume numbers)

Please check the document version of this publication:

- A submitted manuscript is the version of the article upon submission and before peer-review. There can be important differences between the submitted version and the official published version of record. People interested in the research are advised to contact the author for the final version of the publication, or visit the DOI to the publisher's website.
- The final author version and the galley proof are versions of the publication after peer review.
- The final published version features the final layout of the paper including the volume, issue and page numbers.

[Link to publication](#)

General rights

Copyright and moral rights for the publications made accessible in the public portal are retained by the authors and/or other copyright owners and it is a condition of accessing publications that users recognise and abide by the legal requirements associated with these rights.

- Users may download and print one copy of any publication from the public portal for the purpose of private study or research.
- You may not further distribute the material or use it for any profit-making activity or commercial gain
- You may freely distribute the URL identifying the publication in the public portal.

If the publication is distributed under the terms of Article 25fa of the Dutch Copyright Act, indicated by the "Taverne" license above, please follow below link for the End User Agreement:

www.tue.nl/taverne

Take down policy

If you believe that this document breaches copyright please contact us at:

openaccess@tue.nl

providing details and we will investigate your claim.



Faculteit Bouwkunde
Vakgroep
Konstruktie



Technische Universiteit Eindhoven

Accuracy analysis of an
industrial building system

Milan Holický
Jan O.Bats
Peter A.J. van Hoof

October 1992
TUE/BKO/92.23

This report has been prepared at the Technical University of Eindhoven in 1992 during a short stay of Milan Holický, research worker of the Klokner Institute of the Czech Technical University in Prague.

ACCURACY ANALYSIS OF AN INDUSTRIAL BUILDING SYSTEM

Milan Holický, Jan O. Bats and Peter A.J. van Hoof

Summary

The primal aim of submitted accuracy analysis is to assess possible dimensional variations and to indicate necessary measures guaranteeing desired quality of newly developing industrial building system. The decisive quality requirement imposed on the system appears to be the fundamental condition for smooth assembly of prefabricated components without any special mounting equipment and supplementary erection measurements.

Submitted analysis represents the first attempt to investigate dimensional accuracy of the system using statistical concepts and probabilistic models. In view of insufficient statistical information, some input data are, however, only estimated. Nevertheless, the results obtained up to now already allow to draw valuable conclusions and recommendations, which could improve further development and design of the system.

Structural system is firstly analyzed in vertical direction considering three representative assemblies, then in horizontal direction using two basic assemblies. Furthermore, dowel connections of wall and floor components are investigated and finally important assembly of shear walls is examined. Load bearing components, infill components and both vertical and horizontal coupling strips interconnecting adjacent structural components are considered.

Analysis of selected assemblies shows that both deviations, induced by manufacturing, setting out and erection, and inevitable deformations of its components, due to loads, are to be taken into account when analyzing dimensional accuracy of the system. It is shown that deviations and deformations may be accommodated in some structural joints and consequently may cause assembling problems. Important conclusions and practical recommendations concerning designed sizes are proposed for considered components and their parts, as well as for applied erection procedures. Generally it is recommended to use technique of positional redundant erection whenever possible and to apply overlapping rather than face contact joints.

Further research should be focused on systematic evaluation of relevant statistical data for actual deviations and deformations of various bearing and infill components. Results of desired control measurements and detail structural analysis, supplemented by practical experiences from the experimental structures, should enable a refined analysis and, if necessary, additional investigations of other assemblies, including cladding components and secondary elements of the developing building system.

ACCURACY ANALYSIS

of an industrial building system

Contents	page number in Sections	total
Summary		2
Contents		3
1 Introduction	1 - 1	5
2 General principles	2 - 1	7
2.1 Accuracy characteristics	2 - 1	7
2.2 Accuracy conditions	2 - 4	10
2.3 Theoretical models	2 - 5	11
2.4 Analysis principles	2 - 7	13
2.5 Flow chart of accuracy analysis	2 - 8	14
2.5 Conclusions	2 - 9	15
3 Vertical assemblies	3 - 1	16
3.1 Structural height	3 - 1	16
3.1.1 Representative assembly	3 - 1	16
3.1.2 Theoretical model	3 - 2	17
3.1.3 Analysis	3 - 3	18
3.1.4 Conclusions and recommendations	3 - 6	21
3.2 Infill components	3 - 7	22
3.2.1 Representative assembly	3 - 7	22
3.2.2 Theoretical model	3 - 7	22
3.2.3 Analysis	3 - 8	23
3.2.4 Conclusions and recommendations	3 - 11	26
3.3 Vertical coupling strips	3 - 12	27
3.3.1 Representative assembly	3 - 12	28
3.3.2 Theoretical model	3 - 14	29
3.3.3 Analysis	3 - 15	30
3.3.4 Conclusions and recommendations	3 - 17	32

4	Horizontal assemblies	4 - 1	33
	4.1 Floor components	4 - 1	33
	4.1.1 Representative assembly	4 - 1	33
	4.1.2 Theoretical model	4 - 3	35
	4.1.3 Analysis	4 - 4	36
	4.1.4 Conclusions and recommendations	4 - 8	40
	4.2 Horizontal coupling strips	4 - 9	41
	4.2.1 Representative assembly	4 - 9	41
	4.2.2 Theoretical model	4 - 11	43
	4.2.3 Analysis	4 - 13	45
	4.2.4 Conclusions and recommendations	4 - 15	47
5	Dowel connections	5 - 1	48
	5.1 Vertical components	5 - 1	48
	5.1.1 Representative assembly	5 - 1	48
	5.1.2 Theoretical model	5 - 2	49
	5.1.3 Analysis	5 - 3	50
	5.1.4 Conclusions and recommendation	5 - 4	51
	5.2 Horizontal components	5 - 5	52
	5.2.1 Representative assembly	5 - 5	52
	5.2.2 Theoretical model	5 - 7	54
	5.2.3 Analysis	5 - 7	54
	5.2.4 Conclusions and recommendation	5 - 9	56
6	Shear walls	6 - 1	57
	6.1 Representative assembly	6 - 1	57
	6.2 Theoretical model	6 - 2	58
	6.3 Analysis	6 - 4	60
	6.4 Conclusions and recommendations	6 - 6	62
7	Conclusions	7 - 1	63
	References		65
	List of Figures		66
	List of Tables		67

1 INTRODUCTION

Dimensional accuracy is an important quality indicator of all assembled building structures and other civil engineering works. Geometrical inaccuracies of various bearing and infill elements, induced by manufacturing, setting out and erection or caused by their deformations due to load and other actions may unfavourably affect compliance with various functional requirements imposed on the structural system including conditions for smooth assembling of prefabricated components. Obviously unintended induced deviations as well as inevitable deformations could lead to malfunctions of a structural system, to undesired increase of assembling time and additional construction, maintenance and service costs [1].

All this is particularly valid for newly developing industrial building system [2] based on small number of different, demountable prefabricated components suitable for mass production and repeatable application. Moreover, proposed connections and joints of its structural parts and components require relatively high precision of all involved construction processes to comply with relevant functional requirements including smooth erection of prefabricated components and their proper attachment to the remaining parts of a structure. That is why accuracy analysis seems to be an extremely important part of entire design of the industrial building system.

Submitted report represents, however, the first attempt to investigate dimensional accuracy of the industrial building system using mathematical models and consequently it is far from being complete to answer all possible accuracy questions. Practical experience may show that, besides considered assemblies, there are other structural joints and details, which should be investigated additionally.

Structural system is firstly investigated in vertical and horizontal directions separately, then dowel connections of vertical and horizontal components are analyzed and finally in case of shear walls both dimensions are taken into account. As relevant measurements and practical experiences with the investigated structure are very limited, input data considered in the following analyses are mostly estimated. That being the case, included numerical examples are consistently based on two sets of accuracy characteristics corresponding to lower and higher accuracy of production processes. The aim of this precaution is not only to overcome lack of information on relevant input data, but also to demonstrate more comprehensively

1 Introduction

sensitivity of resulting accuracy to uncertain input data. Generally data specified for higher accuracy are those accepted for design documentation.

It is therefore expected, that revised accuracy analyses will be performed whenever new data and experiences are available. A research project systematically evaluating control measurements of actual induced deviations (manufacturing of components, setting out and erection) as well as to expected structural deformations (due to loads at various construction and service stages) would be extremely useful. Results of this project supplemented by practical experiences will best indicate demands for further analysis including modification of applied theoretical models and investigation of new structural assemblies.

The following Section 2 introduces general principles of accuracy analysis, which are then applied to investigate dimensional accuracy of the industrial building system. Section 3 contains analyses of characteristic vertical assemblies, Section 4 is devoted to horizontal assemblies, Section 5 to dowel connections and Section 6 to an important assembly of shear walls. Each of these Sections includes practical conclusions and recommendations concerning investigated assemblies. The last Section 7 offers general conclusions and recommendations including most important results of the analysis and some general guidance for measurements and further investigation of dimensional accuracy of the industrial building system.

2 GENERAL PRINCIPLES

2.1 Accuracy characteristics

Two independent sources of dimensional changes, indicated in Fig 2.1, are to be generally considered when analyzing dimensional accuracy of building structure and other civil engineering works:

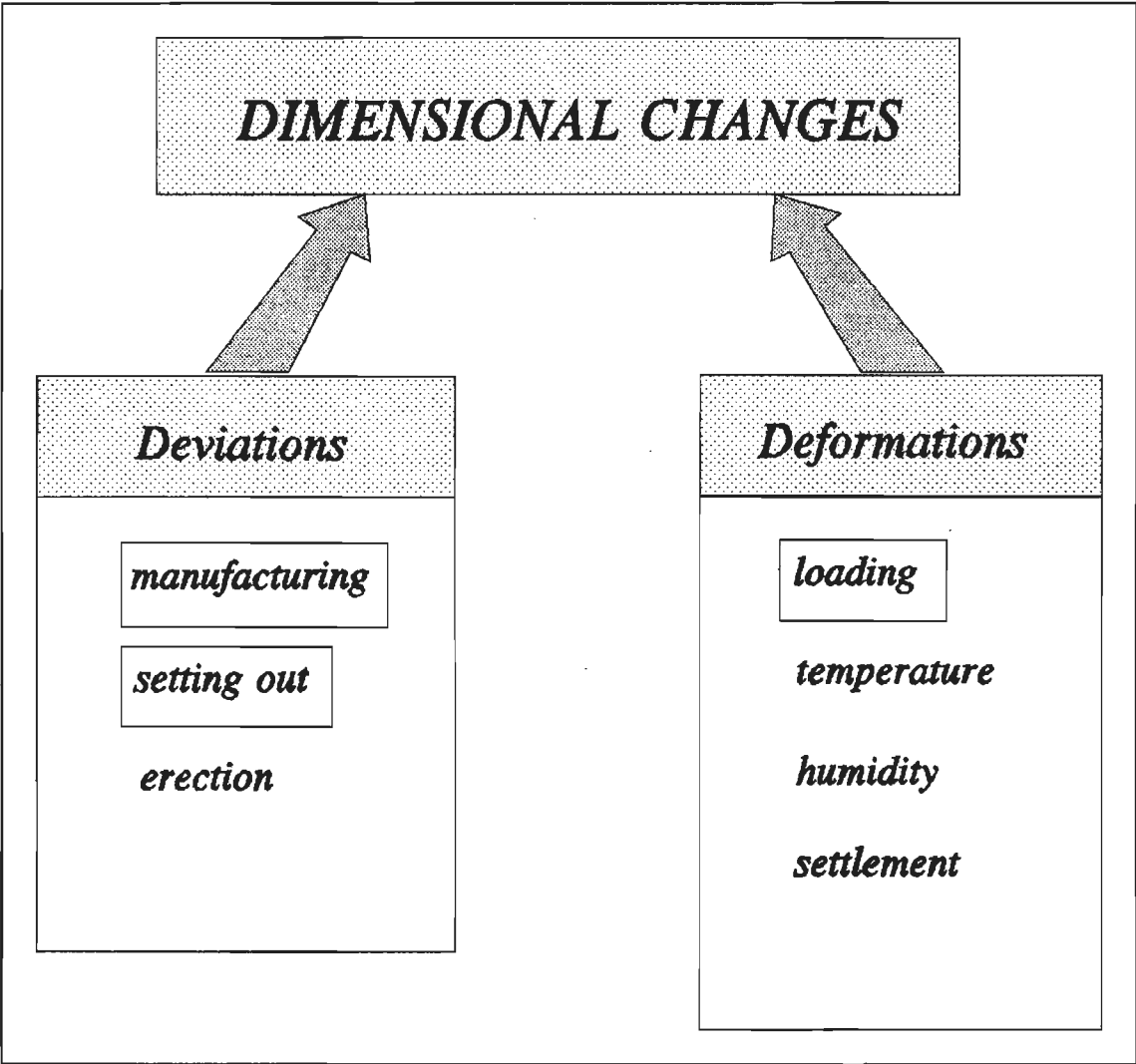

Fig. 2.1 Sources of dimensional changes

2 General principles

- deviations, called also induced deviations, due to setting out, manufacturing and erection,

- deformations, called also inherent deviations, due to various physical and chemical causes including loads.

Comprehensive description of all relevant accuracy characteristics of deviations and deformations used for assessment of dimensional variation of building structures is given in [1]. Relevant principles to analyzed industrial housing system are reformulated in this Section. Although expected dimensional variations of the considered housing system are mostly caused by induced deviations, in some assemblies effects of deformations due to loading may be equally significant.

Basic accuracy characteristics describing deviations are demonstrated in Fig. 2.2.

The fundamental characteristic of a dimension x is the reference size x_R , which is the nominal or target size specified in the design documentations and to which all kinds of deviations and deformations are related. It is a time independent value determined for modular and structural requirements only, without taking into account any kind of deviations and deformations.

It is usually assumed [1], that induced deviations as well as deformations of a dimension x have symmetrical probability distribution with the mean x_c , which may generally differ from the reference size by a systematic deviation δx_c . Random components of the time independent induced deviations are expressed by the limit deviation δx corresponding to certain fractiles of the distribution as indicated in Fig 2.2.

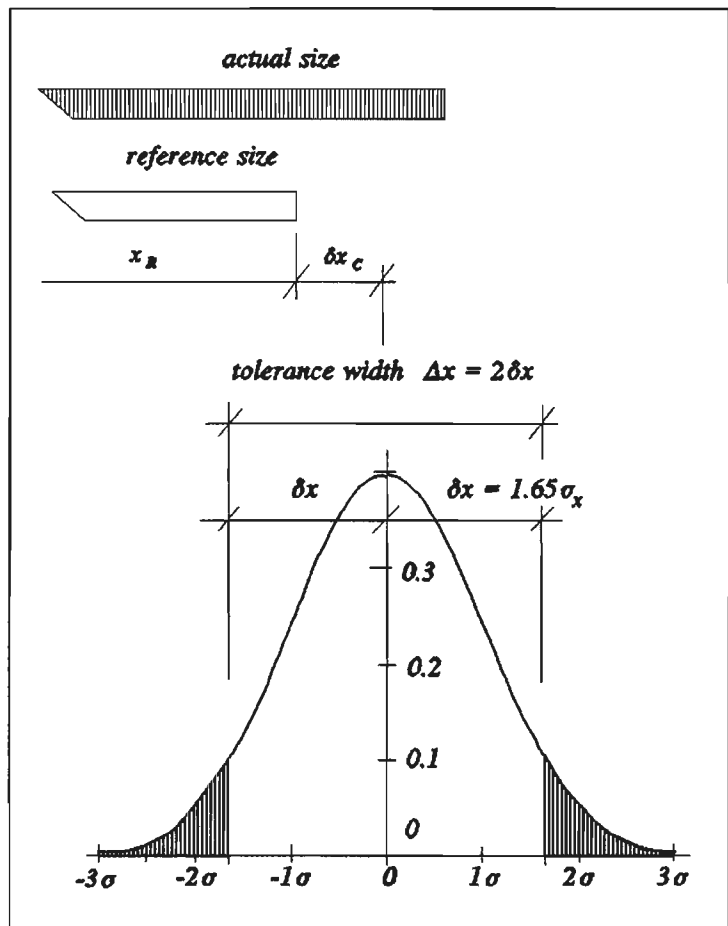

Fig. 2.2 Accuracy characteristics

corresponding to certain fractiles of the distribution as indicated in Fig 2.2.

The same assumption concerning probability distribution is accepted for deformations. To distinguish deformations from deviations, symbol ϵ is used instead of δ . However, deformations are generally time dependent quantities, which always correspond

2 General principles

to certain reference physical conditions describing temperature, humidity, loading, etc. Relevant characteristics of time dependent deformations can be usually sufficiently well determined from these conditions using appropriate mechanical models and can be represented by appropriate deterministic and random components.

Random component of deformations should correspond to the same probability of exceeding the limit values as in the case of induced deviations. The following analyses and calculations are, however, independent of the value of that probability, as long as the same probability (say 5%) is considered for all involved dimensions. On the other hand, accepted value of this probability is important for correct interpretation of specified characteristics and their control.

Three distinct combinations of reference physical conditions and corresponding deformations are particularly significant:

- the initial conditions at the manufacturing stage, which cause by definition zero deformations,
- the assembly conditions at the assembly or erection stage, which cause the systematic assembly deformation ϵx_c from the initial size $x_c = x_R + \delta x_c$ and its random component ϵx ,
- the extreme service conditions, which may occur over the whole period of service time, and which cause the extreme deformation increments from the assembly size $x_R + \delta x_c + \epsilon x_c$; the minimum systematic increment within the service time is denoted ϵx_c^- , the maximum systematic increment is denoted ϵx_c^+ and respective random components ϵx^- and ϵx^+ .

The systematic induced deviation δx_c and the deformation at the assembly stage result in the total systematic deviation

$$\tau x_c = \delta x_c + \epsilon x_c$$

It may be generally assumed that induced deviations and deformations are mutually independent quantities and their random components may be combined in accordance with the statistical rules as

$$\tau^2 x = \delta^2 x + \epsilon^2 x,$$

$$\tau^2 x^- = \delta^2 x + \epsilon^2 x^-,$$

$$\tau^2 x^+ = \delta^2 x + \epsilon^2 x^+,$$

where τx , τx^- and τx^+ represent the total limit deviations at assembly and service stages including effects of both the induced deviations and deformations.

The extreme values of the dimension x , the lower limit size x_L and the upper limit size x_U at assembly stage are then given as

$$x_L = x_R + \tau x_c - \tau x,$$

2 General principles

$$x_{\text{y}} = x_{\text{R}} + \tau x_{\text{c}} + \tau x.$$

Similarly, for extremes at service stage it holds

$$x_{\text{L}} = x_{\text{R}} + \tau x_{\text{c}} + \epsilon x_{\text{c}}^{-} - \tau x^{-},$$

$$x_{\text{y}} = x_{\text{R}} + \tau x_{\text{c}} + \epsilon x_{\text{c}}^{+} + \tau x^{+}.$$

The lower limit size x_{L} and the upper limit size x_{y} may be sometimes more conveniently expressed in terms of the lower limit deviation τx_{L} and the upper limit deviation τx_{y} from the reference size x_{R} , given for assembly and extreme service stages as

$$\tau x_{\text{L}} = \tau x_{\text{c}} - \tau x,$$

$$\tau x_{\text{y}} = \tau x_{\text{c}} + \tau x,$$

$$\tau x_{\text{L}} = \tau x_{\text{c}} + \epsilon x_{\text{c}}^{-} - \tau x^{-},$$

$$\tau x_{\text{y}} = \tau x_{\text{c}} + \epsilon x_{\text{c}}^{+} + \tau x^{+}.$$

Accuracy analyses is considerably simplified when all components of deformations $\epsilon x_{\text{c}}^{+}$, $\epsilon x_{\text{c}}^{-}$, $\epsilon x_{\text{c}}^{+}$, ϵx^{-} and ϵx^{+} may be neglected. This is the most frequent case of accuracy analyses, which will be accepted in majority of assemblies investigated bellow. Then the lower and upper limit sizes and the lower and upper limit deviations follow from the above relationships as

$$x_{\text{L}} = x_{\text{R}} + \delta x_{\text{c}} - \delta x,$$

$$x_{\text{y}} = x_{\text{R}} + \delta x_{\text{c}} + \delta x,$$

$$\delta x_{\text{L}} = \delta x_{\text{c}} - \delta x,$$

$$\delta x_{\text{y}} = \delta x_{\text{c}} + \delta x.$$

When, furthermore, the systematic deviation δx_{c} vanishes, then the lower limit deviation δx_{L} is equal to $-\delta x$ and the upper limit deviation δx_{y} is equal to δx . In that case well known expression $x_{\text{R}} \pm \delta x$ is traditionally used. In the following analyses accuracy characteristics will be mostly expressed in terms of the systematic deviations δx_{c} and limit deviations δx .

2.2 Accuracy conditions

The functional requirements imposed on the structure cover all kinds of safety, serviceability and other requirements including construction, physical and visual aspects. Taking into account all these requirements the functional lower limit x_{Lf} and the functional upper limit x_{yf} for a dimension x , are to be specified. These time independent quantities correspond to a given degree of certainty that the relevant requirements are com-

2 General principles

plied with, if they are not exceeded within a specified life time of the structure. To verify the compliance with the functional requirements, the following accuracy conditions are to be fulfilled

$$x_L \geq x_{Lf},$$

$$x_{\eta} \leq x_{\eta f},$$

where the left-hand side quantities x_L and x_{η} are given by the appropriate equations given in previous Section.

In terms of limit deviations the accuracy conditions may be written as

$$\tau x_L \geq \tau x_{Lf},$$

$$\tau x_{\eta} \leq \tau x_{\eta f}.$$

The accuracy conditions should be satisfied for all relevant (critical) dimensions describing geometrical accuracy of a structure. For some dimensions (called constituent dimensions - see next section) such a verification can be done easily by comparing given accuracy characteristics with the functional limits. For other dimensions (called resultant dimensions - see next section) accuracy characteristics must be first derived from characteristics of other (constituent) dimensions.

Analysis of structural serviceability of assembled structures is to be generally performed for both the assembly and service stages. The resulting recommendations concerning dimensional characteristics of a structure are then outcomes of calculations for both stages [1]. For demountable structures, which is the case of the investigated industrial housing system, the accuracy characteristics at the assembly stage must include possible time dependent effects of deformations occurring during previous service of the structure. However, when the deformations are negligible, the accuracy analysis is to be performed for assembly stage only.

2.3 Theoretical models

To analyze the dimensional accuracy of a structure, the functional requirements and appropriate functional limits for all the relevant dimensions must be first carefully specified. Furthermore, detailed construction techniques, production and erection procedures, the shape of the components, the setting out system and other circumstances possibly affecting the resulting accuracy should be considered. Then it is usually possible to identify representative assemblies whose accuracy may be analyzed independently of the remaining parts of the structures. This assemblies must enable to fulfil the aim of the analysis, i.e. to specify all the necessary measures to comply with the

2 General principles

functional requirements imposed on the structure. The graphical representation of an assembly is called a design scheme.

Taking into account all given construction procedures, including setting out, production and erection technique, all dimensions describing representative assemblies at assembly stage are intentionally divided into two basic groups:

- constituent dimensions x_i , $i = 1, 2, \dots, n$.
- resultant dimensions y_i , $i = 1, 2, \dots, m$.

This classification is related to the assembly stage, on which the entire analysis is always based. As already indicated, when deformations are to be considered, accuracy analysis at service stage must be performed to supplement the results of the calculation at assembly stage. The basic classification of all dimensions from assembly stage remains valid also for service stage.

Constituent dimensions are those dimensions, whose accuracy characteristics are known beforehand with respect to the assembly operations. Generally there are three kinds of constituent dimensions:

- dimensions of components or structural elements,
- setting out and measured distances,
- distances checked by erection.

As a rule constituent dimensions are statistically independent random variables.

Resultant dimensions characterize the result of assembly and therefore are dependent on constituent dimensions. Accuracy characteristics of resultant dimensions are not known beforehand and must be derived from characteristics of constituent dimensions. Some of the resultant dimensions are statistically dependent random variables: either they are dependent on the same constituent dimensions, or some of them (often just two) are mutually checked and adjusted by erections. The latter dimensions are called controlled dimensions and their statistical dependence can not be avoided and must be taken into account in the calculation using their correlation coefficients. Mutual dependence of the other resultant dimensions need not be taken into account as long as they enter relationships. The resulting dimensions can be therefore divided in two groups:

- controlled resultant dimensions,
- remaining resultant dimensions.

It should be noted that statistical dependence of various constituent and resultant dimensions is one of the most important factors affecting results of accuracy analyses. This is the reason why all the dimensions are split into the constituent and resultant dimensions and further rules for mathematical treatment

2 General principles

of derived relationships, given in the following text, are introduced.

2.4 Analysis principles

The fundamental step to be taken in an accuracy analysis is a formulation of basic equations, i.e. the mathematical links between the constituent dimensions x_i and resultant dimensions y_k at assembly stage. It should be noted that the entire analysis is based on the assembly stage and, if necessary, supplemented by the calculation at the service stage. Although the basic equations for both stages may be different, the following general rules are valid for both calculations.

The first, very important rule, concerns separation of resultant and constituting dimensions. According to that separation rule the resulting dimensions y_k should be entered on the left-hand side while the constituent dimensions should be entered on the right-hand side of the basic equations. This practice enable to simplify further statistical treatment of the basic equations, because mutually dependent dimensions can be considered separately.

The most frequently encountered basic equation has the following linear form

$$y_k = \sum c_i x_i,$$

where c_i denotes deterministic coefficients expressing geometric relationships between the involved dimensions y_k and x_i . In this case the accuracy characteristics of resultant dimensions are given as

$$\tau y_k = \sum c_i \tau x_{i0},$$

$$\tau^2 y_k = \sum c_i^2 \tau^2 x_i + 2 \sum r_{i1, i2} \tau x_{i1} \tau x_{i2}, \quad i < j,$$

where $r_{i1, i2}$ denotes the correlation coefficient of the constituent dimensions indicated in the subscript.

When controlled resultant dimensions are to be considered, a linear combination of these dimensions appears on the left-hand side of the basic equation. Often, only sum of two controlled resultant dimensions y_1 and y_2 is expressed as a linear combination of constituent dimensions x_i

$$y_1 + y_2 = \sum c_i x_i.$$

Then the accuracy characteristics of controlled resultant dimensions y_1 and y_2 are determinate from the following relationships

$$\tau y_{10} + \tau y_{20} = \sum c_i \tau x_{i0},$$

$$\tau^2 y_1 + \tau^2 y_2 + 2r_{y_1, y_2} \tau y_{10} \tau y_{20} = \sum c_i^2 \tau^2 x_i + 2 \sum r_{i1, i2} \tau x_{i1} \tau x_{i2}, \quad i < j.$$

2 General principles

where r_{y_1, y_2} denotes the correlation coefficient of the controlled resultant dimensions y_1 and y_2 and r_{x_i, x_j} denotes the correlation coefficient of the constituent dimensions x_i and x_j indicated in the subscript.

When deformations may be neglected (at least at certain stages) and only induced deviations are considered, then instead of the total deviations, denoted by symbol τ , induced deviations, for which traditionally symbol δ is used, are to be entered in the above general equations. This case occurs in many assemblies analyzed bellow.

Relationships between resulting and constituent dimensions at service stage are usually very simple and may be generally described by the first type of basic equation. The characteristics of resultant dimensions may be then expressed as

$$\begin{aligned}\epsilon y_{i^t} &= \sum c_i \epsilon x_{i^t}, \\ \epsilon^2 y_{i^t} &= \sum c_i^2 \epsilon^2 x_{i^t},\end{aligned}$$

The combination of the signs \pm in the relationship for the deformation increments ϵy_{i^t} must be always adjusted in accordance with the signs of the coefficients c_i , which is usually obvious from the concrete form of the appropriate basic equation at service stage [1].

2.5 Flow chart of accuracy analysis

Accuracy characteristics of resultant dimensions are used to verify accuracy conditions described in section 2.2. If these conditions are not satisfied, some input accuracy characteristics of constituent dimensions or specified functional limits for resulting dimensions are to be adjusted and calculation is to be repeated. Flow chart of the entire accuracy analysis, which is applied in the following investigation of dimensional accuracy of industrial housing, is illustrated in Fig. 2.3. In accordance with the concrete structural systems, some process blocks could be purposefully combined into a large blocks as indicated in Fig 2.3.

In the subsequent analyses of dimensional accuracy of the industrial housing system, the whole text is separated into the following main Sections, corresponding to combined process blocks of the flow chart shown in Fig. 2.3:

- Representative assembly.
- Theoretical model.
- Analysis.
- Conclusions and recommendations.

2.6 Conclusions

The most important principles, to be respected when analyzing dimensional accuracy of the industrial housing system, could be highlighted by the following key points.

A - Both, time independent deviations as well as time dependent deformations may simultaneously contribute to the resulting deviations of structural dimensions from their nominal (target) sizes.

B - Any accuracy analysis should be based on foregoing investigation of considered functional requirements and all the circumstances possibly affecting the resulting dimensional accuracy.

C - Based on the above mentioned information, appropriate representative assemblies, whose accuracy may be analyzed independently of the remaining parts of the structures, must be clearly identified.

D - To analyze dimensional accuracy of an assembly it is necessary to distinguish clearly between constituent and resultant dimensions and to formulate rigorously their relationships called basic equations.

E - Derived accuracy characteristics of resultant dimensions must be always related to accepted input data and used theoretical model describing geometrical accuracy of the analyzed representative assembly.

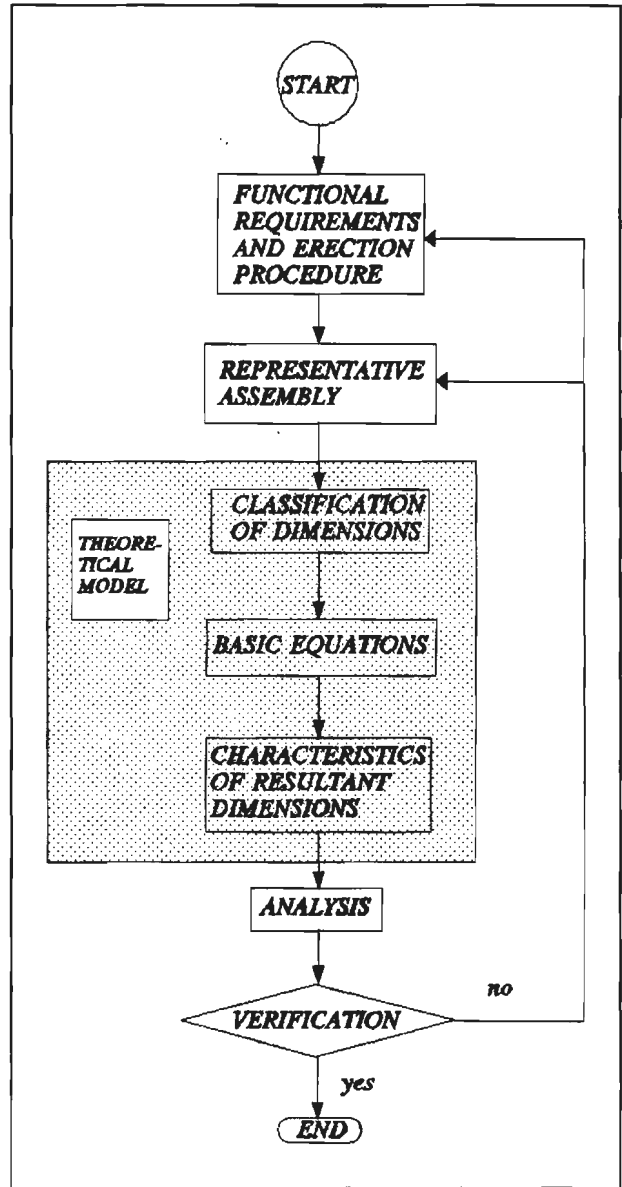

Fig. 2.3 Flow chart

3 VERTICAL ASSEMBLIES

3.1 Structural height

3.1.1 Representative assembly

A typical vertical assembly of prefabricated components of the analyzed structural system is indicated in simplified way by representative assembly in Fig.3.1. The initial ground elevation e_0 of the top surface of the first hat profile is set out and when the profile is fixed, the short wall components of the height h_0 are erected. Then a new hat profile is fixed on the heads of the short components and the level of the first floor l_1 is reached by the top surface of this hat. The same procedure is applied in the following floors, but then vertical components of the full heights h_i , where $i = 1, 2, 3, 4$, are used, as indicated in the Fig 3.1.

The joints between the vertical component bottoms and top surfaces of the lower hat profiles, which are denoted a_i , and joints between the component heads and lower surfaces of the upper hat profiles, denoted a'_i , should be theoretically of zero thickness. These quantities are nevertheless introduced to take account possible deviations from the precise shape of hats profiles, indicated in Fig. 3.2, which may not allow full contacts with corresponding surfaces of wall components. This unintended gaps may arise also due to various imperfections of the relevant surfaces of walls.

Besides the initial measurements of the level e_0 no control measurements are proposed to be done during erection of the structure. It is also expected that vertical tie strips in between two

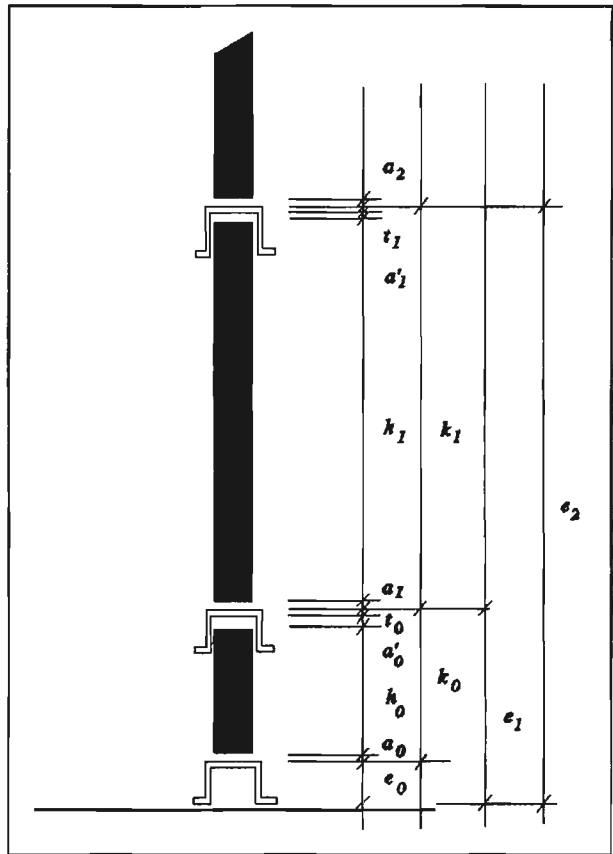

Fig. 3.1 Vertical assembly of wall components.

3 Vertical assemblies

adjacent stories will partly guarantee the correct storey heights. However, the problem of coincidence of the holes in the side segments of the wall components and holes in the strips, which should be used to tighten the wall components of two adjacent floors by the bolts, should be a subject of further investigations. Obviously measurements of actual shapes of all involved components would constitute very important input for such an investigation.

Induced deviations are considered in the following analysis only. It is therefore assumed that no significant deformations occur before or after erection of a structure. However there may be some influences of hat or wall deformations due to vertical loading, which could alter accuracy characteristics of gap dimensions a and a' , especially in lower floors. Input data considered below should be therefore checked and possibly corrected in view of control measurements or any new practical experience. Deformations of actual shape of hat profiles and/or wall components may play significant role in an accuracy analysis of assemblies of infill and cladding components.

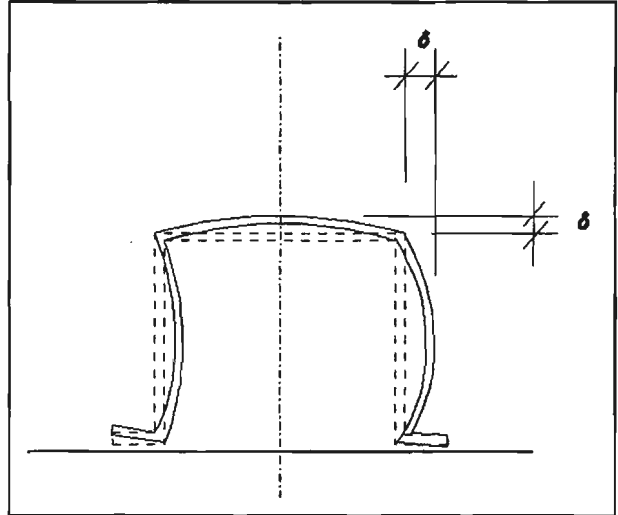

Fig. 3.2 Possible deviations of a hat profile.

Input accuracy data considered below represent only estimates made without any control measurements or experience from completed structures. It is expected that revised analyses will be performed whenever new input data are available. Derived general relationships should be used unless new experiences will show necessity to analyze new representative assemblies. If not specified otherwise all numerical data are given in millimetres.

3.1.2 Theoretical model

Classification of dimensions

From the above description of the erection procedure and from Fig. 3.1, the following classification of all involved dimensions and corresponding basic equations may be derived using principles described in the previous Sections 2.2 and 2.3.

Constituent dimensions: a_i , a'_i , h_i , t_i , ($i = 0, 1, 2, 3, 4$), e_0 ; all independent.

3 Vertical assemblies

Resultant dimensions: k_i ($i = 0, 1, 2, 3, 4$), e_i ($i = 1, 2, 3, 4$); all independent.

Basic equations:

$$k_i = a_i + h_i + a'_i + t_i, \quad (i = 0, 1, 2, 3, 4),$$

$$e_i = e_{i-1} + k_{i-1}, \quad (i = 1, 2, 3, 4, 5).$$

Equations for accuracy characteristics

Equations for systematic and limit deviations follow from the above basic equations and general principles described in Section 2.

Systematic deviations:

$$\delta k_{ic} = \delta a_{ic} + \delta h_{ic} + \delta a'_{ic} + \delta t_{ic}, \quad (i = 0, 1, 2, 3, 4),$$

$$\delta l_{ic} = \delta l_{i-1,c} + \delta k_{i-1,c}, \quad (i = 1, 2, 3, 4, 5).$$

Limit deviations:

$$\delta^2 k_i = \delta^2 a_i + \delta^2 h_i + \delta^2 a'_i + \delta^2 t_i, \quad (i = 0, 1, 2, 3, 4)$$

$$\delta^2 l_i = \delta^2 l_{i-1} + \delta^2 k_{i-1}, \quad (i = 1, 2, 3, 4, 5).$$

3.1.3 Analysis

To determine accuracy characteristics of resultant dimensions two sets of input data for constituent dimensions are considered in the following analysis. First, the data estimated for expected lower level of accuracy of production, second the data estimated for the higher level of accuracy. As already indicated above, these two estimates are made to show effect of accuracy of constituent dimensions on outcome accuracy of resultant dimensions and, at the same time, to indicate possible range of practically obtainable level of accuracy. It is expected that actual accuracy of production would fall within the considered lower and higher estimates. Systematic deviations δx_c and limit deviations δx are considered only, and it is assumed that reference sizes of all constituent and resultant dimensions automatically satisfy basic equation.

It should be noted, that both sets of assumed accuracy characteristics given in Table 3.1, require relatively high accuracy of production and should be verified by results of control measurements and practical experience. This note concerns all constituent dimensions, especially the "gap" thicknesses a_i and a'_i , which could have considerably different

3 Vertical assemblies

accuracy characteristics (in both ways) figured above. As already indicated in previous section both sets of input data represent only estimates and it is expected that revised analyses will be done whenever more accurate input data or new practical experience are available.

Table 3.1 Accuracy characteristics of constituent dimensions.

Dimensions	Accuracy	
	lower	higher
a_i, a'_i	1.0 ± 1.0	0.5 ± 0.5
h_i	0.0 ± 2.0	0.0 ± 1.0
t_j	0.0 ± 0.0	0.0 ± 0.0
e_j	0.0 ± 2.0	0.0 ± 1.0

Accuracy characteristics of resultant dimensions follow from equations derived in previous section in accordance with general principles described in Section 2. Resulting values determinate by simple calculation using input data for lower and higher accuracy of production constituent dimensions given in Table 3.1, are presented in Table 3.2. Again, systematic and limit deviations are considered only. As mentioned above it is assumed that reference sizes of constituent and resultant dimensions satisfy basic equations automatically by design specifications.

Table 3.2 Accuracy characteristics of resultant dimensions.

Dimensions	Accuracy	
	lower	higher
k_i	2.0 ± 2.4	1.0 ± 1.2
e_1	2.0 ± 3.2	1.0 ± 1.6
e_2	4.0 ± 4.0	2.0 ± 2.0
e_3	8.0 ± 4.7	3.0 ± 2.3
e_4	8.0 ± 5.3	4.0 ± 2.6
e_5	10.0 ± 5.8	5.0 ± 2.9

The resulting limit deviations given in Table 3.2 are indicated as functions of the structural elevation in Fig.3.3. The results for the lower accuracy are shown by dashed lines, the

3 Vertical assemblies

results for higher accuracy are presented by full lines. It is obvious, that both accuracy levels would lead to the systematic increase of each storey by approximately 1 or 2 mm, which would inevitably cause overall increase of the building size. The limit deviations of the elevation e_i increases with the number of storeys and at the level of ceiling above the fourth storey they may be as high as 2.9 mm for higher accuracy and 5.8 mm for lower accuracy of production.

The resulting lower and upper limit deviations of the total height of four storeys structure from its reference size could be within broad limits from -1.2 mm at the elevation of the first floor and lower accuracy of production, and 15.8 mm in case of floor above the fourth floor and lower level of accuracy of production. This alarming values may have serious unfavourable

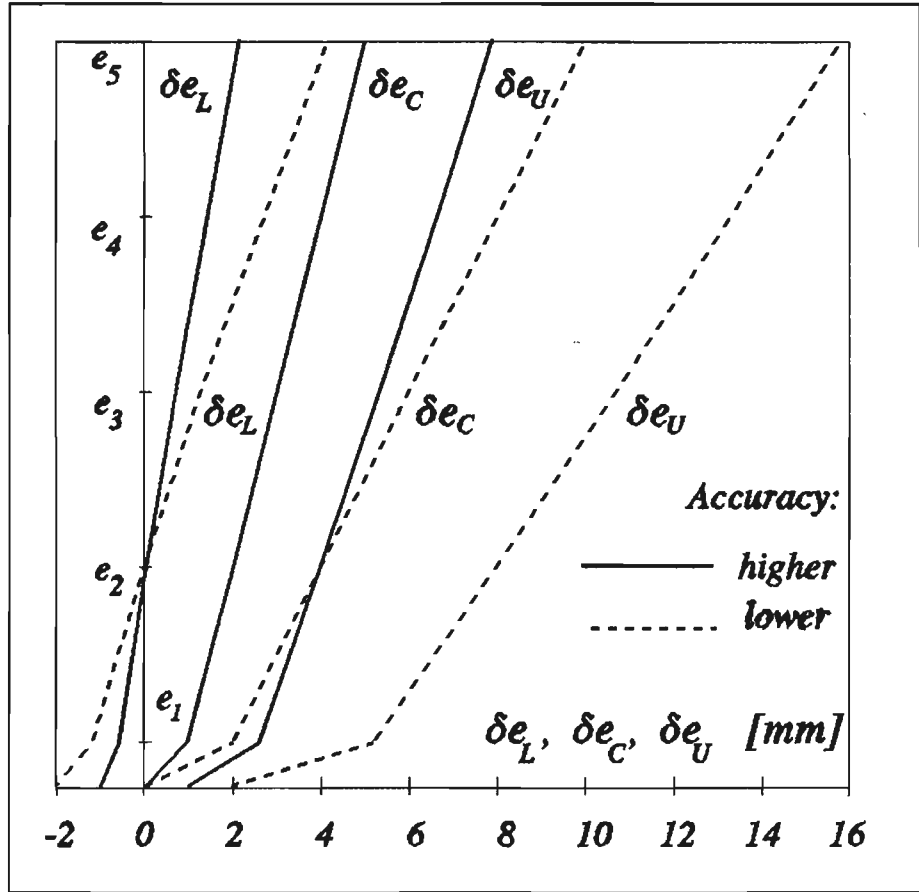

Fig. 3.3 Deviations of floor elevations.

consequences for construction requirements guaranteeing smooth erection of adjacent components and structural elements.

It should be however notified once more, that both sets of input data represent only reasonable estimates and may not reflect the best description of the actual dimensional deviations. Control measurements of geometrical accuracy of all construction processes would be extremely valuable for further improvement of the analyses. In case of analyzed vertical assembly, application of new more realistic input data for the revised calculation, using general relationships derived above, seems to be straightforward easy task.

3.5 Conclusions and recommendations

The following conclusions and recommendations may be drawn from the above analysis.

- A - The actual height of each storey may increase by 1 to 2 mm according to actual accuracy of production.
- B - Limit deviations of each storey height may be expected within the interval from 1.2 mm to 2.4 mm.
- C - The extreme value of lower limit deviation of structural height -1.2 mm, which holds for the higher accuracy and elevation of the first floor, the extreme upper limit deviation is 15.8 mm, which holds for the level of floor above the fourth floor.
- D - It is recommended to shorten the height of the wall components by 1 or 2 mm according to actual accuracy of production to allow for unintended gaps between components.
- E - More accuracy data are desired on actual deviation of setting out and component dimensions in vertical direction.

3.2 Infill components

3.2.1 Representative assembly

A vertical assembly of infill walls components erected into the completed bearing structure of vertical and horizontal members is shown in Fig. 3.4.

Wall components of the height h_w are erected into the opening between two hat profiles, which is given by their vertical distance k and height of the top hat h_h . The distance k is furthermore dependent on the storey height k_i , analyzed in Section 3.1, and on deformations of both hat profiles.

Due to various imperfections and partly also due to the deflection of hat profiles, there may be a gap of the thickness a between the infill wall components supporting lower hat profile. At the top of wall components a joint of thickness b should have sufficiently great size to accommodate dimensional imperfections as well as deflection of upper hat profiles.

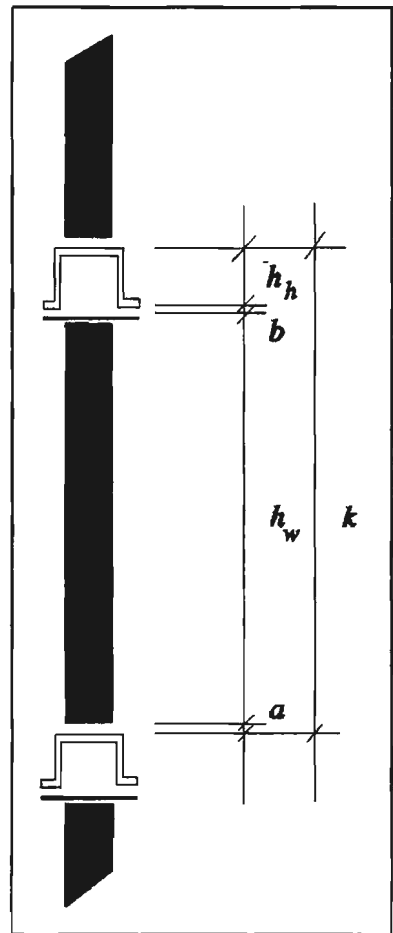

Fig, 3.4. Infill component

3.2.2 Theoretical model

Classification of dimensions

Constituent dimensions: k, a, h_h, h_w .

Resultant dimension: b .

Basic equation

$$b = k - a - h_h - h_w.$$

Equations for characteristics of the resultant dimension

Systematic and limit deviations of resultants dimensions b follow from the above basic equation and general rules described in Section 2.3.

$$\delta b_c = \delta k_c - \delta a_c - \delta h_{hc} - \delta h_{wc},$$

$$\delta^2 b = \delta^2 k + \delta^2 a + \delta^2 h_h + \delta^2 h_w.$$

3 Vertical assemblies

Effects of random components of vertical deflection of horizontal hat profiles will be taken into account by appropriate accuracy characteristics of the storey height k in accordance with the general principles described in Section 2.1.

3.2.3 Analysis

To determine input accuracy characteristics of the storey height k , results of previous analysis in Section 3.1 and effects of hat profiles deformations due to loading are to be considered simultaneously. For the first approximation a hat profile as simply supported beam of the span $l = 3600 \text{ mm}$, exposed to uniform loading $q = 10 \text{ kN/m}$, is considered. If the section modulus of the hat profile is $I = 855.10^4 \text{ mm}^4$ and the modulus of elasticity is $E = 210 \text{ GPa}$, then the deflection z at the midspan point is given as

$$z = \frac{5}{384} \times \frac{q \times l^4}{E \times I} = 12.2 \text{ mm}$$

More detailed analysis show dependence of the deflection of a more realistic continuous beam on its spans and relative stiffness as indicated in Fig. 3.5.

Assumed loading $q = 10 \text{ kN/m}$ correspond to uniformly distributed load 2.38 kN/m^2 , which could well represent an average service load. Assembly load will be certainly lower: if it would be about one half of the above loading q , then the deflection would be about 6 mm . Due to natural variations of load and support conditions of any two profiles, difference of deflection of the upper and lower profile δz at any floor, may well be few millimetres (about $\pm 3 \text{ mm}$). This is the case, mentioned in Section 2.1, when deformations due to loading must be taken into account when analyzing geometric accuracy. The resulting limit deviation of the dimension k can be then determined in accordance with Section 2.1 as

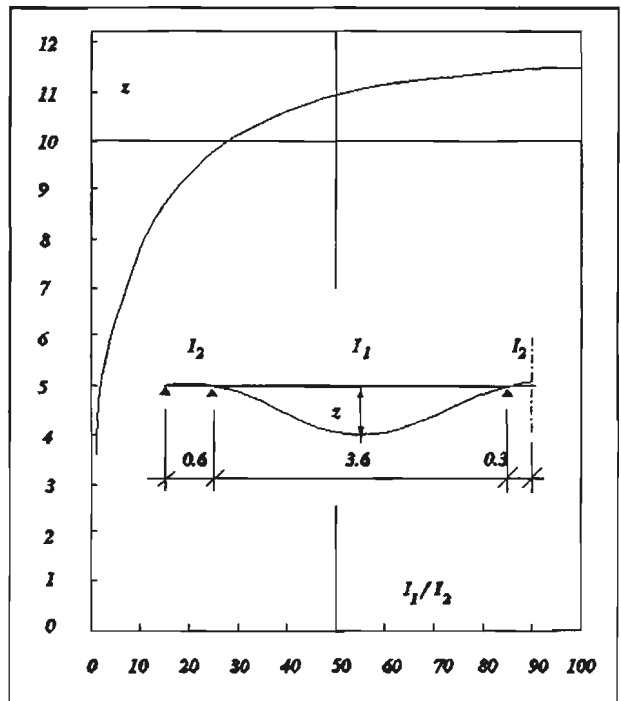

Fig. 3.5 Deflection of a hat profile.

$$\delta^2 k = \delta^2 k_1 + \delta^2 z .$$

3 Vertical assemblies

The input data for δk_i taken from Table 3.2 and estimated data for δz are given in the following Table 3.3 together with accuracy characteristics of the dimension k .

Table 3.3 Accuracy characteristics of the constituent dimension k .

Dimension	Stage (assembly or service)	Accuracy	
		lower	higher
k_i	both	2.0 ± 2.4	1.0 ± 1.2
z	assembly	0.0 ± 2.0	0.0 ± 1.0
	service	0.0 ± 3.0	0.0 ± 2.0
k	assembly	2.0 ± 3.1	1.0 ± 1.6
	service	2.0 ± 3.8	1.0 ± 2.3

It should be however noted that reduction of hat profile spans from 3600 mm to 3000 mm would decrease the deflections by the factor $(3000/3600)^4 = 0.48$, i.e. approximately to one half of the deflection z . This restricting measure would generally reduce unfavourable effects of deformations and would consequently lead to a slight decrease of the limit deviations of the dimension k given in the above table 3.3.

Effect of hat profile deflection on systematic gap between supporting hat profile and infill components of the width of 1200 mm is less than 0.2 mm as the factor by which the above deflection z is to be multiplied is $(1200/3600)^4 = 0.012$. However in view of and other unfavourable influences when erecting or relocating infill components, the accuracy characteristics of the dimension a in this section are considered separately for assembling stage and service stage and are estimated by moderately greater values than characteristics of similar dimensions a and a' in previous Section 3.1.

Accuracy characteristics of all constituent dimensions are now given in Table 3.4. Similarly as in the previous Section 3.1, two sets of input data corresponding to lower and higher accuracy of production are considered. Systematic and limit deviations of the storey height k , which is resulting dimension of the assembly investigated in Section 3.1, are taken from Table 3.3.

3 Vertical assemblies

Table 3.4 Accuracy characteristics of all constituent dimensions.

Dimensions	Stage (assembly or service)	Accuracy	
		lower	higher
k	assembly	2.0 ± 3.1	1.0 ± 1.6
	service	2.0 ± 3.8	1.0 ± 2.3
a	assembly	2.0 ± 2.0	1.0 ± 1.0
	service	3.0 ± 2.5	2.0 ± 1.5
h_v	both	0.0 ± 2.0	0.0 ± 1.0
h_b	both	0.0 ± 1.0	0.0 ± 0.5

Accuracy characteristics of resultant dimension b , determined using formula derived in the previous Section 3.2.2 and input data given in Table 3.4, are shown in the following Table 3.5.

Table 3.5 Accuracy characteristics of the resultant dimension b .

Dimension	Stage	Accuracy	
		lower	higher
b	erection	0.0 ± 4.3	0.0 ± 2.2
	service	-1.0 ± 5.1	-1.0 ± 3.0

The resulting systematic deviations are, however, favourably affected by positive systematic deviations of the storey height k_i and it should be clearly stated that if the size of the vertical components will be reduced, as recommended in Section 3.1.4, then the negative systematic deviations of the dimension b will increase in absolute value by that reduction. This factor is very important to take into account when investigating assembly of infill components as well as other related assemblies.

To guarantee smooth erection of infill components, negative values of the joint thickness b should be avoided. One obvious

3 Vertical assemblies

solution is to shorten the size of the infill components by the absolute value of the lower limit deviation of the dimension b , which could be as high as 6.1 mm , or in case of height reduction of bearing wall components more than that.

3.2.4 Conclusions and recommendations

The following conclusions may be drawn from the above analysis of the assembly of infill components in the bearing structure.

- A - The resulting accuracy characteristics of the joint between the top hat profiles and infill wall components clearly indicate that there is a considerable risk of construction difficulties when erecting or relocating infill components.
- B - To avoid these construction difficulties it is recommended to shorten the height of the infill components in accordance with actual accuracy of production by at least $3\text{ to }6\text{ mm}$.
- C - If the height of the bearing wall components will be reduced, then necessary shortening of the infill components should be respectively greater.
- D - It is recommended to reduce whenever possible the span of the hat profiles from 3600 mm to 3000 mm .
- E - Revised accuracy analysis of the assembly should be done whenever improved accuracy data, refined mechanical model and new practical experience are available.

3.3 Vertical coupling strips

3.3.1 Representative assembly

A joint of two wall components in vertical direction is shown in Fig. 3.6.

The assembly consists of two wall components, one above the other, with interlaying hat profile of the thickness t , which is separated from the upper and lower components by unintended gaps of thicknesses a and a' . The lower component has the first hole in the dimple of its face part located in a distance b' from its upper edge, the upper component has the first hole located in a distance b from its lower edge. To fit the holes of a vertical coupling strip, which are assumed to be located within designed distances accurately without any remarkable deviations, with the holes of dimples, the resulting distance

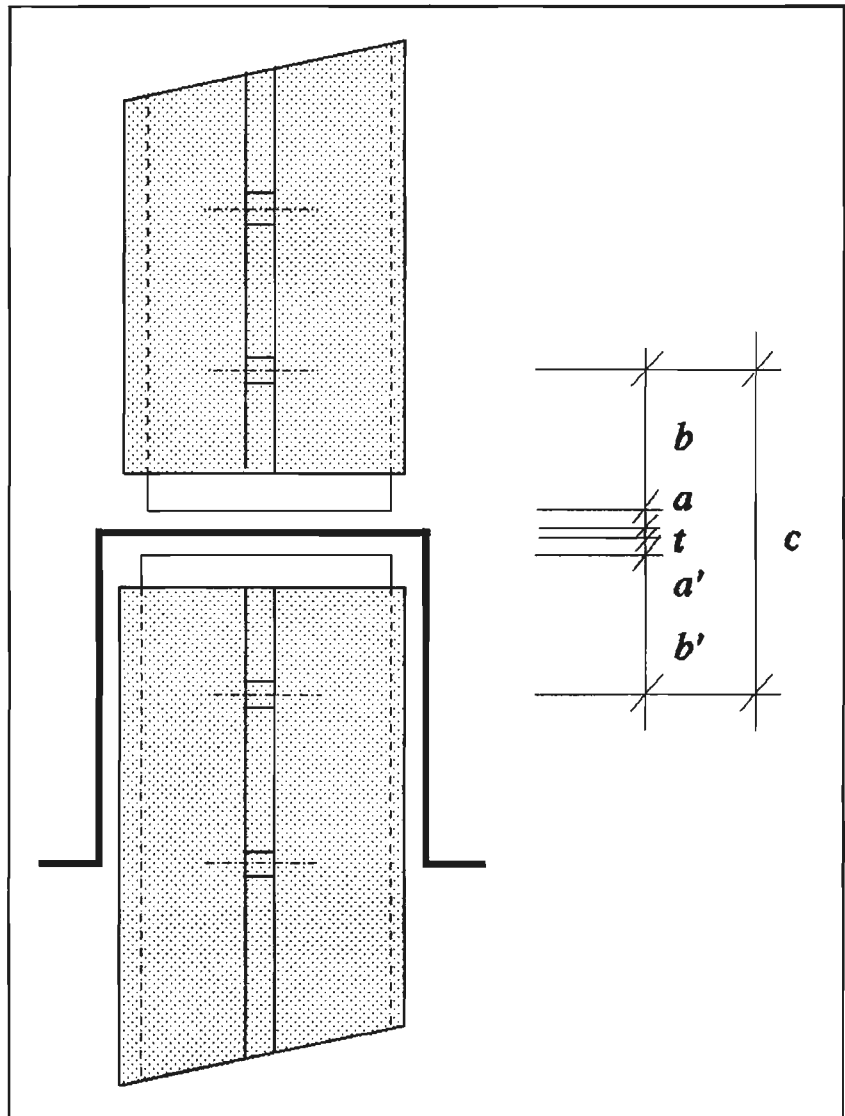

Fig. 3.6 Coupling connection of wall components.

c of the first holes in the dimples of two adjacent wall components, is to be within appropriate limits.

To determine accuracy characteristics of the distances b and b' of the first holes from the upper and lower edges of wall

3 Vertical assemblies

components, assembly of a wall part and side part of a wall component, as indicated in Fig. 3.7, is considered independently.

It is assumed that the holes in the dimples of a side part are located accurately from its both ends and consequently both dimensions h_s and h'_s , indicated in Fig. 3.7 have the same deviations. Inaccuracy of the heights h_s and h_w may, however cause some deviations of the dimensions b and b' . There are two possible alternatives how to assemble wall and side parts together.

(a) By the assembly only one end of both parts is controlled and edges of these members at this end are adjusted to uppermost coincidence; consequently one dimension, say b is very accurate, while the other dimension b' will have some deviation.

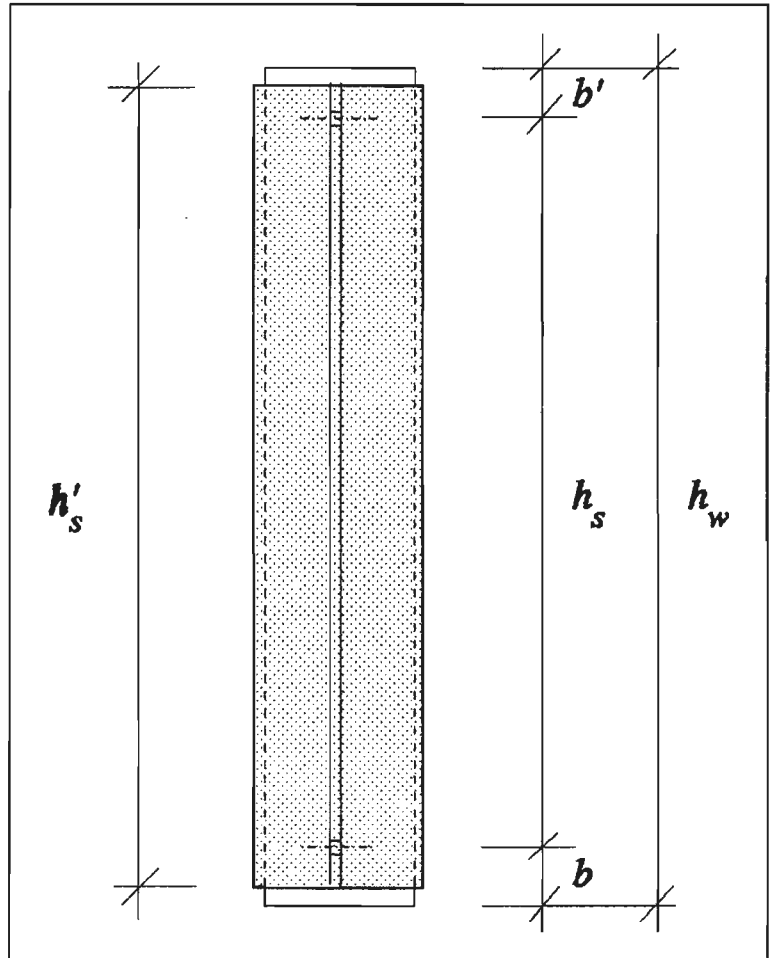

Fig. 3.7 A wall component.

(b) By the assembly both ends are simultaneously controlled and the side part is attached to the wall part symmetrically such that both distances b and b' are approximately equalized; consequently both these dimensions have the same deviations.

Both alternatives are considered in the following analysis simultaneously and it is shown that they yield different accuracy of the dimensions b and b' . Relevant accuracy characteristics should be, however, always related to the actual assembling procedure and, if necessary, the entire analysis should be modified. It should be also noted, that the assembly analyzed in this section is closely related to the previous basic vertical assembly described in Section 3.1. When some modification of that assembly, as they are recommended, are accepted, then the results of the following analysis are to be accordingly modified.

3.3.2 Theoretical model

Classification of dimensions

Constituent dimensions:

Variant (a): h_v, h_s, b, a, a', t , all independent.

Variant (b): h_v, h_s, a, a', t , all independent.

Resultant dimensions:

Variant (a): b', d .

Variant (b): b, b' for one component mutually dependent controlled dimensions, c .

Basic equations

Variant (a):

$$b' = h_v - b - h_s,$$

Variant (b):

$$b + b' = h_v - h_s.$$

Variants (a) and (b):

$$c = a + a' + b + b' + t.$$

Equations for accuracy characteristics of resultant dimensions

Equations for accuracy characteristics follows from the above basic equations and general principles described in Section 2.3.

Variant (a):

$$\delta b'_c = \delta h_v - \delta b_c - \delta h_{sc},$$

$$\delta^2 b' = \delta^2 h_v + \delta^2 b + \delta^2 h_s,$$

Variant (b): Mutual dependence of the dimensions b and b' referring to one component is expressed by their coefficient of correlation r .

$$\delta b_c + \delta b'_c = \delta h_v - \delta h_{sc}.$$

$$\delta^2 b + \delta^2 b' + 2r\delta b\delta b' = \delta^2 h_v - \delta^2 h_s.$$

Variants (a) and (b): Here dimensions b and b' refers to two different components and therefore are mutually independent dimensions.

3 Vertical assemblies

$$\delta c_c = \delta a_c + \delta a'_c + \delta b_c + \delta b'_c + \delta t_c.$$

$$\delta 2c = \delta^2 a + \delta^2 a' + \delta^2 b + \delta^2 b' + \delta^2 t.$$

3.3.3 Analysis

Accuracy characteristics of constituent dimensions are given in Table 3.6. Again two sets of input data are estimated for lower and higher accuracy of production. Systematic and limit deviations of the dimensions h_1 and h_2 are assumed to be the same as for the heights of the bearing components h_i and also accuracy characteristics of the dimensions a and a' are the same as in the analysis of previous vertical assembly described in Section 3.1. Limit deviation of the dimension b describing coincidence of both parts of wall components is merely assessed and should be again verified by control measurements or practical experience.

Table 3.6 Accuracy characteristics of constituent dimensions.

Dimensions	Variants (a) or (b)	Accuracy	
		lower	higher
h_1, h_2	(a) and (b)	0.0 ± 2.0	0.0 ± 1.0
a, a'	(a) and (b)	1.0 ± 1.0	0.5 ± 0.5
b	(a) only	0.0 ± 1.0	0.0 ± 0.5
t	(a) and (b)	0.0 ± 0.0	0.0 ± 0.0

Accuracy characteristics of resultant dimensions, derived for both levels of production accuracy from the above input data using general relationships described in the previous Sections 3.3.2, are given in Table 3.7. Obtained accuracy characteristics indicate some important risks of misfit, which should be analyzed in detail.

First the limit deviations of the dimensions b and b' (which show coincidence of edges of wall and its side parts) clearly demonstrate that the side parts of components may exceed the wall parts. This misfit could be as high as 3 mm in the variant (a) and 2 mm in the variant (b). If this circumstance is unacceptable (from bearing capacity considerations), then it would be necessary to design the height of the side parts shorter, by the absolute value of the limit deviation δb given in Table 3.7, then the size of wall parts. Before accepting that measure, actual assembling procedure should be investigated and control measurements should be checked against assumed accuracy characteristics of constituent as well as derived characteristics of the resultant dimensions.

Table 3.7 Accuracy characteristics of the resultant dimension c .

Dimension	Variant (a) or (b)	Accuracy	
		lower	higher
b'	(a)	0.0 ± 3.0	0.0 ± 1.5
b, b'	(b) for $r = 0.0$	0.0 ± 2.0	0.0 ± 1.0
	(b) for $r = 0.5$	0.0 ± 1.6	0.0 ± 0.8
	(b) for $r = 1.0$	0.0 ± 1.4	0.0 ± 0.7
c	(a)	2.0 ± 4.2	1.0 ± 2.2
c	(b) for $r = 0.0$	2.0 ± 3.2	1.0 ± 1.6
	(b) for $r = 0.5$	2.0 ± 2.7	1.0 ± 1.3
	(b) for $r = 1.0$	2.0 ± 2.4	1.0 ± 1.2

Further it also follows from the resulting systematic and limit deviations of the dimension c , given in the above Table 3.7, that the upper limit deviations could be quite high (6.2 mm for lower accuracy of production and variant (a), however always greater than 2.2 mm, valid for the variant (b), correlation coefficient $r = 1.0$ and the higher accuracy of production). These deviations may cause problems in fitting the holes in the strips and dimples.

Thus it is recommended to use preferably variant (b) for assembling walls, to shorten the distances b and b' by the systematic deviation of the dimension c , i.e. by 2 or by 1 mm in accordance with the actual accuracy of production. Moreover it is advisable to make oval holes in the strips so that their longitudinal dimension (in vertical direction) will be at least by 6 or 3 mm (according to the actual accuracy of production) greater than the required diameter of the holes to insert the bolts.

As mentioned above, it should be underlined particularly here, that the input data may not reflect the actual accuracy of production and it is highly recommended to revise the analysis in view of, relevant measurements and newly becoming practical experience. Construction details of vertical coupling strips may be also very sensitive to deviations of horizontal coincidence of two dimples of vertically adjacent wall components, which should be analyzed separately.

3.3.4 Conclusions and recommendations

The following conclusions and recommendations can be drawn from the obtained results.

- A - Due to various dimensional deviations there is considerable risk of misfit of the holes in the vertical dimples and coupling strips.
- B - The variant (b) of attaching the side parts to the wall parts of wall components leads to slightly better resulting accuracy than the variant (a).
- C - In order to avoid undesired longer side parts than the wall parts of the components, the side parts are to be designed shorter by 2 or 3 mm than the walls parts.
- D - It is recommended to use the variant (b) and then to shorten the distances of the first holes from the edges of the wall components by 1 or 2 mm, and furthermore to make oval holes in the strips so that their longitudinal dimension will be greater than the required diameter of the holes; in case of higher accuracy of production this elongation should be at least 3.0 mm.
- E - It is highly recommended to verify input data describing dimensional deviations of wall heights and unintended gaps between hat profiles and wall components in the vertical direction.

4 HORIZONTAL ASSEMBLIES

4.1 Horizontal coupling strips

4.1.1 Representative assembly

Typical joint of two floor components in horizontal direction is shown in Fig.4.1. The assembly consists of two neighbouring floor components, one besides the other, with interlaying hat profile of the width t , which is separated from the left and right floor components by two joints o' and o .

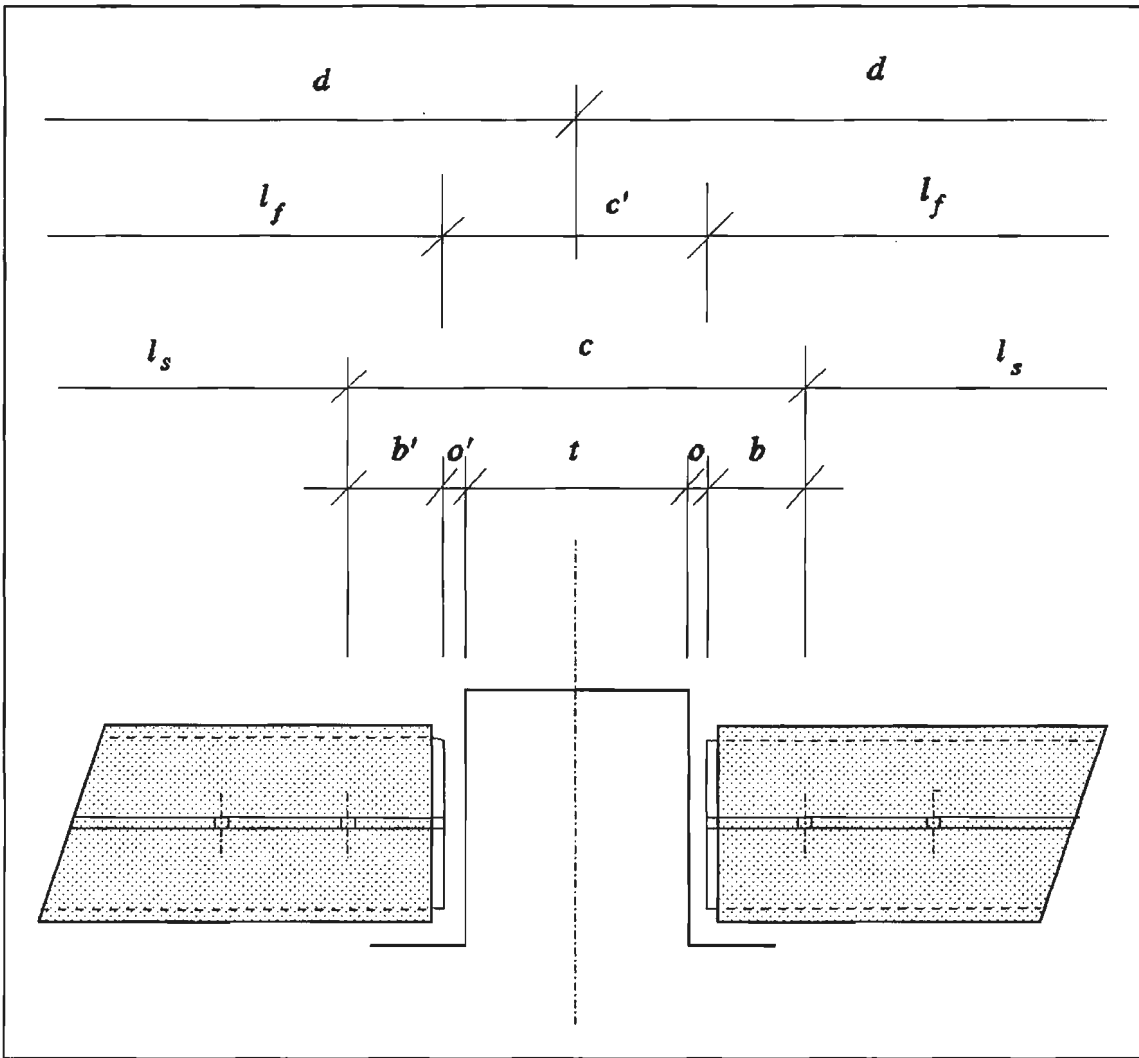

Fig. 4.1 Joint of floor components.

4.1 Horizontal assemblies

The left component has the first hole in the dimple of its side part located in a distance b' from its right edge, the right component has the first hole located in a distance b from its left edge.

In order to fit the holes of a horizontal coupling strip, which are assumed to be located within designed distances accurately without any noticeable deviations, with the holes in dimples, location of adjacent floor components will be adjusted by a force. As a result of this rectification the resulting distance c of the first holes in dimples of the adjacent floor components should conform the distance of the holes in the strip. Thus no oval holes in horizontal coupling strips are foreseen as in the previous case of vertical coupling strips.

It is assumed, that walls with their hat profiles can be also relocated in accordance with the adjustments of floor components. However there is a considerable chance (due to unexpected obstacles including friction), that one joint, say o' , is zero (hat profile is then in contact with a face of one floor component) and the other joint, denoted in that case o^* , between hat profile and floor component become greater than in case when both joints are approximately equalized. The joint width o^* should be checked in order to verify supporting length of the corresponding floor component.

To determine accuracy characteristics of the dimensions b and b' of the first holes in the dimples of floor components, assembly of its floor and side parts, as indicated in Fig.4.2, is to be considered independently.

It is assumed that the holes in the dimples are located accurately from the ends of side parts. However, deviations of the lengths of floor parts l_f and length of side parts l_s (which differs from the length l'_s , only by a deterministic value) of floor components, may cause some deviations of the dimensions b and b' , similarly as in the previous

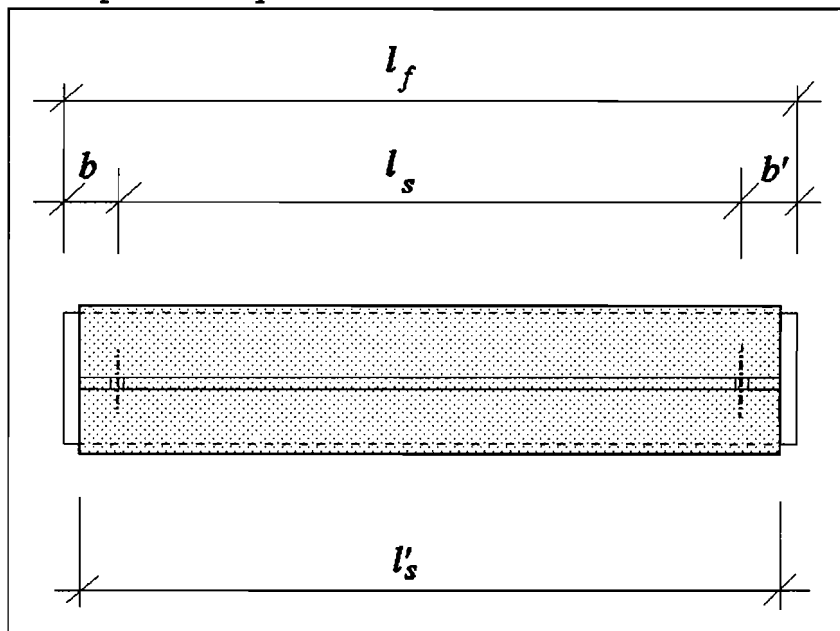

Fig. 4.2 A floor component.

case of wall components, analyzed in Section 3.3. Again there are two possible alternatives how to assemble floor and side parts

4.1 Horizontal assemblies

together:

- (a) By the assembly only one end of both parts is controlled and edges of both parts at this end are adjusted to the uppermost coincidence; consequently one dimension, say b is very accurate, while the other dimension b' may have somewhat greater deviations.
- (b) By the assembly both ends are simultaneously controlled and the side part is attached to the floor part symmetrically such that both distances b and b' are approximately equalized; consequently both these dimensions should have the same accuracy characteristics.

Both alternatives (a) and (b), which lead to different accuracy characteristics, are considered in the following analysis simultaneously as in case of vertical coupling strips analyzed in Section 3.3. In order to make the following sections self content, the entire analysis is described in detail.

4.1.2 Theoretical model

Classification of dimensions:

Constituent dimensions:

Variant (a): l_f, l_s, b, c, t , all independent.

Variant (b): l_f, l_s, c, t , all independent.

Resultant dimensions:

Variant (a): b', o^*, o, o' , last two represent controlled dimensions.

Variant (b): b, b' , for one component mutually dependent controlled dimensions, o^*, o, o' , last two represent controlled dimensions.

Basic equations:

Variant (a):

$$b' = l_f - b - l_s,$$

Variant (b):

$$b + b' = l_f - l_s.$$

Variants (a) and (b):

$$o + o' = c - b - b' - t,$$

4.1 Horizontal assemblies

$$o^* = c - b - b' - t.$$

Equations for accuracy characteristics of the resultant dimensions:

Equations for accuracy characteristics follows from the above basic equations and general principles for the fundamental linear equations and basic equation for couple of controlled resultant dimensions described in Section 2.3.

Variant (a):

$$\delta b'_c = \delta l_f - \delta b_c - \delta l_{sc},$$

$$\delta^2 b' = \delta^2 l_f + \delta^2 b + \delta^2 l_{sc},$$

Variant (b): Mutual dependence of the dimensions b and b' referring to one component is expressed by their coefficient of correlation r_b .

$$\delta b_c + \delta b'_c = \delta l_{fc} - \delta l_{sc},$$

$$\delta^2 b + \delta^2 b' + 2r_b \delta b \delta b' = \delta^2 l_f + \delta^2 l_{sc}.$$

Variants (a) and (b): Here the dimensions b and b' refers to two different components and therefore are mutually independent dimensions. If one joint width is zero, the accuracy characteristics of the other joint o^* are given as

$$\delta o^*_c = \delta c_c - \delta b_c - \delta b'_c - \delta t_c.$$

$$\delta^2 o^* = \delta^2 c + \delta^2 b + \delta^2 b' + \delta^2 t.$$

If both joints o and o' are non-zero, their mutual dependence may be described by the correlation coefficient r_o , for which relatively low value (close to 0) should be expected.

$$\delta o_c + \delta o'_c = \delta c_c - \delta b_c - \delta b'_c - \delta t_c,$$

$$\delta^2 o + \delta^2 o' + 2r_o \delta o \delta o' = \delta^2 c + \delta^2 b + \delta^2 b' + \delta^2 t.$$

Obviously systematic deviations of the joint widths o^* would be double and limit deviations would be higher by the factor $\sqrt{2} = 1.41$ than corresponding characteristics of joints o and o' . Likelihood of this unfavourable case should be verified by practical experience and, if necessary, avoided by specifying appropriate rectification procedure.

4.1.3 Analysis

Accuracy characteristics of constituent dimensions are given in Table 4.1. Again two sets of input data are estimated for lower and higher accuracy of production. Systematic and limit

4.1 Horizontal assemblies

deviations of the dimensions l_1 and l_2 are assumed to be the same as for the heights of wall components h_1 and h_2 in previous section 3.3. Limit deviations of the dimension b , describing coincidence of both parts of floor components in the variant (a), are only assessed and should be also, as number of other estimates, verified by practical measurements.

Accuracy characteristics of the distance c , is assessed from the following important consideration, which is illustrated by Fig. 4.3. Holes in dimples and in the strips are designed larger by 1 mm than the bolts diameters. Therefore the extreme differences from the precise value, indicated in Fig.4.3, would never exceed the values ± 2 mm. However, if the bolt is fastened first on one side centrally, which is supposed to be possible by suitable mounting technique, then the extremes would drop to ± 1 mm (this corresponds to one side extremes in Fig. 4.3).

The corresponding standard deviation of the distance c is assessed assuming, that the extremes correspond to $\pm 3\sigma$ (which is usually considered as "practical extremes"). In the first, less accurate case, when the central fastening of the first bolt is not efficient (and more "safe" assumption ± 2 mm is considered for the extremes), the limit deviation δc is thus given as

$$\delta c = (2/3) * 1.64 = 1.0 \text{ mm,}$$

in the second, more accurate case (when assumption ± 1 mm is considered for the extremes) as

$$\delta c = (1/3) * 1.64 = 0.5 \text{ mm.}$$

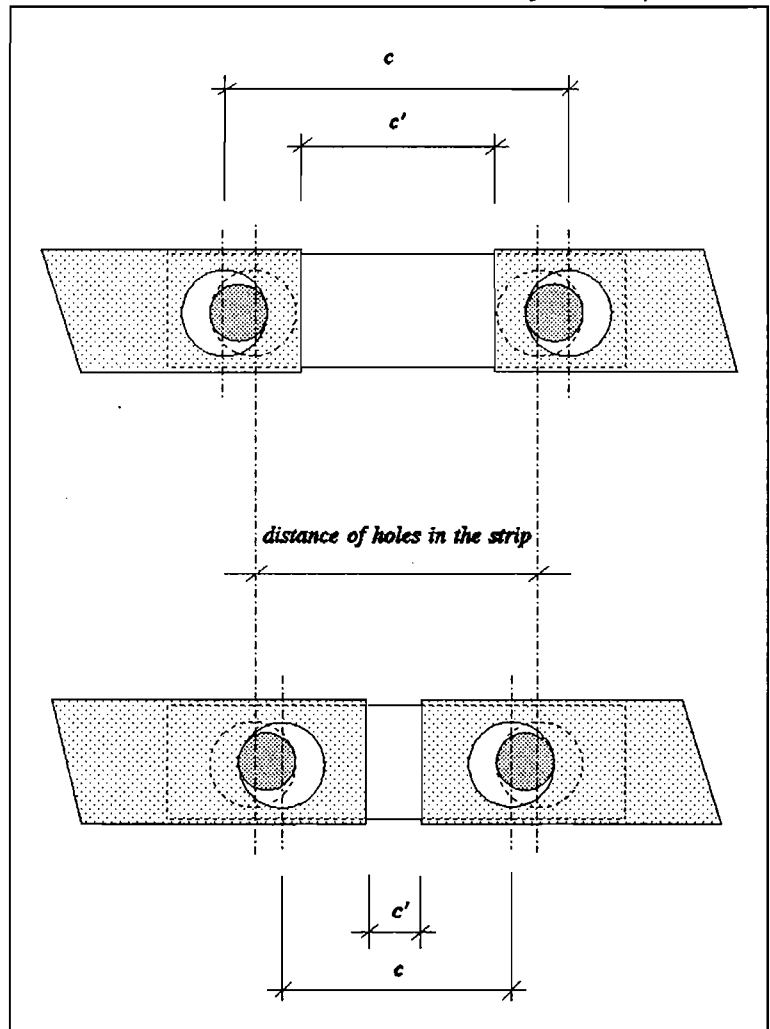

Fig. 4.3 The extreme location of holes.

The above two estimates are used to represent lower and higher accuracy of erection. Both estimates are obviously partly hypothetical and

4.1 Horizontal assemblies

should be verified by appropriate experimental investigations. It would be desirable to prove, that appropriate application of a force (when assembling a strip with two neighbouring floor components) may lead to even higher actual accuracy than that, indicated by the above estimates of limit deviation δc for lower and higher accuracy.

Table 4.1 Accuracy characteristics of constituent dimensions.

Dimensions	Variants (a) or (b)	Accuracy	
		lower	higher
l_f, l_s	(a) and (b)	0.0 ± 2.0	0.0 ± 1.0
b	(a) only	0.0 ± 1.0	0.0 ± 0.5
c	(a) and (b)	0.0 ± 1.0	0.0 ± 0.5
t	(a) and (b)	$x \pm 1.5$	$y \pm 1.0$

The systematic deviation of all constituent dimension except the hat profile are zero. It is expected that there might be some systematic deviations of the hat width t due to presumed production procedure, which should be determined using desired experimental data. For the time being the unknown quantities x and y , which are introduced to indicate this uncertainty, may be considered to be approximately zero.

The results of the following analysis depend also on two correlation coefficients. For the correlation coefficient r_b , three values are generally considered as in the previous chapter 3. Correlation coefficient r_o of joints o and o' is assumed to be zero and it is to be remind, that when one of these joints is zero, then the resulting accuracy characteristics of the other joint o^* are considerably different from characteristics of joints o and o' .

Accuracy characteristics of resultant dimensions derived from the above input data using general relationships described in the previous Sections 4.1.2, are given in Table 4.2.

The resulting accuracy characteristics given in Table 4.2 indicate some important risks of misfit. First, similarly as in the previous case of wall components analyzed in section 3.3, the limit deviations of the dimensions b and b' (which also indicate coincidence of edges of floor and side parts) clearly demonstrate that the side parts may overstep the walls parts. This misfit could be as high as 3 mm in the variant (a) and 2 mm in the variant (b). When this phenomena is unacceptable, then it would be necessary to design the length of the side parts shorter than size of floor parts by the above indicated magnitudes.

4.1 Horizontal assemblies

Table 4.2 Accuracy characteristics of resultant dimensions.

Dimensions	Variants (a) or (b)	Accuracy	
		lower	higher
b'	(a) only	0.0 ± 3.0	0.0 ± 1.6
o^*	(a) only	$-x \pm 3.6$	$-y \pm 1.9$
o, o'	(a) only	$-x/2 \pm 2.6$	$-y/2 \pm 1.4$
b, b'	(b) for $r_b=0.0$	0.0 ± 2.0	0.0 ± 1.0
	(b) for $r_b=0.5$	0.0 ± 1.6	0.0 ± 0.8
	(b) for $r_b=1.0$	0.0 ± 1.4	0.0 ± 0.7
o^*	(b) for $r_b=0.0$	$-x \pm 3.4$	$-y \pm 1.8$
	(b) for $r_b=0.5$	$-x \pm 2.9$	$-y \pm 1.6$
	(b) for $r_b=1.0$	$-x \pm 2.7$	$-y \pm 1.5$
o, o'	(b) for $r_b=0.0$	$-x/2 \pm 2.4$	$-y/2 \pm 1.3$
	(b) for $r_b=0.5$	$-x/2 \pm 2.1$	$-y/2 \pm 1.1$
	(b) for $r_b=1.0$	$-x/2 \pm 1.9$	$-y/2 \pm 1.1$

Second, the limit deviations of the joint o^* indicate, that when one of the joint width o and o' is zero, the other could be within broad limits up to ± 3.6 mm in case of the variant (a), or ± 3.4 mm in case of the variant (b). Assuming further on more accurate variant (b) only, it follows from the table 4.2, that the design value for sum of the joint widths $o + o'$ should be at least 3 mm for lower accuracy and 2 mm for the higher accuracy of erection. It is however strongly recommended, until appropriate data will be available, to accept the result for lower accuracy and to design floor components at least by 3 mm shorter (therefore to design joint widths 1.5 mm) and simultaneously to prescribe extrusion of the supporting segments from the side walls of hat profiles 6 mm.

Further, it follows from the resulting characteristics for dimensions o and o' , given in table 4.2, that if there are not contacts between the hat profiles and floor components, the limit deviations of each joint could be greater than above recommended design value. For the assumed correlation coefficient $r_b = 0$, the limit deviations are within the interval from 1.1 mm (see the variant (b), correlation coefficient $r_b = 1.0$ and the higher accuracy) and 2.6 mm (valid for lower accuracy and the variant (a)). Consequently, if the contact between the hat profiles and floor components should be avoided, the width of each joint should be increased to at least 2.0 mm and a safe extrusion of

4.1 Horizontal assemblies

supporting segments would be then $4.0 + 3.4 = 7.4 \approx 8 \text{ mm}$.

Expected experimental investigation of the considered assembly of floor components should verify validity of input data used for constituent dimensions and feasibility of application of a force to adjust location of floor components. Furthermore it should also verify an important aspect of structural safety, that application of a force does not deform supporting segments extruded from hat profiles and therefore does not endanger necessary supporting length of floor components.

4.1.4 Conclusions and recommendations

The following conclusions and recommendations can be drawn from the above analysis.

- A - The variant (b) of assembling side parts and floor parts of the floor components leads to slightly better resulting accuracy than the variant (a).
- B - In order to avoid undesired longer side parts than the floor parts, the side parts should be designed shorter by 2 or 3 mm than the floor parts.
- C - It is recommended to use the variant (b) and to design joint widths at least 1.5 mm, thus to design floor components at least by 3 mm shorter than intended opening between hat profiles. Extrusion of supporting segments from sides of hat profiles should be 6 mm.
- D - It is highly recommended to verify input data describing dimensional deviations of floor components and hat profiles in horizontal direction and to verify feasibility of adjustment using a force when inserting horizontal coupling strips into dimples of floor components.

4.2 Horizontal assemblies

4.2 Floor components

4.2.1 Representative assembly

Basic representative assembly of vertical and horizontal components characterizing dimensional accuracy of the structure in longitudinal horizontal direction, which is investigated independently of remaining structural parts, is shown in Fig.4.4 and Fig.4.5, differing by indicated sets of constituent dimensions.

Longitudinal section of the structure shows row of three floor components erected on four wall components, as an example of a more general assembly of n horizontal components erected on $n + 1$ vertical components. At the end of whole assembly, the first and the last wall components, denoted by subscripts 1 and $n + 1$, are always fixed in vertical direction by shear walls. The number n of floor components between shear walls, is not fixed (could be as high as 12) and will be discussed in view of results of the following analysis.

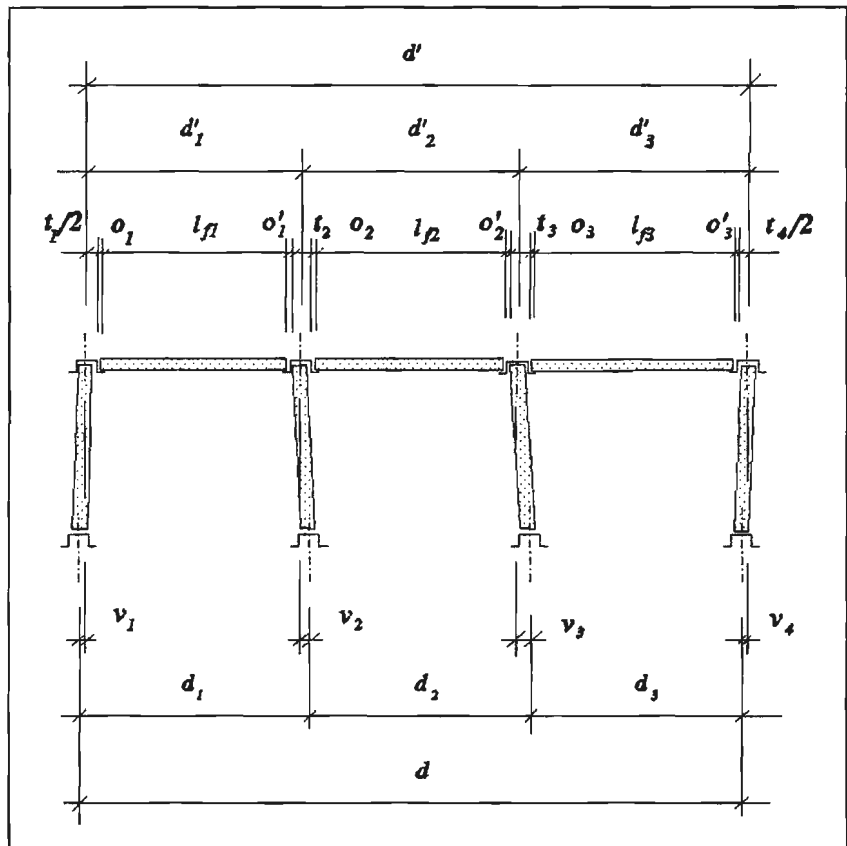

Fig. 4.4 Assembly of floor components.

To assemble considered part of the structure, first the vertical components are erected within measured distances d_i , $i = 1, 2, \dots, n$, which are derived from the total length d . The deviations from verticality of the first (left) wall component, denoted v_1 is always checked and fixed by shear walls before

4.2 Horizontal assemblies

erecting floor components. There are, however, two possible alternatives when to fixed the verticality of the last wall component:

- (a) verticality of the last wall is fixed after the erection of floor components;
- (b) verticality of the last wall is fixed before the erection of floor components.

According to the first variant (a) verticality of the last wall is adjusted to fit the actual position of the last floor component denoted by subscript n . The verticality v_{n+1} is therefore the resulting dimension of the assembly. In accordance with the variant (b) the verticality of the last components v_{n+1}^* is predetermined by the shear walls and may obviously defer from the verticality v_{n+1} following from the assembly of floor components. Then the difference $v = v_{n+1} - v_{n+1}^*$ must be somehow accommodated by the last joint of floor and wall components.

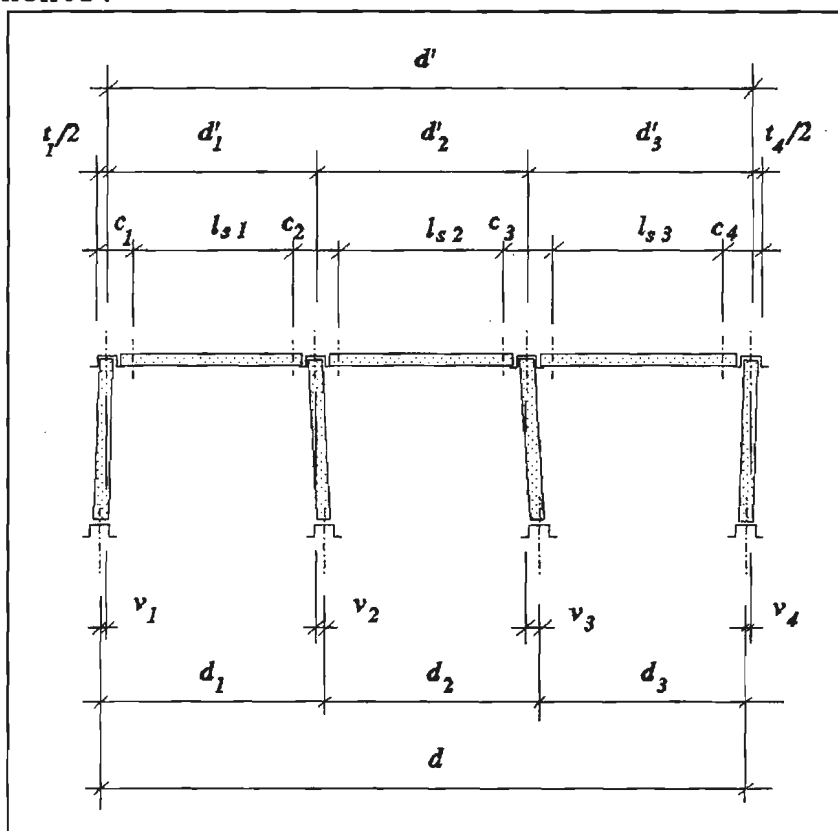

Fig. 4.5 Assembly of floor components.

Verticalities v_i of the other wall components, designated by subscripts $i = 2, \dots, n$ (see Fig.4.4) are always affected by actual deviations of horizontal joints o_i, o'_i . Accuracy of these dimensions is analyzed in previous Section 4.1, where also detailed erection procedure of horizontal joints is described. The following analysis is in fact based on assumptions and results obtained in this section.

All indicated components are approximately considered as one dimensional members, while deviations of their actual shape from the parallelogram (skewness, straightness, non-parallelness) and induced deviations due to skew positioning of components are

4.2 Horizontal assemblies

assumed to be included in accuracy characteristics of those dimensions indicated in Fig.4.3. It is assumed that this simplified approach would sufficiently well describe actual accuracy of the structure in horizontal direction.

Functional requirements are to be generally verified for verticalities v_i of the walls due to safety and stability aspects, for joints o_i , o'_i due to construction requirements (to fit the floor components in between the hat profiles) and for supporting lengths of the floor components, which are placed on small segments located on side walls of the hat profiles. Accuracy characteristics of joints o_i , o'_i follows from the analysis in previous Section 4.1, where also consequences on supporting components are considered. Effects of assumed erection procedure on resulting wall distances d'_i , $i = 1, 2, \dots, n$, d' and on verticalities v_i , $i = 1, 2, \dots, n+1$ and the difference $v = v_{n+1} - v_{n+1}^*$ is investigated below.

4.2.2 Theoretical model

Proposed theoretical model follows from erection procedure described above (see also Fig.4.4 and Fig.4.5) and in the previous Section 4.1 (see Fig.4.1), where accuracy of joint widths o_i , o'_i is presented.

Classification of dimensions

Constituent dimensions:

Variant (a): d , v_i , t_i , l_{si} , c_i , ($i = 1, 2, \dots, n$), t_{n+1} ; all mutually independent dimensions, d'_i , ($i = 1, 2, \dots, n$), derived from d .

Variant (b): d , v_i , t_i , l_{si} , c_i , ($i = 1, 2, \dots, n$), t_{n+1} , v_{n+1}^* ; all mutually independent dimensions.

Resultant dimensions:

Variant (a): d'_i , v_{i+1} , ($i = 1, 2, \dots, n$), d' .

Variant (b): d'_i , v_{i+1} , ($i = 1, 2, \dots, n$), d' , v .

Basic equations

Variant (a) and (b):

4.2 Horizontal assemblies

$$d'_i = t_i/2 + o_i + l_{fi} + o'_i + t_{i+1}/2, \\ i=1,2,\dots,n;$$

$$d' = - t_1/2 + \sum_{i=1,2,\dots,n} l_{si} + \sum c_i + c_{n+1} - t_{n+1}/2,$$

$$v_{n+1} = v_1 + d - d',$$

Variant (b): the same as in variant (a) and additionally

$$v = v_{n+1} - v^*_{n+1}.$$

Equations for accuracy characteristics of resultant dimensions

Equations for systematic and limit deviations of the resultant dimensions follow from the above basic equations and general rules presented in Section 2.3. As follows from the basic equations the variant (b) has only one additional relation compare to the variant (a). Consequently for both variants are treated simultaneously.

Variant (a) and (b):

Systematic deviations:

$$\delta d'_{ic} = \delta t_{ic}/2 + \delta o_{ic} + \delta l_{fic} + \delta o'_{ic} + \delta t_{i+1,c}/2, \\ i=1,2,\dots,n;$$

$$\delta d'_c = - \delta t_{1c}/2 + \sum_{i=1,2,\dots,n} \delta l_{sic} + \sum \delta c_{ic} + \delta c_{n+1,c} + \delta t_{n+1,c}/2,$$

$$\delta v_{n+1,c} = \delta v_{1c} + \delta d'_c - \delta d_c,$$

Limit deviations:

$$\delta^2 d'_i = \delta^2 t_i/4 + \delta^2 o_i + \delta^2 l_{fi} + \delta^2 o'_i + \delta^2 t_{i+1}/4, \\ i=1,2,\dots,n;$$

$$\delta^2 d' = \delta^2 t_1/4 + \sum_{i=1,2,\dots,n} \delta^2 l_{si} + \sum \delta^2 c_i + \delta^2 c_{n+1} + \delta^2 t_{n+1}/4,$$

$$\delta^2 v_{n+1} = \delta^2 v_1 + \delta^2 d' + \delta^2 d,$$

Variant (b) only:

Systematic deviations:

$$\delta v_c = \delta v_{n+1,c} - \delta v^*_{n+1,c}.$$

Limit deviations:

$$\delta^2 v = \delta^2 v_{n+1} + \delta^2 v^*_{n+1}.$$

4.2 Horizontal assemblies

4.2.3 Analysis

As in previous analysis of vertical assemblies two sets of accuracy characteristics for lower and higher accuracy of production are considered in the following analysis for constituent as well as for resulting dimensions.

The following analysis assumes accuracy characteristics for joint widths o_i and o'_i derived in previous section for variant (b) and the coefficient of correlation $r = 0.5$ as given in table 4.2; unless more evident data are available the middle value $r = 0.5$ may well represent a good estimate.

Variant (a) and (b):

Two sets of accuracy characteristics of constituent dimensions, given in the table 4.3, are considered in the following numerical analysis. Except d all other constituent dimensions have the accuracy characteristics independent of the floor level. The resulting distance d' at the first floor, corresponding to d at the ground floor, could have obviously somehow greater limit deviation than the original dimension d .

Table 4.3 Accuracy characteristics of constituent dimensions.

Dimensions	Accuracy	
	lower	higher
d	0.0 ± 4.0	0.0 ± 2.0
v_i, v^*_{i+1}	0.0 ± 2.0	0.0 ± 1.0
t_i	$x \pm 1.5$	$y \pm 1.0$
o_i, o'_i	$-x/2 \pm 2.0$	$-y/2 \pm 1.0$
l_{ti}, l_{si}	0.0 ± 2.0	0.0 ± 1.0
c_i	0.0 ± 1.0	0.0 ± 0.5

Accuracy characteristics of resultant dimensions, determined using relevant relationships derived in section 4.1.2 and input data given in the previous table 4.3, are presented in the following table 4.4.

4.2 Horizontal assemblies

Table 4.4 Accuracy characteristics of resultant dimensions.

Dimension	Number of floor components n	Accuracy	
		lower	higher
d'_i	---	0.0 ± 3.6	0.0 ± 1.9
d'	4	0.0 ± 4.7	0.0 ± 2.4
	6	0.0 ± 5.7	0.0 ± 2.9
	8	0.0 ± 6.5	0.0 ± 3.3
	10	0.0 ± 7.2	0.0 ± 3.6
	12	0.0 ± 7.9	0.0 ± 4.0
v_{n+1}	4	0.0 ± 6.5	0.0 ± 3.3
	6	0.0 ± 7.2	0.0 ± 3.6
	8	0.0 ± 7.9	0.0 ± 4.0
	10	0.0 ± 8.5	0.0 ± 4.3
	12	0.0 ± 9.1	0.0 ± 4.6

The first important message indicated by the resulting accuracy characteristics concerns the dimension and d' . Clearly the limit deviation for this dimension (for $n=12$ in the range from 4.0 to 7.9 mm) considerably exceeds the input limit deviations considered for d (from 2 to 4 mm) at the ground level. It seems to be impossible to assemble the next storey without control measurement and adjustment of the distance d' at the level of the first floor. Nevertheless such a correction may have limited effect and it should be expected, that accuracy of the next storey could be considerably lower than the accuracy of the first storey.

Derived accuracy characteristics for the verticalities v_{n+1} indicate, that for the number of floor components $n = 12$ the verticality of the last vertical component should be expected in the range from 4.6 to 9.1 mm. However, as it follows from the above discussion, at the higher floors the limit deviations of verticalities may easily exceeds the value of 10.0 mm. From the point of view of bearing capacity verticality deviations are most likely insignificant, but the consequences for fitting all components together may be very important.

In view of the equation for limit deviations in the variant (b) the corresponding range for the verticality difference v is slightly higher, namely from 5.0 to 9.3 mm, than verticality deviations of the last wall. If the variant (b) is applied, the

4.2 Horizontal assemblies

verticality difference v must be somehow accommodated by suitable joint technique of one (rectification) connection of floor components, hat profile and horizontal coupling strip.

It follows from the table 4.4, that all the discussed results depend on the number of floor components n . This dependence is, however, not linear. Shortening the distance between the shear walls to one half from $n = 12$ to $n = 6$ will reduce the resulting limit deviation only to approximately 80 %, which is considerably less than expected.

For both variants it holds, that the above derived results are valid only for the theoretical model of "positional redundant" assembling of floor components from the floor and side parts, as described in previous section 4.1.2. If other technique is applied, then the theoretical model must be modified in accordance with actual erection procedure.

4.2.4 Conclusions and recommendations

The following conclusions and recommendations can be drawn from the obtained results.

- A - Due to various dimensional deviations of both considered variants of erection procedures the limit deviations of wall verticalities may exceeds the value of 10.0 mm depending on number of floor components and accuracy level.
- B - After assembly of each floor, the axial distances d' of walls fixed by shear walls should be checked and adjusted. To correct the position of structural components effectively, a suitable rectification joints should be designed between every couple of shear walls.
- C - It is highly recommended to verify input data describing accuracy of setting out and erection of wall components in vertical direction and floor components in longitudinal horizontal direction.
- D - A special attention should be payed to verification of adjustment accuracy of the structure in horizontal direction by a force when inserting horizontal coupling strips into the dimples of adjacent floor components.

5 DOWEL CONNECTIONS

5.1 Connection of two wall components

5.1.1 Representative assembly

Typical joint of two wall components in vertical direction, shown in Fig.3.5, is described in Section 3.3. For two sets of neighbouring floor components, distinguished by subscripts 1 and 2 only, the assembly is schematically indicated in Fig.5.1.

Wall components bellow and above the hat profile are located within distances $a_{1(2)}$ and $a'_{1(2)}$ from the horizontal side of the hat. The lower components have the first holes in the dimples of their side parts located within distances $b'_{1(2)}$ from their top edge, the upper components have the first holes located within distances $b_{1(2)}$ from their bottom edge. Previous detail analyses of wall components assembly, using vertical coupling strips, is given in Section 3.3.

The following analyses of dowel connection of wall components concerns only two neighbouring upper components above the hat Fig. 5.1, for which the side view is indicated in Fig. 5.2. The holes, which should be used for bolts to connect two wall components using dowel moving parts, are located within the distances l_{d1} and l_{d2} from the first hole. Obviously, analogous conditions would be obtained for the components bellow the hat profile.

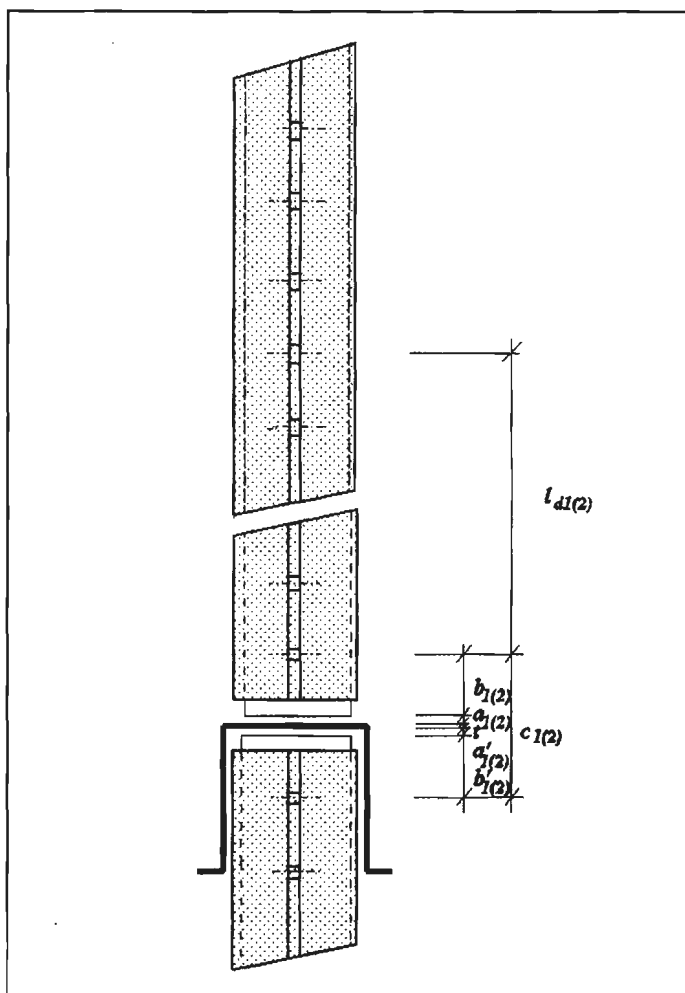

Fig. 5.1 Wall components.

5. Dowel connections

Accuracy characteristics of appropriate constituent dimensions are taken from previous Section 3.3.

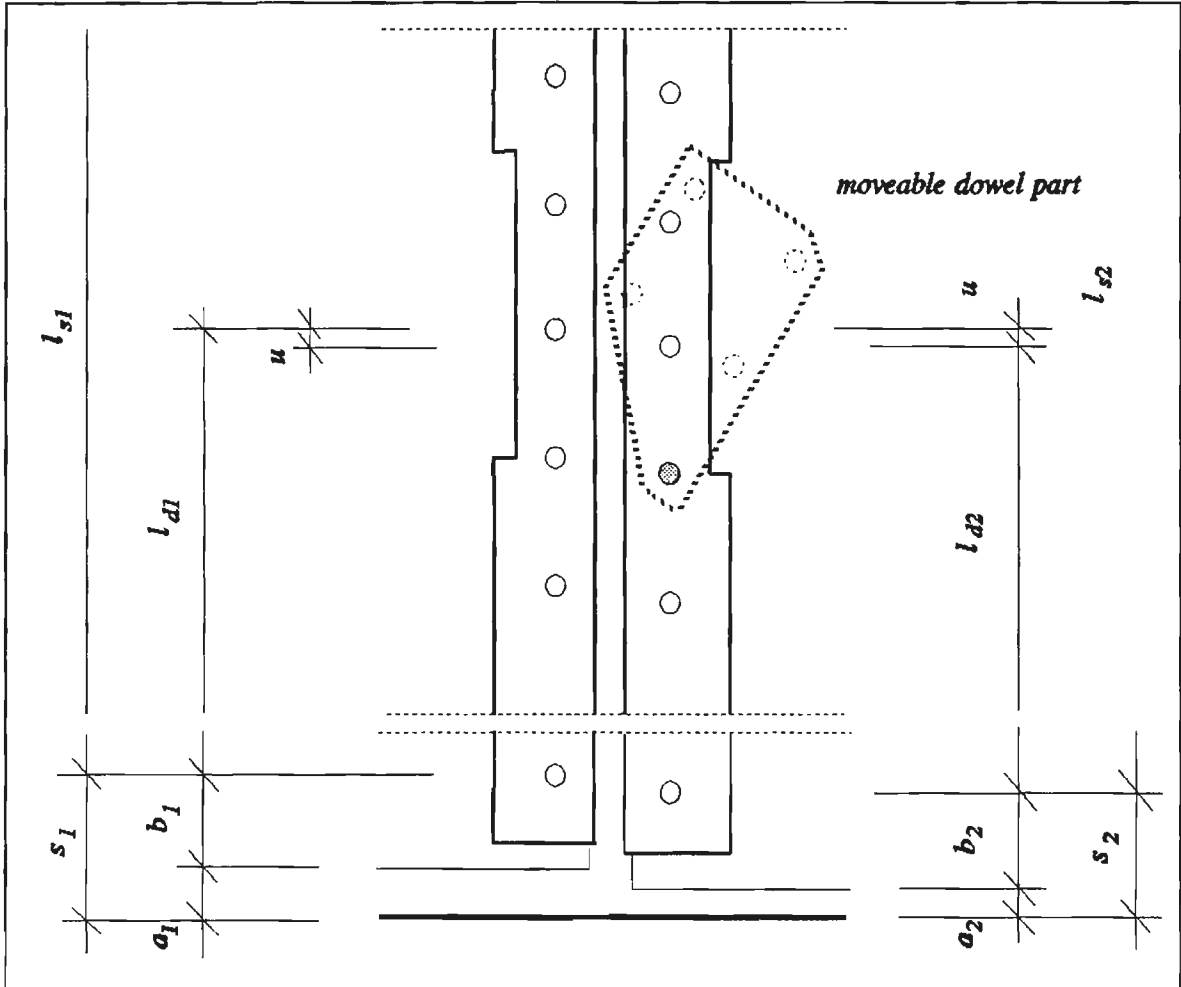

Fig. 5.2 Dowel part.

5.1.2 Theoretical model

Classification of dimensions:

Constituent dimensions: $a_1, a_2, b_1, b_2, l_{d1}, l_{d2}$, all independent.

Resultant dimensions: u .

Basic equations:

$$u = a_1 + b_1 + l_{d1} - a_2 - b_2 - l_{d2}$$

Equations for accuracy characteristics of the resultant dimensions:

5. Dowel connections

Equations for accuracy characteristics follows from the above basic equations and general principles described in Section 2. It is assumed that the constituent dimensions differing by subscripts 1 and 2 only have the same accuracy characteristics; therefore these subscripts are further on omitted. Furthermore it follows from the general rules, that systematic deviations of the resultant dimension u is zero and need not to be considered.

Equation for limit deviations:

$$\delta^2 u = 2^2 (\delta^2 a + \delta^2 b + \delta^2 l_d).$$

5.1.3 Analysis

Accuracy characteristics of constituent dimensions, given in table 5.1, are taken from Section 3.3. As in previous analyses two sets of input data are considered for lower and higher accuracy of production. Systematic and limit deviations of the dimensions l_{d1} and l_{d2} are assumed to be the same as for the lengths l_f and l_s and heights h_v and h_s in previous Section 3.3. For the dimensions b_1 and b_2 considered characteristics corresponds to the variant b) of assembling the floor components and to the coefficient of correlation $r_b = 0.5$ (see table 4.2).

Table 5.1 Accuracy characteristics of constituent and resultant dimensions.

Dimensions	Type of dimension	Accuracy	
		lower	higher
a_1, a_2	constituent	1.0 ± 1.0	0.5 ± 0.5
b_1, b_2	constituent	0.0 ± 1.6	0.0 ± 0.8
l_{d1}, l_{d2}	constituent	0.0 ± 1.0	0.0 ± 0.5
u	resultant	0.0 ± 3.0	0.0 ± 1.5

As already mentioned systematic deviations of all constituent dimensions zero. Systematic deviations of all constituent dimensions except a_1, a_2 are zero. As in Section 3.3, it is expected that there might be some systematic deviations of the hat profile height and also of above joint widths due to presumed production procedure. Relevant data should be determined using appropriate experimental data. Considered systematic deviations are only assessed. Nevertheless, as follows from the above results, this uncertainty is irrelevant for the analyzed assembly of dowel connection of two neighbouring wall components.

5. Dowel connections

The resulting accuracy characteristics of the dimension u , given in table 5.1, indicate some risks of misfit of holes in dowel part, attached to one component, and holes in dimple of the neighbouring component. For assumed input data this misfit could be from 1.5 mm (lower accuracy) to 3 mm (upper accuracy). Therefore it is necessary to design the holes somehow greater than the diameter of bolts. However, in case of greater holes than bolts, the dowel part attached to one component by the same bolts could freely moved by the difference of both diameters and would reduced the necessary difference to one half.

This would mean that the diameter of bolts, which could be "freely" inserted into any opening, is uttermost equal to the diameter of the holes reduced by one half of the above misfits. In other words in order to use the intended diameter of the bolts, the holes should be approximately 1 mm (higher accuracy) or 1.5 mm (lower accuracy) greater than bolts.

5.1.4 Conclusions and recommendations

The following conclusions and recommendations can be drawn from the above analysis.

- A - For assumed input data misfit of holes in dimples two neighbouring wall components could be as high as 1.5 mm to 3 mm .
- B - In order to avoid possible misfit, the diameter of holes in dimples should be greater at least by 1 mm , than intended diameter of bolts.
- C - It is highly recommended to verify input data describing dimensional deviations of the joints between hat profiles and wall components.

5.2 Connection of two floor components

5.2.1 Representative assembly

Typical joint of two floor components in horizontal direction, shown in Fig. 4.1, is described in Section 4.1. For two sets of neighbouring floor components, distinguished by subscripts 1 and 2 only, the assembly is schematically indicated in Fig. 5.3.

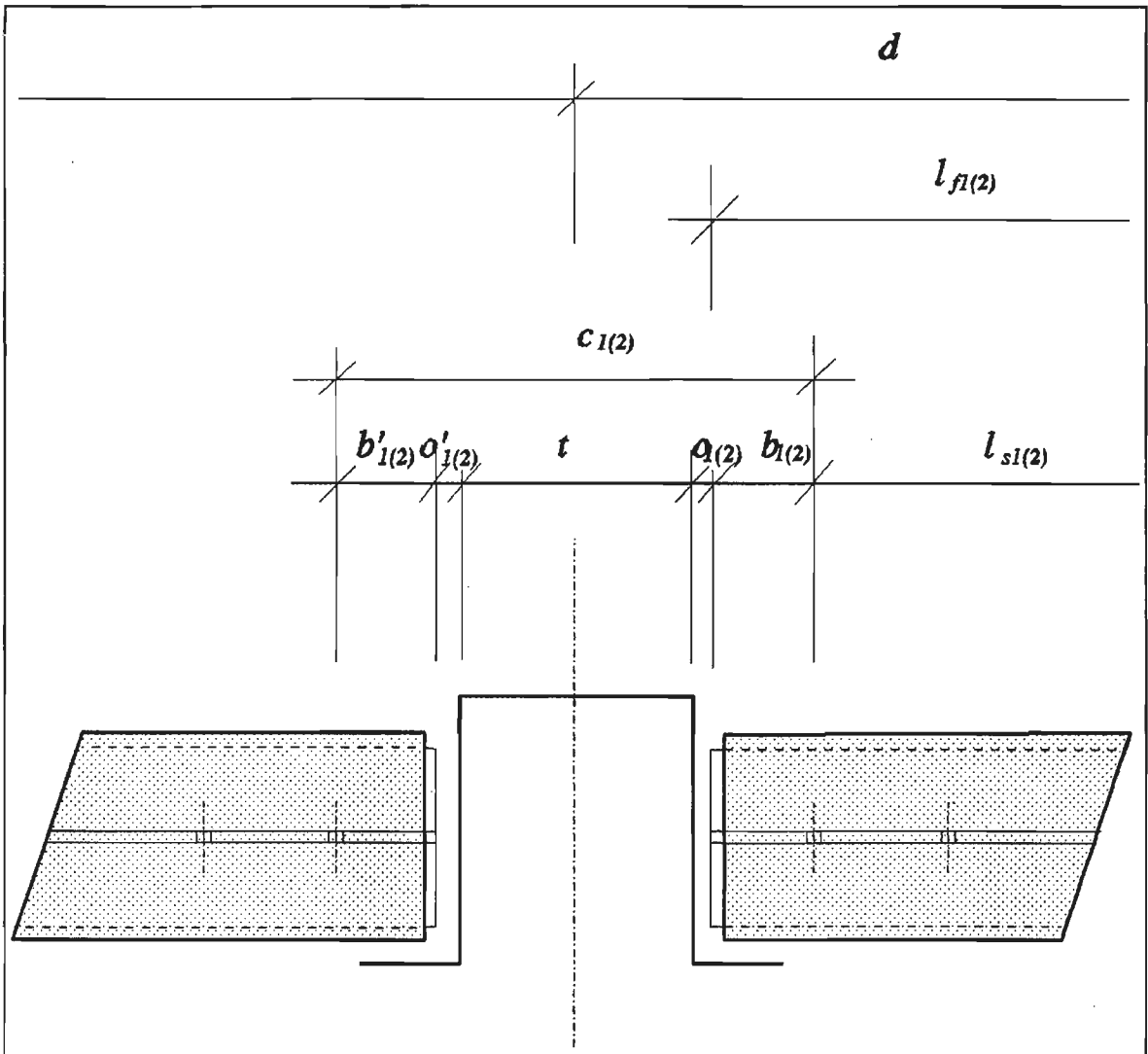

Fig. 5.3 Joint of floor components and a hat profile.

5. Dowel connections

Floor components left and right of the middle hat profile are located within distances $o'_{1(2)}$ and $o_{1(2)}$ from side walls of the hat. The left hand side components have the first holes in the dimples of their side parts located within distances $b'_{1(2)}$ from their right edges, the right hand side components have the first holes located within distances $b_{1(2)}$ from their left edges. Detail analyses of floor components assembly, using horizontal coupling strips, is given in Section 4.1.

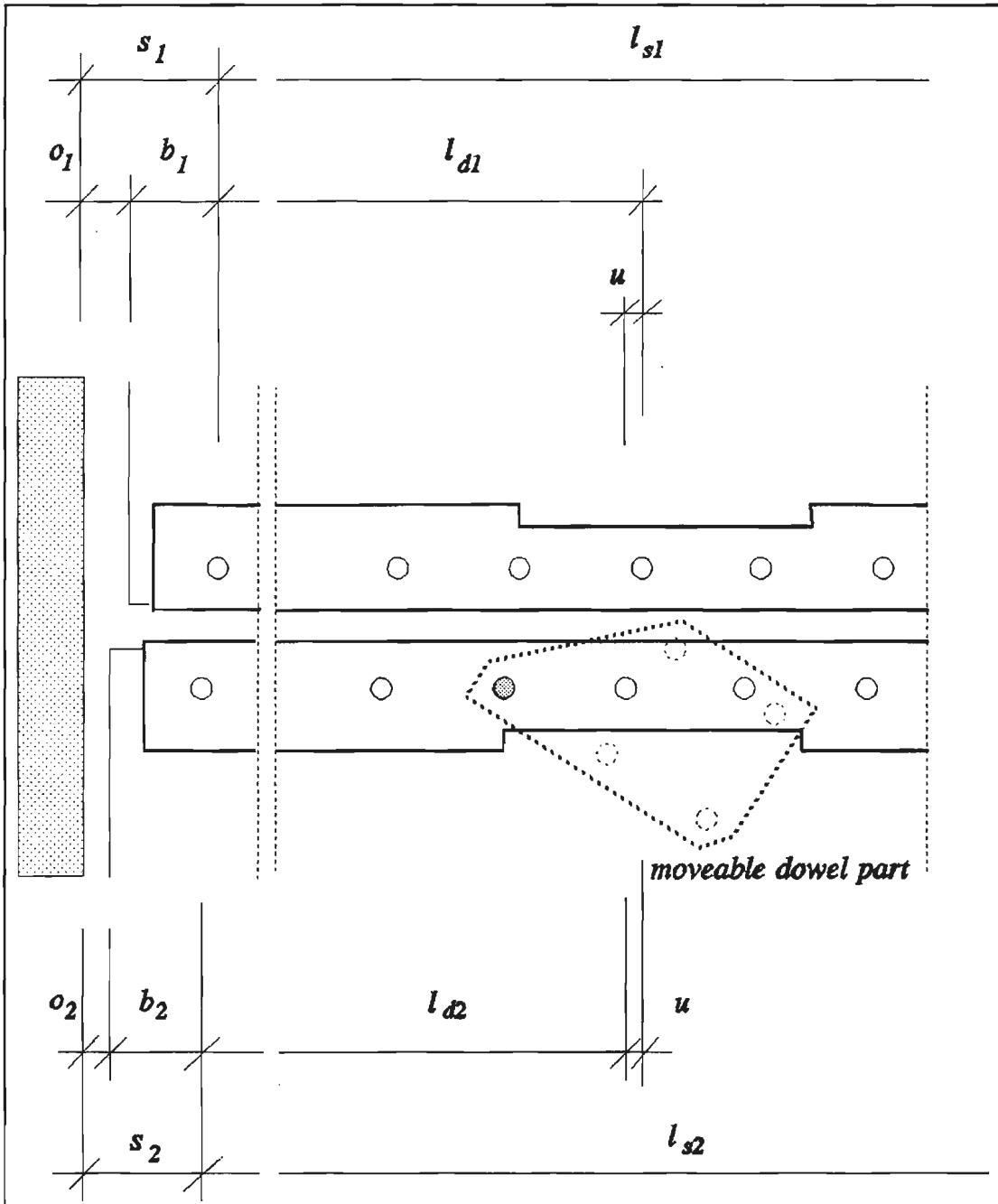

Fig. 5.4 Dowel connection of floor components.

5. Dowel connections

The following analyses of dowel connection of floor components concerns only two neighbouring components on one side (say right hand side in accordance with Fig. 5.3), for which the plan view is indicated in Fig. 5.4. Obviously, analogous conditions would be obtained for the components on the other side components. Accuracy characteristics of appropriate constituent dimensions are taken from previous Section 4.1.

5.2.2 Theoretical model

Classification of dimensions:

Constituent dimensions: $o_1, o_2, b_1, b_2, l_{d1}, l_{d2}$, all independent.

Resultant dimensions: u .

Basic equations:

$$u = o_1 + b_1 + l_{d1} - o_2 - b_2 - l_{d2}$$

Equations for accuracy characteristics of the resultant dimensions:

Equations for accuracy characteristics follows from the above basic equations. It is assumed that the constituent dimensions differing by subscripts 1 and 2 only have the same accuracy characteristics; therefore these subscripts are further on omitted. Furthermore it follows from the general rules, that systematic deviations of the resultant dimension u is zero.

Equation for limit deviations:

$$\delta^1 u = 2^1 (\delta^1 o + \delta^1 b + \delta^1 l_d)$$

5.2.3 Analysis

Accuracy characteristics of constituent dimensions, given in table 5.2, are taken from Section 4.1. As in previous analyses two sets of input data are considered for lower and higher accuracy of production. Systematic and limit deviations of the dimensions l_{d1} and l_{d2} are assumed to be the same as for the lengths l_1 and l_2 , and heights h_v and h_s , in previous Section 4.1 and 3.3. For the dimensions b_1 and b_2 considered characteristics

5. Dowel connections

corresponds to the variant b) of assembling the floor components and to the coefficient of correlation $r_b = 0.5$ (see table 4.2).

Table 5.2 Accuracy characteristics of constituent and resultant dimensions.

Dimensions	Type of dimension	Accuracy	
		lower	higher
o_1, o_2	constituent	$x/2 \pm 2.1$	$y/2 \pm 1.1$
b_1, b_2	constituent	0.0 ± 1.6	0.0 ± 0.8
l_{d1}, l_{d2}	constituent	0.0 ± 1.0	0.0 ± 0.5
u	resultant	0.0 ± 4.0	0.0 ± 2.0

The systematic deviation of all constituent dimensions, except the joint widths o_1 and o_2 , are zero. Similarly as in Section 4.1, it is expected that there might be some systematic deviations of the hat profile width t and consequently of above joint widths due to presumed production procedure. Relevant data should be determined using appropriate experimental data. For the time being, the unknown quantities x and y , which are introduced to indicate this uncertainty, may be considered to be approximately zero. However, it follows from the above results, that this uncertainty is irrelevant for the analyzed assembly of dowel connection of two neighbouring floor components.

The resulting accuracy characteristics of the dimension u , given in table 5.2, indicate again some risks of misfit of holes in dowel part, attached to one component, and holes in dimple of the neighbouring component. For assumed input data this misfit could be relatively high, approximately from 2.2 mm to 4.0 mm. Therefore it is necessary to design the holes somehow greater than the diameter of bolts. However, similarly as in Section 5.1, in case of greater holes than bolts, the dowel part attached to one component by the same bolts could freely moved by the difference of both diameters and would reduced the necessary difference to one half.

This would mean that the diameter of bolts, which could be "freely" inserted into any opening, is uttermost equal to the diameter of the holes reduced by one half of the above misfits. In other words, in order to use the intended diameter of the bolts, the holes should be 1.1 mm (higher accuracy) or 2.0 mm (lower accuracy) greater than bolts.

5. Dowel connections

5.2.4 Conclusions and recommendations

The following conclusions and recommendations can be drawn from the above analysis.

- A - For assumed input data misfit of holes in dowels and neighbouring components could be as high as 2.2 mm to 4.0 mm.
- B - In order to avoid possible misfit, the holes in dimples should be by 2 mm, in case of higher accuracy at least by 1.5 mm greater than intended diameter of bolts.
- C - It is highly recommended to verify input data describing dimensional deviations of the joints between hat profiles and floor components.

6 SHEAR WALLS

6.1 Representative assembly

A typical assembly of two shear walls in the bearing structure is schematically indicated in Fig 6.1.

The theoretical position of dimples is shown in Fig. 6.1 by thin lines, actual shape by thick lines. Two, left and right, shear walls, of the heights h_l and h_r , widths w_l and w_r , are assumed to be placed in such a way, that bottom edges fit the dimples of lower floor components. Horizontal floor components are supported by left, middle and right hat profiles, which elevations are denoted e_l , e_m , e_r in lower floor and e'_l , e'_m , e'_r in the upper floor. Notations of other symbols follows similar rules: subscripts are derived from the words left, middle and right, primes " ' " denote dimensions describing the next upper floor. As a rule dimensions, differing by subscripts only, suppose to have the same accuracy characteristics.

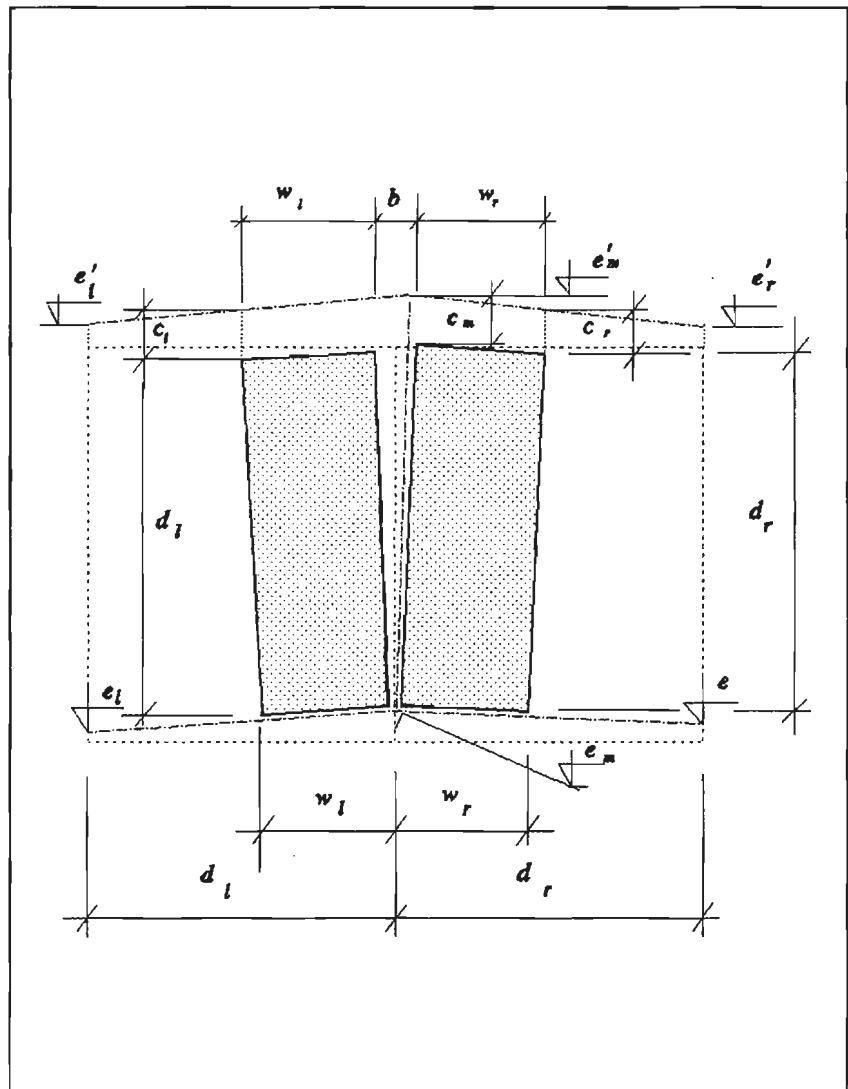

Fig. 6.1 Shear walls.

Critical dimensions describing resulting inaccuracies of the assembly are represented by unintended widths of joints of the shear walls of one floor, denoted in fig 6.1 by the dimension b , and by horizontal gaps between shear walls of two different

6 Shear walls

floor, denoted by the dimensions c_l , c_r , c_t . Considered input data are partly the same as before, partly results of investigations in previous chapters.

New aspect of this assembly compare to previously investigated assemblies is two dimensional character of shear walls, shown schematically in Fig. 6.2.

Bent edges of the shear walls should be placed into the side dimples of bearing components and fastened together by bolts inserted into the holes in the edges and dimples. There is, however considerable uncertainty that due to various dimensional inaccuracies the wall edges of two walls shall neither fit together, nor they fit the dimples. The aim of the following analysis is therefore to verify effects of foreseen dimensional deviations and to recommend possible measures to avoid expected construction difficulties. Possible dimensional deviations of these components are described by the two fundamental dimensions, the height h and the width w . However the actual shape of shear walls may be more complicated than a rectangle; deviation from right angle may be described by skewness s as indicated in Fig. 6.2. Other dimensional deviations like crooked edges, uneven surfaces non parallel edges etc., may be also taken into account [1], if appropriate data obtained by measurements and practical experiences are available.

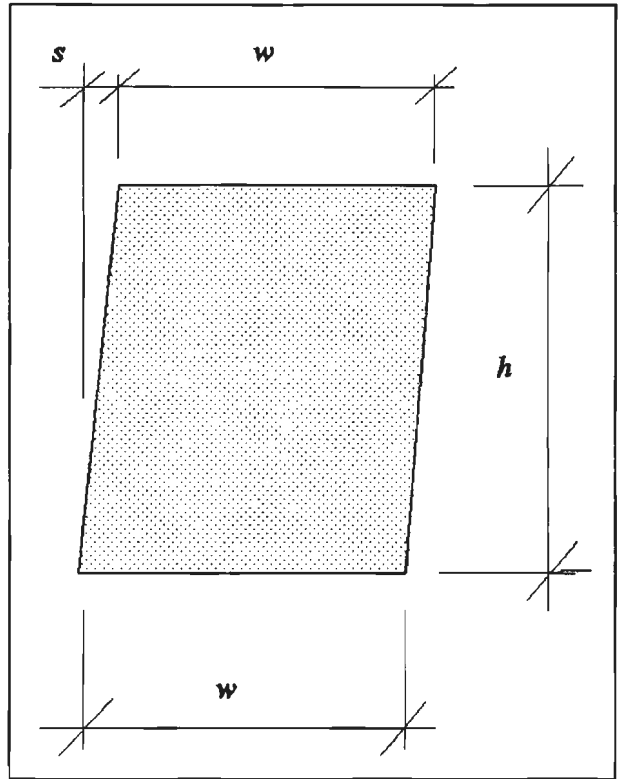

Fig. 6.2 A shear wall.

6.2 Theoretical model

Classification of dimensions

Constituent dimensions: e_l , e_r , e'_l , e'_r , h_l , h_r , d_l , d_r , d'_l , d'_r , w_l , w_r , w'_l , w'_r , all assumed to be mutually independent.

Resultant dimensions: c_l , c_r , b .

Auxiliary quantities denoting inclination of floor components related to the horizontal level:

$$\begin{aligned}\alpha_r &= (e_r - e'_r)/d_r, \\ \alpha_l &= (e_l - e'_l)/d_l, \\ \alpha'_r &= (e'_r - e''_r)/d'_r, \\ \alpha'_l &= (e'_l - e''_l)/d'_l.\end{aligned}$$

Basic equations

The following basic equations can be derived from Fig. 6.1.

$$\begin{aligned}c_r &= e'_r - e_r - h_{r(l)}, \\ c_l &= c_r + (\alpha_l - \alpha'_l)w_l, \\ c_r &= c_l - (\alpha_r + \alpha'_r)w_r, \\ b &= \alpha_r h_r - \alpha_l h_l.\end{aligned}$$

Equations for characteristics of resultant dimensions

As already indicated in Section 6.1, some simplifying assumptions concerning accuracy characteristics of constituent dimensions are accepted in the following analysis. First the reference values of similar constituent dimensions are assumed to be equal:

$$\begin{aligned}d_{rR} &= d_{lR} = d'_{lR} = d'_{rR} = d_R, \\ h_{lR} &= h_{rR} = h_R, \\ w_{lR} &= w_{rR} = w'_{lR} = w'_{rR} = w_R.\end{aligned}$$

Systematic deviations of all these dimensions are supposed to be zero. Furthermore the limit deviations of some comparable dimensions differing by the subscripts only are the same:

$$\begin{aligned}\delta e_r &= \delta e_l = \delta e'_r = \delta e, \\ \delta e'_r &= \delta e'_l = \delta e''_r = \delta e', \\ \delta h_l &= \delta h_r = \delta h.\end{aligned}$$

Then it follows that $\delta\alpha_r = \delta\alpha_l = \delta\alpha$,

$$\delta\alpha'_r = \delta\alpha'_l = \delta\alpha'.$$

Accuracy characteristics of auxiliary quantities

In view of the above assumptions all the auxiliary quantities have zero systematic deviations and the same limit deviation:

$$\delta^2 \alpha = 2\delta^2 e/d_R,$$

$$\delta^2 \alpha' = 2\delta^2 e'/d_R,$$

where effect of limit deviation δd is neglected as the ratio $\delta d/d_R$ is very small and therefore the reference value d_R is used only.

Accuracy characteristics of resultant dimensions

Systematic deviations of resultant dimensions follow from the above assumptions and general principles described in Sections 2.2 and 2.3 as:

$$\delta c_{lc} = \delta c_{rlc} = \delta c_{rc} = \delta e'_{rlc} - \delta e_{rlc},$$

$$\delta b_c = \delta \alpha_c h_R - \delta \alpha_c h_R = 0.$$

The limit deviations of resultant dimensions follow from the above assumptions and again from general principles described in Sections 2.2 and 2.3:

$$\delta^2 c_l = \delta^2 e'_l + \delta^2 e_l + \delta^2 h,$$

$$\delta^2 c_l = \delta^2 c_r = \delta^2 c_l + (\delta^2 \alpha + \delta^2 \alpha') w_R^2 =$$

$$= \delta^2 c_l + 2(\delta^2 e + \delta^2 e') w_R^2/d_R^2,$$

$$\delta^2 b = 2\delta^2 \alpha h_R = 4\delta^2 e h_R^2/d_R^2.$$

In the last two equations effects of limit deviations δw and δh are neglected as the ratios $\delta w/w_R$ and $\delta h/h_R$ are insignificant.

6.3 Analysis

Accuracy characteristics of constituent dimensions are given in Table 6.1. As before two sets of input data are considered. Systematic and limit deviations of the elevations e_l, e_0, e_r and e'_l, e'_0, e'_r are taken from previous Table 3.2 for the last possible storey, i.e. for dimensions e_l and e_r . As indicated above for the dimensions d_l, d_r and w_l, w_r only the reference values d_R and w_R are needed. Possible skewness of shear walls s (see Fig. 6.2) and other shape inaccuracies of the shear walls are not at present explicitly taken into account, their effects could be, however, very approximately considered by enhancement of limit deviations for the fundamental walls dimensions w and h , which has not been done. In case of necessity, more accurate analysis should be performed in view of new data additionally.

Table 6.1 Accuracy characteristics of constituent dimensions.

Dimensions	Accuracy	
	lower	higher
$e_l, e_0, e_r,$	8.0 ± 4.7	4.0 ± 2.2
e'_l, e'_0, e'_r	10.0 ± 5.1	5.0 ± 2.5
h_l, h_r	$h_R \pm 2.0$	$h_R \pm 1.0$
d_r, d_l, d'_r, d'_l	d_R is needed only	
w_r, w_l, w_j, w_f	w_R is needed only	

Accuracy characteristics of resultant dimension c_l, c_l, c_r and b , derived from the above input data using general relationships described in Sections 2.2 and 2.3, are given in Table 6.2. The following ratios of reference values are considered:

$$h_R/d_R = 3.6/4.2 = 0.86,$$

$$w_R/d_R = 1.2/4.2 = 0.29.$$

Table 6.2 Accuracy characteristics of resultant dimensions.

Dimensions	Accuracy	
	lower	higher
c_r	2.0 ± 7.2	1.0 ± 3.5
c_l, c_r	2.0 ± 8.3	1.0 ± 3.8
b	0.0 ± 8.1	0.0 ± 3.8

The resulting accuracy characteristics given in table 6.2 indicate some important risks of misfit. First the systematic deviations of the dimensions c_l, c_l, c_r , which follow from systematic deviations of storey height analyzed in Section 3, confirm that either the vertical bearing components should be shortened or the shear walls should be by the same magnitude enlarged. The first solution is certainly preferable in view of fitting other parts of the structure.

Probably more alarming outcome concerns limit deviations of all resultant dimensions, which are of the order of 4 mm in case of higher accuracy of production and of the order of 8 mm in case of lower accuracy of production. These value clearly indicate that there is a considerable risk of misfit of shear walls edges of adjacent components as well as shear walls edges and dimples of surrounding vertical and horizontal components. Furthermore, there may be also serious problems in fitting the holes in the walls edges of different components and dimples.

In view of obtained results it seems to be purposeful to redesign the shear walls. One of the possible solutions, which would entirely avoid misfit problems, consists in splitting shear walls in two different parts, which would be delivered separately and interconnected by suitable joint technique in situ. According to that solution the first type of parts (large ones) consists of flat plates with one (the longer vertical one) circumferential bent edge. The second type of parts (smaller horizontal ones) are interconnecting segments with central strips fitting the dimples. Both parts could be connected in situ by overlapping strips and spot welding in accordance to the actual shape of surrounding dimples. Demountability of shear walls could be still secured by eventual exchange (if necessary) of smaller (horizontal) interconnecting parts.

As in previous cases, it should be noted that the input data may not fit well the actual accuracy of production and it is highly recommended, especially in this case of very sensitive shear wall problem, to support the analysis by relevant measurements and/or newly becoming practical experience.

6.4 Conclusions and recommendations

The following conclusions and recommendations can be drawn from the obtained results.

- A - Due to various dimensional deviations there is considerable risk of mutual misfit of the adjacent shear walls and surrounding bearing structure including possible misfit of holes in the circumferential edges of walls and holes in the dimples of vertical and horizontal components.
- B - The vertical bearing components should be shortened by 1 or 2 mm (in accordance with the actual accuracy of production) in order to vanish systematic deviations in vertical direction.
- C - Deviations from correct locations of critical points could be expected within limit deviations ± 4 and ± 8 mm according to actual accuracy of production.
- D - To avoid entirely misfit problems of shear walls it is recommended to divide each shear wall into two types of different parts, which would be delivered separately and interconnected in situ in accordance with actual shape of surrounding dimples.
- E - It is highly recommended to verify all accuracy characteristics of constituent dimensions using measurements data and possibly adjust recommended splitting of shear walls into separate parts in accordance with practical experiences.

7 CONCLUSIONS

Practical conclusions and recommendations concerning individual representative assemblies of the industrial building system in detail are offered at the end of above Sections of that report. General conclusions and recommendations, which may be drawn from the submitted study as a whole, and which include also proposal for measurements and further investigation of dimensional accuracy of the system, are concentrated into the following points.

- A - Both induced deviations as well as deterministic and random components of time dependent deformations should be taken into account when analyzing dimensional deviations of the industrial building system.
- B - Analysis of any structural assembly of the industrial building system is purposeful to divide into the following four parts:
 - Representative assembly.
 - Theoretical model.
 - Analysis.
 - Conclusions and recommendations.
- C - Representative assemblies and theoretical models must be sensitively related to actual construction procedures and technological possibilities of erection and rectification of prefabricated components. Revised analysis should be executed whenever new experiences and relevant input data are available.
- D - Construction details should be designed in such a way as to avoid possible difficulties at assemble as well as at service stage of a structure. In case of shear walls, it is recommended to use overlapping rather than face contact joints whenever possible.
- E - A special attention should be payed to design and verification of actual accuracy of several contact joints of zero intended thickness, for which some positive systematic as well as limit deviations are foreseen in the above analyses.
- F - So called positional redundant erection is generally recommended to apply when assembling wall and floor components and when erecting horizontal components on bearing vertical components. Erected components or parts should be always placed symmetrically with

7 Conclusions

respect to remaining structure or parts of components. Actual accuracy characteristics of that procedure should be however verified by practical achievements.

- G - Measurements of actual components and their parts are urgently needed. The following items seems to be the most important:
- control measurements of setting out point in horizontal as well as vertical direction,
 - length of wall and floor components,
 - dimensions characterising assembly of side and main parts of wall and floor components including locations of critical holes in dimples,
 - both dimensions of shear walls, including their skewness or deviations from right angle,
 - control measurements of assembled structures and their parts and joints in vertical as well as in horizontal directions, including construction heights, spans, verticalities and joints of hat profiles with floor components.
- H - It is proposed to establish a research project systematically evaluating control measurements of actual induced deviations (manufacturing of components, setting out and erection) as well as to expected structural deformations (due to loads at various construction and service stages). Results of this project supplemented by practical experiences will best indicate demands for further analysis including modification of applied theoretical models and investigation of new assemblies including structural details and joints.

REFERENCES

- [1] M. Vorlicek and M. Holický: Analysis of dimensional accuracy of building structures, Elsevier, Amsterdam 1989.
- [2] J.O. Bats and J.F.G. Janssen: Industrialized housing with sheet-steel elements, In. Ninth International Conference on Cold-Formed Steel Structures, St. Louis, Missouri, U.S.A., November 1988.
- [3] EURONORN 162-81, Cold rolled sections. Technical conditions of delivery.

LIST OF FIGURES

	Page number in Sections, total
Fig. 2.1 Sources of dimensional deviations.	2 - 1 7
Fig. 2.2 Accuracy characteristics.	2 - 2 8
Fig. 2.3 Accuracy analysis procedure.	2 - 9 15
Fig. 3.1 Typical vertical assembly.	3 - 1 16
Fig. 3.2 Possible shape deviations of a hat profile.	3 - 2 17
Fig. 3.3 Deviations of floor elevations.	3 - 5 20
Fig. 3.4 Infill components.	3 - 7 22
Fig. 3.5 Vertical joint.	3 - 8 23
Fig. 3.6 Assembly of a wall component.	3 - 12 27
Fig. 3.7 A wall component.	3 - 13 28
Fig. 4.1 Floor components.	4 - 1 33
Fig. 4.2 Horizontal joint.	4 - 2 34
Fig. 4.3 The extreme location of holes.	4 - 3 37
Fig. 4.4 Assembly of floor components.	4 - 9 41
Fig. 4.5 Assembly of floor components.	4 - 10 42
Fig. 5.1 Wall components.	5 - 1 48
Fig. 5.2 Dowel part.	5 - 2 49
Fig. 5.3 Joint of floor components and a hat profile.	5 - 5 52
Fig. 5.4 Dowel connection of floor components.	5 - 6 53
Fig. 6.1 Shear walls.	6 - 1 57
Fig. 6.2 A shear wall.	6 - 2 58

LIST OF TABLES

Page number
in Sections, total

Table 3.1	Accuracy characteristics of constituent dimensions.	3 - 4	19
Table 3.2	Accuracy characteristics of resultant dimensions.	3 - 4	19
Table 3.3	Accuracy characteristics of the constituent dimension k .	3 - 9	24
Table 3.4	Accuracy characteristics of all constituent dimensions.	3 - 10	25
Table 3.5	Accuracy characteristics of resultant dimensions.	3 - 10	25
Table 3.6	Accuracy characteristics of constituent dimensions.	3 - 15	30
Table 3.7	Accuracy characteristics of resultant dimensions.	3 - 16	31
Table 4.1	Accuracy characteristics of constituent dimensions.	4 - 6	38
Table 4.2	Accuracy characteristics of resultant dimensions.	4 - 7	39
Table 4.3	Accuracy characteristics of constituent dimensions for $k = 1, 2, 3$.	4 - 13	45
Table 4.4	Accuracy characteristics of resultant dimensions.	4 - 14	46
Table 5.1	Accuracy characteristics of constituent dimensions.	5 - 3	50
Table 5.2	Accuracy characteristics of resultant dimensions.	5 - 8	55
Table 6.1	Accuracy characteristics of constituent dimensions.	6 - 5	61
Table 6.2	Accuracy characteristics of resultant dimensions.	6 - 5	61