

Short-circuit current limiters : literature survey 1973-1979

Citation for published version (APA):

Krause, J. C. (1980). *Short-circuit current limiters : literature survey 1973-1979*. (EUT report. E, Fac. of Electrical Engineering; Vol. 80-E-109). Technische Hogeschool Eindhoven.

Document status and date:

Published: 01/01/1980

Document Version:

Publisher's PDF, also known as Version of Record (includes final page, issue and volume numbers)

Please check the document version of this publication:

- A submitted manuscript is the version of the article upon submission and before peer-review. There can be important differences between the submitted version and the official published version of record. People interested in the research are advised to contact the author for the final version of the publication, or visit the DOI to the publisher's website.
- The final author version and the galley proof are versions of the publication after peer review.
- The final published version features the final layout of the paper including the volume, issue and page numbers.

[Link to publication](#)

General rights

Copyright and moral rights for the publications made accessible in the public portal are retained by the authors and/or other copyright owners and it is a condition of accessing publications that users recognise and abide by the legal requirements associated with these rights.

- Users may download and print one copy of any publication from the public portal for the purpose of private study or research.
- You may not further distribute the material or use it for any profit-making activity or commercial gain
- You may freely distribute the URL identifying the publication in the public portal.

If the publication is distributed under the terms of Article 25fa of the Dutch Copyright Act, indicated by the "Taverne" license above, please follow below link for the End User Agreement:

www.tue.nl/taverne

Take down policy

If you believe that this document breaches copyright please contact us at:

openaccess@tue.nl

providing details and we will investigate your claim.

th

Technical University of Technology
Netherlands

Department of Electrical Engineering

e

SHORT-CIRCUIT CURRENT LIMITERS

Literature Survey 1973-1979

by

J.C. Krause

Report No. 11-3-114

ISBN 90-316-116-4

E I N D H O V E N U N I V E R S I T Y O F T E C H N O L O G Y

Department of Electrical Engineering

Eindhoven

The Netherlands

SHORT-CIRCUIT CURRENT LIMITERS

Literature Survey

1973 - 1979

by

J.C. Krause

TH-Report 80-E-109

ISBN 90-6144-109-9

Eindhoven

July 1980

PREFACE

Before starting their Master degree projects, the students in the Department of Electrical Engineering of the Eindhoven University of Technology have to complete three "University assignments". This study was carried out to fulfill the requirements of such an assignment.

The rapidly growing interest in the covered subject makes it conceivable that the result might also be of use beyond the walls of this university.

Prof. W.M.C. van den Heuvel.

SUMMARY

This report contains the results of a literature study on short-circuit current limiters, covering the years 1973 - 1979. The method of investigation is described in Ch. I. In Ch. II the need for CLDs is explained; requirements for CLDs are collected and possible criteria for the distinction of the various principles are given.

The various ways in which fuses can be used for current limitation and their pros and cons are illustrated in Ch. III.

The transition in superconductors and metals between low and high impedance states implies its use in CLDs. Chs. IV and V review investigations on these fields; practical application of the principles meets large problems and no satisfactory results have been achieved yet.

When a.c. currents must be limited long before natural current zero, high-voltage d.c. (HVDC) interrupting principles may be successfully applied. The injection of a reverse current through the interrupter causes an artificial current zero. Vacuum and gas discharge tubes can interrupt large currents at high voltages. In either case the current commutates into a parallel impedance. These principles, described in Chs. VI and VII, appear to be very promising.

A limiting coil continuously connected in series with the current-carrying circuit is an old but still applicable method of limiting short-circuit currents. The Current Limiting Conductor, a new concept with variable reactance, offers new perspectives to this principle which is described in Ch. VIII.

Series resonance links which are brought out of tune when a short circuit occurs can limit short-circuit currents very effectively. Several advanced resonance circuits are treated in Ch. IX.

In Ch. X a comparison is made between the principles treated in this report and the latter are evaluated on the basis of economic and technical factors. In particular, attention is paid to reliability and to speed and degree of limitation. It appears that for every situation an economically attractive alternative is present.

CONTENTS

I	Introduction
II	Short-Circuit Current Limitation (General)
III	Fuses
IV	Superconduction
V	Temperature Dependent Limiters
VI	Current Injection
VII	Vacuum and Gas Discharge Tubes
VIII	Series Inductance
IX	Resonance Links
X	Evaluation
Appendix	Author Index

I. INTRODUCTION

This report contains the results of a literature investigation on short-circuit current limiters. The occasion for this is a research program performed in the group called Apparatus and Systems for Electrical Energy Supply of the Eindhoven University of Technology on a method of short-circuit current limiting. For this research the availability of a survey of the literature on this subject appeared desirable.

The concrete objective of this literature study is three-fold:

1. tracing literature on the subject;
2. arranging the literature according to the limiting principle;
3. mentioning and describing some typical systems.

In order to face the reader with the restrictions of this study, in the following a short survey will be given of the applied method and the process of the investigation. Next the domain of this study will be defined and the criteria employed will be mentioned.

Method and process of the investigation

The starting-point was an examination with the aid of the Electrical and Electronics Abstracts of Inspec ⁽¹⁾ over the years 1973-1979. Aiming at completeness, the subject index was consulted under the following headings, with which we tried to cover as many aspects of the subject as possible: air blast circuit breakers; circuit breakers; circuit breaking arcs; circuit resonance; commutation; cryotrons; current limiting reactors; electric fuses; fault currents; gas blast circuit breakers; gas discharge tubes; limiters; overcurrent protection; power system protection; saturable core reactors; short-circuit currents; superconducting devices; switches; switchgear; switchgear protection; vacuum tubes.

A further selection was made based on the given abstracts. The selected articles were looked up as far as possible and evaluated. References occurring in these articles were looked up as well as far as they seemed of importance for this study and as far as they were written after 1972. Very frequent references - also from before 1973 - were looked up in the

Science Citation Index ⁽²⁾ of the years 1973-1979 in order to check by whom they were cited in those years.

Finally, dissertations on the subject were looked up in the Dissertations Abstracts International B ⁽³⁾.

Domain and criteria employed

In 1973 Kruit ⁽⁴⁾ provided an extensive survey of the state of the development of short-circuit current limiters accompanied by an ample bibliography. Therefore we confined ourselves to the literature from 1973 to 1979.

Only journal and proceedings papers, dissertations (including M.Sc. theses) and reports were considered for this study. Books were not included for lack of current material. Patents were neglected as well, since their value was seriously questioned; after all, patents are mostly applied in an early stage where a useful evaluation is extremely difficult, and, moreover, commercial interests predominate. We trusted on valuable patents also being presented in journals and at conferences.

No consideration was given to articles in other languages than Dutch, English, German, French or Russian.

To allow for a proper selection, the following criteria were employed:

1. The literature must be related directly or indirectly to short-circuit current limitation in general or to a certain principle in particular.
2. Essential limitation of short-circuit currents must be implied.
3. Application in a.c. transmission and distribution networks for voltages of over 1 kV must be possible.
4. The literature must be of a sufficient engineering-scientific character and of an acceptable level.

It will occur to the reader that some articles are merely concerned with HVDC interruption. For some limiting principles, however, the development was originally centred on d.c. interruption; later on, the idea was adopted for a.c. limitation purposes. Neglecting these papers would cause a serious gap in the survey that this bibliography aims at giving on the development of the principles in question.

Set-up of the report

For each limiting principle a description of its basic operation is first given. Subsequently, the developments reflected in the literature cited are dealt with. Finally, one or more systems, typical of the present state of affairs, are described.

The bibliography consists of two parts; one part contains the literature consulted, and is supplied with short outlines. The other contains references to non-consulted literature, accompanied - if possible - by abstracts from Electrical and Electronics Abstracts or from other sources.

In the final chapter an attempt is made to evaluate the results of this investigation. The principles mentioned will be compared and some prudent conclusions will be drawn.

Acknowledgement

To Mr. ir. I.V. Brůža I am indebted for his help and advice during this study.

REFERENCES

- (1) ELECTRICAL AND ELECTRONICS ABSTRACTS.
INSPEC, Institution of Electrical Engineers, Hitchin,
Herts, England. 1973-1979.
- (2) SCIENCE CITATION INDEX.
Institute for Scientific Information, Philadelphia,
Penns. 1973-1979.
- (3) DISSERTATIONS ABSTRACTS INTERNATIONAL B: THE SCIENCES AND
ENGINEERING.
University Microfilms, A Xerox Company, Ann Arbor, Mich.
1973-1979.
- (4) Kruit, D.
METHODEN VAN STROOMBEGRENZING BIJ KORTSLUITING IN EEN
WISSELSTROOM NET (Methods of Short-Circuit Current
Limitation in A.C. Networks).
M.Sc. Thesis, Eindhoven University of Technology, Depart-
ment of Electrical Engineering, Group Apparatus and
Systems for Electrical Energy Supply, 1973. In Dutch.

II. SHORT-CIRCUIT CURRENT LIMITATION (GENERAL)

The electric power supply networks today are still faced with an exponential growth of the energy consumption. Both the proceeding increase in the power supply and the extension of networks and network interconnections contribute to the growth of short-circuit currents. A doubling every ten to twenty years has been estimated for concrete situations.

As an inevitable consequence, some present installations and circuit breakers will soon be insufficient to cope with the rapidly increasing short-circuit currents and the resulting mechanical and thermal overloads. New installations and circuit breakers will need to be replaced in ever faster succession.

Several possibilities exist to limit fault currents. One of those is the installation of a so-called Current Limiting Device (CLD), i.e. a series device which offers low impedance to load currents in its normal state, but acts rapidly to limit the instantaneous magnitude of fault currents to a predetermined level (7,8).

For effective operation the following restrictions should be imposed on CLDs (7):

1. The CLD must be extremely fast in operation.
2. Overvoltages as a result of its operation must be avoided.
3. Normal load current must pass without hindrance or noticeable voltage loss.
4. Power loss during normal operation should be minimized.
5. The CLD must be extremely reliable in operation.
6. Cost must be economically acceptable.

Often not all requirements can be met simultaneously; in those cases a compromise should be found which is most advantageous in the given situation.

Several authors have given criteria for the distinction and division of CLDs. McConnell et al. (5) give a broad essay based on the distinction between insertion of a resonance circuit, an inductive circuit or a resistive circuit. In addition Barkan (6) uses speed and degree of limitation as a criterion, according to which he divides CLDs into:

- A. devices which limit after the first natural current zero;
- B. devices which limit the first cycle fault current to $1/2$

or $1/3$ of the prospective peak fault current, and subsequent fault current to a prescribed lower level;

C. devices which limit instantaneously to a small multiple of the rated current.

Pros and cons are extensively described.

Since a consistent, systematic division is necessarily rough, this study uses a division which has its roots in an article of Beehler ⁽⁹⁾ but is modified for the sake of completeness and in view of recent developments. Seven items are distinguished:

1. fuses;
2. superconducting devices;
3. other temperature dependent devices;
4. current injection devices;
5. devices with vacuum or gas discharge tubes;
6. inductive devices;
7. resonance circuits.

Non-automatic limiters should be equipped with a device to sense the fault and actuate the limiter. Fransen ⁽¹³⁾ and Lee et al. ⁽¹⁴⁾ report on investigations of such fault sensors paying due attention to requirements concerning speed and reliability.

Many authors have made comparisons between several limiting principles. Only few have paid more than superficial attention to economic aspects. In this regard McConnell et al. ⁽⁵⁾ and Manders and van Hoek ⁽¹¹⁾ should be mentioned.

REFERENCES

- (5) McConnell, L.D., W.A. Donaldson and E.R. Perry.

FAULT CURRENT LIMITERS FOR ELECTRIC POWER SYSTEMS.

In: IEEE Power Engineering Society Winter Meeting, New York, N.Y., 27 Jan.-1 Febr. 1974.

New York: Institute of Electrical and Electronics Engineers, 1974. Paper C74177-2/1-9.

The elements required for a CLD are mentioned. For a general power system the economic effect of fault current levels is analyzed; attention is paid to circuit breakers, load capacity, system security and future system requirements. CLDs are divided into switched resonant circuits, switched inductive circuits and switched resistor circuits. The pros and cons of these and the problems encountered in future research are summed up.

- (6) Barkan, P.

SOME ALTERNATIVES FOR CURRENT LIMITING DEVICES FOR TRANSMISSION APPLICATIONS.

In: Symposium on Current Limiting Devices - IEEE Power Engineering Society Summer Meeting, Anaheim, Cal., 14-19 July 1974.

New York: Institute of Electrical and Electronics Engineers, 1975. Order no. 75CHO1037-1-PWR, p. 16-21.

Two criteria for CLDs are dealt with: the character of the limiting impedance and the speed and degree of limitation. Pros and cons of inductive and resistive impedance insertion are balanced against each other; preference is given to resistor insertion. Also with the latter criterion several possibilities are carefully compared.

- (7) Falcone, C.A.

CURRENT LIMITING DEVICES - NEED AND APPLICATION.

In: Symposium on Current Limiting Devices - IEEE Power Engineering Society Summer Meeting, Anaheim, Cal., 14-19 July 1974.

New York: Institute of Electrical and Electronics Engineers, 1975. Order no. 75CHO1037-1-PWR, p. 1-9.

First a description is given of the growth of short-

circuit currents in AEP's utility networks. Two applications of CLDs in the system are mentioned. Requirements for CLDs are described. As an example, the operation of the Switched Resistor Fault Current Limiter is briefly discussed. The restrictions and possibilities of the control circuit are considered. Long-term prospectives for CLDs are dealt with and an example is given to sustain the author's view.

- (8) Falcone, C.A., J.E. Beehler, W.E. Mekolites and J. Grzan.
CURRENT LIMITING DEVICE - A UTILITY'S NEED.
IEEE Trans. Power Appar. & Syst. PAS-93 (1974) 6, p. 1768-1775.

If today's trend in energy consumption will continue, short-circuit currents will grow exponentially in the future. With the aid of a simplified model it is shown how prospective short-circuit currents will exceed breaker capacities in the years 1980, 1990 and 2000. In the case of AEP's power system a numerical, statistical analysis is given, based on data collected in the past ten years. Replacement of present breakers by larger ones is rejected. As a useful solution the installation of CLDs is proposed. The term CLD is specified and a number of requirements is mentioned. Finally, the place of the CLD in the total system is being considered.

- (9) Beehler, J.E.

FUTURE BREAKERS.

In: 1976 IEEE Region 6 Conf. on Energy for the Future, Tucson, Ariz., 7-9 Apr. 1976.

New York: Institute of Electrical and Electronics Engineers, 1976. P. 94-98.

After limitation of the subject of this paper constraints are discussed which either impede the development of circuit breakers or force new design changes. Design criteria for future breakers are suggested, one of which is current limitation. A survey of present developments is provided and it is checked how far present breakers meet the requirements mentioned. In an appendix the CLDs under development or in use in 1976 are reviewed.

(10) Gels, H.B. and C. Reimann.

KURZSCHLUSS-STROMBEGRENZUNG IN INDUSTRIENETZEN MIT HOHER LAST (Short-Circuit Current Limitation in Industrial Power Systems with High Load).

BBC-Nachrichten (1976) 6-7, p. 268-274. In German.

First a survey of special problems occurring in industry networks and their consequences for short-circuit currents is given. For their limitation several CLDs are proposed. Alternatives to cope with the arising problems change the configuration of the networks and enlarge the capacity of the circuit breakers. Quoting an example, the authors illustrate the extension of the industrial network; short-circuit currents are calculated and concrete solutions are looked for in order to limit fault currents.

(11) Manders, A.H.E. and G.A.L. van Hoek.

MOGELIJKHEDEN VOOR DE BEGRENZING VAN KORTSLUITSTROMEN IN HOOGSPANNINGSNETTEN; ECONOMISCHE ASPECTEN (Possibilities for the Limitation of Short-Circuit Currents in High Voltage Networks; Economic Aspects).

In: KIVI leergang: Toekomstaspecten in de Elektrische Energievoorziening, Eindhoven, 13-14 Jan. 1976. In Dutch. 's-Gravenhage: Koninklijk Instituut van Ingenieurs, 1976. P. V/1-22.

The situation of the Dutch 380 kV network in 1990 is pictured. It turns out inevitable to take additional measures to control short-circuit currents. Requirements that should be met are summed up and a number of measures is mentioned and described. Further, additional complications that can be expected around 2000 are considered. Finally, the economic aspects are illustrated.

(12) Greenwood, A.

TECHNICAL APPROACHES TO THE SOLUTION OF SHORT-CIRCUIT CURRENT LIMITING IN POWER SYSTEMS.

In: KIVI leergang: Toekomstaspecten in de Elektrische Energievoorziening, Eindhoven, 13-14 Jan. 1976.

's-Gravenhage: Koninklijk Instituut van Ingenieurs, 1976. P. III/1-7.

Some problems of CLDs are indicated, referring to the

operation of the fuse. The following solutions are elaborated: (a) the insertion of a temperature dependent resistor; huge problems have hindered the application of this principle. (b) the Current Limiting Conductor: a device which can enlarge its inductivity by means of magnetic forces, but which by its inertia is still too slow for a.c. purposes. (c) current injection into a switch in order to create a rapid current zero. (d) application of a gas discharge tube triggered by a magnetic field.

(13) Fransen, H.J.F.L.M.

KORTSLUITSTROOMBEGRENZEND UITSCHAKELEN, I (Short-Circuit Current Limiting Switching).

M.Sc. Thesis, Eindhoven University of Technology, Department of Electrical Engineering, Group Apparatus and Systems for Electrical Energy Supply, 1976. In Dutch.

Many topics on the field of short-circuit current limitation are dealt with extensively. Several CLDs are described. In particular the control circuit for a CLD has been carefully analyzed.

(14) Lee, I., R. Carberry, W. Knauer, B.A. Benz and S.H. Horowitz.

AN ULTRAFast FAULT SENSOR FOR A FAULT CURRENT LIMITING DEVICE.

IEEE Trans. Power Appar. & Syst. PAS-98 (1979) 3, p. 1069-1079.

Requirements for a fault sensor concerning speed and distinction are presented. The authors state that switching on the basis of pure di/dt detection has severe disadvantages and is only attractive for multiple-phase fault detection. For single-phase detection the fault current is compared with a current from a fault simulator. Detection time is limited to about 0.4 ms. The sensor block diagram is given and the operation is explained. Experiments with single line-to-earth faults are described and results given.

Not consulted:

(15) Falcone, C.A.

LONG-RANGE TRENDS IN THE CHARACTER OF ELECTRIC POWER SYSTEMS.

Doctoral Thesis, Rensselaer Polytechnic Institute, Troy, N.Y., 1973.

University Microfilms Order no. 73-27,204.

(16) Neklepaev, B.N.

METHODS OF LIMITING SHORT-CIRCUIT CURRENTS IN POWER SYSTEMS.

Flektr. Stantsii (1973) 11, p. 69-72. In Russian.

Studies the various methods of current limitation practised in different countries. Although the thermal and electromagnetic phenomena associated with severe faults arise simultaneously, their consequences are displaced from each other in time, and the expedients that are best for dealing with the one may not be so effective for the other. Under present-day conditions a complex of current limiting systems is needed, tailored to suit the particular local conditions.

(17) Falcone, C.A.

CURRENT LIMITING - AN ALTERNATIVE APPROACH TO FAULT INTERRUPTION.

In: 1974 Winter Meeting of Pennsylvania Electric Association Relay Committee, 15 Febr. 1974.

(18) Barkan, P. and D.D. Wilson.

CURRENT LIMITING DEVICES FOR TRANSMISSION AND DISTRIBUTION APPLICATIONS.

In: Proc. American Power Conf., vol. 36, Chicago, Ill., 29 Apr.-1 May 1974.

Chicago: Illinois Institute of Technology, 1974. P. 1105-1113.

(19) Kenyon, R.

FAULT CURRENT LIMITERS: PROBLEMS AND PROSPECTS.

EPRI Journal 1 (1976) 1, p. 14-19.

(20) Gels, B. and C. Reimann.

EXTENDING NETWORKS EFFICIENTLY - SHORT-CIRCUIT CURRENT LIMITATION IN HIGH-CAPACITY NETWORKS.

Elektrotechnik 58 (1976) 19, p. 14-16, 18. In German.

When industrial networks are extended and capacity is increased, care should be taken to prevent the short-circuit rating of the switchgear from being exceeded. Possible solutions include the use of short-circuit current limiting reactors, suitable system rearrangement, modifications to cables/networks, and the use of higher rupturing capacity switchgear. Some of the solutions available are considered with reference to a particular example, suggestions are made for suitable courses of action, and the technical and economic aspects are discussed.

III. FUSES

Since long the fuse has been the most frequently used fault current limiter. Its applicability covers both low and high voltages. Important advantages of the fuse are its simple construction, low cost, automatic operation and lack of moving parts. As main disadvantages should be mentioned the need for replacement after every operation and the fact that in essence it provides no instantaneous current limitation but thermal limitation, characterized by the time integral i^2t , which causes time delay.

In principle a fuse consists of a silver wire in a sand-filled tube. When a load current passes through it, this wire forms a negligible resistance to the circuit. At a short circuit the wire is overheated and melts. Arcs are formed building up a countervoltage which limits the current. The main function of the sand is to cool the arc, thus improving the interrupting capacity.

In general, four limiting principles containing fuses can be distinguished (figure III-1):

- a. The fuse is the only element of the limiter.
- b. The fuse is in parallel with a resistor to which the current is commutated and in which the energy in the circuit can be dissipated.
- c. The fuse is in parallel with a fast mechanical or explosive switch which commutates the current into the fuse.
- d. The fuse is in parallel with both a fast switch and a resistor.

(a) Although this principle has always functioned satisfactorily in the case of low voltages, some problems appear at high voltages, which make it less attractive:

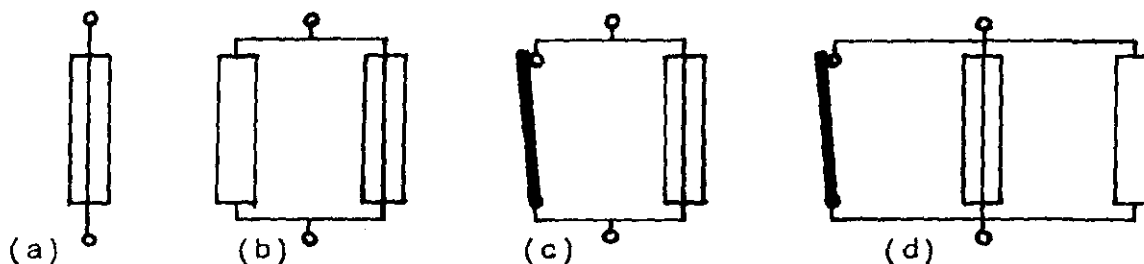

Figure III-1. Limiting principles with fuses.

- Since the fuse should melt very rapidly at the occurrence of a short-circuit, its heat capacity should be low. In order to dissipate the energy stored up in the load-side network a high heat capacity is required.
- The occurrence of high overvoltages may cause damage to the circuit.

The interest in this principle remains, mainly due to its simplicity and low cost. Research is heading for two goals: on the one hand a better theoretical understanding of the fuse's operation is aimed at, on the other, one tries to influence its operation by means of alternative shapes and constructions of wires (e.g. ribbons) and new filler compositions.

Hudis and Bhargava ⁽²⁵⁾ use a sand-resin mixture as a coolant; the interrupting capacity is thus increased. Further they introduce a new fuse construction, the so-called Expanded Diamond Ribbon. This results in better heat transfer, higher arc voltage and smaller ratio of critical to rated current. Their design is given in figure III-2.

(b) This principle gives a solution for the problems of the heat capacity of the fuse. Since the resistor dissipates the energy stored, the fuse may simply have a low heat capacity. When the fuse melts, the current commutates into the resistor; thus overvoltages are limited. By choosing an adequate value for the resistance, no arc is formed in the fuse and this increases the reliability of the limiter. It is applied in a project of the group called Apparatus and Systems for Electrical Energy Supply of the Eindhoven University of Technology. Further literature is lacking.

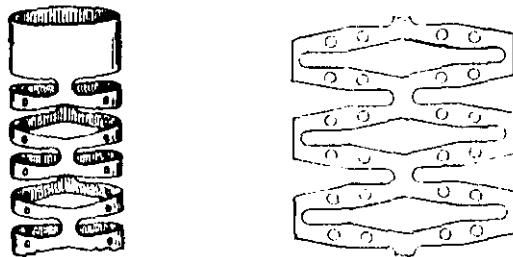

Figure III-2. Expanded Diamond Ribbon. From Hudis and Bhargava ⁽²⁵⁾.

(c) This principle gives an alternative solution for the problems mentioned at (a). Moreover, there are practically no losses during normal duty. The fuse now needs a high heat capacity combined with a low critical current which may be well below the rated current. Overvoltages caused by the opening of the switch are limited only to a certain extent.

A severe disadvantage of this principle is that it is not automatic in operation. Therefore fast and reliable control circuitry is required. Yet this principle is frequently applied, in particular in the so-called I_s -limiter, which uses an explosive switch in parallel to the fuse (36). Pflanz et al. (37) describe a similar circuit. Both designs are illustrated in figure III-3.

(d) The advantage of this principle compared to those mentioned above is a more effective limitation of overvoltages and a behaviour which can be predicted more accurately; it depends less on the fuse parameters.

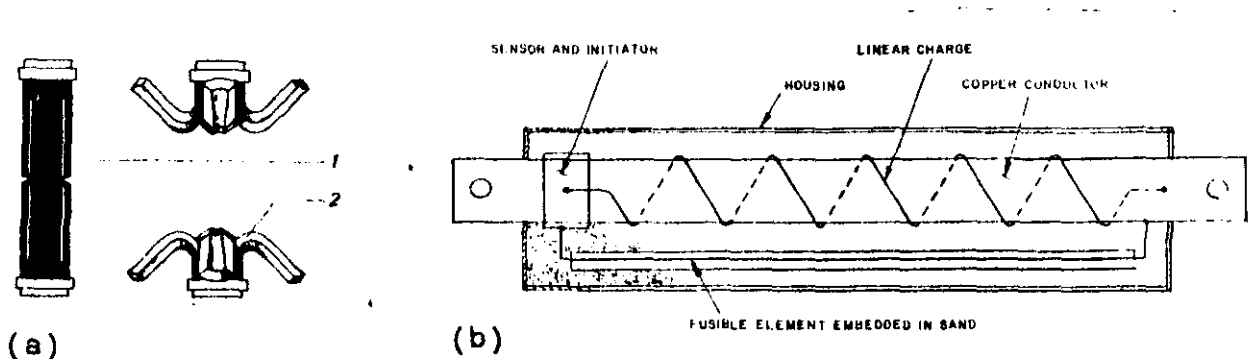

Figure III-3. CLDs with fuse and explosive switch in parallel. (a) from Keders and Leibold (36). (b) from Pflanz et al. (37).

REFERENCES

(a)

(21) Banas, K.P.

SUBMERSIBLE LOAD AND FAULT INTERRUPTING DEVICES 5.5 kV THROUGH 38 kV.

In: 1974 Underground Transmission and Distribution Conf., Dallas, Tex., 1-5 Apr. 1974.

New York: Institute of Electrical and Electronics Engineers, 1974. P. 628-632.

This paper describes a CLD which consists of a switch and back-up type current limiting fuse connected in series and immersed in oil. The design of the switch is discussed and experiments are described to illustrate its operation. The special feature of this device lead to some unique applications which are summed up briefly.

(22) Nichols, T.O.

CURRENT LIMITING FUSE EXTENDS PROTECTION LIMITS.

Electrical World 181 (1974) 7, p. 46-53.

Various types of fuse are mentioned. The operation of a fuse in general is described and a new design is introduced, bringing about some remarkable improvements of operation. Testing of fuses is dealt with and a comparison is made between limited energy and i^2t . Arc control is studied and compared for wire and ribbon elements. It is determined how CLDs and surge arresters can be matched safely for optimum operation. Finally, attention is paid to choosing the right type of fuse for a given situation.

(23) Vermij, L.

BEHAVIOUR OF SHORT FUSE-ELEMENTS ASSOCIATED WITH THERMAL EFFECTS.

Holectechneik 5 (1975) 3, p. 76-81.

The melting characteristic, the value of the action integral, and the cut-off current of a fuse can all be influenced considerably by varying the length of the fuse-element or the length of parts of it with a reduced cross-section. In this article are reported some investi-

gations regarding the influence of the length of a fuse-element on its properties related to the thermodynamic behaviour of a fuse, viz. the temperature, the energy dissipation under steady-state current conditions, the value of the action integral and the cut-off current.

- (24) Arndt, R.H. and E.J. Kotski.

ENERGY LIMITING CHARACTERISTICS OF CURRENT-LIMITING FUSES.

In: IEEE Power Engineering Society Summer Meeting, Portland, Or., 18-23 July 1976.

New York: Institute of Electrical and Electronics Engineers, 1976. Paper A76508-2, p. 1-4.

Describes the problems of excessive energy dissipation in power apparatus, in particular in transformers. The relation between dissipation and i^2t is illustrated. Parameters are brought forward that can be of importance when choosing fuses for specific applications.

- (25) Hudis, M. and B. Bhargava.

CURRENT LIMITING FUSE STUDY - NEW DESIGNS AND COMPOSITE SAND FILLERS.

In: IEEE Power Engineering Society Summer Meeting, Mexico City, Mex., 17-22 July 1977.

New York: Institute of Electrical and Electronics Engineers, 1977. Paper A77621-6, p. 1-8.

Two aspects of the fuse are studied, viz. the shape of the fuse and the composition of the filler. A new design is presented with an "Expanded Diamond Ribbon" fuse-element and a sand-resin mixture as filler. The effects of these changes on the operation of the fuse are studied.

- (26) Narancic, V., M. Braunovic and A.C. Westrom.

THE COMPOSITE FUSE - A NEW TECHNOLOGY FOR CURRENT LIMITING FUSES.

In: 7th IEEE Power Engineering Society Transmission and Distribution Exposition, Atlanta, Ga., 1-6 Apr. 1979.

New York: Institute of Electrical and Electronics Engineers, 1979. P. 462-469.

This paper reports on the results of investigations of a new type of fuse. First an attempt is made to give a

physical analysis of the interruption process. The required melting characteristics are indicated. Existing materials are tested on their electrothermal features and a new material, composed of zinc and aluminum, is proposed. The influence of the temperature coefficient and of the notch shape of the element on the let-through energy is determined. The dielectric system is improved by elimination of a core or other support for the wire. Some typical test results conclude this paper.

Not consulted:

(27) Vojnovich, T. and D.D. Blewitt.

THICK-FILM CURRENT LIMITING FUSES FOR POWER APPLICATIONS. Am. Ceram. Soc. Bull. 52 (1973) 8, p. 635. Abstract only.

Thick-film current limiting fuses based on conductive silver elements were fabricated as protective devices for power applications. The thick-film elements with and without constrictions were formed on tabular alumina substrates by several techniques. They demonstrated excellent current clearing performance on shorting currents ranging up to 28 kA. The relation between thick-film element design, heat transfer characteristics and clearing performance will be discussed.

(28) Lipski, T.

THEORETICAL PRINCIPLES OF HRC ELECTRIC FUSES DESIGN.

In: 2nd Int. Symposium on Switching Arc Phenomena, Pt. I, Lodz, Poland, 25-27 Sept. 1973.

Lodz, Poland: Tech. Univ. Lodz, 1973. P. 229-240.

On the basis of recently published experimental and analytical work a brief review is given of some methods that can be applied for calculating the following parameters of current limiting fuses: (1) minimum fusing and rated current; (2) operation characteristics; (3) short-circuit breaking processes; (4) overload current breaking processes.

(29) Young, B.

HRC FUSES REDUCE SHORT-CIRCUIT CURRENTS.

Mod. Power & Eng. 69 (1975) 3, p. 46-47.

Discusses the operation of HRC fuses which have the ability to reduce the available short-circuit current in an electrical system, increasing system safety and minimizing damage caused in the event of a short circuit. The fuses are thermal devices with an inherently high speed of operation. They are capable of snapping off the first major loop of short-circuit current before the full effect of the fault current can be felt and thus reduce automatically the thermal and magnetic forces stressing the system.

- (30) Popeck, C.A., W.A. Lewis and G.D. Allen.

THE APPLICATION OF CURRENT LIMITING TO DISTRIBUTION CIRCUIT PROTECTION.

Electr. Power Syst. Res. 1 (1977) 1, p. 67-86.

Studies the use of current limiting fuses to achieve more effective protection of the entire distribution system, including protection of distribution feeders at the substations. This approach also provides effective preventive measures to inhibit disruptive transformer failures which have become a severe problem with increasing short-circuit capability.

- (31) Withers, J.S.

CURRENT LIMITING FUSES AND ELECTRIC CIRCUIT THEORY.

In: 1977 IEEE Int. Conf. on Plasma Science, Troy, N.Y., 23-25 May 1977.

New York: Institute of Electrical and Electronics Engineers, 1977. P. 116. Abstract only.

To render circuit theory capable of explaining what a current limiting fuse must do to change a rising current into a decaying one, the required concepts are developed in a logical sequence from fundamental physical laws. A model of an ideal current limiting, zero-forcing fuse is described and an explanation of its performance is given in terms of the concepts which have been developed. The basic properties of an electric arc are discussed and compared with the requirements of the ideal current limiting, zero-forcing fuse. Finally, a cause-and-effect chart of the various events that lead to a fault-current interruption is shown.

(32) Inaba, T.

THE DEVELOPMENT OF A DIRECT-COOLED TUBULAR ELEMENT TYPE OF HIGH-RUPTURING CAPACITY CURRENT LIMITING FUSE.

In: 5th Int. Conf. on Gas Discharges, Liverpool, 11-14 Sept. 1978.

London: Institution of Electrical Engineers, 1978. IEE Conference Publication, no. 165, p. 202-206.

A high-speed current limiting fuse was studied as one measure of fault current protection for thyristors used in a.c. and d.c. substations. The entirely new concept upon which this fuse was developed consists of forced cooling of the fusible element by means of a high-speed coolant to greatly increase the fusing current and reduce the sectional area of the fuse. According to the results of studies of the minimum fusing current characteristics with various cooling methods using d.c. fuse testing facilities, it was demonstrated that when water is used as the coolant, the current flow capacity can be increased up to ten times (several kA's) that of conventional types. It was further shown in both a.c. and d.c. high-voltage (16 kV) power breaking tests that the satisfactory high-speed current limiting performance can be obtained.

(33) DIGESTS OF FUSE INFORMATION

(Since 1977: DIGESTS OF INFORMATION ON PROTECTIVE DEVICES).

Ed. by H.W. Turner and C. Turner.

Leatherhead, Surrey (England): Electrical Research Association, 1973-1979.

(b)

(34) Wieringa, L.

KORTSLUITSTROOMBEGRENZEND UITSCHAKELLEN, II (Short-Circuit Current Limiting Switching).

M.Sc. Thesis, Eindhoven University of Technology, Department of Electrical Engineering, Group Apparatus and Systems for Electrical Energy Supply, 1977. In Dutch.

(c)

(35) Bleys, C.A., D. Lebely, C. Rioux and F. Rioux-Damidau.

200 kA CIRCUIT BREAKER WITH 10 μ SEC CURRENT TRANSFER TIME. Rev. Sci. Instrum. 46 (1975) 11, p. 1542-1545.

A circuit breaker capable of transferring a 200 kA current to a fuse placed in parallel in 10 microseconds is described. The conducting element is a bar with a T-shaped cross-section, which is burst open at the joint of the arms and leg by pressurized insulating oil. The command, which uses magnetic pressure, is very efficient. The circuit breaker/fuse combination can be used to transfer energy stored in a coil driven by a homopolar generator rapidly to a load.

(36) Keders, T. and A.A. Leibold.

A CURRENT LIMITING DEVICE FOR SERVICE VOLTAGES UP TO 34.5 kV.

In: IEEE Power Engineering Society Summer Meeting, Portland, Or., 18-23 July 1976.

New York: Institute of Electrical and Electronics Engineers, 1976. Paper A76436-6, p. 1-7.

Construction and operation of the I_g -limiter are described extensively. Criteria for actuation are set up and possible fault simulation effects are studied. For this purpose a di/dt detector is chosen. Particular attention is given to the feeder of the actuation circuit. The 18-year experience is represented, emphasizing problems arising and the solutions found. Special attention is paid to the application of the I_g -limiter for utility and industrial power systems. Classification with regard to the place of the CLD in the total system and with regard to the problems occurring in the system gives information about the possibilities of the application of the I_g -limiter.

(37) Pflanz, H.M., T.F. Clark and O.J. Albani.

A NEW APPROACH TO HIGH-SPEED CURRENT LIMITATION.

In: Symposium Proc.: New Concepts in Fault Current Limiters and Power Circuit Breakers, Buffalo, N.Y., 28-30 Sept. 1976.

Palo Alto, Cal.: Electric Power Research Institute, 1977. EPRI EL-276-SR, p. 15/1-7.

Shortcomings of fuses as CLDs are mentioned. A new low-cost, high-speed CLD is described, which shows up hardly any losses during normal load operation. At the command of a fault sensor a linear charge divides the main con-

ductor into a multitude of pieces, among which arcs occur. The current commutates into a fuse. The time needed for commutation is appr. 0.2 ms.

- (38) Leroux, B. and F. Rioux-Damidau.

ÉTUDE DE DISJONCTEURS RAPIDES POUR COURANTS INTENSES
(Study of High-Speed Circuit Breakers for High Currents).
Rev. Phys. Appl. 14 (1979) 7, p. 705-713. In French.

Describes a switch which opens at the command of an electromagnetic signal. The current commutates into a fuse which subsequently explodes, thus definitely interrupting the current. Interrupted currents are of the order of 100 kA, commutation is achieved in a few microseconds.

Not consulted:

- (39) Ford, R.D. and I.M. Vitkovitsky.

EXPLOSIVELY ACTUATED 100 KA OPENING SWITCH FOR HIGH
VOLTAGE APPLICATIONS.

In: 1977 IEEE Int. Conf. on Plasma Science, Troy, N.Y.,
23-25 May 1977.

New York: Institute of Electrical and Electronics
Engineers, 1977. P. 175. Abstract only.

A single-shot modular opening switch capable of carrying currents up to 100 kA indefinitely and opening in a time of appr. 70 microseconds has been developed. Very low jitter characteristics of the switch trigger as well as its simplicity allow the switch to be used in series and in parallel operation. The switch operates on the principle of an explosively generated pressure which radially drives paraffin to produce multiple ruptures in a cylindrical conductor. Electric probes and fast frame photography are used to determine its mechanical performance characteristics. A 15-segment switch develops 8 kV in 10 to 20 microseconds (after trigger application) in the process of interrupting 100 kA when used as a safety interrupt device, or 25 kV at 100 kA when used with an integral exploding wire fuse for current transfer needed to extinguish the arc. Time dependent resistance of the arc and its restriking characteristics are discussed.

- (40) Datsenko, V.A., G.Ya. Shimkevich and V.L. Korol'kov.
 APPLICATION OF AN EXPLOSIVE SWITCH FOR CURRENT LIMITING.
 Prom. Energ. (1979) 7, p. 33-36. In Russian.

Describes a current limiter which consists of two parts: an explosion chamber, housing a current conducting strip with an electric detonator, and a special meltable fuse, connected in parallel with the destructible current conductor. Circuit details and the operation of the drive are explained. The performance specifications are as follows: rated voltage 0.1-6 kV; working current 400-1250 A; maximum level of switched overvoltages is not more than 1.5 p.u.; operating time is 60-80 μ s; the total switch-off time is 3-5 ms and the selectivity step of the actuation current is in the range of 200-300 A.

(d)

- (41) Dodds, T.H. and N.S. Rau.
 CURRENT COMMUTATION TO A RESISTOR AS A FAULT CURRENT LIMITER.

In: IEEE Power Engineering Society Winter Meeting, New York, N.Y., 25-30 Jan. 1976.

New York: Institute of Electrical and Electronics Engineers, 1976. Paper A76085-1, p. 1-7.

The principle of operation of a fuse-to-resistor commutation limiter is described. Parameters are introduced with which requirements and performance can be indicated. The operation is investigated by computer simulation and by laboratory and field tests.

- (42) Kroon, P.J. and W.N. Rothernbuhler.
 THE DEVELOPMENT AND APPLICATION OF A 69 KV FAULT CURRENT LIMITER.

In: 7th IEEE Power Engineering Society Transmission and Distribution Conf. and Exposition, Atlanta, Ga., 1-6 Apr. 1979.

New York: Institute of Electrical and Electronics Engineers, 1979. P. 237-244.

Applications and requirements for a CLD in a specific case are mentioned. A fuse-to-resistance commutation limiter is described and results of experiments are discussed.

IV. SUPERCONDUCTION

The sharp transition of a superconductor from its superconducting to its normal state when exceeding the critical current suggests its application as an automatic and - at least in principle - very reliable short-circuit current limiter. The development of a superconducting (SC) switch has received a strong impetus from the field of cryogenic power engineering, e.g. for energy storage in superconducting coils in behalf of fusion reactors, etc. The idea has also been adopted for application in utility networks.

The principle of operation of a superconducting current limiting device (SCCLD) is very simple. A superconductor in a cryostat is maintained at a temperature below the critical value. When a short circuit occurs, the SC is switched to its normal state either by thermal, magnetic or current triggering. Thus a series impedance is inserted into the circuit which limits the fault current.

In practice a multitude of problems arise which hinder application of the SCCLD in utility networks. One of the major problems is the occurrence of so-called hot spots, i.e. spots where the critical current density is exceeded, so that locally the SC is switched to its normal state while elsewhere superconduction is maintained; excessive heat production causes the conductor to melt, starting from the hot spot. Harrowell (43,44) suggests backing the SC over its entire length with a semiconductor which has a negative temperature coefficient in the relevant temperature range. At a local temperature rise the impedance of the semiconductor decreases by which the current is commutated locally from the SC to the semiconductor, and the SC is protected against melting. Thermal triggering can also cause hot spots when heating is not sufficiently homogeneous. Very homogeneous heating can be reached by imposing the SC to electron or X-ray radiation (46).

Rapid switching requires a low heat capacity; in order to achieve sufficiently high impedance in the normal state a very long and thin conductor must be used. These requirements make the SC element unfit to carry current for a long period of time. So a commutation element is needed with an impedance which is much lower than that of the SC in its normal state. This,

however, reduces the effective current limitation drastically (49,51).

It is possible to connect the SC with the main circuit via an inductive coupling. This can lead to a strongly simplified construction. Darton (52) uses an SC winding around a core to saturate it during normal operation and to get it out of saturation when a short circuit occurs. The primary winding around the core thus operates like a saturable self-inductance.

Calculations have been performed showing that SCCLDs become viable for application in utility networks for voltages above 550 kV (57). In view of the copious technical problems it should be seriously questioned if SC switches will be able to operate reliably at such extremely high voltages. Moreover, it is doubtful whether SC limiters can ever compete with alternative CLDs.

REFERENCES

- (43)
- Harrowell
- , R.V.

A NEW SUPERCONDUCTING SWITCH.

J. Phys. D. 7 (1974) 4, p. 491-494.

A new design SC switch is presented. The problem of hot spots is solved by backing the SC with a semiconductor with a negative temperature coefficient. Calculations of design parameters are given as well as requirements to be met by the CLD. Problems are brought forward which might hinder its application. No experimental results are presented.

- (44)
- Harrowell
- , R.V.

NEW SUPERCONDUCTING SWITCH: FIELD-CIRCUIT VERSION.

Proc. Inst. Elec. Eng. 122 (1975) 2, p. 191-192.

The design of (43) is modified to make it economically more attractive. Only a fundamental lay-out is given; experiments are not described.

- (45)
- Grawatsch
- , K., H.
- Köfler
- , P.
- Komarek
- , H.
- Kornmann
- and A.
- Ulbricht
- .

INVESTIGATIONS FOR THE DEVELOPMENT OF SUPERCONDUCTING POWER SWITCHES.

IEEE Trans. Magn. MAG-11 (1975), p. 586-589.

The behaviour of some SC materials is investigated for different modes of operation. The SC switch turns out feasible for use as a rectifier with a switching frequency of 50 Hz. The construction and operation of an SC energy storage system including an SC switch is described extensively. Switching times with and without load current have been investigated for various current pulse amplitudes.

- (46)
- Schmieder
- , R.W.

SUPERCONDUCTING SWITCHES USING RADIATION INDUCED QUENCHING.

IEEE Trans. Magn. MAG-11 (1975), p. 590-593.

The application of radiation for switching of an SC is investigated. The basic equations for the description of

this process are derived. The ratio of switched energy to switching energy is determined for a magnetic energy storage system. Pros and cons of electron and X-ray radiation are compared and weighed.

- (47) Gray, K.E., W.Y.K. Chen and R.P. Huebener.

EVALUATION OF SUPERCONDUCTORS FOR LARGE SCALE SWITCHING OF ELECTRICAL POWER.

IEEE Trans. Magn. MAG-13 (1977), p. 784-787.

Large-scale application of SC switches in energy supply systems is studied, including considerations on possibilities and efficiency. Some problems are dealt with extensively: the relatively small impedance in the normal state as well as specific problems with both magnetic and thermal switching. It is concluded that for most situations the SC switch is not feasible. The authors are hopeful about application of the SC in a CLD. This, however, turns out to become attractive only for voltages above 550 kV.

- (48) Gerlach, H. and K. Müller.

SUPRALEITENDE KURZSCHLIESSER UND STROMBEGRENZUNGSEINRICHTUNGEN (Superconducting Short-Circuiters and Current Limiters).

Elektrie 31 (1977), p. 606-610. In German.

The physical principle of the transition from the superconducting to the normal state is illustrated. After that the choice of the material, heating and heat transfer, switching properties and losses are dealt with. Resistive and inductive limitation are distinguished and compared for the SCCLD.

- (49) Gray, K.E., and D.E. Fowler.

SUPERCONDUCTING FAULT CURRENT LIMITER.

In: Symposium Proc.: New Concepts in Fault Current Limiters and Power Circuit Breakers, Buffalo, N.Y., 28-30 Sept. 1976.

Palo Alto, Cal.: Electric Power Research Institute, 1977. EPRI EL-276-SR, p. 12/1-9.

The principle of operation of a SCCLD with commutation

to a resistor is described. Switching is by means of magnetic pulses. A computer simulation illustrates the operation. A cost analysis is also given; for high voltages the cost becomes relatively low. Finally, pros and cons are summed up.

- (50) Glukhikh, V.A., A.I. Kostenko, N.A. Monoszon, V.A. Tishchenko and G.V. Trokhachev.

RESULTS OF INVESTIGATIONS OF HIGH SPECIFIC BREAKING POWER SUPERCONDUCTIVE DEVICES.

In: Proc. 7th Symposium on Engineering Problems of Fusion Research, Pt. I, Knoxville, Tn., 25-28 Oct. 1977.

New York: Institute of Electrical and Electronics Engineers, 1977. P. 912-915.

An SC switch is in course of development, containing no other element than the SC. Experimental results are given which illustrate the influence of various factors on the switching behaviour. The problems appear to hinder application in the near future. Investigations concentrate upon parallel switches.

- (51) Gray, K.E. and D.E. Fowler.

A SUPERCONDUCTING FAULT CURRENT LIMITER.

J. Appl. Phys. 49 (1978) 4, p. 2546-2550.

Covers the contents of (49) except for some details.

- (52) Darton, K.C.

A NEW POWER SYSTEM FAULT LIMITER.

Electr. Rev. 202 (1978) 5, p. 63-65.

An SC winding around the iron core of a self-inductance which is in series with the supply network, drives the core into saturation during normal load and gets it out of saturation when a fault occurs. The switching behaviour and the features of this CLD are described and many practicable applications are mentioned. The state of affairs in the development of this CLD is given in a few words. Results of experiments are lacking.

- (53) Ulbricht, A.

TEST RESULTS OF A RESISTIVE SC POWER SWITCH OF 40 MW SWITCHING POWER AT A VOLTAGE OF 47 kV.

IEEE Trans. Magn. MAG-15 (1979), p. 172-174.

Function and design of an SC circuit breaker are described. Further, test results are given. Developments necessary for a proper switching behaviour are derived. Some unexpected results concerning stability and propagation of a normal-conducting zone are indicated and an attempt is made to explain them.

- (54) Gray, K.E., T. Lenihan and J. Tarczon.

THIN FILM SUPERCONDUCTING SWITCHES.

IEEE Trans. Magn. MAG-15 (1979), p. 175-177.

This paper reports on preliminary results of experiments with thin film SC switches triggered by fast magnetic pulses. Pros and cons of using thin films are mentioned. Experiments are described and the results are discussed. It appears possible to switch very rapidly (in a few microseconds) with relatively low magnetic fields.

Not consulted:

- (55) Grawatsch, K.

FUNDAMENTAL INVESTIGATIONS ON THE FEASIBILITY OF SUPERCONDUCTING SWITCHING IN CRYOGENIC POWER ENGINEERING.

Report JUL-1132-SE, Kernforschungsanlage Jülich, 1974.

In German.

The topics covered in the investigation reported upon include the following: energy decoupling with SC switching and energy storages; the physics of the switching process; NbTi multicore conductors in a CuNi matrix (experimental); magnetic pulse circuit breaking; behaviour of multicore SCs in pulsed and a.c. switching conditions; measurements with NbN SC layers; comparison of the various SC materials.

- (56) Blevins, D.J. and J.D.G. Lindsay.

DESIGN AND PERFORMANCE OF TWO 10 KA SUPERCONDUCTING SWITCHES.

In: 2nd Int. Conf. on Plasma Science, Ann Arbor, Mich., 14-16 May 1975.

New York: Institute of Electrical and Electronics Engineers, 1975. P. 28. Abstract only.

Two SC switches of different physical design have been built and tested for use in transferring energy from an SC magnetic energy storage coil. Each switch can carry 10 kA while in the SC state. Switching is by driving the switches to their normal resistive state by current pulsing above their critical current limits. The resistance of the switches in their normal state is 4 Ohms. Both switches are made up of several small elements connected in parallel. Constructional details, methods of fabrication, methods of operation and test results are described.

- (57) AN EXAMINATION OF THE FAULT CURRENT LIMITER CONCEPT USING THE PRINCIPLE OF SUPERCONDUCTIVITY.

Final Report, EPRI RP-281-0.

Palo Alto, Cal.: Electric Power Research Institute.

- (58) Shell', A.R.

CURRENT LIMITING EQUIPMENT EMPLOYING THE PHASE TRANSITIONS IN METALS AND SUPERCONDUCTORS.

Izv. VUZ Energ. (1979) 2, p. 3-8. In Russian.

The phase transitions in metals and SCs can be used to create rapid-response, current limiting systems that are competitive with more conventional schemes in 500-1150 kV networks, where the fault levels can be in excess of 120 kA. For example, the device within which these transitions take place could be connected in the secondary circuit of a current limiting transreactor. The author studies the implications and some of the problems involved in realizing such a scheme.

V. TEMPERATURE DEPENDENT LIMITERS

Just like the transition of a SC from its SC state to its normal state implies the possibility of automatic current limitation, so does the change in resistance of a conductor as a function of the temperature, provided the temperature coefficient is positive and sufficiently large. Similar problems as those with SCCLDs occur here as well. Rapid transition from low to high impedance demands very low heat capacity. To be sure that load current can pass without hindrance during normal operation, a parallel element is needed to carry the current during normal operation and to commutate the current to the temperature dependent resistor in case of a short-circuit. To protect the resistor against melting and to dissipate the energy stored in the circuit another parallel resistor is needed with a high heat capacity.

Following these considerations Premerlani (59) arrived at the construction pictured in figure V-1. For proper functioning it is required that $R_2(\text{cold}) \ll R_1 \ll R_2(\text{hot})$. After extensive analysis the shortcomings of this principle turned out to hinder application of this CLD.

Gilmour and Marshall (60,61) found that certain metals (esp. tungsten), when immersed in liquid nitrogen, formed a gaseous jacket of nitrogen around them and could be heated electrically to any temperature up to their melting-point without oxidation. Thus it was possible for a change of resistivity of a factor 90 to be reached in that temperature range. For application in a.c. CLDs this transition turned out to be too slow.

Although the last word has not yet been said about this principle, it is not likely that it will occupy an important place among CLDs, because too many good alternatives are present.

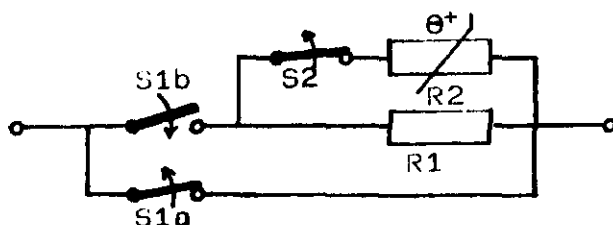

Figure V-1. CLD with temperature dependent resistor.

REFERENCES

- (59) Premerlani, W.J.
 A HIGH VOLTAGE CURRENT LIMITING DEVICE UTILIZING TEMPERATURE SENSITIVE RESISTORS.
 Doctoral Thesis, Rensselaer Polytechnic Institute, Troy, N.Y., 1975.
 University Microfilms Order no. 75-25,894.
 Describes a CLD with a temperature dependent resistor. Requirements for the CLD are listed and for a given design, initial conditions and fault magnitude, the thermal and electrical stresses in the CLD are determined. Theoretical and computer analysis show in detail the behaviour of the CLD as well as the sensitivity of the stresses mentioned for changes in design parameters. Time delay limits the performance of the limiter to 0.7 p.u. for a worst-case symmetrical fault. Additional problems are raised by the extremely strong electric field in the resistor. It is concluded that in its present form the CLD is not feasible, that the operation should be improved and time delays should be limited.
- (60) Gilmour, A.S. and J.D. Marshall.
 LIQUID NITROGEN COOLED WIRES AS SWITCHABLE HIGH-POWER DIRECT CURRENT LIMITING ELEMENTS.
 In: 1st IEEE Int. Pulsed Power Conf., Lubbock, Tex., 9-11 Nov. 1976.
 New York: Institute of Electrical and Electronics Engineers, 1976. P. 1C3/1-4.
 The so-called vapour lock effect is described; some metals when immersed in liquid nitrogen show no oxidation when heated up to their melting-point; this leads to a large change in resistivity for this temperature range. Results of experiments are discussed and an application is presented which can lead to still larger changes in resistivity.
- (61) Gilmour, A.S. and J.D. Marshall.
 LN₂-COOLED REFRACTORY METAL ELEMENTS AS CURRENT LIMITERS.
 Rev. Sci. Instrum. 48 (1977) 4, p. 460-461.
 Describes the same phenomenon as (60).

VI. CURRENT INJECTION

The major problem of switching off direct current is the lack of a natural current zero. To avoid this problem an artificial current zero can be forced by injecting a reverse current into the switch.

When a short-circuit alternating current is to be limited effectively, measures have to be taken long before first natural current zero. It is obvious that here current injection (CI) may similarly give a solution.

Papadias ⁽⁶²⁻⁶⁴⁾ applies the CI technique for HVAC limitation. He uses a precharged capacitor (see figure VI-1) which is discharged at the occurrence of a short circuit, thus injecting a reverse current through the interrupter, which finally commutates the current into an RC network. The saturable reactor L_1 is in series connected with the main circuit even during normal operation and thus leads to continuous power and voltage losses. Since a.c. fault current can be positively or negatively directed during the first half cycle, the possibility of bidirectional current injection is desirable.

Damsky et al. ⁽⁶⁶⁾ use a slightly different circuit (see figure VI-2). Since modern vacuum interrupters are capable of interrupting currents at high di/dt , the series inductance is no longer needed. The nonlinear resistance functions as a surge arrester. The vacuum interrupter and its influence on the circuitry have been extensively described by Anderson and Carroll ⁽⁶⁵⁾; they showed that the saturable reactor is not essential for reliable interruption.

The CI technique offers good prospectives, not in the least by the excellent performance of modern vacuum interrupters. It may only be wondered if the complexity of the circuit does not form a hindrance to large-scale application.

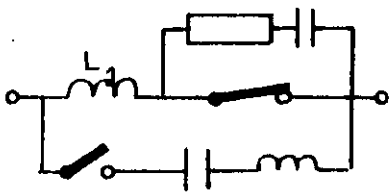

Figure VI-1. CI circuit

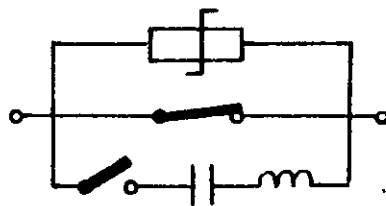

Figure VI-2. CI circuit

REFERENCES

(62) Papadias, B.C.

APPROACHES TO SHORT-CIRCUIT CURRENT LIMITING.

Doctoral Thesis, Rensselaer Polytechnic Institute, Troy, N.Y., 1975.

University Microfilms Order no. 75-25,878.

A short survey of existing limiting principles is given. The CI method is introduced as a new HVAC limiting principle. All principles mentioned are evaluated. A disadvantage of the CI method is the saturable reactor which is continuously series connected with the main circuit. As main switch a vacuum interrupter is used. All components are described in detail. Experiments illustrate the operation of the CLD. A solution is searched for the problems arisen.

(63) Papadias, B.C.

USE OF THE CURRENT INJECTION TECHNIQUE AS A CURRENT LIMITING MEANS IN AC POWER SYSTEMS.

In: IEEE Power Engineering Society Summer Meeting, Mexico City, Mex., 17-22 July 1977.

New York: Institute of Electrical and Electronics Engineers, 1977. Paper A77715-6, p. 1-6.

Describes circuitry and operation of the CI method. Experiments are described, followed by a discussion of the results, esp. concerning the interruption probability as a function of di/dt and du/dt . These turn out to be dependent on parameters of the saturable reactor (magnetic flux and air gap) and the load voltage of the precharged capacitor. The main switch is a vacuum interrupter. In the appendix the design parameters of the reactor are treated.

(64) Papadias, B.C.

APPLICATION OF THE CURRENT INJECTION LINK AS A FAULT CURRENT LIMITING MEANS.

In: IEEE Power Engineering Society Summer Meeting, Los Angeles, Cal., 16-21 July 1978.

New York: Institute of Electrical and Electronics Engineers, 1978. Paper A78506-8, p. 1-5.

Describes possibilities, requirements and problems concerning CI. It is stated that the injected current must be able to flow in either direction. As a solution the use of two parallel capacitors with opposite polarity, both in series with a trigatron, is proposed. A fast vacuum interrupter is needed for proper limitation. Two modes of operation are mentioned: switching at a certain value of the fault current or after a certain duration of the fault current. The former appears to be the most advantageous and reliable. Suitable control circuitry, an ultrafast opening mechanism and economically attractive alternatives for bipolar CI should be found. The appendix gives a practicable limiter circuit and a short cost analysis.

- (65) Anderson, J.M. and J.J. Carroll.

APPLICABILITY OF A VACUUM INTERRUPTER AS THE BASIC SWITCH ELEMENT IN HVDC BREAKERS.

IEEE Trans. Power Appar. & Syst. PAS-97 (1978) 5, p. 1893-1900.

The applicability of a vacuum interrupter in the CI circuit for HVDC limitation is analyzed. Test procedure and results are discussed extensively for both a saturable and a linear reactor in series with the switch. Although the vacuum switch is unipolar, one interrupter is sufficient also for HVAC limitation. Success and failure in interruption are analyzed statistically.

- (66) Damsky, B.L., P. Barkan, I. Imam and W. Premerlani.

A NEW HVDC CIRCUIT BREAKER SYSTEM DESIGN FOR \pm 400 kV.

In: 7th IEEE Power Engineering Society Transmission and Distribution Conf. and Exposition, Atlanta, Ga., 1-6 Apr. 1979.

New York: Institute of Electrical and Electronics Engineers, 1979. P. 230-236.

A new CI circuit is introduced. Purpose of the research program and requirements for the limiter concerning speed and energy dissipation are laid down. These and other specifications are used as a basis for the design. Immersion of the circuit in an SF₆-filled tank is proposed.

VII. VACUUM AND GAS DISCHARGE TUBES.

The first impulses for the application of vacuum and gas discharge tubes as current interrupters at high voltages were given by the problems arising at the interruption of high-voltage direct current - as was the case for the CI principle. The tubes are capable of interrupting high currents very rapidly at high voltages by triggering with a magnetic field. Although vacuum interrupters and gas discharge tubes have much in common they will be dealt with separately in the following.

A. Vacuum Interrupters

In principle two kinds of vacuum interrupters (VI) can be distinguished, characterized by axial and transversal geometry respectively. The relevant processes for interruption are essentially different for the two kinds (71). In either case interruption is achieved by applying a magnetic field. This field influences the arc voltage between the electrodes via the Hall effect.

The configuration of the VI with axial geometry is given in figure VII-1. Its operation is described by various authors (67-69,72,73). When no axial magnetic field is present a low-voltage arc is maintained between cathode and anode. This arc is initiated by a third electrode, the so-called igniter, which is separated from the cathode by an insulator on which the metallic vapour from the arc can precipitate, forming a thin conductive film. To ignite the arc a current pulse is passed through the film causing a portion of it to vaporize. The resulting plasma burst quickly fills the inter-electrode space, allowing the main current to pass. When a magnetic field is applied the arc voltage increases greatly due to the Hall effect. This causes limitation and possibly interruption of the passing current.

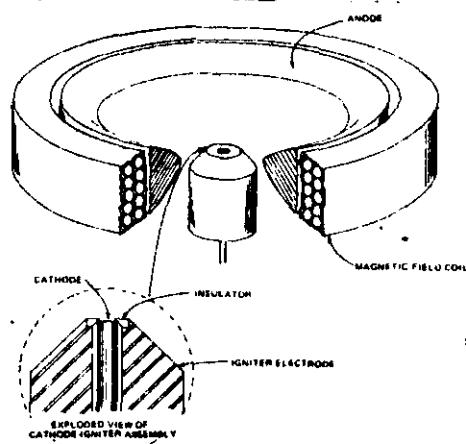

Figure VII-1. Configuration of HV arc interrupter. From Gilmour and Lockwood (67)

The energy involved in this process is to be dissipated by the anode; therefore high demands are made on the size and material of the anode. Investigations aim at improving the interrupting capacity, the anode properties and the lifetime of the VI. The present interrupting capacity is appr. 50 MW but an increase towards 1 GW and more is expected. Lifetime can be increased by choosing more adequate materials. A mechanical switch in parallel to carry normal load current and a resistor in parallel to dissipate the energy involved lead to a much longer lifetime and to a higher interrupting capacity.

The VI with transversal geometry has received only little attention in recent years' literature ^(70,71). It consists of two similar electrodes in vacuum, one of which is stationary and the other moveable. During normal operation the electrodes are pressed together and the tube behaves like an ordinary closed switch. If a fault occurs the moveable electrode is torn away from the other very rapidly; thus an arc is initiated, the voltage of which can be greatly increased by a magnetic field. A resistor is needed in parallel, to which the current can commute. Currents of 8.5 kA are thus commutated at 40 kV. Here too, the investigations aim at increasing the interrupting capacity.

When comparing both kinds of VIs some important differences are found:

- The VI with transversal geometry is not able to interrupt the current definitely in a very short time and to dissipate the involved energy. Therefore a commutation resistor is indispensable.
- The axial VI needs a separate in-line switch; this may raise economic objections.
- The axial VI is unipolar; therefore an a.c. limiter will need two interrupters with opposite polarity in parallel.

B. Gas Discharge Tubes

The pressure in gas discharge tubes exceeds that in VIs by a few orders of magnitude. This causes the magnetic field to have an effect opposite to that in VIs. It stimulates ionization of the plasma (Penning effect), so that the tube conducts with and interrupts without magnetic field. This tube

is known as Crossed-Field Switch Tube (XFST). It exists both as a unipolar and as a bipolar device.

In recent years its application as a CLD has concentrated upon a circuit named Switched Resistor Fault Current Limiter (SRFCL).

C. Switched Resistor Fault Current Limiter

The principle of operation of this limiter is immediately implied by the features of vacuum and gas discharge tubes. The circuit is pictured in figure VII-2. During normal operation S carries the load current. In case of a fault, S opens and the interrupter I - switched to its conductive state - takes over the current. When the moving contacts of S are sufficiently far apart, I interrupts the current, thereby commutating it to R and C, and R dissipates the energy involved. R is a nonlinear resistor with a characteristic $V=CI^{1/4}$; the nonlinear character of R limits overvoltages. The operation of the fault sensor FS has been described in detail by Lee et al. (14).

The degree of limitation greatly depends on the speed of the circuit, especially that of S. Therefore the development of a fast mechanical switch is one of the most important objects of investigation.

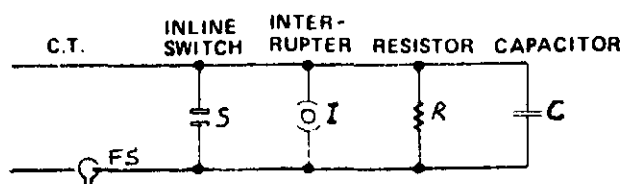

Figure VII-2. Switched Resistor Fault Current Limiter.
From Lee et al. (14).

REFERENCES

A. Vacuum Interrupters

- (67)
- Gilmour
- , A.S. and D.L.
- Lockwood
- .

THE INTERRUPTION OF VACUUM ARCS AT HIGH DC VOLTAGES.
IEEE Trans. Electr. Dev. ED-22 (1975) 4, p. 173-180.

A basic description is given of the configuration of the VI and its operation. It is proved that arc interruption is established by switching a magnetic field. Arc interruption is studied at 3, 15 and 25 kV. The turn-off characteristics are analyzed. Next an attempt is made to determine the lifetime of the VI. The VI can interrupt 800 A at a circuit voltage of 25 kV.

- (68)
- Gilmour
- , A.S.

THE PRESENT STATUS AND PROJECTED CAPABILITIES OF VACUUM ARC OPENING SWITCHES.

In: 1st Int. Pulsed Power Conf., Lubbock, Tex., 9-11 Nov. 1976.

New York: Institute of Electrical and Electronics Engineers, 1976. P. 1C1/1-4.

A description of the VI is given. The state of affairs in its development is indicated, esp. concerning its performance. Currents of 4 kA can be interrupted in ca. 2 μ s at 25 kV. Regions and directions where more research is needed are mentioned. This research is expected to lead to an interrupting capacity of 10-50 kA at 100 kV in less than 1 μ s.

- (69)
- Gilmour
- , A.S.

FEASIBILITY OF A VACUUM ARC FAULT CURRENT LIMITER.

In: Symposium Proc.: New Concepts in Fault Current Limiters and Power Circuit Breakers, Buffalo, N.Y., 28-30 Sept. 1976.

Palo Alto, Cal.: Electric Power Research Institute, 1977. EPRI EL-276-SR, p. 17/1-19.

A basic description of the VI is given. Research proceeds in two phases; (a) Investigation of the applicability and verification of the current limiting capacity; the VI must be able to limit currents of over 100 kA prospective and

at the same time it must dissipate the energy stored in the circuit. (b) Development of design criteria by theoretical and experimental analysis. The state of affairs and the problems arising in both research phases are indicated, as well as prospectives for further investigations.

- (70) Kimblin, C.W., P.G. Slade, J.G. Gorman, F.A. Holmes, P.R. Emtage, R.E. Voshall and J.V.R. Heberlein.

DEVELOPMENTAL STUDIES OF A CURRENT LIMITER USING VACUUM ARC CURRENT COMMUTATION.

In: Symposium Proc.: New Concepts in Fault Current Limiters and Power Circuit Breakers, Buffalo, N.Y., 28-30 Sept. 1976.

Palo Alto, Cal.: Electric Power Research Institute, 1977. EPRI EL-276-SR, p. 18/1-50.

Investigations into the use of forced instability of vacuum arcs to insert an impedance into the line during the fault current rise are reported. The present feasibility studies have concentrated on evaluating the use of transverse magnetic fields to force current commutation. Arcs have been established between separating electrodes in vacuum, and the factors affecting subsequent arc current commutation into a parallel resistor and a parallel capacitor have been investigated at current levels up to 10 kA. Commutation ability has been studied as a function of the magnitude of the applied transverse magnetic field, the magnitude of the capacitance and resistance in parallel and the electrode spacing. The interaction of vacuum arcs with applied transverse magnetic fields has been established experimentally and theoretically.

- (71) Kimblin, C.W., P.G. Slade, J.G. Gorman, F.A. Holmes, P.R. Emtage, R.E. Voshall and J.V.R. Heberlein.

DEVELOPMENT OF A CURRENT LIMITER USING VACUUM ARC CURRENT COMMUTATION: PHASE 1: A FEASIBILITY STUDY FOR USING ARC INSTABILITY IN VACUUM FOR CURRENT LIMITATION.

Final Report of EPRI Research Project 564-1, March 1977. Palo Alto, Cal.: Electric Power Research Institute, 1977. EPRI EL-393.

The main part of this paper covers the contents of (70).

Further recommendations are made for further research. Appendices deal with: (a) A comparison of axial and transversal geometry. (b) Parameter variation to optimize amplitude, uniformity and risetime of the magnetic field. (c) The development of a mechanism for rapid separation of the contacts of the VI. (d) Attempts to shield off the envelope of the interrupter. (e) An analysis of a circuit mentioned earlier in this paper.

- (72) Bowman, C.D., A.S. Gilmour, R. Dollinger and D.P. Malone. ENERGY CONSIDERATIONS IN THE PULSED OPERATION OF A VACUUM ARC CURRENT LIMITER.

In: IEEE 1978 13th Pulsed Power Modulator Symposium, Buffalo, N.Y., 20-22 June 1978.

New York: Institute of Electrical and Electronics Engineers, 1978. P. 213-216.

Gives a basic description of the vacuum arc current limiter (VACL). For a.c. applications two parallel VACLs in opposite direction are needed, because of the unipolarity of the device. Equations are derived for short-circuit currents with and without VACL. Heat transfer, power density and temperature distribution in the anode are determined. From these data requirements can be derived concerning anode design. A large surface is needed to prevent the anode material from melting. Alternatives are proposed, like different shapes and materials for the anode and parallel switching of a commutation resistor.

- (73) Bowman, C.D., R. Dollinger, A.S. Gilmour and D.P. Malone. AN ANALYSIS OF A VACUUM ARC FAULT CURRENT LIMITER FOR USE IN POWER SYSTEMS.

In: IEEE Power Engineering Society Winter Meeting, New York, N.Y., 4-9 Febr. 1979.

New York: Institute of Electrical and Electronics Engineers, 1979. Paper A79093-6, p. 1-7.

A short survey is given of the main features of vacuum arcs. Two VACLs are described, with and without magnetic field. A fault current analysis is made for the former: the peak current appears to be limited from 42 kA (prospective current) to 11 kA at 38 kV. Next the heat transfer is studied. From the result the anode design is con-

sidered. Possibilities of commutation to a parallel resistor are mentioned.

Not consulted:

- (74) Kimblin, C.W., P.G. Slade, R.E. Voshall, F.A. Holmes,
J.G. Gorman and P.R. Emtage.

CURRENT COMMUTATION USING MAGNETIC FIELDS TO FORCE INSTABILITY OF VACUUM ARCS.

In: 1976 IEEE Int. Conf. on Plasma Science, Austin, Tex., 24-26 May 1976.

New York: Institute of Electrical and Electronics Engineers, 1976. P. 145. Abstract only.

Arcs have been established between separating electrodes in vacuum, and the factors affecting subsequent arc current commutation into a parallel resistor and capacitor have been investigated at current levels up to 10 kA. The experiments were performed at low d.c. circuit voltages (80 V) in a demountable arc chamber, and in a.c. circuits at voltages of 10 kA and above. The probability of successful current commutation increases with increasing magnetic field and increasing electrode spacing, and also with increasing capacitance with consequent enhanced arc instability and reduction of the rate of rise of circuit recovery voltage. The interaction of vacuum arcs with applied transverse magnetic fields has been determined experimentally and theoretically. It is shown that field application causes formation of a single arc column which bends away from the anode. This bending is due to magnetically induced Hall fields within the plasma which influence the trajectory of the metal-ions emitted from the cathode spots.

- (75) Gilmour, A.S.

CIRCUIT INTERRUPTION USING A VACUUM ARC SWITCH.

In: 1976 IEEE Int. Conf. on Plasma Science, Austin, Tex., 24-26 May 1976.

New York: Institute of Electrical and Electronics Engineers, 1976. P. 169. Abstract only.

A simple light-weight device capable of interrupting 800 A at 25 kV is described. Operation at higher levels

was limited, not by the interrupter, but by lack of adequate power supplies. The device has been operated at repetition rates of several pulses per second. Recent results at current levels above 800 A and at pulse lengths in the 0.5-40 ms range will be described. Possible applications to inductive energy storage systems are discussed.

B. Gas Discharge Tubes

- (76) Gallagher, H.E., G.A. Hofmann and M.A. Lutz.

THE CROSSED-FIELD SWITCH TUBE - A NEW HVDC CIRCUIT INTERRUPTER.

IEEE Trans. Power App. & Syst. PAS-92 (1973), p. 702-709.

A crossed-field (Penning) discharge device has been developed which can perform HVDC interruption. The discharge is controlled by a magnetic field, the removal of which causes the plasma to decay in ca. 0.01 ms. The present single tube capability is 100 kV/2000 A with a recovery rate of 2 kV/ μ s. The tubes are capable of series and parallel operation.

- (77) Lutz, M.A. and G.A. Hofmann.

THE GAMITRON: A HIGH POWER CROSSED-FIELD SWITCH TUBE FOR HVDC INTERRUPTION.

IEEE Trans. on Plasma Science PS-2 (1974) 1, p. 11-24.

The principle of operation of an XFST is described. The breakdown phenomena which determine the interrupting capacity and the time delays in the ignition are discussed. Experiments are described which illustrate the discharge properties; attention is paid to the interaction between the discharge and the electrode surface and to transient effects in an XFST. As for high-voltage current interruption magnetic triggering, the plasma decay time and the rrrv are treated. Several applications are indicated. The XFST interrupts 2 kA at 100 kV with an rrrv of 2 kV/ μ s.

- (78) Harvey, R.J. and M.A. Lutz.

HIGH POWER ON-OFF SWITCHING WITH CROSSED-FIELD TUBES.

IEEE Trans. on Plasma Science PS-4 (1976) 4, p. 210-217.

The XFST is described and requirements for good switching behaviour are determined. Experiments are described and

the phenomena and problems which appear from those are thoroughly analyzed.

- (79) Harvey, R.J., M.A. Lutz and H.E. Gallagher.

CURRENT INTERRUPTION AT POWERS UP TO 1 GW WITH CROSSED-FIELD TUBES.

IEEE Trans. on Plasma Science PS-6 (1978) 3, p. 248-255.

The principle of operation of an XFST is indicated. Experiments are described with 3 different XFSTs. The results are discussed and compared. It appears possible to interrupt 10 kA at 100 kV.

C. Switched Resistor Fault Current Limiter.

- (80) Long, W.F. and K.T. Lian.

A DESIGN STUDY FOR A DC CIRCUIT BREAKER ON A THREE-TERMINAL HVDC SYSTEM.

In: IEEE Power Engineering Society Winter Meeting, New York, N.Y., 27 Jan.-1 Febr. 1974.

New York: Institute of Electrical and Electronics Engineers, 1974. Paper C74131-9.

The system is described and the interrupter design given. The operation of the individual components is discussed. The parameters and the mode of operation are determined with a digital computer.

- (81) Knauer, W.

A RESISTOR SWITCHING CURRENT LIMITING DEVICE WITH MILLI-SECOND RESPONSE TIME.

In: Symposium on Current Limiting Devices - IEEE Power Engineering Society Summer Meeting, Anaheim, Cal., 14-19 July 1974.

New York: Institute of Electrical and Electronics Engineers, 1975. Order no. 75CH01037-1-PWR, p. 22-26.

The entire system is described as well as the individual components of the SRFCL. Estimated switching time and interrupted current are determined.

- (82) Hofmann, G.A., G.L. LaBarbera, N.E. Reed and L.A. Shillong.

A HIGH SPEED HVDC CIRCUIT BREAKER WITH CROSSED-FIELD INTERRUPTERS.

IEEE Trans. Power App. & Syst. PAS-95 (1976), p. 1182-1193.

Requirements to be met by an HVDC interrupter are derived. The SRFCL and its components are described. Attention is paid to the way of fault detection and the control mechanism. Tests are described and discussed and results are given.

- (83) Hofmann, G.A., G.L. LaBarbera, N.E. Reed and L.A. Shillong.
A HIGH SPEED HVDC CIRCUIT BREAKER WITH CROSSED-FIELD INTERRUPTERS AND ITS FIELD TEST ON THE PACIFIC INTERTIE SYSTEM.

In: 1976 IEEE Region 6 Conf. on Energy for the Future, Tucson, Ariz., 7-9 Apr. 1976.

New York: Institute of Electrical and Electronics Engineers, 1976. P. 188-195.

The interrupter is described; next the configuration of the Pacific Intertie is given and the tests which are performed there are described. The results are given and discussed.

- (84) Knauer, W.

PROGRESS REPORT ON A SWITCHED RESISTOR FAULT CURRENT LIMITER.

In: Symposium Proc.: New Concepts in Fault Current Limiters and Power Circuit Breakers, Buffalo, N.Y., 28-30 Sept. 1976.

Palo Alto, Cal.: Electric Power Research Institute, 1977. EPRI EL-276-SR, p. 16/1-15.

Gives a short description of the SRFCL, its operation, its speed and its components. A fault sensor compares the rate of rise of the fault current with that of a simulator and decides within 0.5 ms. For the in-line switch a new model is used with rotating contacts and a high-pressure gas tank serves to increase the arc voltage rapidly. For the interrupter an XFST is used. A nonlinear resistor is used for current commutation. A lay-out of a complete 1-phase SRFCL module is given.

- (85) King, H.J. and W. Knauer.

A CURRENT LIMITING DEVICE UTILIZING A SWITCHED RESISTOR.

In: 1977 Control of Power Systems Conf. and Exposition, College Station, Tex., 14-16 March 1977.

New York: Institute of Electrical and Electronics Engineers, 1977. P. 10-13.

The place of a CLD in a distribution system is discussed. Design criteria for a CLD are determined. Next the SRFCL is introduced and some special properties are mentioned.

(86) Grzan, J., J.E. Beehler, W. Knauer and H. King.

APPLICATION AND DEVELOPMENT OF A FAULT CURRENT LIMITING DEVICE.

In: Proc. 27th Session Int. Conf. on Large High Voltage Electric Systems (CIGRE), Paris, 30 Aug.-7 Sept. 1978. Vol. 1.

Paris: International Conference on Large High Voltage Electric Systems, 1978. Paper 23-05, p. 1-11.

Describes the need of a CLD in the nearby future. Possibilities and possible demands for a CLD are summed up. The design of a SRFCL is given and its components are described in detail. Experiments and relevant results are given.

VIII. SERIES INDUCTANCE

A. Limiting Coil

The principle of the so-called Limiting Coil - an ordinary series self-inductance - is quite old. The major disadvantage of this principle is that proper current limitation is necessarily accompanied by a considerable voltage drop across the self-inductance during normal operation. For circuits with extreme short-circuit currents this compromise is unacceptable. Only in situations where moderate current limitation is sufficient, owing to its simplicity, reliability and low cost, the limiting coil can be applied in an economically attractive way. However, since demands regarding the degree of current limitation will become more and more strict, it is to be expected that the role of the limiting coil in the future will be restricted.

B. Current Limiting Conductor

The use of a series self-inductance can offer new perspectives, if one succeeds in making its value variable. In this way a low inductance for normal operation could be combined with a high inductance for a short-circuit. The so-called Current Limiting Conductor (CLC) operates on this principle.

A possible lay-out for the CLC is given in figure VIII-1. During normal operation the two parts of the framework are separated, which results in low inductance. When the current

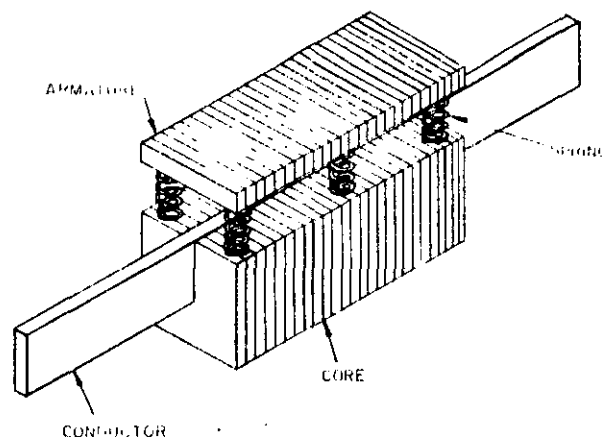

Figure VIII-1. Current Limiting Conductor. From Pflanz et al.⁽⁹⁰⁾

exceeds a critical value the magnetic forces between the two parts become so strong that they move towards each other against the pressure of the springs, thus increasing the inductance.

The disadvantages of the CLC are its inertia and the possible saturation of the framework. The former effect limits proper operation during first cycle fault current, whereas the latter effect deteriorates the limitation effect continuously, because it decreases the inductance. Here as well as for the Limiting Coil the advantages of simplicity, reliability and low cost may in many cases predominate so that it may be expected that in the years to come the CLC will be economically attractive for numerous applications.

REFERENCES

A. Limiting Coil

- (87) Gampenrieder, R., D. Steinwender and K. Papp.

DER EINSATZ VON KURZSCHLUSSBEGRENZUNGSDROSSELN IN 110 kV-NETZEN (Application of Short-Circuit Limiting Coils in 110 kV Networks).

Elektrizitätswirtschaft 74 (1975) 20, p. 732-735. In German.

Measures that can be taken to limit short-circuit currents are mentioned. The possible application of Limiting Coils in 110 kV networks is discussed. On the basis of system data its dimensions are determined. Construction and layout of the coils are discussed, as well as measures for the control of voltage and current requirements. Experiments are described in brief. Next the system is adapted in order to limit overvoltages, to relieve circuit breakers and limit power and voltage losses in the coils. In the situation described in this paper, these are 5 kV and 0.08% respectively.

Not consulted:

- (88) Kuchumov, L.A. and N.I. Utegulov.

USE OF DOUBLE REACTORS WITH CURRENT LIMITERS IN DISTRIBUTION NETWORKS.

Elektrichestvo (1976) 12, p. 8-13. In Russian.

The authors propose variants of reactor circuitry for achieving higher voltage quality with the short-circuit currents in 6-10 kV distribution networks. The main variants consist of current limiters used in conjunction with a doubled reactor or reactor-transformer. The possible use of switchgear with relatively low rupturing capacity is suggested.

- (89) Neklepaev, B.N. and S.V. Efimov.

AN EXPERIMENTAL INVESTIGATION OF A CURRENT LIMITING CONTROLLED REACTOR.

Izv. VUZ Energ. (1978) 11, p. 117-119. In Russian.

Describes a controlled current limiting reactor consisting of two closed cores with one main winding each and a magnetizing winding which is common to both cores, ener-

gized via a rectifier from an a.c. supply that is independent of the protected circuit. Presents oscillograms illustrating tests carried out.

B. Current Limiting Conductor

(90) Pflanz, H.M., T.F. Clark and O.J. Albani.

THE CURRENT LIMITING CONDUCTOR.

In: Symposium Proc.: New Concepts in Fault Current Limiters and Power Circuit Breakers, Buffalo, N.Y., 28-30 Sept. 1976.

Palo Alto, Cal.: Electric Power Research Institute, 1977. EPRI EL-276-SR, p. 14/1-20.

Construction and principle of operation of the CLC are described. The following topics are discussed: magnetic properties, optimal use of copper and steel, the armature movement, the electric circuit, theory of the interaction between CLC and network, experiments, losses, speed, noise, reliability, operation features. The closing of the armature takes 3-4 ms; at a prospective fault current of 45 kA rms the first peak is limited to 49 kA and the following peaks to 5 kA.

Not consulted:

(91) DEVELOPMENT OF THE CURRENT LIMITING CONDUCTOR.

Final Technical Report of EPRI Project RP 324-1, prepared by Phoenix Electric Corp. EPRI EL-286.

Palo Alto, Cal.: Electric Power Research Institute, 1977.

IX. RESONANCE LINKS

For the limitation of short-circuit currents resonance links can be utilized. Two principles can be distinguished (see figure IX-1):

First a series resonance link which is tuned to the network frequency during normal operation can be brought out of tune either by varying the self-inductance (a) or by shunting the capacitor (b). Further two series resonance links in parallel can be switched to two parallel resonance links in series (c).

Although the two principles mentioned are both based on the resonance principle, they differ so essentially that we prefer to discuss them separately.

A. Limiter Coupling

In order to bring a series resonance link out of tune one must vary either the self-inductance or the capacitance. Several possibilities present themselves:

1. A saturable inductance is used. For rated current the coil is unsaturated and the link is tuned to the network frequency. When the current exceeds a certain value the coil goes into saturation; its reactance decreases and the link gets out of tune. The voltage drop across it increases greatly and thus the current is limited.
2. The capacitive part of the link is varied by shunting the capacitor with a nonlinear network; this may be a switch or a spark gap or even a saturable reactor. When exceeding the critical value the current is limited by the voltage drop produced by a change in the effective impedance of the link.

The literature produced in recent years mainly concentrates on a circuit which is pictured in figure IX-2. During

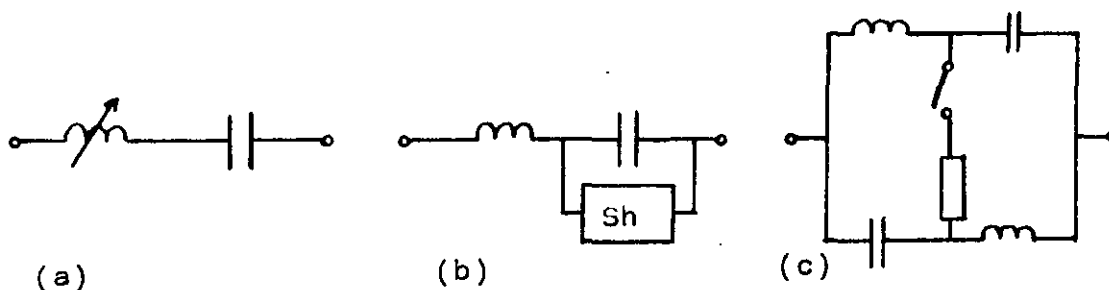

Figure IX-1. Various resonance links.

normal operation the impedance of S is so high that its influence can be neglected. When S goes into saturation its impedance greatly decreases and the link gets out of tune. A resistor can be connected in series with S to damp currents flowing through the parallel network SC and to damp peak currents which may occur at the transition between saturated and unsaturated mode.

Pros and cons of this Limiter Coupling have been collected and discussed by Lawrenz et al. ⁽⁹²⁾. As major advantages they mention its inertialess operation and the wide choice of the degrees of limitation. The major disadvantages are considerable losses, relatively high cost and large dimensions.

Thanawala ⁽⁹⁴⁾ extends the resonance link even further (see figure IX-3). S_2 which goes into saturation after S_1 is to limit losses in R_1 and to decrease the voltage drop across C_0 . $R_2L_2C_2$ forms a filter to damp subharmonic oscillations. In the case of a 132 kV network Thanawala gives a power loss of 0.25% during normal operation, while fault currents are limited to 2.5 times the rated current.

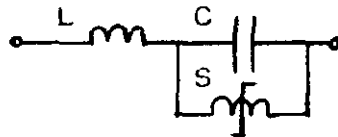

Figure IX-2. Simple Limiter Coupling with capacitor shunt.

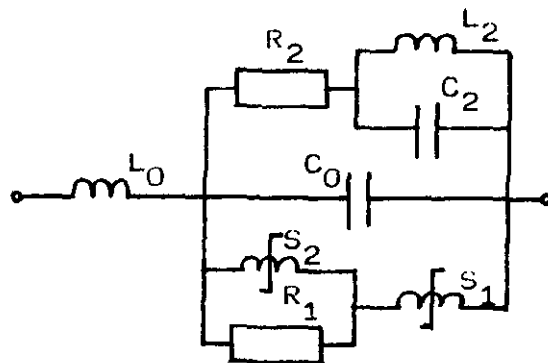

Figure IX-3. Extended Limiter Coupling with capacitor shunt.

B. Controlled Impedance Fault Current Limiter.

The principle of operation of the CIFCL has been described by Paice and Bonk (100,101). Counting with a switching time of 3 ms they calculated that in a 145 kV network with a prospective peak fault current of 121 kA the CIFCL will limit the peak fault current to 20 kA in the first half cycle and to below 8 kA after that. In order to limit peak voltages across the capacitors during the first half cycle, the circuit of figure IX-4 can be used. R_1 may be a nonlinear resistor.

The performance of this limiter is better than that of the Limiter Coupling with saturable reactors. However, it is not automatic in operation, contains more components and is therefore more expensive and less reliable.

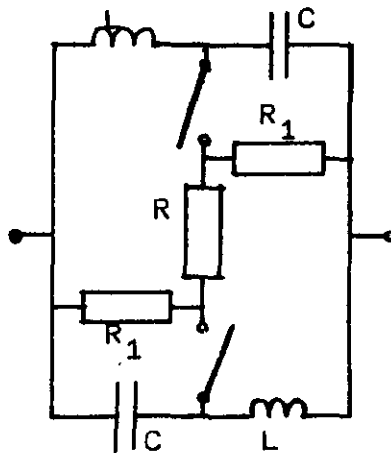

Figure IX-4. Controlled Impedance Fault Current Limiter.

REFERENCES

A. Limiter Coupling

- (92)
- Lawrenz
- , R., B.
- Uhlig
- and J.
- Köhler
- .

KRITISCHE EINSCHÄTZUNG DER RESONANZKUPPLUNG ZUR KURZ-SCHLUSS-STROMBEGRENZUNG (Critical Evaluation of the Resonance Link for Short-Circuit Current Limitation). *Energietechnik* 24 (1974) 2, p. 75-79. In German.

Requirements for CLDs are mentioned. Next the Limiter Coupling is introduced and its mode of operation explained. Its parameters are calculated and optimized, with the cost as an important factor. Economic aspects are treated; the price and the space needed per unit of power. Experiments have been performed and the results are summarized. The possibilities of integrating the CLD into the whole system are given consideration. Pros and cons are summed up.

- (93)
- Peters
- , T., J.M.

TOEPASSING VAN KORTSLUITBEGRENZERS IN DE AMERCENTRALE VAN DE N.V. PNEM (Application of Short-Circuit Limiters in the Amer Power Station of the N.V. PNEM). *Elektrotechniek* 52 (1974) 5, p. 280-284. In Dutch.

The use of the limiter coupling in the Amer power station is motivated and some advantages are mentioned. The switching mode of the station is treated extensively. The principle of operation of the limiter is explained, and based on the apparent properties of the basic circuit, the limiter is extended. Construction and security of the circuit are discussed. Finally the performance of the limiter is described.

- (94)
- Thanawala
- , H.L.

APPLICATION AND DESIGN OF SHORT-CIRCUIT LIMITING COUPLINGS. In: KIVI leergang: Toekomstaspecten in de Elektrische Energievoorziening, Eindhoven, 13-14 Jan. 1976. 's-Gravenhage: Koninklijk Instituut van Ingenieurs, 1976. P. IV/1-8.

The application of a nonlinear resonance link is described. The basic circuit is extended in order to avoid excessive

energy dissipation during normal operation and subharmonic and superharmonic oscillations. The major design parameters are discussed. Experiences with the Limiter Coupling are reviewed and future developments indicated.

(95) Järwik, J.

ANWENDUNGSMÖGLICHKEITEN DER DREHFELDDROSSELSPULEN IN ELEKTROENERGIESYSTEMEN (Application Possibilities of Reactors with Rotating Field for Electrical Energy Systems).

Elektrie 30 (1976) 3, p. 161-163. In German.

A reactor with rotating magnetic field without moving parts is described which can act as a controllable self-inductance. Several applications are dealt with, among which also short-circuit current limitation. For this purpose the reactor is used in a Limiter Coupling. Its impedance can vary over a factor 5. The reactor is about 3 times as expensive as an ordinary saturable reactor, but losses are lower and limitation is better.

(96) Chernovets, A.K. and V.S. Orlov.

LIMITATION OF SHORT-CIRCUIT CURRENTS BY MEANS OF APPARATUS OPERATING ON THE PARAMETRIC PRINCIPLE.

Power Eng. (Acad. Sci. USSR) 15 (1977) 4, p. 45-52.

Transl. of Russian article in: Izvestiya Akademii Nauk SSSR. Energetika i Transport 15 (1977) 4, p. 52-60.

A saturable reactor with rotating magnetic field is used in the Limiter Coupling. A theoretical derivation is given and checked by experiments. The reactor used admits of a simpler network and results in increased reliability.

Not consulted:

(97) Banks, R. and H.L. Thanawala.

SHORT-CIRCUIT LIMITING COUPLING AS AC SYSTEM INTERCONNECTOR.

In: Int. Conf. on High Voltage DC/AC Power Transmission, London, 19-23 Nov. 1973.

London: Institution of Electrical Engineers, 1973.

IEE Conference Publication no. 107, p. 172-176.

In interconnected systems overcurrents and voltage distur-

bances due to faults play an increasingly restrictive role. A current limiting system interconnector would avoid these restrictions. The short-circuit limiting coupling, SLC, is an a.c. tuned interconnector of this type which is inherently automatic in operation. It has a reactor in series with a capacitor, the latter being shunted by a main saturating reactor and an auxiliary one, a damping resistor and a subharmonic damping filter. The paper discusses the performance and the method of application of such devices, several of which are in commercial use. The largest SLCs now being manufactured for 2x150 MVA in a 132 kV transmission system are described.

(98) Barnes, R.

THE RESONANCE LINK AS A TRANSMISSION ELEMENT.

In: Int. Conf. on High Voltage DC/AC Power Transmission, London, 19-23 Nov. 1973.

London: Institution of Electrical Engineers, 1973.

IEE Conference Publication no. 107, p. 177-182.

The resonant link is introduced. Its salient properties are outlined and these are briefly compared to similar properties possessed by the HVDC link. In particular the link's ability to limit fault current and to be capable of actually reducing the fault level of a busbar to which other supplies are connected, is demonstrated. The possibility of protecting a series capacitor by a saturable reactor is reviewed with particular reference to the damping of subharmonic and ferroresonant instabilities on transformer feeders. Finally the problem of protecting resonant links is discussed.

(99) Zhukov, V.V., Yu.I. Zlobin and B.N. Neklepaev.

FINDING THE PARAMETERS OF THE ELEMENTS OF AN INERTIALESS CURRENT LIMITING DEVICE.

Izv. VUZ Energ. (1977) 3, p. 3-8. In Russian.

Proposes a method of selecting the parameters of a resonance-type CLD to limit the fault current in power networks. The criterion of optimality is minimum capital cost. The flow diagram is given for a computer program based on this method, and curves show the results of cal-

culations carried out for a specific power system. The method has been verified by tests on both physical and mathematical models.

B. Controlled Impedance Fault Current Limiter

(100) Paice, D.A. and J.J. Bonk.

CONTROLLED IMPEDANCE FAULT CURRENT LIMITER.

In: Symposium Proc.: New Concepts in Fault Current Limiters and Power Circuit Breakers, Buffalo, N.Y., 20-30 Sept. 1976.

Palo Alto, Cal.: Electric Power Research Institute, 1977. EPRI EL-276-SR, p. 13/1-15.

The CIFCL is described. A triggered spark gap is used as a switch. The authors conclude that in a 145 kV network with a prospective peak fault current of 121 kA the peak fault current can be limited to 20 kA even with a switching time of 3 ms. A computer analysis is made and the effect of several parameters on the behaviour of the CIFCL is considered more closely. A simple cost analysis is made. The place of the CIFCL in the entire system is discussed and attention is paid to requirements for the control network of the CIFCL.

(101) Paice, D.A. and J.J. Bonk.

CONTROLLED IMPEDANCE FAULT CURRENT LIMITER.

In: Conference Record 2nd Annual Control of Power Systems Conf. & Exposition, College Station, Tex., 14-16 March 1977. P. 14-19.

New York: Institute of Electrical and Electronics Engineers, 1977.

Contents as in (100) except for some detail differences.

X. EVALUATION

In the previous chapters we have seen that in recent years much research has been done on short-circuit current limiters. In this research a great variety of alternatives was involved. For some principles the development has already made remarkable progress, for other principles research is still in its initial stages. Therefore it is obvious that at this moment definite conclusions cannot be drawn. Yet a comparison and evaluation of recent research - as it is reviewed in this report - is possible within certain limits and is fully in its place here. But it should be constantly kept in mind that general conclusions can only be drawn most carefully and with all reserve.

CLDs will in future be installed in systems which are not matched for the available short-circuit currents and the accompanying mechanical and thermal strains. A failing limitation attempt will then lead immediately to more or less severe damage of network installations. Therefore the first and most important requirement for CLDs will be a high degree of reliability. In this respect automatic limiters are by far the most favourable. It is however to be expected that for most other principles the reliability can be increased to an acceptable level by extension of the control circuitry and by design adaptations.

Another point which will be playing a more and more important role in the course of time is the speed and degree of limitation which the CLD can reach. These determine the required load capacity of the network and in that also the time when installations have to be replaced or extended. The Limiting Coil limits overcurrent instantaneously but the degree of limitation is such that, when the trends of the past 8 years set through, it is to be expected that for many applications its role will be over in ten or twenty years. Owing to its inertia, the Current Limiting Conductor is not capable of rapid limitation. Improvements in construction and material choice may, however, lead to a better limitation during first half cycle fault current. Moreover by varying the distance between armature and core an economically attractive choice can be made between speed on the one hand and losses during

normal operation on the other. Other advantages of the CLC make it surely worth-while to look for attractive applications; in the long run however the disadvantages of inertia and low degree of limitation will probably predominate.

Except for the requirements mentioned above, which will be inevitable owing to present trends in the energy consumption, there are several other, mainly economic factors which deserve to be treated in this evaluation. These are, however, not determining for the feasibility of a CLD; for every individual situation the prevailing economic factors should be determined and from them the most attractive CLD can be chosen.

A comparative cost analysis for CLDs is definitely impossible here; the necessary data for such an analysis are lacking in the reviewed literature. In spite of that a very rough comparison can be made. For that purpose we divide the CLDs in three groups, the cheapest of which contains fuses with or without parallel elements. The second group contains the Limiting Coil and the Current Limiting Conductor. The other CLDs belong to the most expensive group.

In an adequate cost analysis a comparison of the lifetime may not fail. The fuse and the explosion switch have to be replaced after each operation. Although this does not cause any essential changes in our cost analysis, it may bring forth practical problems; after every operation the connection should be restored as quickly as possible. The best solution for that is a mechanism, e.g. a revolving device, which replaces the elements automatically, or a second element in parallel which can be inserted by means of a simple switch.

The lifetimes of switches and of vacuum and gas discharge tubes are limited as well. When the circuit is such that wear and tear occur only during a limiting operation, an adequate choice of material and construction can guarantee a lifetime that exceeds the time before the equipment becomes obsolete owing to rising short-circuit currents. The lifetimes of Limiting Coils and Limiter Couplings are very long and equal those of other circuit elements.

Especially when CLDs must fit into existing systems, the space they need becomes an important factor. Some years ago capacitors were the most place-occupying elements in CLDs. In recent years, however, modern capacitor technology has led

to the development of relatively compact devices, so that at this moment capacitors and coils require a comparative amount of space. In this respect resonance links with several coils and capacitors are unfavourable. Fuses take by far the least place.

Finally, something should be said about losses during normal operation. They form an economic factor which is not restricted to the purchase or to the limiting operation and therefore should predominate in many cases in which the purchase of a CLD is considered. When only a closed switch carries current during normal operation, the losses may be neglected. The same can be said about fuses. Other CLDs have coils and capacitors continuously connected in series with the current-carrying circuit, so that magnetic and dielectric losses occur. Mostly they are of the order of magnitude of 0.1%.

Undoubtedly there will be other economic and technical factors which are of importance to the choice of CLDs. The most important, however, have been mentioned in the foregoing. Some careful conclusions have been attached to the technical factors only. In our opinion the economic factors depend too greatly on economic developments and local circumstances. Yet it has turned out that for every situation an economically attractive choice is possible. Owing to that, CLDs can acquire an important place in present and future electric energy supply systems.

APPENDIX. AUTHOR INDEX

<u>Author:</u>	<u>year:</u>	<u>chapter:</u>	<u>reference:</u>
Albani, O.J.	1976	VIII	90
"	1977	III	37
Allen, G.D.	1977	III	30
Anderson, J.M.	1978	VI	65
Arndt, R.H.	1976	III	24
Banas, K.P.	1974	III	21
Banks, R.	1973	IX	97
Barkan, P.	1974	II	18
"	1975	II	6
"	1979	VI	66
Barnes, R.	1973	IX	98
Beehler, J.E.	1974	II	8
"	1976	II	9
"	1978	VII	86
Benz, B.A.	1979	II	14
Bhargava, B.	1977	III	25
Blevins, D.J.	1975	IV	56
Blewitt, D.D.	1973	III	27
Bleys, C.A.	1975	III	35
Bonk, J.J.	1977	IX	100
"	1977	IX	101
Bowman, C.D.	1978	VII	72
"	1979	VII	73
Braunovic, M.	1979	II	26
Carberry, R.	1979	II	14
Carroll, J.J.	1978	VI	65
Chen, W.Y.K.	1977	IV	47
Chernovets, A.K.	1977	IX	96
Clark, T.F.	1976	VIII	90
"	1977	III	37
Damsky, B.L.	1979	VI	66
Darton, K.	1978	IV	52
Datsenko, V.A.	1979	III	40
Dodds, T.H.	1976	III	41
Dollinger, R.	1978	VII	72

<u>Author:</u>	<u>year:</u>	<u>chapter:</u>	<u>reference:</u>
Dollinger, R.	1979	VII	73
Donaldson, W.A.	1974	II	5
Efimov, S.V.	1978	VIII	89
Emtage, P.R.	1976	VII	74
"	1977	VII	70
"	1977	VII	71
Falcone, C.A.	1973	II	15
"	1974	II	8
"	1974	II	17
"	1975	II	7
Ford, R.D.	1977	III	39
Fowler, D.E.	1977	IV	49
"	1978	IV	51
Fransen, H.J.F.L.M.	1976	II	13
Gallagher, H.E.	1973	VII	76
"	1978	VII	79
Gampenrieder, R.	1975	VIII	87
Gels, H.B.	1976	II	10
"	1976	II	20
Gerlach, H.	1977	IV	48
Gilmour, A.S.	1975	VII	67
"	1976	V	60
"	1976	VII	68
"	1976	VII	75
"	1977	V	61
"	1977	VII	69
"	1978	VII	72
"	1979	VII	73
Glukhikh, V.A.	1977	IV	50
Gorman, J.G.	1976	VII	74
"	1977	VII	70
"	1977	VII	71
Grawatsch, K.	1974	IV	55
"	1975	IV	45
Gray, K.E.	1977	IV	47
"	1977	IV	49

<u>Author:</u>	<u>year:</u>	<u>chapter:</u>	<u>reference:</u>
Gray, K.E.	1978	IV	51
"	1979	IV	54
Greenwood, A.	1976	II	12
Grzan, J.	1974	II	8
"	1978	VII	86
Harrowell, R.V.	1974	IV	43
"	1975	IV	44
Harvey, R.J.	1976	VII	78
"	1978	VII	79
Heberlein, J.V.R.	1977	VII	70
"	1977	VII	71
Hoek, G.A.L. van	1976	II	11
Hofmann, G.A.	1973	VII	76
"	1974	VII	77
"	1976	VII	82
"	1976	VII	83
Holmes, F.A.	1976	VII	74
"	1977	VII	70
"	1977	VII	71
Horowitz, S.H.	1979	II	14
Hudis, M.	1977	III	25
Huebener, R.P.	1977	IV	47
Imam, I.	1979	VI	66
Inaba, T.	1978	III	32
Järwik, J.	1976	IX	95
Keders, T.	1976	III	36
Kennon, R.	1976	II	19
Kimblin, C.W.	1976	VII	74
"	1977	VII	70
"	1977	VII	71
King, H.J.	1977	VII	85
"	1978	VII	86
Knauer, W.	1975	VII	81
"	1977	VII	84
"	1977	VII	85
"	1978	VII	86

<u>Author:</u>	<u>year:</u>	<u>chapter:</u>	<u>reference:</u>
Knauer, W.	1979	II	14
Köfler, H.	1975	IV	45
Köhler, J.	1974	IX	92
Komarek, P.	1975	IV	45
Kornmann, H.	1975	IV	45
Korol'kov, V.L.	1979	III	40
Kostenko, A.I.	1977	IV	50
Kotski, E.J.	1976	III	24
Kroon, P.J.	1979	III	42
Kruit, D.	1973	I	4
Kuchumov, L.A.	1976	VIII	88
LaBarbera, G.L.	1976	VII	82
"	1976	VII	83
Lawrenz, R.	1974	IX	92
Lebely, D.	1975	III	35
Lee, I.	1979	II	14
Leibold, A.A.	1976	III	36
Lenihan, T.	1979	IV	54
Leroux, B.	1979	III	38
Lewis, W.A.	1977	III	30
Lian, K.T.	1974	VII	80
Lindsay, J.D.G.	1975	IV	56
Lipski, T.	1973	III	28
Lockwood, D.L.	1975	VII	67
Long, W.F.	1974	VII	80
Lutz, M.A.	1973	VII	76
"	1974	VII	77
"	1976	VII	78
"	1978	VII	79
Malone, D.P.	1978	VII	72
"	1979	VII	73
Manders, A.H.E.	1976	II	11
Marshall, J.D.	1976	V	60
"	1977	V	61
McConnell, L.D.	1974	II	5
Mekolites, W.E.	1974	II	8

<u>Author:</u>	<u>year:</u>	<u>chapter:</u>	<u>reference:</u>
Monoszon, N.A.	1977	IV	50
Müller, K.	1977	IV	48
Narancic, V.	1979	III	26
Neklepaev, B.N.	1973	II	16
"	1977	IX	99
"	1978	VIII	89
Nichols, T.O.	1974	III	22
Orlov, V.S.	1977	IX	96
Paice, D.A.	1977	IX	100
"	1977	IX	101
Papadias, B.C.	1975	VI	62
"	1977	VI	63
"	1978	VI	64
Papp, K.	1975	VIII	87
Perry, E.R.	1974	II	5
Peters, T.J.M.	1974	IX	93
Pflanz, H.M.	1976	VIII	90
"	1977	III	37
Popeck, C.A.	1977	III	30
Premerlani, W.J.	1975	V	59
"	1979	VI	66
Rau, N.S.	1976	III	41
Reed, N.E.	1976	VII	82
"	1976	VII	83
Reimann, C.	1976	II	10
"	1976	II	20
Rioux, C.	1975	III	35
Rioux-Damidau, F.	1975	III	35
"	1977	III	38
Rothernbuhler, W.N.	1976	III	42
Schmieder, R.W.	1975	IV	46
Shell', A.R.	1979	IV	58
Shillong, L.A.	1976	VII	82
"	1976	VII	83
Shimkevich, G. Ya.	1979	III	40
Slade, P.G.	1976	VII	74

<u>Author:</u>	<u>year:</u>	<u>chapter:</u>	<u>reference:</u>
Slade, P.G.	1977	VII	70
"	1977	VII	71
Steinwender, D.	1975	VIII	87
Tarczon, J.	1979	IV	55
Thanawala, H.L.	1973	IX	97
"	1976	IX	94
Tishchenko, V.A.	1977	IV	50
Trokhachev, G.V.	1977	IV	50
Turner, C.	1973/79	III	33
Turner, H.W.	1973/79	III	33
Uhlig, B.	1974	IX	92
Ulbricht, A.	1975	IV	45
"	1979	IV	53
Utegulov, N.I.	1976	VIII	88
van Hoek, G.A.L.	1976	II	11
Vermij, L.	1975	III	23
Vitkovitsky, I.M.	1977	III	39
Vojnovich, T.	1973	III	27
Voshall, R.E.	1976	VII	74
"	1977	VII	70
"	1977	VII	71
Westrom, A.C.	1979	III	26
Wieringa, L.	1977	III	34
Wilson, D.D.	1974	II	18
Withers, J.S.	1977	III	31
Young, B.	1975	III	29
Zhukov, V.V.	1977	IX	99
Zlobin, Yu.I.	1977	IX	99

EINDHOVEN UNIVERSITY OF TECHNOLOGY
THE NETHERLANDS
DEPARTMENT OF ELECTRICAL ENGINEERING

Reports:

- 93) Duin, C.A. van
DIPOLE SCATTERING OF ELECTROMAGNETIC WAVES PROPAGATION THROUGH A RAIN MEDIUM. TH-Report 79-E-93. 1979. ISBN 90-6144-093-9
- 94) Kuijper, A.H. de and L.K.J. Vandamme
CHARTS OF SPATIAL NOISE DISTRIBUTION IN PLANAR RESISTORS WITH FINITE CONTACTS. TH-Report 79-E-94. 1979. ISBN 90-6144-094-7
- 95) Hajdasinski, A.K. and A.A.H. Damen
REALIZATION OF THE MARKOV PARAMETER SEQUENCES USING THE SINGULAR VALUE DECOMPOSITION OF THE HANKEL MATRIX. TH-Report 79-E-95. 1979. ISBN 90-6144-095-5
- 96) Stefanov, B.
ELECTRON MOMENTUM TRANSFER CROSS-SECTION IN CESIUM AND RELATED CALCULATIONS OF THE LOCAL PARAMETERS OF Cs + Ar MHD PLASMAS. TH-Report 79-E-96. 1979. ISBN 90-6144-096-3
- 97) Worm, S.C.J.
RADIATION PATTERNS OF CIRCULAR APERTURES WITH PRESCRIBED SIDELobe LEVELS. TH-Report 79-E-97. 1979. ISBN 90-6144-097-1
- 98) Kroezen, P.H.C.
A SERIES REPRESENTATION METHOD FOR THE FAR FIELD OF AN OFFSET REFLECTOR ANTENNA. TH-Report 79-E-98. 1979. ISBN 90-6144-098-X
- 99) Koonen, A.M.J.
ERROR PROBABILITY IN DIGITAL FIBER OPTIC COMMUNICATION SYSTEMS. TH-Report 79-E-99. 1979. ISBN 90-6144-099-8
- 100) Naidu, M.S.
STUDIES ON THE DECAY OF SURFACE CHARGES ON DIELECTRICS. TH-Report 79-E-100. 1979. ISBN 90-6144-100-5
- 101) Verstappen, H.L.
A SHAPED CYLINDRICAL DOUBLE-REFLECTOR SYSTEM FOR A BROADCAST-SATELLITE ANTENNA. TH-Report 79-E-101. 1979. ISBN 90-6144-101-3
- 102) Etten, W.C. van
THE THEORY OF NONLINEAR DISCRETE-TIME SYSTEMS AND ITS APPLICATION TO THE EQUALIZATION OF NONLINEAR DIGITAL COMMUNICATION CHANNELS. TH-Report 79-E-102. 1979. ISBN 90-6144-102-1
- 103) Roer, Th.G. van de
ANALYTICAL THEORY OF PUNCH-THROUGH DIODES. TH-Report 79-E-103. 1979. ISBN 90-6144-103-X
- 104) Herben, M.H.A.J.
DESIGNING A CONTOURED BEAM ANTENNA. TH-Report 79-E-104. 1979. ISBN 90-6144-104-8

**EINDHOVEN UNIVERSITY OF TECHNOLOGY
THE NETHERLANDS
DEPARTMENT OF ELECTRICAL ENGINEERING**

Reports:

- 105) Videc, M.F.
STRALINGSVERSCHILNSELEN IN PLASMA'S EN BEWEGENDE MEDIA: Een geometrisch-optische en een golfzonebenadering.
TH-Report 80-E-105. 1980. ISBN 90-6144-105-6
- 106) Hajdasiński, A.K.
LINEAR MULTIVARIABLE SYSTEMS: Preliminary problems in mathematical description, modelling and identification.
TH-Report 80-E-106. 1980. ISBN 90-6144-106-4
- 107) Heuvel, W.M.C. van den
CURRENT CHOPPING IN SF₆.
TH-Report 80-E-107. 1980. ISBN 90-6144-107-2
- 108) Etten, W.C. van and T.M. Lammers
TRANSMISSION OF FM-MODULATED AUDIOSIGNALS IN THE 87.5 - 108 MHz BROADCAST BAND OVER A FIBER OPTIC SYSTEM.
TH-Report 80-E-108. 1980. ISBN 90-6144-108-0
- 109) Krause, J.C.
SHORT-CURRENT LIMITERS: Literature survey 1973-1979.
TH-Report 80-E-109. 1980. ISBN 90-6144-109-9
- 110) Matacz, J.S.
UNTERSUCHUNGEN AN GYRATORFILTERSCHALTUNGEN.
TH-Report 80-E-110. 1980. ISBN 90-6144-110-2
- 111) Otten, R.H.J.M.
STRUCTURED LAYOUT DESIGN.
TH-Report 80-E-111. 1980. ISBN 90-6144-111-0 (in preparation)
- 112) Worm, S.C.J.
OPTIMIZATION OF SOME APERTURE ANTENNA PERFORMANCE INDICES WITH AND WITHOUT PATTERN CONSTRAINTS.
TH-Report 80-E-112. 1980. ISBN 90-6144-112-9
- 113) Theeuwen, J.F.M. en J.A.G. Jess
EEN INTERACTIEF FUNCTIONEEL ONTWERPSYSTEEM VOOR ELEKTRONISCHE SCHAKELINGEN.
TH-Report 80-E-113. 1980. ISBN 90-6144-113-7
- 114) Lammers, T.M. en J.L. Manders
EEN DIGITAAL AUDIO-DISTRIBUTIESYSTEEM VOOR 31 STEREOKANALEN VIA GLASVEZEL.
TH-Report 80-E-114. 1980. ISBN 90-6144-114-5