

Connecting office buildings to the smart grid

Citation for published version (APA):

Goch, van, T. A. J. (2014). *Connecting office buildings to the smart grid: harvesting flexibility*. [EngD Thesis]. Technische Universiteit Eindhoven.

Document status and date:

Published: 01/01/2014

Document Version:

Publisher's PDF, also known as Version of Record (includes final page, issue and volume numbers)

Please check the document version of this publication:

- A submitted manuscript is the version of the article upon submission and before peer-review. There can be important differences between the submitted version and the official published version of record. People interested in the research are advised to contact the author for the final version of the publication, or visit the DOI to the publisher's website.
- The final author version and the galley proof are versions of the publication after peer review.
- The final published version features the final layout of the paper including the volume, issue and page numbers.

[Link to publication](#)

General rights

Copyright and moral rights for the publications made accessible in the public portal are retained by the authors and/or other copyright owners and it is a condition of accessing publications that users recognise and abide by the legal requirements associated with these rights.

- Users may download and print one copy of any publication from the public portal for the purpose of private study or research.
- You may not further distribute the material or use it for any profit-making activity or commercial gain
- You may freely distribute the URL identifying the publication in the public portal.

If the publication is distributed under the terms of Article 25fa of the Dutch Copyright Act, indicated by the "Taverne" license above, please follow below link for the End User Agreement:

www.tue.nl/taverne

Take down policy

If you believe that this document breaches copyright please contact us at:

openaccess@tue.nl

providing details and we will investigate your claim.

Connecting office buildings to the smart grid

T.A.J. van Goch



CONNECTING OFFICE BUILDINGS
TO THE SMART GRID:
HARVESTING FLEXIBILITY

T.A.J. van Goch
February, 2014

EINDHOVEN UNIVERSITY OF TECHNOLOGY

Stan Ackermans Institute

SMART ENERGY BUILDINGS & CITIES

CONNECTING OFFICE BUILDINGS TO THE SMART GRID:
HARVESTING FLEXIBILITY

By

T.A.J. van Goch, MSc.

A dissertation submitted in partial fulfillment of
the requirements for the degree of
Professional Doctorate of Engineering

Eindhoven, the Netherlands

February 2014

This thesis has been established in collaboration with



©2014
T.A.J. van Goch
All Rights Reserved
Eindhoven University of Technology

A catalogue record is available from the Eindhoven University of Technology Library

ISBN: 978-90-444-1261-1
(Eindverslagen Stan Ackermans Instituut ; 2014/003)

A dissertation submitted in partial fulfillment of
the requirements for the degree of
Professional Doctorate of Engineering

CONNECTING OFFICE BUILDINGS TO THE SMART GRID:
HARVESTING FLEXIBILITY

A framework that enables flexible control of building processes,
and analyses of the potential value of flexibility in office buildings.

Author:

T.A.J. van Goch, MSc.

Stan Ackermans Institute for Technological Design
Smart Energy Buildings & Cities

Supervisors:

Prof. ir. W.L. Kling

Professor of Sustainable Energy Systems
Faculty of Electrical Engineering
Section Electrical Energy Systems

M.P.F. Hommelberg, MSc.

BAM Techniek

This thesis has been established in collaboration with Eindhoven University of
Technology, BAM Techniek, Kick InnoEnnergy.

February 2014

Abstract

Traditionally, the electricity system is oriented top- down and buildings are just energy consumers. Since electricity is expensive to store, supply and demand have to be balanced at all times. In the nearby future, the electricity system must be able to cope with an increase in intermittent decentralized energy production. Also, ongoing electrification is expected to contribute to an increase in demand. Demand side management and control is needed to ensure reliability of supply at acceptable costs.

Buildings can be a part of the solution as they can offer flexibility in energy consumption and/or production. By enabling flexible control of processes on the building premises, the building can provide balancing services and respond to congestion problems in the power system, while user comfort can be guaranteed.

For the engineering company BAM Techniek, it is of importance to know how the integration of such smart grid technologies in buildings can contribute to (energy) service provision. This study focusses on the enabling of flexibility in energy consumption and generation, while comfort is guaranteed. The project aims to create a framework that enables flexible control of building processes, and analyses of the potential value of flexibility in office buildings. The proposed framework consists of a technical solution, and an analysis of the economical benefits.

Priority based control is introduced to enable flexible control of building processes. The concept is capable of prioritizing the energy consumption of processes, and controlling the consumption depending on the needs of the electricity market. An empty office has for instance, a low priority to consume energy. User needs are integrated in the prioritization mechanisms. This mechanism ensures that processes stay within the allowed bandwidth, while providing flexibility to the power system. Since the priority based control connects the end user needs to the market needs, a bi-directional flow of information is required.

The Eneco World Office is used to perform a building case study to test the technological framework. Three sources of flexibility are investigated: decentralized climate systems, electric vehicles, and a sensible heat buffer. Results show that the amount of available flexibility depends mainly on load profiles and comfort settings. Electric vehicles and the sensible heat buffer provide significant amounts of flexibility. The flexibility in decentralized climate systems is limited since the room air temperature responds relatively fast to changes in settings and comfort boundaries are quickly met. The long term effect of storage in the building inertia should however be investigated further.

Economical benefits can be created by using the variation in costs on the wholesale market caused by market volatility. When flexibility is used to contribute to the balance in a portfolio of buildings, the imbalance can be reduced, which leads to a reduction in costs. Finally, flexibility can contribute to a reduction in peak demand of buildings, leading to cost savings in the network connection.

The need for smart grids is growing, while energy services are becoming more important in the built environment. Considering the potential value of smart grid services in the built environment and the market size, it is evident that the developing smart grid market presents opportunities for BAM Techniek. The provision of flexibility services can be a valuable addition to the energy services portfolio.

To my mother
To my brothers
To my father †
To my sister †

To Moniek

Acknowledgments

I would like to thank BAM Techniek for providing the opportunity to participate in this program and thereby extending my skills. I thank the TU/e and all staff members of the SEB&C program for their contributions to the program, workshops and projects. ESADE, KTH and UPC provided some of the most interesting ideas, insights and lectures of the program. I also want to thank KIC making this program possible.

I thank Professor Kling his guidance and help in the last year. I'm grateful for the opportunity to work with Maarten Hommelberg. His knowledge and guidance, in particular in realizing this writing were indispensable. I want to thank Linda Pennings for her support and ideas throughout the project. I've learned a lot and more from the both of you. Francesco Franchimon, thank you for your confidence in me. Without all my colleagues at BAM, Bunnik might have felt even further away. I'm looking forward to work with you in the future.

The opportunity to work in the Smart Energy Collective 'Offices' project team was essential for my assignment and experience, thanks to all of you for making it a good experience.

I would like to thank Alexander Suma, for all the help in the finalization of the project, for friendship and for Barcelona. Roy Hamans, for his guidance and the valuable feedback. Audrey Debije-Popson for reviewing my writing and Larisa Camfferman for teaching me about pancakes and her contribution to my skill development.

I'm happy to have had such interesting colleagues in the program of whom I've learned so much, I thank all of you. Krijn, you provided the proof that there is more to architects and I appreciated working, agreeing and disagreeing with you. Farooq, thanks for being so stubborn and knowledgeable on math, it has led to interesting discussions.

Without my friends I might have been tempted to write twice as much, I think everybody will thank you for that. Moniek, without you I would have lost it long before writing this, love,

Dennis

- Eindhoven, January 2014

Preface

This work is part of the final product of the Smart Energy Buildings & Cities PDeng. program of the Stan Ackerman Institute for Technological Design and BAM Techniek. The last two years I've been working on my Professional Doctorate in Eindhoven, Stockholm, Barcelona and Bunnik. The technological design assignment has been performed for BAM Techniek; the technical part of the result of this one year study is incorporated in this report.

I remember a professor saying; this program is something which suits you perfectly (before literally sailing away). Being the first generation of anything always leads to challenges. Or, as one very knowledgeable person said 'the first pancake always fails'. Tight schedules, changing organization and the workload made for a winding road. It has been a turbulent couple of years for reasons other than the program as well. I am very grateful that people who are close to me found a place and succeeded in reaching their goals.

My background is in advanced building simulations and sustainable energy technology. Combining building services, simulation, ICT and energy systems and business development is challenging, in particular considering the time constraints. On the other hand; I've never learned this much in a couple of months. Although I had some experience in electrical engineering, the smart grid is a complex matter. Or like Mandelbrot described fractal systems, which might resemble the future energy system: "beautiful, damn hard, and increasingly useful".

Before I chose to pursue a PDeng. I wanted to be an engineer, so I played with lego. I wanted to be an architect, so I started drawing. I wanted to be a fighter pilot, so I took the tests. I wanted to know how things work, so I studied physics, I wanted to make a difference, so I looked into the energy that drives the world, I wanted to solve a puzzle, so I looked at myself. Luckily there are enough challenges remaining in the transitions of the building service sector and energy sector alike.

Dennis
- Eindhoven, January 2014

Table of Contents

LIST OF FIGURES	vii
LIST OF TABLES	viii
LIST OF ABBREVIATIONS	ix

Chapter

1	INTRODUCTION	1
	1.1 Background	1
	1.2 Context	2
	1.3 Concept	2
	1.4 Main questions in this study	3
	1.5 Objectives	3
	1.6 Methodology	3
	1.7 Scope	4
	1.8 Structure of the report	5
2	THE ENERGY AND BUILDING SERVICES SECTORS	6
	2.1 Stakeholder needs	6
	2.1.1 ... in the built environment	6
	2.1.2 ... in the energy sector	8
	2.2 The electricity market	8
	2.2.1 Operation of the electrical power system	8
	2.2.2 Electricity market prices	10
	2.3.3 Legislation changes	11
	2.2.4 New market roles	11
	2.3 Economical value of flexibility in the electricity system	11
	2.4 The building services sector	12
	2.4.1 Energy service models	12
	2.4.2 Technological development of building management systems	12
	2.4.3 Smart grid integration in building management systems	13
	2.5 Smart grid projects	13
	2.6 Required technological and process innovation	14
3	INTEGRATION OF SMART GRID SERVICES	
	IN OFFICE BUILDINGS	16
	3.1 Providing and measuring comfort	16
	3.2 Design elements	18
	3.3 Evaluating flexibility	19
	3.3.1 Sources of flexibility	19
	3.3.2 Expressing flexibility	21
	3.3.3 Analysis of the available flexibility	21
	3.4 Concepts for enabling flexibility	22
	3.4.1 The PowerMatcher principle	22
	3.4.2 Priority based control	23
	3.4.3 Local process control	25
	3.4.4 Aggregation and matching	25
	3.4.5 Business entity (valuation)	26
	3.4.6 Forecasting flexibility	26

3.4.7	Global demand forecasting	27
3.5	Flexibility and efficiency	27
3.6	Practical implementation	28
4	BUILDING CASE STUDY	30
4.1	Case background	30
4.2	Description of building	30
4.3	Example of demand forecasting	31
4.4	Available flexibility	32
4.4.1	..from decentralized climate systems	32
4.4.2	..from electric vehicles	37
4.4.3	..from storage buffer	39
4.5	Market based optimization	41
4.5.1	... of decentralized climate systems	41
4.5.2	... of electric vehicle charging	43
4.5.3	... of a buffer vessel	43
5	MARKET OPPERTUNITIES FOR PROVISION OF FLEXIBILITY SERVICES	45
5.1	Evaluation of market status and growth	45
5.1.1	Energy and smart grid	45
5.1.2	Opportunities in the building industry	46
5.1.3	Office buildings as a target segment	47
5.2	Feasibility of flexibility services	48
5.2.1	Potential of case study examples	48
5.2.2	The value of participating on wholesale markets	48
5.3	Business Innovation	49
6	DISCUSSION	50
7	CONCLUSIONS	51
8	RECOMMENDATIONS FOR BAM	53
	LITERATURE	54
	APPENDIX A: Global demand forecasting	60
	APPENDIX B: Process models	65

List of Figures

Figure

1	Research methodology.....	4
2	Representation of stakeholders in the energy service sector.....	6
3	Value perception of different stakeholders in the office environment.....	7
4	Schematic overview of electricity system.....	8
5	Technical and economic operation of the Dutch power system.....	9
6	Example of the Dutch imbalance market.....	10
7	Example of spot market settlement on the Dutch APX market.....	11
8	Smart grid development timeline.....	14
9	M490 reference model for smart grid design and integration.....	15
10	Example of PMV and PPD curves.....	16
11	Design elements that influence design requirements.....	17
12	Process for evaluating building flexibility.....	19
13	Sources of flexibility on the building premises.....	20
14	Schematic representation of process models.....	21
15	Principle representation of flexibility forecast in a graph.....	22
16	PowerMatcher agent cluster.....	23
17	Modules for implementation of priority control.....	24
18	Bid functions, the relation between power and priority.....	25
19	Determination of the optimal path.....	26
20	Priority based control process.....	27
21	Implementation of flexible control in an existing building.....	28
22	Potential implementation of flexible control in a new building.....	29
23	Load - Duration curve for Eneco World Office.....	31
24	Energy forecast for a week in June (2012).....	31
25	Free floating temperature of a room.....	33
26	Example of bid curves for the room climate control.....	33
27	Flexibility graphs for different occupancy scenarios.....	34
28	Flexibility graphs for different ‘exposures’ of the thermal mass.....	34
29	Example of heat transfer through the system boundaries.....	35
30	Example of effect of preheating the building mass.....	35
31	Flexibility of decentralized climate system winter.....	36
32	Flexibility of decentralized climate system summer.....	36
33	Flexibility of electric vehicle fleet with different user profiles.....	38
34	Electric car flexibility during a single day.....	38
35	Buffer size versus storage capacity.....	40
36	Flexibility curves for sensible heat buffer.....	40
37	Priority response to price signal.....	41
38	Optimized temperature for different price signals.....	42
39	Optimized energy consumption for different price signals.....	42
40	Optimizations for EV charging.....	43
41	Optimal buffer operation.....	44
42	Smart energy services.....	45
43	Smart grid market growth in the US.....	46
44	Forecasted and realized consumption for a portfolio of buildings.....	49

List of Tables

Table

1	Potential sources of flexibility in office buildings	20
2	General description of available process models	22
3	Eneco World Office building electricity demand data	30
4	Available flexibility from decentralized heating and cooling	37
5	Overview of electric vehicle charging points	37
6	Available flexibility from electric car	39
7	Available flexibility from a sensible storage buffer	41

List of Abbreviations

ANN	Artificial Neural Network
APX	Amsterdam Power Exchange
CAPEX	Capital Expenditure
CAV	Constant Air Volume
COP	Coefficient of Performance
DSM	Demand Side Management
DSO	Distribution System Operator
ENDEX	European Energy Derivatives Exchange
EV	Electric Vehicle
EWO	Eneco World Office
ESCo	Energy Service Company
IPIN	Innovation Program Intelligent Networks (in Dutch: <i>Innovatieprogramma Intelligente Netten</i>)
OPEX	Operating Expense
PMV	Predicted Mean Vote
PPD	Percentage People Dissatisfied
PPP	Public Private Partnership
PRP	Program Responsible Party
PTU	Program Time Unit
SEC	Smart Energy Collective
SOC	State Of Charge
TCO	Total Cost Ownership
TSO	Transmission System Operator
TVO	Total Value Ownership
VPP	Virtual Power Plant

Chapter 1: Introduction

Transitions in the energy and construction sectors are leading to new opportunities for energy service provision in buildings, as the smart grid paradigm is adopted. What can smart grid developments offer to buildings, while considering the needs of the building owner and users? And what can buildings offer to the smart grid? This chapter includes an introduction to the performed study, the methodology and the goals.

1.1 Background

Two major forces are currently influencing the building industry: The crisis in the construction sector and the energy transition. The crisis in the construction sector leads to a need to change building construction and exploitation practices [1]. To be able to compete in the future, companies active in the construction sector have to offer solutions that satisfy stakeholder desires during the whole life cycle of the building. Functional flexibility and lifecycle costs are important themes. Increased performance in terms of energy and comfort means that a service orientation is required to fulfil the needs of the building users and owners.

The changes in the construction sector offer new opportunities for companies active in the built environment to expand their activities by offering new services related to energy, and comfort optimization [2]. Buildings are responsible for 30-40% of the primary energy demand [3]. As such, energy efficiency is an important performance aspect. The demand for long term performance guarantees leads to risks. Capital intensive assets are located on the client premises, where multiple processes may influence each other's services. Other risks include the uncertain lifecycle performance of the building components and volatile energy prices.

Meanwhile, the energy sector is in a phase of transition. Concerns about growing energy demand in relation to security of supply, energy costs and environmental issues have led to a growing interest in renewable energy systems [4]. It is expected that in 2030, 8.6% of the global electricity consumption will be generated from non-hydro sustainable sources [4], while EU targets for 2020 are for a 20% share of renewable energy [5]. It is expected that a large part of the renewable energy will be produced from decentralized sources [6]. In the nearby future, the grid must be able to cope with large amounts of intermittent-, decentralized energy production and demand. The intermittent nature of sustainable energy sources will lead to a loss of system flexibility in terms of generation control and balancing potential [6,7]. At the same time, ongoing electrification is expected to contribute to an increase in demand [8,9].

Traditionally, the energy market has a top down orientation in which consumers have limited influence. Production was demand-based and controlled through adjusting the production from large central generation units. Such a rigid structure will not suffice for the future: meeting the (technical) demands for transport capacity and reserve power will become increasingly costly as electricity demand increases and the share of intermittent generators grows. Demand side management (DSM) and control is needed to ensure reliability of supply at acceptable costs.

Buildings can be a part of the solution to these challenges, as they can offer flexibility in energy consumption and/or production. Buildings are becoming integrated parts of the energy infrastructure, actively trading on the energy markets. This integration of buildings in the energy system and the ability to interact with other stakeholders requires an 'upgrade' of the energy infrastructure, to enable bi-directional power and information flow.

The "smart grid" describes the evolution of the energy infrastructure needed to be able to provide services like local production- and demand flexibility.

The expected paradigm shift related to the adoption of smart grid technologies in the energy market offers opportunities for companies as new market roles emerge, and the relations between stakeholders change. New services can be developed for building- and asset management as the energy sector becomes a more important stakeholder in the built environment. In the building industry, increased energy efficiency and comfort demands lead to a more service oriented industry in which the smart grid will play an important role in order to optimize performance and minimize costs.

1.2 Context

Interaction between buildings and the smart grid requires the exchange of signals between different stakeholders and the establishment of control strategies that optimize services for all stakeholders without compromising basic constraints. Participating on energy markets introduces challenges in the buildings as energy costs may not be the only important value for building owners and users. One of the important questions therefore regards what the smart grid can offer to buildings.

While interaction with the grid may contribute to local cost optimization, flexibility could be offered to external parties so they are able to operate more effectively. Parties active on the energy markets have, for instance, the responsibility to provide balance supply and demand and behave according to a planning. When considering responsibilities such as balancing, one of the important questions is what services the building can offer to the smart grid and what the value of these values is.

The smart grid is an essential evolution of the energy infrastructure to ensure stable and affordable energy supply in the future. However, diverging technological developments, costs uncertainties, changing markets and the lack of general design- and technology frameworks pose major challenges for the implementation of smart grid concepts and the development of successful business cases [6,7].

Part of this study is linked to a project that aims to demonstrate the implementation of smart grid services and the related business cases in the Eneco World Office (EWO). The project is executed by the Smart Energy Collective (SEC) which consists of companies related to the built environment, energy services and ICT who want to take an integrated, cooperative approach in developing smart grid services and systems. SEC initiated five demonstration locations, one of which is focussed on offices (EWO). Here, BAM Techniek, Eneco, Priva and GEN are investigating opportunities to shift energy demand to gain advantages on the market [10].

1.3 Concept

The interaction between the building and its environment will become more important in the future, as the boundary between the building installations and the grid infrastructure disappears. For a building to participate in the energy market, the building needs to respond to market needs. By enabling flexible control of processes on the building premises, the building can provide balancing services and respond to congestion problems in the transport system, while building performance can be guaranteed. To enable flexible operation, the building's inertia could for instance be used to postpone consumption. Priority based control, in which energy consumption is prioritized within allowable comfort bandwidths depending on immediate and future needs, is an example of a control type that could be used to enable flexible operation.

1.4 Main questions in this study

This study focusses on the development of a building management solution that enables flexibility in the energy consumption and/or production of buildings, thereby providing value for the user and to the electrical energy system.

For BAM Techniek, it is of importance to know how the integration of smart grid technology in buildings can contribute to service provision, and if this leads to feasible business cases. Therefore, a framework for enabling flexible control of buildings needs to be developed, as well as methods for analysing flexibility and the potential value of these services. Central questions in this study are:

- a. How can flexibility in energy consumption and generation be enabled with priority based control while efficiency and comfort are guaranteed?
- b. What assets and protocols are required to manage the interaction with the power system, and what signals need to be exchanged with whom?
- c. What services can be offered when connecting buildings to energy markets?
- d. What is the value of these services when considering different stakeholders and their interests?

This study will lead to a framework for a flexible energy management solution for office buildings. The analysis of flexibility and value is an important part of the study, and provides the basis for a business plan and analysis tools for flexibility evaluation.

1.5 Objectives

The objectives of the technological design study are threefold, focusing on technical design, demonstration and value creation. The objectives of this study are:

- Establish a design for a control framework that enables flexibility in the energy consumption and/or production of office buildings.
- Demonstrate the developed framework in a building case study.
- Develop business cases for the purpose of integrating flexibility services in energy service provision.

1.6 Methodology

An overview of the methodology is included in figure 1 (page 4). First, a literature survey was conducted to investigate smart grid design principles and the current smart grid projects. Furthermore, building management systems and comfort aspects were investigated. The design of the framework to enable flexible control is based on the analysis of stakeholder needs (expert opinion) and prior research findings.

The EWO is used as building case study to test the technological framework for enabling flexibility. After the initial literature survey, the installations and energy flows of the EWO have been analysed. The analysis consisted of an energy audit (visit and interviews), analysis of energy profiles, and analysis of installations that are currently present in the building. Sources of flexibility were selected based on the expected flexibility potential and controllability. A balance between learning goals of partners in the SEC project, applicability, and the time horizon influenced this choice.

For the purpose of analysing the available flexibility in the EWO, process models were derived for decentralized heating/cooling, sensible energy storage and electric vehicle charging. The models are needed for flexibility analysis, and for real-time control. A first order approach was chosen to offer low computational complexity and scalability. Process models were initially built in Excel to ensure simplicity and compatibility with current processes at BAM. It was found that for a priori analysis of the flexibility of climate systems, full dynamic modelling environment should be used to provide more insight of the influence

of flexibility on building operation. Such models are computationally intensive, but offer a more insight in the long term effects of heat storage on the energy efficiency, flexibility and user comfort. For a real-world implementation, the simplified process models can be used. The Excel model results have been compared to ESP-r results (dynamic building simulation tool) for validation purposes.

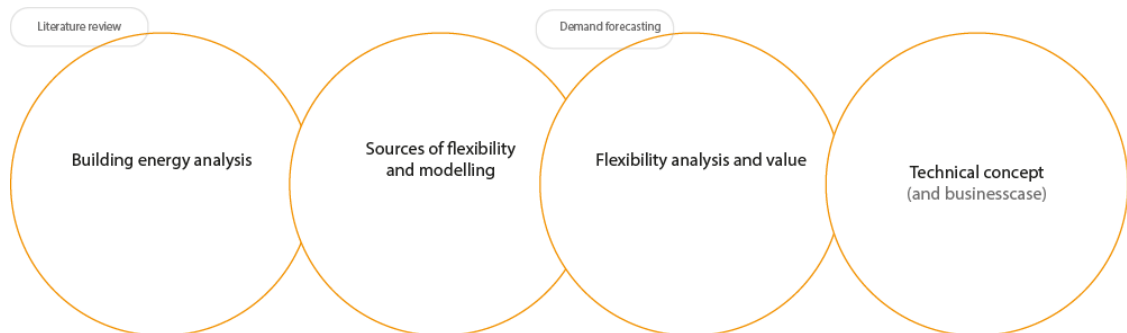

Figure 1: Research methodology.

The value of flexibility is determined by comparing the available flexibility to electricity market prices. A Matlab implementation (based on the Excel models) was developed to test optimization methods which are needed to find the most cost effective moments to use flexibility. Optimization strategies based on linear dynamic programming have been used to analyse potential value of the flexibility. For energy forecasting purposes, several predictive schemes have been tested. The final forecasting method is based on artificial neural network methods.

The technological design for the flexible control of building processes consists of the process models and the optimization methods. The technological framework is based on existing smart grid control concepts and proven technologies found in literature. This includes the design elements as derived from the stakeholder analysis, and prior research. The unique value for BAM is in the process models and translation between aggregated signals and control signals. Attention was given to the boundary conditions needed for implementation; ICT infrastructure and hardware. Initial interfacing designs and protocols have been developed for integrating the framework in the building. Separate modules are suggested containing process models, general energy demand forecasting and optimization components. The modules can be separately developed and integrated in agents for implementation.

The economical value of flexibility is determined by the smart grid markets. The economic potential of flexibility also depends on the required investment, market opportunities in the built environment and possible services offerings. Therefore, a market analysis has been performed. It was concluded that flexibility services offer value in combination with energy trade and other 'smart services', such as continuous commissioning and monitoring. The technological framework and business cases will be tested in the EWO in 2014.

1.7 Scope

The project aim is to develop a framework that enables flexible control and to determine the potential value of flexibility services. This requires investigation of current technologies, required partners, analysis methods, and control concepts. An office building interacting with the markets and its immediate environment will be considered. The technical design of the electricity infrastructure is not part of this study and will not be considered in detail. The framework will be based on existing technologies and protocols, although the forecasting models and the implementation will be newly designed.

The implementation of the framework is not part of the goal of this project; this requires extensive ICT knowledge, which is beyond the scope of this project. Implementation of the flexibility control system is envisioned to take place in the case study building in 2014. The technological design will consist of a framework for enabling flexibility and methods for analysing flexibility.

1.8 Structure of the report

In Chapter 2, a more detailed overview of the Dutch electricity market and the user needs is provided as basis for the technological design. Furthermore, current smart grid related projects and developments in building management systems are introduced. Besides the costs of electricity, also the potential value of flexibility on the markets is introduced. Chapter 2 provides the context for the design. Chapter 3 contains the framework to enable flexible operation of processes (sub questions a and b). The chapter starts with the design aspects and requirements. Next, the concept of priority based control is introduced. Finally, the required infrastructure is discussed. A building case study has been performed based on the technology framework, which is introduced in chapter 4 (sub question b, c and d). The valuation/optimisation methods are demonstrated in chapter 4 based on market. In chapter 5, the market opportunities for smart grid service provision is discussed. A further discussion is done in chapter 6. Conclusions and recommendations for BAM are included in chapters 7 and 8 respectively. This report is publicly available, details about the models, optimisation and business cases are therefore not included.

Chapter 2: The energy and building services sectors

The framework to enable flexible control of building processes is developed in the context of office buildings and the electrical power supply. In order to investigate the potential value of flexibility and to design an effective management concept, an analysis of the stakeholder needs, the current markets, and developments is required. In this chapter the energy and building services markets and changes in these markets are discussed. Based on the analysis of the electricity markets, the economical value of flexibility is introduced.

2.1 Stakeholder needs

The built environment is a complex area involving many stakeholders. Buildings form the backbone of our culture and economy and as such, are of importance to everybody. The functions of buildings address basic needs such as shelter and safety, as well as providing community value and identity. Buildings represent a high social and economic value. The value perception is however different for each stakeholder. Users and other stakeholders need to be taken into account for successful adoption smart grid technologies [11,12]. The challenge is to provide high value for all stakeholders. Important stakeholders in the building service sector are included in figure 2.

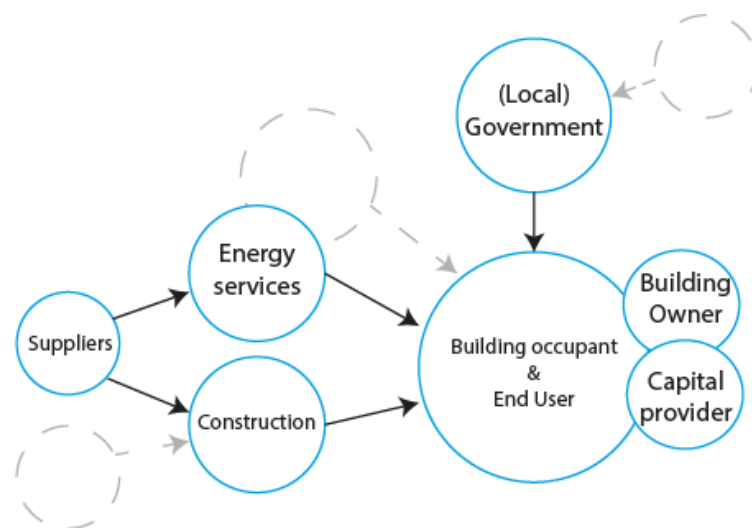

Figure 2: Representation of stakeholders in the building energy services sector.

2.1.1 Needs in the built environment

People spend over 80% of their time inside buildings [13]. For end-users residing in the built environment, comfort is one of the primary values a building should offer. Comfort is a complex aspect influenced by, for example, spatial qualities, service provision and user interaction (more details are presented in section 3.1). End-users are however not the only stakeholders on the building premises.

For a business operating from an office building, energy costs ($\sim 15\text{€}/\text{m}^2\cdot\text{yr}$) are low compared to their total expenses; in stark contrast, employee costs are more significant ($\sim 210\text{€}/\text{m}^2\cdot\text{yr}$)⁽¹⁾. The efficiency of employees is therefore more important than energy costs. Building comfort

(1) Based on average energy consumption of offices [14], average salary costs for companies in the Netherlands [15] and a low office occupation (20m^2 per person).

influences working efficiency and should therefore be an important value for stakeholders in the building. Furthermore, operational efficiency and reliability are important as the building supports the core business of its occupants.

For other stakeholders in the built environment, such as building owners or capital providers, total value of ownership is one of the most important aspect since they carry financial risks. For those entities, total value of ownership is important. The known concept of total cost of ownership (TCO) considers the total cost over ownership whereas ‘total value of ownership’ (TVO) also considers qualitative aspects like contributions to image, property value and other benefits that influence the value of an investment.

An overview of stakeholder needs and an indication of the expected value perception based on expert opinions is included in figure 3. In this figure, various values that can be provided by building automation and smart grid concepts are presented horizontally. Vertically, stakeholders in the built environment and energy sectors are presented. A darker colour indicates the value is considered to be more relevant for the specific stakeholder.

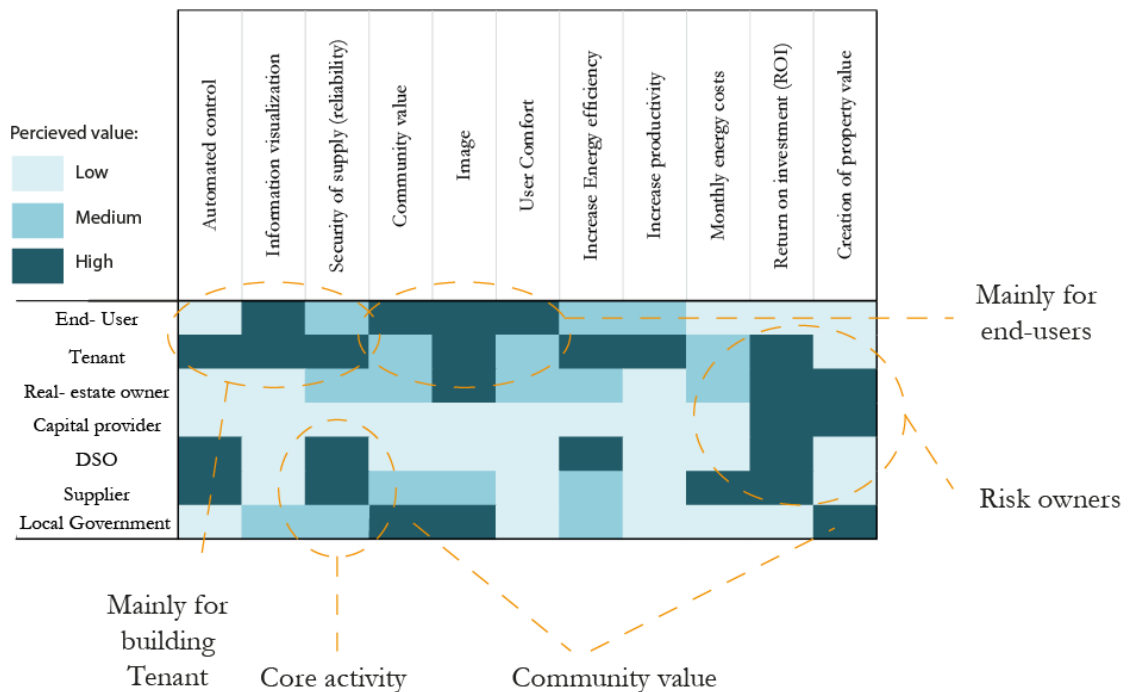

Figure 3: Value perception of different stakeholders in the office environment. The columns present potential values of smart services in and around buildings.

From the analysis of the value perceptions, it becomes clear that the risk owners, which are mainly the capital providers and asset owners, have a high regard for economical value whereas the asset users have a high regard for services. End- users value the potential benefits for their working environment, while tenants have a higher regard for values that contribute to management and cost reductions. The local government is interested in social value, area cohesion and land value. It can be concluded that there is a mismatch between value perception of the risk owners and the value perception of the users.

In order to satisfy all stakeholder needs, services that can attribute to the needs of the energy system, financial risk owners, tenants and end- users is required. This can be reached by providing services to users while reducing risks for capital providers and assets owners.

2.1.2 Needs in the energy sector

The energy sector is challenged with guaranteeing a reliable supply, and keeping energy affordable [16]. Traditionally, buildings are just energy consuming ‘loads’ for the energy sector. The electricity supply infrastructure is designed to be a one- way system that is centrally controlled depending on the demand.

The traditional organization of the power system leads to challenges in the future. Ongoing electrification is expected to contribute to an increase in the demand [8,9]. Increase in demand and integration of decentralized, intermittent generation challenges the operation of the power system with potential congestion and imbalances leading to high costs and possibly to instability. These are not challenges for the long term future; problems already occur in areas with high PV penetration [17] and peaks in wind production are, for example, leading to negative prices [18].

Flexibility on the demand side can contribute to ensure reliable operation at acceptable costs. Using flexibility on the demand side, consumption can be reduced when supply is low or when there is congestion in the grid. This way, the demand side contributes to balance and capacity management. This may reduce operational costs and the need for investments in grid reinforcements.

2.2 The electricity market

An understanding of the electricity system is required to be able to provide in the needs for the electricity system. The traditional physical supply chain consist of production, transmission, distribution, supply and consumption (see figure 4). The energy market in the Netherlands is liberalized and market roles (e.g. transport and supply) are unbundled. Since the availability of the energy system is of key importance for the economy, the market is regulated.

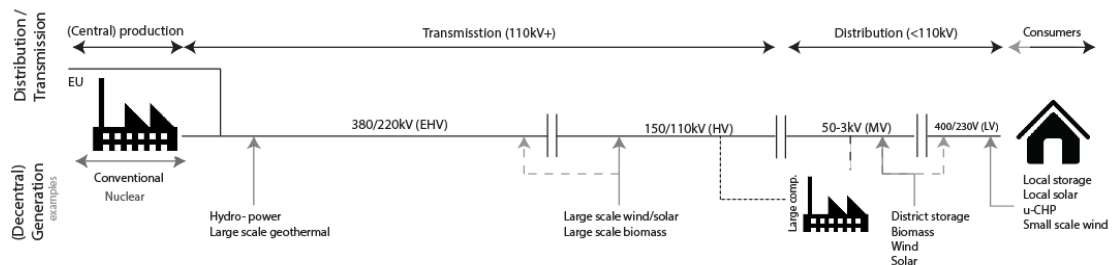

Figure 4: Schematic overview of electricity system including decentralized production facilities.

2.2.1 Operation of the electrical power system

Since storing electricity is not economical, demand and supply need to be balanced at all times. Imbalances can be caused by differences in output compared to set-points of thermal plants, by differences in consumption patterns and by output from intermittent energy sources such as wind- and solar generators.

Tennet acts as transmission system operator (TSO) and is the authorized entity to market balancing services for maintaining balance in the area for which it is responsible, i.e. the Netherlands. Three balancing mechanisms ensure reliable operation of the power system: primary-, secondary- and tertiary control. Primary control is fast responding control of generation units which is automatically activated to stabilize frequency after a contingency event. The large, interconnected power system remains in balance through this primary frequency control. For energy producers it is mandatory to maintaining primary reserve capabilities.

Secondary control (regulating reserve), is governed by the TSO and is activated by load frequency control when there are imbalances. Tertiary systems for reserve and emergency power are activated manually and are activated for longer periods. Secondary- and tertiary control actions are also called frequency restoration reserves [19]. Apart from the balance control, load shedding schemes can be applied during times of grid congestion.

Program responsible market parties (PRP) have the responsibility to maintain a balance in demand and supply for each settlement period. The settlement period, called a program time unit (PTU), is 15 minutes. Each day is thus divided in 96 PTU's. During operation, the TSO monitors system balance in real-time and adjusts for imbalances. Therefore, the TSO contracts regulating reserves on an imbalance market, which is governed by the TSO. Market parties can place bids for regulating and/or reserve capacity on the imbalance market, to contribute to system balancing. The PRP's use information from TSO to contribute to balancing by solving their own imbalance, accepting adjustments from TSO on the imbalance market or creating an internal imbalance in the opposite direction of the system imbalance (which is also rewarded) [19]. An example of the imbalance market clearing is provided in figure 6.

After clearing of the markets, PRP's send an e-program, containing the consumption/generation planning for the next day per PTU, to the TSO. During operation, PRP's are required to follow the planning. Costs for correcting actions are retrieved by penalties for the parties that cause the imbalances. The realized value is calculated after each control period.

The economic operation of the grid is separated from the technical operation of the grid. Energy producers and suppliers, which are not necessarily PRP's, can trade electricity on the future and spot markets [20]. Futures are traded on the ENDEX market. Prices for the short term are settled on the day-ahead spot market. An example of the clearing of the spot market (the APX) is provided in figure 7.

The economic operation of the electricity infrastructure is included in figure 5 (based on [21]). Besides trading on the market or purchasing energy at suppliers, large consumers can buy directly with producers using 'over the counter' (OTC) contracts.

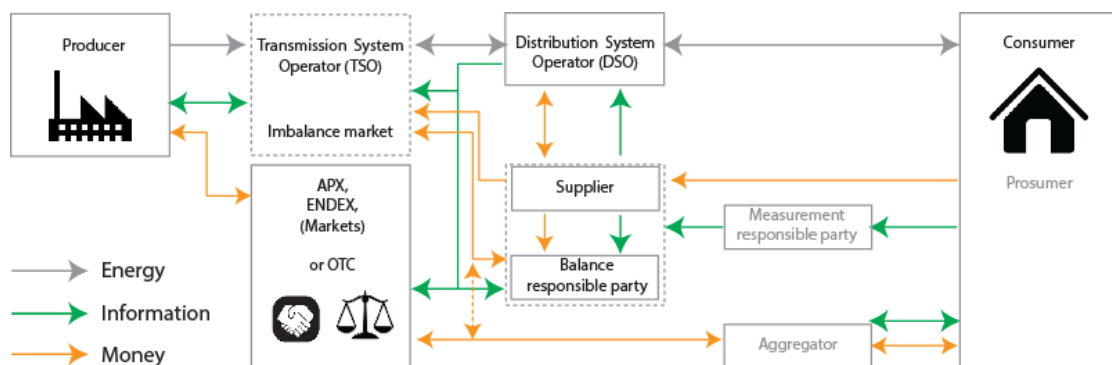

Figure 5: Technical and economic operation of the Dutch power system. New market roles are included in grey.

While the TSO is responsible for bulk transmission and system control, electricity distribution is managed by the distribution service operator (DSO). The DSO operates the distribution network and provides the connection for electricity suppliers and producers. A service fee is charged to users of the network.

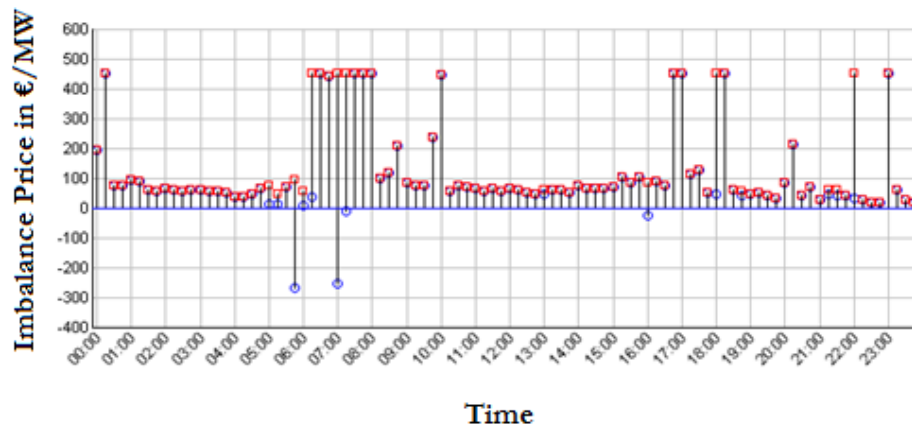

Figure 6: Example of the Dutch imbalance market prices (Sunday, 15-12-2013) [22].

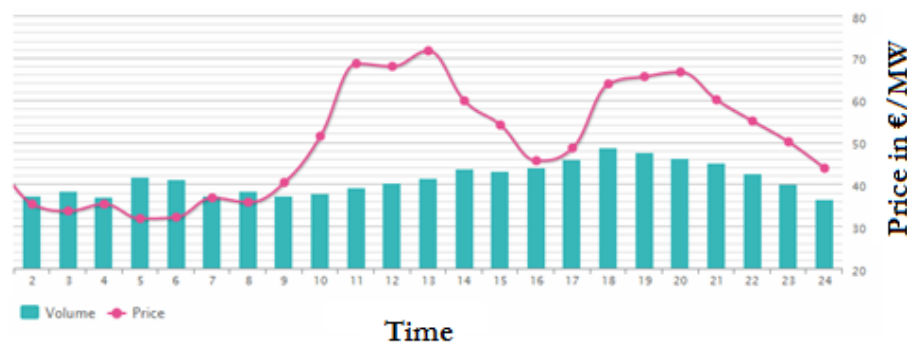

Figure 7: Example of spot market settlement on the Dutch APX market (Sunday, 15-12-2013) [20].

2.2.2 Electricity market prices

The prices on the day-ahead spot markets vary each hour (4 PTU's), depending on the demand/ supply on the market. Similar to the financial or resource markets, forward contracts are available on the future market (ENDEX) while short term provisions are available on the spot market (APX) [19,20].

Prices on the ENDEX are generally more stable compared to the sport market (APX) prices. Trading on the wholesale energy markets requires a subscription with the TSO and implies balance responsibility. Trading via a broker is also possible. When trading via a broker, a fee of 0.5-2€/MWh is charged to cover the trade risks. For 2011, the average spot-market price (APX) was 0.052€/kWh (0.07€/kWh peak, 0.04€/kWh off peak, also see figure 6). Extensive strategies for optimal energy trade can be pursued by trading futures and/or anticipating to the imbalance markets. Often, base load is contracted bilaterally or on the future market while the variable consumption is purchased on the APX market.

It is expected that the markets will become more volatile as the share of intermitted generators increases and the electrification continues. The average price is however expected to reduce [23]. The imbalance markets will become more important as volatility increases. Responding to imbalance (by adjusting consumption or generation) can be profitable while causing imbalance can be costly as the prices on the imbalance market range from 0.1 €/kWh to 0.4 €/kWh (see figure 7).

The Dutch market is coupled to the French, Belgian, English, German, Luxembourgian and Scandinavian markets [23]. Supply and demand in those areas influences Dutch energy prices. This means that peaks in German PV and wind production are felt in the Dutch market as well [17,23]. Even when the adoption of sustainable energy in the Netherlands would be

slower than expected, the influence of countries with considerable shares of intermittent generation such as Germany (Wind and PV) and Denmark (Wind) leads to increased market volatility in the Netherlands.

Prices for end users differ from the market prices and do usually not vary during the day (except for day/night tariffs). The costs for end consumers consists of energy supply costs, network costs and taxes (~50%). Large consumers also pay for power consumption in form of a contracted capacity (€/kW) and a separate charge for the actual peak they create. Energy costs for consumers have steadily increased over the past decades [15]. In 2013, energy prices have fallen slightly due to low interest rates, which reduced investment costs for DSO's, who were then forced to reduce their tariffs for the coming years [24]. Future end- user energy prices depend on government policy, network costs, market volatility and resource prices.

2.3.3 Legislation changes

In most EU countries, the energy market is liberalized based on EU directives. The market is heavily regulated to ensure high reliability of this complex technical system. The most important legislation for the energy sector in the Netherlands is called 'Elektriciteitswet 1998' (electricity law 1998) [25]. The law regulates both energy supply and the infrastructure.

The Dutch law is constantly evolving to facilitate the energy transition; these changes offer opportunities for energy service provision. The most relevant changes for 'buildings which are active on the energy markets' are the introduction of the 'direct line' and 'unlimited netting' [25].

The unlimited netting act influences energy consumers that have generation facilities. When injecting on-site generated energy into the grid, consumers have the ability to deduct the amount of injected energy from the energy consumption (netting). With the new legislation, it becomes more economically attractive to install larger generation systems in buildings.

The direct line describes a direct connection between the generator and the consumer. With a direct line an owner of PV may, for instance, feed energy to tenants in an apartment building without involvement of the DSO. Distribution costs and energy tax can be avoided in that case. The combination of the 'direct line' and 'unlimited netting' offer possibilities for decentralized energy initiatives.

2.2.4 New market roles

With the adoption of the smart grid paradigm, new market roles become available. On the demand side, the customer takes on an active role as the he starts producing energy and/or has the ability to respond to market signals (e.g. demand response). The consumer thus becomes a 'prosumer' [21,23].

To create value on the energy market, the aggregation of small-scale decentralized resources like PV panels and demand response capabilities is possible [26]. Using a portfolio of such generators/loads, the aggregator can engage in trade and manage the resources in name of the owners. The 'aggregator' and 'prosumers' roles are added to the roles presented in figure 5.

2.3 Economical value of flexibility in the electricity system

There are multiple ways to use flexibility in consumption/production in buildings. The economical value of flexibility is, depending on the application, determined by the markets. Flexible energy consumption of processes in office buildings can provide value for the energy sector by contributing to balancing supply and demand, and by contributing to congestion management. This translates to economical value on the energy markets. From the building perspective, contracted power might be reduced and energy can be purchased at optimal times.

With optimal purchase schemes in which energy is bought at optimal moments, the market volatility is used to gain a financial advantage (see figure 6). From a comparison of on- and off-peak prices on the spot markets, it can be concluded that an advantage of 0.04€/kWh can be reached [20].

When flexibility is used to balance a portfolio, the portfolio imbalance and deviation from the e-program can be reduced. Flexibility can be offered to a PRP through contracting. A temporary reduction of demand can be seen as negative production and is as such equally valuable as additional generation capacity. The value of providing reserve power on the imbalance market is approximately 0.05 €/kW. This number is based on the analysis of assumed imbalances and imbalance clearance data from Tennet [22]. The estimation is supported by analyses found in literature [27].

Finally, flexibility can contribute to congestion management and the reduction of peak demand of buildings. Large consumers pay a tariff for the distribution grid depending on the contracted capacity and on the peak that is actually created. Flexibility can be used to reduce this peak which leads to lower costs for peak power. The value is between 11 and 18 €/kW depending on the contract and size of the connection (based on existing contracts).

2.4 The building services sector

The building services sector provides building systems and services such as maintenance and energy management. The services aim to provide comfort and energy efficient operation of the building installations. The crisis in the construction sector has led to a decrease in investments, difficulties in attracting capital and increased demands for performance in terms of energy efficiency and comfort. Since this performance needs to be guaranteed, energy management and monitoring is becoming more important for the sector.

The integration of services like continuous commissioning, monitoring and energy management is a response to the market needs. Flexibility in consumption can contribute to these services by assuring effective and efficient operation of buildings. The former is based on providing energy where and when it is needed while the latter is based on reducing energy consumption when it is not needed and the use of predictive control schemes for efficiency purposes.

2.4.1 Energy service models

New models are developed to meet new market requirements. Upcoming service models include the 'energy service company' (ESCO) and the public private partnership (PPP).

In ESCO's, the benefits of refurbishment leading to reduction in energy costs is shared among stakeholders, while limited or no investment from the end-user is needed [28]. This gives an incentive for ESCO's to provide high performance. In PPP's capital is partly brought in by the authorities, and partly by private companies. Long term service provision like commissioning and energy supply in the public domain [29].

Integration of smart grid services, like demand side management, can be a diversification of the activities already offered in ESCO and PPP structures.

2.4.2 Technological development of building management systems

Building management systems (BMS) need to optimize energy production, consumption and storage for the client in relation to comfort, costs and other potential optimization targets. Most buildings constructed after 2000 have automated, digital control and are easily adaptable for communication and control from a remote site [30].

BMS are becoming more advanced as more sensing and computational power is becoming available [31]. Local optimizations that include generation and load prediction, comfort optimization and costs optimizations are at the forefront of developments. BMS's move from

an ‘automated’ to an ‘advanced’ type of control, which includes prediction and agent-based optimization strategies [31,32]. The next step will involve integrated control, which enables interaction with the environment and exchange of services with the smart grid.

2.4.3 Integration of smart grid concepts in building management systems

With the development of smart grids, the integration of smart grid technology in the BMS becomes relevant. Demand side management (DSM) applications can be integrated with the BMS to contribute to overall grid balancing while operating the building efficiently. DSM strategies include multi-agent based strategies [33-38] but also other strategies based on predictive control [39-42], or game theory [43]. For demand and supply management, PowerMatcher [8, 44-46] is one of the prominent control concepts.

PowerMatcher is a distributed energy system architecture and communication protocol, which facilitates implementation of standardized, scalable smart grids, that can include both conventional and renewable energy sources. PowerMatcher technology optimizes the potential for aggregated individual electricity producing and consuming devices to adjust their operation in order to increase the overall match between (electrical) energy production and consumption [8]. One of the alternatives for the PowerMatcher is the Intelligator which is priority- instead of market based [47-49]. Further details are included in section 3.3.

Development of smart grid applications for energy management is not limited to BMS and DSM. Aggregation of resources in so called ‘virtual power plants’ (VPP) is given much attention in research, DSM control concepts could be used to manage such an aggregation effectively, providing opportunities to fulfil the envisioned aggregator role [26, 50-53]. Concepts such as PowerMatcher and Intelligator can also be used in VPP operation.

2.5 Smart grid projects

The technical needs and economic opportunities result in numerous smart grid related projects that are being developed. Currently, many projects are in demonstration phases. Projects focus on grid operation, balancing supply and demand and integration of ICT. Given the changing market roles, projects also experiment with business concepts [21].

On global level, there is a large effort to develop smart grids. Organizations like the International Energy Agency, European technology platforms, and US Department of Energy have extensive smart grid related programs. In Europe, smart grid research is included in the Horizon 2020 programme [54]. Also, China, India, Brazil, Australia and Japan invest heavily in smart grid technology and research [55]. In this report, the focus is on the domestic (Dutch) market. Therefore, the overview of projects will focus on initiatives in the Netherlands.

In the Netherlands, energy is one of the ‘top sectors’, meaning the energy sector is identified as one of the seven main pillars/ growth opportunities for the Dutch economy. The top sector policy intends to focus research and development efforts by stimulating knowledge exchange, innovation and investments [56]. Figure 8 includes a timeline as developed by the top sector ‘energy’ for smart grid development [57].



Figure 8: Smart grid development timeline [57]. Currently service demonstration projects and large scale demonstration projects are conducted.

Subsidies are available for project development and innovation (IPIN) [58]. Twelve projects received IPIN subsidy in 2012. Subsidized projects include; the ‘Smart Energy Collective’ [10], ‘Intelligent heating grid Delft [59], Couperus [60], Modienet [61], PowerMatching City [46], ‘Neighborhood of tomorrow’ [62], Evander [56], ‘Self-sufficient Heijplaat’ [56], Cloud Power Texel [63], ‘Intelligent nets; Zeewolde energy transition’ [56], ‘Your energy moment [64] and ‘DC-net in the Haarlemmermeer’ [61].

One of the main focus areas of smart grid development is demand and supply balancing. PowerMatching City was the first ‘live’ project in Europe on balancing supply and demand in a smart grid environment. Field tests using PowerMatcher technology have yielded good results on load balancing and peak reduction [8, 44-46]. Based on the experience and results from the initial demonstration, a new project based on the PowerMatching City is granted, focussing on the end-user and up scaling. In the Couperus project, the PowerMatcher concept will be implemented in 300 homes in The Hague [60].

Another example of a large project that aims to gain experience with technical, economical and social options for creating flexibility and increased sustainability is ‘Your Energy Moment’ (YEM) [64]. As part of YEM, 250 houses in Zwolle and Breda will be integrated in a smart grid. The project presented in this work differs from most demonstration projects since it focusses on offices specifically.

Besides programs on national level, various regional initiatives exist [57]. ‘Energy Valley’ aims, for instance, to exchange knowledge and develop demonstration project in the north of the Netherlands. Furthermore, there are examples of international cooperation. The e-harbours project, for example, aims to develop smart grids in European harbours including supply and demand matching (Antwerp), E- monitoring and demand side management (Hamburg) and insight in emissions and waste (Uddevalla) [65]. Other participants include Amsterdam and Zaanstad in the Netherlands.

For the future, more demonstration projects are expected. New projects that are under development include ‘Energie van de Veenkolonieën’ (energy from the peat colonies’) which aims to integrate 400 houses in a living lab [66] and ‘Meppel energie’ (Meppel energy) which will feature the first commercial hybrid heat network with 3400 homes [67].

2.6 Required technological and process innovation

Although there are many smart grid related developments, there are still challenges remaining. This paragraph introduces some of the complexities in smart grid design and some of the remaining challenges.

Smart grid design is a complex task given the stakeholder relationships in the power system and the built environment (see figure 2). Cooperation is needed to be able to cope with the

complexity of smart grid design [11,12]. In order to meet the design challenges, reference architectures for service provision and system development have been proposed. The M490 scheme is proposed by Siemens [68] to be used as framework for smart grid design. No generally accepted framework containing business development, system interfacing and system development does however exist. This leads to uncertainties in project development and implementation of smart grid technologies. An important challenge remains the enabling the right framework or system design for flexible control to provide smart grid services in office buildings.

While the M490 model focuses on the design phase, the USEF (universal smart energy framework) specifically considers the market (business layer in M490). The USEF framework is a part of the SEC project and aims to describe the new market roles and types of service provision [10]. One of the challenges, is finding out what the role companies active in the building services sector can take in this framework (technically and commercially).

In order to be able to provide flexibility services, and develop feasible business cases, processes for determining the flexibility ‘a-priori’ and frameworks that enable flexible control are needed. In an office environment, smart grid services need to be integrated in the BMS. In the remainder of this report a technological framework for integration flexible control in office buildings is introduced.

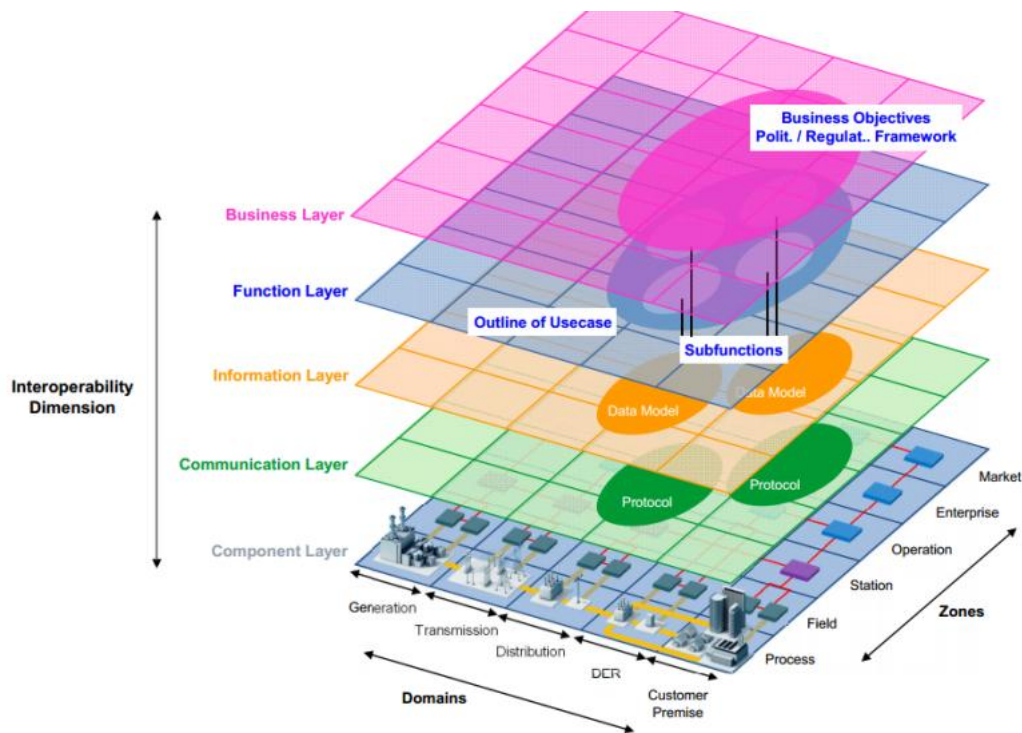

Figure 9: M490 reference model for smart grid design and integration [68].

Chapter 3: Integration of smart grid services in office buildings

The technological framework required to provide flexibility services is introduced in this chapter. With priority based control, flexibility in energy consumption/ production of processes can be enabled while respecting the needs of all stakeholders.

3.1 Providing and measuring comfort

The basic function of a building is to provide shelter and safety. An office building generally supports the company's primary goals. The building should therefore contribute to personnel efficiency by offering a comfortable working environment. Comfort is a complex quality of a building; many psychological and physical processes may affect the perception of comfort. Automatic operation of buildings systems does not automatically lead to an optimal comfort situation [69]. The user should always be able to have a certain level of control over its own environment. Therefore, it is important that the user can influence the local climate, and that processes can react to the user needs. This requires a proactive system which anticipates events and adjusts to its environment.

The complexity of the environment and aspects that influence comfort do however lead to challenges. Efficient and comfortable operation of a building leads, for example, to multi-objective optimization problems. The ultimate goal for building comfort control is to provide a comfortable environment for all individuals efficiently and effectively. Efforts to integrate both optimal energy operation and comfort are based on multi-agent approaches [70] and predictive control schemes [36,39,40]. In the current study, the focus is on the economical operation, while maintaining comfort for the end-user. Therefore, measures for comfort are needed so control bandwidths for comfortable operation can be developed.

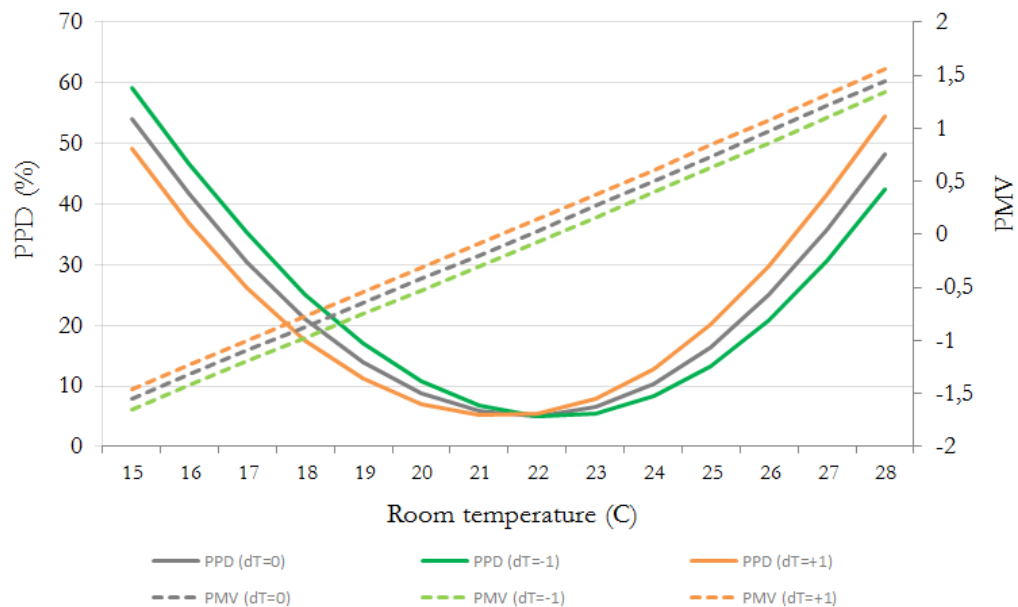

Figure 10: Example of PMV and PPD curves.

Several measures for the comfort in the indoor environment are used in the building services industry. The 'predicted mean vote' (PMV) and 'percentage of people dissatisfied' (PPD) are important measures for thermal comfort that are based on models, which are calibrated using empirical research. The experienced indoor climate is not only depending on air temperature: radiant temperature, air velocity and metabolic rates have a large effect on the experience of

climatic comfort [69]. An example of the PMV and PPD values as function of room and radiant temperatures is included in figure 10. In this figure, three cases are included. One case in which room and radiant temperatures are the same, a case with lower radiant temperature and a case with higher radiant temperature (ΔT of -1 and ΔT of +1 respectively). Improved occupant comfort models are being developed since the PMV and PPD models fail to differentiate subpopulations and important driving mechanisms for thermal comfort [69,71,72]. The PMV and PPD measures can however, be used to include the expected effect on user comfort in the flexibility assessment process.

Apart from climate comfort, there are many more aspects that influence the overall comfort experience, such as lighting conditions, spatial quality and service availability. These aspects can be represented by comfort parameters, leading to an ‘overall comfort’ which can be included in the decision making functions of building management systems. In general, optimization problems can use comfort requirements as constrains (e.g. in [36,37]). A ‘total comfort measure’ can be constructed from individual comfort components (like climate and service availability) and meet a minimum requirement per room (as suggested in [70]). This is particularly useful for non- climate related process that provide flexibility.

To be able to offer flexibility while providing user comfort, a comfort bandwidth will be used. Hence, a specific set of ‘comfortable’ states is assumed. Later on, more advanced control schemes can be used which for instance include adaptive comfort [69]. The user can control the set-points of the system, and the system will try to stay within a bandwidth around this set- point. While postponing energy consumption can have a negative effect on user comfort, flexible operation of building systems can also contribute to user comfort as heating/cooling can, for example, anticipate user behaviour [70], and the required sensor networks contribute to optimal control and user feedback [69].

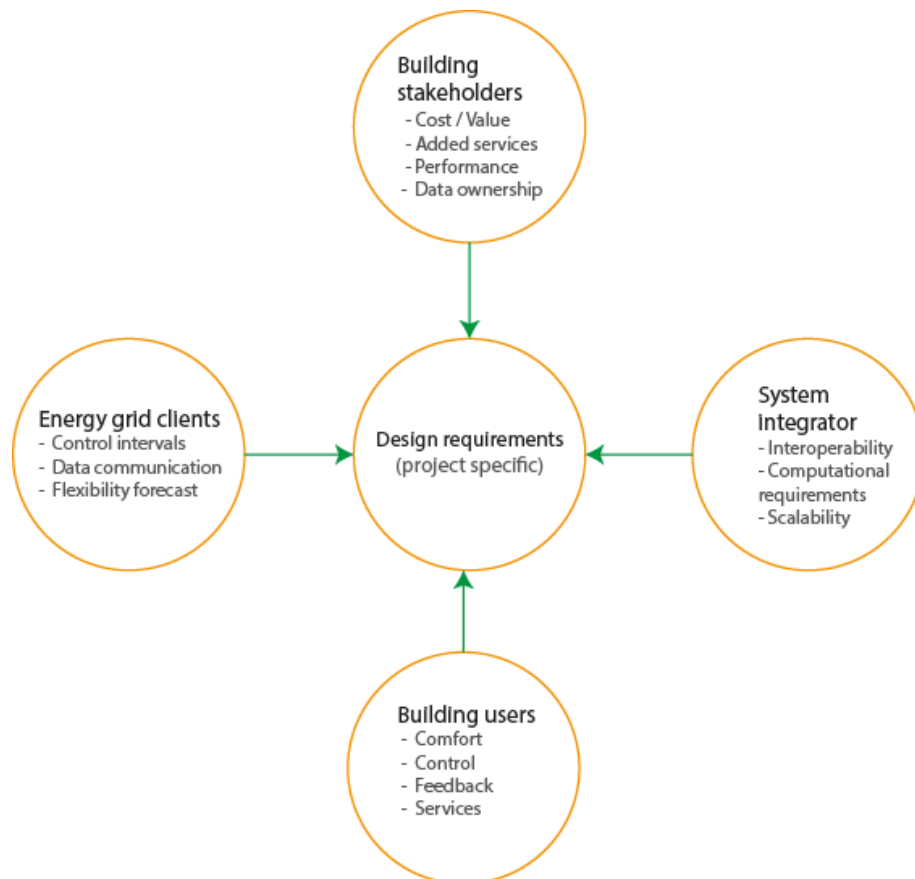

Figure 11: Design elements from various stakeholders that influence design requirements.

3.2 Design elements

Design elements form the basis for requirements which depend on the specific application of the flexibility services (see figure 11). For the smart grid, integration issues include planning and legal frameworks issues [12]. Communication with stakeholders at the side of the power system therefore important for development of demand side management (DSM) applications. For smart grid design in general, dimensional complexity, technological complexity and stakeholder complexity result in challenges for the design [11]. Based on analysis of problem complexity and design methodology, P.F. Ribeiro et. al. [11] suggest several tools for ‘planning and design of smart grids’ based on philosophical considerations. Here, an effort is made to integrate the technological dimensions in the design framework. Design elements are based on current requirements and results of previous studies [8,11,12]. Arithmetic- (quantities), analytical- (logic, distinction), formative- (control and freedom), social- (interaction with systems and users), economical-, psychological- (human interaction), juridical- and trust dimensions are included.

User comfort Dimensions: Social Psychic Formative	The level of service/comfort should be considered when offering flexibility; postponing energy consumption should not lead to a low comfort level or compromise the building’s basic functions. The user should have a level of control over the environment.
Efficiency Dimensions: Economics Analytical	Efficient operation means getting maximum result with minimum effort (i.e. minimum energy consumption). Effective operation means spending your energy on the tasks that provide maximum benefit. Effective economical, and efficient energetic operation can be conflicting; a control system should be able to make informed decisions on effective operation and efficiency.
Data ownership Dimensions: Jurisdiction Trust	Data ownership is a major point of discussion when considering the future of the energy infrastructure and service provision. Advanced services can include exchange of signals from which sensitive information could be filtered. Recent discussions on data ownership, for instance with respect to the smart meter, has led to new European legislations [73]. Considering the ever increasing interconnectivity of society and economy, data ownership is expected to be an important element in future service provision. Data ownership can be managed by aggregation of data in which only the required information is passed on and detailed information about individual processes/entities is lost [8].
Interoperability Dimensions: Formative Arithmetic	There are many stakeholders affecting building operation. As buildings have a long lifetime, changes in building function and systems should be expected. Also, different services can use the same sensory and communication infrastructures when interoperability (and ‘openness’) is included in the initial system design [8]. This reduces the cost of refurbishments and enables expansion of services without the requirement to redesign the control infrastructure.
Scalability Dimensions: Formative Arithmetic	A building may contain hundreds of zones/ rooms and thousands of processes. Furthermore, when considering portfolio optimization, the solution may need to communicate and cooperate with other buildings. The control solution should be scalable, without an exponential increase in computational requirements.

Market integration

Dimensions:
Arithmetic
Social

The specific application of the design requires exchange of information with the electricity markets. This requirement makes this implementation different from optimal solutions that focus on efficiency and comfort within the building [70, 32] and makes it more similar to DSM mechanisms [41,42].

3.3 Evaluating flexibility

Being able to express the flexibility ‘a priori’ is important in project acquisition and design stages as the potential economical value and risks need to be clear. A flexibility analysis can be performed to get a sense of the available flexibility, potential of different flexibility sources and the main sensitivities of the flexibility. A standardized method for flexibility analysis has been developed and depicted in figure 12.

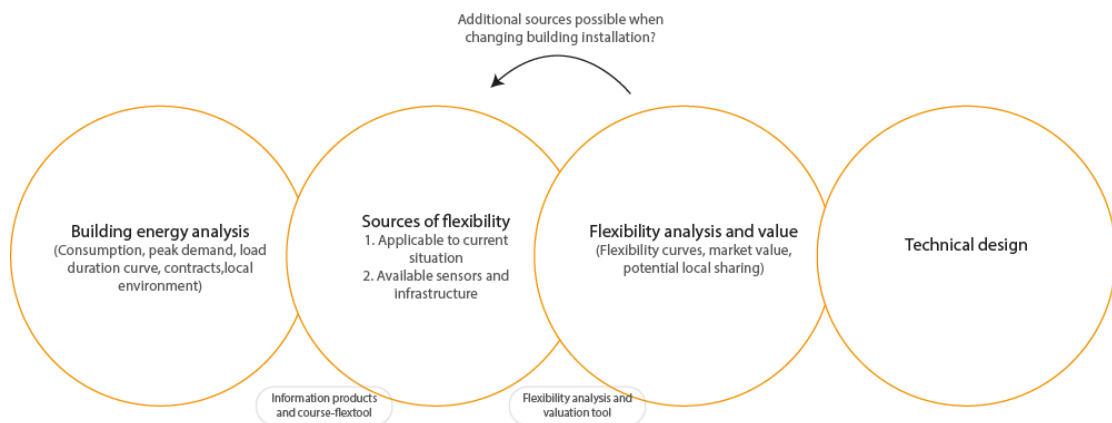

Figure 12: Process for evaluating building flexibility.

3.3.1 Sources of flexibility

Processes of which the energy consumption can be postponed without compromising the basic functions can provide flexibility. In buildings, several processes can become ‘sources of flexibility’ when either a buffer is present, or processes are shiftable. The building thermal mass can be used as intrinsic buffer, a battery can store electric energy, and some processes can be temporarily interrupted. Figure 13 (next page) presents an overview of flexibility sources on different levels in the building [74].

The potential energy storage (kWh) and power flexibility (kW) differ per process. General values for available storage capacity for various sources are provided in table 1 (next page). The values of table 1 are based on general indicators of different technologies/ materials of which the average is presented. The amount of available flexibility is sensitive to form factors, user profiles, installations. Therefore, the available flexibility cannot be fully characterized without a detailed case study.

There is a difference between the potential- and realistic (usable) flexibility in a building. The amount of flexibility that can be used depends on desired comfort levels and the building’s sensor and actuator network. High resolution of measurements improves controllability and predictability of flexibility.

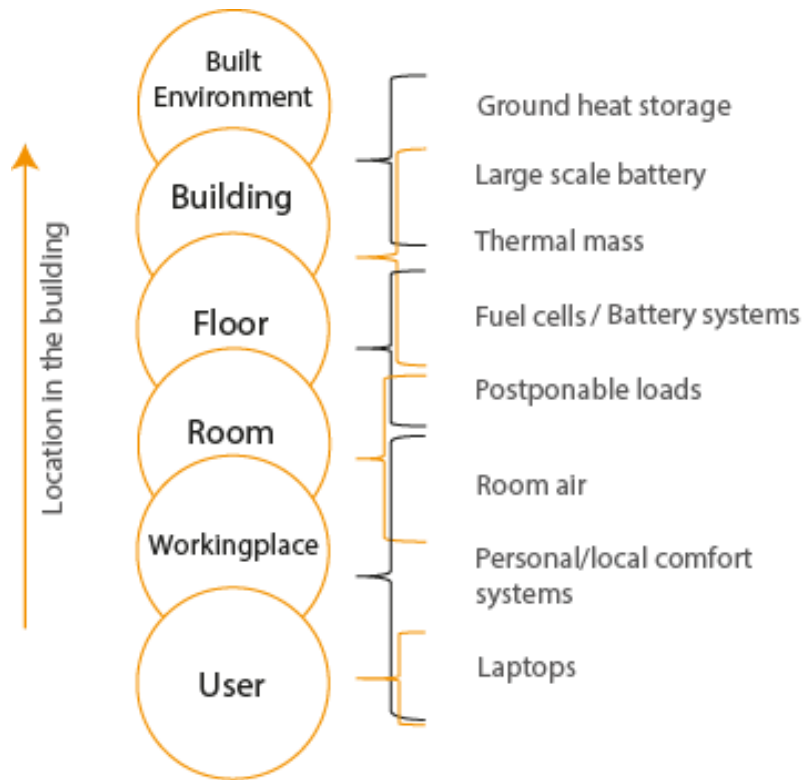

Figure 13: Sources of flexibility depending in the location on the building premises, based on [74].

Table 1: Potential sources of flexibility in office buildings

Type of flexibility	Buffer	Energy density	Power	Time constant (τ)
Electric buffering	Battery	176 kWh/m ³	Order of W to MW	1 hour to 10 hours
Thermal buffering	Building thermal mass	0.4 kWh/m ³ .°C	3- 10W/m ²	12 hours to several days
	Room space (air)	0.00027 kWh/m ³ .°C	13-26W/m ²	6-10 minutes
	Physical buffer	1,16 kWh/m ³ . °C (water)	0.001-10MW	Depending on power
	Ground storage	30-40 kWh/m ³	Heat exchanger dependent	
Shiftable loads (batch process or other types of buffering)	Ventilation	-	0,5-1,5 W/m ²	1 hour
	Irrigation/ supply of flow commodities	-	Order of kW	Batch
	Waste treatment	-	Order of kW	Batch

3.3.2 Expressing flexibility

The amount of flexibility is characterized by the power (P , in Watts) and the horizon over which the flexibility is available (t in minutes). Flexibility can be seen as a resource that can be consumed. After a time t , energy has to be consumed to guarantee comfort, and the flexibility is depleted. The resource can be expressed in a single quantity (relation) that contains power, duration and depletion information (kWh over time) [75]. A time constant (τ in seconds) can be useful to characterize the system inertia. The time constant τ is defined as the time a system takes to reach 63.2% of its final value in response to a step in the input signal. Heating thermal mass takes, for instance, a long time (high τ) which indicates that it takes time before the mass heats up and affects the surrounding environment while restoration of the flexibility resource is slow. Time constants are included in table 1.

3.3.3 Analysis of the available flexibility

Processes are modelled to be able to provide an expectation of the required energy consumption of the process. This is required to provide insight in the flexibility that a process offers. Simulations are performed for relevant time horizons, which can range from minutes to multiple days, to determine the minimum amount of energy needed to guarantee comfort at the lower bandwidth. A second simulation is performed to find the maximum energy that can be consumed. A third simulation can be performed for the ‘business as usual’ case to express flexibility as function of normal energy demand.

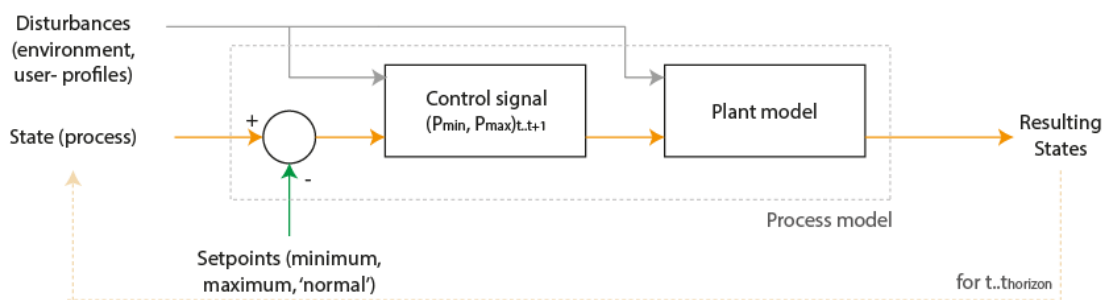

Figure 14: Schematic representation of process models. Process models are used to generate minimum and maximum energy consumption for the process for the relevant time horizon.

There are different modelling approaches that can be used in such simulations. The available information, computational requirements, resolution and information determine how a model is designed. For the current study, the models are data driven; generating state forecasts based on historical values and sensor input. Efforts are made to keep computational requirements low, which benefits scalability. For each process that provides flexibility, a ‘process model’ is developed.

Process models (see figure 14) have been developed for room temperature control, electric vehicle charging and sensible storage buffers. A general description of the models is included in table 2. Further details are included in appendix B.

The results of the simulations can be expressed in a single quantity (relation) to provide insight in the available flexibility resource. Figure 15 includes such a *flexibility graph*, which represents the ‘flexibility space’ [75]. From the graph, the available flexibility at each moment can be obtained i.e. how long consumption can be postponed or how long it can be put forward. The flexibility graphs for different processes can be summed to provide the overall flexibility of a zone, building or portfolio.

Table 2: General description of available process models. The table includes the required sensors and actuators for physical implementation.

Process	Modelling approach	Model evaluates	Minimum sensors needed	Actuated through
Room temperature control	Quasi-static room climate simulation based on heat balance	Thermal mass, heating/cooling, ventilation, solar- and internal gains	Temperature and set-points (thermostat)	Heating/cooling set-point adjustment
Electric vehicles	Charging models	Battery size, charging power, state of charge, user scenarios	state of charge, expected time of leaving	Electric vehicle charging point
Heat pump with buffer	Energy balance based on building demand and supply installation	Building demand, heat pump, heat losses from vessel, water temperature	Buffer temperature, heat pump energy consumption, flow meters (distribution)	Buffer control valves or heat pump control

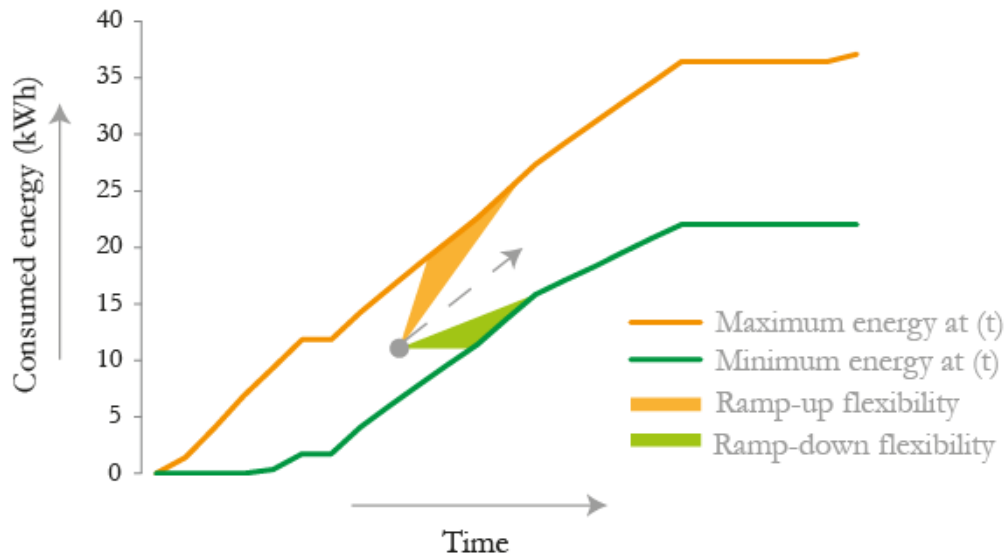

Figure 15: Principle representation of flexibility forecast in a graph, based on [8, 75]

3.4 Concepts for enabling flexibility

From the analysis of flexibility, the potential resource availability can be estimated. The control concept to enable flexible control of building processes is introduced in this paragraph. The control concept should respect the design elements introduced in section 3.2, include comfort aspects and be able to respond to market signals.

3.4.1 The PowerMatcher principle

Smart grid concepts that are able to control and balance many processes, and are able to respond to market signals have been described in literature. One of the leading concepts is the PowerMatcher.

The PowerMatcher is a coordination system in which intelligent agents, representing devices and appliances, trade electricity on behalf of the user (or other stakeholders) on an electronic market [8]. A large number of agents negotiate competitively, and trade resources with the purpose of optimally achieving their local goals [75]. Each device agent tries to operate the

process for which it is responsible in an economically optimal way. Agents determine what amount of energy they are willing to buy/sell for what price. This is expressed in a ‘bid’. Consumed or produced electricity is bought/ sold on the market.

For example: An agent controlling a battery may demand energy if prices are low, do nothing if prices are ‘average’, and offer energy if prices are high (meaning the agent will get a good return for the provision of the electricity). Low prices may occur on the internal market if there is low demand in other processes, while high prices can be the result of high demand and low generation.

Within a PowerMatcher cluster the agents are organized into a tree structure. The leaves of this tree are a number of local device agents and, optionally, an objective agent. The root of the tree is formed by the auctioneer agent, a unique agent that handles the price forming, i.e., the search for the equilibrium price. Device agents send their bids to the auctioneer agents. The equilibrium price is communicated back to the devices. The device agents determine the allocated power by matching their demand functions to this equilibrium price. In order to obtain scalability, concentrator agents can be added to the structure as tree nodes [44]. Concentrator agents aggregate the bids and pass them to an agent higher up in the tree. An overview of the PowerMatcher concept is included in figure 16 [44].

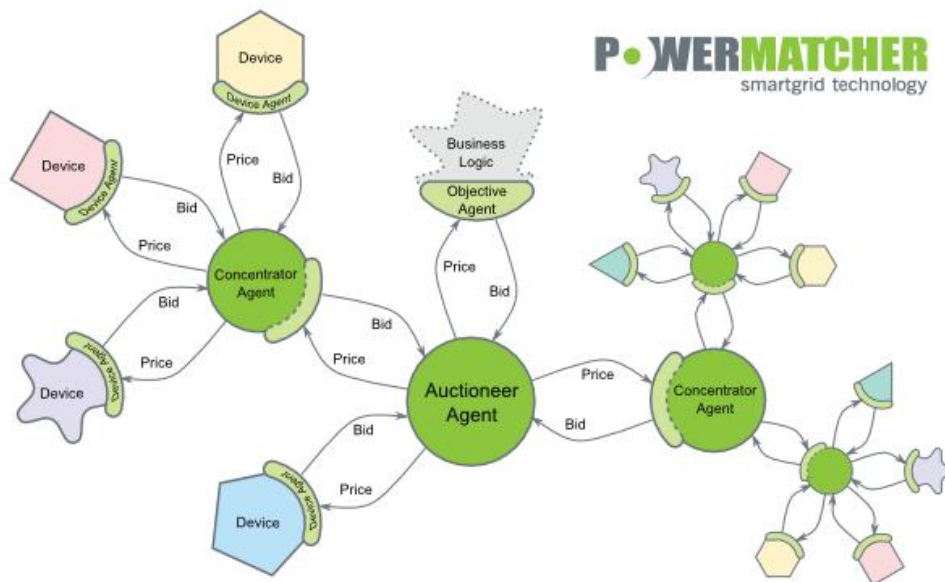

Figure 16: PowerMatcher agent cluster [44].

3.4.2 Priority based control

The flexibility enabling concept introduced here is based on the PowerMatcher principle but for the use of priority based bids. The proposed concept is therefore similar to the Intelligator concept [47-49], which is inspired by PowerMatcher. The main difference between the market based concept (PowerMatcher) and the priority based concept (Intelligator) is that the PowerMatcher assumes agents pay their actual bids, whereas the Intelligator looks at a cluster of devices as a pool of flexibility, which is only converted to money on a cluster level. The concept is integrated in the flexibility framework to provide both real-time control and analyses.

In priority based control, processes express the amount of energy that they are willing/need to consume in a ‘priority bid’, $P(priority)$. The priority bid is generated locally based on current and expected process states. The bid is then communicated to a market, which aggregates bids and matches the priority to the ‘central priority’ that depends on the priority to in- or decrease energy consumption. For the purpose of determining the central priority; a forecast of the

required energy at process level is communicated to a business entity which optimizes the consumption trajectory based on market signals and forecasts.

The local processes creating the priority bids, the aggregation and the business entity are explained in more detail in the next sections. Priority based control has the following advantages, incorporating design elements described in paragraph 3.2.

- The provision of comfort is separated from flexibility management since each process can manage comfort by itself. Advanced comfort schemes like adaptive comfort and preheating/cooling schemes can be integrated in the control framework.
- Economical efficiency can be reached by the business entity while each process can manage their own energy- efficiency.
- Aggregation of data reduces the amount of process specific information, such as local states, that is communicated. This can reduce privacy and data ownership concerns.
- Interoperability can be assured by interfacing and the use of existing communication protocols (see section 3.5).
- The expression of flexibility in priority bids, and representation in flexibility graphs makes the solution highly scalable. This scalability has been proven in similar concepts like Intelligator [47-49] and PowerMatcher [8, 44-46].

A modular design approach is used (figure 17), based on the required components needed to enable priority based control. The modular design allows for independent development of the components. The strategy can be implemented using decentralized- or central computation depending on the local infrastructure and controlled processes.

In this study, the full scheme is implemented in a simulation environment to demonstrate the process and assure that the framework can be integrated in the building. While agents can be used to represent the components of figure 17, results presented in this work are not based on a coordinated overall process. Instead, models are developed for each of the components presented in figure 17.

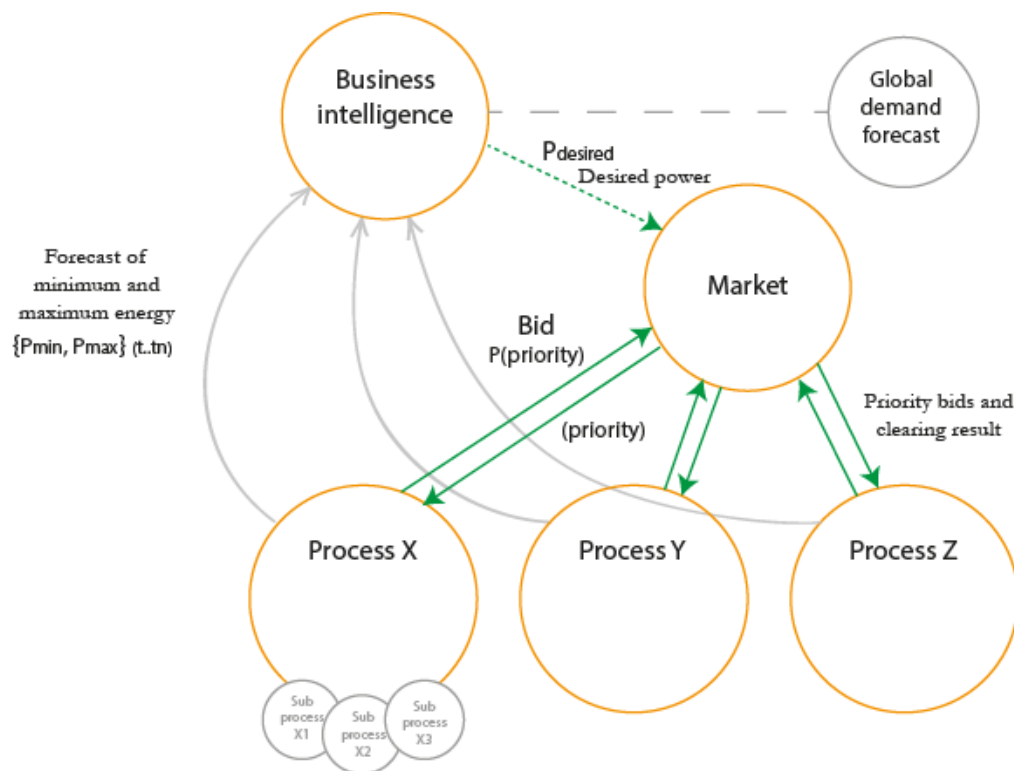

Figure 17: Modules for implementation of priority control, based [8] and [75].

3.4.3 Local process control

Local processes express the required energy on a priority scale that can be used for bidding. The way the priority bid curve is constructed can differ per process and depends on the physical capabilities of the system. Figure 18 includes examples of bid curves. The grey bid curve represents a process which has a certain minimum requirement to maintain comfort, the consumption can however be reduced. The orange bid curve represents a situation where maximum comfort is required, except when value of reducing demand is very high. The green bid curve may represent a buffer process which will charge when priority is low and discharge when priority to conserve energy is high. The effect on user comfort can thus be included in the bidding functions.

A priority bid is an instantaneous representation of the process desires. Over time, the bids change as the need to consume energy increases or decreases (depicted by the arrows in figure 18). Depending on the controllability of the process a threshold for energy consumption can be set (e.g. on/off control) or a full curve can be provided.

The local processes may be represented by an agent who can manage bidding processes and monitor room state and comfort levels. Transfer functions have been constructed to translate the local state in bid functions and the resulting matched power to a control signal.

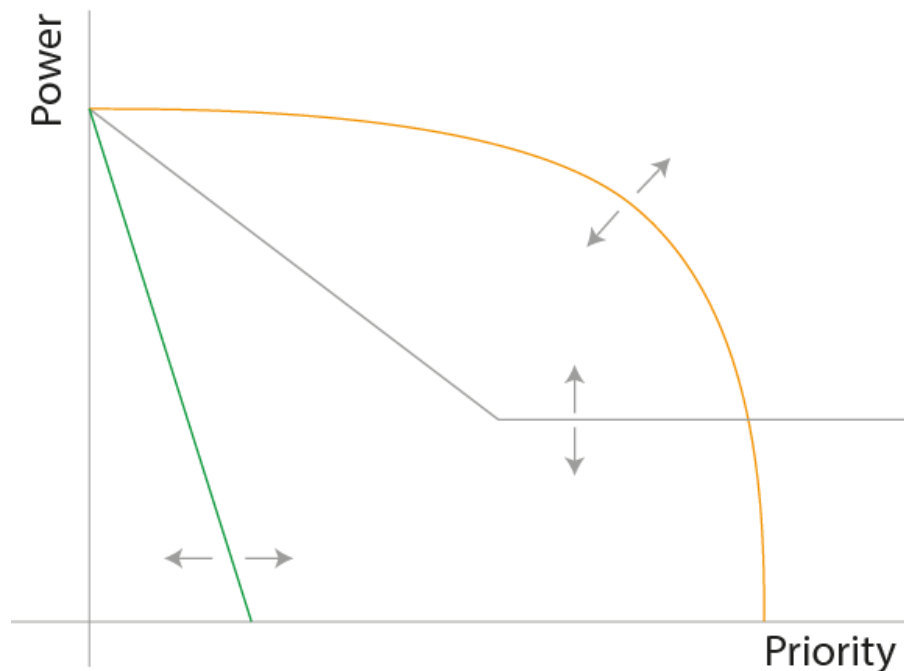

Figure 18: Bid functions, the relation between power and priority.

3.4.4 Aggregation and matching

Individual processes send bids to an aggregation unit. Power requirements are aggregated centrally to produce aggregated bid curves. The aggregated curve represents the total flexibility space available for the next control period. The aggregated curves are matched with the suggested 'optimal priority', which is provided by the business entity. The resulting priority is communicated to the individual processes that will match their priority curves with the central priority. The central priority may be updated with a different time interval than the bids. Locally it may be desirable to update the control signal every minute, to include changes in settings, disturbances etc., while the central priority may only change once every hour (4 PTU's) or in a reaction to changing forecasts.

3.4.5 Business entity (valuation)

An optimization process is used to determine the most valuable central priorities (control decisions) for the upcoming control periods. Analysis of the value of the flexibility depends on the availability of flexibility and on market opportunities. A forecast of the required energy at process level is therefore communicated to a business entity which optimizes the consumption trajectory based on market signals and forecasts. Since local desires are included in the flexibility forecast and bidding functions, the optimization problem is essentially reduced.

The optimization is based on finding the optimal route through the flexibility graph. When moving through the flexibility graph, there are costs associated with the different trajectories. Since current decisions influence future needs, it may be beneficial to choose the more expensive ‘high’ path now to be able to be more cost effective in the future. The value of a decision, expressing future benefits from current decisions, is included in the analysis. By comparing routes through the flexibility curves, an optimum ‘route of decisions’ can be determined. The optimization used for determining the value of each decision and the effects on future decisions given system limits is dynamic programming (figure 19) [76].

The effect of the ‘optimal decision’ coming from the valuation simulation is simulated at each process. This leads to a new state that is the basis for a new flexibility analysis. One might expect that the real-time control result is the same as the suggested optimum step, in particular in simulation. However, responses might differ since the required energies are quantized in the valuation process and disturbances influence the local process. A regular update of the flexibility forecast and optimization is therefore required.

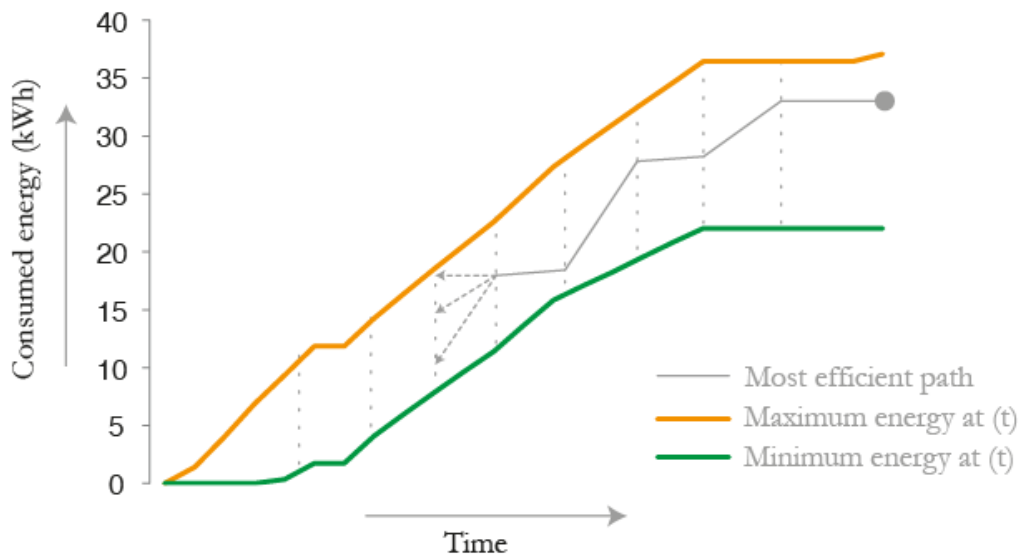

Figure 19: Determination of the optimal path through the flexibility graph using dynamic programming [75, 76]

3.4.6 Forecasting flexibility

A forecast of the available flexibility is required to find the optimal moments to use flexibility and determine the priority for processes to consume energy. Each process therefore provides a long term forecast of the required consumption $(P_{min}, P_{max})_{t, t_0}$ to the business entity (see figure 17). The forecasting method is based on the same analysis as presented in section 3.3.

The full process containing the translations between room state, bids, matching and forecasting is included in figure 20 (next page).

3.4.7 Global demand forecasting

Not all building processes are included in the provision of flexibility. These processes do however affect energy demand and may thereby influence decisions of the business entity. A general, global forecast of the building energy demand is therefore required. A forecast of the aggregated energy consumption has been developed based on historical data and weather forecasts. Artificial neural network (ANN) techniques are used to reduce computational complexity and guarantee high accuracy (Appendix A). This method for global demand forecasting can also be used separately from the priority based control.

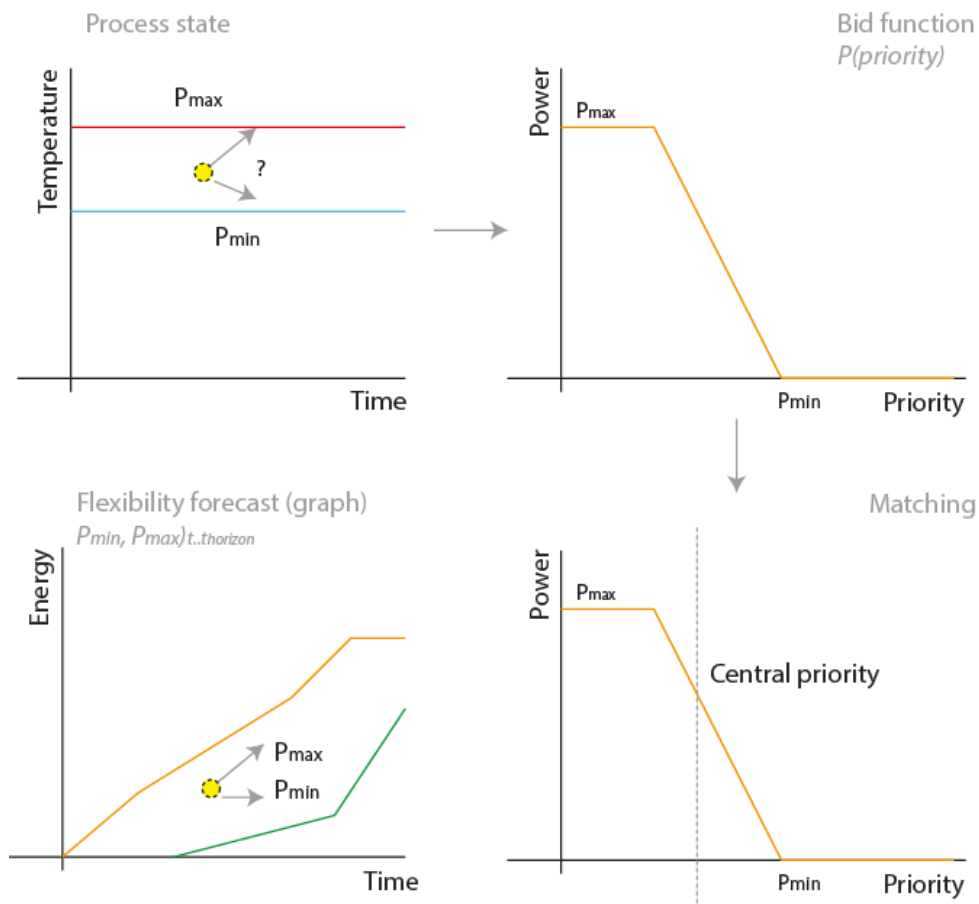

Figure 20: Process of state analysis, creating a bid, providing a forecast and matching the resulting central priority (here, a temperature regulating process is taken as example).

3.5 Flexibility and efficiency

Locally, a type of predictive control is used to enable flexible control. When considering optimal economical operation and flexibility, it is useful to consider the difference between flexibility and efficiency. When comfort margins are provided, an optimization could result in operating always on the lowest set-point. Integrating valuation comfort in the optimization can be used to reduce this behaviour. Efficiency and flexibility are defined as follows:

- Flexibility is the temporary adjustment the control goals in the present, to gain an advantage in the future. The deviation of the normal control goal has to be corrected after a certain period of time.
- Efficiency is concerned with the amount of resources needed to achieve a particular goal. This can mean that energy consumption is postponed; however, the goal is to use fewer resources over time (e.g. delaying heating if sunshine is expected).

3.6 Practical implementation

This paragraph discusses the required assets and infrastructure required to implement the concepts presented in the last sections.

Since the technological framework connects to user to the energy market, a bi-directional flow of information is required. Therefore, an on-site computer, a database, a coupling with the building management system (BMS) and an uplink a remote location for off-site analysis and management are required. The latter can be a cloud-based solution which reduces the need for storage requirements at the customer or provider side. This enables remote monitoring and control of building installations.

Most buildings constructed after 2000 have automated, digital control and are easily adaptable for communication and control from a remote site [30]. When a BMS is present, the implementation of the flexible control framework depends on the local situation. Usually a translation needs to be made to be able to communicate between different platforms active on different levels in the building (interfacing) [77]. Existing building management systems may for instance use BacNet [78], Lon Works [79], KNX [80] or other standards used for building automation. Among other protocols, Zigbee [81], or IP based protocols might be used for communication between devices and sensors. Given the variety of protocols and interfaces used, it is likely that a control layer needs to be added on top of the BMS (figure 21). Control of the installations is then performed by communicating set-points through the BMS. The added layer represents the information layer as included in the M490 framework shown in figure 9 [68].

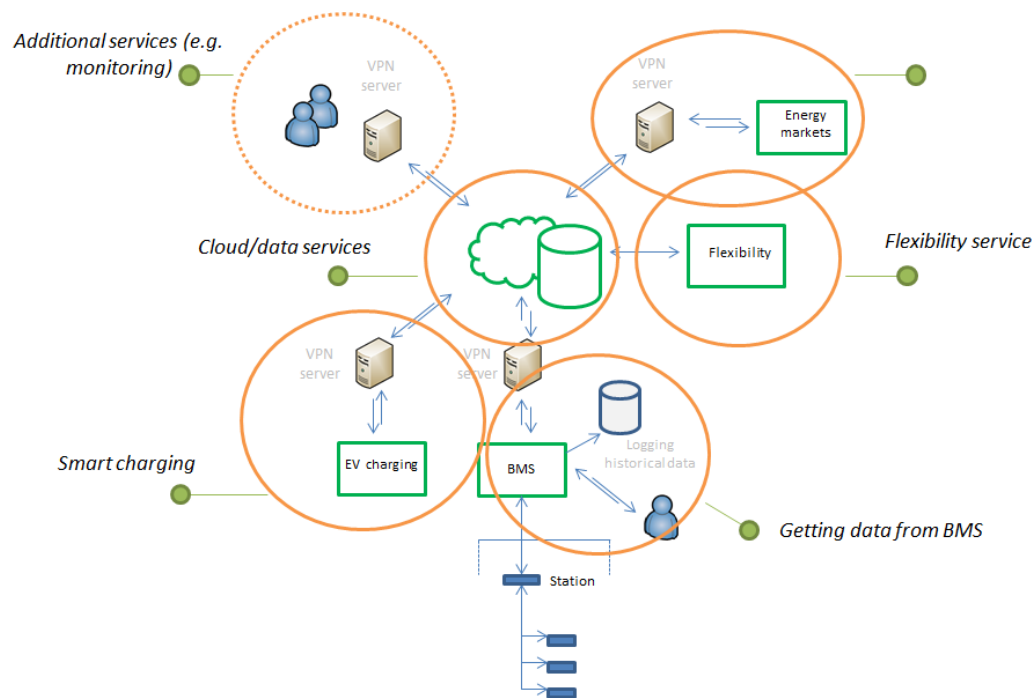

Figure 21: Implementation of flexible control in an existing building.

Infrastructure flexibility is essential to reduce maintenance, increase reliability and ensure expandability e.g. the plugin of a new sensor, or integrating a new installation should not require re-design of the system. A new sensor should, for example, be available for the entire system once it has been plugged in. The problem in doing so originates from the parallel development of building control systems and communication interfaces along with the use of closed standards/ protocols and the number of stakeholders in the building.

When the flexibility framework can be integrated with the BMS, or in case of a newly designed BMS, a more flexible infrastructure may be introduced. Various studies point out that a middleware backbone, which makes information available throughout the system, should be implemented [77,82]. In figure 22, a representation of a middleware solution is given. Middleware provides a translation layer and can make information from all components available throughout the management system(s). Existing standards can be combined to maximize flexibility and interoperability [77,82,83].

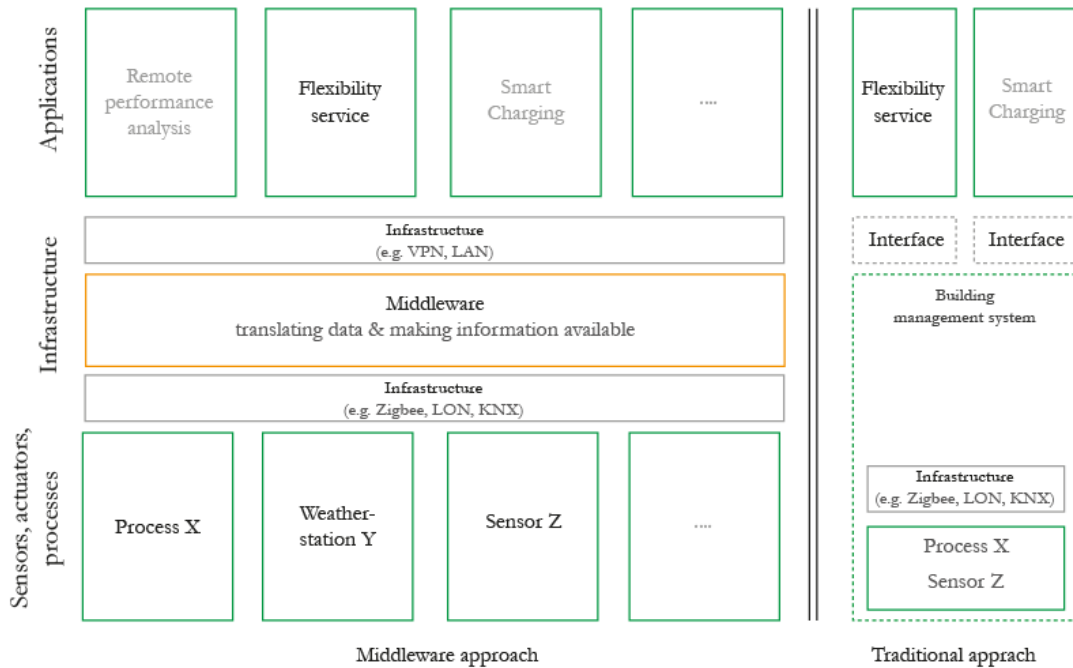

Figure 22: Potential implementation of flexible control in a new building. On the right an implementation with a middleware solution to enable the ‘plugin’ of sensors and applications. On the right a more traditional approach in which sensors and processes are included in the BMS.

To contribute to the integration of smart grid services in the BMS, and demand side management in particular, new standards are being developed. LON-Works is working on a smart grid protocol: “the Open Smart Grid Protocol” (OSGP) is targeted at utilities that want a multi-application smart grid infrastructure instead of a basic single function Automated Metering Infrastructure (AMI)” [83]. The OpenADR (open automated demand response protocol) is becoming popular for demand response schemes [84]. Also, there are many initiatives to develop standards for machine to machine communication, for example the Eclipse foundation [85]. These standardization efforts may help in constructing a framework for smart building communication and interaction with the smart grid.

Chapter 4: Building case study

The Eneco World Office subject of the SEC IPIN offices demonstration project and features as building case study to test the technological framework presented in chapter 3. In this chapter the results of the flexibility analysis will be presented.

4.1 Case background

The Smart Energy Collective (SEC) is a collective of companies related to the built environment, energy and ICT sectors working together taking a cooperative approach in developing smart grid services and systems [10]. Within IPIN five demonstration locations were chosen, one of which is the Eneco World Office (EWO). At the EWO, BAM Techniek, Eneco, Priva and GEN are investigating opportunities to introduce flexibility in offices.

4.2 Description of building

The EWO is the headquarters of Eneco, a major energy supplier in the Netherlands. Construction was finished in 2011. The building is optimally prepared to support ‘the new type of working’ (in Dutch: *‘het nieuwe werken’*), which is a flexible working paradigm in the Netherlands. The paradigm aims to reduce the required floor area per employee, reduce commuting, and increase employee freedom. The EWO facilitates 2,100 employees with 1,450 working places in a 30,000m² building. The building has an A++ energy label and contains a thermal storage (aquifer), connection to an urban heating infrastructure, and a ‘green façade’ that covers three stores. Furthermore, the building features 27 charging points for electrical vehicles. Finally, 138kWp of PV generation capacity is installed on the roof and façade. The system is expected to generate 90MWh of electricity per year.

The total energy consumption based on data measured in 2012 was 2.6GWh, which meets the A++ specification of < 0.5GJ/m².yr [14]. The consumption is expected to rise in 2013 as occupation increases. Heating and cooling is generated with heat pumps so gas consumption is limited. Table 3 contains an overview of the electrical energy consumption. The information is derived from data of the main meter between November 2012 and November 2013. The cumulative energy use is included in figure 23 in a load-duration curve ⁽²⁾. The average base load per 15min is 100kW while a peak demand of over 625kW exists for 10% of the time (approximately 3.5 hours per working day).

Table 3: Eneco World Office building electricity demand data

Base load	100-150	kW
Peak load	780	kW
Energy consumption	2,6	GWh
	0,3	GJ/m2
Contracted power	1,750	kVA
	1,000-1,400	kW

² The data series contains data for pre- and early stages of occupation. The building is (fully) in use since April 2012, figure 23 therefore contains data from the 2nd half of 2012.

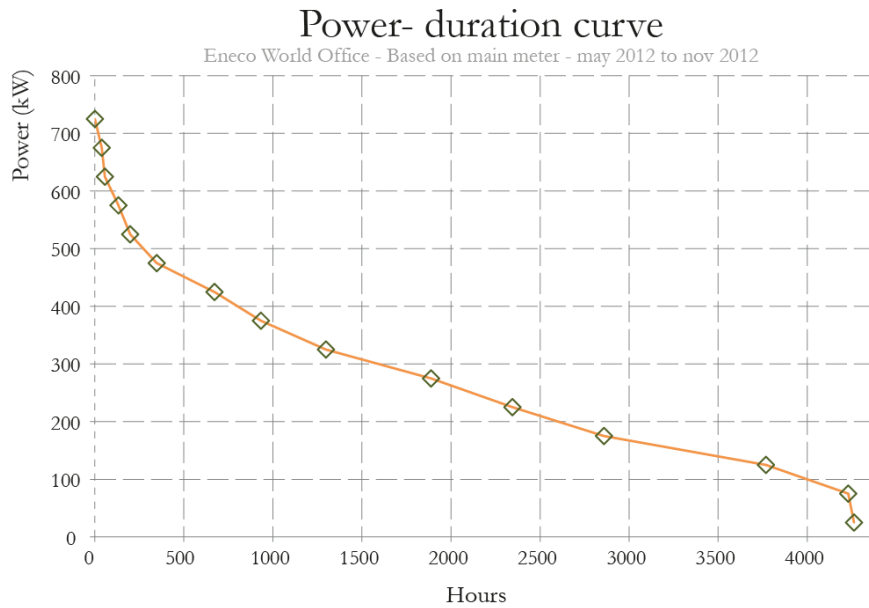

Figure 23: Load - Duration curve for the Eneco World Office. The curve is based on data measurements of the main electricity meter in 2012.

4.3 Example of demand forecasting

A demand forecast has been made based on an artificial neural network (ANN) that was trained with historic electricity consumption values. The ANN provides a 24 hour forecast. Results yield a coefficient of determination (R^2) of 0.95 and a standard deviation 15.3kW. This means that the deviation between forecast and measured values is lower than 25% for 95% of the time. Although the forecast performs well for most of the time, large deviations are still possible. The forecast methods depends strongly on the patterns: deviations from standard patterns might result in inaccuracies. An example of the forecast result is included in figure 24. Details on the forecasting methods are included in Appendix A.

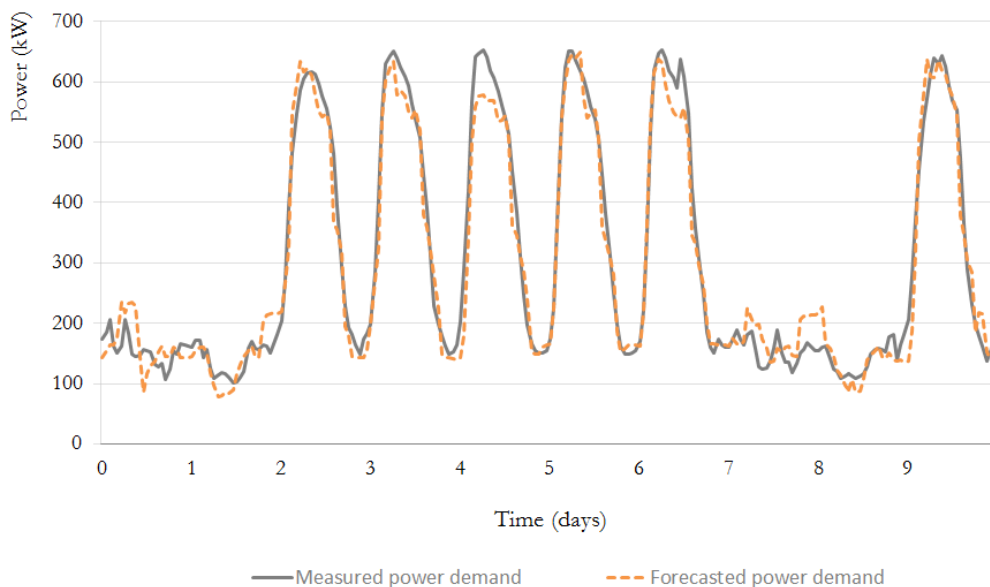

Figure 24: Energy forecast for a week in June (2012), forecast accuracy is high in general although a large deviation is observed on Wednesday.

4.4 Available flexibility

Since the EWO is a demonstration location for the SEC offices project, the learning goals are a driver for selecting sources of flexibility. The three main sources of flexibility investigated here are:

- Decentralized heating/cooling to gain experience in localized climate control, high resolution of forecasting, and investigate the influence on comfort.
- Electric vehicles because of their electric buffer capacity. Furthermore, charging of electric cars is relevant for the EWO as it features a number of charging stations and the charging facilities will be expanded in the near future.
- Sensible heat storage in a buffer vessel coupled to the heat pumps since this may provide high flexibility, has no direct effect on comfort and can lead to a feasible business case in the near future.

4.4.1 Flexibility from decentralized climate systems

The EWO climate installations can provide 157,000m³ of fresh air per hour. Heating and cooling is provided by heat pumps which have capacities of 1,750kW_{th} and 1,250kW_{th} respectively. From the central climate installation, ventilation is provided at 18°C (winter) or 15°C (summer) with a constant air volume (CAV) system. Air is heated/cooled centrally while decentralized units upgrade the air temperature to meet the required room temperature.

By controlling the energy demand of the decentralized climate installations, flexibility can be ‘unlocked’. Per m² about 41W of heating and 58W of cooling is available. Per unit approximately 4kW of heat and 5kW of cooling is available from the 45-35°C and 10-19°C heating and cooling distribution systems. For the decentralized climate control induction-, fan coil- and electric channel heater units are used. The units are controlled by the building management system (BMS). Controlling the local climate also offers opportunities to optimize comfort.

The user can provide a set-point between +/- 3°C around the central set-point of 21°C (daytime set-point). Flexibility becomes available by controlling the temperature within a bandwidth around the set-point provided by the user. A bandwidth of 1°C is assumed for the flexible operation of the systems; the influence on comfort is limited (see section 3.1, figure 10). A smaller bandwidth would be difficult to realize in reality considering the controllers.

The flexibility analysis is performed as described in chapter 3. The example room is modelled based on a meeting room located on the west façade. The model results have been validated with results from ESP-r (dynamic building simulation) and modelling details are included in appendix B. An example of the unconditioned temperature variation (free floating) of the room is provided in figure 25 for both a summer and a winter scenario.

The local climate model provides priority bid functions depending on the current state. In this case, linear bid curves are constructed based on the minimum and maximum power required at that moment. In the simulations, the maximum heating has been set to 30W/m². Examples of bid curves are included in figure 26 for different instances in time⁽³⁾. At instance 1, there is a high demand for heating (morning), while there is no need for heating on instance 4.

³ In the results presented in this chapter, time is expressed on the horizontal axis in program time units (PTU) which are used in the electricity system. The simulation time step is one minute, the models provide an update every PTU, so the process can be synchronized to the electricity markets.

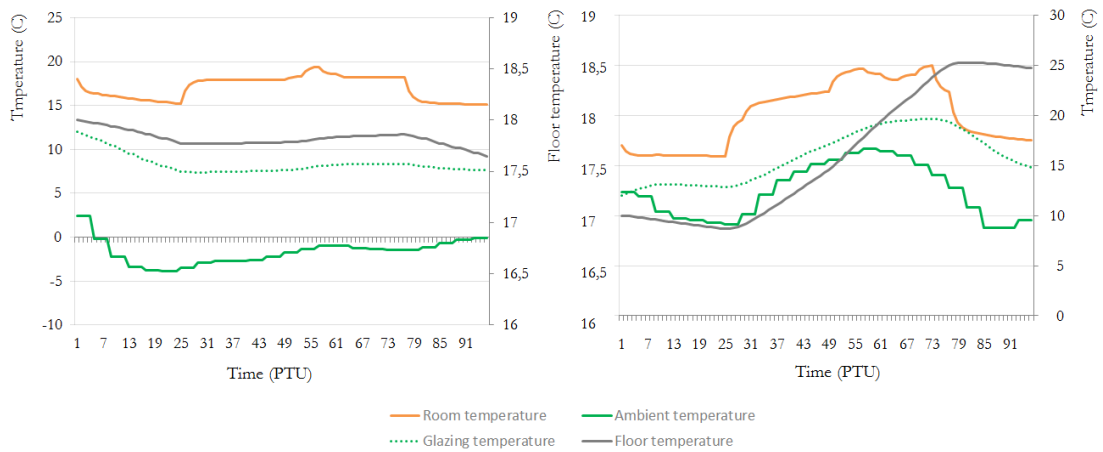

Figure 25: Free floating temperature of a room for a winter (left) and a summer situation (right). Internal gains, ventilation and environmental effects are enabled. The temperature of the thermal mass is plotted on a secondary axis to demonstrate variations.

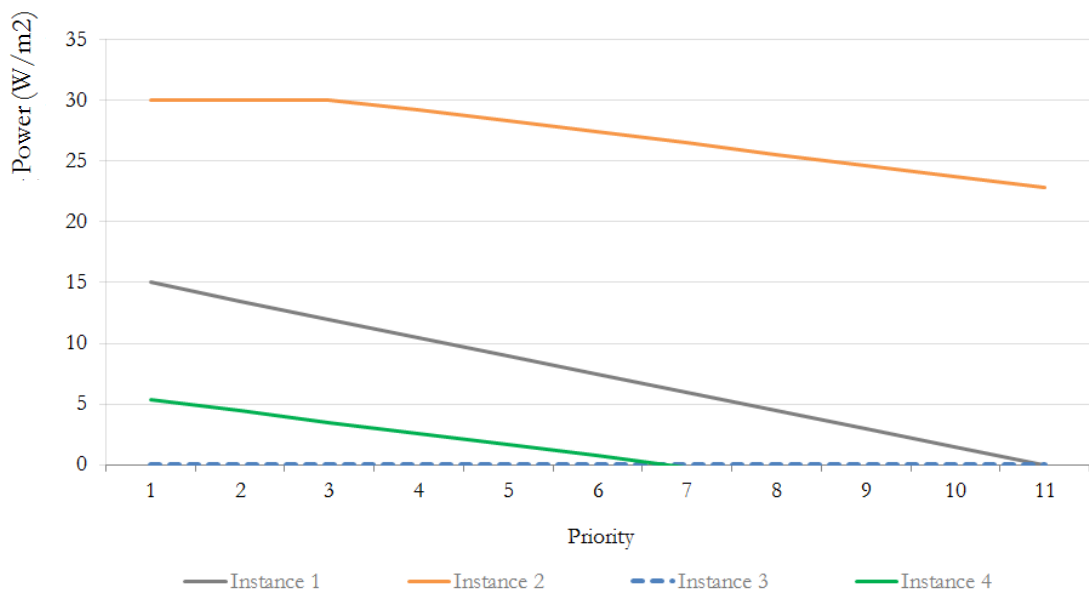

Figure 26: Example of bid curves for the room climate control in the Eneco World Office.

Flexibility curves have been constructed for a day in winter, see figure 27. The required minimum and maximum energy consumptions at the end of the day are different from each other as a result of differences in heat losses and heat storage which depend on the temperature.

The flexibility is strongly dependent on the used user profiles. From figure 27 it can be seen that the demand for heating is much higher with low occupancy ($2,5\text{W/m}^2$) when compared with a situation in which there is high occupancy (5W/m^2). If the building is intensely used, no decentralized heating may be required to reach the lower temperature limit (dotted green line in figure 27). Flexibility is higher for the situation in which occupation is lower and demand is higher.

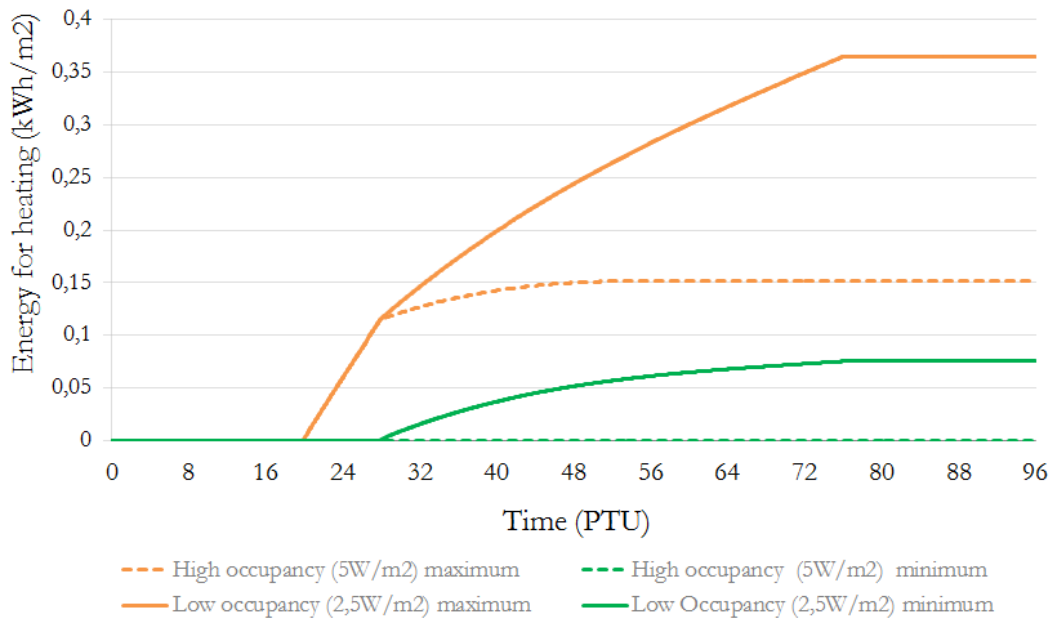

Figure 27: Flexibility graphs for different occupancy scenarios for a single room.

The available flexibility is not only sensitive to occupation. Heat losses from the room air are depending on the climate and the state of the thermal mass. The exposure of the thermal mass to the room air has a significant effect on flexibility as heat transfer to the mass is easier when the mass is exposed to the room air. Heating the mass takes longer if the mass is not exposed, for instance, when the concrete is hidden behind panels. The effect on the flexibility forecast is demonstrated in figure 28. In this figure, it can be observed that demand is higher when exposure is high; more heat is transferred to the mass. A part of the provided energy is lost to the environment and by ventilation, another part is stored in the thermal mass depending on the exposure of the thermal mass, and the façade composition (see figure 29). Only 30% of the heat is stored in the mass for the non-exposed case ($U = 1.58 \text{ W/m}^2\cdot\text{K}$), while 65% of the heat is stored in the exposed case ($U = 7.6 \text{ W/m}^2\cdot\text{K}$).

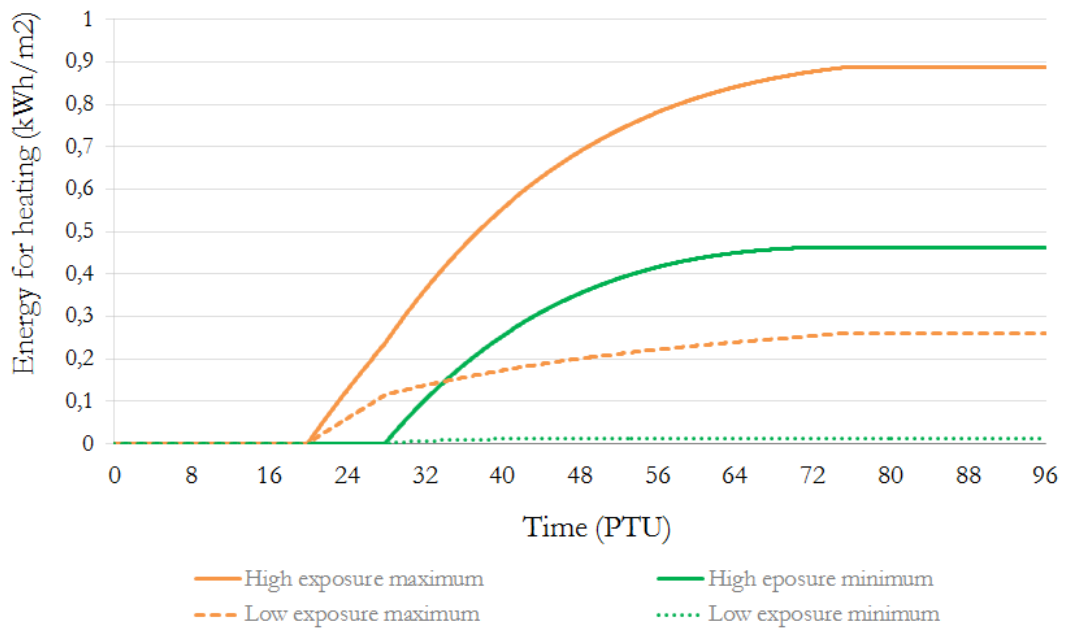

Figure 28: Flexibility graphs for different 'exposures' of the thermal mass to the room air.

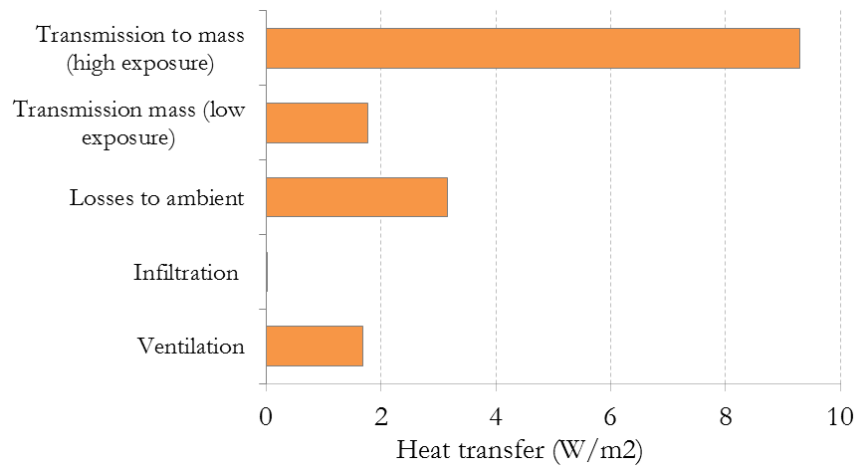

Figure 29: Example of heat transfer from the room air through the system boundaries. Wall temperature is 18 °C, room temperature is °C and ambient temperature is 8 °C.

When using flexibility, energy needs to be stored to be able to reduce demand at a later moment. The effect of heating the thermal mass is included in figure 30. In this example, preheating is applied and energy is stored in the thermal mass. During the day, the derivative of the preheating case heating curve is slightly lower compared to the non-preheating case. At the end of the day, more energy is consumed in the case where preheating is applied. The longer term effect of heating and cooling the thermal mass should be investigated further to determine the effect on efficiency, comfort and flexibility.

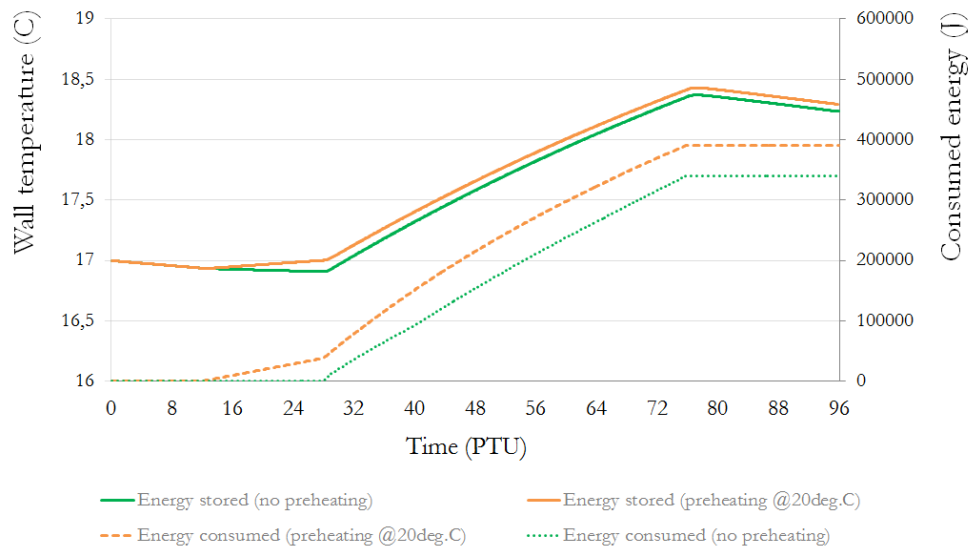

Figure 30: Example of effect of preheating the thermal mass.

When considering the short term flexibility, the role of thermal mass is insignificant. The time constant (τ) for the thermal mass is in the range of one hour to days while the time constant for the air is in the range of minutes. Air is ventilated at 18 °C with high ventilation factors ($5\text{m}^3/\text{m}^2\text{hr}$); the response of the room temperature is therefore fast. Demand can only be postponed by about 15-30min as comfort limits are reached relatively quickly. From the flexibility graphs, the maximum postponement is not clearly seen; effects of losses, which depend on the trajectory through the graph, are not included in the graphs. A maximum energy consumption postponement of 15-30min is the maximum service interruption per room: overall flexibility can be maintained longer. The flexibility for a day in winter and a day in summer is included in figures 31 and 32 respectively.

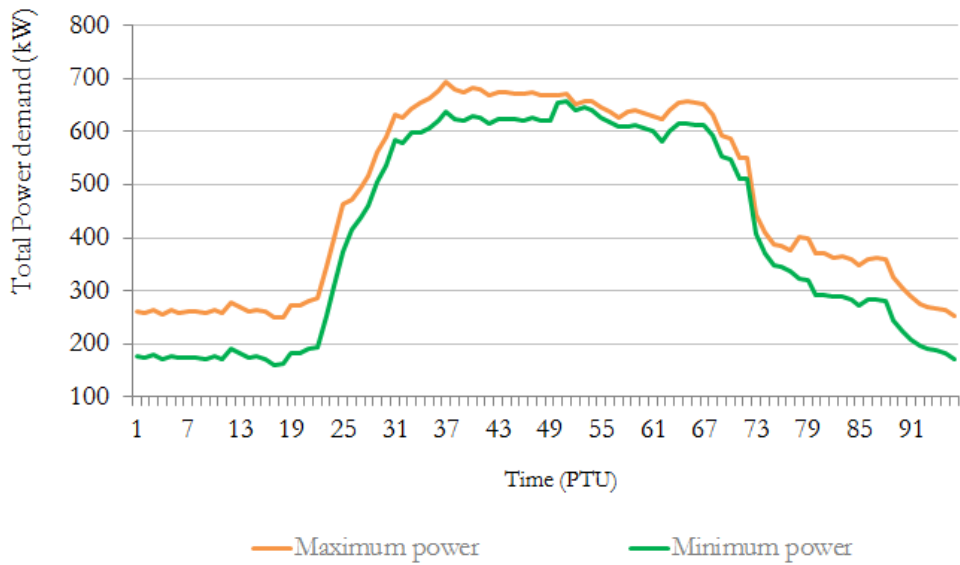

Figure 31: Flexibility of decentralized climate system for a single day in winter.

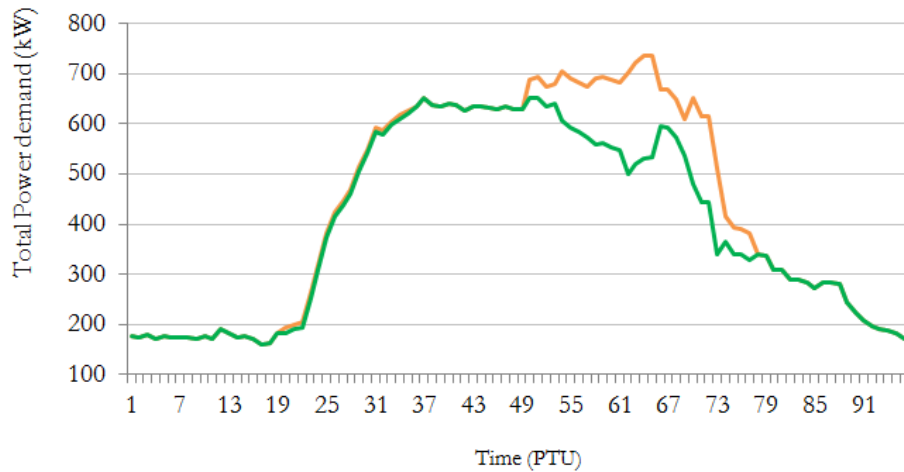

Figure 32: Flexibility of decentralized climate system for a single day in summer.

From figures 30 and 31, the advantage of the flexibility graphs becomes clear as the graphs describe the available power flexibility, but provide no information on the resource availability. In winter (figure 30), there is flexibility during the whole day. At night, the building can be preheated or -cooled. In summer flexibility is limited during the night and early day as no heating or cooling is required (although precooling could be allowed). The example room has a large window on the west side. Irradiation increases the cooling demand in the afternoon leading to increased flexibility. The total expected flexibility, is presented numerically in table 4 based on the analysis of summer and winter scenarios.

The usability of the flexibility in the decentralized heating and cooling systems also depends on the response time. A change in decentralized heating and cooling settings leads to a change in the required energy from the heat pump. The response time describes the time difference between the implementation of the control signal to in- or decrease demand, and the time a difference is measured on the heat pump. The response time (included in table 4) thus depends on the distribution system. It is estimated that it takes between 200-300 seconds before any changes in electrical energy consumption can be measured at the heat pumps (given 1m/s water displacement in the average distribution system pipe diameter).

Table 4; Available flexibility from decentralized heating and cooling for the total building.

	Average available flexibility (kW)	Maximum demand postponing (min)	Time at maximum power (min)	Response time (s)
Summer	30	15 - 30	15 min	200 - 300
Winter	42	15 - 30	15 min	

4.4.2 Flexibility from electric vehicles

The EWO features 27 charging points for electric vehicles. In the near future, this number will be expanded to 44 charging points. Plug-in hybrid electric (PHEV) vehicles are available for lease and trial projects to encourage the use of PHEVs have been started. The pool of charging poles consists of traditional charging points of 3.7kW and 11kW and one fast charger of 50kW. The peak capacity of the charging poles is currently 223kW and expected to grow to 476kW. The poles (3 phases) are connected to a feeder from the local transformer.

Various types of PHEVs are available on the market. The average battery capacity is assumed to be 10kWh, this assumption is based on currently available PHEVs such as the Toyota Prius (5.2kWh) and the Chevrolet Volt (16.5kWh) [86, 87]. Measurements from the charging poles indicate that the average charged energy is 6.3kWh and the maximum energy was 12kWh. When it is assumed that each point is used once per day to charge a car to its maximum capacity, 270kWh is consumed. It is assumed that the average battery capacity in PHEVs increases to 15kWh in the upcoming years, which is similar to the larger batteries found in PHEVs today. An overview of the charging poles is presented in table 5.

Table 5; Overview of electric vehicle charging points.

	Currently	Future (5 years)	Increase factor
Number of charging points	27	44	1,6x
Total peak capacity	223kW	476kW	2,1x
Maximum energy consumption per day	270kWh	660kWh	2,4x

The available flexibility depends on the arrival and departure times of the electric vehicles. The process model therefore contains models for user arrival and departure behaviour. Two main user schemes are considered:

- Scenario 1: Employees arrive and leave at approximately the same time.
- Scenario 2: Employees arrive at approximately the same time, but leave at different times during the day.

For the arriving cars a random state of charge (SOC) between 0.1 and 0.8 is generated to simulate differences in distances. The load efficiency is assumed to be 0.9 (90%). It is not expected that cars will be able to feed energy back into the building in the near future: this option is therefore not included in the simulations. An overview of the model is available in appendix B.

The flexibility graphs, are included in figure 33 for a fleet of 44 electric cars. The green line represents the case in which users leave at approximately the same time, while the grey curve represents the situation in which cars leave at different times during the day.

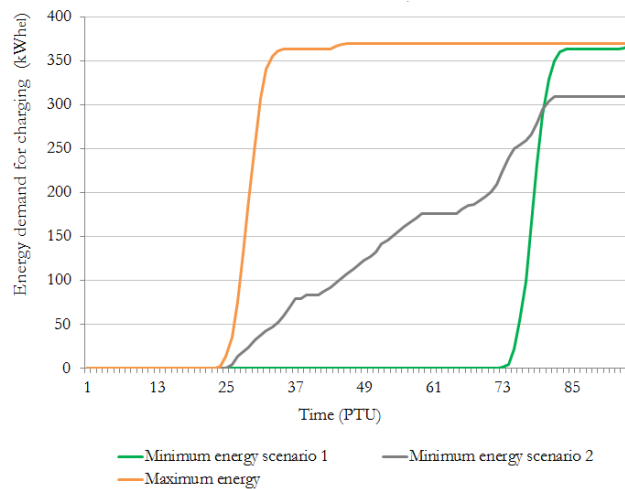

Figure 33: Flexibility of electric vehicle fleet (44 cars) with different user profiles.

Different from the decentralized heating and cooling case, the flexibility curves converge to the same energy level. All cars have to be charged at the moment that they are needed. Although losses are included in the models, the effect is relatively small and not visible in the graphs. As can be concluded from figure 33, the user profile has a major influence on the available flexibility. When cars leave at different times during the day, it is possible that cars are not fully charged when they leave (it is assumed that an owner takes his/her own car, and not a fully charged one). Compared to the flexibility in the decentralized heating/cooling case, the flexibility of electric cars is large. An example of the available flexibility during a day is included in figure 34, for the scenario where cars leave at approximately the same time.

Flexibility is only available if the charging is postponed when cars are connected, else a demand peak would occur in the morning (size of the maximum power demand curve). At the end of the day, the minimum power demand increases since all cars need to be charged on time. When cars would have been charged during the day, this peak would however not occur. Such effects are more clearly visible from the flexibility graphs presented in figure 33. An overview of the total expected flexibility for all scenarios is presented in table 6.

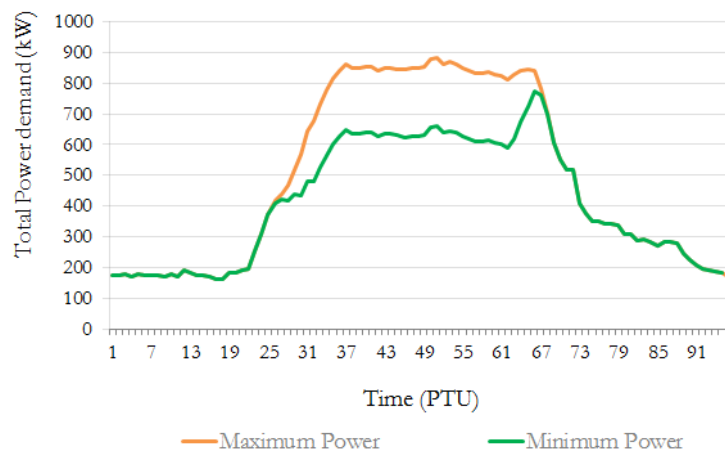

Figure 34: Electric car flexibility during a single day. The figure represents the current situation (27 chargers) for the scenario in which employees arrive and depart at approximately the same time.

Table 6: Available flexibility from electric car charging for different lease scenario's and user profiles.

	Average energy (kWh) charged	Average available flexibility (kW)	Maximum delay in cons. (min)	Maximum time at full power (min)	Response time (s)
PHEVs 27 chargers (present situation) scenario 1	155	81	90	42	0*
PHEVs 27 chargers (present situation) scenario 2	140	70	75	39	
PHEVs 44 chargers scenario 1	368	172	120	46	
PHEVs 44 chargers scenario 2	387	122	120	48	

* Nearly zero assuming direct response to the control signal.

4.4.3 Flexibility from storage buffer

While the decentralized heating and cooling systems provide an opportunity for flexible control when offering the potential for comfort optimization, the available flexibility is limited, it is depending on occupation profiles and subject to a complex environment. Also, response is expected to be slow. A sensible heat storage buffer may provide a more predictable and controllable source of flexibility.

Such a buffer can be placed behind the heat pumps and decouples the demand for heating or cooling from the operation of the heat pumps. The heat pumps have an approximated coefficient of performance (COP) of 3.5, and the COP dynamics are not included in the modelling. The maximum heat transfer to and from the storage is depending on the applied heat exchangers, mass flow and temperatures. The buffer is a sensible heat storage using water as storage medium. An overview of stored energy versus buffer size is included in figure 35 for a case in which the maximum heat transfer is 350kW_{th} (100kW electrical power flexibility).

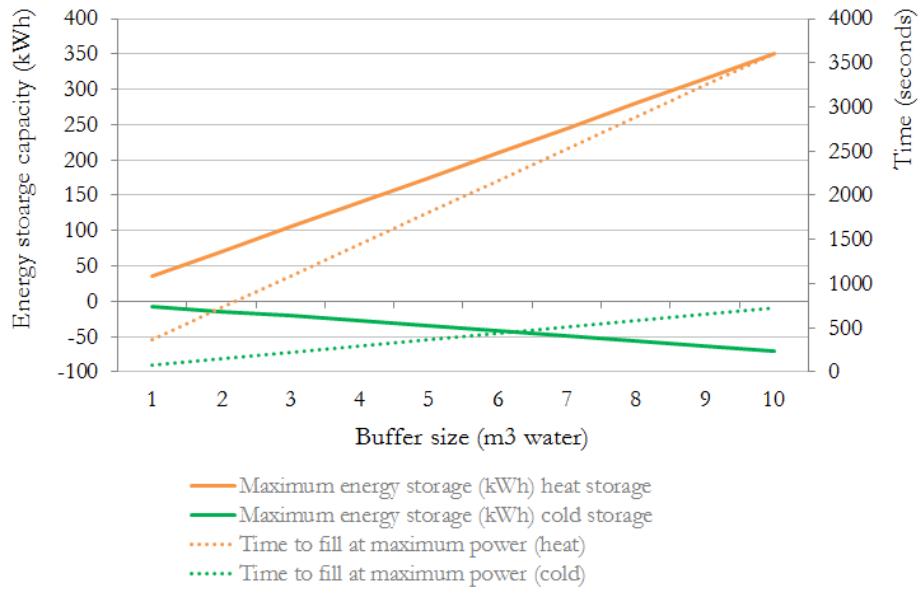

Figure 35: Buffer size versus storage capacity. Including fill times when a maximum power of 350kW is assumed.

The buffer is coupled to the heat pumps, which provides heating/cooling and the building distribution system (demand side). For simulation purposes, a demand profile has been constructed based on the general electricity consumption data and the decentralized heating/cooling model. The storage vessel is insulated ($5\text{W/m}^2\text{K}$) and heat losses are included in the models. The maximum storage temperature is 60°C , the minimum storage temperature is 30°C (return water temperature from the heating system). In cooling mode the minimum temperature of the storage vessel is 4°C , maximum temperature is 12°C . A schematic representation of the model is included in appendix B. The size of the storage vessel is not optimized: figure 36 includes the flexibility curves for a 10m^2 storage facility for a single day.

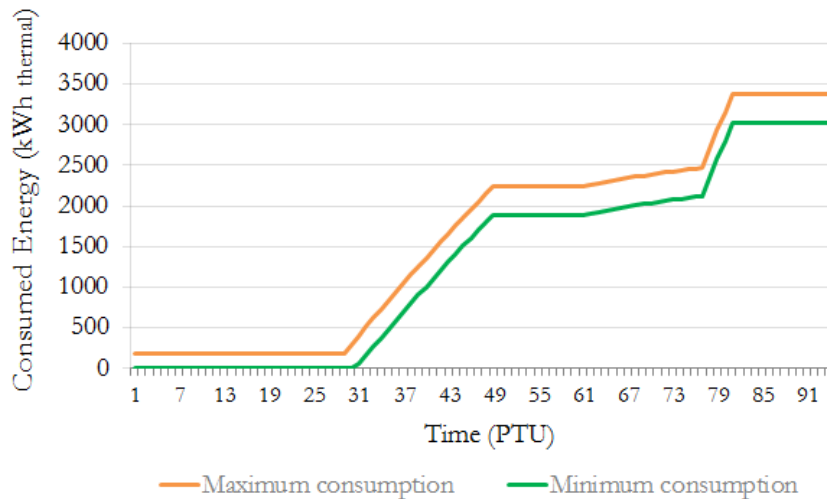

Figure 36: Flexibility curves for a sensible heat buffer system coupled to the heat pumps (winter day) for a 10m^3 buffer.

In figure 36, there is a demand for heat in the morning and the evening. The flexibility is mainly depending on the demand. When there is no demand, the buffer can be filled up to its maximum capacity, but no further flexibility would be available. An overview of the flexibility is included in table 7.

Table 7: Available flexibility from a sensible storage buffer connected to the heat pump and distribution system.

	Average available flexibility (kW)	Maximum demand postponing (min)	Time at maximum power (min)	Response time (s)
Storage buffer (heating)	100	Depending on demand (average 60 min.)	60	0*

* assuming the effect is directly measured on the heat pumps.

4.5 Market based optimization

The flexibility can be used to gain advantages on the market. The business entity is responsible for making decisions about the use of flexibility. The goal of this paragraph is to demonstrate the operation of the business entity by testing the optimizations.

The response of the business entity (optimizer) to an example price signal is included in figure 37. When prices are relatively low, the priority to consume energy is generally high. The priority to consume energy increases just after a price peak. When the priority is low, a process will try to minimize energy consumption while maintaining comfort (e.g. interruption energy consumption when possible).



Figure 37: Priority response to price signal.

4.5.1 Market based optimization of decentralized climate systems

As the decentralized climate systems respond slowly to flexibility requests, the flexibility could be most useful in gaining advantages on the APX market. Optimal economical operation of heating/cooling systems can lead to operation on the lower comfort limit. In order to distinguish efficiency effects and the actual benefit from flexibility, results are compared to the 'normal operation in the lower temperature range' rather than to a reference controller.

Optimizations were performed with price signals based on APX clearing results [20]. The prices have been adjusted to include distribution costs and tax. The response of the temperature is included in figure 38. Here, the temperature increases above the 'normal operation' in the morning when prices are low. No preheating is observed during the night however. An extreme price scenario is included for comparison. When the optimization is based on the extreme price signal, preheating is observed in the night. This is because of the limited storage efficiency, which is lower than the price difference when using the normal price profile so preheating is not cost effective.

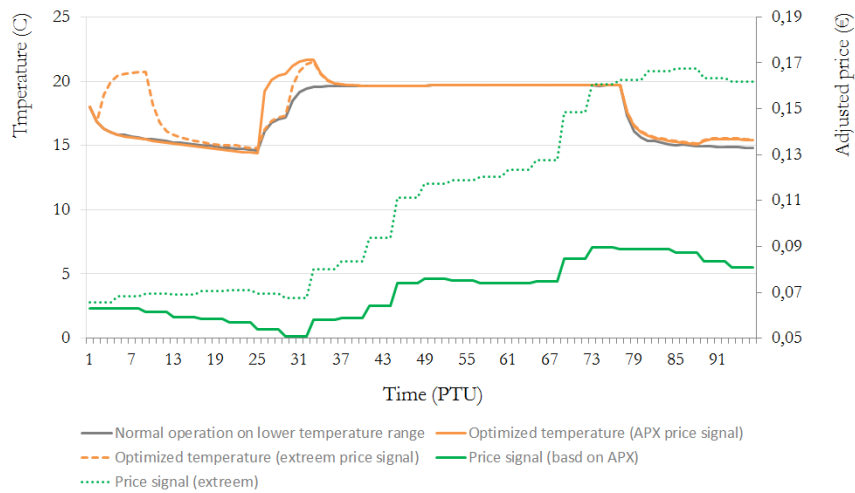

Figure 38: Optimized temperature for optimizations based on different price signals.

The optimizations are included in the flexibility graph presented in figure 39. A simulation based on the suggested optimum result is performed after the optimization to validate the optimization results. In either of both optimized simulations using a ‘normal’ and an ‘extreme’ price signal the simulation implementing the optimum suggestion, follows the optimization. While the optimizer assumes that most locations between the minimum and maximum are valid, in reality, there is a minimum power consumption. This minimum consumption is not exactly equal to the derivative of the minimum energy consumed; it may depend on the trajectory taken. This effect has a major impact on the costs saved since additional heating/cooling is required which is not taken into account in the optimization.

The optimization results show an insignificant economical benefit (range of 1-2 euro per day for the whole building), when compared to a case in which the temperature is controlled to be at the minimum set-point). The result simulation, based on the suggested optimum, shows no benefit at all. The optimization is currently unable to take into account long term effects of thermal mass heating and cooling since the optimization horizon is 1 day. Reports indicate that preheating and cooling can be financially beneficial [e.g. 40]. The focus of the current study is however different since only flexible operation (and not efficient) operation is considered.

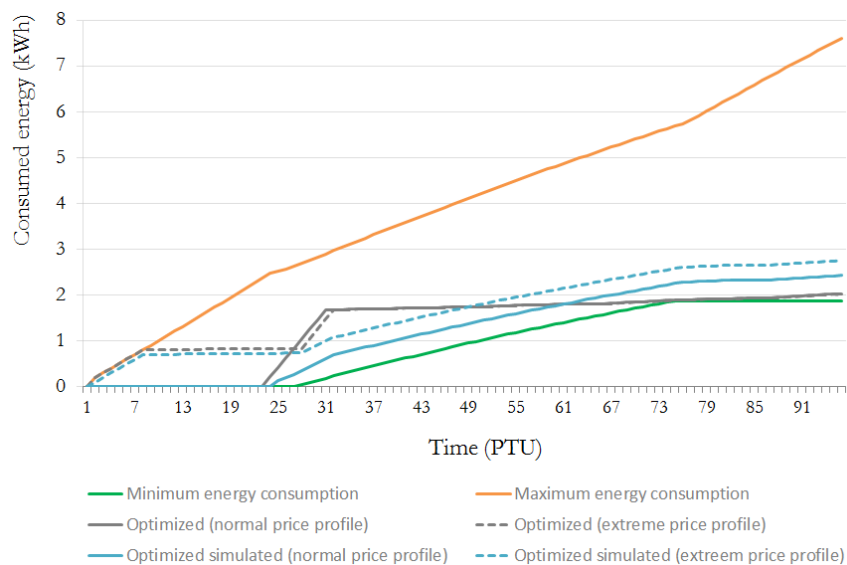

Figure 39: Optimized energy consumption for different price signals.

4.5.2 Market based optimization of electric vehicle charging

The charging of electric vehicles forms a major contribution to the total power demand of the building. The expected increase in the amount of EV chargers may result in a required increase in contracted power. Possibly, a new transformer is required as the physical capacity of the transformer is 2,300kVA. Flexibility from the electric cars can provide value by reducing the required capacity and optimal APX purchasing strategies. Furthermore, it can contribute to balancing portfolios. The imbalance market operation is however not considered here.

Two types of optimizations have been performed: one for purchase of energy when APX prices are low (but with unlimited load capacity), and one in which load is minimized. For the latter optimization, a cost function in which the costs per kW increase with the power demand is included in the optimization. The optimizations are performed for a fleet of EV's which provide individual bid functions. Results are included in figure 40, which includes the flexibility graphs for cars that are charged at night.

In figure 40, the grey dotted line represents a case in which the cars are charged at the cheapest moment. In the case of electric car charging, the result simulation follows the suggested optimum. The capacity is assumed to be limited only by the charging capacity of the poles. The charge cost is reduced with approximately 0.035 €/kWh. The full line represents the case in which the demand is also minimized. The total load is reduced by 60% compared to the maximum peak that would occur if all cars would charge at the same time.

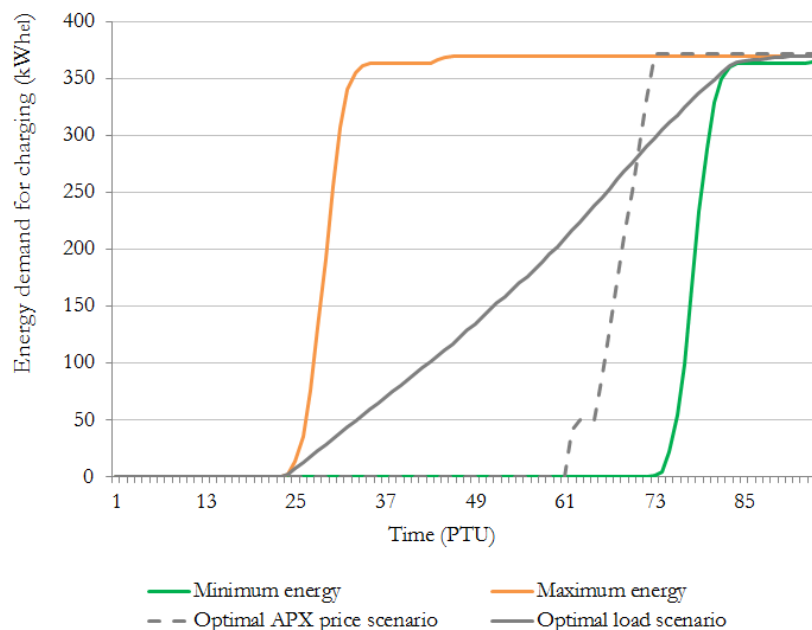

Figure 40: Optimizations for EV charging. Both capacity- (grey line) and optimal purchasing schemes (dotted grey line) are included.

4.5.3 Market based optimization of buffer vessel

The storage vessel can be seen as a source of flexibility in series with decentralized heating/cooling systems. The buffer can be used to find the optimal time for energy purchase.

A case for optimal economical operation depending on APX prices has been simulated. Value is attributed to the stored energy so the optimizer can consider to keep the buffer filled at the end of the day. The result is included in figure 41. Figure 41 contains the result for a large, 100m³ buffer.

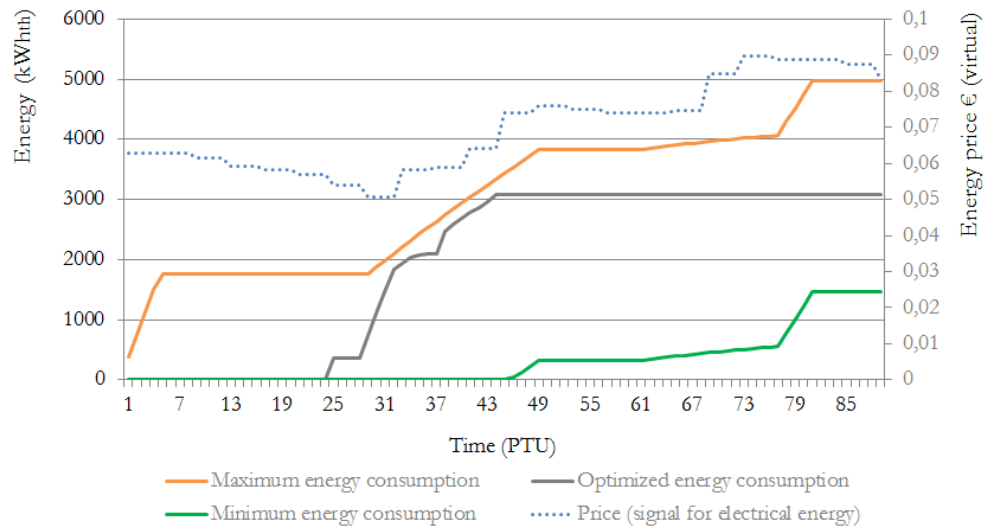

Figure 41: Optimal buffer operation for a day in winter.

From figure 41, it can be seen that the buffer fills at times when energy is relatively cheap. For demonstration purposes, optimizations have been performed using an example price signal passed on APX clearing data of 2012 [22]. Prices are adjusted to include taxes and transport costs is assumed. A building heating demand profile is constructed based results from the decentralized heating/cooling system simulations for a winter scenario. With these assumptions, a saving of approximately 5 €/day per day is possible for a 100m³ storage tank when the buffer is used for optimal energy purchase schemes. Using a 10m³ tank may lead to about 4 €/day of savings under the same assumptions.

Chapter 5:

Market opportunities for provision of flexibility services

While the economical value of flexibility was introduced in chapter 2, the feasibility and potential of flexibility services depends on market size, opportunities and required investments. In this chapter the market opportunities are explored.

The current project focuses on flexible control, which can serve both user needs and the needs in the energy sector. The integration of flexible control in buildings should thus be seen in the perspective of energy servicing. Considering the amount of ‘smart service definitions’ [88], we are free to choose our own definition. Smart energy services consist of three elements: *monitoring*, *energy management* and *performance improvement* (see figure 40).

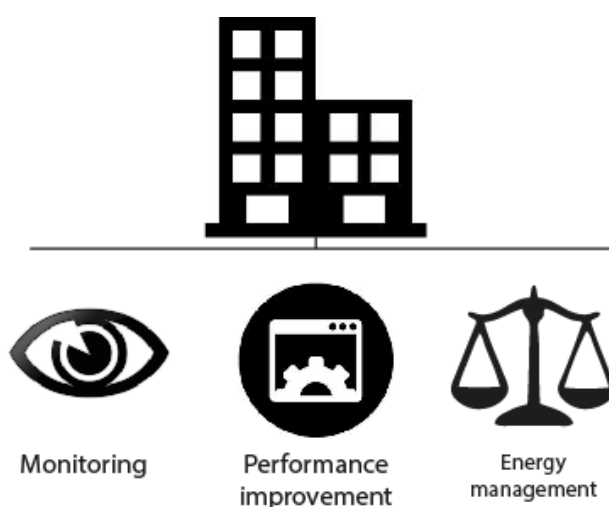

Figure 42: Smart energy services.

BAM is already active in the smart services sector, with offerings for energy monitoring and performance improvement. Integration of smart grid solutions into buildings strengthens both the monitoring and performance improvement pillars while offering the opportunity to provide energy services to the electricity system. Up to now, energy management services are focused on heat (aquifers) and electricity contract management.

5.1 Evaluation of market status and growth

Opportunities for the provision of flexibility services depend on the status of the economy and the target segments. Therefore, a market analysis is performed.

5.1.1 Energy and smart grid

The energy sector is a large industry. The total electrical energy consumption in the Netherlands is 122,057 million kWh (in the year 2012), leading to an approximate turnover of 40 billion euro [15]. Since energy is a commodity, margins are generally low. Energy supplier margins are between 2% and 10% for large industrial- and smaller contracts respectively.

The market for ‘smart grid solutions’ has grown in size with 40% per year since 2005. Studies indicate that the *potential* market in Europe is approximately 13 billion in 2014 [89]. For the ‘consumer application and advanced metering’ segments the global market *size* is estimated to be worth 23 billion in 2014 [90]. From figure 41, which considers the US market alone, it can be observed that demand response is already an important part of the total market value

[91]. While demand response schemes have been applied at large industrial sites for years, demand response on the side of customers in the built environment is still developing. An average annual growth around 9% is expected for the upcoming years [90]. The smart grid industry, which involves different segments of the current energy, ICT and building industries, is entering a growth phase. All major technology companies (e.g. Cisco, IBM and ABB) are investing in the smart grid technologies and have incorporated the smart grid in their core businesses [90, 92].

Currently, at least 70 companies are active in smart grid related developments in the Netherlands (excluding governments and universities) [93]. The next step in smart grid (market) development is commercial application of advanced smart grid functionalities. Emerging companies like Enevalis (Belgium), Enernoc (US), Voltis (France) and ReStore (Belgium/UK) are already focussing on the provision of aggregator services and demand side management services. The development of smart grid technologies is supported throughout industry and governments. Besides subsidies, governments support the implementation of smart grids with directives. An example of such a directive is the mandatory rollout of smart meters by the EU [94].

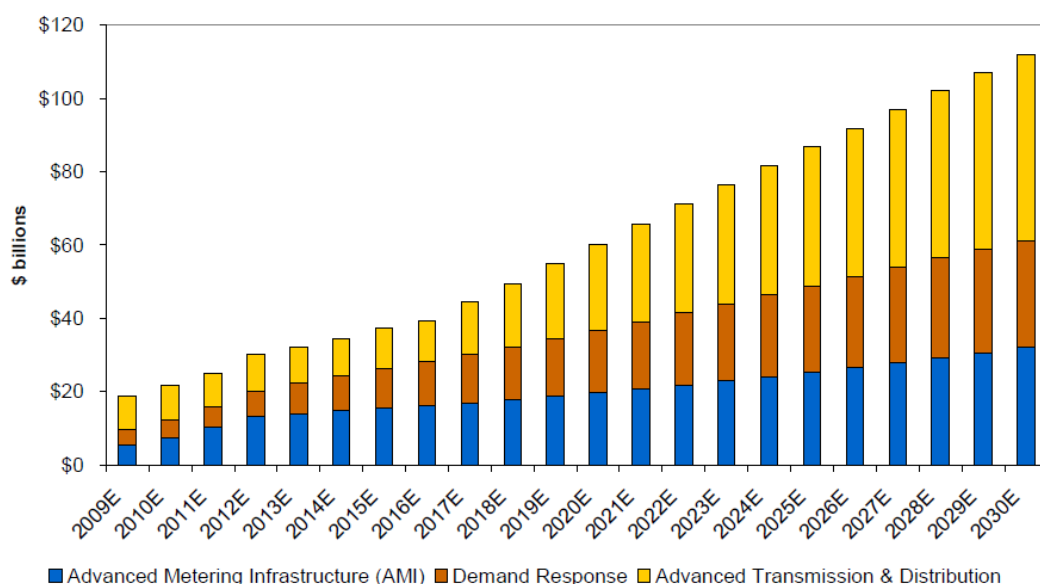

Figure 43: Smart grid market growth in the US [95]

5.1.2 Opportunities in the building industry

Since smart energy services are related to the building industry, a market analysis of this industry has been performed to find opportunities for new service offerings.

The Dutch construction and building services industry is facing a major crisis. Office and residential vacancy is 15% and 4.7% respectively [95,96]. Investments in real estate have been low; in a constant decline since 2007, total sum -50% compared to 2003 [15,97,98].

Indicators for the market development are slightly positive as the macro-economy shows signs of recovery [15]. Although investments have been low, there is still a demand for new high quality office buildings [97,98]. The demand for high performance buildings also leads to opportunities for building refurbishment. The Dutch refurbishment industry is expected to grow with 13% (16.7 billion) in 2014. Initiatives for building refurbishment are numerous e.g. ‘green lease’ [99] and ‘tijdelijk duurzaamhuysvesten’ [100] (temporary sustainable housing). It is expected that office vacancy reduces to 7% in 2020.

Considering the energy services sector, studies indicate that the Dutch market is developing slowly in comparison to other European countries [28]. This slow development is mainly attributed to economic- and conservative business aspects. Considering the growth of smart grids, the growth in refurbishment and the demand for high performance buildings, it is evident that there are opportunities for the building services sector.

5.1.3 Office buildings as a target segment

Three main consumers are identified when analysing energy sector: transportation, industry, and buildings. The last segment accounts for 37% of the total energy consumption [3,16]. When concentrating on energy consumption in buildings, two main segments can be distinguished: commercial buildings and residential buildings. This study considers flexibility in office buildings, which are part of the commercial segment.

Traditionally, energy suppliers have a strong position in the residential market. But, there are a number of technological and legal challenges that reduce the potential of enabling flexibility in residential areas in the short term future. The residential segment is therefore less interesting at this moment.

When considering integration of smart grid concepts, office buildings differ from residential buildings in several ways. The value perception of stakeholders is different, since the end-users are not the (main) risk owners, larger installations are present and usually a management system is present. The latter simplifies the integration of advanced control schemes and potentially reduces the required investment per kW of flexibility (in residences, control systems need to be integrated). However, performance demands are higher compared to residences.

Currently, there are over 78,000 office buildings in the Netherlands [15] with a total of almost 50 million square meters. Studies analysing the status of the existing office market show that high performing buildings are in demand and low performance buildings cannot compete [97,98]. Office renters do not choose the cheapest offices, as 32% of rented office space in 2012 was relative expensive (180+ €/m² rent). Office refurbishment forms an attractive segment for provision of energy services. 71% of all office buildings has a label below C, 30% is either D or E label. 25% of office space is built after 2000, indicating a lifetime up to 2070.

Not all office owners are in the position to pay for the upfront investments needed to make the buildings more energy efficient, because they already have to take the losses of the diminishing values of their portfolios [29]. When all buildings are updated from label C to label A, an energy saving of 0.15GJ per m² is reached. This translates to 300GWh/yr and a market of 100 million/yr if 50% of savings are for the energy service company (ESCO). When all offices (also <E label) are considered, the size of the ESCo market would be approximately 600 million euros annually. Literature supports these numbers as estimations reach between 250 and 500 million [28,29].

The realization of energy savings is not the only important opportunity. A study performed in Dutch offices indicates that 25% more energy is consumed in buildings than expected, costing 200 million each year [101]. Up to 70% of installations does not function adequately, and in 90% of all buildings have comfort complaints.

High performance offices are in demand. Since this performance needs to be guaranteed there is a role for smart services and flexibility. It is concluded that there are major opportunities for energy service provision in the office sector.

5.2 Feasibility of flexibility services

In this paragraph the feasibility flexibility services is studied in two cases: a) the enabling of flexible control using a flexibility source in the building and b) a case which demonstrates the potential of participation on the electricity markets.

5.2.1 Potential of case study examples

Based on the flexibility analysis, the optimization tests and the potential market value, the feasibility of providing flexibility services using the case study examples can be investigated. Here, the conclusions of this analysis are presented to gain insight in the feasibility of flexibility services.

It is assumed that the required assets to perform flexibility operation are installed in the building. The underlying business cases are calculated based on prudence principles. Furthermore, the cases have been considered separately meaning that the costs of the control assets are included in each case. The business cases consider reductions in peak demand and optimized purchase schemes. Contributions to portfolio balancing are not included here, but are considered in the following section.

- The flexibility gained from the decentralized climate systems does not lead to a feasible business case by itself. However, it can contribute to flexibility services when combined with the other example cases.
- For the electric car example, there is a feasible business case for the future. A benefit in the range of 2000-2500 €/yr is possible by reducing the peak demand (resulting from simulations assuming an EV fleet of 44 cars in the EWO building). An internal rate of return (IRR) of 6-7% is realistic for this type of project.
- For the buffer vessel an IRR of 5% is possible considering optimal fill/use cases where energy is purchased at optimal times.

5.2.2 The value of participating on the wholesale markets.

Flexibility can contribute to risk reduction in energy contracting by reducing overall energy costs. Apart from load reduction and optimal purchasing schemes, flexibility can contribute to a reduced deviation from e-programs, which reduces risks of participating in energy markets.

The benefit of participating on the wholesale markets is analysed for an example company that has a portfolio of multiple buildings. The company consumes 26GWh and purchases energy using forward contract types. The demand of the buildings is monitored and profiles available for analysis. The value of participating on the markets is studied by comparing the realized consumption and costs with the market performance over the same period.

Currently, the example company participates indirectly on the future markets via a broker. A 'click' contracting form is used in which the prices are fixed by the client when costs are considered to be relatively low. Per MWh, a 'profile risk' fee is paid for covering the financial risk of the broker.

In figure 43, a sample of the aggregated energy demand of some of the objects that are included in the portfolio of the example company is presented. Using the same technique as described in the 'global demand forecasting' section presented in chapter 3, a forecast of the demand can be made (see Appendix A for details of the methodology). By behaving as an 'ideal load', a lower fee could be negotiated. A saving of 1 to 1.5€/MWh is possible leading to a potential saving of approximately 0.0007€/kWh.

When the realized consumption and costs are compared to the performance of the markets (ENDEX and APX, [20, 22]), it is concluded that further cost savings is possible when

participating on the APX market. For the example company, a saving of 150.000€/yr is possible by engaging in active trade on the spot market (theoretical). The forecast of the portfolio demand as presented in figure 42 used to reduce trading risks. The flexibility in various buildings can be employed to reduce deviations from planning, reducing the risk of energy trade. Flexibility services can be offered to balance responsible parties who have such a portfolio.

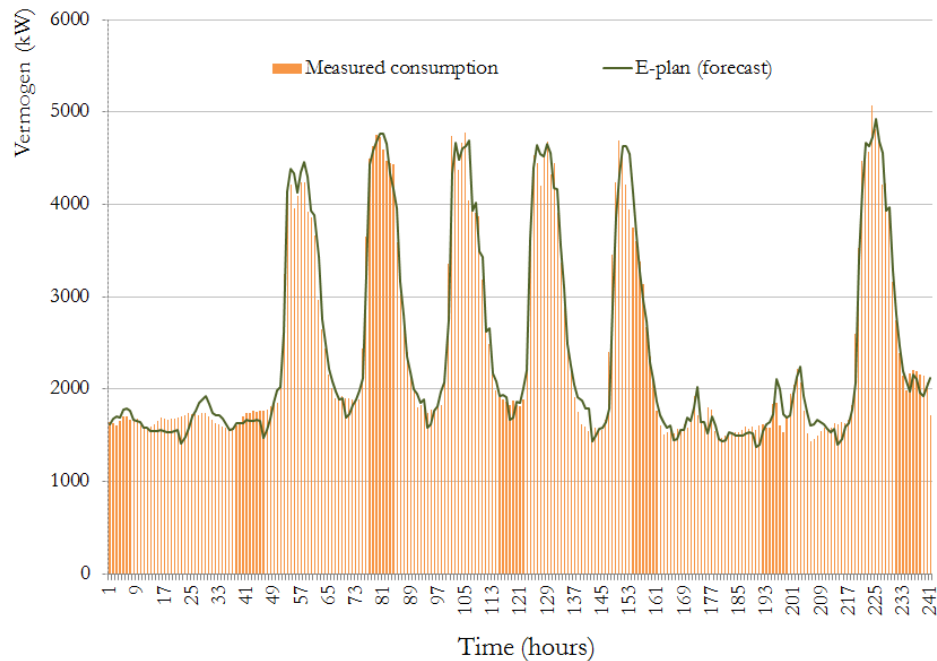

Figure 44: Forecasted and realized consumption for a portfolio of buildings.

5.3 Business Innovation

The transformation of the construction sector and integration of the energy sector in the built environment lead to increasing complexity. The technical and economic challenges for the construction sector are numerous, as new services require the integration of complex ICT and control strategies, and the complexity of the energy supply chain is introduced in the domain of building servicing. Competition is fierce and differentiation difficult. IBM [102] conducted a broad study on the influence of technological complexity. Results indicate that 60% of the CEOs experience high technical complexity now while 79% expect very high complexity in the next 5 years. And, 49% indicates that they are not prepared to handle this complexity. The results also indicate that 74% of ‘standing out companies’ pursue an iterative, ongoing strategy to incorporate new services [102].

By offering services to the energy sector, a building service provider becomes part of the energy value chain. With the transition in both the energy- and building service industries, the competition is diverse. Methods to manage transition, complexity and competitive advantage are needed. Innovation of business models and contracting forms can be a tool to manage complexity (iterative learning strategies) and to find the competitive edge [53, 90, 92, 103].

Given the complexity of the market and the state of technology, developing everything internally may not be the best option. Outsourcing can contribute to risk reduction, access to skills and thus contribute to a strategic advantage while the company focuses on core competences. For implementation of these services, BAM can partner with ICT specialists to implement agent systems. BAM can act as system integrator and contractor; orchestrating the energy management of an object (building or group of buildings) and focussing on the core business.

Chapter 6: Discussion

The priority based control framework developed in this study is able to provide in the needs of the users inside the building and to provide services for the power system.

A field test will be performed in the Eneco World Office (EWO) building in 2014. The goal of this field test is to implement and demonstrate the flexible control framework and test the business cases. The required development to be able to integrate the technological framework in the building mainly consists of interfacing and protocol design.

User comfort has been discussed in this work as a boundary condition for the priority control. Comfort schemes can be integrated in the bidding functions and/or in the optimization schemes. Comfort aspects will also be investigated in the EWO field test.

From the analysis of flexibility, it is concluded that the available flexibility is sensitive to user profiles and comfort settings. Furthermore, the capability to forecast flexibility and control consumption depends on the available sensors and actuators. A sensitivity study (e.g. Monte-Carlo analysis) can be performed to study the effect of sensor availability on the flexibility analysis. The results of such a study could be used to develop sensor requirements and analyse the added value of integrating new sensors.

In the flexibility analysis of the decentralized climate systems, conclusions are primarily based on the thermal buffering capability of the room air, which is limited. The effect of energy storage in the thermal mass of the building should be studied further. Current room climate models are based on a first-order approach, in which rooms are not coupled to each other. These models are not suitable to perform detailed analysis of thermal storage effects. This approach was chosen to reduce computational complexity and enable integration in control systems. Studies show that preheating or precooling can contribute to energy efficiency [102], it is therefore hypothesized that this can also contribute to flexibility. An important question regards in which cases it is cost effective to use the thermal mass for flexibility purposes. A dynamic, coupled simulation, could be used to analyse the effects of energy storage in the thermal mass. Such models are computationally intensive, but offer an improved analysis the long-term flexibility and building comfort.

Finally, optimization and valuation methods were demonstrated. The optimization scheme performs well for the electric vehicle and sensible storage buffer cases. To improve the results of the optimization of decentralized heating/cooling, the effects of energy losses and the chosen trajectory should be integrated in the flexibility forecast and/or optimization scheme. This requires a further development of the optimization schemes. Although this can be done by BAM, it might be better to do this in cooperation with specialized partners (like research institutes).

Chapter 7: Conclusions

The aim of this study was to develop a technological framework to enable flexibility in the energy consumption/production of office buildings.

The need for such a solution comes from both the energy and the building services sectors. The electricity system is challenged with increased demand and increased amounts of decentralized, intermittent generators. This results in imbalances, high prices and capacity problems. Buildings can be part of the solution to these challenges, as they can provide flexibility in demand. By enabling flexible control, the building can provide trading/balancing services and congestion management services to the electricity system, while user comfort can be guaranteed. Processes that either contain a thermal- or electric buffer can become sources of flexibility.

Priority based control is introduced to enable flexible control of building processes. Low priority processes can postpone energy consumption, e.g. an empty room has a low priority for consuming energy. A priority bid is generated locally based on the current process state and expected needs. This information is communicated to a market which aggregates bids of all processes and sets the priority based on the suggested optimum. A forecast of the required energy at process level is therefore communicated to a business entity which optimizes the consumption trajectory based on market signals and forecasts.

User needs are integrated in the prioritization mechanism. This mechanism ensures that processes stay within the allowed bandwidth, while providing flexibility to the power system. The integration of comfort measures is different for each process. In general the user should always be in control of its environment, and able to change set-points at will.

To enable flexible control the end user needs to be connected to the market. Therefore, signals are exchanged between the building and a partner on the electricity system (e.g. an aggregator or a program responsible party). Signals exchanged are priority bids and flexibility forecasts. The latter provides the minimum and maximum energy consumption forecasts while bid curves are exchanged with the local (virtual) market. The implementation of the technological framework in a building requires assets to exchange information bi-directionally.

The available flexibility in an office building has been analysed for the Eneco World Office, in the context of a Smart Energy Collective project. Three main sources of flexibility were investigated; decentralized climate systems, electric vehicles and a sensible buffer. These processes were chosen based on the availability and applicability in the case study building.

From the central climate systems, about 30kW of flexibility is available. For sensible storage this is about 100-150kW while electric cars offer flexible power of 400kW (44 cars). The flexibility in decentralized climate systems is low since the building features air-air heating/cooling systems, which means that the room air temperature responds quickly to changes in heating/cooling settings. The effect of storing heat in the thermal mass should however be investigated further. Results suggest that the flexibility is sensitive to energy demand and user profiles.

The economical value of the flexibility depends on the market application. For optimal purchase schemes in which energy is bought at relative cheap moments, the value is about 0.04 €/kWh. Flexibility can be used to minimize deviations from the e-program (portfolio management), this can lead to a reduction in imbalance costs. The value of peak demand reduction is 11-18 €/kW yr, depending on the contracts.

Apart from value on the electricity market side, priority based control can also create value on the building side. The control framework can contribute to building efficiency and user comfort by using energy when and where it is needed. Flexibility can also be used to reduce

risks in energy service contracting as performance in terms of comfort and cost can be guaranteed.

In the future smart grid market, BAM can act as service integrator and aggregator of flexibility from buildings. By partnering with companies specialized in ICT, BAM can focus on performance, comfort and monitoring (core activities), while partners handle implementation. Considering the potential value of smart grid services in the built environment, and the market size, it is evident that the developing smart grid market provides opportunities for BAM Techniek. The provision of flexibility services can be a valuable addition to the energy services portfolio.

Chapter 8: Recommendations for BAM

- [1] The adoption of the smart grid paradigm, and the integration of energy services in the built environment offers possibilities for enhanced service provision. BAM should pursue the opportunity for smart service energy provision in buildings.
- [2] Focus on larger office buildings with relative new building management systems to be able to provide flexibility with limited investment costs. Installations like central climate systems, heat pumps, sensible buffers etc. can provide significant flexibility.
- [3] Find specialized partners to outsource system implementation as a way to manage complexity, allowing BAM to focus on the core activities of energy management, energy performance and comfort.
- [4] Further research should focus on the sensitivity of flexibility to sensor availability and process properties, and on the use of thermal mass for flexibility purposes.
- [5] Optimization strategies and the effect of bid curves on comfort should be investigated and tested in the Smart Energy Collective Offices demonstration project.

Literature

- [1] J. Rotmans, "In het oog van de orkaan", Boxtel, the Netherlands: Eneas, 2012.
- [2] B. Asare-Bediako, P.F. Ribeiro, W.L. Kling, "Integrated energy optimization with smart home energy management systems," (ISGT Europe), 2012 *Innovative Smart Grid Technologies 3rd IEEE PES*, vol., no., pp.1,8, 14-17 Oct. 2012.
- [3] C.W. Potter, Archambault, A. Westrick, K., "Building a smarter smart grid through better renewable energy information," *Power Systems Conference and Exposition, 2009. PSCE '09. IEEE/PES*, vol., no., pp.1,5, 15-18 March 2009.
- [4] International Energy Agency, "World Energy Outlook 2009", Paris: France, 2009
- [5] V. Hamidi, K.S. Smith, R.C. Wilson, "Smart Grid technology review within the Transmission and Distribution sector", *Innovative Smart Grid Technologies Conference Europe (ISGT Europe)*, 2010 IEEE PES, vol., no., pp.1,8, 11-13 Oct. 2010.
- [6] G. Krajacic et. al., "Planning for a 100% independent energy system based on smart energy storage for integration of renewable and CO2 emissions reduction", *Applied Thermal Engineering*, vol.pp. 31 2073-2083, 2011.
- [7] F. Rahimi, A.Ipakchi, "Overview of Demand Response under the Smart Grid and Market paradigms," *Innovative Smart Grid Technologies (ISGT) 2010*, vol., no., pp.1,7, 19-21 Jan. 2010.
- [8] J.K. Kok., "The PowerMatcher, Smart Coordination for the Smart Electricity Grid", PhD. Thesis, Vrije Universiteit Amsterdam, 2013.
- [9] T. Dril, J. Gerdes, S. Marbus, et Al., "Energie trends 2012", ECN, the Netherlands, 2012.
- [10] Smart Energy Collective, Internet: <http://www.smartenergycollective.com/>, updated okt-2013 [Okt. 13, 2013].
- [11] P.F. Ribeiro, H. Polinder, M.J. Verkerk, "Planning and Designing Smart Grids: Philosophical considerations", *IEEE Technology and Society Magazine*, 2012.
- [12] E.J Coster, M.A. Myrzik, B. Kruimer, et al. "Integration Issues of Distributed Generation in Distribution Grids", *IEEE proceedings*, vol 99. No 1., 2011
- [13] EPA's Green Building Workgroup, "Buildings and their Impact on the Environment: A Statistical Summary", Available: <http://www.epa.gov/greenbuilding/pubs/gbstats.pdf>, 2009.
- [14] Senternovem, "Databank", Internet: <http://senternovem.databank.nl/>, Rijksdienst voor Ondernemend Nederland, updated Dec. 2013 [Dec. 2013].
- [15] Centraal Bureau voor de Statistiek (CBS), "StatLine databank", Internet: <http://statline.cbs.nl/statweb/>, updated: Dec. 2013 [Dec. 2013].
- [16] V. Hamidi, K.S. Smith, R.C. Wilson, "Smart Grid technology review within the Transmission and Distribution sector", *Innovative Smart Grid Technologies Conference Europe (ISGT Europe)*, 2010, IEEE PES, vol., no., pp.1,8, 11-13 Oct. 2010.
- [17] MKBei.nl, "Nederland stevent af op catastrofale energieproblemen" (interview with Twente University), Internet: <http://www.mkbei.nl/nieuws/nederland-stevent-af-op-catastrofale-energieproblemen/>, updated: feb-2013 [Okt, 2013].
- [18] M. Nicolosi, "Wind power integration and power system flexibility—An empirical analysis of extreme events in Germany under the new negative price regime", *Energy Policy*, Volume 38, Issue 11, Pages 7257-7268, 2010.
- [19] I. Lampropoulos, J. Frunt., F.A. Nobel, et. Al., "Analysis of the market-based service provision for operating reserves in the Netherlands", European Energy Market (EEM), 2012 *9th International Conference on the*, vol., no., pp.1,8, 10-12 May 2012.
- [20] APX Group, "Market Results", APX-ENDEX, Internet: www.apxgroup.com/, updated: Dec. 2013 [Dec. 2013].
- [21] A. Kieft, E. Niesten, F. Alkema et. al., "Het energiemarktmodel", Smart Grids voor iedereen (WP2.1), Utrecht, 2013.

- [22] TenneT, "Data systeem & Transport; Exporteer data", Internet: <http://www.tennet.org/bedrijfsvoering/ExporteerData.aspx>, updated: Dec. 2013 [Dec. 2013].
- [23] Cofely, "De Nederlandse Energiemarkt in Perspectief", available: [http://www.gdfsuez.nl/~media/GdfSuez/Standpunten/Ontwikkeling_%20elektriciteit smarkt.ashx](http://www.gdfsuez.nl/~media/GdfSuez/Standpunten/Ontwikkeling_%20elektriciteit%20smarkt.ashx), GDF Suez, the Netherlands, 2012.
- [24] ConsuWijzer, "Consument krijgt lagere energierekening", Internet: <http://www.consuwijzer.nl/nieuws/consument-krijgt-lagere-energierekening>, updated: Okt. 2013 [Nov, 2013].
- [25] Rijksoverheid (Dutch Government), "Electrischiteitswet 1998", available: http://wetten.overheid.nl/BWBR0009755/Aanhef/geldigheidsdatum_28-10-2013, Sept. 2013 [Okt, 2013].
- [26] K. El Bakari, W.L. Kling, "Development and operation of virtual power plant system," *Innovative Smart Grid Technologies (ISGT Europe), 2nd IEEE PES International Conference and Exhibition on*, vol., no., pp.1,5, 5-7 Dec. 2011.
- [27] F.D.J. Nieuwenhout, A.J. Brand, S.M. Lensink, "Profiel- en onbalanskosten van windenergie in 2012", *ECN Beleidsstudies*, ECN-N—13-016, 2013.
- [28] R. Vreeken, "The developed energy service company markets in the European union", MSc. Thesis; Sustainable Development – Utrecht University, Utrecht, 2012.
- [29] S. de Boer, "Views on the emerging Dutch ESCO market: Can it become successful", MSc. Thesis, Rabobank, Utrecht, 2011.
- [30] T. Adkinzon, "Building automation & controls, what's new & what will the future bring", Presentation, T. Atkinson Electronics, available: http://utahashrae.org/PDFs/BuildingAutomation_Controls.pdf, 2012.
- [31] B. Asare-Bediako, W.L. Kling, P.F. Ribeiro, "Home energy management systems: Evolution, trends and frameworks", *Universities Power Engineering Conference (UPEC), 2012 47th International*, vol., no., pp.1,5, 4-7 Sept. 2012.
- [32] B. Asare-Bediako, W.L. Kling, P.F. Ribeiro, "Integrated energy optimization with smart home energy management systems," *Innovative Smart Grid Technologies (ISGT Europe), 2012 3rd IEEE PES International Conference and Exhibition on*, vol., no., pp.1,8, 14-17 Oct. 2012, 2012.
- [33] S. McArthur, E. Davidson, V. Catterson, et. al. "Multi-Agent Systems for power engineering applications- Part I: Concepts, Approaches, and Technical Challenges", *IEEE Transactions on Power Systems*, vol. 22, no. 4, pp. 1743-1752, 2007.
- [34] S. Heragu, R. J. Graves, B. Kim and A. S. Onge, "Intelligent Agent Based Framework for Manufacturing Systems Control", *IEEE Transactions on Systems, Man, And Cybernetics- Part A: Systems and Humans*, vol. 32, no. 5, pp. 560-573, 2002.
- [35] M. Pipattanasomporn, H. Feroze and S. Rahman, "Multi-Agent Systems in a Distributed Smart Grid: Design and Implementation", *Power Systems Conference and Exposition*, Seattle, USA, 2009.
- [36] L. Klein, J. Kwak, G. Kavulya, G. et al. "Coordinating occupant behaviour for building energy and comfort management using multi- agent systems", *Automation in Construction* 22, 525-536, Elsevier, 2011.
- [37] L. Wang, Z. Wans, R. Yang, "Intelligent Multiagent Control System for Energy and Comfort Management in Smart and sustainable buildings", *IEEE Smart Grid transactions*, Volume 3, issue 2, 2012.
- [38] L. Pennings, G. Boxem, M.A. van Houten, W. Zeiler, "Multi agent system to optimize comfort and energy flow in the build environment", *Proceeding 10th International Conference for Enhanced Building Operations*; 1. - p. 1-5, the Netherlands, 2010.
- [39] F. Oldewurtel, A. Parisio, C.N. Jonges, et. Al. "Use of model predictive control an weather forecasts for energy efficient building climate control", *Energy And Building* 45 15-27, 2012.

- [40] Y. Ma, A. Kelman, A. Daly, F. Borrelli, F. "Predictive Control for Energy Efficient Buildings with Thermal Storage: Modeling, Stimulation, and Experiments," *Control Systems, IEEE*, vol.32, no.1, pp.44,64, Feb. 2012.
- [41] M.P.F. Hommelberg, B.J. van der Velde, C.J. Warmer, et. al. "A novel architecture for real-time operation of multi-agent based coordination of demand and supply", *Power and Energy Society General Meeting - Conversion and Delivery of Electrical Energy in the 21st Century*, 2008 IEEE, vol., no., pp.1,5, 20-24 July 2008.
- [42] I. Lampropoulos, N. Baghina, W.L. Kling, P.F. Ribeiro, "A Predictive Control Scheme for Real-Time Demand Response Applications", *Smart Grid, IEEE Transactions on*, vol.4, no.4, pp.2049,2060, Dec. 2013.
- [43] A. Mohsenian-Rad, V.W.S. Wong, J. Jatskevich, et al. "Autonomous Demand Side Management Based on Game-Theoretic Energy Consumption Scheduling for the Future Smart Grid", *Smart Grid, IEEE Transactions on*, vol.1, no.3, pp.320,331, Dec. 2010.
- [44] TNO, "PowerMatcher Information brochure", available at: https://www.tno.nl/downloads/brochure_powermatcher.pdf, 2012.
- [45] J.K. Kok., C.J. Warmer, I.G. Kamphuis, "PowerMatcher: multiagent control in the electricity infrastructure", *Proceedings of the fourth international joint conference on Autonomous agents and multiagent systems*, ISBN: 1-59593-093-0, 2005.
- [46] J.K. Kok, B. Roossien, P.MaxDougall, et al. "Dynamic Pricing by Scalable Energy Management Systems – Field Experiences and Simulation Results using PowerMatcher", *IEEE PES General meeting*, 2012.
- [47] N. Leemput, B. Claessens, J. van Roy, et al. "A case Study of Coordinated Electric Vehicle Charging for Peak Shaveing on a Low Voltage Grid", *IEEE*, available at: <https://lirias.kuleuven.be/bitstream/123456789/367125/1/PID2450949.pdf>.
- [48] EERA, D.2.1, "Overview of simulation tools for Smart Grids", page 42, *EERA Joint Programme on Smart Grids*, 2013.
- [49] J. van Roy, R. Salenbien, D. Vanhoudt, et al. "Thermal and Electrical Cover Factors: Definition and Application for Net-Zero Energy Buildings", KU Leuven/ Vito, available at: https://lirias.kuleuven.be/bitstream/123456789/403431/1/Paper_JuanVanRoy.pdf.
- [50] G.K. Schaeffer, C.J. Warmer, I.G. Kamphuis, et. Al. "Field Tests Applying Multi-Agent Technology for Distributed Control: Virtual Power Plants and Wind Energy", ECN, *CRIS Workshop*, 2006.
- [51] K. El Bakari, J.M.A. Myrzik, W.L. Kling, "Prospects of a virtual power plant to control a cluster of distributed generation and renewable energy sources", *Universities Power Engineering Conference (UPEC), 2009 Proceedings of the 44th International*, vol., no., pp.1,5, 1-4 Sept. 2009.
- [52] K.E. Bakari, W.L. Kling, "Virtual power plants: An answer to increasing distributed generation", *Innovative Smart Grid Technologies Conference Europe (ISGT Europe)*, 2010 IEEE PES, vol., no., pp.1,6, 11-13 Oct. 2010.
- [53] DNV KEMA, "Leveraging Smart Grid Data", White Paper on the applications and uses for smart grid data, 2013.
- [54] European Union, "Horizon 2020", Internet: <http://ec.europa.eu/programmes/horizon2020/>, updated: Dec 2013 [Nov. 2013].
- [55] NL Agency, "IA Special, innovation on Smart Grids and energy storage", Ministry of Economic Affairs, NL EVD International, ISSN 1572-6045, the Hague, the Netherlands, 2012.
- [56] Topsectoren, "Topsectoren Nederland", Internet; <http://topsectoren.nl/>, updated: Dec. 2013 [Dec. 2013].
- [57] Top Team Energy, "Innovation Contracts; Smart Grids, Headlines of public private partnership and, Innovation Agenda 2012", 2012.
- [58] Dutch Organisation for Scientific Research (NOW), "programme smart energy systems", Internet: <http://www.nwo.nl/en/research-and-results/programmes/smart+energy+systems>, updated: Dec. 2013 [Dec. 2013].

- [59] NL Agency, "Intelligent warmtenet campus TU Delft", *Proeftuinen intelligente netten*, Ministry of Economic Affairs, Utrecht, The Netherlands, 2013.
- [60] NL Agency, "Couperus Smart Grid; Experimenting with Intelligent Networks", *Proeftuinen intelligente netten*, Ministry of Economic Affairs, Agriculture and Innovation, Utrecht, the Netherlands, 2012.
- [61] NL Agency, "Modulair Intelligent Energienetwerk voor bedrijventerreinen (Modiennet) ", *Proeftuinen intelligente netten*, Ministry of Economic Affairs, Utrecht, the Netherlands, 2013.
- [62] "De Wijk van Morgen", Internet: <http://www.dewijkvanmorgen.nl/index.jsp>, updated: Dec. 2013 [Dec. 2013].
- [63] NL Agency, "Cloud power Texel", *Proeftuinen intelligente netten*, Ministry of Economic Affairs, Utrecht, the Netherlands, 2013.
- [64] NL Agency, "Your Energy Moment; Smart Grid with the Consumer", *Proeftuinen intelligente netten*, Ministry of Economic Affairs, Utrecht, the Netherlands, 2013.
- [65] E- harbours, "point of departure 2011", The Inter-reg IVB North Sea Region Programme, available: <http://eharbours.eu/>, 2011.
- [66] Provincie Groningen, "Veenkoloniën: vernieuwende proeftuin voor klimaat en energie", Internet: <http://www.provinciegroningen.nl/uitvoering/klimaat-en-energie/hotspot-veenkolonien/>, updated: Nov. 2013 [Dec. 2013].
- [67] Meppel energie, "Meppel energie", Internet: <http://www.meppelenergie.nl/>, updated: Dec. 2013, updated: Nov. 2013 [Dec. 2013].
- [68] Siemens, "M/490 Reference Architecture WG", framework for smart grid architecture, available: <http://www.pointview.com/data/files/1/473/2185.pdf>, 2012
- [69] B.R.M. Kingma, L. Schellen, A.J.H. Frijns, et al. "Thermal Sensation: a mathematical model based on neurophysiology", *indoor air* 22,253-262, the Netherlands, 2011
- [70] L.A. Hurtado, W. Zeiler, "Building Energy Management Systems – Optimization of comfort and Energy use", Eindhoven University of Technology, 2014.
- [71] J. Grabe and S. Winter., "The correlation between PMV and dissatisfaction on the basis of the ASHRAE and the McIntyre scale—Towards an improved concept of dissatisfaction", *Int. Soc. Built Environ., Tech.* Available: <http://ibe.sagepub.com/content/17/2/103.full>., 2007.
- [72] B. Olesen and G. Brager. "A better way to predict comfort: The new ASHRAE Standard" 55-2004. *ASHRAE*. Available: <http://escholarship.org/uc/item/2m34683k.pdf>, 2004.
- [73] European Union, "Data Protection Directive", EU Department of Justice, available: <http://ec.europa.eu/justice/data-protection/>, updated: Sept. 2013.
- [74] W. Zeiler, O. Savanovic, G. Boxem, et al. "Integral Design of Sustainable Energy into buildings: From Synergy to Flexergy", *PLEA 2008 – 25th Conference on Passive and Low Energy Architecture*, Dublin, 2008.
- [75] S. Vandael, B. Claessen, M.P.F. Hommelberg, "A Scalable Three-Step Approach for Demand Side Management for Plug-in Hybrid Vehicles", *IEEE Transactions on Smart Grid*, Vol. 4, No 2, 2013.
- [76] S. Dashupta, C.H. Papadimitriou, U.V. Vazirani, "Chapters 6; dynamic programming", in: *Algorithms*, book available via Berkeley University, 2006.
- [77] A. Nouredine, R. Rouvoy, L. Seinturier, "A review of middleware approaches for energy management in distributed environments", *Software – Practice and Experience*, Wiley, 2012.
- [78] BACnet, "BACnet", *ASHRAE SSPC 135*, available: <http://www.bacnet.org/>, 2013
- [79] Echelon, "LonWorks", Internet: <http://www.echelon.com/technology/lonworks/>, updated: Dec. 2013 [Dec. 2013].
- [80] KNX, "KNX standard", Internet: <http://www.knx.org/>, updated: Dec. 2013 [Dec. 2013].
- [81] Zigbee Alliance, "ZigBee", Internet: <http://www.zigbee.org/>, updated: Dec. 2013 [Dec. 2013].

- [82] M. Brink, "Future- proof platforms for aging –in-place", PhD. Thesis, Eindhoven University of Technology, the Netherlands, 2013.
- [83] P. Wolf. et. al. "OpenAAL – the open source middleware for ambiend- assisted living (AAL) ", *AALiance conference*, Malaga, Spain, 2010.
- [84] OpenADR alliance, "OpenADR primer", available: <https://openadr.memberclicks.net/>, 2013.
- [85] Eclips foundation, "Eclips", Internet: <http://www.eclipse.org/org/foundation/>, updated: Dec. 2013 [Dec. 2013].
- [86] Toyota, "Prius Battery Specification", <http://www.toyotapriusbattery.com/> Jan 2013 [Dec 2013].
- [87] GM Volt, "Chevy Volt specifications", Internet: <http://gm-volt.com/full-specifications/> Nov. 2013 [Dec. 2013].
- [88] Greenbang, "Eight definitions of smart buildings", Internet: http://www.greenbang.com/from-inspired-to-awful-8-definitions-of-smart-buildings_18078.html, May 2013 [Dec. 2013].
- [89] V. Giordano, S. Bossart, "Assessing Smart Grid Benefits and Impacts: EU and U.S. Initiatives", European Commission Joint Research Centre, 2012
- [90] A. Booth, "The Smart Grid Opportunity For Solution Providers", *McKinsey on Smart Grid*, McKinsey, 2010.
- [91] N. Allen, S. Hazlett, M. Nerlinger, "Smart Grid: The Next Infrastructure Revolution", *Clean Energy*, Morgan Stanley, 2009
- [92] A. Christensen, J. Green, R. Roberts, "Maximizing value from Smart Grids", *McKinsey on Smart Grid*, McKinsey, 2010.
- [93] NL Agency, "Who is Who; players in the Dutch smart-grid sector", Ministry of Economic Affairs, Agriculture and Innovation, Utrecht, the Netherlands, 2013.
- [94] European Union, "Commission recommendation of 9 March 2012, on preparations for the roll-out of smart metering systems", 2012/147/EU, *Official Journal of the European Union*, 2012.
- [95] Rijksoverheid (Dutch Government), "Leegstand kantoren", available: <http://www.rijksoverheid.nl/onderwerpen/leegstand-kantoren>, 2013.
- [96] Vastgoedmarkt.nl, "Woningtekort loopt op", Internet: <http://www.vastgoedmarkt.nl/nieuws/2012/08/29/Woningtekort-loopt-op-naar>, updated: Apr 2013 [Dec. 2013] .
- [97] A. Balvers, S. van Uffelen, "Dutch Green Building Benchmark 2012", DGBC, 2012
- [98] R.L. Bak, "Kantoren in cijfers 2012", NVM, available: www.nvm.nl, 2013
- [99] Facility management magazine, "green lease", Internet: <http://www.fmm.nl/>, updated: Apr 2013 [Nov. 2013] .
- [100] Vastgoedjournaal, "tijdelijk duurzaamhuisvesten", Internet: <http://www.vastgoedjournaal.nl/>, updated: May 2013 [Nov. 2013] .
- [101] Elkhuisen, B. & Rooijackers, E. "Duurzaam beheer van gebouwen", *TVVL*, jan-2008, the Netherlands, 2008
- [102] IBM, "Capitalizing on Complexity", *Insights from the Global Chief Executive (CEO) Study*, IBM, 2010
- [103] P. Senge, "The learning organization", Internet: <http://infed.org/mobi/peter-senge-and-the-learning-organization/>, updated: Apr. 2013 [Nov. 2013] .
- [104] A. Mellit, Soteris A. Kalogiroub, Artificial intelligence techniques for photovoltaic applications: A review, *Progress in Energy and Combustion Science* 34 (2008) 574–632, 2008
- [105] S.C. Sofuoglu, "Application of artificial neural networks to predict prevalence of building-related symptoms in office building", *Building and Environment* 43 (2008) 1121-1126, Turkey, 2007.

Appendix A: Global demand forecasting

The prediction module is a separate part in the priority control concept (see figure A1). In order to participate on the market, a day-ahead planning of the energy consumption per hour is required. The purpose of the consumption- production prediction module, introduced in this appendix is to make such predictions on building premises scale for the longer term.

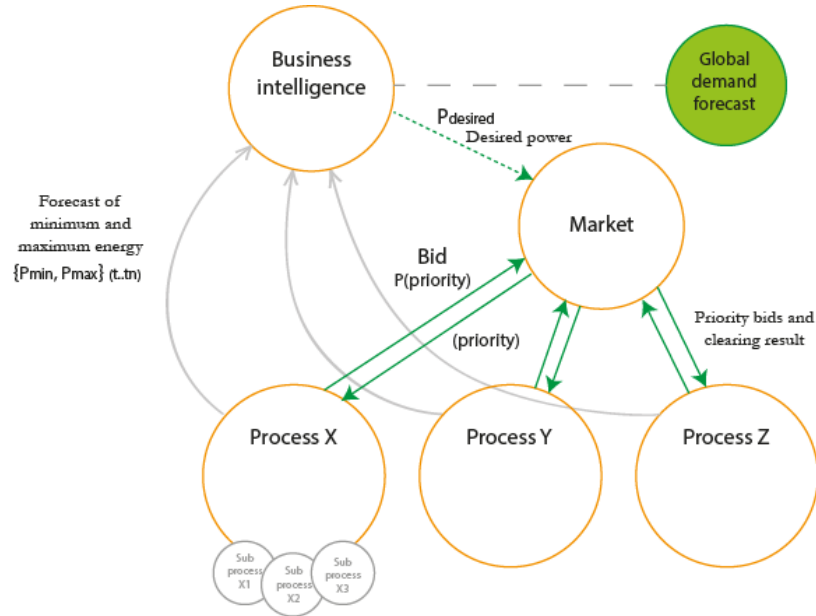

Figure A1: Forecasting module in relation to the other components in the priority based control framework.

Prediction module

The module can be developed separately of other modules and new versions can be ‘plugged in’. In order to standardize forecasting module design for similar projects, the following design process is suggested (figure A2) consisting of typical system implementation process (plan, architecture/- system design, implementation, testing and evaluation). The focus of this appendix is on the implantation and evaluation.

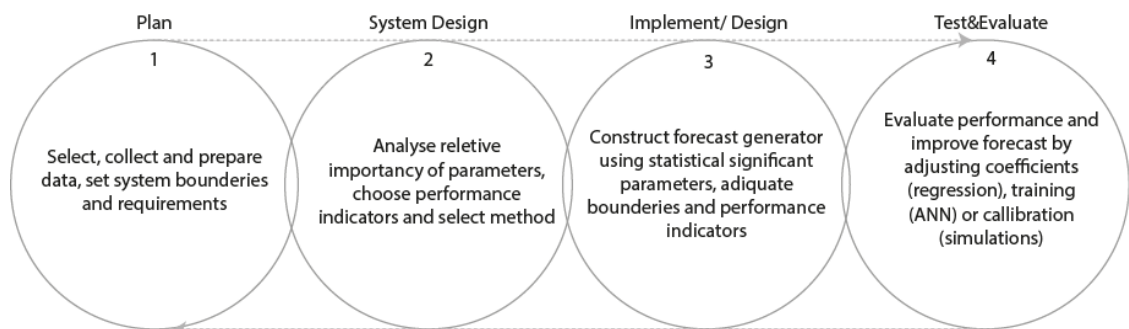

Figure A2: Module design and implementation process

In the planning phase, requirements and available data have been determined. Sensitivity analysis was used to determine the most relevant parameters that have a significant influence on forecasting results. The forecasting will be based on those parameters.

Methods

Forecasting can be based on computational simulation of processes or on statistical methods, both of which can be data-driven. A building is a complex environment and users have a major influence on energy consumption. It is therefore difficult to provide accurate forecast using building simulation models, in particular for the longer term. Forecasts on building (or area) scale based on aggregated data can be more accurate since errors in the prediction of individual processes are levelled out statistically (aggregated statistical error < individual error). The spatial resolution is less relevant since the forecast is on the scale of building premises; detailed information is thus not required. A statistical approach will be taken given that historical energy consumption data and weather data is available which may be assumed.

Using (linear) regression and/or artificial neural network methods, forecasts can be made based on historical data and external information like weather forecasts. Energy consumption patterns can for instance be related to weather predictions and historical consumption measurements. The advantage of this method is that limited knowledge about the underlying processes is required to be able to make a forecast, while the forecast methods can be adjusted when more data is available and are self-learning.

Artificial neural networks

Artificial neural networks (ANN) are capable of handling complex non-linear relations between input and output. Similar to biological ‘calculative systems’ (human brain), ANN’s work based on neurons. Figure A3 shows a schematic overview of the mathematical functioning of an ANN. A neuron which is basically a cell which sends out an impulse based on the sum of the input signals; when a threshold is reached, the neuronal will fire (activation function z in figure A2). An ANN needs to be trained, in order to ‘learn’ how to relate input to output. Neurons are connected, and connections are weighted based on the network training (ω and θ in figure A2). Also the threshold at which the neurons fire can depend on training. Further information about the functioning of ANN can be found in, for example, in [104] and [105]. One of the strengths of ANN is the ability to link seemingly unrelated effects, and/or predicting parameters based on seemingly unrelated patterns (complex, non-linear relations).

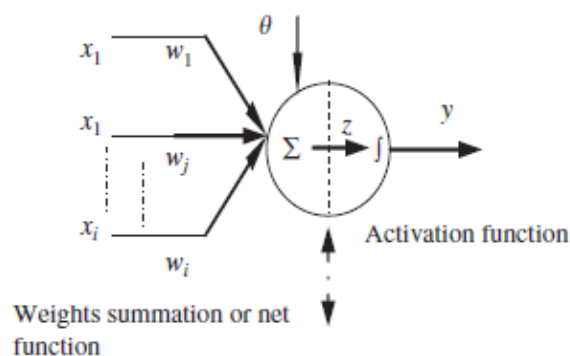

Figure A3: Schematic representation of a neural network node. Input from other neurons is accumulated, the activation function will ‘fire’ based on this summation of weighted (ω) inputs, transfer function z and bias θ . [108]

The ANN can then be viewed as a black box. By training, weights and thresholds will be adjusted to reduce the error. Based on error ε_i in each prediction, the rooted mean squared error ($RMS\varepsilon_i$) is minimized.

Forecasting module requirements

General requirements for the forecast are included in table A1.

Table A1: General requirements for forecasting module

Goal	Building premises scale electrical energy consumption forecast to be used for planning purposes.
Forecast horizon	14 days
Time- resolution	<= 60 min.
Spatial-resolution	Aggregated electric energy consumption
Accuracy	High for day- ahead, but not otherwise specified. As a general rule the error should be less than available flexibility.
Update frequency	<= 60 min.
Performance indicator	RMSE \in CL ₉₀ (root mean squatted error with a 90% confidence level)
Interface Class (output) for communicating with other modules	<div style="border: 1px solid black; padding: 5px; width: fit-content; margin: 0 auto;"> <p style="text-align: center; margin: 0;">iForecast</p> <p style="margin: 0;">-P1..Pi : float</p> <p style="margin: 0;">-e : float</p> <p style="margin: 0;">-t : double</p> </div> <p style="text-align: center; margin-top: 10px;">Class containing forecasted electrical powers P_{1..} P_i, error ‘e’ and timestamp t</p>
Other	Should be scalable, easy to maintain and capable of learning.

Demonstration

For demonstration purposes, an ANN implantation is implemented in Excel. The network is constructed according to specifications in table A2. Input signals are available from energy measurements and external data source (e.g. weather information).The network was trained for one hour. The performance of the network is included in table A3, the error distribution is included in figure A4. Forecasting results presented as time series are included in the report.

The network performs well, the error is <30% for 90% of the time. Also in comparison to regression analysis, forecasting performance is good. The ANN can be improved by training the network longer, having more training data (multi- year), and by alternating the network design in terms of neuron layout.

It should be pointed out that training data was also used for verification, this means that the network is performing very well within the training data. When a real forecast is made, accuracy will decrease as function of the forecast horizon. Including more data sources and/or higher quality data sources can improve the accuracy. By training the networks regularly, performance can be improved constantly. Figure A5 provides a possible training scheme.

Table A2: Artificial neural network specification

Layers	3
Neurons in hidden layer	15
Activation function	Sigmoid: $O_f(\bar{x}, \bar{w}) = \frac{1}{1+e^{A(\bar{x}, \bar{w})}}$
Bias	Yes
Training goal	Minimize average square root error ($RMS\epsilon_i$)
Input	Time (day of the week, working day yes/no), Ambient temperature, Irradiation, Consumption history (6 samples of 24 hours in the past).
Training data	Measured electrical energy

Table A3: Implemented artificial neural network performance

Coefficient of determination (R^2)	0,950
90% Confidence interval error	20-30%
Average relative error	-0,3%

Automated learning

By training the network regularly, forecasting results can be improved based on measured values. This also makes the forecasting module capable integrating new situation, a model based approach would require redesign. An example of a learning scheme is included in figure A3. Measured values are compared to the forecast output, the error can be minimized by engaging in training sessions automatically.

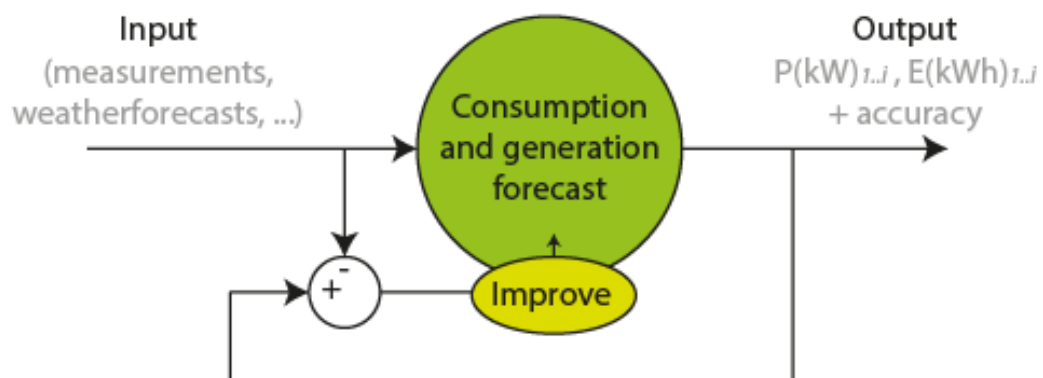

Figure A4: Automated learning scheme

Module implementation

The possible module class diagram is included in figure A6.

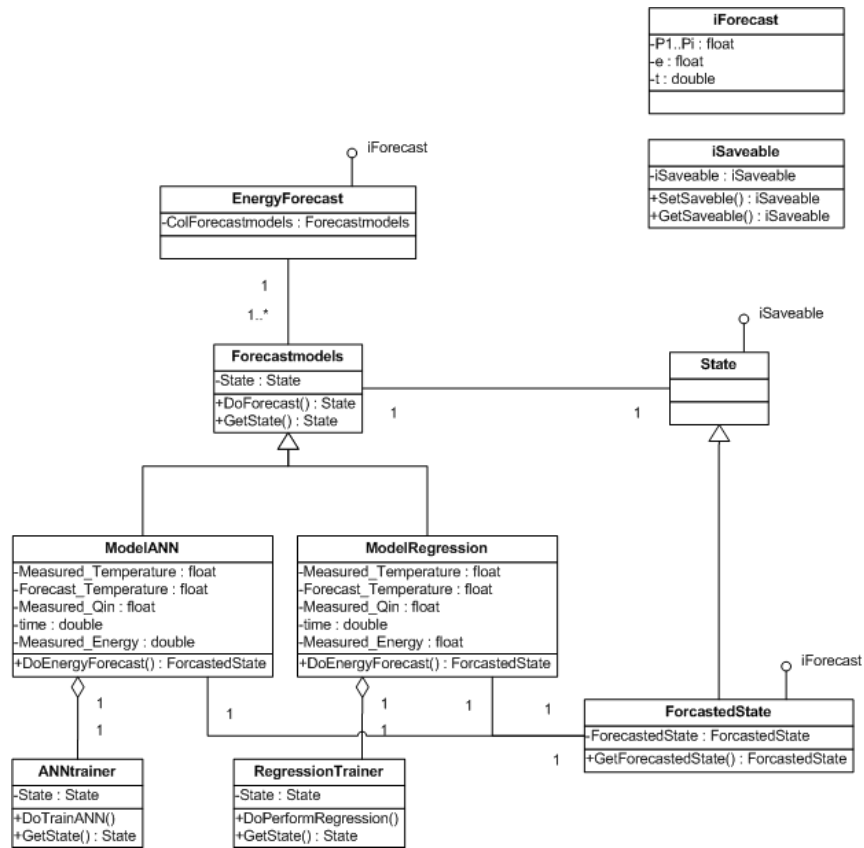

Figure A5: Energy forecast class diagram including interfaces (can be integrated with other modules)

Appendix B: Process models

The local process is where the energy is actually consumed and where control signals are applied. There are two functions that are performed for each process; forecasting of future flexibility and real-time control, both of which can be handled by an agent.

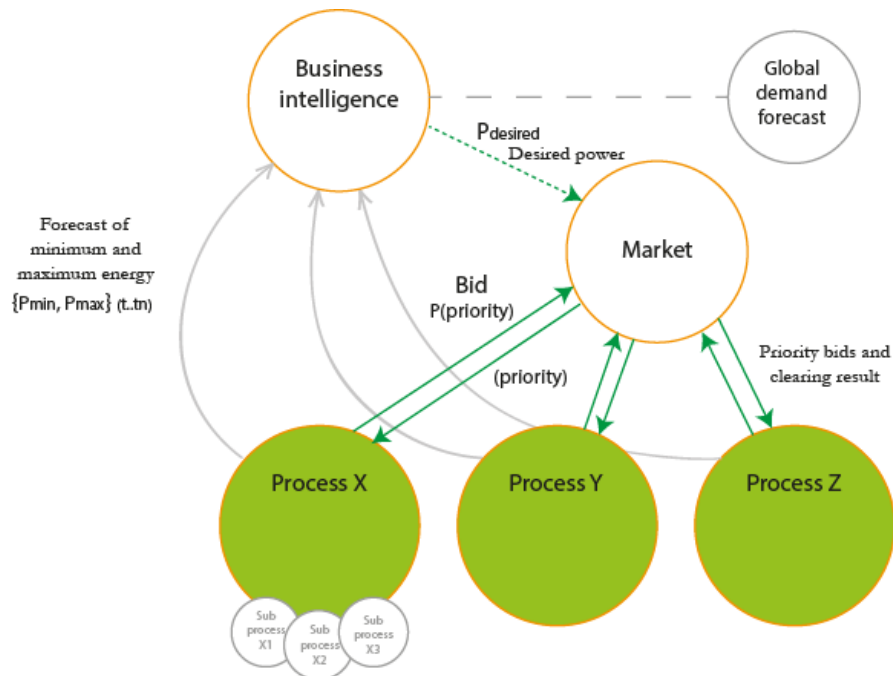

Figure B1: Processes interacting with other components of priority based control framework.

The local process

The 'local process' is a component providing a service in the building. A local process can, for example, be an electric car, a heat pump, storage vessel, fan or a room including heating/cooling systems. Real-time control function consists of creating bid functions based on the current and anticipated states, matching the central priority to the bid functions, and translating the allowed consumption into a control signal. The forecast function consists of forecasting minimum and maximum power consumptions/ generation over a longer horizon. In order to these functions, the local process needs to be captured in a process models. Models can also be used for flexibility analysis during the design phase. For the design of new modules the following scheme is proposed. In this appendix, the focus is in the planning and system design phases.

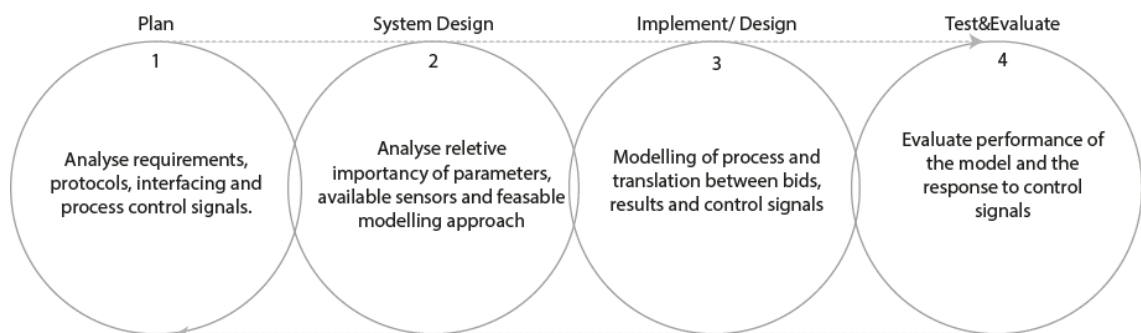

Figure B2: Process model design and implementation process.

Simulations of the expected future state are performed using the process models and available data on the current and expected values of environmental parameters. Comfort is the guaranteed at all times so the minimum required energy is depending on the minimum service level required in the upcoming control periods. This is depending on user settings, building control settings and installation settings

General specification

The purpose of the current module is to determine the value of flexibility and the suggestion of an optimal power so flexibility can be employed to maximum effect. A general description of functionality/ requirements is provided in table B1.

Table B1: General requirements for process models.

Goal	Provide flexibility for the upcoming PTU's	Provide real- time control and bidding						
Forecast horizon	Up to 14 days	Up to one PTU						
Time- resolution	1 PTU	Up to one PTU						
Spatial-resolution	Process specific electric energy consumption	Process specific electric energy consumption						
Accuracy	High for day- ahead, but not otherwise specified.	High for next control cycle						
Update frequency	≤ 60 min.	60 seconds						
Performance indicator	Predicted flexibility versus realized flexibility	Required energy versus resulting room state						
Interface Class (out) for communicating with other modules	<table border="1" style="margin-left: auto; margin-right: auto;"> <tr><td style="text-align: center;">iFlex</td></tr> <tr><td style="text-align: center;">-[Pmin, Pmax] : float</td></tr> <tr><td> </td></tr> </table>	iFlex	-[Pmin, Pmax] : float		<table border="1" style="margin-left: auto; margin-right: auto;"> <tr><td style="text-align: center;">iBid</td></tr> <tr><td style="text-align: center;">-[P, priority] : float</td></tr> <tr><td> </td></tr> </table>	iBid	-[P, priority] : float	
iFlex								
-[Pmin, Pmax] : float								
iBid								
-[P, priority] : float								
Other	Should be scalable, easy to maintain and flexible (adjustable to new situations)							

Available process models

Available process models describe: room climate, electric vehicle charging and sensible thermal buffering in a storage vessel.

Decentralized climate control

Decentralized climate control is applied for the control of the local climate. Depending on the specific building installations; the temperature of spaces is maintained using radiators, cooling ceiling, fan coils etc. By allowing a temperature variation around the set-point provided by the user, flexibility in energy demand can be enabled.

Simulation models are used to determine the future state of the room depending on the current states and control actions. Hence, the flexible control of the room climate is a type of model predictive control. The model is based on the energy balance the room or zone (see figure B3). The model assumes heat is provided with fan coil units. The most significant contributors to the local climate are included in the energy balance. The simulation model is based on a first-order derivative of the physics describing heat exchange, storage and other effects. The model is solved quasi-statically to find the room temperature and update the boundaries. This approach is chosen to guarantee computational simplicity which contributes to scalability.

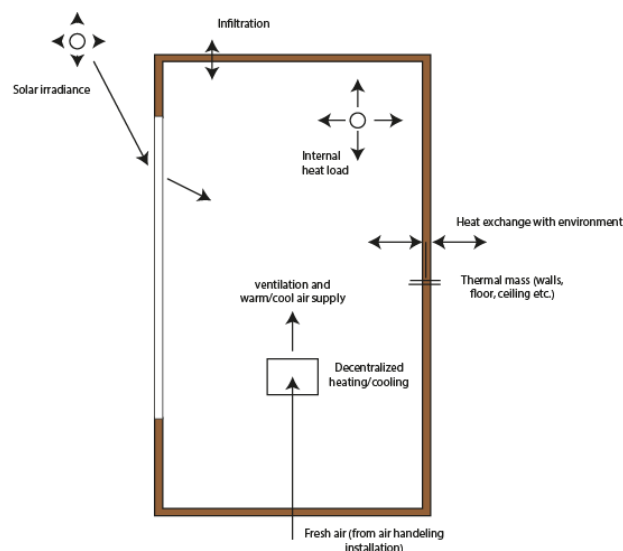

Figure B3: Schematic representation of a room, used as basis for model development.

Comparison to ESP-r

For the purpose of demonstrating the performance of the decentralized climate models, the results of the model were compared to building simulation environment ESP-r (ESP-r, 11.11-6935, 2012). A model was made in ESP-r and simulated with the same input parameters, user profiles and a similar climate profile. The room is 100m², heat is provided through ventilation. A comparison between the first-order approach developed here and ESP-r results is included in figure B4. From the results, it can be concluded that the decentralized climate process model performs well. The temperatures show a deviation in the afternoon, when there is solar irradiance which is not present in the ESP-r model (not taken into account). The total energy consumption is also similar, although the decentralized climate process model consumes less energy when there is solar irradiation.

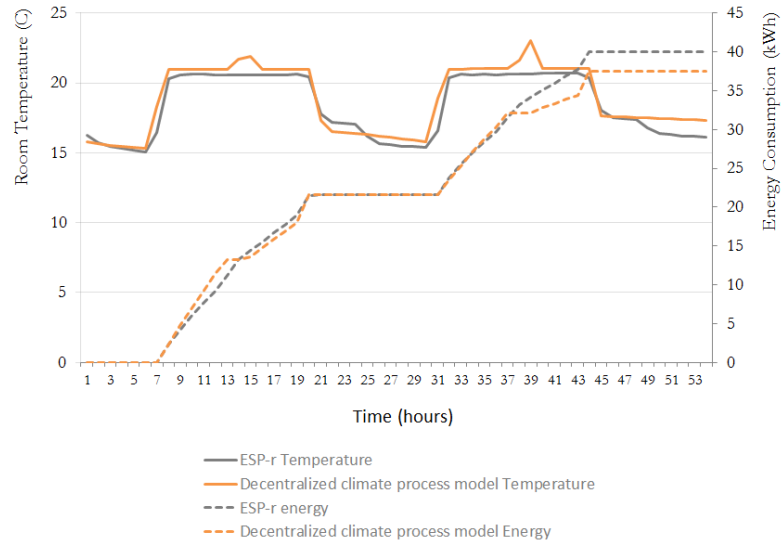

Figure B4: Comparison of ESP-r and decentralized process model results for 2 days in winter.

Data sources

In table B2 potential data sources are included. When no data is available, estimated profiles can be used. Model accuracy is increased with more data.

Table B2; Data sources for decentralized climate process model.

	Data sources (sensors)	Building level sources (supporting or alternative)	Alternative in case no sensors present
User presence	Presence, CO2, room agenda (Outlook/SAP)	Building access/security system	Assumed profiles based on type of zone, number of employees, office hours etc.
Temperature	Thermostat, thermometers	Zone set-point or central set-point (reduced resolution)	
Lighting	(dim)switch, measured energy consumption, lux meter, daylight sensors	Central switch/control	Assumed lighting profiles based on type of lights, system settings and armatures
Heating/ Cooling plant	Temperature sensors; air, water. Mass flow air/ water (trough installation).	-	Central set-points
Accumulation	Temperature sensors in walls and floors	-	Measuring temperature in-/decrease when no one is present to determine RC
Ventilation	Flow meters, local fan rpm, electricity consumption of fans, valve settings, CO2 sensors	Central setting, fan flow rpm, electricity consumption, settings	-

Electric vehicles

Electric vehicles (EV) like electric bikes and cars are a direct source of electrical flexibility. The charging of a fleet of EV's is not without consequence for the electricity infrastructure. If there are multiple EV's which are plugged-in within a short amount of time (e.g. when employees arrive at work), peaks in power demand occur causing congestion on the (local) grid.

Process model for electric vehicle charging

The model for charging/discharging of the battery is based on the applied power which influences the state of charge (SOC) of the battery. Charge loss as a function of time and/or temperature is not included in the current models, however the current models can easily be expanded. An overview of the model is included in figure B5. The charging poles can be controlled using on/off control or by controlling the output power over a range.

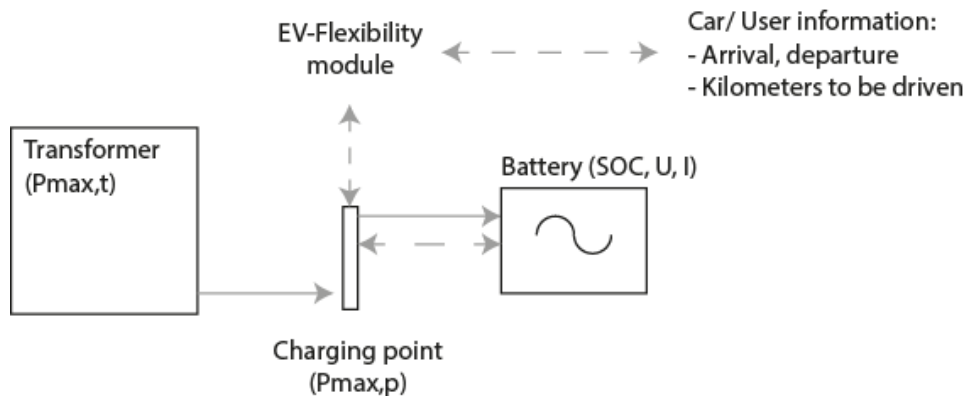

Figure B5: Schematic representation of EV charging.

Data sources

Information that is required to be able to forecast flexibility and control the charging of EV's is included in table B3. Data availability is the biggest challenge in smart charging since this involves either state-of-the-art data management and/or interaction with the user.

Table B3: Data sources for electric vehicle charging model.

	Data sources (sensors)	Building level sources (supporting or alternative)	Alternative in case no sensors present
Arrival time	Plugin detection at pole, agenda/reservation system (outlook, SAP), car GPS, phones etc.	Entrance barriers (counting)	Assumed profiles based on office hours and statistical models
Departure time	Provided by users, agenda/reservation system (outlook, SAP)	-	Assumed profiles based on office hours and statistical models
SOC at arrival	Measurements at the charger, communication with EV.		Provided by user
Required SOC at departure	Based on number of kilometre to be driven (user input)		Assuming SOC=1 is required.

Use scenarios

To analyse the potential flexibility statistical models for arrival and departure times and initial SOC are used. The two considered scenarios are 1) employees lease the cars and charge them at home and 2) cars are available for employees during the day. Normal distributions are used to determine arrival and departure times. The statistical models can be adjusted by the standard deviation and means of the normal distributions that are used to determine arrival and departure times. Examples for two scenarios are provided in figure B6. A random generator is used to provide the SOC of the battery at arrival reflecting differences in kilometres travelled, driving styles and car types.

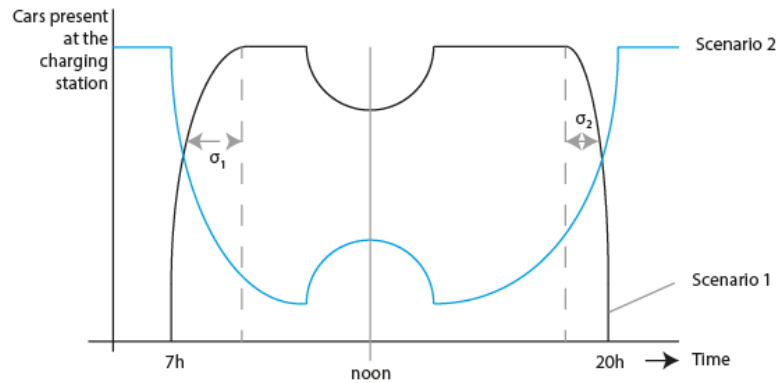

Figure B6: EV use scenarios

Sensible heat storage buffer

The heat pump performs optimally at constant power or rpm. The number of switching actions and power also influences heat pump lifetime. To ensure more stable operation, a buffer vessel may be used. Using a storage vessel as buffer also leads to optimal flexibility in the operation of the heat pumps, practically decoupling heat demand of the building and the heat pump so heat pumps can be used at optimal times.

Process model for sensible storage buffer

For the simulation of the storage vessel an energetic model is used in which the temperature of the storage medium is based on the stored energy. The charging and discharging of the storage buffer is similar to battery charging. Losses to the environment are taken into account (assuming cylindrical shape). There are various alternatives to integrate the buffer, an example is presented in figure B7.

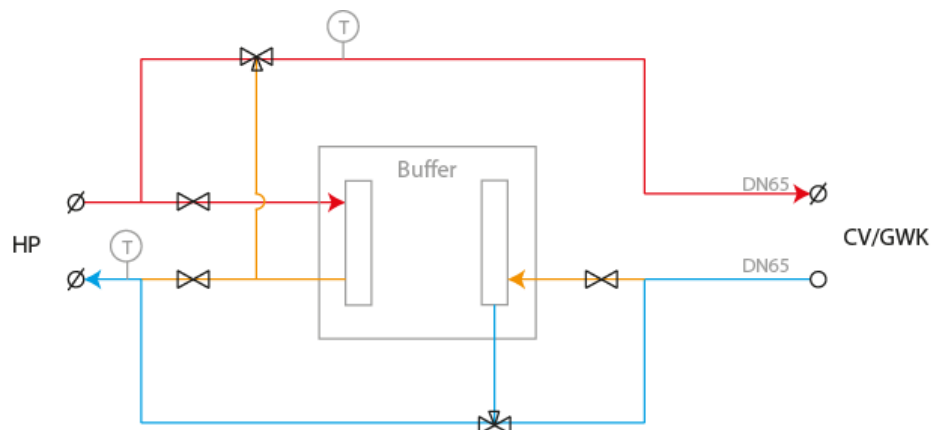

Figure B7: Schematic representation of the buffer integrated between the heat pump (HP) and the distribution system (CV/GWK).

Data sources

Required data sources are included in table B4.

Table B4: Data sources for sensible heat storage model.

	Data sources (sensors)	Building level sources (supporting or alternative)	Alternative in case no sensors present
Buffer status	Temperature sensors	Historical data	-
(future) heat demand	Prediction module, historic data, profiles.	Depending on ambient temperature	Not include losses, assume profile
Heat pump efficiency and production	Temperature sensors (in/out), electric consumption, switch mode/control mode, mass flows.	-	Profiles, general indicators
Distribution system status	Temperatures (in/out), mass flow	-	-

This page is intentionally left blank

3TU.School for Technological Design,
Stan Ackermans Institute offers two-year
postgraduate technological designer
programmes. This institute is a joint initiative
of the three technological universities of the
Netherlands: Delft University of Technology,
Eindhoven University of Technology and
University of Twente. For more information
please visit: www.3tu.nl/sai.