

Behaviour of bond lines in dww reinforced timber connections

Citation for published version (APA):

Brandon, D., & Leijten, A. J. M. (2014). Behaviour of bond lines in dww reinforced timber connections. In A. Salenikovitch (Ed.), *Proceedings of the World Conference on Timber Engineering (WCTE 2014), 10-14 August 2014, Quebec, Canada* (pp. 1-7). FPIInnovations.

Document status and date:

Published: 01/01/2014

Document Version:

Publisher's PDF, also known as Version of Record (includes final page, issue and volume numbers)

Please check the document version of this publication:

- A submitted manuscript is the version of the article upon submission and before peer-review. There can be important differences between the submitted version and the official published version of record. People interested in the research are advised to contact the author for the final version of the publication, or visit the DOI to the publisher's website.
- The final author version and the galley proof are versions of the publication after peer review.
- The final published version features the final layout of the paper including the volume, issue and page numbers.

[Link to publication](#)

General rights

Copyright and moral rights for the publications made accessible in the public portal are retained by the authors and/or other copyright owners and it is a condition of accessing publications that users recognise and abide by the legal requirements associated with these rights.

- Users may download and print one copy of any publication from the public portal for the purpose of private study or research.
- You may not further distribute the material or use it for any profit-making activity or commercial gain
- You may freely distribute the URL identifying the publication in the public portal.

If the publication is distributed under the terms of Article 25fa of the Dutch Copyright Act, indicated by the "Taverne" license above, please follow below link for the End User Agreement:

www.tue.nl/taverne

Take down policy

If you believe that this document breaches copyright please contact us at:

openaccess@tue.nl

providing details and we will investigate your claim.

BEHAVIOUR OF BOND LINES IN DVW REINFORCED TIMBER CONNECTIONS

Daniel Brandon¹, Adrian Leijten²

ABSTRACT: This paper presents a study of the behaviour of bond lines of Densified Veneer Wood (DVW) reinforced timber connections. Studies by Leijten in the 90s have shown that reinforcing timber connections with DVW results in a significant enhancement of connection properties. The DVW is in these connections glued onto the timber. Recently, these reinforced connections were studied in column-beam and splice type arrangements using a connecting flitch plate. In these arrangements additional stresses are introduced in the bond line. A numerical study was performed to the bond line capacity, but experiments did not fully verify the predictions. For the present study the fracture mechanical properties of bond lines between DVW and Norway Spruce were determined experimentally, and were implemented in three dimensional finite element models. Delamination tests were performed to verify the numerical procedure. From these tests it is concluded that the numerical predictions correspond well to the experiments.

KEYWORDS: densified veneer wood, reinforced connection, glued timber connection, bond line

1 INTRODUCTION

Reinforcing timber connections with densified veneer wood (DVW) plates results in a high connection strength and stiffness [1]. DVW is a cross laminated beech veneer that is compressed at high temperatures to a density of approximately 1300 kg/m³. The high embedment strength, embedment stiffness and tensile strength in every in-plane direction make this material suitable for reinforcing timber. Steel tubes are used as dowel-type fasteners. These easy fitting tubes are expanded with a hydraulic jack after positioning them in pre-drilled holes. After assembly no hole clearance is left, resulting in a high initial connection stiffness. The first study of DVW reinforced connections [1] was on 3-member connections (Figure 1a). The present study focuses on flitch plate connections in a splice type (Figure 1b, 1c) and column-beam (Figure 1d) arrangement. A flitch plate connection can be seen as two 3-member connections that are acting in series. Therefore, a flitch plate connection generally has only half the stiffness of a 3-member connection. However, if the timber and DVW members are closely spaced, they can come into contact and suppress each other's rotation (Figure 2).

The moment-rotation behaviour of the flitch plate connection was recently studied by the authors [2, 3]. This study showed that the stiffness of the flitch plate connection can be as high as the stiffness of a 3-member connection. It also showed that the flitch plate connection has a higher moment capacity than the 3-member connection. For predictions different failure mechanisms were considered. Due to a stiffness difference between timber and DVW, the rotation suppressing effect introduces additional stresses in the bond line, which may lead to failure.

In [3] numerical analyses of the bond line showed that the

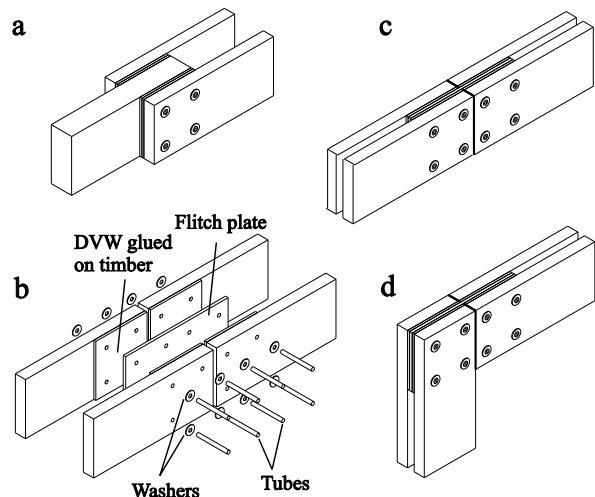

Figure 1: DVW reinforced connections

¹ Daniel Brandon, University of Bath, 6 EAST Claverton Campus, BA2 7AY, Bath, United Kingdom. email: d.brandon@bath.ac.uk

² Adrian Leijten, Technische Universiteit Eindhoven.

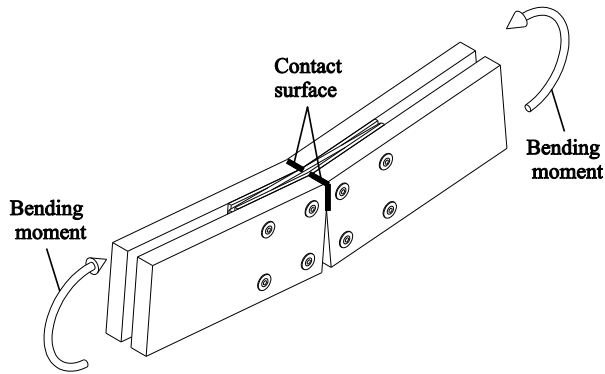

Figure 2: Rotation suppressing effect

bond line would not govern the connection strength and the experimental results of connection tests indeed did not show bond line failure. Since no comparison between the tested and predicted bond line capacity could be made, the experiments did not fully confirm the predictions of the bond line capacity.

In this paper a series of delamination tests are presented, in which bond line failure occurred. A numerical prediction of the bond line shear capacity was made following the same procedure as presented in [3] and was compared to the results of the delamination tests.

2 BACKGROUND

A number of methods predicting the behaviour of bond lines are known. A well-known analytical method is reported by Volkersen [4]. The theory of Volkersen clarifies, that there will be peak shear stresses in the bond line due to differences in strain of adherents as shown in Figure 3. The difference between the peak shear stress and the median shear stress will increase for increased bonded lengths. The theory assumes that plain cross sections of the adherent remain plain and do not rotate, which means that shear stresses in the adherents are not accounted for. Therefore, predictions for bonded connections with thick adherents are questionable [5]. Also local damaging or

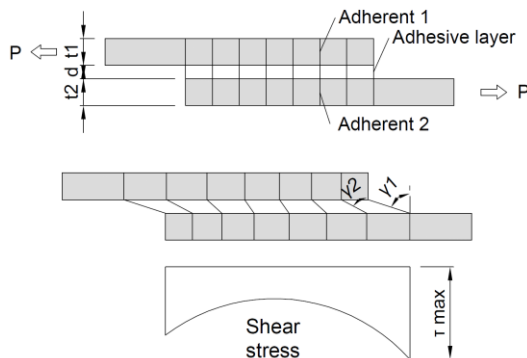

Figure 3: Shear stress distribution according to Volkersen [4]

softening of the bond line is not taken into account. Therefore the Volkersen method can significantly underestimate the bond line capacity of timber connections.

Non-linear finite element models can describe the softening of bond lines and the shear deformation in the timber adherents. For this, fracture mechanical properties of the bond line are required. These properties depend mainly on [6]:

- The type of adhesive
- Adherent material and its surface conditions
- Methods and conditions of gluing and curing
- Bond line thickness

Most research to the fracture mechanical properties of bond lines studies bonds with two timber adherents [5-10]. The connections studied in [1-3] contain bond lines with two different adherents: DVW and Norway Spruce. Reports of bond line tests with these adherents have not been found.

This paper presents small scale and larger scale tests of bond lines comprising of DVW and Norway Spruce adherents different adhesives and different bond line thicknesses. The small scale tests aimed to determine the fracture mechanical properties of the bond lines and the larger scale tests confirmed predictions made with these properties.

2.1 BOND LINE PROPERTY TESTS

For numerical predictions the bond line properties are required in three different directions. These are: shear properties in parallel to grain direction; shear properties in perpendicular to grain direction; and tensile properties normal to the glued surface. The setups of the shear and tension tests are shown in Figure 4 and 5, respectively. The shear tests specimens consisted of a DVW adherent and a Norway Spruce adherent of 15 by 20 mm with a 5 mm thickness. The average density of the DVW and Norway spruce were 1331 and 456 kg/m³, respectively, after being conditioned in 65% relative humidity and 20 °C for more than 6 months. The adherents were glued by a 5mm wide strip of adhesive with a thickness of 0.2 mm and 0.7 mm. Epoxy and polyurethane (PU) adhesives (see Table 1) were used with two bond line thicknesses. The tensile test specimens consisted of similar adherents with dimensions of 25 by 25 mm. Also these specimens were glued with a 5 mm wide strip.

Table 1: Tested adhesives

Adhesive type	Product
2-component Epoxy	WEVO spezialharz EP 32 S with WEVO-härter B 22 TS



Figure 4: Bond line shear test



Figure 5: Bond line tension test

The relationship between the adherents' relative displacements and bond line stresses was determined. From the resulting curves, the fracture energy, bond line stiffness and strength were determined. Average values were used for the finite element predictions.

3 FINITE ELEMENT MODELS

In [3] two finite element models were made to predict the bond line behaviour of the DVW reinforced connections. These 3 dimensional models were used to predict different failure mechanisms including bond line failure. In agreement with the numerical predictions, experiments did not show bond line failure. The experiments, therefore did not fully confirm the accuracy of the numerical procedure.

In this paper a similar finite element analysis is used to predict the bond line capacity of simple 3-member glued connections, in which the load is parallel to the grain (Figure 6). Only half of the connection is modelled using the symmetry plane as a boundary condition. This test can be sufficiently modelled with a 2-dimensional FE model. However, in order to resemble and validate the numerical method applied in [3] a 3-dimensional model is chosen.

Four different glue line lengths L are modelled: 50, 100, 150 or 200 mm. The thickness of the timber and DVW is 40 mm and 16 mm, respectively, and the depth of both is 100 mm. All models were made using ABAQUS version 6.10. The elements used for the DVW and timber members are 3-dimensional 8 node elements using reduced integration and enhanced hour glass control. The bond line behaviour is simulated using cohesive elements. These elements are also 3-dimensional, have 8 nodes and an upper and a lower face. These surfaces are tied to the

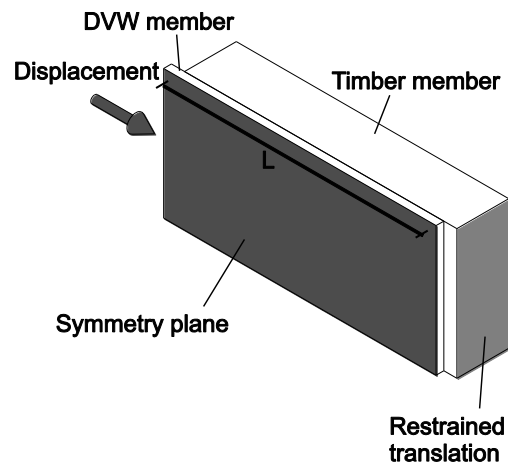

Figure 6: Finite element model geometry for experimental verification

adherents and are 5 by 5 mm. This way, the size of the cohesive elements resembles the size of the small scale bonds that are tested as described above.

The element size of the adherents is for computational purposes recommended to be twice the element size of the cohesive layer. Therefore, an element size of 10 mm in all directions is adopted for the DVW and the Timber. There is an exception: the mesh of the DVW plates has three elements in the thickness direction, to be able to model shear deformations in the plate.

Orthotropic material behaviour is chosen for Norway Spruce. The implemented Young's moduli are 10.7, 0.57 GPa for the parallel and perpendicular to grain directions respectively. The implemented shear modulus is 0.56 and the rolling shear modulus is 0.02 GPa.

The DVW plate is modelled as an isotropic material with a Young's modulus of 18.0 GPa and yield strength of 80 MPa and a Poisson's ratio of 0.3.

The (fracture) material properties of the bond line required for the cohesive elements are determined with the tests discussed above. The results of these tests and the implemented values in ABAQUS are given in the results section.

4 EXPERIMENTAL VALIDATION

To validate the prediction of the bond line shear capacity delamination tests were performed in parallel to grain direction. The adhesive used was Poly Urethane as discussed above. The setup of these tests is shown in Figure 7. A series of 8 tests was performed for each glue line length L . Where L was 50, 100, 150 or 200 mm. Half of the tests contained 0.2 mm thick glue lines and the other half contained 0.7 mm thick glue lines. The tests were displacement controlled with a speed of 0.3 mm/min

The timber used for the tests was glued laminated Norway Spruce with an average density of 427 kg/m³. The DVW had an average density of 1306 kg/m³. Small sheets of PTFE (< 1cm²) were placed in between the adherents before gluing to control the glue line thickness.

5 RESULTS AND DISCUSSION

The results of the bond line property shear tests (Figure 4) are shown in Figure 8-11. The experimental results are represented by the grey curves. An approximate curve (black) is generated with the average peak co-ordinate and the average enclosed area of the grey curves. These approximate curves are showed together in Figure 12.

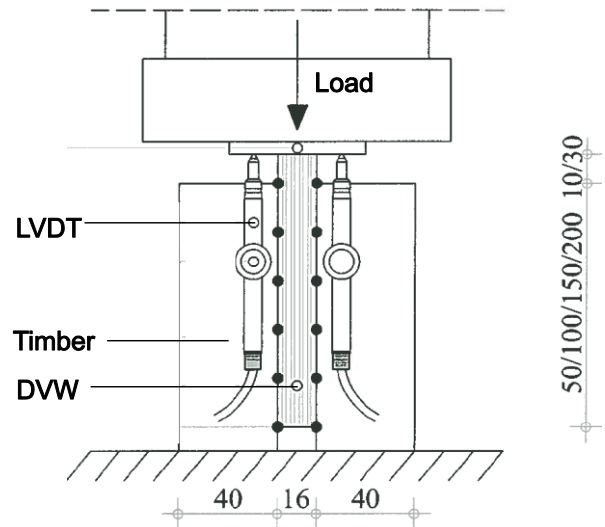

Figure 7: Setup of 3-member delamination tests

It can be seen that epoxy (EPX) bond lines have higher stiffness and strength than PU bond lines. A significant difference in fracture energy, which is equal to the enclosed area of each curve, was observed for the PU adhesives. The thicker glue line resulted in significantly higher fracture energy. Remarkably, this difference was not seen for EPX bond lines. This can be explained by the different failure mechanisms that occurred in the different bond lines. Failure of all of the PU samples occurred in the adhesive layer (Figure 14), while failure of the EPX samples occurred in either the timber (Figure 15) or the interaction between the timber and the adhesive. The last two are brittle failure modes, while adhesive failure can be ductile.

Figure 13 shows the results of the tensile bond line tests and is generated in the same manner as Figure 14. No significant difference is observed for different tested bond lines. This can be explained by the fact that all samples showed the same failure mode, which is timber splitting (Figure 16). It can therefore be concluded that both adhesives are stronger in tension than timber perpendicular to grain, and the timber governs the fractural behaviour of the bond line.

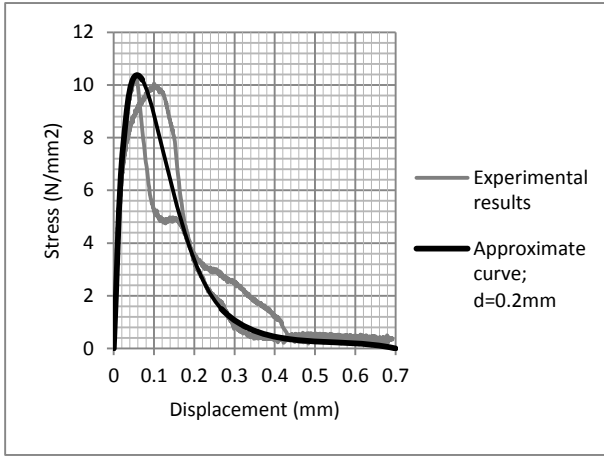

Figure 8: Results of bond line shear tests with a 0.2mm thick PU glue line

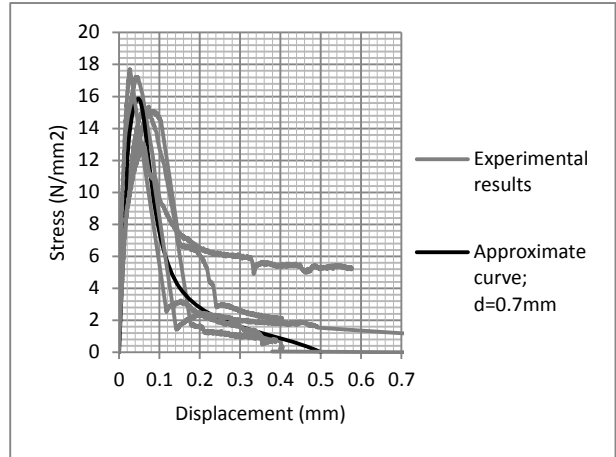

Figure 11: Results of bond line shear tests with a 0.7mm thick epoxy glue line

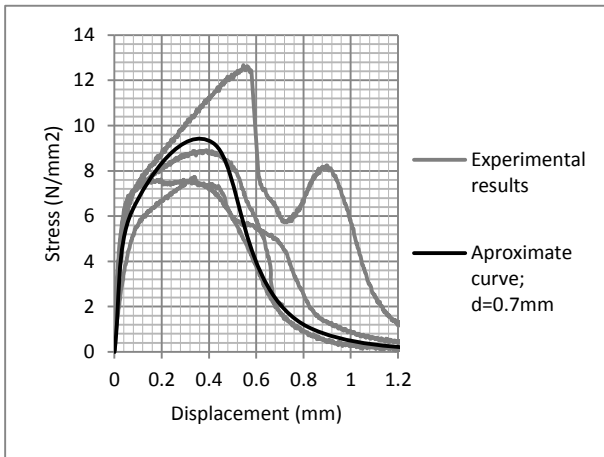

Figure 9: Results of bond line shear tests with a 0.7mm thick PU glue line

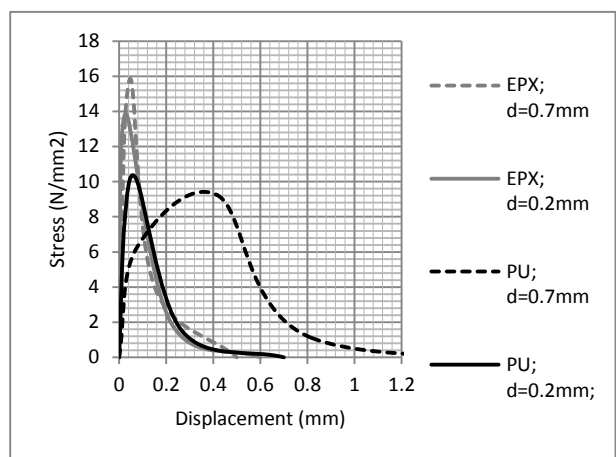

Figure 12: Results of bond line shear tests

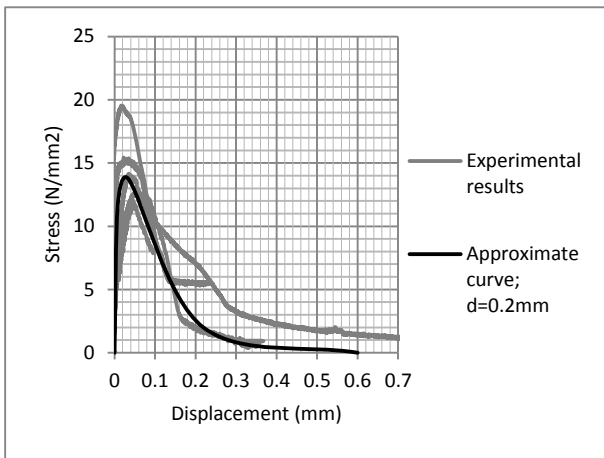

Figure 10: Results of bond line shear tests with a 0.2mm thick epoxy glue line

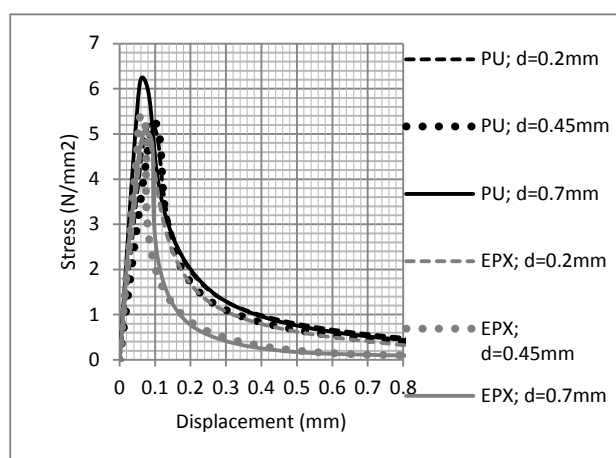

Figure 13: Results of bond line tensile tests



Figure 14: Typical PU shear test specimen after testing



Figure 15: Typical EPX shear test specimen after testing



Figure 16: Typical tensile test specimen after testing

5.1 MATERIAL PARAMETERS

The cohesive elements that are used in ABAQUS simulate a bi-linear relationship between stress and relative displacement of the adherents. The small scale bond line test results of the tests described above needed to be simplified in order to be applied in ABAQUS. For this, a bi-linear curve is generated with the same maximum stress and fracture energy as the curves that resulted from the experiments (Figure 17). The input parameters that correspond to these curves are given in Table 2, 3 and 4. In which G is the fracture energy, t is the strength, and K is the stiffness of the bond line. The subscripts 1, 2 and 3 correspond to: the parallel to grain; in-plane perpendicular to grain; and out of plane perpendicular to grain directions, respectively.

Table 2: Fracture energy parameters for PU adhesive

Glue line thickness	G_1 (J/m ²)	G_2 (J/m ²)	G_3 (J/m ²)
0.2	1300	1580	2.73
0.7	1300	4540	9.56

Table 3: Strength parameters for PU adhesive

Glue line thickness (mm)	t_1 (N/mm ²)	t_2 (N/mm ²)	t_3 (N/mm ²)
0.2	5.6	10.34	1.78
0.7	5.6	7.95	1.78

Table 4: Stiffness parameters for PU adhesive

Glue line thickness (mm)	K_1 (N/mm ³)	K_2 (N/mm ³)	K_3 (N/mm ³)
0.2	400	345	696
0.7	275	69	199

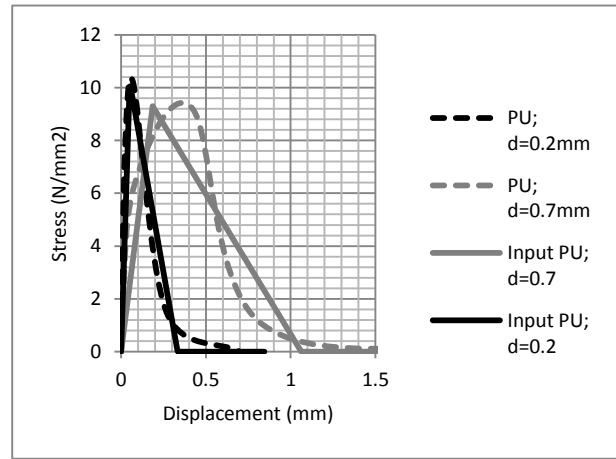

Figure 17: Simplified bi-linear curve and experimental results for parallel to grain shear

5.2 DELAMINATION TESTS

In the delamination tests the governing failure mode was bond line failure. However, in some specimens parts of the timber surface sheared off. Average results of the delamination tests are shown in Table 5 and are compared with results of the finite element analysis. The FE analysis on average underestimates the bond line capacity by 8.5%. The average difference between the FE predictions and the experimental results is 16% and is larger for predictions of bond lines with a 0.2 mm thickness.

Figure 18 shows the experimental and FE results. This figure shows that the finite element predictions for shorter glue line lengths are more accurate than for longer glue line lengths. For glue line lengths over 100 mm the finite element analysis is under predicting the bond line capacity and is especially apparent for the small glue line thickness of 0.2 mm.

This suggests that the use of the finite element procedure for long glue lines, leads to conservative results. This, therefore, indicates that the numerical results presented in

[3], using the same finite element procedure as described above and glue line lengths over 300mm, are conservative.

Table 5: FE and average experimental results

Glue line thickness (mm)		L=50 mm	L=100 mm	L=150 mm	L=200 mm
0.2	FEM (kN)	76.5	124.9	132.8	133.5
	Exp. (kN)	55.9	128.1	174.8	166.0
	Diff. (%)	26.9	2.5	31.6	24.4
0.7	FEM (kN)	60.5	123.2	152.1	157.4
	Exp. (kN)	75.7	119.3	153.6	178.8
	Diff. (%)	25.1	3.2	1.0	13.6

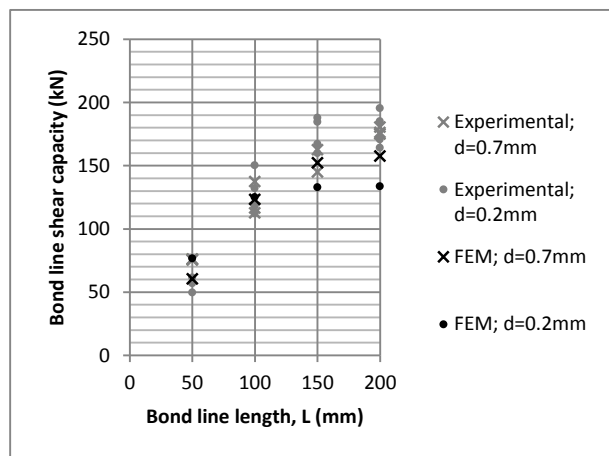

Figure 18: Results of delamination tests and finite element analysis

6 CONCLUSIONS

For this study bond line delamination tests are performed and compared with finite element predictions. The finite element analyses are performed using ABAQUS version 6.10, in which cohesive elements are used to describe the behaviour of the bond line. The material parameters for these elements are determined with small scale bond line shear and tensile tests.

From the delamination tests and the finite element analyses the following is concluded:

- For the shear tests parallel to grain, the failure occurred in the adhesive if a poly urethane adhesive was used;
- the results show that there is a non-linear relationship between bond line capacity and glue line length;

- the finite element analysis gave conservative predictions for the shear capacity of bond lines longer than 100 mm;
- the finite element analysis corresponds well to the experimental results for bond lines of 100 mm;
- the finite element prediction for bond lines with a glue line thickness of 0.7 mm is more accurate than the prediction for 0.2 mm glue line thickness.

ACKNOWLEDGEMENTS

The authors acknowledge Professor Per Johan Gustafsson for hosting the first author at Lund University for a part of the experimental study.

REFERENCES

- [1] Leijten A.J.M.: Densified veneer wood reinforced timber joints with expanded tube fasteners. PhD Thesis, Technische Universiteit Delft, 1998.
- [2] Leijten A.J.M. and Brandon D.: Advances in moment transferring DVW reinforced timber connections- Analysis and experimental verification, Part 1. *Construction and Building Materials*, 43:614-622, 2013.
- [3] Brandon D. and Leijten A.J.M.: Advances in moment transferring DVW reinforced timber connections- Numerical analysis and verification, Part 2. *Construction and Building Materials*, 56:32-43, 2014.
- [4] Volkersen O. Die Niekraftverteilung in Zugbeanspruchten mit Konstanten Laschenquerschnitten. *Luftfahrtforschung* 1938; 15.
- [5] Gustafsson P.J.: Tests and test results on mechanical properties of adhesive bond lines. In: Johansson C.J., Pizzi T., Van Leemput M. COST action E13 – wood adhesion and glued products. 7-24. 2002
- [6] Gustafsson P.J.: Adhesive Joints. In: Johansson CJ, Pizzi T., Van Leemput M., editors. Cost Action E13 – Wood Adhesion and Glued Products, COST; 2002, p. 79-122.
- [7] Serrano E.: Adhesive joints in timber engineering – modeling and testing of fracture properties, PhD-thesis, Lund Univ. Sweden. 2000.
- [8] Gustafsson P.J., Serrano E.: Glued truss joints analysed by fracture mechanics, In: 5th World Conf. Timber Eng. Montreux, Switzerland, 1998.
- [9] Sterley M., Serrano E., Enquist B.: Fracture characterisation of green-glued polyurethane adhesive bonds in Mode I. *Materials and Structures* 2013; 46:3. p. 421-434.
- [10] Serrano E., Gustafsson P.J., Larsen H.: Modeling of Finger-Joint Failure in Glued-Laminated Timber Beams. *Journal of Structural Engineering* 2001; 127:8. p. 914-921.