

CIB2007-137

# Technology and Knowledge Transfer for Capability Building in the Ghanaian Construction Industry

Emilia van Egmond &amp; Peter Erkelens

## ABSTRACT

This paper presents the findings of a needs assessment (NA) which served to determine the particular needs for Institution (IB) and Capability Building (CB) in the Construction Industry (CI) for the upgrading of Building Technology (BT) education at two selected Polytechnics (PTs) in Ghana. The NA is part of a project, carried out to contribute to the improvement of the CI by means of Technology and Knowledge Transfers (TKTs) for IB and CB at PTs in Ghana. The methodological approach is multidisciplinary. The paper discusses the Ghanaian CI; the Ghanaian education system, particularly education in BT; the state of art of education programs, staff capabilities, teaching materials and facilities for the BTech and MTech curricula in BT. It concludes with recommendations for strategies for TKTs, IB and CB, and the organisation and teaching in the Ghanaian context.

**KEYWORDS: Technology and Knowledge Transfer, Capability Building, Construction Industry, Developing Countries, Ghana**

## 1. INTRODUCTION

Globalisation, innovations and technology and knowledge transfers (TKTs) have significantly changed the dynamics in the world economy.

Globalisation - for many local construction enterprises in developing countries - has unfortunately become tantamount to a sustained acquisition of technologies from abroad, while making little use of the existing domestic technology stock. Literature points at a lack of capabilities -an extensive T&K base- in a strong innovation system as important factors for this situation for many construction industries (CI) in developing countries (DC)s. (Egmond, E. van ;Kumaraswamy, M. & Ofori,

G (2003) Knowledge is acknowledged to be a key to socio-economic development.

The project "Capacity building in the Sunyani and Cape Coast Polytechnics to Improve Performance of the Building and Construction Industry in Ghana" aims at Institutional development, Capability Building (CB) and Strengthening of the network of the PTs in Sunyani and Cape Coast with other organizations and individuals in the innovation system of the CI in Ghana by using TKTs. The country is harmed by a fast growing population, a high rate of urbanisation and a shortage of qualitatively adequate housing and infrastructural facilities. It is expected that the results of the project positively influence the production performance of the CI, its contribution to overall socio-economic development, the competitiveness of the enterprises in the CI in Ghana and strengthen them to survive in the global knowledge based economy. The Needs Assessment (NA) is part of this project. The NA is carried out to determine the particular technology and knowledge (T&K) gaps which need to be replenished by means of TKTs to be able to bring about IB and CB in order that the PTs will be able to offer Building Technology (BT) education that is qualitatively up to international standards. The NA should provide data for the determination of the terms of reference for the development of the curricula for the Departments of BT of the Sunyani and Cape Coast PTs.

This paper includes the following sections (1) introduction, (2) methodological approach which is multidisciplinary; it integrates building engineering, socio-economics and management studies, (3) the Ghanaian CI, (4) the Ghanaian education system, particularly education in BT, (5) the state of art of education programs, staff capabilities, teaching materials and facilities for the BTech and MTech curricula in BT, (6) Conclusions regarding strategies for TKTs, IB and CB, especially organisation and teaching in the Ghanaian context.

## **2. METHODOLOGICAL APPROACH**

The NA took place in 2005 by the authors of this paper. A multi-disciplinary approach in which socio-economics, engineering and educational studies were combined, was used in this NA. The NA included a number of sub-studies on (1) the Ghanaian construction industry, (2) the Ghanaian education system particularly BT education and (3) the state of art of the education at the two PTs in Cape Coast and Sunyani.

Data collection took place by means of (a) literature studies, (b) structured and un-structured interviews with the Principals of the PTs in Cape Coast and Sunyani, the Head of the Schools and the staff for the envisaged education programs on Building Technology; as well as with the staff of the KNUST at Kumasi and professionals working in the CI in Ghana, (c) Personal observation of the available teaching, library and ICT facilities, (d) a quick scan of the application of building systems and

equipment in a sample of building projects both in rural and in urban areas by means of site visits and personal observations.

The data that were collected are both qualitative and quantitative data. The main issues of the interviews and questionnaires included the management system and organizational set-up of the PTs; the management vision regarding IB and CB for BSc and MSc curriculum development in BT; the time planning for curriculum development and staff training. Data collection included also the data on the present BT education at the Cape Coast and Sunyani PTs, the teaching methodologies – theoretical learning, training of practical skills and competencies, industrial attachments – and needs for improvement; the state of art of teaching capabilities and educational background of the PT staff, staff preferences for involvement in particular teaching subjects and needs for staff training in order to enable them to successfully implement the envisaged curricula; the state of art of teaching materials – handbooks, lecture notes - and needs for acquisition and/or revision; the state of art of teaching and learning facilities (laboratories, workshops, furniture, equipment, tools) and ICT facilities (computer hardware and software) and needs for improvement and acquisition. Several documents were investigated on the international accreditation standards.

The assessment study among the staff at the PTs –all available teachers at Cape Coast (5 persons) and at Sunyani (16 persons) were interviewed.- resulted in an identification of the specific needs for training and monitoring and made clear what the most efficient way will be to address these needs.

Based on these data conclusions could be drawn on the particular needs for revision of the curricula for the Building Technology education programs at Cape Coast and Sunyani PTs relevant and in accordance to international standards; IB and CB in terms of teaching and learning facilities (study books and lecture notes, laboratories, workshops, furniture, equipment, tools) and ICT facilities (computer hardware and software) and staff development up to BSc, MSc and PhD level.

The findings were cross checked with Principals and Head of Schools of the PTs, staff of the KNUST at Kumasi and professionals working in the CI in Ghana.

### **3. GHANA AND THE CONSTRUCTION INDUSTRY**

The population in Ghana - has doubled in a period of 20 years time to little over 20 million people and is expected to grow annually at 2.1% for the period 2000-2015. (CIA 2003). Ghana has a large pool of inexpensive, unskilled labor. The educational attainment is relatively low. Of the economically active population (15 years and older) 2.3% is employed in the CI. (GSS 2000) Although the housing needs –due to population growth and urbanization- is more of qualitative than quantitative nature, the infrastructural and housing needs put pressure on the output of the

domestic CI which apparently has no sufficient capacity and capabilities to fulfill the needs. (Egmond, E van & Vulink, M 2005)

The CI in Ghana is characterised by a multiplicity of small firms. An important part (>75%-90%) of the construction activities take place in the so-called informal construction system in Ghana. The exact percentages are hard to assess. In 2002 the total number was 7095 formally registered construction firms, 90% of which are small contractors (no complex construction jobs, tender sum up to one million dollars) who belong to classes D3 and D4. Tawiah (1999) notes that the total amount of work executed by them ranges between 10% and 20% of the (formally registered) total construction output. He also mentioned that proprietors who have little or no knowledge in the CI head the Ghanaian owned firms. In their perception of construction is a business, the only requirement is financial ability. The management of the firms' resources – labour, finances, materials and plant and equipment is carried out haphazardly and therefore does not promote an improved performance and growth of the firms. This becomes evident by the fact that the nation's major construction projects are awarded to the very few large mostly foreign contractors (Tawiah 1999; originally Ofori 1991). Moreover the majority of Ghanaian contractors do not have sufficient access to funds, credit facilities and do not have the appropriate technological capabilities, plant and equipment and key personnel to handle projects properly. They cannot compete with foreign contractors, especially when it concerns more complex projects. With these attributes the foreign firms have a competitive edge over the Ghanaians. It is increasingly evident that the foreign firms are more able to capture a major share of the local construction market than their local counterparts.

About ten international construction companies are working in Ghana. Most basic building materials are at present produced in Ghana and sufficiently available (Interbeton 2005).

The development of new technologies - designs, materials and components have become more complex- the growing sophistication of customers and increasing competition between product and service suppliers have brought about profound changes in business practices in the CI. Firms are urged to develop the expected capacities to meet the requirements in the industry. These emerging trends pose a great challenge to Ghanaian contractors.

#### **4. BUILDING TECHNOLOGY EDUCATION IN GHANA**

Capability building (CB) relates to the process of gaining knowledge and skills, which can take place in various ways, among which by formal training and education programs. The National Council for Tertiary Education (NCTE) and the Non-Formal Education Division (NFED) have an important responsibility regarding the provision of education in Ghana.

Formal Technical/Vocational Education is provided in Secondary/Technical Schools, Technical Institutes, Vocational Schools

/Training Centres and other post-basic education training institutions. This also applies for training and skills development in BT at secondary level: Construction Technology Courses (CTC). Basically, the purpose of technical and vocational education is to equip young men and women with the technical and professional skills needed for the rapid socio-economic development of the country. The emphasis is on training people for self-employment. Technical and vocational education has been given a boost by the government. At the moment Ghana can boast of 23 public technical institutes and several private ones including Vocational Institutions. In 1991 the Government launched the White Paper on Tertiary Education. The major objective was to expand access, improve quality teaching and learning and provide the much-needed infrastructural base for accelerated technical manpower delivery for sustainable economic development. The Ministry of Education Youth and Sports (MOEYS) is determined to assist the PTs to develop highly skilled middle-level manpower. To this end PTs are encouraged to introduce Post HND and Bachelor of Technology programmes. The Sunyani and Cape Coast PTs therefor have taken steps to establish first and second degree curricula in technology namely, Bachelor of Technology (B-Tech) and Master of Technology (M-Tech).

However the enrolment in vocational training institutes for training in the construction trades is negligible (JICA 2003). The Ghanaian CI is dominated by many people who are not able to read and translate architectural drawings into reality. Training and education of personnel for the CI in Ghana –at least at vocational level- takes in majority place on informal basis by apprenticeship whereby young people –mostly men- learn the trade from more experienced masons, carpenters, etc. Informal training has limitations: (1) a restricted learning opportunity (learning by doing), (2) a narrow and static range of skills; (3) the difficulty of instruction in new technologies and techniques. In many African countries the informal apprenticeship system is not well developed and the master craftsmen who do the training may themselves have very limited skills. (ILO 2001, Wells 2001). The informal method of technological knowledge acquisition and skill formation then does not any longer comply with the actual demand for construction output. The “learning-by-doing” system in this way is not “costless”, but rather costly and time consuming with little pay back. Bell et al (1984) argue this point further and suggest that firms cannot rely on “learning-by-doing” in order to develop their technological capabilities; they must invest in training and other knowledge creation. The acquisition and understanding of knowledge requires a deliberate allocation of resources.

Seven of the 10 PTs in Ghana provide training in BT at Higher National Diploma (HND) level. They are expected to fill the void by training mid-level personnel capable of supervising the artisans so as to produce high quality buildings. These PTs however are confronted by the perennial problem of inadequate funding and poor working conditions in the tertiary education sector in Ghana. The 7 PTs that offer BT produce about 350 graduates per year instead of the industry required 700. Furthermore, a majority of these graduates cannot join the CI because they lack practical skills and competencies. In discussions with professionals during the NA in

Ghana was put forward that workers in the CI lack of taking initiative, have limited skills in problem solving, lack quality conscience and are not critical.

The wish was expressed to include more practical exercises and practical experience in the education.

The absence of practical training has led to a dearth of site technicians, quantity surveyors, qualified foremen, and middle level management for supervisory roles in the industry. Moreover a graduate from the PT with HND, who wishes to continue to obtain a degree (BSc) in BT at university level in Ghana is faced with the dilemma, either to begin in the first year with students who start with a secondary school diplom or forget it. This situation creates an additional need for the PTs to design and (re-)structure curricula, which address this problem. A revision of the curricula will not only contribute to improving the performance of the CI in Ghana, but at the same time it will also contribute to solving a serious problem in the field of academic qualifications.

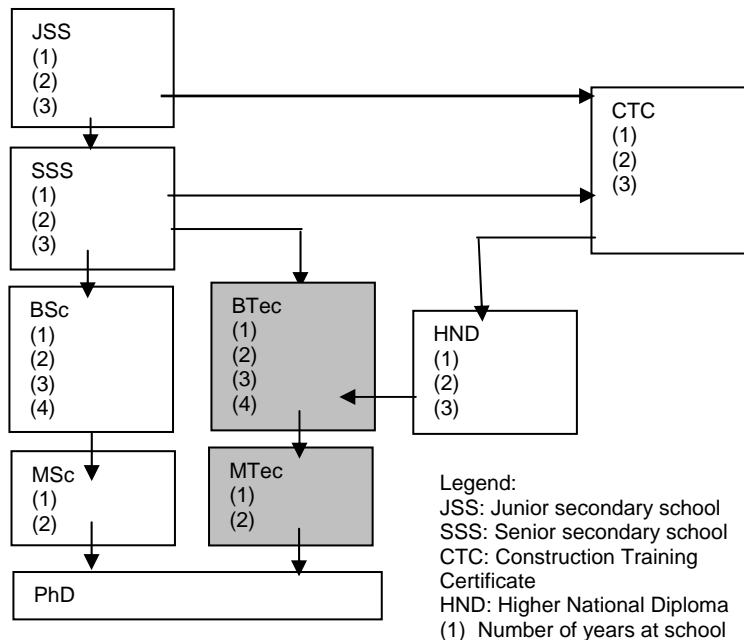

**Figure 1** Proposed educational structure

The heads of the departments of BT of the PTs in Cape Coast and Sunyani prepared a first set up of a revised curriculum including topics for both Btech and Mtech programs. These were based on BSc and MSc curricula and combined with elements of the already existing HND curriculum. The main distinction between the BSc/MSc and Btech/Mtech programs is that the Btech and Mtech programs have a more practical focus whilst BSc and MSc programs follow basically a scientific and theoretical approach. The aim of such a B-Tech curriculum in BT is to propel the graduate for a career as a professional construction manager,

concerned with planning, organizing and supervising the construction of buildings. The BTech curriculum will have to contain the basic technical topics to supply the graduate with the necessary basic engineering knowledge and skills as well as topics regarding the management of construction. BTech students also will be allowed to go for one year industrial training after the third year before completing the final year. The MTech curriculum will put particular emphasis on managerial aspects. In addition it is proposed to include in the MTech curriculum a new topic: Innovation management, which will cover issues like product development, building technology design, flexibility and durability, industrialization and prefabrication, maintenance, upgrading and renovation and innovative building technologies for the tropics. It will highlight the opportunities for the Ghanaian CI to adequately make use of the relevant state of art innovative technologies and knowledge. A primary condition for the envisaged curricula is that they have to meet first and for all the requirements of the Ghanaian Accreditation Board.

The Japan International Cooperation Agency (JICA 2003) advocated the adoption of a Competency-Based Training (CBT) approach in the Technical, Vocational Education and Training sector of Ghana. It is considered as an appropriate solution to the diverse education and training needs for post-secondary and adult learners, particularly in technical and skill-oriented programs. This teaching methodology involves a systematic learning process, in which the primary focus is on the students' ability to demonstrate competencies required in the industry. The competencies comprise appropriate knowledge and skills required to perform workplace roles. The methodology is expected to provide learners with recognition and accreditation of previously acquired knowledge and skills, flexibility in scheduling learning activity, self-paced individualized study determined by the student's learning style, a learning continuum determined by student needs, and the possibility of starting and finishing a program at any time during the year. Within this methodology attachments to industry are a vital components. The elaboration of the methodology in education programs is based on the identification of job competencies relevant to the needs of industries.

## **5. STATE OF ART OF BUILDING TECHNOLOGY EDUCATION AT THE CAPE COAST AND SUNAYANI PTS**

The staff of the PTs was requested to fill questionnaires and indicate -apart from personal data on their background etc.- which topics and in which way they are teaching at present at HND level and which Btech topics they like to teach in future. Those teachers who are expected to be qualified after graduation at university level during the collaboration project were asked to indicate which of the MTech topics they would like to teach in future. A distinction was made between those who will qualify in future for HND teaching, Btech teaching and those who will qualify for Mtech teaching after the attainment of a certain education level during the project.

The results of the questionnaires among the PT staff show that theoretically most of the topics could be taught by the available staff. Some topics will be taught by teachers from other departments due to the typical specialism (e.g. law etc.). It should be noted however that especially in the case of the Cape Coast PT the present teaching capacity is not sufficient. Only a limited number of teachers are at present employed in Cape Coast. Both PT's have indicated that they will attract new staff with a Bsc or Msc degree in near future, in order that the staffing problem is likely solved both in quality and quantity after the project period.



**Fig 2** Interviewing Sunyani PT staff

The present level of education and expertise of the staff of both PTs is found to be below the level of requirements for adequate teaching at BTech and Mtech level. Interviews during the needs assessment showed that a number of the staff of both PTs hold a HND degree or lower, some have a BSc and only a few of them a MSc. Degree. The findings of the NA indicate a rather large gap between the present culture of teaching and learning as well as the capacities of the staff at the PTs and those required for application of the methodology advocated by JICA.

At present teaching takes place mainly in the form of head-on lecturing by the teachers. The PTs show an inability at present to combine theoretical training with practical exposure in order to produce qualified graduates for direct absorption into industry.

Teaching materials presently consist mainly out of handouts made by the teachers. A limited number of books is available in the reference library and information is drawn from internet and accessible via the few available computers.

The specific needs for investments in laboratories, workshops, Information and Communication Technology facilities, educational materials and other equipment were identified in close collaboration with the PT staff. Both PT's have already some facilities for teaching like class rooms, workshops, laboratories, computer room and a library. However for the future it is foreseen that for each PT a more spacious workshop, a larger laboratory and a larger computer room is needed in order to house



equipment, computers and students. A list of indispensable laboratory equipment for testing and analysing properties and strength of building materials has been prepared. The access for both staff and students to ICT facilities like the Internet is almost a necessity. For the Departments of Building Technology at both the PTs it is needed that the already existing internet connections will be extended.

## 6. CONCLUSIONS

Based on the outcome of the NA the following activities were recommended for inclusion in the collaboration project Capacity Building in the Sunyani and Cape Coast Polytechnics to Improve Performance of the Building and Construction Industry in Ghana.

The teaching staff of the BT departments at both PTs need improvement of their capacity and qualifications to handle theoretical and practical issues related to BT and construction in general.

Two PhD candidates of the PTs in Cape Coast and Sunyani should carry out a PhD research project. This has to take place in a sandwich program, which means that they will work partly in the Netherlands and partly in Ghana with a joint supervision by the University of Technology at Eindhoven (TU/e) and the Kwame Nkrumah University of Science and Technology (KNUST). The field research has to be carried out in Ghana, during which periods the PhD candidates will be supervised by both the Dutch as well as the Ghanaian supervisors.

The PT teaching staff needs to be trained up to BSc and MSc level. In consultation with the KNUST it was decided that this training can take place at KNUST at Kumasi in tailor made (summer) courses, in order that the current teaching duties at the PTs will not become in dispute. To become acquainted with recent developments and technological innovations in the CI the project should include visits to the TU/e in the Netherlands by the PT teaching staff of the BT departments to observe and learn about modern trends in the industry.

Next to the general attainment of a BSc, MSc or PhD degree, the PT staff has to be trained to upgrade their didactical skills and prepare for a proper curriculum development and implementation of the new curricula in line with innovative didactical methodologies. An opportunity for this specific training will turn up during the period when the staff is visiting the TU/e at Eindhoven. The staff can then be trained at Eindhoven by professionals of the Education Service Centre of the TU/e.

The need for revising the current curricula is fully understandable. The current HND curriculum contains mainly a traditional set of courses like mathematics, mechanics, building physics, building construction, etc. It is recommended to take the following requirements for the envisaged Btech and Mtech curriculum in BT into consideration.

- The curriculum must contribute to capacity and capability building in the CI, in order to achieve an improved performance of the CI in Ghana.

- The factors of the local, tropical and social-economic situation in Ghana should not be neglected in the renewal, revision and development of the curriculum. This refers for example to the teaching materials which must be specific for an effective and efficient use in the Ghanaian setting.
- The curriculum has to contain aspects in order to contribute to achieving improvements in the social-economic, gender and environmental situation in the country. This can be translated in terms of employment, income, housing, education, health care in particular for the low income groups in the Ghanaian society. (Amankrah, J.Y. 2003)

It is further recommended that the CBT method should be considered in an adapted and appropriate form for application at the PTs. It should be applied as an instrument to achieve linkages between the educational institutions and the CI, business and community. Such an adaptation implies that Btech and Mtech teaching should include components of problem-oriented-teaching (POT). This means that apart from basic information provided by lecturing, the students will be trained in solving of practical problems that are indicated by the CI. This can be done through project work and by working in groups whereby the students have to find solutions for the practical problems by applying the theoretical knowledge and skills acquired during the lectures. The Education Support Services group at the Eindhoven University of Technology (TU/e) has been approached to assist in special training of the Ghanaian staff and development of an appropriate POT methodology.

Next to improving the curriculum and to solve the academic problem already mentioned before there is a good possibility to distinguish from the “standard” PT education in building technology. These goals can be achieved by introducing knowledge transfer in fields like advanced innovative building materials, building technology, construction technology, construction management, entrepreneurship and related skills.

With regard to the improvement of educational material for the envisaged BT curricula reference is made to extensive up-to-date lists of study books readily available for the traditional courses in BT like the City & Guilds’ package for BT education in the UK. Many PTs, in particular in former UK colonies are certified and take their exams in accordance with the City & Guilds guidelines. However the PT staff has to develop additionally new teaching materia. Some of those materials can be drawn from the thesis resulting of the individual Bsc/Msc studies at KNUST.

The reference library needs to be improved, which can be achieved by acquisition of more books in the field of the new curricula topics. A basic library, including the subscription to one or two journals or periodicals in the field of Building Technology, is more than relevant. Internet will play an important role for information in the future education. Those materials which are not prepared during the summer courses at KNUST can be developed by PT staff over the years.

Investments in teaching and learning facilities, tools and other equipment are required for the related disciplines at both PTs. Training equipment needs to be purchased and the laboratories, workshops and other teaching and learning facilities (including information and communication technology) need to be established. Investments in the facilities like a workshop, a larger laboratory and a larger computer room have been done by the end of 2005. Around 70 computers are made available by TU/e to the PT's.

In order to achieve the project objectives also the following aspects are addressed to fill the T&K gaps as determined by the NA: the implementation of (1) policies and procedures to stimulate staff to start long-term studies; (2) temporary replacement of staff engaged in long-term training; (3) a retention policy for staff with upgraded qualifications; (4) strategies to disseminate newly obtained knowledge and skills for example by using the BSc and MSc thesis material (or parts of it) prepared by the staff trained at KNUST as teaching material in the BTech and Mtech programs of the PTs.

To ensure the sustainability of IB and CB at the PTs it is recommended to make each of the PT staff responsible for the development of one or more courses offered in the new education programs. This implies that the Ghanaian teaching staff has to prepare and elaborate the envisaged Btech and Mtech programs. They also are expected to select, gather and prepare the necessary teaching materials such as study books, studyguidelines, hand outs, sheets, etc. Thus all staff of the two PTs needs to be involved in the review of the existing curriculum and the development and implementation of a renewed BT curriculum.

The Dutch TU/e staff have to assist in reviewing and modifying the current curriculum, support the development of new teaching methodologies and the implementation of the revised curriculum as well as the writing of the course books. The latter also needs to be done in consultation with the Ghanaian KNUST staff who train the PT teachers for their BSc and MSc degree. The Ghanaian PT staff member can be twinned with a TU/e expert as well as with experts of the KNUST for the development of the teaching program and material for a certain topic of the envisaged BSc. Next to the above TU/e staff is expected to give short introductory courses on a number of relevant BT topics when they are in Ghana during a mission. TU/e also have to assist in developing linkages with relevant industrial sectors and business fields in order to realise student attachment and staff exposure programmes. The arrangements for student attachments and staff exposure programmes can take place by using TU/e network with the CI.

The above mentioned recommended actions and policies involve transfer and exchange of T&K between the project partners of the international collaboration project "Capacity building in the Sunyani and Cape Coast Polytechnics to improve performance of the building and construction industry in Ghana". These TKTs -in the form of "training of the trainers", by which the Ghanaian PT staff gains the capabilities to develop and run the envisaged Btech and Mtech curricula in BT- are expected to

contribute to IB and CB at the PTs in Cape Coast and Sunyani. The sustainability of this TKT is enforced by the PhD research which contributes to the development of the Ghanaian R&D capacity for further independent development of higher education as well as for improvements in the CI in Ghana.

Through the PhD research carried out by two PT staff members with a joint supervision by TU/e and KNUST T&K is exchanged and transferred between the project partners. These TKTs contribute to an improved understanding and insight in The Netherlands and in Ghana on the nature and mechanisms of innovation of building products and building processes. The TKTs are thus beneficial for each of the project partners.

## 7. REFERENCES

- Amankrah, J.Y. 2003, *The role and potentials of skills development in poverty reduction, entrepreneurship and self-employment opportunities in Ghana: the case of MMDE's skills and employment strategy for poverty reduction*. ILO/ Ministry of Manpower, Development & Employment, 2003
- Bell, M., 1984 Learning and the Accumulation of Industrial Technological Capacity in Developing Countries
- CIA factbook. 2003. Internet: <http://www.odci.gov/cia> (updated 19-03-2003).
- Egmond, E. Van, Kumaraswamy, M., Ofori, G., 2003 Construction Industry Development through ITT in the global knowledge based economy: a research agenda; In *Proceedings of A Joint International Symposium of CIB Working Commissions, W55: Building Economics; W65: Organisation and Management of Construction; W107: Construction in Developing Countries. "Knowledge Construction"* Singapore 22-24 october 2003
- Egmond, E van & Vulink, M., 2005 International technology and knowledge flows in the African Construction Industry, In *Proceedings of the Africa seminar TVO 24-02-05*, Eindhoven The Netherlands
- Erkelens P.A., 2003 Cooperation with UNSAAC, Peru. In: *Proceedings of Technology for Development Symposium TU/e*, Eindhoven.
- Ghana Statistical Service (GSS). 2002. *2000 Population & Housing census*; summary report of final results, Accra Ghana.
- ILO 2001 *Tripartite Meeting on the Construction Industry in the Twenty-first Century: Its Image, Employment Prospects and Skill Requirements* Geneva, 2001
- Pacific Consultants International, 2001, *The study for the development of a masterplan to strengthen Technical Education in the Republic of Ghana*. JICA:/ Ministry of Education /The Republic of Ghana. Final Report.
- Ofori, G., 1994 Construction industry development: role of technology transfer. In *Construction Management and Economics*. Vol. 12. pp. 379-392.
- Tawiah, Owusu., 1999, *Factors Affecting the Performance of Ghanaian Owned Construction Firms*. Department of Building Technology. Faculty

of Environmental and Development Studies. Kwame Nkrumah University of Science and Technology. Kumasi. Ghana.

Wells, J., 2001. "Construction and capital formation in less developed economies: Unravelling the informal sector in an African city", in *Construction Management and Economics* ,London, Taylor & Francis Ltd., 19, pp. 267-274.