

Research trends in optical in-building networks

Citation for published version (APA):

Koonen, A. M. J., Lee, S. C. J., Yang, H., Jung, H. D., Tangdiongga, E., van den Boom, H. P. A., & Randel, S. (2009). Research trends in optical in-building networks. In *Lasers & Electro Optics & The Pacific Rim Conference on Lasers and Electro-Optics, 2009. CLEO/PACIFIC RIM '09, 31 August - 3 September, 2009, Shanghai, China* (pp. ThG2-4-1-2). Institute of Electrical and Electronics Engineers. <https://doi.org/10.1109/CLEOPR.2009.5292156>

DOI:

[10.1109/CLEOPR.2009.5292156](https://doi.org/10.1109/CLEOPR.2009.5292156)

Document status and date:

Published: 01/12/2009

Document Version:

Publisher's PDF, also known as Version of Record (includes final page, issue and volume numbers)

Please check the document version of this publication:

- A submitted manuscript is the version of the article upon submission and before peer-review. There can be important differences between the submitted version and the official published version of record. People interested in the research are advised to contact the author for the final version of the publication, or visit the DOI to the publisher's website.
- The final author version and the galley proof are versions of the publication after peer review.
- The final published version features the final layout of the paper including the volume, issue and page numbers.

[Link to publication](#)

General rights

Copyright and moral rights for the publications made accessible in the public portal are retained by the authors and/or other copyright owners and it is a condition of accessing publications that users recognise and abide by the legal requirements associated with these rights.

- Users may download and print one copy of any publication from the public portal for the purpose of private study or research.
- You may not further distribute the material or use it for any profit-making activity or commercial gain
- You may freely distribute the URL identifying the publication in the public portal.

If the publication is distributed under the terms of Article 25fa of the Dutch Copyright Act, indicated by the "Taverne" license above, please follow below link for the End User Agreement:

www.tue.nl/taverne

Take down policy

If you believe that this document breaches copyright please contact us at:

openaccess@tue.nl

providing details and we will investigate your claim.

Research Trends in Optical In-Building Networks

A.M.J. Koonen¹, S.C.J. Lee¹, H. Yang¹, H.-D. Jung¹, E. Tangdiongga¹, H.P.A. van den Boom¹, S. Randel²

¹COBRA Institute, Eindhoven University of Technology, P.O. Box 513, NL 5600 MB Eindhoven, The Netherlands

²Siemens AG, Corporate Technology, Information & Communications, Munich, Germany

E-mail: a.m.j.koonen@tue.nl

Abstract: By using optical fibre, a single in-building network can offer many broadband services to both wired and wireless terminals. Multi-level modulation and dispersion-robust radio-over-fibre techniques allow the use of cost-effective multimode silica or plastic fibre.

Keywords: in-building network, multimode fibre, multitone modulation, radio over fibre

1. INTRODUCTION

In ever more places FTTH access networks are bringing high capacity for communication to residential homes. The next challenge is to extend this capacity into the homes. A single optical fibre in-building network can replace the many separate networks which exist today for the in-door delivery of video, telephony, internet services, control of domestic appliances, etc. Such a fibre network can act as a universal in-door backbone network for the delivery of a wide set of high-speed services to wired as well as wireless user devices. Hence it is much more efficient regarding installation, operation, upgrading and maintenance than today's separate in-door networks (coaxial cable, twisted pair, Cat-5, ...). Regarding the fibre type, single-mode fibre (SMF) offers the ultimate performance due to its extremely large bandwidth and low losses, but is relatively costly to install as skilled personnel and high-precision tools are required. Multimode fibre with its larger core diameter is easier and thus cheaper to install; large-core polymer optical fibre (POF) is well-suited for do-it-yourself installation. However, due to modal dispersion multimode fibre (in particular with a step-index profile) has a reduced bandwidth, and all-optical splitting devices require a more delicate design as mode-selective losses have to be very small in order to avoid the intensity-proportional modal noise (leading to BER floors).

2. NETWORK ARCHITECTURE

The in-building fibre network may be laid out in two classes of architectures: point-to-point (P2P), or point-to-multipoint (P2MP). In the P2P architecture, individual fibres run from a central site (the home gateway or Home Communication Controller, HCC) to a wall outlet in each room. In the P2MP architecture, network splitting devices are used which enable sharing of (parts of) the fibre infrastructure by several wall outlets, thus saving on the costs of the fibre cable infrastructure. The P2MP topology may be a tree, bus, star, or hybrid combination of those. A more

detailed techno-economic analysis [1] shows that a P2P architecture using large-core POF may be preferred for smaller (residential) buildings, whereas a P2MP bus architecture using (bend-insensitive) SMF may be preferred for larger (professional) buildings. Based on SMF, power splitters and wavelength routers can readily be realised, which enables a P2MP all-optical network. Such a network is agnostic for the transported signal format, and hence the number and/or quality of the signals to be transported can easily be upgraded without modifying the network splitting nodes. On the other hand, it needs robust signal multiplexing techniques and medium access control strategies to allow the co-existence of multiple signals on the same fibre infrastructure. Alternatively, one may choose an opaque P2MP architecture, where in each network splitting node optical-electrical-optical signal conversion takes place, such as in IP hubs or IP routers. Such an opaque network is preferably IP-based, and does not support an efficient independent coexistence of multiple services with different signal formats (such as analogue video and digital data).

In the rest of this paper, we will mainly focus on the use of multimode (silica or polymer) optical fibre; this fibre type puts the largest challenges for conveying high-capacity signals within its limited bandwidth.

3. HIGH CAPACITY DATA OVER MULTIMODE FIBRE

By using advanced signal modulation techniques which deploy multiple amplitude and/or phase levels, the information content per transmitted symbol is increased and thus more information can be transmitted within a given bandwidth. E.g., a Quadrature Amplitude Modulation scheme with M signal constellation points (QAM- M) allows a throughput increase by a factor of $\log_2 M$. However, a larger M requires a smaller noise margin, and thus a higher signal-to-noise ratio (SNR). Given the restricted bandwidth of a multimode fibre, in particular of a large-core POF, the available SNR decreases at higher frequencies. Hence the limited bandwidth of the fibre can be most efficiently exploited by adaptive bit loading and power allocation techniques (similar to those in DSL systems) where multiple subcarrier frequencies are used and each subcarrier is modulated in QAM- M format with the constellation factor M being adapted to the SNR available at that subcarrier frequency. Using 80 subcarriers of which 40 are loaded with QAM-256 and 40 with QAM-64, and a 650nm DVD laser diode, 1Gbit/s has been transported over 100 metres of 1mm

core step-index PMMA POF [2]. In order to further reduce the system's costs and improve its robustness, a 650nm resonant-cavity LED was deployed together with Discrete Multitone (DMT) modulation techniques; see Fig. 1 [3]. Up to 256 carriers were used, loaded with QAM-8 up to QAM-64. Thus 1.106Gbit/s transmission has been achieved over 50 metres of 1mm core step-index PMMA POF. The DMT signal processing was done with off-line techniques; real-time implementations are currently being investigated. Using DMT techniques and a 1.3 μ m laser diode, even 40.6Gbit/s (45.8Gbit/s incl. overhead) over 100 metres of 50 μ m core perfluorinated POF has been achieved [4].

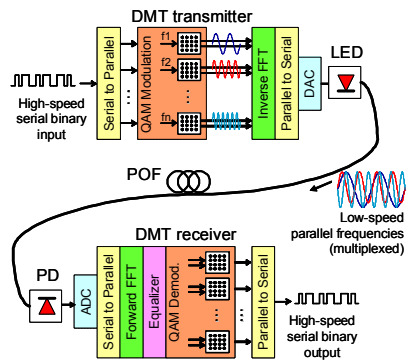

Fig. 1 1Gbit/s DMT transmission over 1mm core SI-POF

4. RADIO OVER MULTIMODE FIBRE

Next to delivery of high data rates to wired terminals, it becomes increasingly important to support wireless terminals (laptop computers, PDA-s, ...) as well. For delivering multi-Gbit/s data rates, microwave radio (e.g. 60GHz) and ultra-wideband radio techniques are being developed. In order to allow communication throughout a whole building, their pico-cell reach (up to 10 metres or less) can be extended by transporting the microwave signals over the in-door optical fibre backbone by means of radio-over-fibre (RoF) techniques. We developed the Optical Frequency Multiplying (OFM) technique which enables to generate very pure microwave carriers, and to transport these over dispersive fibre links, such as in multimode fibre networks [5]. The OFM technique is based on periodically sweeping the optical frequency of a laser diode. After data modulation and FM-to-IM conversion by an interferometric device, the signal is transmitted via fibre to the simplified antenna site (radio access point, RAP), where one of the higher-order harmonics is selected as the desired microwave carrier; see Fig. 2. This OFM process effectively suppresses the laser phase noise, and the resulting purity of the microwave carrier allows comprehensive signal modulation formats and thus high data rate wireless transport. Using OFM, we showed transmission of 16-QAM and 64-QAM signals up to 120Mbit/s on a single microwave carrier in the 24-30GHz band over 4.4km of silica 50 μ m core graded-index fibre [5]. Using up to 10 subcarriers, we also transported 210Mbit/s in 64-QAM over the same link. Using one carrier at 17.2GHz and QAM-16, we realized a 100Mbit/s bidirectional link at 1.3 μ m over 100 metres of 50 μ m core perfluorinated graded-index POF.

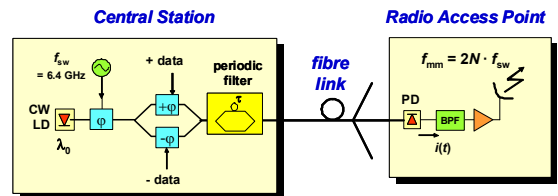

Fig. 2 Optical Frequency Multiplying

Dynamic routing of the RoF signals in the fibre backbone network enables the system to efficiently handle the mobility of users in a building. By means of tunable wavelength routing devices in the network nodes, or wavelength-tunable sources in combination with fixed-wavelength routing devices in the nodes, the RoF signals can be directed to those RAPs where the traffic load requires them. We demonstrated routing within a link of 950 metres of silica 50 μ m graded-index fibre by means of wavelength conversion using cross-gain modulation in a single SOA of a 1.5 μ m OFM 36Mbit/s 16-QAM 18.3GHz signal deploying 52 OFDM subcarriers (Fig. 3 [6]).

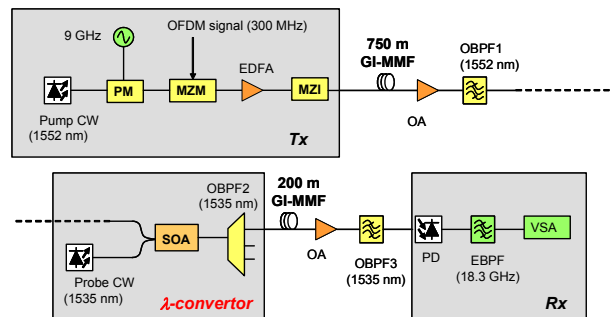

Fig. 3 Wavelength-routing of OFM RoF signal

5. CONCLUSIONS

Multimode fibre in-building networks can support the delivery of multi-Gbit/s services to wired terminals by means of multitone multilevel modulation, as well as high data rates to wireless terminals by the Optical Frequency Multiplying technique, optionally enhanced with optical routing.

Funding from the European Commission for this work performed in the FP7 ALPHA project is acknowledged.

REFERENCES

- [1] A.M.J. Koonen et al, "Optimisation of In-Building Optical Networks", submitted to ECOC'09
- [2] S. Randel et al, "1 Gbit/s Transmission with 6.3 bit/s/Hz Spectral Efficiency in a 100m Standard 1mm Step-Index Plastic Optical Fibre Link Using Adaptive Multiple Sub-Carrier Modulation", Proc. ECOC'06, Cannes, paper Th.4.4.1
- [3] S.C.J. Lee et al, "Low-Cost and Robust 1-Gbit/s Plastic Optical Fiber Link Based on Light-Emitting Diode Technology", Proc. OFC'08, San Diego, paper OWB3
- [4] H. Yang et al, "40-Gb/s Transmission over 100m Graded-Index Plastic Optical Fiber Based on Discrete Multitone Modulation", Proc. OFC'09, San Diego, paper PDPD8
- [5] A.M.J. Koonen, M. García Larrodé, "Radio-over-MMF Techniques – Part II: Microwave to Millimeter-Wave Systems", J. Lightw. Technol., Vol. 26, No. 15, Aug. 2008, pp. 2396-2408
- [6] H. Yang et al, "OFDM Radio-over-Fibre Systems Employing Routing in Multi-Mode Fibre In-Building Networks", Proc. ECOC'08, Brussels, paper Tu.4.F.6