

Analysis of power quality performance of the Dutch medium and low voltage grids

Citation for published version (APA):

Bhattacharyya, S., Wang, Z., Cobben, J. F. G., Myrzik, J. M. A., & Kling, W. L. (2008). Analysis of power quality performance of the Dutch medium and low voltage grids. In *13th International Conference on Harmonics and Quality of Power 2008 (ICHQP), Sept. 28 2008-Oct. 1 2008, Wollongong, NSW* (pp. 1-6). Institute of Electrical and Electronics Engineers. <https://doi.org/10.1109/ICHQP.2008.4668800>

DOI:

[10.1109/ICHQP.2008.4668800](https://doi.org/10.1109/ICHQP.2008.4668800)

Document status and date:

Published: 01/01/2008

Document Version:

Publisher's PDF, also known as Version of Record (includes final page, issue and volume numbers)

Please check the document version of this publication:

- A submitted manuscript is the version of the article upon submission and before peer-review. There can be important differences between the submitted version and the official published version of record. People interested in the research are advised to contact the author for the final version of the publication, or visit the DOI to the publisher's website.
- The final author version and the galley proof are versions of the publication after peer review.
- The final published version features the final layout of the paper including the volume, issue and page numbers.

[Link to publication](#)

General rights

Copyright and moral rights for the publications made accessible in the public portal are retained by the authors and/or other copyright owners and it is a condition of accessing publications that users recognise and abide by the legal requirements associated with these rights.

- Users may download and print one copy of any publication from the public portal for the purpose of private study or research.
- You may not further distribute the material or use it for any profit-making activity or commercial gain
- You may freely distribute the URL identifying the publication in the public portal.

If the publication is distributed under the terms of Article 25fa of the Dutch Copyright Act, indicated by the "Taverne" license above, please follow below link for the End User Agreement:

www.tue.nl/taverne

Take down policy

If you believe that this document breaches copyright please contact us at:

openaccess@tue.nl

providing details and we will investigate your claim.

Analysis of Power Quality Performance of The Dutch Medium And Low Voltage Grids

S. Bhattacharyya, Z. Wang, J. F. G. Cobben, J. M. A. Myrzik and W.L. Kling

Abstract-- Modern installations have become sensitive to power quality (PQ) related problems because more sophisticated devices with non-linear operating characteristics are often used there. On the contrary, most of these devices produce emissions that could decrease the PQ level of the network. It is becoming an increasing problem for the network operators to maintain good voltage quality because of the interactions of customer's loads with the grid. It is anticipated that the network's physical characteristics (e.g. short circuit power, grid impedance) can influence the PQ performance (harmonic distortion, flicker severity) in the distribution grid. In this paper, a typical modern medium and low voltage Dutch grid is described that is modelled in the analysis tool 'Power Factory'. The network is simulated to analyze grid impedance and short circuit powers at different parts of the network. Furthermore, the importance of grid impedance is analyzed in relation to PQ aspects at the customer's point of connection.

Index Terms— Dutch grid, PQ performance, flicker, total harmonic distortion, grid impedance, short circuit power.

I. NOMENCLATURE

PQ	:	Power Quality
POC	:	Point of connection
MV / LV	:	Medium / low voltage
PQM	:	Power quality monitoring
THD	:	Total harmonic distortion
Plt	:	Flicker severity (long term)
Pst	:	Flicker severity (short term)
S_{SC}	:	Short circuit power
Δu_{lim}	:	Rapid voltage change
Z_{ref}	:	Reference impedance
XLPE	:	Cross-linked poly ethylene cable

The work presented in this paper is part of the research project 'Voltage quality in future infrastructures'- ('Kwaliteit van de spanning in toekomstige infrastructuur (KTI)' in Dutch), sponsored by the Ministry of Economics Affairs of the Netherlands. Further information at: www.futurepowersystems.nl.

The authors' affiliations are as follows:

Ir. S. Bhattacharyya and Z. Wang are PhD student and master student respectively at TU/Eindhoven, the Netherlands, (e-mail: s.bhattacharyya@tue.nl, z.wang@student.tue.nl).

Dr. ir. J. F. G. Cobben is a part time assistant professor at TU/Eindhoven, the Netherlands, (email: j.f.g.cobben@tue.nl). Dr. ir. J. M. A. Myrzik is an assistant professor at TU/Eindhoven, the Netherlands (email: j.m.a.myrzik@tue.nl). Prof. ir. W. L. Kling is a part time professor at TU/Eindhoven, the Netherlands (email: w.l.kling@tue.nl).

II. INTRODUCTION

IN the last decade, the electricity as a product has become more competitive. Modern consumers use sophisticated devices that require high quality power supply. Moreover, the electrical devices have become more complex in terms of their functionalities and the way they interact with other devices present in the network. A strong regulation on the quality of the electric supply is required to optimize the electricity price while satisfying the customer's demand. Joint activities are going on among the regulators, utilities and research organizations from different countries to improve and optimize the European Standard EN50160, which is used for the MV and LV public grids for most of the European countries. The EN 50160 standard is issued by the European standardization body for electricity, CENELEC (European Committee for Electrotechnical Standardization). Recently, the committee members agreed that 95% limits of EN50160 standard should be replaced by stricter limits. Another proposal was made by the Italian regulators on setting minimum levels of short circuit power for the MV customers to restrict rapid voltage changes at the customer's terminals. It is expected that minimum short circuit power set will be useful for both the customer protection as well as for limiting the customer-originated disturbances [1].

Complaints on poor PQ are increasing every year among different types of customers. Large number of PQ disturbances can be originated at the customer premises because of the nonlinear operational behaviour of the customer's devices. The disturbances might get magnified depending on the network's configuration and location of the customer's POC in the grid. From various network analyses, it is observed that most of the polluting loads are connected at the MV and LV grids. A network's physical characteristics such as: short circuit power, grid impedance and load characteristics are important parameters that can influence PQ level in the grid [2]. Reference [3] shows that there can be definite relations among grid impedance, inrush current and flicker severity levels at the customer's POC. Hence, the network operator should specify maximum grid impedance and minimum short circuit power at each customer's POC to guarantee a definite PQ level at the connection point.

In the present electricity infrastructure of the Netherlands, two distinct types of medium and low voltage electricity grids are in operation. Along with the modern grid that is designed 5-10 years back, a significant part of the Dutch grid was

developed 40 years back and is still in operation. The old networks have relatively higher grid impedances compared to the modern Dutch network. In this paper, present PQ performance of the Dutch grid is discussed in brief; a typical modern MV and LV grid is modelled in the network analysis tool 'Power Factory' and the simulations are done to find out the grid impedance and short circuit power levels in different parts of the network.

III. DESCRIPTION OF THE DUTCH GRIDS

The Dutch grid can be divided mainly in three categories. The national grid that consists of 380kV and 220kV voltage levels with overhead lines; the regional grid with the voltage levels between 220kV and 25kV and consists of both overhead lines and cables; and the local grid that has voltage level below 25kV and are fed by cable networks.

The networks with voltage levels 25kV and lower are generally called distribution system. The Dutch medium voltage (MV) distribution grids largely consist of 10kV voltage networks and mostly have ring or meshed layout with a grid opening. The low voltage (LV) Dutch grids are fed by cables and are of radial layouts [4].

A. PQ monitoring activities in the Dutch grids

PQ monitoring has been recognized as an important tool to judge the performance level of the networks. From 1989, network operators of the Netherlands started to monitor 5th and 11th harmonics in their network. In 1996, the PQ monitoring (PQM) program had been extended for low, medium and high voltage networks at 150 locations throughout the country to measure PQ levels for a duration of one week in a year. The measurement was mainly done to assure that the Dutch grid meets the requirements of the standard EN50160 and the Dutch national 'Grid Code'. During the measurement: slow voltage variations, fast voltage variations, unbalance and harmonics data were recorded. In 2003, another PQ monitoring program (PQM II) was introduced to register the PQ events (voltage dips) data for a period of one year. In the PQM II, in addition to the above PQM program, a continuous monitoring was included for 20 permanent locations in the HV network along with all the connection points of extra high voltage networks. The PQ measurement points were selected carefully so that the monitoring results could be used as reference data for the Dutch network.

B. Present PQ performance of Dutch grids

From the surveys among the Dutch customers, it was found that the customers are quite satisfied with the present quality of the power supply and want to receive the same PQ level of the electricity in the future. However, the network operators get complaints on some specific PQ aspects. In the Netherlands, a survey was conducted by Laborelec and KEMA (during year 2004-2005) on various PQ problems among different Dutch customers. It was found that the main PQ complaints that are registered by the Dutch network operators are because of light flicker (31%), under voltage (25%), low voltage along with

flickering light (32%), over voltage (2%), voltage variations (2%) and other PQ related problems (8%) [5].

The results of the PQM programs during 1998 up to 2004 give an overview of the Dutch grid on the variations of voltage levels, flicker and total harmonic distortion levels. It is noticed from the measurements that the voltage level in the low voltage grid increases slightly over the years. It is mainly due to the changes and adoption of new voltage levels and tolerance limits in the Dutch grid. Also, the integration of distributed generations (DG) into the grid is considered as another reason of the growing trend of the voltage profile in the low voltage grid. The voltage unbalance is not yet a problem for the present Dutch grid at various voltage levels. The PQM results of flicker severity level (Plt) for LV grid (in 2006) are shown in Fig. 1. The flicker level of LV Dutch grid has a rising trend too [6]. Various PQ problems such as harmonics, flicker and unbalance are found more in the LV grid than in the MV and HV grids. It is because of the increasing use of disturbing loads comprising of high-power equipment and the new installation connections (without any supervision) in the LV grid.

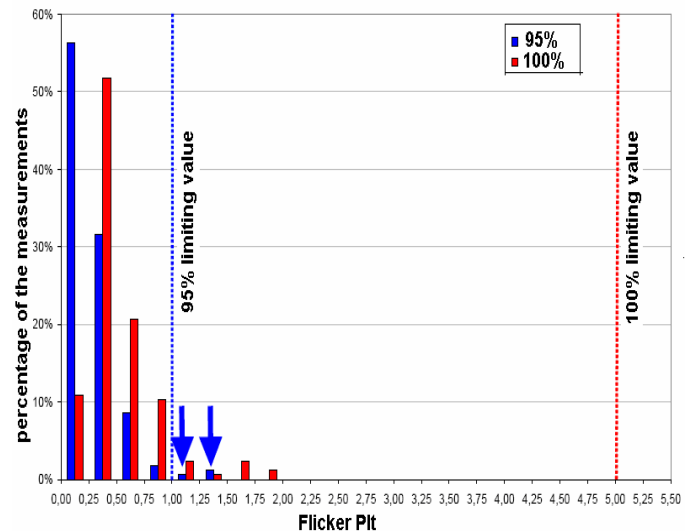

Fig. 1. Flicker severity level (Plt) for the LV grid [6]

The level of total harmonic distortion (THD) seems to be constant over the years in the Dutch LV grid. It is due to the fact that most of the LV and MV networks in the Dutch grid are cable-connected which have low inductive impedance. However, some local harmonic problems and resonance problems occur in the grid. The 95% average value of THD is around 2.5% for low and medium voltage grids. The transfer coefficients of harmonics voltages from LV to medium and high voltage levels are very small (less than 0.1). So, the distortion originating at LV level will be transferred at a lesser rate than that from the HV to LV grids [3].

C. Description of typical MV and LV Dutch grids

Several MV feeders for different Dutch network operators are analyzed to design an average MV Dutch grid. It was found that the short circuit power (S_{sc}) at the beginning of an outgoing feeder of a MV substation varies between 300-350

MVA across different provinces in the Netherlands. Two types of grid structures are identified:

- Short feeder of 8-10km length with congested loads
- Long feeder of 15-18km length with distributed loads

A typical modern Dutch MV substation consists of 15 MV feeders in average; and a MV feeder can have 15-25 transformer stations (of 10/0.4kV type) to feed different customers. From the analysis of various network's schematics, it is found that around 75% of the total MV/LV transformer stations feed to the household and small commercial customers and other 25% of them feed to large commercial and industrial customers. The distributions of MV / LV transformer stations along the MV feeders' lengths are shown in Fig. 2.

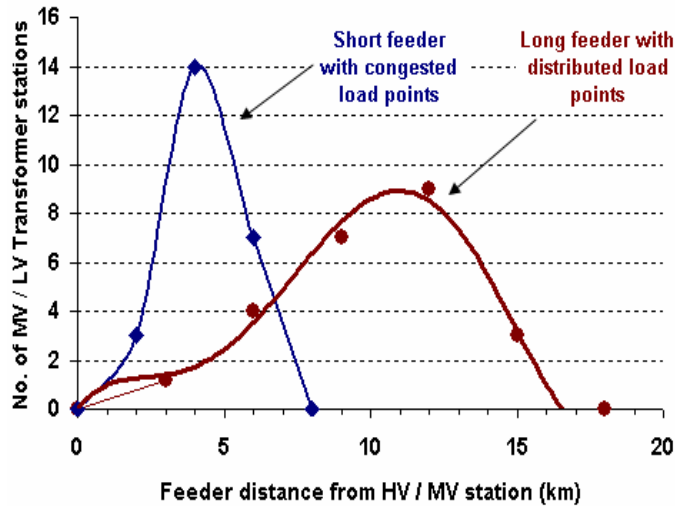

Fig. 2. Distribution of transformer stations across MV feeder length

In Fig. 2, two types of case study results are shown. It can be noticed that for a long feeder case (which is probably feeding to the rural areas or small cities with diversely distributed loads), the customer's load points are distributed relatively evenly along the feeder length. On the contrary, for a short feeder (which is probably feeding to a big city with congested load points), majority of the transformer stations are located close to each other and have maximum density at the distance between 3-6 km from the MV substation.

For modelling of an average MV feeder, the feeder length is considered as 12 km with an average current loading of 180A (\equiv 3.2 MW equivalent). The typical rating of a MV / LV transformer is 400kVA that feeds to the household customers (single phase 40A load); small commercial customers (maximum demand of 50kVA) or the combination of both. When the LV supply is fed to multiple large commercial or small industrial customers of the load demand 160kVA or more, a transformer of 630kVA rating is used. If a customer's load demand is 200kVA or more, then the customer should have his own cables and transformers. From the analysis of network schematics of different Dutch network operators, the load distribution in a MV feeder length for different customer types are estimated in Table I.

TABLE I: LOAD DISTRIBUTION IN A TYPICAL MV FEEDER

No. of transformers	Customer type (by each transformer)	Average Demand (kVA)
9 nos. @400 KVA	150 households	1420
4 nos. @400 KVA	80 households + 3 small commercial (@ 30kVA average demand)	700
1 no. @ 630 KVA	4 large commercial (@ 100kVA average demand)	400
3 nos. large customers, fed by their own transformers	industry / large commercial (@ 250kVA average demand)	750

Note: Average demand of household is 1kW, with power factor of 0.95

In our design, we have considered that there are 3 large customers having their own transformers; 13 MV/LV transformers of 400kVA capacity; and a 630kVA MV/LV transformer present in the MV feeder as shown in Table I.

Each 400kVA transformer consists of minimum four LV feeders. The cables of 150 mm² aluminium conductor with XLPE insulation are commonly used. The average length of a LV feeder is 550m, when feeding to household customers only. In Fig. 3, typical LV feeders feeding to various customers are shown.

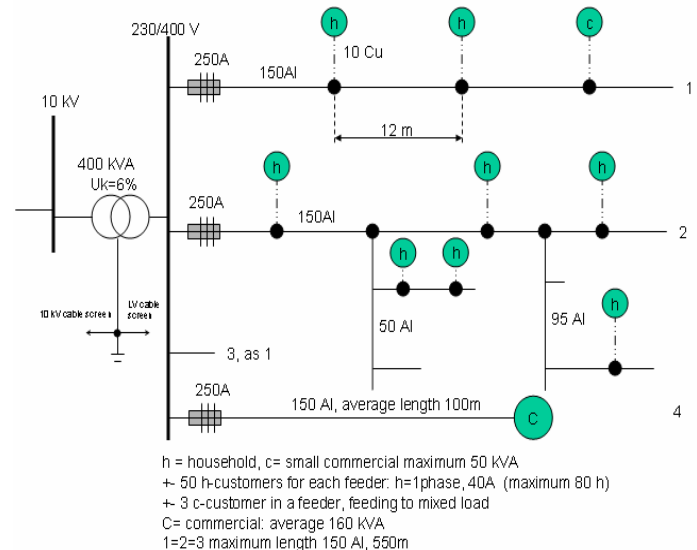

Fig. 3. Typical schematic of a Dutch LV feeder

A typical LV feeder can serve to 40-50 household customers, and is of radial configuration either with a single branch or with multiple branches (as shown in Fig. 3).

In a MV feeder, different types of customer's loads are connected (refer Table I). A typical schematic of a modern Dutch MV feeder and its loads is presented in Fig. 4. The following assumptions are made in designing the network:

- Total possible load of a typical household customer is 10kW. A diversity factor of 10% is assumed for their simultaneous operation at a time. So, average demand of each household customer is 1kW (single phase).
- For the simplification in simulation, three household

loads are combined as a lumped 3-phase load.

- The short circuit power of the MV station is 300 MVA.
- The average distances between two consecutive MV nodes are taken as 1.2km.
- The distance between the first house and MV/LV transformer station is taken as 100m; and the distance between two consecutive houses is considered as 12m.
- Transformers (400kVA) that feed to household / small commercial customers or both are loaded by 40-50% of their nameplate rating (typical Dutch scenario as found from the statistics of the network operators).
- Transformers (630kVA) that feed to large commercial or industries are loaded by 65-70% of their capacity.
- The model is made flexible which makes it possible to move typical customers to other places in the network.
- Static load modelling is used in the ‘Power Factory’ for describing the relation of active (P) and reactive power (Q) with the voltage (V) at any instant of time and is shown in (1) [8].

$$P = P_0 \cdot V^\alpha ; Q = Q_0 \cdot V^\beta \quad (1)$$

where, α = active power exponent, β = reactive power exponent, P_0 = active power at the operating point and Q_0 = reactive power at the operating point.

In Fig. 4, a typical MV feeder of a modern Dutch grid is shown that is modelled in ‘Power Factory’. The customer’s load points are indicated in different colours. There are 3 locations where large industrial customers (shown in orange) are connected, 9 locations (shown in pink) for household customers only; 4 locations (shown in green) where both households and small commercial customers are connected; and 1 location for large commercial customer (shown in maroon).

- The industrial load is related to industrial processes that correspond to the usage of 95% industrial motors that demands constant torque.
- The household load includes most of the devices related to home appliances but also may include electric heating and air conditioner for seasonal use.
- The commercial load corresponds to air conditioner units and a large percent of discharge lighting.

The voltage dependent load models for household, industrial, and commercial loads are adopted from [8] and are shown in Table II.

TABLE II: LOAD TYPE AND EXPONENT VALUES [8]

Load Type	α	β
Residential	0.92	4.04
Commercial	1.51	3.40
Industrial	0.18	6.00

D. Grid impedance in relation to PQ level

Grid impedance is an important parameter for determining several PQ aspects in a network. At present there are no general standards or requirements with regard to impedance. High grid impedance can contribute to harmonic voltages, high frequency noise, and high flicker severity. On the contrary, low grid impedance will not be able to limit short circuit currents and may cause noises as well as mechanical stresses in the conductor [7].

It is noticed that more disturbing loads are getting connected to the network at the customer’s sites. So, it may happen that the customer’s disturbing load is connected at a place that is not suitable for a specific network configuration. Furthermore, if several disturbing loads are connected near to each other and have similar type of non-linear characteristics and are operating simultaneously, the disturbance produced by those loads can be high enough and may exceed the standard limits (of connection rules). Thus, the positioning of the disturbing loads at a customer’s installation can increase PQ disturbances in the network. When a load is connected in the network, the emission limit of the disturbing load is to be calculated in relation to the grid impedance.

In 1980, the statistics for reference grid impedance (Z_{ref}) for

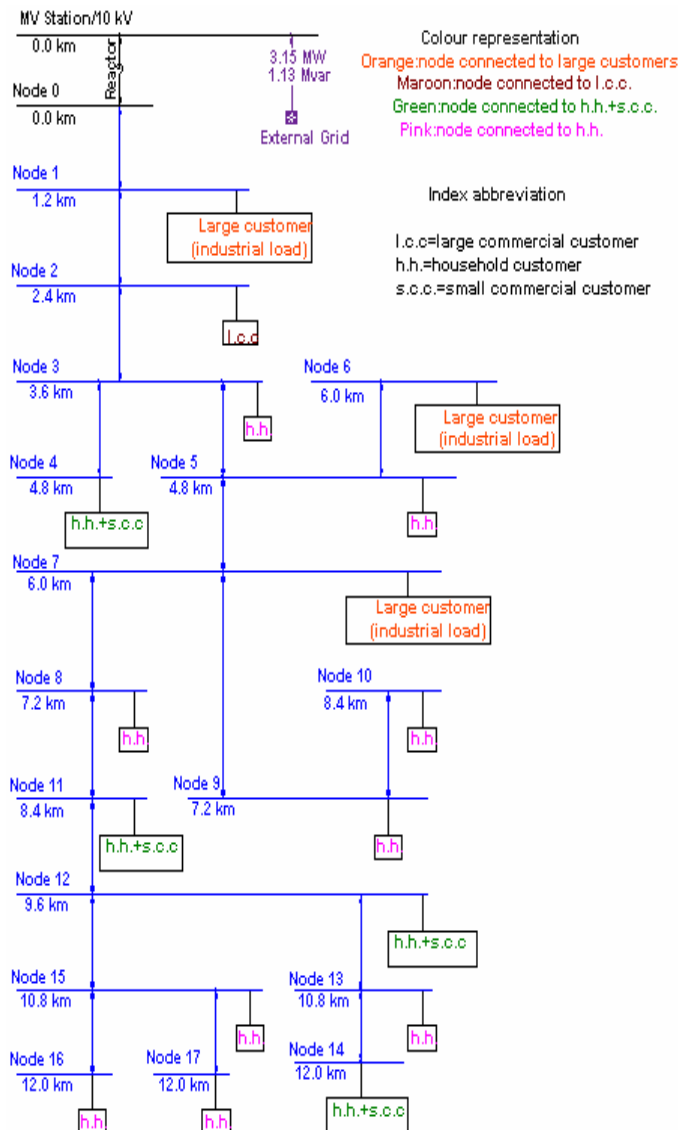

Fig. 4. Typical 10kV MV feeder modelled in ‘Power Factory’

the single-phase connections in the low voltage public network in the Netherlands was published as shown in Table III:

TABLE III: REFERENCE LV GRID IMPEDANCE DATA [5]

	Percentage of the network users for whom the network impedance should be less than equal to the following value		
	95%	90%	85%
Impedance (phase-neutral)	$0.70 + j 0.25 \Omega$	$0.41 + j 0.21 \Omega$	$0.32 + j 0.17 \Omega$

The above grid impedance data was recommended 28 years back. It is possible that the network impedance in the modern grid is lower than the above values because of the improvement of the network infrastructure in the Netherlands. So, when estimating average grid impedance for the LV Dutch networks, the influences of both old and modern grids should be considered. In the standard IEC 61000-3-3, the reference impedances of the LV grid are given as follows:

$$\text{Phase impedance} = 0.24 + j 0.15 \text{ ohm (at 50Hz)} = 0.283 \Omega$$

$$\text{Neutral impedance} = 0.16 + j 0.10 \text{ ohm (at 50 Hz)}$$

$$\text{So, Phase-neutral impedance} = 0.40 + j 0.25 \text{ ohm} = 0.472 \Omega$$

If the nominal current of a device is equal to or less than 16A, the standard IEC 61000-3-3 is used for its connection rules, whereas if the nominal current is between 16A and 75A, the devices are made according to the standard IEC 61000-3-11. In IEC 61000-3-11, there are two options while connecting a device in the network. The first option is to have a contracted current of 100A or more per phase at the customer's terminal, when supplied from a 400/230 V distribution network. The device should be clearly marked in this way and the customer should determine in consultation with the network operator that the service capacity at the POC is sufficient for the device. The other possibility in IEC 61000-3-11 is to determine the maximum permissible system impedance at the POC. If the device is not made according to IEC 61000-3-3 or IEC 61000-3-11, the customer has to determine in consultation with the network operator whether the connection requirements are still fulfilled by connecting the device [3].

For different connection types in a typical LV Dutch grid, maximum grid impedances can be calculated considering that the allowable inrush current is equal to the nominal current of the protection device at the POC. The calculated values of maximum grid impedances are shown in Table IV [3], to limit the inrush current and restrict ΔP_{st} to 1 as per IEC 61000-3-3.

TABLE IV: MAXIMUM IMPEDANCE FOR VARIOUS CONNECTIONS

Connection type	Amperage (Amp)	Maximum grid impedance per phase (Ω)
3 phases + neutral	25	0.523
3 phases + neutral	40	0.326
3 phases + neutral	50	0.261
3 phases + neutral	63	0.207
3 phases + neutral	80	0.163

IV. SIMULATION RESULTS

A. Distribution of grid impedance along the feeder length

With the vertical structure of the electricity network (when no distributed generator is connected at the MV and LV grids), the short circuit power (S_{SC}) decreases along the MV feeder length (maximum at a point close to the feeding station; and minimum at the furthest end of the feeder), as shown in Fig. 5.

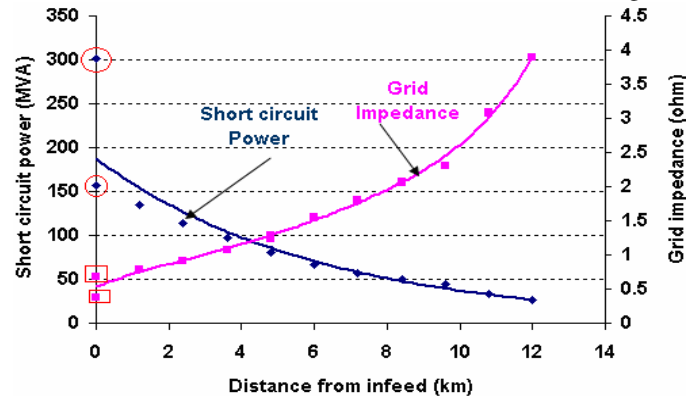

Fig. 5. Distribution of S_{SC} and Z along a MV feeder length

Fig. 5 shows that the grid impedance and short circuit power (S_{SC}) have two values at the beginning of the feeder that represents two different node points: one for the 10kV station and other for Node 0 in Fig. 4. A series reactor is present in the feeder near to the MV station, to restrict the S_{SC} entering into the feeder. At the beginning of the MV feeder, the S_{SC} is 300 MVA that decreases to 26 MVA at the end; while grid impedance at the beginning of the MV feeder is 0.37 ohm and is increased to 3.9 ohm at the furthest end of the MV feeder (when the impedance values are referred to MV level).

It is also interesting to check the distribution of the grid impedance along a LV feeder length of the simulated network. The distributions of grid impedances along the LV feeder for various LV customers, fed from two different MV nodes (e.g. 'Node 3' which is located near to the MV station; while 'Node 17' which is far away from the MV station), are compared in Fig. 6. The maximum grid impedance per phase found at the furthest end of the LV grid is 0.2 ohm; while the maximum permissible value of reference impedance per phase in the LV grid is 0.283 ohm as per IEC 61000-3-3. However, some LV customers have higher grid impedance than the value indicated in Table IV (e.g. for 80A connection). It means that at those locations the inrush current of the customer's load is to be adjusted proportionately as shown in (2), to restrict P_{st} level.

$$I_{new,in} = \frac{Z_{ref}}{Z_{actual}} * I_{ref,capacity} \quad (2)$$

The new inrush current ($I_{new, in}$) will be calculated by multiplying the reference capacity current ($I_{ref, capacity}$) with a factor of the reference grid impedance (Z_{ref}) and the actual measured grid impedance (Z_{actual}) at the POC. So, when giving a connection to a customer, the network operator should check the connection's amperage to ensure good PQ level at a POC.

In a MV grid, the impedance of a MV/LV transformer is high compared to MV cable impedances. The grid impedances

calculated at the LV sides of different MV/LV transformer stations along a MV feeder are comparable. Therefore, the impedances of the LV cables (i.e. the location of the customer in the LV grid) have significant influences in determining the grid impedance at the LV customer's POC.

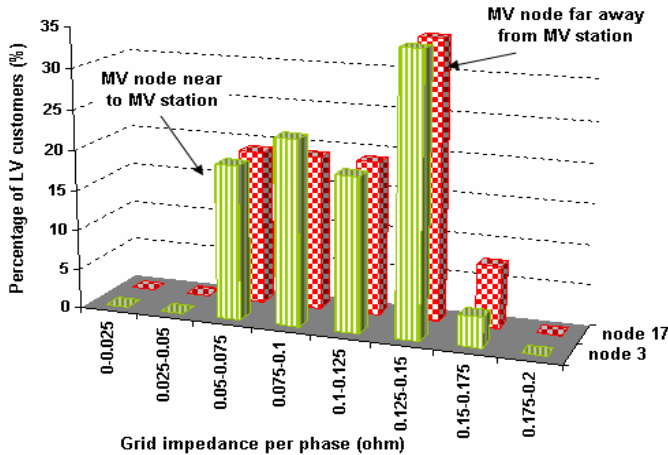

Fig. 6. Distribution of grid impedance per phase at LV customer's terminals

From Fig. 6, it can be seen that most of the LV customers confirm to the connection requirements of the IEC 61000-3-3 standard as well as Table IV, regarding the grid impedance.

B. Distribution of customer's POC and short circuit power

Short circuit power in the electrical network is an important concept in PQ. The voltage fluctuations and flicker level are dependent on the impedance of the network at the customer's POC, which is related to short circuit power ($S_{SC} = \text{Voltage}^2 / \text{Impedance}$). The information on maximum value of S_{SC} at any point in the network is mainly useful for protection coordination in the network and equipment sizing, while the knowledge of minimum value of S_{SC} at a connection point is needed for coordinating protection between the network operator and the customer and for evaluating PQ levels. The calculation of the minimum short circuit power (S_{SC} in MVA) at a MV customer's POC and a MV/LV transformer's terminal (S_{trafo} in MVA) are suggested in the paper [1]. A co-relation as shown in (3) is suggested by the Italian researchers based on a preliminary estimation for the Italian networks [1], for a rapid voltage change of 5% ($\Delta u_{lim} = 0.05$) as per EN50160.

$$S_{SC} = 1.3 * \frac{\sqrt{S_{trafo}}}{\Delta u_{lim}} \quad (3)$$

In the modelled network, two types of transformers are present: a) 400kVA and b) 630kVA. By using (3), the minimum S_{SC} at the MV/LV station found is 16.4 MVA (for 400kVA) and 20.6 MVA (for 630kVA). If the rapid voltage change is restricted to 3% only, the minimum S_{SC} would be 27.4 MVA (for 400kVA) and 34.4 MVA (for 630kVA) respectively. The distributions of S_{SC} across various MV/LV transformer stations, feeding to different LV customer's points in the modelled network, are shown in Fig. 7. The lowest S_{SC} found in the modelled network is 25 MVA which is still higher than the calculated minimum S_{SC} for 5% rapid voltage change. But when rapid voltage change limit is restricted to 3% (as in

the Dutch Grid Code), some nodes in the modelled network do not confirm to the minimum S_{SC} limit requirements. Hence, PQ problems can be expected in some locations of the Dutch grid.

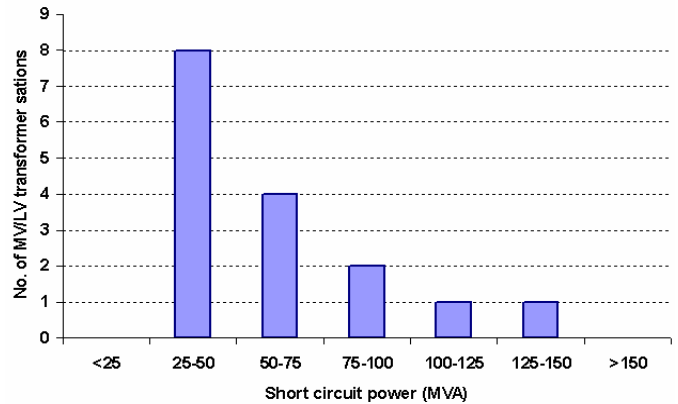

Fig. 7. Distribution of MV/LV transformer station with S_{SC}

C. Conclusion

In this paper, a typical model of the modern MV and LV grid of the Netherlands is presented. The distributions of short circuit power and grid impedance along the MV and LV networks are analysed. It is found that most of the LV customers confirm to the connection requirements of the IEC 61000-3-3 standard, regarding grid impedance at the POC. The lowest short circuit power found at the MV /LV transformer's terminal is higher than the minimum short circuit power requirement for 5% rapid voltage change. However, it might exceed in some cases when the rapid voltage change is limited to 3% and therefore PQ problems can be expected in some locations of the Dutch grid.

In the next phase of this research, the non-linear behaviour of the customer's loads would be included in the model. With background PQ pollutions (e.g. flicker and harmonic currents), the performance of the network will be further analysed.

V. REFERENCES

- [1] V. Allegranza, A. Ardito, E. De Berardinis, M. Delfanti, and L. Lo Schiavo, "Assessment of short circuit power levels in HV and MV networks with respect to power quality," presented in 19th International Conference on Electricity Distribution (CIRED), Vienna, May 2007.
- [2] G. Nicholson, V. Gosbell, and A. Parsotam, "The influence of site physical characteristics on power quality performance," proceedings of Australasian Universities Power Engineering Conference (AUPEC), Melbourne, Australia, 2006 (paper no. 34).
- [3] J. F. G. Cobben, "Power quality. Implications at the Point of Connection", Ph.D. dissertation, Dept. Electrical Engineering, Technical University of Eindhoven, the Netherlands, June 2007.
- [4] Jan de Jong, "ELEP: European local electricity production work package 2 – commercial & market policy issues", Deliverable 2.2, April 2006, contract. EIE/04/175/S07.38664.
- [5] Laborelec and KEMA T&D Consulting, "Power quality op het Aansluitpunt -fase I: inventarisatie en probleembeschrijving", February 2006, doc. no.40530061-TDC05-54719A (available in Dutch language).
- [6] R. Luiten, and E. .L. M. Smeets, "Spanningskwaliteit in Nederland in 2006", in opdracht van EnergieNed, sectie netbeheerders, juni 2007, doc. no. 30610502-consulting 07-1088 (available in Dutch language).
- [7] M. J. Russell, "The impact of mains impedance on power quality", presented at Power Quality 2000 (Boston, MA) on October 4, 2000.
- [8] IEEE Task Force on Load Representation for Dynamic Performance, "Bibliography on load models for power flow and dynamic performance simulation," IEEE Trans. Power Syst., vol. 10, no. 1, pp. 523–538, February. 1995.