

## Influence of phosphorus on the structure and the catalytic activity of sulfided Co-Mo catalysts

**Citation for published version (APA):**

Mangnus, P. J., Beer, de, V. H. J., & Moulijn, J. A. (1990). Influence of phosphorus on the structure and the catalytic activity of sulfided Co-Mo catalysts. *Applied Catalysis*, 67(1), 119-139. [https://doi.org/10.1016/S0166-9834\(00\)84436-X](https://doi.org/10.1016/S0166-9834(00)84436-X)

**DOI:**

[10.1016/S0166-9834\(00\)84436-X](https://doi.org/10.1016/S0166-9834(00)84436-X)

**Document status and date:**

Published: 01/01/1990

**Document Version:**

Publisher's PDF, also known as Version of Record (includes final page, issue and volume numbers)

**Please check the document version of this publication:**

- A submitted manuscript is the version of the article upon submission and before peer-review. There can be important differences between the submitted version and the official published version of record. People interested in the research are advised to contact the author for the final version of the publication, or visit the DOI to the publisher's website.
- The final author version and the galley proof are versions of the publication after peer review.
- The final published version features the final layout of the paper including the volume, issue and page numbers.

[Link to publication](#)

**General rights**

Copyright and moral rights for the publications made accessible in the public portal are retained by the authors and/or other copyright owners and it is a condition of accessing publications that users recognise and abide by the legal requirements associated with these rights.

- Users may download and print one copy of any publication from the public portal for the purpose of private study or research.
- You may not further distribute the material or use it for any profit-making activity or commercial gain
- You may freely distribute the URL identifying the publication in the public portal.

If the publication is distributed under the terms of Article 25fa of the Dutch Copyright Act, indicated by the "Taverne" license above, please follow below link for the End User Agreement:

[www.tue.nl/taverne](http://www.tue.nl/taverne)

**Take down policy**

If you believe that this document breaches copyright please contact us at:

[openaccess@tue.nl](mailto:openaccess@tue.nl)

providing details and we will investigate your claim.

# Influence of phosphorus on the structure and the catalytic activity of sulfided carbon-supported Co-Mo catalysts

P.J. Mangnus

*Department of Chemical Engineering, University of Amsterdam, Nieuwe Achtergracht 166, 1018 WV Amsterdam (The Netherlands)*

V.H.J. de Beer

*Laboratory for Inorganic Chemistry and Catalysis, Eindhoven University of Technology, P.O. Box 513, 5600 MB Eindhoven (The Netherlands)*

and

J.A. Moulijn<sup>1\*</sup>

*Department of Chemical Engineering, University of Amsterdam, Nieuwe Achtergracht 166, 1018 WV Amsterdam (The Netherlands)*

(Received 7 June 1990, revised manuscript received 21 August 1990)

## Abstract

The influence of phosphorus (added as phosphates) on the sulfiding rate of carbon-supported Co-Mo catalysts is studied by means of temperature-programmed sulfiding. Significant progress is made in understanding the influence of phosphates on the structure and thiophene hydrodesulfurization (HDS) activity (atmospheric pressure) of carbon-supported Co-Mo catalysts. The model compound  $\text{Co}_3(\text{PO}_4)_2 \cdot 8\text{H}_2\text{O}$  is sulfided to minor extent below 800 K. Between 800 and 1000 K, instead of further sulfiding, this compound is reduced to a mixture of CoP and  $\text{Co}_2\text{P}$ . Phosphates have a large influence on the structure and sulfiding rate of carbon-supported oxidic cobalt and Co-Mo catalysts. Addition of phosphates to these catalysts results in the formation of "Co- $\text{PO}_4$ " species which are, compared with other cobalt species, relatively difficult to sulfide. Between 650 and 800 K cobaltphosphate species are not sulfided but reduced to cobaltphosphides while disperse sulfided cobalt species react with  $\text{P}_2\text{O}_5$  and hydrogen to phosphides, water and hydrogen sulfide. These cobalt sulfide species are formed upon sulfiding of CoO,  $\text{Co}_3\text{O}_4$ , cobalt nitrates or cobalt species surrounded by a small number of phosphates. The sulfiding of the Mo/C catalyst is hardly influenced by the presence of phosphates. The poisoning of the low-pressure thiophene HDS activity of carbon-supported cobalt and Co-Mo catalysts by phosphorus can be explained by either the formation of "Co- $\text{PO}_4$ " species or CoP and  $\text{Co}_2\text{P}$ . Which of these explanations is valid depends on the reaction time and conditions. After short reaction times at 673 K, the major part of the cobalt species is present as "Co- $\text{PO}_4$ ", whereas the amount present as phosphides increases with reaction time. The Mo/C catalysts are most likely poisoned by phosphorus due to chemisorption of elemental phosphorus (P or  $\text{P}_4$ ) on sulfur anion vacancies present on the edges of the  $\text{MoS}_2$  slabs.

<sup>1</sup>Present address: Faculty of Chemical Technology and Materials Science, Delft University of Technology, Julianalaan 136, 2628 BL Delft, The Netherlands, Fax. (+31-15)784452.

*Keywords:* sulphidization, phosphorus-cobalt-molybdenum, hydrodesulphurization, catalyst characterization (TPS).

## INTRODUCTION

CoO–MoO<sub>3</sub>/Al<sub>2</sub>O<sub>3</sub> and NiO–MoO<sub>3</sub>/Al<sub>2</sub>O<sub>3</sub> catalysts are the most “popular” and best studied hydrotreating catalysts. Despite the high activity of these catalysts, there have always been new motives to improve their performance. The two main reasons for the continuous demand for improved hydrotreating catalysts are the continuously increasing restrictions of sulfur and nitrogen oxide emission and increasing need of processing low-quality crude oil. Addition of phosphorus to alumina-supported catalysts has shown to be beneficial for the hydrodesulfurisation (HDS) [1–4] and especially for the hydrodenitrogenation (HDN) activity [5–7]. Apart from some general observations as e.g., increase of the metal dispersion [2,3,8–10], decrease of coke formation [11] and increase of the thermal stability [12], the precise influence of phosphorus on the catalyst structure is still a matter of discussion. Especially the different influence of phosphorus on the HDS and HDN activity is puzzling. Observations reported by Topsøe et al. [13], Eijsbouts et al. [6] and Mangnus et al. [8] form a basis to unravel this question.

In contrast with the promotive effect of phosphorus on alumina-supported catalysts, addition of phosphorus to carbon-supported catalysts resulted in effective poisoning of the HDS activity [9,14–16] whereas the HDN activity increased or decreased depending on the metal(s) used [17,18]. Several explanations have been put forward to understand this effect viz., formation of HDS-inactive metalphosphates [9,10], metalphosphides or metalphosphosulfides [17,18] and the adsorption of PH<sub>3</sub> on the anion vacancies [16].

In order to understand the influence of phosphorus on the HDS and HDN activity of alumina- and carbon-supported catalysts, a more detailed picture of the surface structure of these phosphorus-promoted catalysts is needed. Despite the fact that carbon-supported and, a fortiori, poisoned catalysts are not of direct commercial interest, elucidation of the influence of addition of phosphates on the sulfidability and structures before and after sulfiding of these catalysts could be helpful to increase our knowledge of the phosphorus-promoted alumina-supported hydrotreating catalysts. Since in the latter catalyst all the transition metal and phosphate species are relatively strongly interacting with the alumina support, the influence of phosphate on the cobalt and molybdenum surface species, both before and after sulfiding is disguised. Systems in which these strong interactions are absent viz., model compounds and carbon-supported catalysts can therefore give more direct information about the interaction between phosphate, cobalt and molybdenum. Therefore, in this study, we focussed on carbon-supported catalysts. Recently, these catalysts

have been studied by Bouwens and co-workers [9,16] and Ramselaar et al. [10]. Besides by means of a thiophene HDS activity test, they characterised these and similar catalysts with X-ray photoelectron spectroscopy (XPS), carbon monoxide chemisorption and Mössbauer spectroscopy.

A high density of structural information can be obtained by using a combination of temperature-programmed reduction (TPR) and temperature-programmed sulfiding (TPS). However, in the case of carbon-supported catalysts the reactivity of hydrogen towards carbon, especially in the presence of reducible cobalt and molybdenum compounds which are hydrogenation catalysts, limits the potential of TPR. Despite the presence of hydrogen in the sulfiding mixture, TPS can be used to study carbon-supported catalysts since no metallic cobalt or molybdenum sites are formed even at elevated temperatures, which makes gasification of the carbon support less likely, since cobalt and molybdenum sulfides are not as good in catalyzing hydrogenation as cobalt and molybdenum. The gasification of carbon is also retarded due to the presence of hydrogen sulfide which blocks hydrogen dissociation sites.

## EXPERIMENTAL

### *Catalyst preparation*

Norit RX3-Extra is used as carbon support (BET surface area 1190 m<sup>2</sup>/g, pore volume 1 cm<sup>3</sup>/g). (NH<sub>4</sub>)<sub>6</sub>Mo<sub>7</sub>O<sub>24</sub>·6H<sub>2</sub>O (Merck), Co(NO<sub>3</sub>)<sub>2</sub>·6H<sub>2</sub>O (Merck), Co<sub>3</sub>(PO<sub>4</sub>)<sub>2</sub>·8H<sub>2</sub>O (Alpha Ventron) were used as metal precursors. Aqueous H<sub>3</sub>PO<sub>4</sub> (85 wt.-%, Janssen Chimica) is used as phosphorus-containing compound.

The Co-P, Mo-P and Co-Mo-P catalysts were prepared by first adding phosphoric acid to the support. After drying at 383 K, cobalt and molybdenum were introduced by pore volume impregnation. The Co-Mo catalysts were prepared by sequentially adding molybdenum and cobalt (molybdenum first). One of the Co-P/C catalysts is prepared by adding cobalt and phosphorus simultaneously, namely as Co<sub>3</sub>(PO<sub>4</sub>)<sub>2</sub>·8H<sub>2</sub>O. All carbon-supported catalysts were dried at 383 K, otherwise this will be indicated. Further details of preparation of the carbon-supported catalysts are given elsewhere [9,10,16].

The catalyst will be denoted by the number of cobalt, molybdenum or phosphorus atoms per nm<sup>2</sup> initial support surface area, a slash indicates separate impregnation steps, e.g. Mo(0.41)/P(0.14)/C contains 0.41 molybdenum atoms/nm<sup>2</sup> and 0.14 phosphorus atoms/nm<sup>2</sup> and phosphorus is introduced at first. When the catalyst is dried at 473 K, this temperature is added to the catalyst notation like, Co(0.37)/C-473. The catalysts studied are listed in Table 1.

TABLE I  
Catalysts applied

Catalysts	Cobalt content		Molybdenum content		Phosphorus content	
	(wt.-%)	(atoms/nm <sup>2</sup> )	(wt.-%)	(atoms/nm <sup>2</sup> )	(wt.-%)	(atoms/nm <sup>2</sup> )
P(1.71)/C	—	—	—	—	8.81	1.71
Co(0.37)/C	4.1	0.37	—	—	—	—
Co(0.40)/P(0.20)/C	4.3	0.40	—	—	1.11	0.20
Co(0.41)/P(0.13)/C	4.4	0.41	—	—	0.75	0.13
Co(0.66)P(0.44)/C <sup>a</sup>	6.7	0.66	—	—	2.35	0.44
Mo(0.41)/C	—	—	7.0	0.41	—	—
Mo(0.41)/P(0.14)/C	—	—	6.9	0.41	0.75	0.14
Co(0.26)/Mo(0.37)/C	2.6	0.26	6.1	0.37	—	—
Co(0.27)/Mo(0.48)/P(0.22)/C	2.6	0.27	7.6	0.48	1.1	0.22

<sup>a</sup>Prepared by using Co<sub>3</sub>(PO)<sub>4</sub>·8H<sub>2</sub>O.

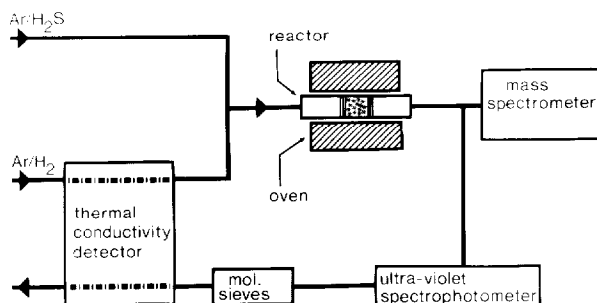

Fig. 1. Scheme of TPS apparatus.

### TPS

A scheme of the TPS apparatus used is shown in Fig. 1. A detailed description can be found in ref. 19. The sulfiding mixture consisted of 3.3% hydrogen sulfide, 28% hydrogen and 68.7% argon. The flow-rate was  $11 \cdot 10^{-6}$  mol/s. After an isothermal sulfiding step of 900 s at room temperature, the reactor was heated with a rate of 0.167 K/s up to 1273 K. The amount of catalyst used varied between 0.05 and 0.1 g, depending on the metal content of the catalyst. The quantitative data given in Table 2 are all normalised to a standard quantity of 0.1 g catalyst.

The hydrogen, hydrogen sulfide and water concentrations have been measured with a thermal conductivity detector (hydrogen), a UV-spectrophotometer (hydrogen sulfide) and a mass spectrometer (water, hydrogen sulfide). The hydrogen sulfide concentrations reported are acquired with the UV-spectrophotometer. Because of the greater stability of the UV signal as compared to the mass spectrometer signal, the quantitative data are calculated on the basis of the UV signal. The mass spectrometer is only used to make a correction on the UV signal when the hydrogen sulfide concentration exceeds the range where Lambert-Beer's law can be applied. In Figs. 2–6 a production peak is indicated as a peak in positive direction (both for hydrogen sulfide and hydrogen).

### TGA

Thermogravimetric analyses have been performed using a Setaram TG85 thermobalance. The sample was heated from 300–675 K at 0.083 K/s in a flow of argon. The thermobalance was coupled to an IBM PC-AT which collected the weight and temperature data. From the weight data, the rate of weight loss (DTA-signal) was calculated as a function of temperature.

TABLE 2

## Quantitative data

All data in this table are normalised to a standard quantity of 0.1 g

Catalysts	H <sub>2</sub> S uptake theoretical <sup>a</sup> ( $\mu\text{mol}$ )	H <sub>2</sub> S uptake up to 500 K ( $\mu\text{mol}$ )	H <sub>2</sub> S production 500-600 K ( $\mu\text{mol}$ )	H <sub>2</sub> S uptake up to 1273 K ( $\mu\text{mol}$ )	H <sub>2</sub> /P ratio <sup>b</sup>	H <sub>2</sub> S uptake/H <sub>2</sub> S theoretical uptake up to 1270 K <sup>c</sup> ( $\mu\text{mol}/\mu\text{mol}$ )
Co <sub>3</sub> (PO <sub>4</sub> ) <sub>2</sub> ·8H <sub>2</sub> O	522.0	0	0	0	3.4 ± 0.1	0
P(1.71)/C	—	0	0	0	1.0 ± 0.1	—
Co(0.37)/C	61.8	219	136	83	—	1.34
Co(0.41)/P(0.13)/C	66.4	200	156	43	4 ± 1	0.65
Co(0.37)/C-473	61.8	112	46	65	—	1.05
Co(0.40)/P(0.20)/C-473	64.9	90	58	32	1.6 ± 0.1	0.5
Co(0.66)/P(0.44)/C	113.5	33	33	0	2.6 ± 0.2	0
Mo(0.41)/C	146.0	246	106	140	—	0.96
Mo(0.41)/P(0.14)/C	143.8	219	72	146	1.2 ± 0.1	1.01
Co(0.26)/Mo(0.37)/C	171.3	373	214	159	—	0.96
Co(0.27)/Mo(0.48)/P(0.22)/C	202.6	282	144	138	1.4 ± 0.2	0.70

<sup>a</sup>Hydrogen sulfide uptake based on the formation of Co<sub>9</sub>S<sub>8</sub> and MoS<sub>2</sub>.<sup>b</sup>Hydrogen consumption above 600 K corrected for the hydrogen consumption in the same temperature region of the phosphorus-free catalyst.<sup>c</sup>Hydrogen sulfide consumption up to 1273 K divided by the theoretical hydrogen sulfide consumption based on the sulfiding of cobalt and molybdenum to Co<sub>9</sub>S<sub>8</sub> and MoS<sub>2</sub>, respectively.

## RESULTS

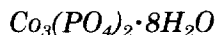
*Model compound*

The sulfiding pattern of  $\text{Co}_3(\text{PO}_4)_2 \cdot 8\text{H}_2\text{O}$  is depicted in Fig. 2. A small amount of hydrogen sulfide was consumed in two regions viz., 400–600 K and 700–850 K. The amount of hydrogen sulfide produced in the region between 850–1000 K was more or less equal to the total amount of hydrogen sulfide consumed in the lower temperature regions. As a consequence, the total hydrogen sulfide uptake was nil at the end of the temperature program, indicating that the catalyst was in a non-sulfidic state. The large hydrogen consumption which was observed between 750 and 1050 K amounted to a hydrogen to phosphorus ratio of  $3.4 \pm 0.1$ . At the end of the temperature program X-ray diffraction (XRD) showed only diffraction lines of  $\text{Co}_2\text{P}$ .

*Catalysts**Carbon support*

The TPS pattern of the pure carbon support (Norit RX3-Extra) is depicted in Fig. 3e. The carbon support was not completely inert towards hydrogen sulfide, although the major part of hydrogen sulfide, consumed at room temperature (2.4 wt.-%), desorbed after start of the temperature program. At the end of the temperature program the total amount of hydrogen sulfide consumed was not negligible; the total hydrogen sulfide uptake amounted to  $0.37 \times 10^{-3}$  mol/g.

*P(1.71)/C*

The TPS patterns of P(1.71)/C is depicted in Fig. 3d. The small hydrogen sulfide production peak, observed directly after the sharp hydrogen sulfide consumption peak at room temperature, is not ascribed to desorption of hy-

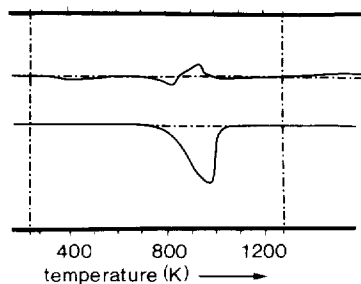

Fig. 2. TPS pattern (hydrogen sulfide signal upper curve, hydrogen signal lower curve) of  $\text{Co}_3(\text{PO}_4)_2 \cdot 8\text{H}_2\text{O}$ .



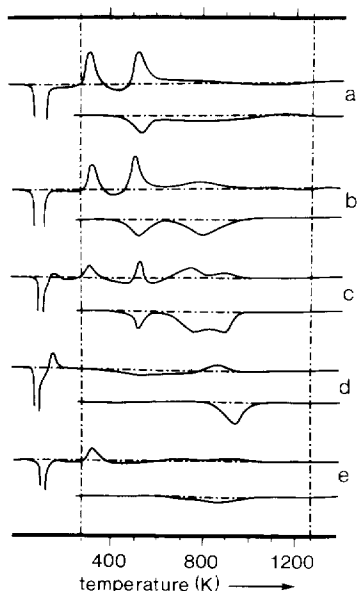

Fig. 3. TPS patterns (hydrogen sulfide signal upper curves, hydrogen signal lower curves) of Co-P/C, P/C and carbon catalysts: (a) Co(0.37)/C-473; (b) Co(0.40)/P(0.20)/C-473; (c) Co(0.66)/P(0.44)/C (prepared from  $\text{Co}_3(\text{PO}_4)_2 \cdot 8\text{H}_2\text{O}$ ); (d) P(1.71)/C; (e) carbon.

hydrogen sulfide but appeared as a result of a multicomponent diffusion effect. This effect also took place during other measurements, however it is obscured by simultaneous hydrogen sulfide consumption. A small hydrogen sulfide consumption between 400–600 K was followed by the production of approximately the same amount of hydrogen sulfide in the temperature region from 800–1000 K. At the end of the temperature program the overall hydrogen sulfide uptake was nil. A large hydrogen consumption coupled to a water production was observed around 920 K, the hydrogen consumption agreed with a hydrogen to phosphorus ratio of  $1.0 \pm 0.1$ .

#### *Co/C, Co/P/C*

The TPS patterns of a Co/C and a Co/P/C catalyst are depicted in Fig. 4a and b. Except for the high-temperature region, the sulfiding patterns are quite similar for both catalysts. A hydrogen sulfide consumption peak was already observed at room temperature. Immediately after rise of the reactor temperature, hydrogen sulfide was produced followed by a large hydrogen sulfide uptake between 350 and 450 K. It is noteworthy that the total hydrogen sulfide uptake below 450 K was much larger than expected on the basis of a complete

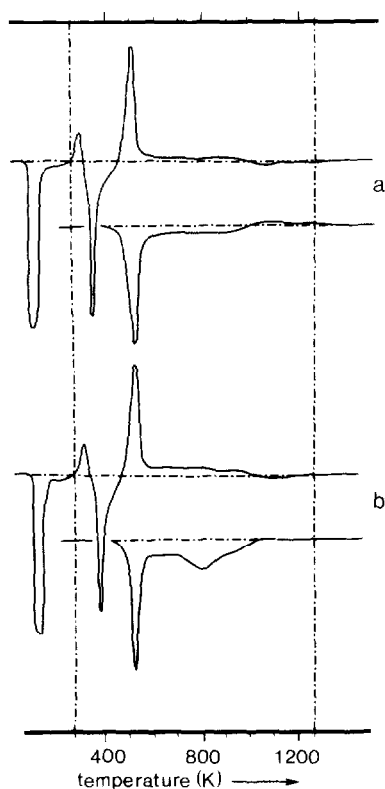

Fig. 4. TPS patterns of Co/P/C (hydrogen sulfide signal upper curves, hydrogen lower curves) catalysts dried at 383 K: (a) Co(0.37)/C; (b) Co(0.41)/P(0.13)/C.

conversion of cobalt into  $\text{Co}_9\text{S}_8$  (in Table 2, 500 K instead of 450 K is chosen as limit for convenience); the sulfur to cobalt ratio was about 3 for these catalysts at 450 K. At about 550 K a large hydrogen sulfide production coupled to a hydrogen consumption was observed. The total amount of hydrogen sulfide consumed amounted to 1.2 mol hydrogen sulfide per mol cobalt for the Co/C catalyst at the end of the temperature program. For the phosphorus-containing catalyst this number was much lower viz., 0.6.

In contrast with the Co/C catalyst, the Co/P/C catalyst showed a large hydrogen consumption around 800 K. Because this hydrogen consumption was exclusively found on phosphorus-containing catalysts, it is ascribed to the reduction of phosphates. The hydrogen to phosphorus ratio amounted to ca.  $4 \pm 1$ .

Due to the fact that the cobalt catalysts were only dried at 383 K, it is obvious that nitrates still can be present. By means of the thermobalance it is possible to conclude whether or not nitrates are still present on the carbon-supported cobalt catalysts. The temperature dependent weight changes of Co(4.1)/C,

$\text{Co}(\text{NO}_3)_2 \cdot 6\text{H}_2\text{O}$  and the carbon support have been measured. The differential thermogravimetry (DTG) signal of the carbon support showed only one peak at ca. 320 K, which could be ascribed to the removal of physisorbed water. Both the DTG patterns of  $\text{Co}(4.1)/\text{C}$  and  $\text{Co}(\text{NO}_3)_2 \cdot 6\text{H}_2\text{O}$  showed two peak maxima at ca. 370 and 470 K. The total weight loss in the second peak agreed with the maximum amount of nitrates present in both samples. The peak at ca. 370 K is ascribed to the removal of crystal water and crystal and physisorbed water in the case of  $\text{Co}(\text{NO}_3)_2 \cdot 6\text{H}_2\text{O}$  and  $\text{Co}(4.1)/\text{C}$ , respectively. The influence of these nitrates on the TPS patterns, can be seen nicely by comparing the  $\text{Co}/\text{C}$  and  $\text{Co}/\text{P}/\text{C}$  catalysts dried at 383 K (Fig. 4) with those dried at 473 K (Fig. 3a and b). The catalysts dried at 383 K showed much larger hydrogen sulfide consumption and production peaks in the low temperature region than those dried at 473 K. The sulfur to cobalt ratio for the  $\text{Co}/\text{P}/\text{C}$  catalyst, determined at 1270 K was much less than the amount expected on the basis of sulfiding to  $\text{Co}_9\text{S}_8$  or  $\text{CoS}$ . Above 800 K a hydrogen consumption was found, which agreed with a hydrogen to phosphorus ratio of 1.6; simultaneously with this consumption a small hydrogen sulfide production was observed.

The sulfiding pattern of the  $\text{Co}-\text{P}/\text{C}$  catalyst, prepared by adding  $\text{Co}_3(\text{PO}_4)_2$  to the carbon support is shown in Fig. 3c. The amount of hydrogen sulfide consumed below 380 K was less for this catalyst than for the catalyst prepared from cobalt nitrates and  $\text{H}_3\text{PO}_4$ . Due to the hydrogen sulfide production in the temperature region from 600–900 K, the overall hydrogen sulfide consumption became nil. These hydrogen sulfide production peaks appeared simultaneously with hydrogen consumption peaks. The hydrogen to phosphorus ratio, calculated from the hydrogen consumption in the temperature region from 600–900 K, amounted to ca. 2.6. The second hydrogen consumption peak at 900 K appeared at about the same temperature as the hydrogen consumption in the TPS pattern of the  $\text{P}/\text{C}$  catalyst.

### *Mo/C, Mo/P/C*

The sulfiding patterns are depicted in Fig. 5. The hydrogen sulfide consumption curves are nearly identical for both catalysts. Hydrogen sulfide consumption peaks were observed at room temperature and between 350 and 500 K. These two consumption peaks were divided by a hydrogen sulfide production peak at ca. 330 K. The hydrogen sulfide to molybdenum ratio was ca. 3.0–3.4 at 500 K. At about 500 K a sharp hydrogen sulfide production was observed, coupled to a hydrogen consumption peak. For both catalysts the sulfur to molybdenum ratio decreased to ca. 2 at the end of the temperature program. Phosphorus had only a small influence on the sulfiding patterns and the sulfur to molybdenum ratios. For the phosphorus-containing catalyst, a hydrogen consumption is found at 750 K which agreed with a hydrogen to phosphorus ratio of ca. 1.2.

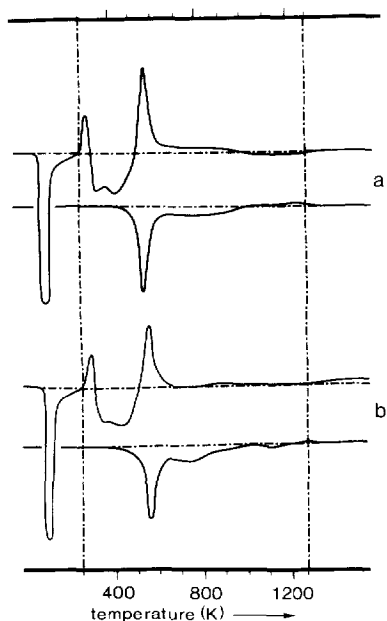

Fig. 5. TPS patterns of Mo/P/C (hydrogen sulfide signals upper curves, hydrogen lower curves) catalysts: (a) Mo(0.41)/C; (b) Mo(0.41)/P(0.14)C.

#### *Co/Mo/C, Co/Mo/P/C*

The sulfiding patterns of these catalysts are shown in Fig. 6. The sulfiding patterns of both catalysts are quite similar except for two parts viz., the TPS patterns of the phosphorus-containing catalysts showed an additional hydrogen consumption between 600 and 900 K and a hydrogen sulfide production between 800 and 1000 K. Since this hydrogen consumption is absent in the TPS pattern of the Co/Mo/C catalysts, it can be ascribed to the reduction of phosphates. The hydrogen consumption between 600 and 900 K resulted in a hydrogen to phosphorus ratio of ca. 1.4. From Table 2, it is obvious that phosphorus influenced the extent of sulfiding. The amount of hydrogen sulfide consumed below 500 K was significantly less in the case of the phosphorus-containing catalyst. For the Co/Mo/C catalyst the integrated S-uptake at 1270 K is close to the formation of  $\text{Co}_9\text{S}_8$  and  $\text{MoS}_2$ . For the Co/Mo/P/C catalyst the S-uptake is considerably lower.

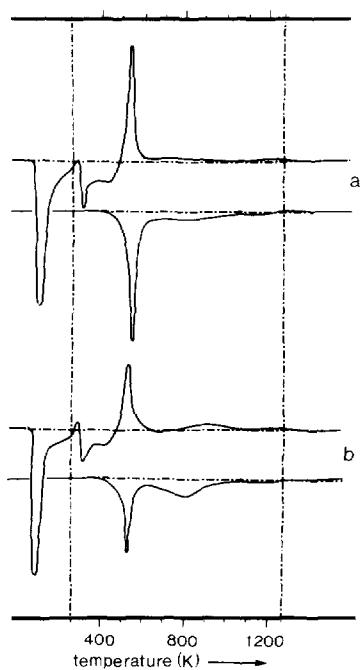
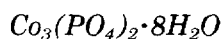

Fig. 6. TPS patterns of Co/Mo/P/C (hydrogen sulfide signal upper curves, hydrogen signal lower curves) catalysts: (a) Co(0.26)/Mo(0.37)/C; (b) Co(0.27)/Mo(0.48)/P(0.22)/C.

## DISCUSSION

### *Model compound*



The main conclusion that can be drawn from the sulfiding pattern in Fig. 2, is that  $\text{Co}_3(\text{PO}_4)_2 \cdot 8\text{H}_2\text{O}$  is quite stable towards sulfiding, only minor sulfiding is observed below 850 K. It is not clear whether this hydrogen sulfide uptake has to be ascribed to the formation of cobalt sulfides or phosphorus oxysulfides in the outer parts of the particles. These partially sulfided species will be indicated as  $\text{Co}_3(\text{PO}_{4-x}\text{S}_x)_2$ . Despite some initial sulfiding, the catalyst was in a non-sulfidic state at the end of the temperature program. XRD confirmed this observation, only diffraction lines attributable to  $\text{Co}_2\text{P}$  were observed and no indication for the presence of  $\text{Co}_9\text{S}_8$  or  $\text{Co}_4\text{S}_3$  was found. Therefore, we assume that the hypothetical  $\text{Co}_3(\text{PO}_{4-x}\text{S}_x)_2$  compound reacted at ca. 900 K to  $\text{Co}_2\text{P}/\text{CoP}$ , hydrogen sulfide and water according to reaction (1).

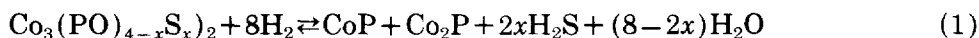

It is interesting that after TPR of  $\text{Co}_3(\text{PO}_4)_2$  both CoP and  $\text{Co}_2\text{P}$  have been

formed [8]. Evidently, the reduction of the cobalt ions in the temperature region from 800–1050 K can also take place by direct reduction of  $\text{Co}_3(\text{PO}_4)_2$  according to reaction (2) rather than first reacting to a partially sulfided intermediate.

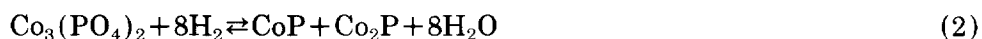

Since only  $\text{Co}_2\text{P}$  was detected with XRD after the sulfiding up to 1270 K, we might suggest that a transformation of  $\text{CoP}$  to  $\text{Co}_2\text{P}$  has taken place. However, since decomposition of  $\text{CoP}$  to  $\text{Co}_2\text{P}$  only depends on the pressure of  $\text{P}_4$  and hydrogen and not on the presence of hydrogen sulfide we expect that cobalt was both present as  $\text{CoP}$  and  $\text{Co}_2\text{P}$  after sulfiding at 1270 K. Apparently, the  $\text{CoP}$  islands were too small or relatively too amorphous to be detected with XRD. It might also be suggested that  $\text{CoP}_3$  is formed, however  $\text{CoP}_3$  can be ruled out as a potential product because it has a partial pressure of  $\text{P}_4$  vapour  $\geq 1 \times 10^{-3}$  bar above 1100 K [20].

The hydrogen to phosphorus ratio of ca. 3.4 is slightly less than expected on the basis of reactions (1), (2) (hydrogen/phosphorus = 4). The difference indicates that not all  $\text{P}_2\text{O}_5$  is reduced to elemental phosphorus or  $\text{PH}_3$ ; most likely a part of the phosphorus has been sublimed as  $\text{P}_2\text{O}_5$  vapour during the temperature program.

At first sight, the formation of non-sulfidic compounds from sulfidic and oxidic species in a hydrogen sulfide/hydrogen environment is surprising. To understand that non-sulfidic compounds can indeed be formed under these conditions it is useful to look at the Gibbs free energy for the reactions involved. From the Gibbs free energy, the partial pressure of the reaction products at equilibrium can be calculated. On the basis of these partial pressures the maximum amount of products which can be removed per unit of time in our flow system can be calculated and, as a consequence, the time it takes for a reaction to go to completion can be estimated. In Fig. 7, a crosshatched area separates the zones where two typical reactions viz.,  $\text{CoS}_{0.89}$  to  $\text{CoP}$  and  $\text{MoS}_2$  to  $\text{MoP}$  can and cannot proceed on the time scale of our TPS experiments ( $5.4 \cdot 10^3$  s). Because of lack of detailed thermodynamic data the lines, representing the water partial pressure at equilibrium, are calculated from temperature independent enthalpy and entropy values. Despite the fact that the uncertainty of the position of these lines increases with the temperature, rough estimations can be made of the temperature region where the reactions are thermodynamically permitted. Fig. 7 shows that the reaction of  $\text{CoS}_{0.89}$  to  $\text{CoP}$  is thermodynamically permitted in the whole temperature region. Clearly, in the whole temperature region  $\text{CoP}$  is stable in the hydrogen sulfide containing atmosphere, at least when eqn. (1) defined in Fig. 7 describes the possible chemical transformation. To check if indeed  $\text{CoP}$  is stable in the high-temperature region analogous thermodynamic calculations were executed for other possible reactions such as:  $\text{CoP} + 0.89\text{H}_2\text{S} \rightleftharpoons \text{CoS}_{0.89} + 0.89\text{H}_2 + 0.25\text{P}_4$ . These

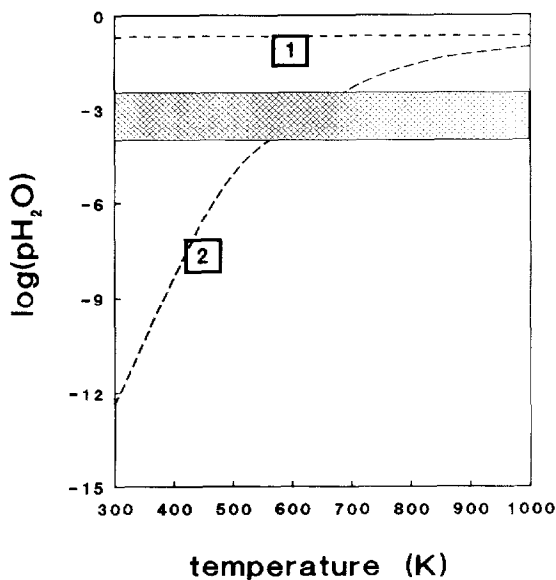

Fig. 7. The water partial pressure at thermodynamic equilibrium is shown for two reactions: (1)  $\text{CoS}_{0.89} + 0.5\text{P}_2\text{O}_5 + 3.39\text{H}_2 \rightleftharpoons \text{CoP} + 0.89\text{H}_2\text{S} + 2.5\text{H}_2\text{O}$ ; (2)  $\text{MoS}_2 + 0.5\text{P}_2\text{O}_5 + 4.5\text{H}_2 \rightleftharpoons \text{MoP} + 2\text{H}_2\text{S} + \text{H}_2\text{O}$ . The crosshatched area indicates lower limit of the water partial pressure at which these reactions can take place with a measurable rate.

calculations showed that the reaction of CoP to  $\text{CoS}_{0.89}$  (and  $\text{P}_4$  or  $\text{PH}_3$ ) can only proceed on a time scale far exceeding that of the TPS experiments.

### Catalysts

#### Carbon support

The major part of the hydrogen sulfide consumed at room temperature was physisorbed and therefore desorbed after rise of the reactor temperature. The total amount of hydrogen sulfide consumed at the end of the temperature program agreed very well with the total amount of hydrogen sulfide produced during a TPR experiment of a carbon support which had been sulfided at 673 K [21]. The fact that both values are almost identical, indicates that no elemental sulfur is formed during the TPS experiment. It is concluded that all hydrogen sulfide consumed was used to sulfide oxygen-containing functional groups whereas the reaction between hydrogen sulfide and the functional groups to elemental sulfur and water (Claus reaction), which might have been expected, was of minor importance. The hydrogen sulfide consumed during the temperature program is used for sulfiding of functional groups which most likely results in the formation of sulfydryl and heterocyclic groups. Part of these sul-

fydryl groups recombine during the temperature program to hydrogen sulfide but the major part of the sulfur most likely ends up as heterocyclic compounds or as isolated S–H groups. Since it is not fully clear whether the functional groups were still present on the catalysts which contain metal oxides, no correction has been made for the hydrogen sulfide consumption of the carbon-supported catalysts.

### *P(1.71)/C*

The hydrogen sulfide production around 870 K can be ascribed to the reduction of small amounts of phosphorusoxysulfides, formed in a broad temperature region at lower temperatures. The low sulfur to phosphorus ratio ( $\pm 0.15$ ) indicates that only a small part of the oxygen atoms in the  $P_2O_5$  species is substituted by sulfur.  $P_{red}$ ,  $P_{white}$ ,  $P_{black}$ ,  $P_4$ ,  $P_2O_3$  and  $PH_3$  are the reaction products which can be formed upon reduction of phosphorusoxysulfides and phosphoruspentoxide structures. In previous work it is explained that gaseous  $P_4$  is the most likely reaction product after reduction of alumina-supported phosphates [8]. In comparison with the reduction of alumina-supported phosphates, reduction of carbon-supported phosphates took place at lower temperatures. Notwithstanding the increased stability of  $PH_3$  towards lower temperatures, thermodynamic calculations reveal that at equilibrium of reaction (3),  $P_4$  is still the dominating gaseous constituent.



However, at the end of the temperature program, the hydrogen to phosphorus ratio is less than expected on the basis of complete reduction of the phosphates to  $P_4$ . This incomplete reduction can be explained by assuming partial reduction of  $P_2O_5$  to  $P_4$  whereas the remaining part sublimates as  $P_2O_5$  during the temperature program. However the low hydrogen to phosphorus ratio of ca. 1 might likewise implicate that  $P_2O_5$  is reduced to  $P_2O_3$  which directly sublimates due to its lower volatility than  $P_2O_5$  (boiling point of  $P_2O_3$  is 448 K whereas  $P_2O_5$  starts to sublime at 573 K [22]).

### *Co/C, Co/P/C*

Table 2 shows that the amount of hydrogen sulfide consumed up to 500 K is much larger than expected on the basis of sulfiding of all cobalt to  $Co_9S_8$ . This large value is most likely caused by the reaction of cobalt nitrates, which were not decomposed upon drying at 383 K, and hydrogen sulfide. The gravimetric measurements provided the evidence that the cobalt nitrates were not decomposed upon drying at 383 K. That this reaction is playing an important role can be noticed by comparing the sulfiding patterns of the Co/C catalysts dried at 383 K and 473 K. The large amount of hydrogen sulfide consumption is caused by the reaction between hydrogen sulfide and nitric oxide, nitrous oxide



and oxygen to elemental sulfur according to reactions (4a), (4b) and (4c) analogous to the Claus reactions:



Probably these reactions are catalysed by carbon, as active carbon is known to be an active catalyst for the oxidation of hydrogen sulfide [23]. The elemental sulfur produced reacted at about 530 K with hydrogen to hydrogen sulfide. The sulfur to cobalt ratio determined at the end of temperature program is rather inaccurate for the Co/C and Co/P/C catalysts, which were dried at 383 K (Fig. 4) because the overall hydrogen sulfide consumption has been calculated by subtraction of the large hydrogen sulfide consumption and production peaks. Therefore, the influence of phosphorus on the sulfur content in these catalysts can be acquired more accurately from the sulfiding of Co-P/C prepared from  $\text{Co}_3(\text{PO}_4)_2$  and the Co/C and Co/P/C samples dried at 473 K.

The quantitative data in Table 2 nicely show the influence of phosphorus on the sulfiding rate and the sulfur content of the Co(0.66)P(0.44)/C (prepared from  $\text{Co}_3(\text{PO}_4)_2 \cdot 8\text{H}_2\text{O}$ ) and the Co(0.40)/P(0.20)/C-473 catalyst. The lower sulfiding rate of cobalt species in Co-P/C catalysts, especially the Co(0.66)P(0.44)/C catalyst, indicates that other cobalt species are present than on the phosphorus-free catalysts. This strong decrease of the sulfiding rate can be explained by the formation of a  $\text{Co}^{2+}$ -phosphate phase. The formation of this phase is very likely since the phosphate anions can act as anchoring sites for  $\text{Co}^{2+}$  ions [9]. In the literature little is known about the interaction between supported phosphates and transition metals. Indications for an interaction between phosphates and iron ions have been found using Mössbauer spectroscopy. Mössbauer spectroscopy revealed the formation of an "Fe- $\text{PO}_4$ " like phase [10]. Because the Mössbauer parameters did not match those reported for typical iron phosphate compounds this phase could not be identified as a well-defined compound. In analogy with these results we assume that rather ill-defined cobaltphosphate compounds, of which the geometric structure and stoichiometry can be subject to discussion, are present on the carbon support. Because sulfiding of this catalyst takes place over a broad temperature region, it is most likely that the cobalt ions are surrounded by a different number of tetrahedral phosphate neighbours. The sulfiding most likely decreases with increasing number of phosphate neighbours.

The small amount of  $\text{Co}_9\text{S}_8$  present at 600 K reacts with  $\text{P}_2\text{O}_5$  to  $\text{CoP}_3$ ,  $\text{CoP}$  or  $\text{Co}_2\text{P}$ , water and hydrogen sulfide between 600–800 K. The reduction of partially sulfided " $\text{Co-PO}_{4-x}\text{S}_x$ " species takes place in this same temperature region. In case  $\text{CoP}_3$  is formed this will decompose around 900 K as described

elsewhere [8]. The reactions which took place on the carbon-supported catalysts are similar to those observed for the model compound,  $\text{Co}_3(\text{PO}_4)_2 \cdot 8\text{H}_2\text{O}$ . In comparison with the model compound, these reactions are observed at lower temperatures on the carbon-supported catalysts. This difference in reaction temperature is not surprising and is mainly due to a difference in particle size of cobalt phosphate on the support and the model compound.

The hydrogen to phosphorus ratio shows that nearly all  $\text{P}_2\text{O}_5$  has reacted with cobalt to cobalt phosphides or is reduced to elemental phosphorus (P or  $\text{P}_4$ ), except for the Co(0.40)/P(0.20)/C-473 catalyst. In case of this catalyst a part of the (weakly-bound)  $\text{P}_2\text{O}_5$  is most likely sublimed during the drying step.

### *Mo/C, Mo/P/C*

The relatively weak interaction of the molybdenum species with the carbon support resulted in complete sulfiding to  $\text{MoS}_2$  of all the molybdenum oxide species already below 500 K. The catalysts are sulfided according to the oxygen-sulfur exchange mechanism proposed by Arnoldy et al. [19].  $\text{Mo}^{6+}$  is reduced to  $\text{Mo}^{4+}$  by rupture of a Mo-S bond in  $\text{MoS}_3$  or  $\text{MoO}_x\text{S}_y$  species; the elemental sulfur formed in this way, reacts with hydrogen to hydrogen sulfide at 560 K. The large sulfur to molybdenum ratios ( $\pm 3$ ) below 500 K support this mechanism (Table 2).

Phosphorus has no influence on the sulfiding rate and sulfur content of the Mo/C catalyst within the limits of accuracy of our measurements. These results indicate that even if molybdophosphate compounds were initially present, molybdenum was completely sulfided to  $\text{MoS}_2$ . Complete sulfiding of Mo/P/C catalysts was also observed by Bouwens and co-workers [15,16].

In contrast with  $\text{Co}_9\text{S}_8$ , which partially reacted to CoP and/or  $\text{Co}_2\text{P}$ ,  $\text{MoS}_2$  has not reacted to  $\text{MoP}_x$  ( $x = 1/3, 1$  or  $2$ ). A possible explanation for this phenomenon can be deduced from thermodynamic data [24,25]. Thermodynamic calculations with  $\Delta H_f^0$  and  $S_{298}^0$  lead to a rough estimation of the temperature region where a reaction can possibly proceed. The  $H_f^0$  of MoP is estimated by comparing  $H_f^0$  values and decomposition temperatures of comparable phosphides [24,25]. It can be observed from Fig. 7 that the reaction  $\text{CoS}_{0.89} + 0.5\text{P}_2\text{O}_5 + 3.39\text{H}_2 \rightleftharpoons \text{CoP} + 0.89\text{H}_2\text{S} + 2.5\text{H}_2\text{O}$  could proceed in the whole temperature region studied. However, due to the greater stability of  $\text{MoS}_2$  compared to  $\text{CoS}_{0.89}$  and the relative instability of MoP compared to CoP, the reaction of  $\text{MoS}_2 + 0.5\text{P}_2\text{O}_5 + 4.5\text{H}_2 \rightleftharpoons \text{MoP} + 2.5\text{H}_2\text{O} + 2\text{H}_2\text{S}$  can only take place above ca. 700 K. Moreover, it has to be expected that around this temperature nearly all the  $\text{P}_2\text{O}_5$  will have been removed via sublimation or reduction to  $\text{P}_4$ . Therefore no  $\text{P}_2\text{O}_5$  is left for the reaction with  $\text{MoS}_2$  above 700 K where this reaction, based on thermodynamic grounds, can go to completion on the time scale of our TPS experiments.

*Co-Mo/C, Co-Mo-P/C*

Analogous to the carbon-supported cobalt and molybdenum catalysts, Co-Mo/C and Co-Mo-P/C catalysts are completely sulfided below 500 K. Since the entire process takes place within a relatively short temperature range, sulfiding of different species cannot be discerned. The sulfiding pattern of Co-Mo-P/C catalyst can be described by combining the patterns of Co-P/C and Mo-P/C catalysts. Taking into account the relatively low sulfur content of the Co-Mo-P/C catalyst at the end of the temperature program, it can be concluded that part of the cobalt species reacted to cobaltphosphides, whereas molybdenum was still present as  $\text{MoS}_2$  at the end of the temperature program.

*Implications for the HDS activity*

The thiophene HDS activity of carbon-supported catalysts is strongly decreased by addition of phosphorus. The poisoning effect of carbon-supported catalysts as a result of addition of phosphates has not only been found for cobalt, molybdenum and Co-Mo catalysts but also for nearly all carbon-supported transition metals [18]; the only exception were carbon-supported nickel catalysts which showed an increase in the HDS activity. Several possibilities have been put forward to explain this influence of phosphorus: (I) decrease of the metal sulfide dispersion [9]; (II) formation of a HDS inactive metal-phosphate complex [9,10]; (III) poisoning of the active sites by  $\text{PH}_3$  [17,18]; (IV) formation of metal phosphides [18]; (V) formation of metal phosphosulfides [18].

XPS and Mössbauer measurements revealed that the dispersion of the metal oxides and metal sulfides (iron, cobalt, molybdenum) studied increased or remained constant upon addition of phosphorus [9,10,14]. Hence, the first explanation can be rejected. Despite the fact that reduction of the thiophene HDS activity of carbon-supported catalysts by phosphorus is a commonly observed effect, no general explanation has been given. According to Bouwens et al. [16] Mo-P/C catalysts are poisoned due to the adsorption of  $\text{PH}_3$  on the anion vacancies whereas the cobalt- and iron-containing catalysts were poisoned due to the presence of non-sulfidible "Co(II) phosphate" and "Fe(II) phosphate". Recently, Eijsbouts et al. [17,18] have proposed the formation of phosphides and phosphosulfides as a possible explanation for this poisoning effect.

This TPS study of carbon-supported catalysts resulted in detailed information on the structure of these catalysts after sulfiding. Despite the fact that the experiments have been performed in a temperature-programmed mode, the structure of the catalysts after sulfiding at 670 K can be deduced from the TPS measurements.

"Co- $\text{PO}_4$ " species present on a carbon support not be sulfided up to 670 K under our TPS conditions. Instead of sulfiding to  $\text{Co}_9\text{S}_8$ , they started to reduce to  $\text{CoP}_3$ ,  $\text{CoP}$  or  $\text{Co}_2\text{P}$  around 670 K. Even  $\text{Co}_9\text{S}_8$  which was formed in the low-

temperature region reacted with  $P_2O_5$  and hydrogen to  $CoP_x$  and hydrogen sulfide. Consequently, Co/C and Co-Mo/C catalysts can be poisoned due to the formation of cobalt phosphide species, which are apparently inactive in HDS. Bouwens et al. [9] obtained, via XPS analysis of Co/C and Co-Mo/C catalysts indications for the presence of cobalt phosphate species after sulfiding at 673 K. As can be observed in the TPS patterns of Co-P/C, the rate at which the "Co- $PO_4$ " species react to  $CoP_x$  ( $x=0.5, 1$  and  $3$ ) is relatively low at 670 K. From TPS experiments in which an isothermal sulfiding stage, at 673 K, was introduced, it was observed that the amount of phosphorus present as phosphate slowly decreased upon increasing reaction time. Even after  $28.8 \times 10^3$  s still a small part of the phosphorus was present as phosphates. Hence, at the start of the HDS reaction, the main reason for the detrimental effect of phosphorus might very well be the presence of inactive "cobalt phosphate" whereas at prolonged reaction time poisoning will entirely take place due to the formation of inactive cobalt phosphides.

The independence of the sulfur to molybdenum ratio on the presence or absence of phosphorus, indicates that poisoning of the Mo-P/C catalysts does not occur by the same mechanism as the poisoning of the Co/C and Co-Mo/C catalysts. TPS of the Mo-P/C sample indicates that  $P_2O_5$  is reduced between 600–800 K, producing elemental phosphorus (P or  $P_4$ ). On the basis of the amount of hydrogen consumed between 600 and 1100 K, the amount of elemental phosphorus formed can be deduced, resulting in a phosphorus to molybdenum ratio of ca. 0.14. From the fact that the activity of this catalyst is reduced to ca. 15% of the activity of the phosphorus-free catalyst [16] we conclude that the catalysts are poisoned due to the adsorption of phosphorus on the anion vacancies on the edges of the  $MoS_2$  slabs, which automatically results in effective poisoning of the thiophene HDS activity. As the phosphorus-containing catalyst is not recovering its activity after prolonged reaction times, it is clear that phosphorus is strongly chemisorbed on the active sites.

This present TPS study showed the complexity of the poisoning of the carbon-supported catalysts. The nature of the poisoning depends on various parameters e.g., reaction temperature, hydrogen pressure, hydrogen sulfide pressure. In addition to these parameters the poisoning of the carbon-supported transition metals depends on the metals used viz., the thermodynamic stability of metal phosphates, metal sulfides and metal phosphides. This is nicely demonstrated by comparison of the thermodynamic data of the relevant compounds of cobalt and molybdenum.

## CONCLUSIONS

(i)  $Co_3(PO_4)_2 \cdot 8H_2O$  is not sulfided below 800 K under our TPS conditions but is reduced to  $Co_2P$  and  $CoP$  in a hydrogen sulfide/hydrogen mixture between 800–1100 K.

(ii) "Co-PO<sub>4</sub>" species are present on Co-P/C catalysts. Analogous to Co<sub>3</sub>(PO<sub>4</sub>)<sub>2</sub>·8H<sub>2</sub>O these species are slightly sulfidable below 673 K but reduced to cobaltphosphides between 650 and 800 K.

(iii) On Co/C catalysts, which are dried at 383 K, large amounts of elemental sulfur are formed in the low-temperature range, due to the reaction of hydrogen sulfide with the un-decomposed nitrates.

(iv) Co<sub>9</sub>S<sub>8</sub> reacts with P<sub>2</sub>O<sub>5</sub> and hydrogen to CoP<sub>x</sub> and hydrogen sulfide between 650–800 K. These cobalt phosphides are not re-sulfided up to 1270 K.

(v) At the start of the HDS reaction Co-P/C and Co-Mo-P/C catalysts are poisoned due to the presence of cobalt phosphates whereas after prolonged reaction times the catalysts are exclusively poisoned by the formation of cobalt phosphides.

(vi) The sulfiding rate and sulfur content of the Mo/C catalyst is not influenced by the presence of phosphates.

(vii) Poisoning of the Mo-P/C catalysts most likely occurs by chemisorption of elemental phosphorus and/or P<sub>4</sub> on the anion vacancies present on the MoS<sub>2</sub> edges.

(viii) The nature of the poisoning effect depends mainly on the relative thermodynamic stability of the metal phosphates, metal sulfides and metal phosphides.

#### ACKNOWLEDGEMENTS

Thanks are due to Dr. B. Koch and W. Molleman (Department of X-ray Spectrometry and Diffractometry, University of Amsterdam).

#### REFERENCES

- 1 G.A. Michelson, U.S. Patents 3 749 663, 3 755 196, 3 755 196, 3 755 150, 3 755 148 and 3 749 664 (1973).
- 2 P. Atanasova, T. Halachev, J. Uchytíl and M. Kraus, *Appl. Catal.*, 38 (1988) 235.
- 3 D. Chadwick, D.W. Aitchison, R. Badilla-Ohlbaum and L. Josefsson, in G. Poncelet, P. Grange and P.A. Jacobs (Editors), *Preparation of Catalysts III (Studies in Surface Science and Catalysis, Vol. 16)*, Elsevier, Amsterdam, 1982, p. 323.
- 4 W.S. Millman, U.S. Patent 4 392 985 (1983).
- 5 M.M. Ramirez de Agudelo and A. Morales, in M.J. Phillips and M. Ternan (Editors), *Proc. 9th Int. Congr. on Catalysis, Vol. I*, The Chemical Institute of Canada, Ottawa, 1988, p. 42.
- 6 S. Eijssbouts, L. van Gruijthuijsen, J. Volmer, V.H.J. de Beer and R. Prins, in M.L. Occelli and R.G. Athony (Editors), *Advances in Hydrotreating Catalysts*, Elsevier, Amsterdam, 1989, p. 79.
- 7 R.E. Tischer, N.K. Narain, G.J. Stiegel and D.L. Cillo, *Ind. Eng. Chem. Res.*, 26 (1987) 422.
- 8 P.J. Mangnus, J.A.R. van Veen, S. Eijssbouts, V.H.J. de Beer and J.A. Moulijn, *Appl. Catal.*, 61 (1990) 99.
- 9 S.M.A.M. Bouwens, A.M. van der Kraan, V.H.J. de Beer and R. Prins, *J. Catal.*, submitted for publication.

- 10 W.L.T.M. Ramselaar, S.M.A.M. Bouwens, V.H.J. de Beer and A.M. van der Kraan, *Hyperfine Interact.*, 46 (1989) 599.
- 11 C.W. Fitz and H.F. Rase, *Ind. Eng. Chem. Prod. Res. Dev.*, 22 (1983) 40.
- 12 P.D. Hopkins and B.L. Meyers, *Ind. Eng. Chem. Prod. Res. Dev.*, 22 (1983) 421.
- 13 H. Topsøe, B.S. Clausen, N-Y. Topsøe and P. Zeuthen, in D.L. Trimm, S. Akashah, M. Absi-Halabi and A. Bishara (Editors), *Catalysts in Petroleum Refining*, Elsevier, Amsterdam, 1990, p. 77.
- 14 J.P.R. Vissers, T.J. Lensing, V.H.J. de Beer and R. Prins, in *Proc. of the 6th Biennial Conference on Carbon*, San Diego, CA, 1983, p. 607.
- 15 J.P.R. Vissers, S.M.A.M. Bouwens, V.H.J. de Beer and R. Prins, *ACS Div. Pet. Chem.*, 31 (1986) 227.
- 16 S.M.A.M. Bouwens, J.P.R. Vissers, V.H.J. de Beer and R. Prins, *J. Catal.*, 112 (1988) 401.
- 17 S. Eijsbouts, J.N.M. van Gestel, L.M.P. van Gruijthuijsen, J. Volmer, R. Prins and V.H.J. de Beer, *Extended Abstracts 19th Biennial Conference on Carbon*, Penn State University, PA, 1989, p. 46.
- 18 S. Eijsbouts, PhD. Thesis, Technical University of Eindhoven, Eindhoven, 1989.
- 19 P. Arnoldy, J.A.M. van den Heijkant, G.D. de Bok and J.A. Moulijn, *J. Catal.*, 92 (1985) 35.
- 20 W. Biltz and M. Heimbrecht, *Z. Anorg. Allg. Chem.*, 241 (1939) 349.
- 21 P.J. Mangnus, A. Bos and J.A. Moulijn, to be published.
- 22 R.C. Weast and M.J. Astle (Editors), *Handbook of Chemistry and Physics*, CRC press, Boca Raton, FL, 60th ed., 1979.
- 23 M. Steijns and P. Mars, *J. Catal.*, 35 (1974) 11.
- 24 O. Kubaschewski, E.L.L. Evans and C.B. Alcock, *Metallurgical Thermochemistry*, Pergamon Press, London, 4th ed., 1967.
- 25 J.R.C. Van Wazer, *Phosphorus and its Compounds*, Vol. I, Interscience Publishers, New York, 1958.