

Dilatometer for use in tensile tests

Citation for published version (APA):

Coumans, W. J., & Heikens, D. (1980). Dilatometer for use in tensile tests. *Polymer*, 21(8), 957-961.
[https://doi.org/10.1016/0032-3861\(80\)90254-2](https://doi.org/10.1016/0032-3861(80)90254-2)

DOI:

[10.1016/0032-3861\(80\)90254-2](https://doi.org/10.1016/0032-3861(80)90254-2)

Document status and date:

Published: 01/01/1980

Document Version:

Publisher's PDF, also known as Version of Record (includes final page, issue and volume numbers)

Please check the document version of this publication:

- A submitted manuscript is the version of the article upon submission and before peer-review. There can be important differences between the submitted version and the official published version of record. People interested in the research are advised to contact the author for the final version of the publication, or visit the DOI to the publisher's website.
- The final author version and the galley proof are versions of the publication after peer review.
- The final published version features the final layout of the paper including the volume, issue and page numbers.

[Link to publication](#)

General rights

Copyright and moral rights for the publications made accessible in the public portal are retained by the authors and/or other copyright owners and it is a condition of accessing publications that users recognise and abide by the legal requirements associated with these rights.

- Users may download and print one copy of any publication from the public portal for the purpose of private study or research.
- You may not further distribute the material or use it for any profit-making activity or commercial gain
- You may freely distribute the URL identifying the publication in the public portal.

If the publication is distributed under the terms of Article 25fa of the Dutch Copyright Act, indicated by the "Taverne" license above, please follow below link for the End User Agreement:

www.tue.nl/taverne

Take down policy

If you believe that this document breaches copyright please contact us at:

openaccess@tue.nl

providing details and we will investigate your claim.

Dilatometer for use in tensile tests

W. Jan Coumans and Derk Heikens

Laboratory of Polymer Technology, Eindhoven University of Technology, Eindhoven, The Netherlands
(Received 19 July 1979; revised 5 October 1979)

An accurate dilatometer system is presented, which permits a simultaneous and automatic recording of sample volume change during a tensile test on a commercial tensile tester. Liquid displacements in the dilatometer capillary, which correspond to volume changes of the sample, are detected by means of a conductivity meter; tensile load is obtained from the testing machine itself; sample elongation is measured by means of an inductive displacement meter. Some experimental curves are reproduced and briefly discussed.

INTRODUCTION

During research on blends of polystyrene (PS), low density polyethylene (LDPE) and block copolymers PS-*b*-LDPE, tensile tests were analysed. To explain the observed yielding behaviour two deformation mechanisms, crazing and shearing, must be considered. Bucknall¹ showed that measurement of the volume change of a specimen during extension is a good aid to distinguish crazing from shearing. For application of this principle in tensile tests it was decided to build a dilatometer. The first results of the dilatometric investigation of polymer blends are already published². In this paper, the dilatometer apparatus will be described.

Theory

During a tensile test the cross-sectional area of a specimen diminishes, whereas its length increases. The parameter relating these changes in dimensions is the Poisson ratio (ν) defined as:

$$\frac{dW}{W} = -\nu \frac{dL}{L} \quad (1)$$

where dW/W is the lateral strain and dL/L is the axial strain. For isotropic materials a simple equation for the volume strain dV/V can be derived:

$$\frac{dV}{V} = (1 - 2\nu) \frac{dL}{L}$$

which becomes for the initial elongation:

$$\frac{\Delta V}{V_0} = (1 - 2\nu) \frac{\Delta L}{L_0} \quad (2)$$

For most materials the Poisson ratio at small strains (elastic behaviour) lies between 0.2 and 0.5. Absence of volume change corresponds with a Poisson ratio of 0.5 (e.g. rubber). From measurements of the initial Poisson ratio *versus* concentration, information can be gained about morphology and about the state of adhesion between the phases in polymer blends². At higher strains, beyond the yield point

of toughened plastics, two deformation mechanisms can be distinguished: crazing and shearing. These mechanisms do not occur in isolation – they are always preceded or accompanied by elastic deformation. As already described in detail by Bucknall¹ crazing includes void formation and does not contribute to lateral strain ($\nu_{cr} = 0$), so a graph of $\Delta V/V_0$ *versus* $\Delta L/L_0$ will have unit slope. Shearing, on the contrary, includes no loss of intermolecular cohesion and its contribution to the volume change is zero ($\nu_{sh} = 0.5$), so a graph of $\Delta V/V_0$ *versus* $\Delta L/L_0$ will have zero slope. It will be clear that, from intermediate slope values the contribution of crazing and shearing to the yielding deformation can be derived quantitatively.

DILATOMETER SYSTEM

To determine the volume change of a sample during a tensile test two methods can be distinguished.

The volume change is calculated from axial and lateral strains. Darlington and Saunders³ developed extensometers, being very suitable if the rate of deformation is low. Cessna⁴ used high speed film to follow index marks on the specimens in high rate experiments.

The volume change can be measured also directly in a liquid displacement dilatometer. An increase of the sample volume results in a rise of the liquid level in a glass capillary, attached to the vessel enclosing the sample. The meniscus is followed either visually, by a cathetometer or on film⁵⁻⁷. Other methods are based on measurements of electrical resistance⁸ and capacitance⁹.

In this paper a conductivity dilatometer is presented for automatic reading of the liquid level.

Description of the apparatus (Figure 1)

The dilatometer consists essentially of a Perspex tube (b) connected by a perspex side-arm (c) to a glass capillary (d). The brass bottom of the vessel (e) is constructed robustly. The Perspex cap (f) is conically shaped so as to remove air from the dilatometer when the cap is screwed on the Perspex tube. The sample (g) is held by two tempered steel clamps. The lower sample-clamp (h) is screwed in the bottom using lever (i). A steel bar (j), going outwards through a Teflon sealing tube (k), provides the connection between the upper

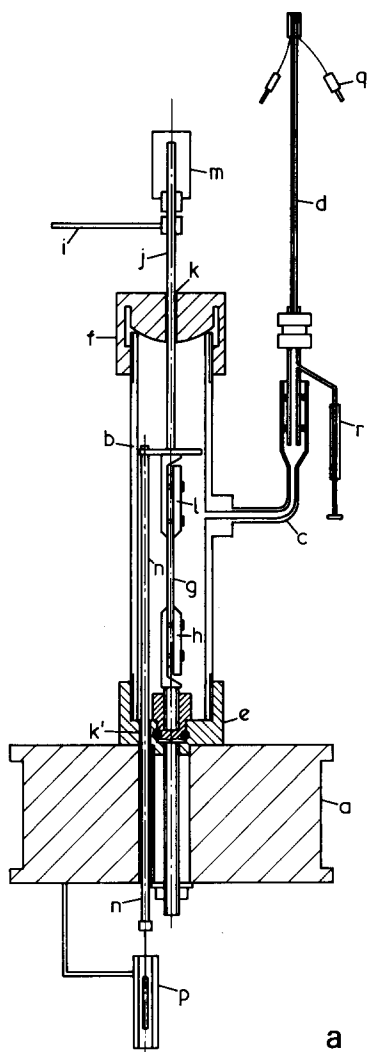

Figure 1a Semi-technical drawing of the dilatometer (side-view), mounted on the cross-head (a) of the Instron tensile tester. See text for explanation of the letters. Dimensions: water container (b): diameter 4 cm, height 32 cm; capillary (d): inside diameter 2.0 mm, height 20 cm; copper wires (q) inside the capillary: diameter 0.2 mm; specimen (g): 50 x 13 x 3 mm

sample-clamp (l) and the Instron clamp. A sheet of brass (m) mounted on this bar like a turnable weather-vane, fits exactly to the Instron clamp and ensures the centring of the bar.

During a tensile test the position of the bar (j) does not affect the position of the meniscus in the capillary, because of the presence of a compensation bar (n) with exactly the same diameter going through a Teflon sealing tube (k'). The elongation of the sample is registered by following the displacement of the lower sample-clamp (h) relative to the upper stationary clamp (f) by means of an inductive displacement transducer (p) (HBM-W10) (Hottinger-Baldwin-Messtechnik, Darmstadt, Germany) and a transducer amplifier (HBM, KWS/T-5).

The change of the water level in the capillary is measured as follows: two parallel copper wires (g), stretched along the inside of the capillary, are connected to a conductivity meter (Philips, PW 9501). The signal of the conductivity meter is directly proportional to the water level in the capillary, and therefore directly proportional to the change in sample volume. For calibration the water volume in the dilatometer can be varied 0.100 ml by injecting this volume in the capillary using an attached precision syringe

(r). The signals of the conductivity meter (ΔV) and the load transducer amplifier of the Instron tensile tester (F) are simultaneously registered on an xyy' -recorder (Hewlett-Packard, Moseley 506 A) as functions of the signal of the displacement transducer amplifier (ΔL) (Figure 2). A zero depression apparatus (Philips PT 1431) is used to match the starting-signal of the conductivity meter with the electrical zero of the xyy' -recorder.

PROPERTIES OF DILATOMETER SYSTEM

Linearity and reproducibility

The conductivity change *versus* volume change, in the most frequent range (0–0.1 ml), has a maximum deviation from linearity of about $\pm 2\%$. The water level in the capillary can be varied using the precision injection syringe. Calibration is achieved by zero-point depression and adjustments of conductivity meter and recorder sensitivities. This procedure ensures a reproducible performance of the whole liquid level detector system.

Stability

Stability, or constancy of the liquid level, depends mainly on temperature fluctuations. Under normal experi-

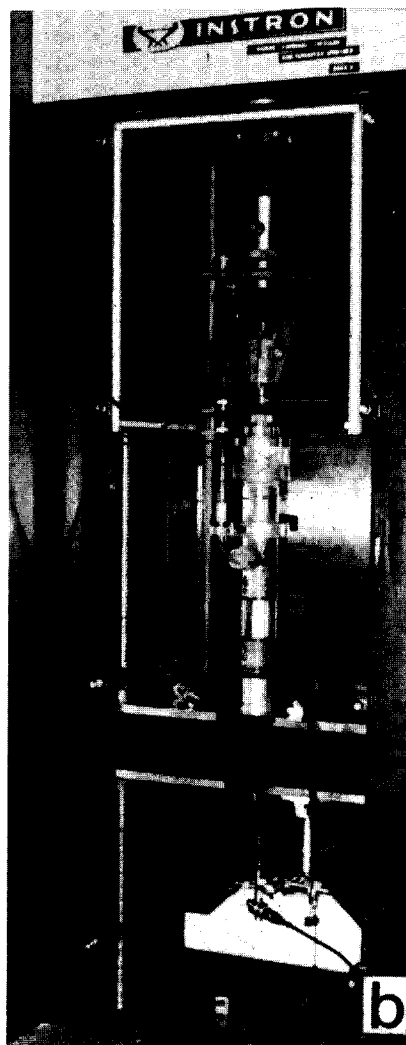

Figure 1b Photograph of the dilatometer, mounted on the cross-head of the Instron tensile tester

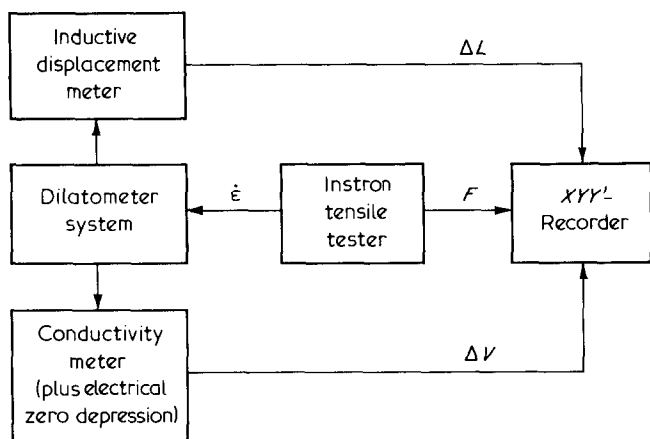

Figure 2 Block-scheme of the system for measuring simultaneously volume change (ΔV) and load (F) versus elongation (ΔL) during a tensile test of a specimen ($\dot{\epsilon} = \text{constant}$)

mental conditions a stability of better than 2×10^{-4} ml/min is attainable. In tensile tests, with a duration of some minutes, temperature regulation of the dilatometer is not required.

Deformation of the dilatometer system

During a tensile test the dilatometer system itself is also subjected to forces. This may give rise to volume changes and deviations from the actual volume strain. Lateral forces are minimized by optimal centring of the dilatometer system in the Instron tester and by a well centred position of the specimen in the clamps (Figure 3). Deformation of the vessel bottom, caused by a tensile load, is made negligible by its solid construction. Contributions to elongation, due to elastic deformation of bar *j* (Figure 1), tolerance of tensile tester etc., are avoided by measuring the elongation as described previously. From test experiments (maximum load 250 kg) it appears, that the system elasticity is 22×10^{-7} cm/N and that the volume increase of the system is 4.4×10^{-7} ml/N.

From these numbers it can be derived, that the initial Poisson ratio, being of physical importance with respect to the elastic deformation of the specimen, is measured with a systematic deviation of about 1% too low. Beyond a yield point the load is more or less constant and the slope of the volume curve is practically not affected.

Response

The response properties of the detector system depend mainly on those of the conductivity meter (Philips PW 9501). This conductivity meter is not designed for dynamic experiments. If the system is abruptly subjected to a linear increasing volume change (0.02 ml/sec), i.e. the maximum volume increase per second for a sample with dimensions $50 \times 13 \times 3$ mm subjected to a strain rate of 3 cm/min, 0.2 sec is needed to register the correct slope value. This response time does not affect essentially the measurements with respect to Poisson ratios and slope values.

Subjecting the system to a 0.1 ml step-signal, as may occur at sample failure, there is a 10% overshoot. After about 1.5 sec the system gives the correct value.

The elastically strained upper bar (Figure 1, *j*) relaxes immediately at break of the specimen and causes a jump of the plunger of the displacement transducer, connected through the compensation bar (*n*) to the upper bar (*j*).

Friction, initial level drop, compensation

The compensation bar (Figure 1, *n*) and the upper bar (*j*) encounter a constant friction (1–2 kg) in the Teflon sealing tubes (*k*, *k'*) during a tensile test. This friction force causes a small constant deformation of the dilatometer vessel, resulting in a small initial drop of the water level in the capillary ($\leq 2 \times 10^{-3}$ ml).

Volume changes due to non perfect volume compensation of the movement of the bar (*j*) are less than $\pm 10^{-4}$ ml per cm displacement of this bar.

Detection limits

The maximum sensitivity of the level detector is very high, volume changes less than 10^{-6} ml are detectable. However, the lower detection limit is mainly determined by the stability properties of the dilatometer system. The upper detection limit depends on the dimensions of the capillary (here 0.6 ml).

GEOMETRY AND PREPARATION OF THE SPECIMENS

The dilatometer, as described above allows the determination of ΔV versus ΔL . The equation of the experimental curve is:

$$\Delta V = (1 - 2\nu)A_0\Delta L$$



Figure 3 Photograph of the dilatometer clamping-system situated in a device to obtain a centred alignment of the specimen and the clamps

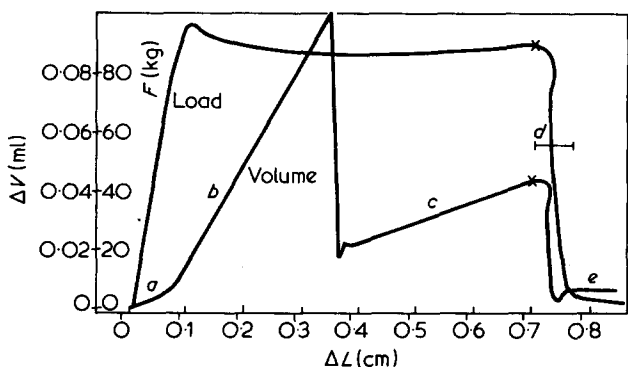

Figure 4 Experimental curves of HIPS (Styron 453, Dow Chemical). Load (F) and volume change (ΔV) registered versus elongation (ΔL). Strain rate, 0.40 min^{-1} . Specimen dimensions: $50.00 \times 12.38 \times 2.87 \text{ mm}$. Explanation of the letters: (a) elastic behaviour: initial Poisson ratio is 0.39; (b) yielding: $\Delta V/V_0$ versus $\Delta L/L_0$ indicates slope 0.97; (c) yielding, recorder sensitivity reduced (5x); (d) break, here the response properties of the measuring system are insufficient; (e) volume relaxation after break

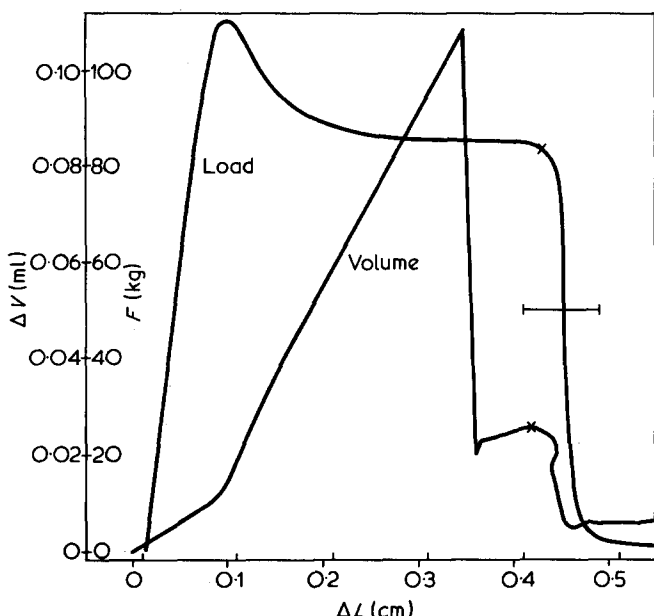

Figure 5 Experimental curve of a blend, containing 92.5 wt % PS and 7.5 wt % LDPE. Load (F) and volume change (ΔV) registered versus elongation (ΔL). Strain rate, 0.40 min^{-1} . Specimen dimensions $50.40 \times 12.27 \times 2.92 \text{ mm}$. Initial Poisson ratio is 0.32, yielding: $\Delta V/V_0$ versus $\Delta L/L_0$ indicates slopes from 1.14 to 1.00 (l)

where A_0 is the cross-sectional area of the rectangular specimen at the beginning of the experiment. The specimens are machined with parallel sides from compression moulded sheets. The distance between the grips is 50 mm, and the cross-section is $13 \times 3 \text{ mm}^2$.

SOME EXPERIMENTAL CURVES

High impact polystyrene

As crazing of high impact polystyrene HIPS (Styron 453 natural, Dow Chemical) is well known¹ this material is very suitable for testing and demonstrating the dilatometer system. The experimental curves are presented in Figure 4.

The initial Poisson ratio is 0.39 and from the second part of the curve it can be derived, that a graph of $\Delta V/V_0$ versus

$\Delta L/L_0$ has almost unit slope, indicating crazing as the main yielding deformation mechanism.

The volume drop after failure can be explained by the recovery of the elastically strained matrix of the sample after failure while the voids are forced to close. The relative standard deviation of the volume slope is 1–2% for HIPS samples.

Blend containing polystyrene (PS) and low density polyethylene (LDPE)

The experimental curves of a PS/LDPE blend (92.5:7.5 by weight) are reproduced in Figure 5. The unexpected low Poisson ratio is 0.32 ($\nu_{PS} = 0.33$, $\nu_{PE} = 0.48$) is a consequence of poor adhesion between the PE particles and the PS matrix².

The high slope values (1–1.14) of the second part of the volume curve, $\Delta V/V_0$ versus $\Delta L/L_0$ can be explained in terms of separate contributions of the matrix and the crazes to the total volume strain. A quantitative model on this subject will be published soon.

Blend containing PS, LDPE and block copolymer of PS and LDPE

The experimental curves of a blend, containing 68.0% PS, 17.5% LDPE and 14.5% PS-*b*-LDPE (composition 1:1), are reproduced in Figure 6. The initial Poisson ratio is 0.44 and reflects a good adhesion between the phases. This relatively high value indicates also that here the soft material (PE plus blockcopolymer, both Poisson ratios ≈ 0.48) forms a more or less continuous phase instead of a dispersed one². The second part of the volume curve shows, that the slope of a graph of $\Delta V/V_0$ versus $\Delta L/L_0$ is 0.67, indicating that both crazing (67%) and shearing (33%) contribute to the yielding deformation.

CONCLUSIONS

A dilatometer system for use in tensile tests has been constructed successfully. From the volume curves the slope values and Poisson ratios can be determined within 2–3%.

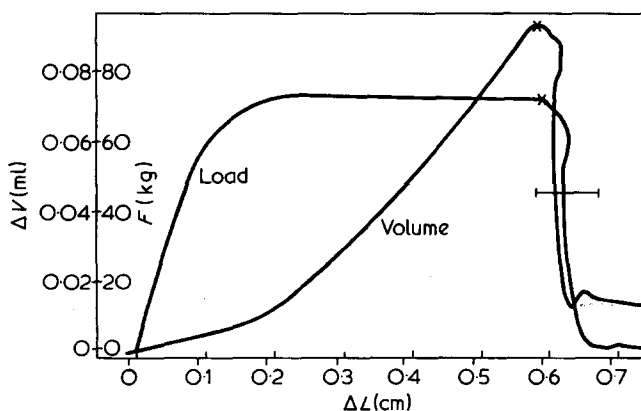

Figure 6 Experimental curve of a blend, containing 68.0 wt % PS, 14.5 wt % LDPE and 17.5 wt % block copolymer PS/PE (1:1). Load (F) and volume change (ΔV) registered versus elongation (ΔL). Strain rate, 0.40 min^{-1} . Specimen dimensions $50.25 \times 12.04 \times 2.88 \text{ mm}$. Initial Poisson ratio is 0.44; yielding: $\Delta V/V_0$ versus $\Delta L/L_0$ indicates slope 0.69

The volume change detector, based on electrical conductivity, has a deviation from linearity of less than 2%, is very sensitive ($<10^{-6}$ ml) and very reliable.

Stability and response properties of the system are better than sufficient for tensile test experiments. Deformation of the dilatometer system, due to the tensile load, has been minimized and affects the measured values of volume change and elongation to a negligible extent.

ACKNOWLEDGEMENTS

Grateful acknowledgement is made to Mr. P. J. Broers and Mr. J. Boekholt for their contributions to the construction of the dilatometer.

REFERENCES

- 1 Bucknall, C. B. 'Toughened Plastics', Applied Science, London 1977, Ch 7
- 2 Coumans, W. J., Heikens, D. and Sjoerdsma, S. D. *Polymer* in press
- 3 Darlington, M. W. and Saunders, D. W. *J. Phys.* 1970, E3, 511
- 4 Cessna, L. C. *Polym. Eng. Sci.* 1974, 14, 696
- 5 Holt, W. L. and McPherson, A. T. *J. Res. Nat. Bur. Stand.* 1936, 17, 658
- 6 Sekhar, N. and van der Hoff, B. M. E. *J. Appl. Polym. Sci.* 1971, 15, 169
- 7 Truss, R. W. and Chadwick, G. A. *J. Mat. Sci.* 1976, 11, 111
- 8 Bernatchez, P. and Goutier, D. *Rev. Sci. Instrum.* 1973, 44, 1790
- 9 Seymour, R. B. and Stahl, G. A. *Rev. Sci. Instrum.* 1975, 46, 1467