

Pattern-based analysis of UML activity diagrams

Citation for published version (APA):

Wohed, P., Aalst, van der, W. M. P., Dumas, M., Hofstede, ter, A. H. M., & Russell, N. C. (2004). *Pattern-based analysis of UML activity diagrams*. (BETA publicatie : working papers; Vol. 129). Technische Universiteit Eindhoven.

Document status and date:

Published: 01/01/2004

Document Version:

Publisher's PDF, also known as Version of Record (includes final page, issue and volume numbers)

Please check the document version of this publication:

- A submitted manuscript is the version of the article upon submission and before peer-review. There can be important differences between the submitted version and the official published version of record. People interested in the research are advised to contact the author for the final version of the publication, or visit the DOI to the publisher's website.
- The final author version and the galley proof are versions of the publication after peer review.
- The final published version features the final layout of the paper including the volume, issue and page numbers.

[Link to publication](#)

General rights

Copyright and moral rights for the publications made accessible in the public portal are retained by the authors and/or other copyright owners and it is a condition of accessing publications that users recognise and abide by the legal requirements associated with these rights.

- Users may download and print one copy of any publication from the public portal for the purpose of private study or research.
- You may not further distribute the material or use it for any profit-making activity or commercial gain
- You may freely distribute the URL identifying the publication in the public portal.

If the publication is distributed under the terms of Article 25fa of the Dutch Copyright Act, indicated by the "Taverne" license above, please follow below link for the End User Agreement:

www.tue.nl/taverne

Take down policy

If you believe that this document breaches copyright please contact us at:

openaccess@tue.nl

providing details and we will investigate your claim.

Pattern-based Analysis of UML Activity Diagrams

Petia Wohed¹, Wil M.P. van der Aalst^{2,3}, Marlon Dumas³, Arthur H.M. ter Hofstede³
and Nick Russell³

- ¹ Centre de Recherche en Automatique de Nancy, Université Henri Poincaré, Nancy 1
BP239, 54506 Vandoeuvre les Nancy, France
petia.wohed@cran.uhp-nancy.fr
- ² Department of Technology Management, Eindhoven University of Technology
GPO Box 513, NL5600 MB Eindhoven, The Netherlands
w.m.p.v.d.aalst@tm.tue.nl
- ³ Centre for Information Technology Innovation, Queensland University of Technology
GPO Box 2434, Brisbane QLD 4001, Australia
{m.dumas, a.terhofstede, n.russell}@qut.edu.au

Abstract. The Unified Modelling Language (UML) is a well-known family of notations for software modelling. Recently, a new version of UML has been released. In this paper we examine the Activity Diagrams notation of this latest version of UML in terms of a collection of patterns developed for assessing control flow and data flow capabilities of languages used in the area of process-aware information systems. The purpose of this analysis is to assess relative strengths and weaknesses of control and data flow specification in Activity Diagrams and to identify ways of addressing potential deficiencies. In addition, the pattern-based analysis will yield typical solutions to practical process modelling problems and expose some of the ambiguities in the current UML 2.0 draft specification [9].

Keywords: UML, Activity Diagrams, Workflow Patterns, YAWL

1 Introduction

The Unified Modelling Language (UML), not seldom referred to as a de facto standard for software modelling, has recently undergone a significant upgrade to a new major version, namely UML 2.0¹. Being a multi-purpose language, UML offers a variety of notations for capturing different aspects of software structure and behaviour. One of these notations, namely Activity Diagrams (AD), is intended for modelling computational and business/organisational processes.

If the UML AD notation is to be adopted as a standard for business process modelling, it should compare favourably with other notations in this space. Evaluating and comparing modelling notations, particularly in the area of business processes, is a delicate endeavour. Evaluations in terms of case studies may lead to valuable insights, but the conclusions are difficult to generalise due to their restricted scope. On the other hand, evaluations in terms of ontologies, such as the BWW ontology [6, 10], lead to coarse-grained results since these ontologies are composed of highly general concepts

¹ <http://www.uml.org>

whose pertinence and manifestation in the context of business processes have not yet been studied.

The workflow patterns [3, 11] constitute a more specialised evaluation framework. Originally developed as an instrument to evaluate languages supported by workflow systems, these patterns have been used by several authors to evaluate languages for process-aware information systems development [5, 14, 13, 8]. Also, while originally restricted to the control flow perspective (i.e. the ordering of activities) these patterns have been extended to the data perspective². In addition, a workflow definition language (namely YAWL [1]) capturing most of the patterns has been designed and implemented.

This paper provides an evaluation of UML AD (version 2.0) in terms of the workflow patterns. The contributions of this evaluation are:

- The identification of some limitations in UML AD and recommendations for addressing these with minimal disruption to the current design of the language.
- Discussions on how to capture the patterns in UML AD which provide elements of reusable knowledge for process designers that encounter these patterns.
- A critical analysis of the UML 2.0 AD Draft Specification of the OMG, e.g., pointing out many ambiguities in the current specification [9].

Note that an evaluation of UML AD version 1.4 in terms of these patterns has been previously reported [5]. This evaluation led to the identification of limitations partly addressed by UML 2.0. However, while in UML 1.4 activity diagrams are based on statecharts, in UML 2.0 they have a semantics defined in terms of token flow inspired by (though not fully based on) Petri nets. Thus, the evaluation of UML 2.0 leads to quite different results than the one for UML 1.4. Also, it may be noted that a previous attempt at evaluating UML 2.0 AD has been conducted by White [13], who compares UML AD with the Business Process Modelling Notation (BPMN) designed by himself. However, some of the results reported by White may be questioned as explained in the rest of this paper. Furthermore, neither White's evaluation, nor the previous evaluation of UML 1.4 AD cover the data perspective.

The rest of the paper is organised as follows. Section 2 briefly introduces the UML 2.0 AD notation. Sections 3 and 4 report on the evaluation of UML AD in terms of the control-flow and the data patterns respectively. Finally, Section 5 summarises the results and concludes.

2 Overview of UML2.0 AD

In UML 2.0 AD the fundamental unit of behaviour specification is *Action*. “An action takes a set of inputs and converts them to a set of outputs, though either or both sets may be empty.” [9], p. 203³. Actions may also modify the state of the system. There are three types of actions, namely: *Invocation Actions*, used for performing operation calls, signal sending and accept event actions; *Read and Write Actions*, for accessing and modifying objects and their values; and *Computation Actions*, transforming input values into output values. The language provides further a very detailed action taxonomy,

² Extensions are underway to cover the other perspectives, but these are not discussed here.

³ In the remainder of this paper page numbers without reference refer to [9].

where more than 35 different action types are specified. However, a deep discussion of them is outside the scope of this paper and in Figure 1a we only present the action types that we have found to be useful in our evaluation. These are the generic *Action* concept, *Accept Event Action*, *Send Signal Action*, and *Call Behavior Action*.

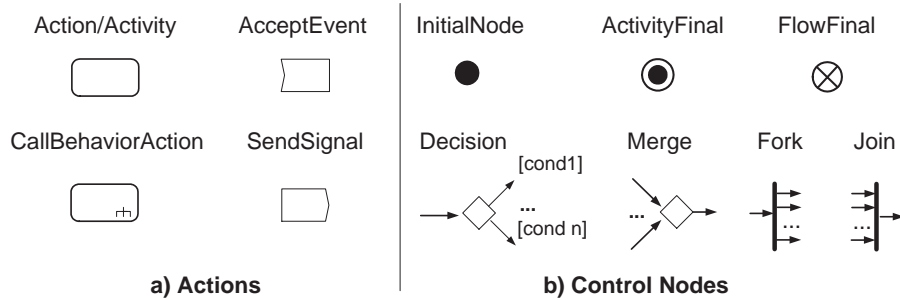

Fig. 1. UML AD, main symbols

Furthermore, to present the overall behaviour of a system, the concept of *Activity* is used. Activities are composed of actions and/or other activities and they define dependencies between their elements. Graphically, they are composed of nodes and edges. The edges, used for connecting the nodes, define the sequential order between these. Nodes represent either *Actions*, *Activities*, *Data Objects*, or *control nodes*. The various types of control nodes are shown in Figure 1b.

3 Workflow Control Flow Patterns in UML2.0 AD

In this section, an analysis of UML AD version 2.0 is provided in terms of the control flow patterns as defined in [3]. In this analysis the YAWL language [2] is used as a reference realisation of the patterns (where appropriate). As YAWL is a formally defined language its solutions for the patterns leave no room for ambiguities. Due to space restrictions the patterns themselves will not be discussed in detail here, for this the reader is referred to [3].

3.1 Basic control flow patterns, multi-choice and multi-merge

The first seven control flow patterns, namely sequence, parallel split, synchronisation, exclusive choice, simple merge, multi-choice, and multi-merge are directly supported in UML 2.0 AD. In fact, the first five of these patterns are supported by basically all process modeling and description languages and they correspond to control flow constructs defined by the Workflow Management Coalition [12].

Figure 2 shows the solutions to the first seven patterns in UML 2.0 AD and, as a point of comparison, in YAWL. The following paragraphs briefly discuss these solutions. Descriptions of the patterns are not included as they are relatively straightforward and they can be found in [3].

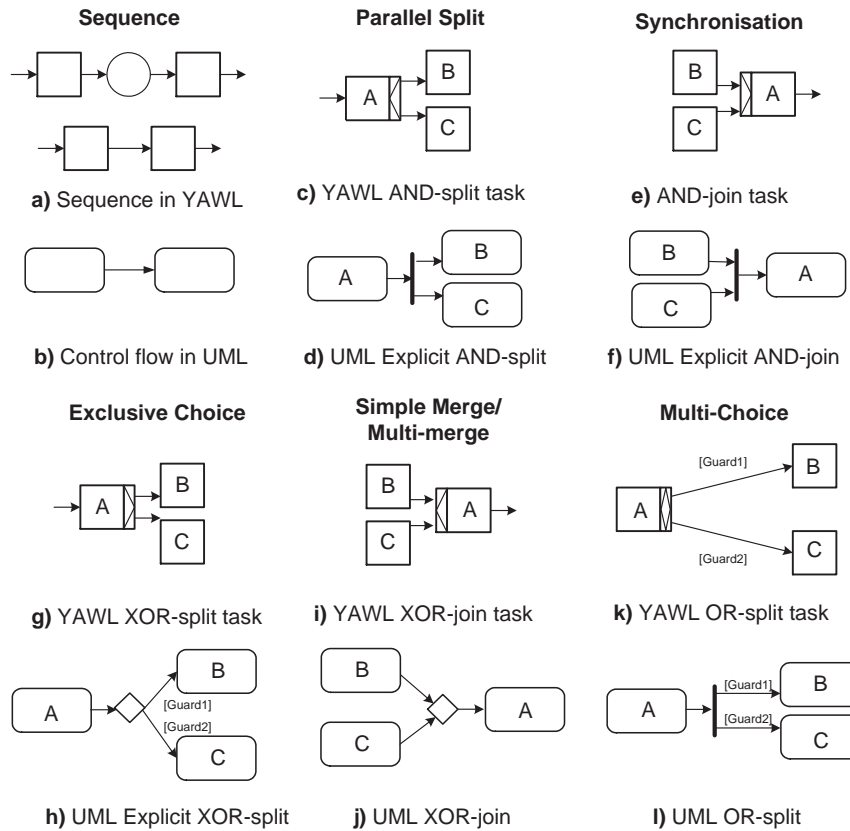

Fig. 2. Elementary Control Flow in UML and in YAWL

There are two ways of representing sequence in YAWL (see Figure 2a). Two tasks can be connected directly, or they can have a condition (which corresponds to the concept of “place” in Petri nets) in between. In case two tasks are connected directly the condition in between exists in a formal sense, it is just not shown graphically. In UML, this basic pattern is solved in a very similar manner (see Figure 2b), i.e. through a control flow arrow (p. 315), though UML does not explicitly support the notion of state hence there is no equivalent concept to the YAWL condition.

The parallel split is captured in YAWL by an AND-split (see Figure 2c). In UML it is captured by a ForkNode, represented as a bar with one incoming edge and two or more outgoing edges (p. 334) (see Figure 2d). Furthermore, as “an action may have sets of incoming and outgoing activity edges...” (p. 280) and “when completed, an action execution offers [...] control tokens on all its control edges” (p. 281) the parallel split can also be modelled implicitly, by drawing the outgoing edges directly from the action node and omitting the fork node.

Synchronisation in YAWL is captured through the AND-join (see Figure 2e). In UML 2.0 AD, the construct used for synchronisation is the JoinNode, i.e. a control node depicted as a bar with multiple incoming edges and one outgoing edge (p. 339). Furthermore, as a JoinNode provides the possibility for the specification of a condition (through a joinSpec expression) the default value “and” has to be used to guarantee synchronisation of all its incoming edges (Figure 2f). Similarly to the parallel split solution, here also an implicit notation, where the JoinNode is omitted, is offered. The semantics of this solution is that “an action execution is created when all its [...] control flows prerequisites are satisfied” (p. 281).

The exclusive choice in YAWL is captured by the XOR-split (see Figure 2g). In the YAWL environment, predicates specified for outgoing arcs of an XOR-split may overlap. In case multiple predicates evaluate to true, the arc with the highest preference (which is specified at design time) is selected. If all predicates evaluate to false, the default arc is chosen. The treatment of the XOR-split in YAWL guarantees that no matter what predicates are specified the intended behaviour of an XOR-split, the choice for exactly one outgoing branch, is guaranteed. In UML, a DecisionNode, graphically depicted by a diamond with one incoming edge and multiple outgoing edges, is used to represent this pattern (p. 320). The decision condition can be defined through “guards” attached to the outgoing edges (see Figure 2h). If the guard of more than one of the outgoing edges evaluates to true, the semantics of the construct depicted in Figure 2h is not defined (p. 320) and hence the “guards” should be made exclusive. A predefined “else” branch can be used which is chosen when none of the guards of the other branches evaluates to true. However, the use of “else” is optional. Furthermore, “decisionInput” behaviour (attached to the decisionNode) can be used in combination with “guard” conditions. “If a decision input behaviour is specified, then each token is passed to the behaviour before guards are evaluated on the outgoing edges. [...] it [the behaviour] may be run many times on the same token before the token is accepted by those edges.” (p. 320) While “Decision input behaviour are introduced to avoid redundant recalculation in guards” (p. 322), their semantics is not clearly defined.

In YAWL, the simple merge pattern is expressed using the XOR-join (see Figure 2i). In UML this pattern is represented with the use of a MergeNode, a diamond with several incoming edges and one outgoing edge (see Figure 2j). These solutions, for both YAWL and UML AD, also constitute a solution to the Multi-merge pattern where parallelism may occur in the branches preceding the join and each completion of such a branch leads to (another) execution of the branch following the join.

In the multi-choice pattern, in contrast with the exclusive choice, multiple outgoing branches may be chosen. The multi-choice in YAWL is captured through the OR-split (see Figure 2k). It should be noted that in the YAWL environment at least one outgoing branch needs to be chosen, which makes its OR-split slightly less general than the pattern. In YAWL, the selection of at least one branch is guaranteed by the specification of a default branch which is chosen if none of the predicates evaluate to true (including the predicate associated with the default branch). In UML AD, the solution for this pattern is the same as the solution for the parallel split, except that in addition guards controlling which branches shall be started have to be defined for the edges departing from the ForkNode (see Figure 2l).

one to complete would pass a token to its corresponding outgoing edge (i.e., a will pass a token to A and b will pass a token to B). Then as “the join specification is evaluated whenever a new token is offered on any incoming edge” (p. 339) the JoinSpec condition will evaluate to true and the execution of action c will proceed without awaiting for the completion of the execution of the remaining action.

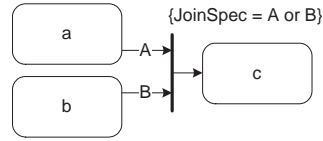

Fig. 4. Incorrect attempt to capture synchronising merge

White [13] provides a tentative solution to this pattern. However, there are problems with this solution too. Firstly, his solution assumes the existence of a corresponding OR-split, hence it would not be general enough to work in an unstructured context. Secondly, in the join he uses “a condition expression that controls how many Tokens must arrive from the incoming control flow before a Token will continue through the outgoing control flow” ([13], p. 11). This expression is not given and it is not clear how it could be determined how many tokens to expect. In addition, even if somehow this could be detected, how can one deal with multiple tokens arriving on the same branch as a result of loops?

3.3 Discriminator⁵

Description A form of synchronisation for an activity where out of a number of incoming branches executing in parallel, the first branch to complete initiates the activity. When the other branches complete they do not cause another invocation of the activity. After all branches have completed the activity is ready to be triggered again (in order for it to be usable in the context of loops). The discriminator is a special case of the N out of M join (sometimes referred to as *partial join* [4]) as it corresponds to a 1-out-of- m join.

Solution in YAWL In YAWL, one of the ways to capture the discriminator involves the usage of cancellation regions (cf. [2]). The discriminator is specified with a multi-merge and a cancellation region encompassing the incoming branches of the activity (see Figure 5a). In this realisation, the first branch to complete starts the activity involved, which then cancels the other executing incoming branches. This is not in exact conformance with the original definition of the pattern (as it actually cancels the other branches), but this choice is motivated by the fact that it is clear in this approach what the region is that is in the sphere of the discriminator giving it a clearer semantics.

Solution in UML The solution in UML AD (see Figure 6) uses the concept of interruptible region which is very similar to the notion of cancellation region in YAWL.

⁵ The term discriminator comes from Verve Workflow.

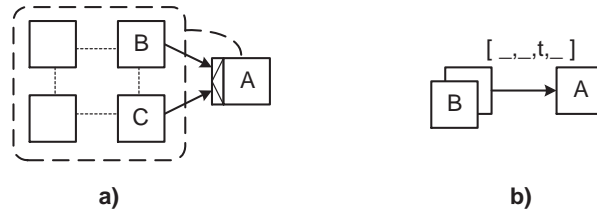

Fig. 5. Discriminator in YAWL

Hence, the solution is very close to the solution in YAWL. Furthermore, due to the use of weights it also easily generalises to the n-out-of-m join. YAWL provides direct support for n-out-of-m join too, but the solution there is based on the concept of thresholds within the multiple instances task construct. This solution is shown in Figure 5b and the multiple instances task concept is further discussed in section 3.5.

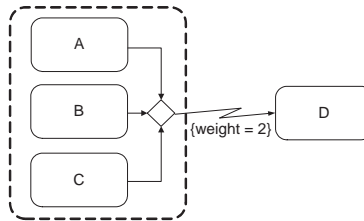

Fig. 6. The 2-out-of-3 join in UML AD

White [13] presents a solution which uses an or-expression which checks for each incoming branch whether it has completed. He claims that the first token to arrive will proceed the flow and the other tokens will not. The expression given seems to be an annotation which is not part of the UML AD notation. In addition, it is unclear how this would work if the discriminator is to be activated more than once (e.g. because it appears in a loop).

3.4 Structural patterns

In this section we briefly consider the patterns covering arbitrary cycles and implicit termination.

Description of Arbitrary Cycles Some process specification approaches only allow the specification of loops with unique entry and exit points. *Arbitrary cycles* are loops with multiple ways of exiting the loop or multiple ways of entering the loop.

Both YAWL and UML AD (also pointed out by White [13]) support arbitrary cycles.

Description of Implicit Termination A given subprocess should be terminated when there is nothing else to be done. In other words, there are no active activities in the sub-

process and no other activity can be made active (and at the same time the subprocess is not in deadlock). This termination strategy is referred to as *implicit termination*.

Solution in YAWL YAWL does not support implicit termination as to force workflow designers to carefully think about workflow termination.

Solution in UML UML AD provide direct support for this pattern. There are two notions for capturing termination namely, ActivityFinal and FlowFinal (see Figure 1). “A FlowFinal destroys all tokens that arrive at it” (p. 333). It does not terminate the whole activity but only a flow within it. Implicit termination is then captured by ending every thread within an activity with a FlowFinal node.

3.5 Multiple instances patterns

In this section focus is on the class of so-called “multiple instances” (MI) patterns. These patterns refer to situations where there can be more than one instance of a task active at the same time in the same case. The first of these patterns is concerned with the creation of multiple instances.

Description of MI without Synchronisation Within the context of a single case (i.e., process instance) multiple instances of an activity can be created, i.e., there is a facility to spawn off new threads of control. Each of these threads of control is independent of other threads. Moreover, there is no need to synchronise these threads.

Solution of MI without Synchronisation in UML AD Consider the UML AD example in Figure 7a which is taken from [9] (Figure 253, p. 333). This UML AD provides a partial solution to the pattern. Instances of “Install Component” are “spawned-off” through a loop and the conditions associated with the DecisionNode will determine how many such instances will ultimately be created.

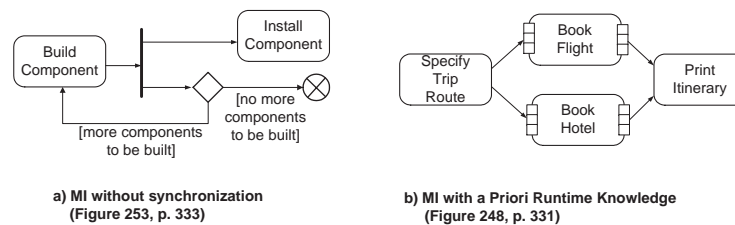

Fig. 7. Multiple Instances in UML AD, solutions reprinted from [9]

The next three patterns deal with the synchronisation of multiple instances. The first such pattern is **Multiple instances with design time knowledge** and can typically be supported by replicating the activity involved as many times as required. This is possible in UML AD. The other two patterns deal with synchronisation of multiple instances where the number of instances is not known at design time.

The pattern **Multiple Instances with a Priori Runtime Knowledge** captures the situation when for one case an activity is enabled multiple times. The number of instances of a given activity for a given case varies and may depend on characteristics of

the case or availability of resources, but is known at some stage during runtime, before the instances of that activity have to be created. Once all instances are completed some other activity needs to be started.

The pattern **Multiple Instances without a Priori Runtime Knowledge** is based on the previous pattern with the further complication that the number of instances to be created (and later on synchronised) are not known at any stage during runtime, before the instances have to be created. Even while some of the instances are being executed or already completed, new ones can be created.

Solutions in YAWL YAWL provides direct support for the multiple instance patterns. A multiple instance task in YAWL has four attributes: one expresses the minimum number of instances to be created; one the maximum number; one specifies a threshold for continuation (where the semantics is that if all created instances have completed or the threshold has been reached the multiple instance task can complete); and finally an attribute with the possible values *static* and *dynamic* which indicates whether or not it is possible to create new instances when a multiple instance task has already been started (see Figure 8).

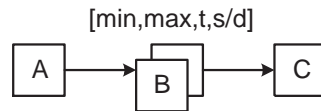

Fig. 8. MI in YAWL

Solution of Multiple Instances with a Priori Runtime Knowledge in UML AD Here too we consider a UML AD solution taken from [9] (Figure 248, p. 331) as the basis for our discussion (see Figure 7b). In this example, the notion of *ExpansionRegion*, where the region consists of a single action, is used twice, once for the Book Flight action and once for the Book Hotel action. The small rectangles, divided into compartments and attached to a region, are meant to represent the input/output collections of elements, for the region. The action/s in the region is/are executed once for each element from the input collection (“or once per element position, if there are multiple collections” (p. 326)). “On each execution of the region, an output value from the region is inserted into an output collection at the same position as the input element” (p. 325). (The semantics of differing numbers in the inputs and their corresponding output collections is not defined.) Furthermore, the way in which the multiple instances shall be executed, i.e., parallel or iterative, is defined through a setting of the *ExpansionRegion* node. The UML specification is not explicit about completion of an *ExpansionRegion*, only about their initiation. We assume here that it is completed when all its instances have completed.

Solution of Multiple Instances without a Priori Runtime Knowledge in UML AD This pattern is not directly supported in UML AD. The notion of expansion region can not be used here as once an expansion region receives the required input collection(s) no values can be added afterwards. There are however workarounds that achieve the

required functionality for this pattern. The first solution, which is depicted on the left in Figure 9, is inspired by Figure 251, p. 332, from the UML specification [9] and by the solution provided by White [13]. The idea is to keep track of two variables, one representing the number of instances created so far, and one, a boolean, capturing whether there is a need to create more instances. The solution in Figure 9 is however more precise as to how synchronisation is to occur than both the solution provided by White [13] and the solution shown in [9]. Another workaround is to use object streams and weights. This solution is depicted on the right in Figure 9 and exploits the fact that both the guard and the weight of an edge need to be satisfied (p. 294).

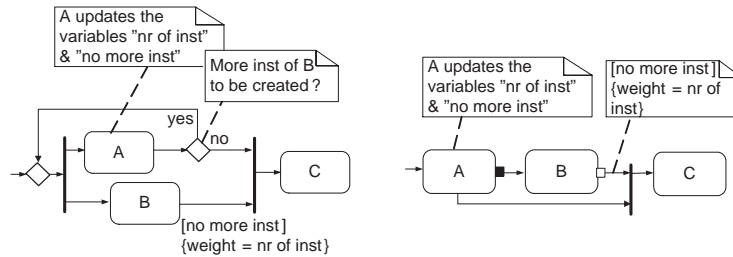

Fig. 9. Two solutions to MI without a Priori Runtime Knowledge

3.6 Deferred choice

Description A point in the process where one of several branches is chosen. In contrast to the XOR-split, the choice is not made explicitly (e.g. based on data or a decision) but several alternatives are offered to the environment. However, in contrast to the OR-split, only one of the alternatives is executed. This means that once the environment activates one of the branches the other alternative branches are withdrawn. It is important to note that the choice is delayed until the processing in one of the alternative branches is actually started, i.e. the moment of choice is as late as possible.

Solution in YAWL YAWL is based on Petri nets and therefore directly supports the deferred choice. A condition (i.e., the YAWL term for a place) is specified as input to the activities that can result from the choice. At runtime, the alternative that is chosen consumes the token thus disabling the other alternatives.

Solution in UML This pattern is captured in UML AD by the use of a fork and a set of accept signal actions, one preceding each action in the choice. In addition, an interruptible activity region encircling these signals is defined (see Figure 10). The semantics is that the first signal received will enable and trigger the activity following it (follows from the definition of AcceptEventAction on p. 217) and at the same time disable the rest of the activities included in the deferred choice by terminating all other remaining receive signal actions in the region (follows from the definition of InterruptibleActivityRegion on p. 336). This solution is identical to the solution proposed by White [13].

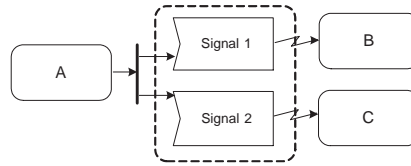

Fig. 10. Deferred choice (solution identical to this in [13])

In [5], where an evaluation of UML AD version 1.4 was presented, this pattern was captured using a “waiting state”. This solution is not applicable for UML AD version 2.0 as the notion of state is not supported anymore.

3.7 Interleaved parallel routing

Description Several activities are executed in an arbitrary order: Each activity is executed, the order is decided at run-time, and no two activities are executed at the same moment (i.e. no two activities are active for the same process instance at the same time).

Solution in YAWL Given that YAWL is based on Petri nets, the idea of a mutex place can be used as presented in [3]. This solution is shown in Figure 11. The finesse of this solution is that it is general enough to also capture the case where sequences of activities have to be interleaved. In the figure, the sequences to be interleaved are A, B with C, D . It is important that A is always executed before B and likewise, C before D (on top of the requirement that no two actions are executed at the same time).

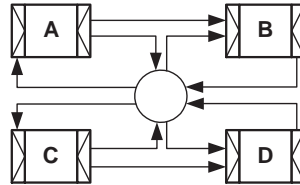

Fig. 11. Interleaved Parallel Routing in YAWL

Solution in UML Similarly to UML AD version 1.4, this pattern is not directly supported in UML 2.0 although a workaround solution can be designed using signals that act as semaphores. This is due to the absence of the notion of state (or the notion of “place” as supported in Petri nets). A workaround solution is shown in Figure 12. Before an action can start this signal needs to have been received, and after the completion of an activity this signal needs to be sent as to indicate that another activity may now execute. In this solution, an action can start after the preceding receive signal action received the signal S . After it completes, the following action sends the signal again so that another action can be executed. As this other action may be in the same thread (e.g. after A it should be possible to execute not only C , but also B) there is a subtle issue

of avoiding that an action of another thread will always “grab” the signal. This would occur if the send and the receive signals were put in sequence, rather than in parallel, after completion of an activity, for activities not last in a thread. The solution presented in Figure 12 assumes that 1) a signal can be sent from an action in a flow to an action in the same flow, 2) even though there may be multiple receivers ready to receive a signal only one of them will actually consume it (this is supported by the statement “[...] only one action accepts a given event, even if the event would satisfy multiple concurrently executing actions.”, p. 217), 3) subthreads of a flow really execute in parallel, and 4) a signal can be sent before anyone is ready to receive it (this is the case as signals are stored in the objects associated with send/receive signal actions).

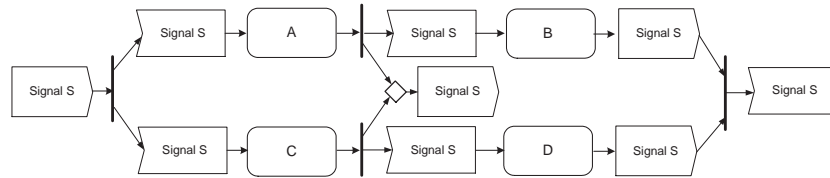

Fig. 12. Interleaved Parallel Routing

The two solutions presented by White [13] are not considered to be satisfactory. The first solution models the pattern by putting a verbal constraint on a couple of parallel activities stating that they are not to be run in parallel. The second solution explicitly orders the threads involved, which is too strong an interpretation of the pattern. For instance, if as earlier the sequences A, B and C, D have to be interleaved and the execution starts with A , White’s solution would restrict the execution order to A, B, C, D , while according to the pattern (and as demonstrated in Figure 11) execution orders A, C, B, D and A, C, D, B should also be possible.

3.8 Milestone

Description A given activity can only be enabled if a certain milestone has been reached which has not yet expired. A milestone is defined as a point in the process where a given activity has finished and an activity following it has not yet started.

Solution in YAWL YAWL directly supports the milestone pattern as it is based on Petri nets and therefore it can exploit the notion of state. A milestone can be realised through the use of arcs back and forth to a condition (which corresponds to the notion of place in Petri nets) testing whether a thread has reached a certain state.

Solution in UML There is no direct support for the milestone in UML AD as the concept of state is not directly supported. A workaround can be devised with the use of signals, see Figure 13. In the solution depicted in this figure, there is a race after the completion of A between continuing B , which has to await the receipt of a signal (Signal 1) to indicate that continuation of the thread is appropriate, and performing some other activity C . Activity C can only be performed after A has completed and

before *B* has started. This is achieved by sending a signal (Signal 2) which triggers another signal (Signal 3) if indeed the other thread is in the correct state. If it is allowed to execute, then after completion, *C* issues a signal (Signal 4) indicating this.

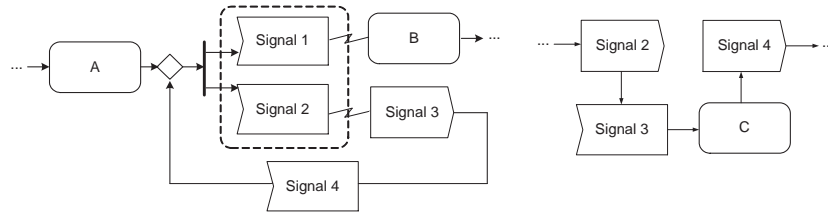

Fig. 13. Milestone

While workarounds exist for the state-based patterns, it is clear that mimicking the concept of a place as it exists in Petri nets through the use of signals may add a lot of complexity and could lead to models that are significantly less comprehensible.

The solution proposed by White [13] does not capture this pattern, as it does not model the expiration of the milestone. According to his solution an activity which *potentially* can be executed at a certain milestone, is *always* executed.

3.9 Cancellation

There are two cancellation patterns: cancel activity and cancel case. As their semantics is straightforward we immediately focus on their solutions in YAWL and UML AD.

Solution in YAWL In Figure 14a execution of task *B* implies cancellation of task *A*, as this task is in the cancellation set of task *B*. In fact, any region can be chosen for cancellation so cancellation sets allow for cancellation of a single task, a whole case, and anything in between.

Solution in UML In UML AD, the cancel activity pattern can be captured as shown in Figure 14b. In this solution an interruptible region is used where apart from activity *A* there is an AcceptEventAction ready to accept a signal indicating that *A* should be cancelled. If such a signal is received during the execution of activity *A*, and as an “interrupting edge” is used, everything in the region (in this case only activity *A*) will be cancelled (p. 337). The solution in Figure 14b is inspired by Figure 260 on p. 338 of the UML specification [9]. It is also identical to the solution presented by White [13]. Note that due to the statement “If an AcceptEventAction has no incoming edges, then the action starts when the containing activity or structured node⁶ does.” (p. 217) no incoming edge is used for the cancellation event.

In UML AD, the cancel case pattern is captured through the ActivityFinal node: “A token reaching an activity final node aborts all flows in the containing activity, that is the activity is terminated, and the token is destroyed.” (p. 298). White [13] offers two

⁶ The interruptible region in our case.

solutions, one along the lines of the approach to cancel activity (by making the process to be cancelled an activity and running it in parallel with the cancellation event) and the other one using the ActivityFinal node.

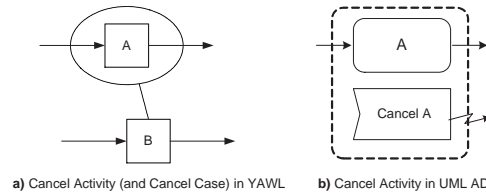

Fig. 14. Cancellation Concepts in YAWL and UML AD

4 Workflow Data Patterns in UML2.0 AD

Recent extensions [11] to the workflow patterns initiative have focussed on identifying and defining generic constructs that occur in the the data perspective of workflow systems. In total forty data patterns have been delineated in five distinct groups:

- **Data visibility** — relating to the manner in which data elements are defined and can be viewed and utilised by various components of a workflow process.
- **Internal data interaction** — focussing on the manner in which data is communicated between active elements within a workflow.
- **External data interaction** — focussing on the manner in which data is communicated between an active element within a workflow and processes, interfaces and data repositories in the external operating environment.
- **Data transfer** — which consider the means by which the actual transfer of data elements occurs between workflow components and describe the various mechanisms by which data elements can be passed across the interface of a workflow component.
- **Data-based routing** — which characterise the manner in which data elements can influence the operation of other aspects of the workflow, particularly the control flow perspective.

In this section, an analysis of UML version 2.0 AD is presented in the context of the data patterns as described in [11].

4.1 Data visibility patterns

Data visibility patterns seek to characterise the various ways in which data elements can be defined and utilised within the context of a workflow engine. In general, this is determined by the main construct to which the data element is bound as this implies a particular scope in which the data element is visible and capable of being utilised.

There are eight patterns which relate to data visibility:

- Task data (pattern 1) – where data elements are defined by tasks and are only accessible in the context of individual execution instances of the task.
- Block data (pattern 2) – where data elements are defined by block tasks (i.e. tasks which can be described in terms of a corresponding sub-workflow decomposition) such that they are accessible to all of the components within the sub-workflow.
- Scope data (pattern 3) – where data elements can be defined and bound to a subset of the tasks in a process definition.
- Folder data (pattern 4) – where data elements can be defined and bound to a subset of the tasks in a process definition but are accessible to all instances of those tasks regardless of the case to which they correspond.
- Multiple instance data (pattern 5) – where data elements can be defined which are specific to a single execution instance of a task (where the task is able to be executed multiple times).
- Case data (pattern 6) – where data elements can be defined which are specific to a process instance or case of a workflow. They can be accessed by all components of the workflow during the execution of the case.
- Workflow data (pattern 7) – where data elements can be defined in such a way that they are accessible to all components in all cases.
- Environment data (pattern 8) – which describes the situation where data elements defined in the operational environment in which the workflow is sited can be accessed within the workflow system.

In the case of UML 2.0 AD, there is support for several of these patterns. The smallest operational unit in the context of these diagrams is the action. These correspond to the notion of a workflow task and although the notion of task data is not directly supported, there is indirect support in the situation where a local action language is utilised which provides action-specific variables (see [9], p. 282-3).

Activities serve as the main grouping mechanism in UML 2.0 AD and they have similar characteristics to the block construct in workflow process definitions. The block data pattern is directly supported through parameters to activities (see [9], p. 304) which are accessible to all activity components. The concept of attributes (see [9], p. 289) is also provided which allows data elements to be defined which are scoped to a specific activity.

Scope data and folder data are not supported. The ActivityGroup construct (see [9], p. 301) seems to offer something analogous however the semantics of the construct are not defined.

Multiple instance data is directly provided for. There are three situations where multiple instances of a given task may arise:

1. Where a task is specifically designated as having multiple instances in the process model – this facility seems to be provided by the ExpansionKind construct (see [9], p. 324) where the parallel option is chosen forcing parallel execution.
2. Where a task can be triggered multiple times e.g. it is part of a loop. This situation is allowable in UML 2.0 AD (see [9], p. 287).
3. Where two tasks share the same decomposition. This is also supported in UML 2.0 AD as each activity decomposition is distinct as it has a different set of tokens supplied to it at initiation (see [9], p. 302).

Case data is not supported as there does not appear to be a notion of distinct execution instances in UML 2.0 AD, rather all instances of a process model execution in the some context are differentiated by distinct sets of control and object tokens flowing through the diagram.

Workflow data is directly supported through data objects or ObjectNodes (see [9], p. 349) which are potentially accessible to all of the components in a UML 2.0 AD.

There does not appear to be the ability within a UML 2.0 AD to refer to data outside of the context of the diagram, and hence environment data is not supported.

4.2 Internal data interaction patterns

Internal data interaction patterns deal with the various ways in which data elements can be passed between components within a workflow process and how the characteristics of the individual components can influence the manner in which the trafficking of data elements occurs. There are six scenarios in which this may occur:

- Data elements flowing between task instances (pattern 9).
- Data elements flowing from a block task to its decomposition or vice versa (patterns 10-11).
- Data elements flowing to or from a multiple instance task instance (patterns 12-13).
- Data elements flowing between cases (pattern 14).

Data interaction between tasks is directly supported in UML 2.0 AD by the ObjectNode construct (see [9], p. 345) which is the standard means of communicating data elements between activities.

Data interaction between block tasks and their decompositions has a similar analogy in UML 2.0 AD in the form of data passing to and from activities. The standard means of doing this is via parameters (see [9], p. 304). Both the Data interaction block task to sub-workflow and data interaction sub-workflow to block task patterns are directly supported.

Data interaction to and from multiple instance tasks has a direct analogy in UML 2.0 AD in the ExpansionRegion construct (see [9], p. 325) which allows nominated regions of a process model to be executed multiple times in parallel (providing the ExpansionKind mode is set to parallel). Data passing into and out of the ExpansionRegion occurs using ExpansionNodes which provide the ability to map distinct sections of the input data set to specific execution instances and similarly completing instances can map their output to a specific section of the output data set. Hence the Data interaction to and from multiple instance task patterns (12 and 13) are directly supported.

There is no notion of distinct execution cases in UML 2.0 ADs, hence the Data interaction – case to case pattern (14) is not supported.

4.3 External data interaction patterns

External data interaction patterns identify situations where data passing occurs between the workflow and the operating environment. They may involve data transfer between a component of the workflow and an application, data store or interface that is external to the workflow.

There are 12 external data interaction patterns, characterised by three dimensions:

- The type of workflow component – task, case or workflow – that is interacting with the environment.
- Whether the interaction is push or pull-based
- Whether the interaction is initiated by the workflow component or the environment.

Difficulties arise when examining UML 2.0 ADs in the context of this class of patterns as the UML approach assumes the Activity Diagram represents the complete universe of discourse and does not provide the ability to reference or interact with elements that are external to it.

4.4 Data transfer patterns

Data transfer patterns focus on the manner in which the actual transfer of data elements occurs between one workflow component and another. They aim to capture the various mechanisms by which data elements can be passed across the interface of a workflow component.

There are seven distinct patterns in this category:

- Data transfer by value – incoming (pattern 27) – where incoming data elements to a workflow component are passed by value.
- Data transfer by value – outgoing (pattern 28) – where outgoing data elements from a workflow component are passed by value.
- Data transfer – copy in/copy out (pattern 29) – where a workflow component copies the values of data elements into its address space from some external source at commencement and copies them back to that source once it has completed execution.
- Data transfer by reference – without lock (pattern 30) – where data elements are communicated between workflow components by utilising a reference to the location of the data element in some mutually accessible location. No concurrency restrictions apply to the shared data element.
- Data transfer by reference – with lock (pattern 31) – is similar to pattern 30 except that concurrency restrictions are implied with the receiving component receiving the privilege of read-only or dedicated access to the data element.
- Data transformation – input (pattern 32) – where a transformation function is applied to a data element prior to it being passed to a workflow component.
- Data transformation – output (pattern 33) – where a transformation function is applied to a data element prior to it being passed from a workflow component.

In the context of UML 2.0 ADs, only three of these patterns are supported:

- Data transfer by reference – with lock is the standard means of passing data elements into an activity as parameters. Because UML 2.0 ADs adopt a token-oriented approach to data passing, these parameters – which typically relate to objects – are effectively consumed at activity commencement and only become visible and accessible to other activities once the specific activity to which they were passed has completed and returned them.
- Data transformation – both input and output – can be achieved through the ObjectFlow transformation behaviour (see [9], p. 345) which allows transformation functions to be applied to data tokens as they are passed along connecting edges between activities.

4.5 Data-based routing patterns

Data-based routing patterns capture the various ways in which data elements can interact with other perspectives and influence the overall operation of the workflow.

There are seven patterns in this category:

- Task precondition – data existence (pattern 34) – where data-based preconditions can be specified for tasks based on the presence of data elements at execution time.
- Task precondition – data value (pattern 35) – where data-based preconditions can be specified for tasks based on the value of specific data elements at execution time.
- Task postcondition – data existence (pattern 36) – where data-based postconditions can be specified for tasks based on the existence of data elements at execution time.
- Task postcondition – data value (pattern 37) – where data-based postconditions can be specified for tasks based on the value of specific data elements at execution time.
- Event-based task trigger (pattern 38) – the ability for an external event to initiate a task.
- Data-based task trigger (pattern 39) – the ability to trigger a specific task when an expression based on workflow data elements evaluates to true.
- Data-based routing (pattern 40) – the ability to alter the control flow within a workflow case as a consequence of the value of data-based expressions.

The majority of these patterns are supported in UML 2.0 ADs. Both action and activity constructs include local preconditions and postconditions based on logical expressions (which may include data elements) framed in OCL (see [9], p. 280 and 305). As a consequence, all of the task pre and postcondition patterns (34 - 37) are directly supported.

The `AcceptEventAction` construct (see [9], p. 217) provides direct support for the event-based task triggering pattern. Similarly, there is also direct support for data-based routing via the `DecisionNode` construct and guard conditions on `ActivityEdges` (see [9], p. 319 and 293). Data-based task triggers are not directly implemented, however a similar (although somewhat more limited effect) can also be achieved through guards on `ActivityEdges`.

5 Conclusion

Table 1 summarises the evaluation in terms of the control flow patterns. A '+' in the table indicates *direct support* for the pattern (i.e. there is a construct in the language that directly supports the pattern). The evaluation of UML 2.0 is contrasted with a previous evaluation of UML 1.4⁷. Overall, UML 2.0 is a clear improvement over UML 1.4 in terms of *direct support* for the control flow patterns. As regards the patterns that UML 2.0 does not directly support we would like to make the following recommendations:

- Given the difficulties in supporting state-based patterns, most notably the interleaved parallel routing pattern and the milestone pattern, it may be worthwhile to provide direct support for the notion of place as it exists in Petri nets. Petri net places capture the notion of “waiting state” in a much less restrictive way than “receive signal actions” do. Similarly to YAWL, one could then choose to allow for implicit places to avoid that places unnecessarily clutter up the diagram.

⁷ This evaluation is based on [5] and the table presented at www.workflowpatterns.com.

- UML AD currently does not support the creation of new instances of an activity while other instances of that activity are already running. This could be resolved through extensions to the “expansion region” construct along the lines of the “multiple instance” tasks in YAWL.
- Given the lack of support for the OR-join, a concept similar to the OR-join as it exists in YAWL could be added to UML AD.

Nr	Pattern	2.0	1.4	Nr	Pattern	2.0	1.4
1	Sequence	+	+	11	Implicit Termination	+	–
2	Parallel Split	+	+	12	MI without Synchronization	+	–
3	Synchronization	+	+	13	MI with a priori Design Time Knowledge	+	+
4	Exclusive Choice	+	+	14	MI with a priori Runtime Knowledge	+	+
5	Simple Merge	+	+	15	MI without a priori Runtime Knowledge	–	–
6	Multi Choice	+	–	16	Deferred Choice	+	+
7	Synchronizing Merge	–	–	17	Interleaved Parallel Routing	–	–
8	Multi-Merge	+	–	18	Milestone	–	–
9	Discriminator	+	–	19	Cancel Activity	+	+
10	Arbitrary Cycles	+	–	20	Cancel Case	+	+

Table 1. Comparison of UML AD (version 2.0) and UML AD (version 1.4)

The data patterns evaluation is summarised in Table 5. The evaluation shows that the control-flow and the data perspectives are well integrated. Pre/postconditions, triggers and routing are all supported. Furthermore, the following remarks can be made:

- There is no notion of cases in UML 2.0 ADs hence all data is effectively block-scoped by default and parallel threads of execution occur in the same data space. This could lead to some interesting situations when modelling highly data intensive and/or highly concurrent processes.
- The use of “tokens” as the fundamental underpinning for control and data flow introduces some subtle variations that do not exist in workflow systems (except those based on Petri-nets) - in particular data elements are truly consumed (and cease to exist) when they are passed to an activity for the duration of the activity. This also makes it difficult to actually share a data element/object between concurrent activities. On the other hand, it minimises concurrency problems.
- The token approach provides an effective basis for internal data interaction (and hence all patterns are “+”). In particular, multiple instance data handling seems to be supported for all three multiple instance situations: designated MI tasks, multiply triggered tasks (loops) and block tasks with a common decomposition.
- There does not seem to be any ability to model things “outside of the model” i.e. in the external environment. Hence there is no real ability to support external data interaction patterns. This may be addressed by using UML AD in conjunction with other diagrams such as UML interaction overview and sequence diagrams, but then, the relationships between these diagrams need to be carefully established.

Nr	Pattern		Nr	Pattern	
	Data Visibility			External Data Interaction	
1	Task Data	+/-	21	Environment to Case – Push-Oriented	-
2	Block Data	+	22	Case to Environment – Pull-Oriented	-
3	Scope Data	-	23	Workflow to Environment – Push-Oriented	-
4	Folder Data	-	24	Environment to Workflow – Pull-Oriented	-
5	Multiple Instance Data	+	25	Environment to Workflow – Push-Oriented	-
6	Case Data	-	26	Workflow to Environment – Pull-Oriented	-
7	Workflow Data	+		Data Transfer	
8	Environment Data	-	27	by Value – Incoming	-
	Internal Data Interaction		28	by Value – Outgoing	-
9	between Tasks	+	29	Copy In/Copy Out	-
10	Block Task to Sub-workflow Decompos.	+	30	by Reference – Unlocked	-
11	Sub-workflow Decompos. to Block Task	+	31	by Reference – Locked	+
12	to Multiple Instance Task	+	32	Data Transformation – Input	+
13	from Multiple Instance Task	+	33	Data Transformation – Output	+
14	Case to Case	-		Data-based Routing	
	External Data Interaction		34	Task Precondition – Data Existence	+
15	Task to Environment – Push-Oriented	-	35	Task Precondition – Data Value	+
16	Environment to Task – Pull-Oriented	-	36	Task Postcondition – Data Existence	+
17	Environment to Task – Push-Oriented	-	37	Task Postcondition – Data Value	+
18	Task to Environment – Pull-Oriented	-	38	Event-based Task Trigger	+
19	Case to Environment – Push-Oriented	-	39	Data-based Task Trigger	+/-
20	Environment to Case – Pull-Oriented	-	40	Data-based Routing	+

Table 2. Support for Data Routing Patterns in UML 2.0 ADs

During this pattern-based analysis, we had to face several ambiguities in the current UML specification. Unfortunately, the UML AD notation is not yet formalised although work in this direction is ongoing (see e.g. [7]). It is hoped that this paper may contribute to advancing these efforts. There are inherent difficulties in assessing a language that does not have a commonly agreed upon formal semantics nor an execution environment.

Acknowledgements

This work was partially supported by the Dutch research school BETA and the Australian Research Council under the Discovery Grant “Expressiveness Comparison and Interchange Facilitation between Business Process Execution Languages”.

References

1. W.M.P. van der Aalst, L. Aldred, M. Dumas, and A.H.M. ter Hofstede. Design and Implementation of the YAWL System. In *Proceedings of the 16th International Conference on Advanced Information Systems Engineering (CAISE'04)*, volume 3084 of *Lecture Notes in Computer Science*, pages 142–159. Springer Verlag, 2004.

2. W.M.P. van der Aalst and A.H.M. ter Hofstede. YAWL: Yet Another Workflow Language. Accepted for publication in *Information Systems*, and also available as QUT Technical report FIT-TR-2003-04, Queensland University of Technology, Brisbane, Australia, 2003.
3. W.M.P. van der Aalst, A.H.M. ter Hofstede, B. Kiepuszewski, and A.P. Barros. Workflow Patterns. *Distributed and Parallel Databases*, 14(1):5–51, 2003.
4. F. Casati, S. Ceri, B. Pernici, and G. Pozzi. Conceptual Modelling of Workflows. In M.P. Papazoglou, editor, *Proceedings of the 14th International Object-Oriented and Entity-Relationship Modelling Conference (OOER)*, volume 1021 of *Lecture Notes in Computer Science*, pages 341–354, Gold Coast, Australia, December 1998. Springer.
5. M. Dumas and A. ter Hofstede. UML activity diagrams as a workflow specification language. In M. Gogolla and C. Kobryn, editors, *Proc. of the 4th Int. Conf. on the Unified Modeling Language (UML01)*, volume 2185 of *Lecture Notes in Computer Science*, pages 76–90. Springer Verlag, Oct 01.
6. P. Green and M. Rosemann. Applying Ontologies to Business and Systems Modeling Techniques and Perspectives: Lessons Learned. *Journal of Database Management*, 15(2):105–117, 2004.
7. H. Störrle. Semantics of Control-Flow in UML 2.0 Activities. In *IEEE Symposium on Visual Languages and Human-Centric Computing (VL/HCC'04)*, pages 235–242, September 2004.
8. Ja-Hee Kim and C. Huemer. Analysis, Transformation, and Improvements of ebXML Choreographies Based on Workflow Patterns. In *Proceedings of the OTM Confederated International Conferences (CoopIS, DOA, and ODBASE)*, volume 3290–3291 of *Lecture Notes in Computer Science*, pages 66–84, Agia Napa, Cyprus, October 2004.
9. OMG. UML 2.0 Superstructure Specification. OMG Draft Adopted Specification, ptc/03-08-02, August 2003. <http://www.omg.org/cgi-bin/doc?ptc/2003-08-02>.
10. A.L. Opdahl and B. Henderson-Sellers. Ontological Evaluation of the UML Using the Bunge-Wand-Weber Model. *Software and System Modeling*, 1(1):43–67, 2002.
11. N. Russell, A.H.M. ter Hofstede, D. Edmond, and W.M.P. van der Aalst. Workflow Data Patterns. QUT Technical report, FIT-TR-2004-01, Queensland University of Technology, Brisbane, Australia, 2004.
12. WfMC. Workflow Management Coalition Terminology & Glossary, Document Number WFMC-TC-1011, Document Status - Issue 3.0. Technical report, Workflow Management Coalition, Brussels, Belgium, February 1999.
13. S. White. Process Modeling Notations and Workflow Patterns. In L. Fischer, editor, *Workflow Handbook 2004*, pages 265–294. Future Strategies Inc., Lighthouse Point, FL, USA, 2004.
14. P. Wohed, W.M.P. van der Aalst, M. Dumas, and A.H.M. ter Hofstede. Analysis of Web Services Composition Languages: The Case of BPEL4WS. In *22nd International Conference on Conceptual Modeling (ER 2003)*, volume 2813 of *Lecture Notes in Computer Science*, pages 200–215. Springer Verlag, 2003.
15. M.T. Wynn, D. Edmond, A.H.M. ter Hofstede, and W.M.P. van der Aalst. Achieving a General, Formal and Decidable Approach to the OR-join in Workflow using Reset nets. QUT Technical report, FIT-TR-2004-02, Queensland University of Technology, Brisbane, Australia, 2004.