

## EJECTOR APPLICATIONS IN REFRIGERATION AND HEATING: AN OVERVIEW OF MODELING, OPERATION AND RECENT DEVELOPMENTS

*Zine Aidoun, Daniel Giguère, David A. Scott, Sophie Hosatte, CanmetENERGY, Natural Resources Canada, 1615 boul. Lionel-Boulet, CP 4800, Varennes, Québec, J3X 1S6, Canada  
shosatte@nrcan.gc.ca*

*This paper was published in the proceedings of the 10<sup>th</sup> International Heat Pump Conference 2011 ([www.heatpumpcentre.org/en/hppactivities/ieaheatpumpconference](http://www.heatpumpcentre.org/en/hppactivities/ieaheatpumpconference)).*

**Abstract:** The utilization of ejectors in heat pump systems as compression components, alone or in combination with other equipment, have gained renewed interest as a thermally driven solution for low temperature heat recovery and upgrading and more efficient energy use. This paper summarizes the main findings and trends, in the area of heat driven ejector based machines using low boiling point working fluids. An overall view of such systems is provided by presenting the ejector principles of physics and the latest developments on ejector design, operation and modeling approaches. Aspects related to the analysis of the complex interacting phenomena taking place in these systems for high performance are highlighted. Conventional and improved ejector heat pump cycles of interest employing ejectors alone or boosted combinations are presented and discussed, and their potential applications are indicated. Finally, sample theoretical and experimental results obtained at CanmetENERGY on ejector operation and design are reported.

**Key Words:** ejector modelling, design, simulation, experiments, thermal activation, cycle

### 1 INTRODUCTION

An ejector is a form of thermally activated jet-pump that is generally used for pumping gases from systems to produce vacuum or compressing vapours. They have been in application for many years (ASHRAE 1969), but mainly restricted to industrial applications using steam as the working fluid. They are commercially available in different sizes and geometries to match different power requirements. The ejector as a component is simple, low cost, and without moving parts, which makes it attractive for many applications. However, the fundamental mechanisms involved during their operation are complex due to the interactions during mixing of two fluid streams in sub-sonic and super-sonic conditions.

The utilization of ejectors for heat pump applications (heat upgrading, cooling and refrigeration) has been limited until now because of the lack of knowledge on their performance over a wide range of operating conditions and using different refrigerants, and also because of their low energy efficiency compared to mechanical vapour compression systems. However, in the current energy and environmental context, there is a renewal of interest for ejectors as a thermally driven technology which may provide a reliable and low-cost solution for recovering and upgrading thermal energy.

As a thermally driven heat pumping technology, ejectors may be considered in many applications. For heating and cooling in buildings, houses and communities, ejectors may be used in combination with renewable energy systems or distributed generation systems in tri-generation applications. In industry, they represent an attractive solution for waste heat

upgrading. They may be used as a stand-alone system or in hybrid vapour compression-ejector or absorption-ejector systems.

The availability of more sophisticated modeling tools (e.g. Computational Fluid Dynamics) combined with experimental analysis, provides new opportunities to develop advanced knowledge on the internal phenomena occurring in the ejector, to identify solutions that reduce internal losses, to optimize ejector performance by varying design, geometry, and refrigerants and to evaluate the performance of innovative cycles based on a combination of ejectors with vapour compression or absorption systems for different applications.

This paper presents the principles of ejectors, different application cycles, performance obtained through modelling and experimental work, and a discussion on some promising applications for ejectors.

## 2 EJECTOR OPERATION

Basic ejector operation is briefly described here but a more detailed account can be found in journal publications (Ouzzane and Aidoun 2003). The principle of operation of all supersonic ejectors is the same, regardless of the application. As shown in Figure 1, a high energy refrigerant stream is expanded in a primary nozzle (1), converting pressure and temperature to velocity.

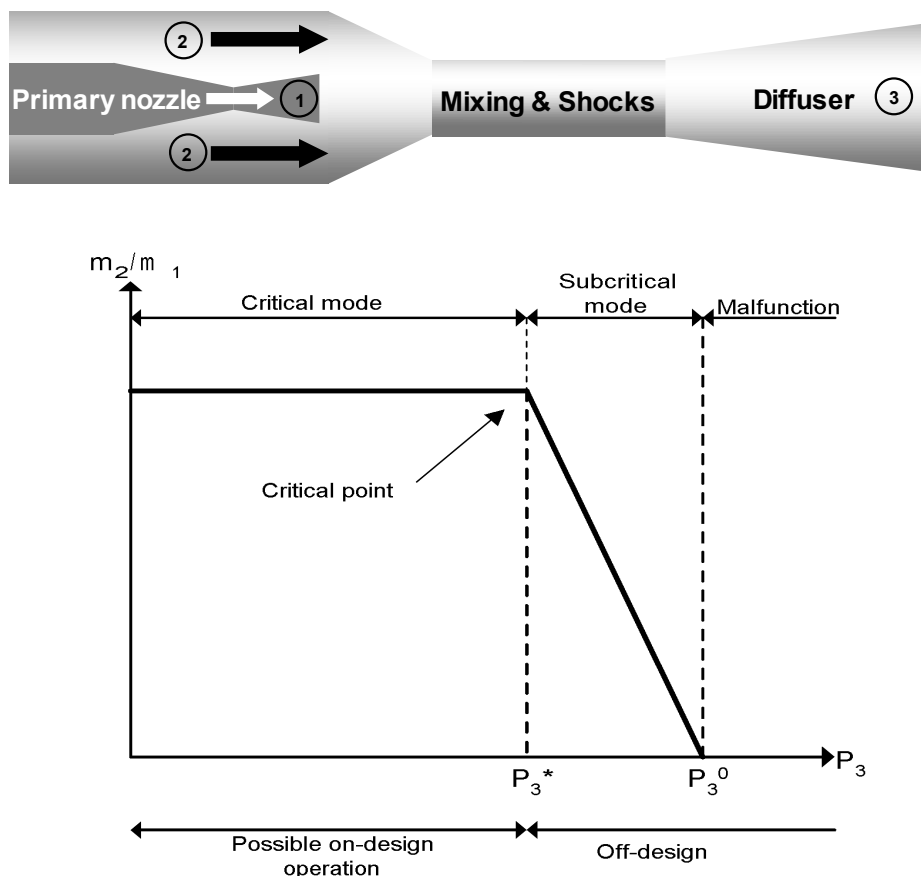

**Figure 1: Ejector operation**

At the nozzle exit, the flow is supersonic with low temperature and pressure. This induces the flow of a low energy stream (2) from the evaporator, through a secondary nozzle at the exit

of which sonic conditions are reached (design point). The main characteristic of the performance curve shown in Figure 1 is that the entrainment ratio  $m_2/m_1$  remains constant up to a threshold (design point) before dropping rapidly (off design operation zone). Energy exchange between streams occurs in the mixing chamber but high mixing losses, friction, shock formation etc., are also expected because of the streams very different conditions. The flow leaving the mixing chamber becomes subsonic as a result of all the losses and shocks. It then enters a diffuser where it is further compressed (3).

### 3 PREVIOUS RESEARCH ON EJECTORS

Current needs for efficient and environmentally sound heating, air conditioning and refrigeration systems have revived research interests in order to improve ejector performance and competitiveness. Experimental and theoretical work has been extensively performed on ejector operation for some decades and it is currently continuing but despite the apparent simplicity of the ejector geometry, there is still no comprehensive theory capable of completely describing its working mechanisms and ejector modeling remains a problem not yet completely resolved. Available literature, some going back to very early years, contributes however to a better understanding of ejector design and operation.

#### 3.1 One-dimensional approach

Earlier theoretical and experimental work using gases and vapours was based on the one-dimensional theory developed by Keenan and his collaborators. Two design methods emerged out of these efforts, due to Keenan & Newman (1946) and Keenan et al. (1950), who proposed 1-D models with constant area and with constant pressure mixing respectively, but ignoring heat and friction losses. They first introduced the constant-area-mixing principle (1946) and performed their mathematical development by assuming that the working fluid behaved like an ideal gas. This approach considers a constant cross-sectional area for the entire mixing chamber (Figure 2).

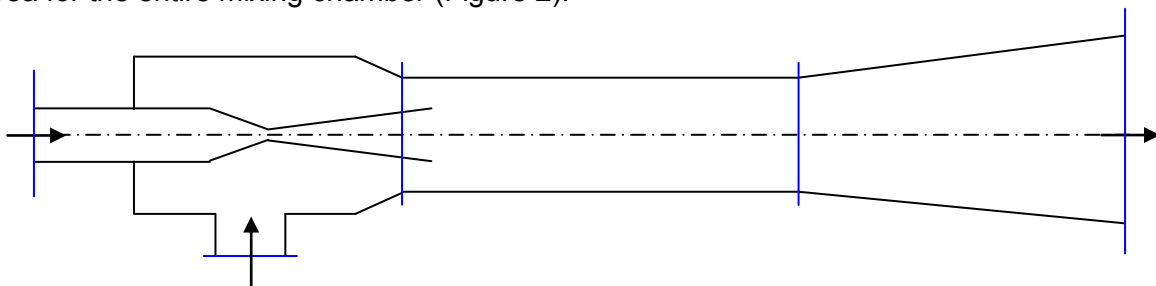

**Figure 2: Constant area ejector**

The concept of constant pressure design was subsequently introduced (1950). This principle is the most frequently used nowadays for its better performance and more favourable comparison against experimental data. The geometry of a constant pressure design includes a variable cross section zone immediately before the constant cross section part, with the nozzle exit located within this zone (Figure 3).

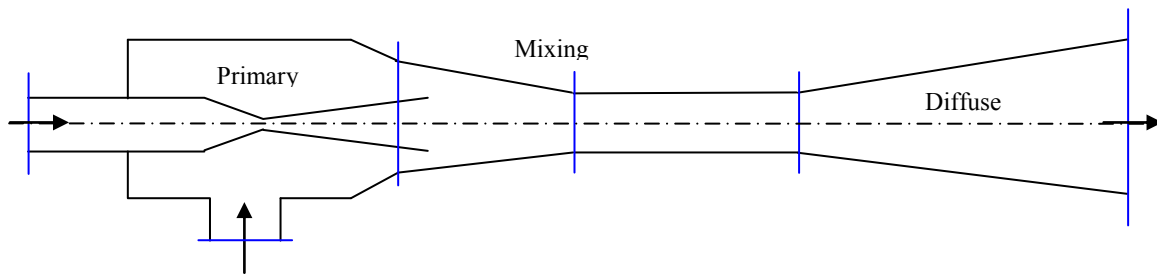

**Figure 3: Constant pressure ejector**

In 1977, Munday and Bagster proposed a semi-empirical approach in an attempt to explain the constant capacity characteristics of ejectors represented in Figure 1. This approach introduces a new concept by assuming that two discrete streams, the primary and secondary flows, maintain their identity up to a certain distance down the mixing chamber. Accordingly, the primary stream fans out into the mixing chamber without mixing with the entrained flow, forms with the internal walls of the chamber a converging channel that acts as a nozzle for the secondary stream and eventually creates a low pressure region in the mixing section. The secondary fluid accelerates to sonic velocity without mixing with the primary stream. The location of the point where critical conditions occur is the effective throat of the secondary nozzle beyond which stream mixing at constant pressure begins. Downstream of the mixing section, a normal shock is induced, causing a sudden increase of pressure and a simultaneous decrease of the flow Mach number. According to this concept, it is assumed that the shock wave occurs at the end of the constant area section. In the mixing process, the flow transits from supersonic to subsonic. The diffuser compresses the flow further as it is brought to a stagnation state.

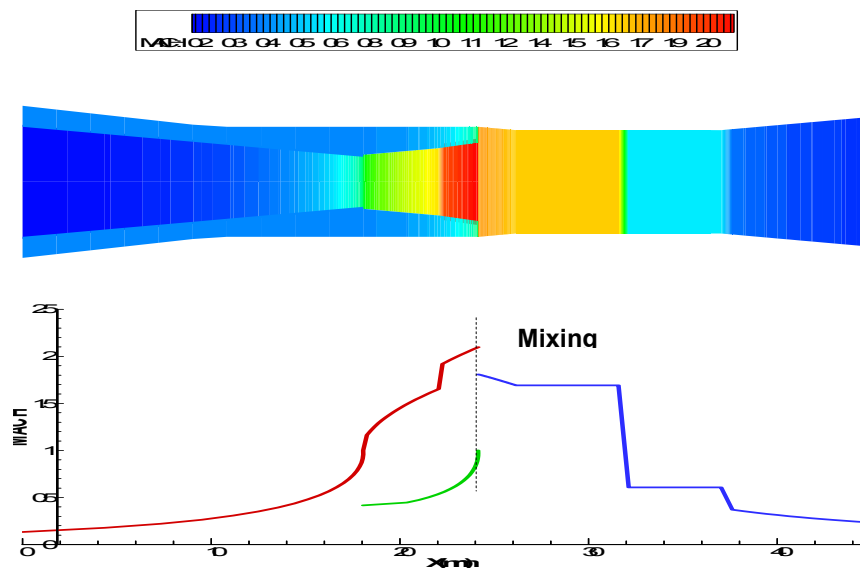

**Figure 4: Mach distribution in the ejector (1-D)**

Subsequent work was essentially based on these theories and, recognising the effects of parameters such as internal geometry, mixing-shocks interactions and refrigerant effects, researchers have progressively lifted many of the restrictive assumptions made in the previous theories. Huang et al. (1999), for example, used Munday and Bagster's approach with R141b and accounted for frictional and mixing losses by means of empirical coefficients which were later confirmed experimentally. Aidoun and Ouzzane (2004), inspired by the Munday and Bagster approach, took into account the change in refrigerant properties within

the flow with axial position in order to more accurately represent the operation of an ejector and estimate the ejector characteristic parameters locally (Figure 4). An extensive and more detailed account of these developments over the last few decades can be found in Ablwaifa (2006).

### **3.2 CFD approach**

The amount of theoretical and experimental work devoted to providing simple analysis and design tools has been and continues to be very useful in promoting the general understanding of ejectors. There is however a serious limitation to its capability in correctly reproducing the flow physics locally along the ejector. It is the understanding of local interactions between shock waves and boundary layers, and their influence on mixing and recompression rates, that will allow minimizing internal losses based on optimized design in terms of geometry, refrigerants and operating conditions. Such an objective can be achieved at a reasonable cost through the use of CFD. Studies with some fluids commonly used in refrigeration or having such a potential were performed, (Chen et al. 1994; Desevaux et al. 1994; Riffat et al. 1996; Wang and Chen 1996; Riffat and Everitt 1999; Riffat and Omer 2001), being a representative sample. However, some very fundamental problems were yet to be overcome, especially the modeling of shock-mixing layer interaction or ejector operation at different conditions. Indeed, some of them did not consider compressibility, turbulence, nor did they track shocks. Desevaux et al. did obtain some local pressure measurements which compared reasonably well with simulations using the Fluent CFD package. These data were also used by Bartosiewicz et al. (2005, 2006) to validate their modeling of ejectors for refrigeration where the influence of turbulence, shock reflections and shock-mixing layer interaction were assessed. The work of Ablwaifa (2006), cited previously, included CFD analysis and validation data in terms of global performance parameters.

### **3.3 Ejector cycles and applications**

Ejector driven heat pump systems have a large potential for using energy sources at low temperature. The simplest configuration of an ejector heat pump cycle is represented in Figure 5. The utilization of working fluids more volatile than water makes it possible to extend the range of applications, which are currently unexploited. For example in the industrial sector where low grade thermal energy is wasted, ejectors offer a potential to use it for cooling or refrigeration, increasing process efficiencies. They are also considered in combination with distributed generation systems to manage excess heat for cooling or refrigeration in tri-generation systems. Combinations of ejectors with other cycles to form hybrid systems (solar collectors, absorption or mechanical compression) provide a considerable potential for cycle optimization and performance enhancement. As a result, ejector-compressor, ejector-absorption and ejector-solar collector cycles continue to receive increased attention in view of their positive impact on performance in exchange for relatively minor modifications to the overall system.

#### **3.3.1 Compressor-assisted ejector**

The work of Sokolov & Hershhal (1990, 1991), Sun and Eames (1995), Dorantes et al. (1996), Sun (1997) and those of Huang et al. (1998) are worth mentioning. Sokolov and his collaborators demonstrated that performance comparable to those of absorption systems could be attained with booster assisted ejector systems running on low grade heat. Depending on the particular operating conditions and cycle configurations, COP improvements reported ranged from 5 % to 40% over conventional cycles.

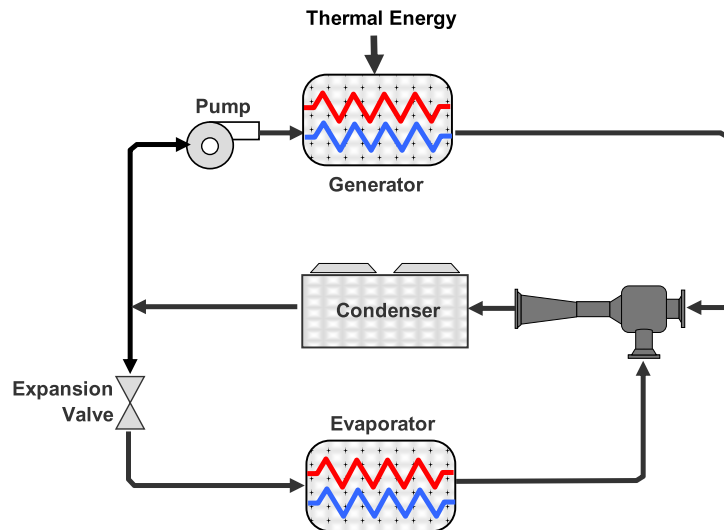

**Figure 5: Schematic drawing of the simplest configuration of a supersonic ejector cycle**

Ejector – Expander

Ejectors may be used inside vapour compression cycles for heating, cooling or refrigeration applications, to reduce the compressor work. In this configuration (Figure 6), the ejector plays the role of the low temperature stage of a two-stage compression cycle to some extent. It is introduced instead of the expansion valve. Its role is to reduce the compression ratio and increase the cycle COP from 10 to 15%. The ejector is driven by the high temperature liquid refrigerant coming out of the condenser.

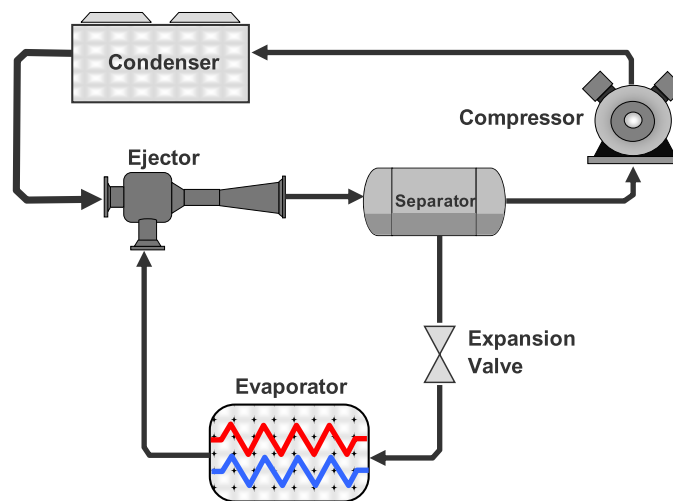

**Figure 6: Schematic drawing of a compressor-assisted ejector cycle**

Ejector for pressure lift increase

Another interesting application is the utilization of the ejector at the compressor outlet for reducing compression ratio and work. As shown in Figures 7 (external energy input) and 8 (without external energy input), the discharge pressure is reduced further to the addition of an ejector that provides a compression stage. The ejector plays the role of the high stage of a two-stage compression cycle. With this system, COP cycle improvements have been evaluated at 30 to 40%.

The configuration presented in Figure 7 requires additional thermal energy to drive the ejector and increasing the size of the condenser as, in this case, it must reject the heat of the generator and of the vapour compression cycle.

In the configuration presented in Figure 8, also known as Condensing ejector, the ejector is driven by the condensate but prior to being sent to the ejector its pressure is raised by a pump so that the ejector can draw vapour refrigerant from the compressor. The challenge is to have the refrigerant condensed in the ejector. The condenser is replaced by a heat exchanger (fluid cooler).

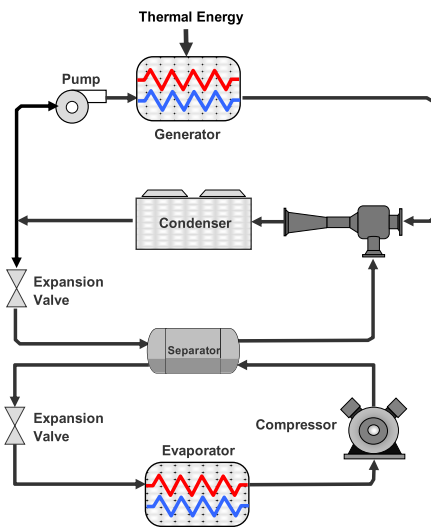

Figure 7: Ejector for pressure lift increase

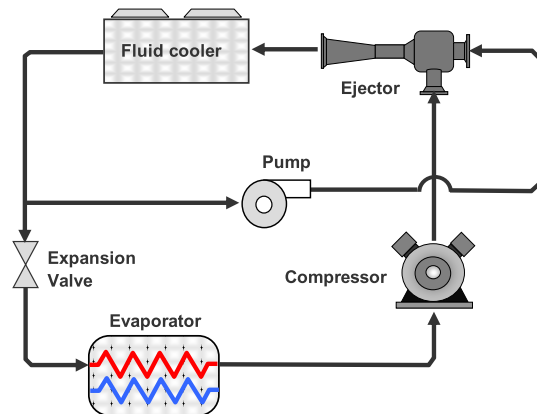

Figure 8: Condensing ejector

In the two cases above, Ejector-expander and condensing ejector, the ejector works in two-phase mode (two-phase flow).

### 3.3.2 Other applications

#### Ejector-enhanced absorption

The application of ejectors in absorption cycles is another area for which substantial improvement in COP is expected by enhancing evaporation, absorption and concentration processes and by carefully selecting the refrigerant. Several studies were conducted on absorption cycles integrating the use of ejectors. The works of Chung et al (1984), Chen (1988), Sun et al. (1996) and Aphornratana et al. (1998) are well documented.

#### Solar activated ejectors

Fluid temperatures provided by thermal solar collectors are appropriate to be exploited to drive ejectors for cooling, refrigeration or heat pumping. Considerable analytical and experimental effort was invested by many researchers to investigate the implementation of solar energy to drive ejector based cycles (Sokolov 1993, Huang 1998, Alexis and Karaiyannis 2005).

#### Compressor superheat activated ejector

In many instances superheat at the compressor discharge is considerable. Huang et al. (2001) analyzed the effect of its recovery to activate an ejector in order to subcool the refrigerant condensate. Refrigerant subcooling is a common practice in refrigeration installations, in order to increase performance. As a result, refrigeration performance increases between 9% and 24% in terms of COP.

## 4 RESEARCH HIGHLIGHTS AT CanmetENERGY

Ejector research performed at CanmetENERGY includes numerical modeling and experimental investigations.

### 4.1 Modeling and simulation

One-dimensional and detailed computational fluid dynamics (CFD) models were developed. Validation was performed, using data from the literature, collaborative exchanges and results from an experimental test bench that was designed and built for this purpose. Results from CFD models provide detailed images of parameter distributions throughout the ejector, allowing users to “see” inside the walls and to identify problem areas such as zones with recirculation and flow separation. Figure 9, based on the simulations of Scott et al. (2008), shows some generic results from one-dimensional CFD models. The single curve showing the variation of the entrainment ratio with ejector exit pressure may be generated by a one-dimensional model. The same curve may be generated by a CFD model, however the results of the CFD model also permit “snapshots” of the flow inside the ejector to be taken, these snapshots showing the variation of the velocity profile inside the ejector at the given operating conditions.

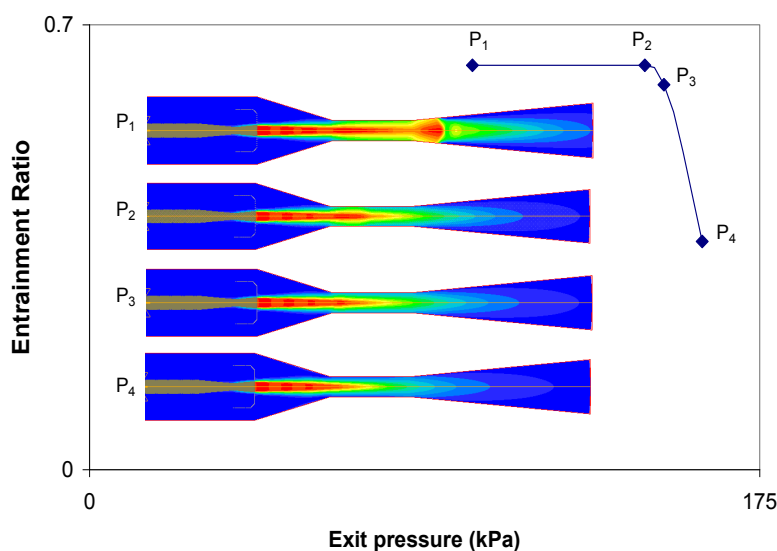

Figure 9: Typical CFD and 1-D ejector simulation results

### 4.2 Experimental Research

A well instrumented experimental test bench was designed and assembled at CanmetENERGY. While the primary purpose of the set-up is to generate data for the validation of the numerical models, it also provides information on start-up and shut-down procedures, performances, as well as general operation. Only a brief description of the test bench is given here; details can be found in Scott et al. (2009). The configuration of the simplest one-phase ejector cycle is shown in Figure 5. The working fluid is R245fa, an HFC that has been shown to have appropriate properties for ejector operation. Ejector capacities up to 9 kW can be tested on this installation. Typical experimental results showing the variation of the entrainment ratio with condenser pressure is shown in Figure 10, with fixed generator and evaporator conditions. The constant entrainment ratio that exists at pressures below the critical condenser pressure is clearly shown, as is the rapid decrease in entrainment ratio above this critical pressure. These and other such results from the test bench were used to validate the numerical models.



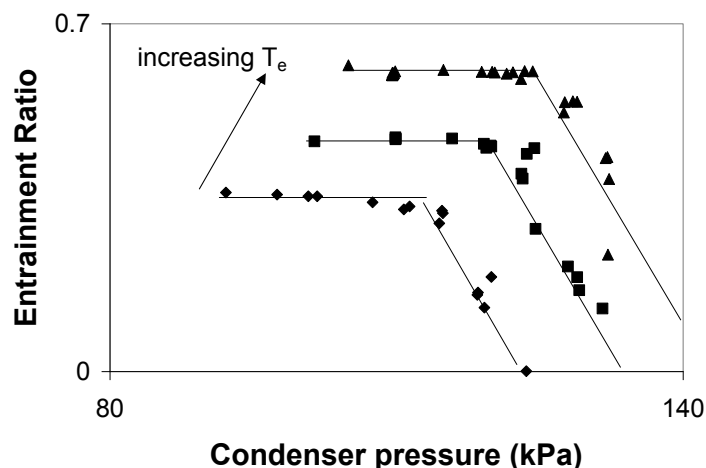

Figure 10: Variation of the entrainment ratio with condenser pressure.

Further R&D activities in ejectors are on-going, particularly on two-phase flow ejectors, using modeling-simulation and experimental work, evaluation of solar assisted ejector cycles for cooling applications, and experimentation of a 30 kW prototype for cooling applications using waste heat.

## 5 CONCLUSION

Ejectors are a unique technology involving simple components but of which the operation, based on the mixing of two fluid streams in sub- super- sonic conditions, is quite complex. This technology is currently unexploited due to the lack of fundamental knowledge on its operation, while it presents interesting opportunities for thermal energy upgrading for heating, cooling or refrigeration applications, and for heat pump cycle improvements in hybrid systems. Other advantages of the technology are the simplicity of the components (nozzles) and their low costs, its compactness, particularly compared to absorption, and its reliability as no moving parts are involved. The most promising applications are waste heat valorization in the industry and combinations with thermal solar energy for buildings.

Ejectors must not be considered as a competitive technology to vapour compression systems, due to their low coefficients of performance and small temperature lifts of the basic cycles. However, the technology must be seriously examined for thermal energy valorization, for heat pump cycle improvements and particularly in hybrid cycles. The benefits are the significant COP increases, the possibility to reduce compressor work, or increase pressure or temperature lift and power, with low cost and reliable additional components.

The development of fundamental knowledge on the mechanisms involved in ejectors in one- or two- phase flow, as well as knowledge on system performance and control as stand alone or hybrid systems are required to better evaluate and design the most judicious applications of ejectors. Investigation of refrigerants and their mixtures is also a promising avenue to expand their range of applications.

## 6 REFERENCES

ASHRAE 1969. Steam-jet refrigeration equipment, Chapter 13, ASHRAE Guide and Data Book.

- Ablwaifa A. 2006. "A Theoretical and Experimental Investigation of Jet-Pump Refrigeration", PhD thesis, Nottingham University, England, UK.
- Aidoun Z., M. Ouzzane 2004. "The effect of operating conditions on the performance of a supersonic ejector for refrigeration", *Int. Journal of Refrigeration*, Vol. 27, pp. 974-984.
- Alexis G., E. Karayiannis 2005. "A solar ejector cooling system using refrigerant R134a in the Athens area", *Renewable Energy*, Vol. 30, pp. 1457-1469.
- Aphnonratana S., I.W. Eames 1998. "Experimental investigation of a combined ejector-absorption refrigerator", *Int. J. of Energy Research*, Vol. 22, pp. 195-207.
- Bartosiewicz Y., Z. Aidoun, P. Desevaux, Y. Mercadier 2005. "Numerical and experimental investigations on supersonic ejectors", *Int. J. Ht. & Fl. Flow*, Vol. 26, pp. 56-70.
- Bartosiewicz Y., Z. Aidoun, Y. Mercadier 2006. "Numerical assessment of ejector operation for refrigeration applications based on CFD". *Appl. Th. Eng.*, Vol. 26, pp. 604-612.
- Chen F., C. Liu, J. Yang 1994. "Supersonic flow in the second-throat ejector-diffuser system", *Journal of Spacecraft and Rockets*, Vol. 31, pp. 123-129.
- Chen L.T. 1988. "A new ejector-absorber cycle to improve COP of an absorption system", *Appl. Energy*, Vol. 30, pp. 1-37.
- Chung H., M.H. Huor, M. Prevost, R. Bugarel 1984. "Domestic heating application of an absorption heat pump. Direct fired heat pumps", *Proc. Int. Conf. Univ. of Bristol*, pp. 19-21.
- Desevaux P., J.P. Prenel, P. Jacquet 1994. "Static Pressure Measurement along the Centerline of an Induced Flow Ejector", *Experiments in Fluids*, Vol. 16, pp. 289-291.
- Dorantes R., C.A. Estrada, I. Pilatowski 1996. "Mathematical simulation of a solar ejector-compression refrigeration system", *ATE*, Vol.16, (8/9), pp. 669-675.
- Huang B., J.M. Chang, V.A. Petrenko, K.B. Zhuk 1998. "A solar ejector cooling system using refrigerant R141b", *Solar Energy*, Vol. 64, Nos 4-6, pp. 223-226.
- Huang B., J.M. Chang, C.P. Wang, V.A. Petrenko 1999. "A 1-D Analysis, of Ejector Performance", *Int. J. of Refrigeration*, Vol. 22, pp. 354-364.
- Huang B., V.A. Petrenko, J.M. Chang, C.P. Lin, S.S. Hu 2001. "A combined-cycle refrigeration system using ejector-cooling cycle as the bottom cycle", *Int. J. of Refrigeration*, Vol. 24, pp. 391-399.
- Keenan J. H., E.P. Newman 1946. "A simple air ejector", *J. Appl. Mech., Trans. ASME*, Vol. 64, pp. A75-A81.
- Keenan J. H., E.P. Newman, F. Lustwerk 1950. "An Investigation of Ejector Design by Analysis and Experiment", *J. Applied Mechanics, Trans. ASME*, 72, pp. 299-309.
- Munday J.T., D.F. Bagster 1977. "A New Ejector Theory Applied to Steam Jet Refrigeration", *Ind. Eng. Chem. Process Res Dev.*, Vol. 16(4), pp. 442-449.
- Ouzzane M., Z. Aidoun 2003. "Model development and numerical procedure for detailed ejector analysis and design", *Applied Thermal Engineering*, Vol. 23, pp. 2337-2351.

Riffat S.B., G. Gan, S. Smith 1996. "Computational fluid dynamics applied to ejector heat pumps", *Applied Thermal Engineering*, Vol. 16, pp. 291-297.

Riffat S.B., P. Everitt 1999. "Experimental and cfd modelling of an ejector system for vehicle air conditioning", *Journal of the Institute of Energy*, Vol. 72, pp. 41-47.

Riffat S.B., S.A. Omer 2001. "CFD modelling and experimental investigation of an ejector refrigeration system using methanol as the working fluid", *Int. J. of Engng. Research*, Vol. 25, pp. 115-128.

Scott, D.A., Z. Aidoun, M. Ouzzane 2009. "An experimental investigation of an ejector operating with R245fa", *Proc. Int. Seminar on ejector/jet-pump technology and applications*, Sept. 7-9, Louvain-la-Neuve, Belgium, Paper No. 21.

Scott D.A., Z. Aidoun, O. Bellache, M. Ouzzane 2008. "CFD simulations of a supersonic ejector for use in refrigeration applications", *Proc. 12<sup>th</sup> Int. Refr. and Air Cond. Conf. at Purdue*, July 14-17, India.

Sokolov M., D. Hershgal 1990. "Enhanced ejector refrigeration cycles powered by low grade heat. Part 1: Systems characterization", *Int. J. of Ref.*, Vol. 13, pp. 351-356.

Sokolov M., D. Hershgal 1990. "Enhanced ejector refrigeration cycles powered by low grade heat. Part 2: Design procedures", *Int. J. of Refrigeration*, Vol. 13, pp. 357-363.

Sokolov M., D. Hershgal 1991. "Enhanced ejector refrigeration cycles powered by low grade heat. Part 3: Experimental results", *Int. J. of Refrigeration*, Vol. 14, pp. 24-31.

Sokolov M., D. Hershgal 1993a. "Optimal coupling and feasibility of solar powered year-round ejector air conditioner", *Solar Energy*, Vol. 50, pp. 507-516.

Sokolov M., D. Hershgal 1993b. "Solar powered compression enhanced ejector air conditioner", *Solar Energy*, Vol. 51, pp. 183-194.

Sun D.W., I.W. Eames 1995. "Recent Development in the Design Theories and Applications of Ejector - a Review", *Journal of the Institute of Energy*, Vol. 68, pp. 65-79.

Sun D., I. Eames, S. Aphornratana 1996. "Evaluation of a novel combined ejector-absorption refrigeration cycle. 1. computer simulation", *Int. J. of Ref.*, Vol. 19 (3), pp. 172-180.

Sun D. 1997. "Solar powered combined ejector-vapour compression cycle for air conditioning and refrigeration", *Energy Convers. Mgmt.*, Vol. 38, No 5, pp. 479-491.

Wang J., F. Chen 1996. "On the start condition of a second throat ejector diffuser", *Aeronautical Journal*, pp. 321-326.

Part of

Thermally driven heat pumps for heating and cooling. – Ed.: Annett Kühn – Berlin:  
Universitätsverlag der TU Berlin, 2013

ISBN 978-3-7983-2686-6 (print)

ISBN 978-3-7983-2596-8 (online)

urn:nbn:de:kobv:83-opus4-39458

[<http://nbn-resolving.de/urn:nbn:de:kobv:83-opus4-39458>]