

HYBRID HEAT PUMP FOR WASTE HEAT RECOVERY IN NORWEGIAN FOOD INDUSTRY

Stein Rune Nordtvedt, Institute for Energy Technology, Instituttveien 18, N-2027 Kjeller
Bjarne R. Horntvedt, Hybrid Energy AS, Ole Deviks vei 4, N-0666 Oslo
Jan Eikefjord, John Johansen, Nortura AS, Rudshøgda, Norway
Stein.Nordtvedt@ife.no

This paper was published in the proceedings of the 10th International Heat Pump Conference 2011 (www.heatpumpcentre.org/en/hppactivities/ieaheatpumpconference).

Abstract: Traditional food companies usually have facilities for the production of refrigeration and steam. Typically, these facilities run independently of each other even if they are a part of the energy system in the companies. There are only a handful of companies that need steam and in most cases hot water up to 80-100°C is sufficient. Institute for Energy Technology has done research on energy recovery in an industrial context, and especially within the food industry since 1995. This has resulted in a hybrid heat pump (compression / absorption heat pump) using a mixture of ammonia and water as working fluid. The hybrid heat pump has the capability to deliver hot water up to 100°C, recovering waste heat at approx 50°C. This paper presents operational experiences with a specific hybrid heat pumps installation at a Norwegian slaughterhouse. The hybrid heat pump recovers heat from the refrigeration system and produce hot water at 90°C.

Key Words: industrial heat pumps, waste heat recovery, ammonia-water mixture

1 INTRODUCTION

Traditional food companies usually have facilities for the production of refrigeration and steam. Typically, these facilities run independently of each other even if they are a part of the energy system in the companies. There are only a handful of companies that need steam and in most cases hot water up to 80-100°C is sufficient.

Institute for Energy Technology has done research on energy recovery in an industrial context, and especially within the food industry since 1995. This has resulted in a hybrid heat pump (compression/absorption heat pump) using a mixture of ammonia and water as working fluid (Nordtvedt 2005). The hybrid heat pump has the capability to deliver hot water up to 100°C, recovering waste heat at approx 50°C. A pilot plant of the hybrid heat pump was installed in a Norwegian dairy in 2000 and after successful operation over several years the company Hybrid Energy AS was founded in 2004. The hybrid heat pump installation that will be described here is the first commercial hybrid heat pump installation in Norway. This heat pump was installed in a slaughterhouse providing hot water for cleaning purposes and has been in operation since 2007.

2 THE HYBRID HEAT PUMP TECHNOLOGY

The combination of an absorption process and a vapour compression process with ammonia-water as working fluid gives a flexible heat pump system. A hybrid heat pump with a 50% mixture of ammonia and water, can heat water to over 100°C with the same pressure

rating/equipment. Then this plant can cover quite different temperature ranges than conventional heat pumps and is particularly interesting in industrial processes.

The hybrid heat pumps (compression/absorption) exhibit some interesting possibilities when compared to conventional vapour compression heat pumps. High heat sink temperatures can be achieved at the design pressures of standard refrigerating components due to the boiling point elevation reached when mixing ammonia with water. The temperature glide of the ammonia-water mixture can be adjusted to the external heat sink/source fluids by adjusting the composition. Changing the average composition of the solution circulating between the absorber and the desorber allows for a change in the saturation pressures in the system, and a capacity control as the compressor is supplied with lower or higher density vapour.

3 SYSTEM DESCRIPTION

Figure 1 shows a sketch of the hybrid heat pump system. The working cycle consists of a solution pump pumping solution rich in water from low pressure to higher pressure, and a compressor which is pressurizing ammonia vapour from low pressure to high pressure. The solution rich in water is mixed with the ammonia vapour in the absorber, and heat is released to the heat sink during the ammonia absorption process. The resulting solution leaving the absorber is rich in ammonia, and is expanded to the low pressure side through the expansion valve before it enters the desorber. There ammonia is evaporated out of the solution by heat extraction from the heat source, and the process repeats itself. A solution heat exchanger is installed for internal heat recovery and increases the cycle efficiency. Figure 2 shows the hybrid heat pump cycle components in a pressure, temperature, concentration (PTX) diagram.

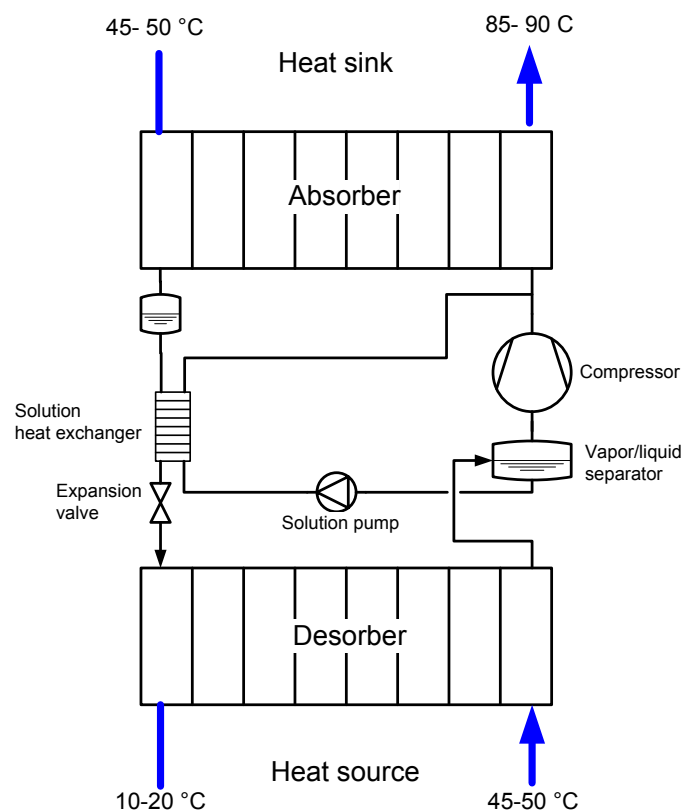

Figure 1: Hybrid heat pump sketch

As the working fluid is a mixture of ammonia and water the evaporation and condensation processes in the desorber and the absorber respectively, will occur at gliding temperatures. The ammonia concentration in the solution will increase in the absorber and the mixture temperature will decrease through the heat exchanger as the saturation temperature of ammonia is considerably lower than the saturation temperature of water. The process is reversed in the desorber where ammonia is evaporated out of the ammonia/water solution, and the saturation temperature in the solution will increase from the inlet to the outlet of the heat exchanger.

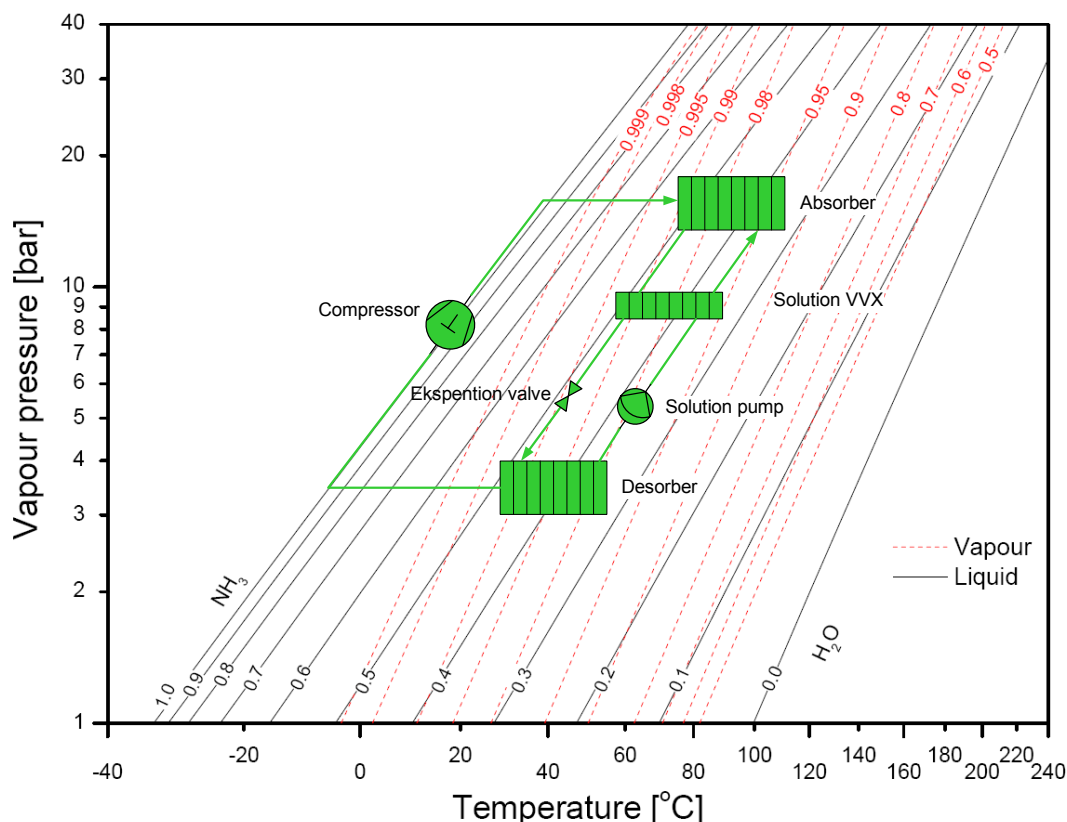

Figure 2: PTX diagram of ammonia-water mixture with hybrid heat pump components

The gliding temperatures of the working fluid mixture during heat extraction in the desorber and during heat release in the absorber can be an advantage in many processes. If the heat source is water that has to be cooled from 40 to 10°C, and the heat sink fluid is water that shall be heated from 50 to 90°C, the temperature glide of the working fluid mixture can be adapted to the temperature glide of the heat sink and heat source fluid. The compressor in the hybrid heat pump will then work against a lower temperature lift than the compressor in a conventional vapour compression heat pump using a pure fluid which experiences a constant temperature during evaporation and condensation.

4 THE HYBRID HEAT PUMP AT NORTURA RUDSHØGDA SLAUGHTERHOUSE

Nortura SA is one of the main suppliers of meat and eggs in Norway, and has 6,100 employees in different industries in 34 municipalities all over the country. The group is organized as a cooperative owned by 25,000 Norwegian farmers (Nortura 2011).

Nortura SA has a slaughterhouse at Rudshøgda in Norway. Nortura Rudshøgda slaughter cattle, pigs and sheep, and do cutting of cattle and pigs. The slaughterhouse produces

steaks/piece of meat, meat cakes, dough and salted/smoked and marinated products. The slaughterhouse need large amounts of hot process water at minimum temperature of 83°C.

In 2007 a hybrid heat pump with a capacity of 650 kW on the hot side was installed for this purpose. The hybrid heat pump is built using a standard reciprocating ammonia compressor and plate heat exchangers as heat exchange components. Figure 3 shows a system sketch of the heat pump installation.

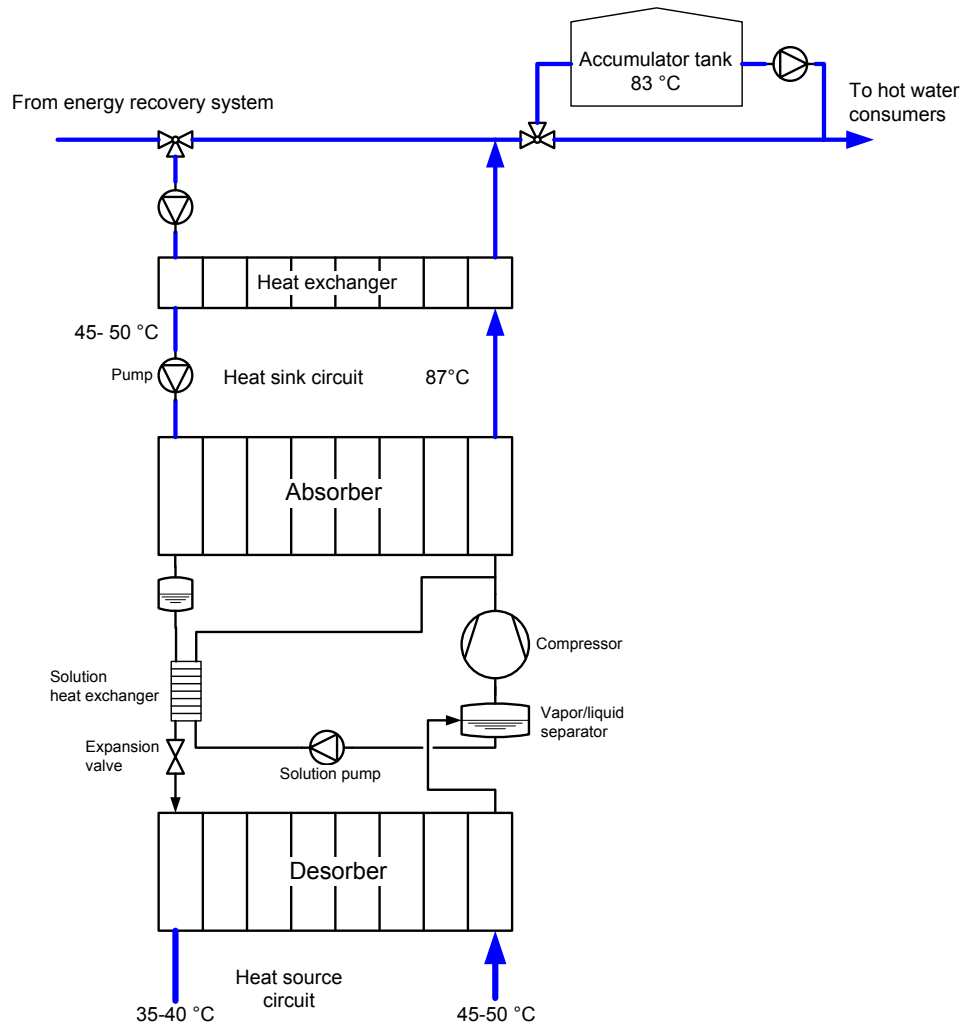

Figure 3: The hybrid heat pump installation at Nortura Rudshøgda

The energy recovery system at Nortura Rudshøgda recovers heat from the refrigeration system on site. Process water is preheated to approximately 50°C with a low-pressure ammonia heat pump system, and then further heated to approximately 83°C with the hybrid heat pump. The hybrid heat pump delivers heat at 87°C to a secondary circuit to avoid contamination of the water for consumption with ammonia in case of a leakage in a heat exchanger.

The heat source of the hybrid heat pump is surplus heat at a temperature of 45-50°C from the low-temperature ammonia compression heat pump plant and waste heat from the cooling/freezing plant.

As a part of the hybrid heat pump installation, a hot water accumulator tank with a capacity of 200 m³ was installed. The accumulator tank gives the Nortura flexibility in the production, as

the hot water supply system manages large water withdrawals over periods without large peaks in the heating system. By heating tap water up to 83°C with recovered heat, the water can be stored without any danger of legionella problems.

The hybrid heat pump installation has showed an average efficiency of 4.5 over three years. The energy recovery system saves in total approximately 3.4 GWh annually.

5 REFERENCES

Nortura 2011. www.nortura.no

Nordtvedt, S.R. 2005. "Experimental and theoretical study of a compression/absorption heat pump with ammonia-water as working fluid," *Doctoral Thesis*, Norwegian University of Science and Technology, 2005:82.

Part of

Thermally driven heat pumps for heating and cooling. – Ed.: Annett Kühn – Berlin:
Universitätsverlag der TU Berlin, 2013

ISBN 978-3-7983-2686-6 (print)

ISBN 978-3-7983-2596-8 (online)

urn:nbn:de:kobv:83-opus4-39458

[<http://nbn-resolving.de/urn:nbn:de:kobv:83-opus4-39458>]