

Utilising flexibility in distribution system operation

Citation for published version (APA):

Fonteyjn, R. (2021). *Utilising flexibility in distribution system operation: Theory and practice*. [Phd Thesis 1 (Research TU/e / Graduation TU/e), Electrical Engineering]. Eindhoven University of Technology.

Document status and date:

Published: 29/10/2021

Document Version:

Publisher's PDF, also known as Version of Record (includes final page, issue and volume numbers)

Please check the document version of this publication:

- A submitted manuscript is the version of the article upon submission and before peer-review. There can be important differences between the submitted version and the official published version of record. People interested in the research are advised to contact the author for the final version of the publication, or visit the DOI to the publisher's website.
- The final author version and the galley proof are versions of the publication after peer review.
- The final published version features the final layout of the paper including the volume, issue and page numbers.

[Link to publication](#)

General rights

Copyright and moral rights for the publications made accessible in the public portal are retained by the authors and/or other copyright owners and it is a condition of accessing publications that users recognise and abide by the legal requirements associated with these rights.

- Users may download and print one copy of any publication from the public portal for the purpose of private study or research.
- You may not further distribute the material or use it for any profit-making activity or commercial gain
- You may freely distribute the URL identifying the publication in the public portal.

If the publication is distributed under the terms of Article 25fa of the Dutch Copyright Act, indicated by the "Taverne" license above, please follow below link for the End User Agreement:

www.tue.nl/taverne

Take down policy

If you believe that this document breaches copyright please contact us at:

openaccess@tue.nl

providing details and we will investigate your claim.

Utilising flexibility in distribution system operation
Theory and practice

PROEFSCHRIFT

ter verkrijging van de graad van doctor aan de Technische Universiteit
Eindhoven, op gezag van de rector magnificus prof.dr.ir. F.P.T. Baaijens,
voor een commissie aangewezen door het College voor Promoties, in het
openbaar te verdedigen op vrijdag 29 oktober 2021 om 16:00 uur

door

Rik Fonteijn

geboren te Weert

Dit proefschrift is goedgekeurd door de promotoren en de samenstelling van de promotiecommissie is als volgt:

voorzitter: prof.dr.ir. S.M. Heemstra de Groot
promotor: prof.dr.ir. J.G. Slootweg
copromotoren: dr. P.H. Nguyen
dr.ir. J. Morren
leden: prof.dr. J.K. Kok
prof.dr. M. Gibescu (Universiteit Utrecht)
prof.dr. S. Repo (Tampere University)
adviseur: dr.ir. M.D. van der Laan (Hanzehogeschool Groningen)

Het onderzoek of ontwerp dat in dit proefschrift wordt beschreven is uitgevoerd in overeenstemming met de TU/e Gedragscode Wetenschapsbeoefening.

The research described in this thesis was performed at the Electrical Energy Systems group of the department of Electrical Engineering at Eindhoven University of Technology. It was carried out in close cooperation with the Dutch distribution system operator Enexis and was part of the European Union's Horizon 2020 project InterFlex.

Printed by Gildeprint - Enschede.

A catalogue record is available from the Eindhoven University of Technology Library.

ISBN: 978-90-386-5347-1

Copyright © 2021 by R. Fonteijn, Nuenen. All rights reserved.

Contact: research@rikfonteijn.nl

Summary

The energy transition is gaining momentum. Sustainable sources such as wind turbines and photo-voltaic (PV) systems are widely introduced in distribution networks. Simultaneously, electrification of transportation and heating adds an increasing amount of new loads (e.g. electric vehicles and heat pumps) to (existing) distribution networks. Traditionally, distribution networks are designed and reinforced based on the expected peak load, to prevent overloading or network congestion. Distribution system operators (DSOs) can however use an alternative, to avoid or postpone reinforcements in case of expected congestion problems, or to overcome the time it takes to complete reinforcements: (demand-side) flexibility.

Various mechanisms (e.g. price-based schemes, tariff changes, flexibility markets, direct control) to unlock flexibility have been considered, analysed and tested in the field. Research so far has shown flexibility is able to solve congestion problems (either completely or partially). The next step in flexibility research is therefore related to its utilisation and remuneration (or settlement) in daily operation. This enables DSOs to actively start applying flexibility as a solution to congestion problems. This thesis focuses on flexibility utilisation in daily operation, and answers the following research question:

"Which local flexibility mechanisms can DSOs use to unlock the necessary flexibility, and how can DSOs decide on daily operation and settlement of flexibility?"

To answer the research question and guide DSOs through the different steps that are required for flexibility utilisation in daily operation, this thesis consists of five core chapters, each with their own sub-topic:

- The chapter *Flexibility in the power system* elaborates on the current developments related to flexibility in the power system. The characteristics of different flexibility sources and the potential applications of flexibility are discussed.

- The chapter *Flexibility mechanisms* discusses different mechanisms (and combinations) with which flexibility can be unlocked. In the context of this thesis, the following mechanisms are considered: flexibility markets, tariff-based flexibility, direct control, and variable connection capacities. Some of these mechanisms have their own sub-categories, on which the chapter elaborates.
- The chapter *Case study* describes the work that has been done in pilot- and demonstration project context. The main part of the discussion is the Dutch demonstration site of the H2020 InterFlex project. On this demonstration site, a local flexibility market is used to solve congestion problems.
- The chapter *Operationalising flexibility* discusses tools a DSO needs to make decisions on the every-day deployment of flexibility for network-support. This is done by introducing a generic, four-step approach: data acquisition, load forecasting, decision-making and flexibility mechanism interfacing. A case-specific implementation provides a proof-of-concept.
- The chapter *Baselining flexibility* elaborates on the settlement challenge. The DSO and flexibility providers need to settle on delivered flexibility. When flexibility is provided, the behaviour of the flexibility source can be captured by load measurements. It is, however, not possible to also measure the behaviour of a flexibility source in case no flexibility would have been provided. The expected behaviour is therefore captured by a baseline, based on which the DSO can settle the delivered flexibility.

The main results and conclusions of this thesis are the following:

- The implementation of the four-step approach to operationalise flexibility shows that by using load forecasting and a decision-making algorithm that takes into account the cost of lifetime reduction in case of overloading, the DSO can make a fair evaluation on whether to buy flexibility or to accept an overloading. This results in competitive prices of flexibility compared to prices occurring on existing wholesale and balancing markets.
- The results from the case study suggest that, in order to guarantee security of supply, DSOs need to take the certainty with which flexibility is available and the reliability with which flexibility is delivered into account. This can for example be achieved by introducing a direct control fall-back mechanism in case the primary flexibility mechanism fails,

and/or stacking long-term bilateral contracts on top of an existing mechanism.

- Traditional baselining methods are not suitable for remunerating variable flexibility sources such as (curtailment of) PV. An alternative approach to determine a baseline for settlement between DSO and aggregator is proposed. This approach combines the historical method with weather data of the moment flexibility is provided. It is shown that this can improve the baseline of PV.
- In order to overcome the gap between theory and practice, many adaptations are required. This thesis illustrates practical application is possible and provides a proof-of-concept for the required decision steps of the DSOs, using a real-life pilot implementation. Solutions however need to be tailored to a use case and further research on different forecasting and decision-making techniques is required.

The main contribution of this thesis can be summarised as follows. By integrating, adapting and expanding on existing research, this thesis proposes practical tools necessary to start utilising flexibility in daily operation to DSOs. These tools are integrated in an integral framework of a four-step approach and enable the DSO to request their flexibility needs from market parties. This thesis illustrates that the proposed concepts can work not only in theory, but can be adapted and used in a practical (pilot) context. Further research on wide-scale practical applications, operational optimisation and decision-making is needed.

Samenvatting

De energietransitie is in volle gang. Duurzame energiebronnen zoals windmolens en zonnepanelen worden in grote getalen geïntroduceerd in onze distributienetten. Tegelijkertijd wordt onze vervoers- en verwarmingsbehoefte geëlektrificeerd met behulp van bijvoorbeeld elektrische auto's en warmtepompen. Deze nieuwe technologieën belasten (bestaande) distributienetten in toenemende mate. De distributienetten worden van oudsher ontworpen en verzaaid op basis van de verwachte piekbelasting, om overbelasting of congestie te voorkomen. Regionale netbeheerders hebben inmiddels een alternatief om, in het geval van verwachte overbelastingen, netverzwaringen te voorkomen of uit te stellen, of om de tijd die netverzwaringen kost te overbruggen: flexibiliteit.

Er zijn verschillende mechanismes om flexibiliteit te ontsluiten onderzocht en in proeftuinen uitgetoet. Voorbeelden hiervan zijn prijs-gebaseerde oplossingen, tariefswijzigingen, flexibiliteitsmarkten en directe aansturing. Onderzoek tot dusver heeft aangetoond dat flexibiliteit een (deel)oplossing kan bieden voor de overbelastingsproblematiek. Een volgende stap is gericht op de toepassing en verrekening van flexibiliteit binnen de bedrijfsvoering, zodat de regionale netbeheerder flexibiliteit actief kan gaan inzetten als oplossing voor congestieproblemen. Dit proefschrift richt zich op de toepassing van flexibiliteit in de dagelijkse bedrijfsvoering en beantwoordt de volgende onderzoeksvraag:

"Welke lokale flexibiliteitsmechanismen kunnen regionale netbeheerders gebruiken om de noodzakelijke flexibiliteit beschikbaar te maken en hoe kunnen regionale netbeheerders beslissingen maken gericht op flexibiliteit in de dagelijkse bedrijfsvoering en de verrekening daarvan?"

Dit proefschrift bestaat uit vijf kernhoofdstukken, welke gezamenlijk deze

onderzoeksvraag beantwoorden. De vijf kernhoofdstukken behandelen elk een deelvraag. De kernhoofdstukken zijn (in volgorde):

- Het hoofdstuk *flexibiliteit in het elektriciteitssysteem* introduceert de huidige ontwikkelingen met betrekking tot flexibiliteit in het elektriciteits-systeem. Hierbij worden de karakteristieken en mogelijke toepassingen van verschillende flexibiliteitsbronnen besproken.
- In het hoofdstuk *flexibiliteitsmechanismes* worden verschillende mechanismes waarmee flexibiliteit kan worden ontsloten geanalyseerd. In de context van dit proefschrift worden de volgende methodes besproken: flexibiliteitsmarkten, tariefswijzigingen, directe aansturing en variabele aansluitcapaciteiten. Elk van deze mechanismes kan op verschillende manieren worden toegepast.
- In het hoofdstuk *case study* beschrijft in de context van dit proefschrift het in proeftuinverband uitgevoerd onderzoek. Het belangrijkste deel van de discussie gaat over de Nederlandse proeftuin van het H2020 project InterFlex. In dit project is een lokale flexibiliteitsmarkt ingezet om congestieproblemen op te lossen.
- Het hoofdstuk *flexibiliteit in de dagelijkse bedrijfsvoering* introduceert handvaten die een regionale netbeheerder nodig heeft om beslissingen te maken over de dagelijkse inzet van flexibiliteit voor netondersteuning. Hiervoor wordt een generieke oplossing aangedragen, bestaande uit vier stappen: data-acquisitie, load forecasting, besluitvorming omtrent inzet en koppeling met flexibiliteitsmechanisme. Het proof-of-concept wordt gegeven door gebruik te maken van een specifieke implementatie binnen een proeftuin.
- Het hoofdstuk *flexibiliteit verrekenen* onderzoekt het verrekeningsproces. De regionale netbeheerder en de flexibiliteitsaanbieders moeten de geleverde flexibiliteit verrekenen. Als er flexibiliteit is geleverd, kan het gedrag van de bron worden gemeten. Het is echter onmogelijk te meten wat het gedrag zou zijn geweest, mocht er geen flexibiliteit zijn geleverd. Het verwachte gedrag wordt daarom beschreven met behulp van een zogenaamde nulmeting (baseline), die de netbeheerder vervolgens kan gebruiken om de geleverde flexibiliteit te verrekenen.

De belangrijkste resultaten en conclusies van dit proefschrift zijn:

- Binnen de implementatie van de vier stappen om flexibiliteit in de dagelijkse bedrijfsvoering in te zetten worden algoritmes gebruikt voor load forecasting en de besluitvorming over flexibiliteitsinzet. Bij de besluitvorming worden de kosten van levensduurverkortung in het geval van overbelasting meegenomen. De regionale netbeheerder kan daardoor een eerlijke vergelijking maken tussen het inkopen van flexibiliteit en het accepteren van een overbelasting. Dit resulteert in een concurrerende prijs voor flexibiliteit, deze vergelijkend met de prijzen op de handels- en onbalansmarkt.
- De resultaten uit de proeftuinen suggereren dat de netbeheerders, om de leveringszekerheid te garanderen, de zekerheid waarmee flexibiliteit beschikbaar is en de betrouwbaarheid waarmee flexibiliteit kan worden geleverd moeten borgen. Dit kan bijvoorbeeld worden gedaan door directe aansturing te gebruiken als terugvaloptie mocht het primaire flexibiliteitsmechanisme falen, en/of door langetermijncontracten te stapelen met het bestaande flexibiliteitsmechanisme.
- Traditionele methoden voor *baselining* zijn niet geschikt voor fluctuerende flexibiliteitsbronnen zoals (de curtailment van) zonnepanelen. Een alternatieve oplossing, om de baseline voor verrekening tussen netbeheerder en aggregator vast te stellen, wordt voorgesteld. Deze voorgestelde methode maakt gebruik van historische metingen, in combinatie met actuele weerdata van het moment van leveren. Dit kan de resultaten van de baseline verbeteren.
- Om het gat tussen theorie en praktijk te overbruggen, zijn vele aanpassingen noodzakelijk. Dit proefschrift laat zien dat praktische toepassing van flexibiliteit mogelijk is. Het biedt verder een proof-of-concept voor de benodigde stappen die een regionale netbeheerder moet doorlopen. Oplossingen implementeren blijft echter maatwerk. Verder zijn verdiepingsslagen noodzakelijk in het onderzoek omtrent load forecasting en besluitvorming omtrent inzet.

De belangrijkste bijdrage van dit proefschrift kan als volgt worden samengevat. Door bestaand onderzoek te integreren, aan te passen en uit te breiden, stelt dit proefschrift praktische handvaten voor die regionale netbeheerders nodig hebben om flexibiliteit actief in te zetten binnen de dagelijkse bedrijfsvoering. Op deze manier laat dit proefschrift zien dat de voorgestelde methodes niet alleen in theorie kunnen werken, maar ook in een praktische (proeftuin-)

context gebruikt kunnen worden. Verder onderzoek naar grootschalige praktische toepassing en optimalisatie van besluitvorming voor bedrijfsvoering is nodig.

Nomenclature

AC	Alternating Current
ASM	Active System Management
BESS	Battery Energy Storage System
BRP	Balance Responsible Party
CA	Commercial Aggregator
CPMS	Charge Point Management System
DA	Distribution Automation
DALI	Distribution Automation Light
DAM	Day-Ahead Market
DC	Direct Current
DER	Distributed Energy Resources
DR	Demand Response
DSO	Distribution System Operator
EC	European Commission
EFI	Energy Flexibility Interface
EV	Electric Vehicle
EVCP	Electric Vehicle Charge Point

FAP	Flexibility Aggregation Platform
FCR	Frequency Containment Reserves
FRR	Frequency Restoration Reserves
GHG	Greenhouse Gas
GMS	Grid Management System
GOPACS	Grid Operator Platform for Congestion Solutions
HH	Household
HP	Heat Pump
ICT	Information and Communication Technology
LA	Local Aggregator
LIMS	Local Infrastructure Management System
LV	Low Voltage
MAE	Mean Absolute Error
MAPE	Mean Average Percentage Error
MV	Medium Voltage
MV/LV	Medium-to-Low Voltage
NOP	Normally Open Point
OCPI	Open Charge Point Interface
PoC	Point of Connection
PQ	Power Quality
PTU	Program Time Unit
PV	Photo-Voltaic
RES	Renewable Energy Sources
RMSE	Root Mean Square Error

RTU	Remote Terminal Unit
SGAM	Smart Grid Architectural Model
SQ	Sub-Question
TLC	Total Lifetime Cost
TSO	Transmission System Operator
UFTP	USEF Flexibility Trading Protocol
USEF	Universal Smart Energy Framework
V2G	Vehicle-to-Grid

Contents

Summary	vii
Samenvatting	xii
Nomenclature	xv
Contents	xx
1 Introduction	1
1.1 Power system in transition	1
1.1.1 Traditional power system	1
1.1.2 The energy transition	2
1.1.3 Renewable energy sources	3
1.1.4 Electrification	5
1.2 Problem definition	7
1.3 Research description	8
1.4 Thesis outline	11
2 Flexibility in the power system	13
2.1 Introduction	13
2.2 Roles in the power system	13
2.3 Flexibility	15
2.4 Flexibility sources	18
2.5 Applications	22
2.6 DSO perspective	26
2.7 Conclusions	28

3	Flexibility mechanisms	29
3.1	Introduction	29
3.2	Flexibility mechanisms	29
3.2.1	Flexibility markets	31
3.2.2	Tariff structures	34
3.2.3	Direct control	38
3.2.4	Variable connection capacity	39
3.2.5	Combinations and hybrids, and others	42
3.3	DSO perspective	43
3.4	Conclusions	45
4	Case study	47
4.1	Introduction	47
4.2	InterFlex: Dutch sub-project	47
4.2.1	Project description	48
4.2.2	Pilot design	51
4.2.3	Insights from the demonstrator	58
4.2.4	Reflection	62
4.3	Other developments	64
4.4	Conclusions	65
5	Operationalising flexibility	67
5.1	Introduction	67
5.2	Operationalisation of the flexibility need	68
5.3	A four-step approach for flexibility operation	69
5.3.1	Step 1. Data acquisition	69
5.3.2	Step 2. Load forecasting	70
5.3.3	Step 3. Decision-making	74
5.3.4	Step 4. Flexibility mechanism interfacing	75
5.4	Implementation	78
5.4.1	Step 1. Data acquisition	78
5.4.2	Step 2. Load forecasting	79
5.4.3	Step 3. Decision-making	82
5.4.4	Step 4. Flexibility mechanism interfacing	87
5.5	Results & discussion	88
5.5.1	Step 1. Data acquisition	88
5.5.2	Step 2. Load forecasting	88
5.5.3	Step 3. Decision-making	90
5.5.4	Step 4. Flexibility mechanism interfacing	95
5.6	Conclusions	97

6	Baselining flexibility	99
6.1	Introduction	99
6.2	Baselines in literature	101
6.2.1	Evaluation criteria	102
6.2.2	Baseline methodologies	104
6.3	Methodology	109
6.3.1	Selected baseline methods	110
6.3.2	DSO - aggregator interface	110
6.3.3	Input data	111
6.3.4	PV model	111
6.3.5	Implementation	112
6.4	Results	118
6.4.1	Weather profiles	119
6.4.2	Reference profile	119
6.4.3	Curtailement profiles	121
6.4.4	Baselining methods	122
6.4.5	Error metric	127
6.4.6	Discussion	129
6.5	Conclusions	130
7	Conclusions, contributions, and recommendations	131
7.1	Conclusions and contributions	132
7.2	Recommendations	135
A	Electric vehicle flexibility	137
B	SGAM Dutch InterFlex sub-project	139
C	Baselining practices in literature	147
D	Additional error metrics	151
	Bibliography	172
	List of Figures	176
	List of Tables	177
	List of Publications	181
	Acknowledgements	184

Curriculum Vitae

185

1 | Introduction

1.1 Power system in transition

This section introduces the traditional power system, followed by background information on the energy transition, the introduction of renewable energy sources and the electrification of transportation and heating systems.

1.1.1 Traditional power system

The traditional power system is a vertically integrated system in which generation, transmission and distribution are operated by a single entity [1]. The system is organised top-down, with large-scale, central (often fossil fuel based) generators feeding into the high-voltage (110 kV-380 kV) transmission system. The transmission system transports large volumes of electricity over relatively long distances and connects some large industrial loads. The majority of loads is however found in the distribution system, which is operated on medium-voltage (1 kV-50 kV) and low-voltage (<1 kV) levels. The medium-voltage (MV) networks typically supplies medium-sized industrial and commercial loads, while the low-voltage (LV) networks connect small-sized commercial and residential loads. Figure 1.1 gives a schematic overview of a traditional power system, with large-scale generation in top and small-scale, residential loads in the bottom.

Over the past decades, the European power sector has been liberalised. Generation of electricity has been separated from transmission and distribution [2], the so-called *unbundling*. This introduces market competition and gives consumers free choice of supplier [3]. As a result of the unbundling in the Netherlands, TenneT as a transmission system operator (TSO) became responsible for the operation of the Dutch transmission system. The distribution networks are operated by different distribution system operators (DSOs),

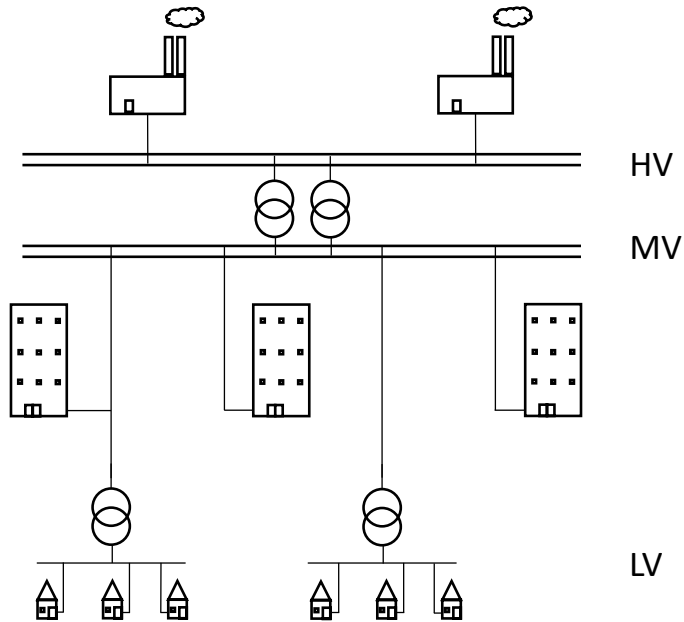

Figure 1.1: Schematic overview of a traditional power system.

such as the largest three Dutch DSOs Enexis, Liander, and Stedin. Similar situations can be observed elsewhere, both inside and outside the EU.

1.1.2 The energy transition

The energy transition is currently gaining momentum. Three main drivers for a sustainable future can be identified: climate change, resource depletion, and energy security [1, 4]. In 1987, the Brundtland report identified non-sustainable production and consumption as a driver for environmental problems [5]. In the following decades, consensus on the issue of climate change was reached. Currently, long-term policies steering towards a reduced environmental impact are implemented. The Kyoto protocol (1997) presented a pricing mechanism to be placed on greenhouse gasses (GHGs), aiming at a reduced environmental impact [4]. In 2007, the European Commission (EC) presented a climate and energy package [6]. In this package, the targets for 2020 were published, making an initial step towards a sustainable European Union (EU). The package states the following three key objectives:

- A 20% reduction in EU GHG emissions, compared to the reference year 1990;
- A total of 20% of the primary energy consumed is produced by RES;
- A 20% improvement in EU energy efficiency.

In December 2015, during the United Nations Climate Change Conference, around 190 countries adopted the Paris Agreement, in order to keep the global average temperature increase lower than 2 °C, aiming for a maximum increase of 1.5 °C [7]. In 2020, the EC proposed to raise the European Union's GHG reduction target for 2030 even further, to 55% compared to 1990 [8]. The following three objectives are defined to achieve this reduction:

- A minimum reduction of 40% in EU GHG emissions, compared to the reference year 1990 levels;
- A minimum share of 32% renewable energy;
- An improvement of at least 32.5% in terms of energy efficiency.

By 2050, the EU aims to have a net-zero GHG emission economy [9].

Two more drivers were identified: resource depletion and energy security. The annual energy review of BP provides an overview of the expected reserves of fossil fuels [10]. BP uses the known reserves and current rate of fuel extraction as base assumption for their estimates. Keeping the increase in energy consumption by developing economies in mind, an urge for alternative, sustainable sources of energy becomes clear. As primary energy sources like wind and solar are typically inexhaustible [11], a transition to a sustainable energy supply solves the challenge of resource depletion.

Energy security is the third driver. In 1973 and 1979, the first and second oil crisis occurred, limiting the availability of oil in western countries [4]. This started the discussion on energy security and the desire of countries to be able to fulfil in their own energy demand. The Ukrainian gas-crisis of 2009 [12] and the conflict between Russia and Ukraine in 2014 [13] fueled this discussion. Moving towards a sustainable European energy supply would present an opportunity to gain energy-independence from external countries.

1.1.3 Renewable energy sources

Renewable energy sources (RES) are energy sources that renew or replenish themselves naturally [14]. RES derive energy directly (e.g. thermal, photo-electric) or indirectly (e.g. wind, hydro, photo-synthetic biomass) from the sun

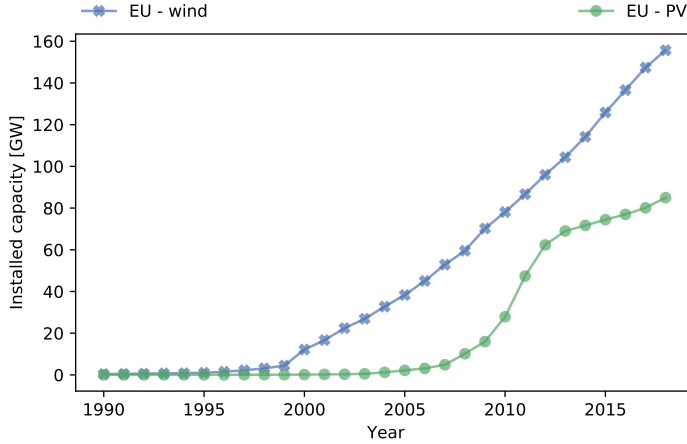

Figure 1.2: Increase in installed capacity of wind and solar PV in the EU.

or from other natural movement or mechanisms (e.g. geothermal, tidal) [11]. RES are therefore considered a sustainable alternative to fossil fuels. In 2018, the EU's share of energy from RES is 32% (the Netherlands 15%) [15]. In the power sector, two RES grow particularly quick: wind turbines and photovoltaic (PV) systems. Figure 1.2 shows the increase in installed capacity of wind turbines and PV systems in the European power system. Figure 1.3 shows the data for the Netherlands¹. It can be observed that the installed capacity increased rapidly after the year 2000.

Integrating RES in the current power system provides challenges. Solar PV systems and (individual) wind turbines are often connected to the distribution networks [1]. The distribution networks traditionally are not designed for distributed generation. RES integration therefore poses several challenges, such as network overloading, voltage violations, power quality, and fault protection issues [19].

Supply and demand of electricity furthermore have to be in continuous balance [1, 20]. This balance is traditionally maintained by adjusting generation to demand. However, due to the weather dependency, generation from wind turbines and solar PV cannot be controlled. When introducing large amounts of wind turbines and PV systems in the power system, demand-side adjustments are therefore required to maintain the system's balance.

¹Data for the EU from [16] and for the Netherlands from [17, 18].

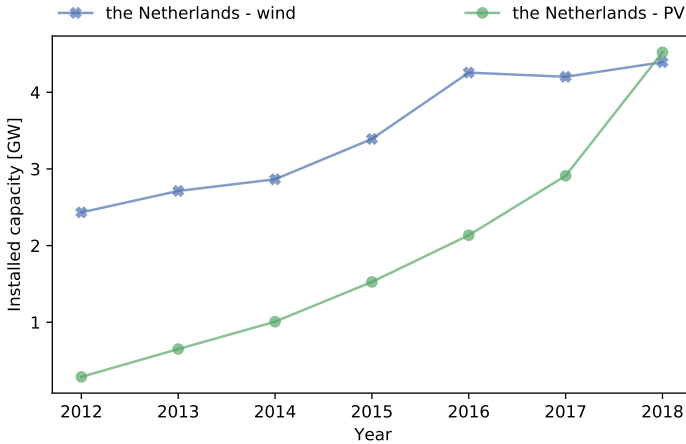

Figure 1.3: Increase in installed capacity of wind and solar PV in the Netherlands.

A potential solution to the balancing, voltage violation, fault protection and network overloading problems is flexibility. Flexibility refers to the power system’s ability to adjust supply or demand. Chapter 2 will elaborate further on this topic.

1.1.4 Electrification

In an effort to reduce greenhouse gas emissions to the agreed levels, another trend can be observed: electrification. Examples are the electrification of transportation and heating systems. Increasing numbers of electric vehicles (EVs) and heat pumps (HPs) are introduced in the distribution networks, adding an additional load to the power system. For the Netherlands alone, electric vehicle numbers more than ten-folded over the last five years [21]. This growth is exponential, as can be observed in figure 1.4².

A similar trend can be observed in heating systems. Dutch households were traditionally connected to natural gas infrastructure to heat their homes. Since July 1, 2018 the Dutch government has decided newly build houses will no longer be connected to natural gas infrastructure and need an alternative heating system [22]. The amount of newly installed HPs has grown significantly ever since. Between 2018 and 2019, 166010 new heat pumps have been

²Data from [21].

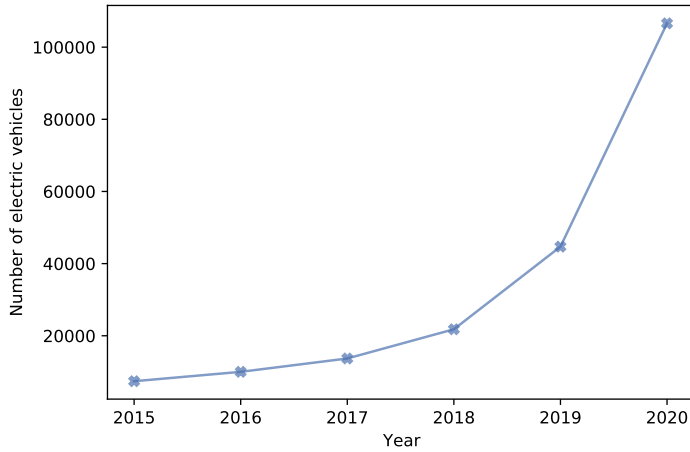

Figure 1.4: Increase in numbers of electric vehicles in the Netherlands.

installed [23], as indicated in figure 1.5³. The Dutch climate agreement furthermore states that by 2050, another seven million households and one million buildings need to be disconnected from natural gas [24], further pushing the need of alternative heating systems like HPs⁴.

The loads from EVs and HPs drastically change the load profiles in the distribution system. This is partly because of size of these loads (see section 2.4 for a more elaborate description of the load behaviour of EVs and HPs). Another important aspect is the coincidence factor: when it is cold weather, all houses need to be heated at (nearly) the same time, resulting in a large load for the power system [2]. When people get home from work, their EVs get charged, adding to the (already existing) evening peak. Distribution networks (especially existing ones) therefore potentially face network overloading, as they are not designed to accommodate these developments and reinforcements are costly and labour intensive.

³Data from [23].

⁴Besides HPs, biogas, hydrogen and district heating will also play a role in the climate neutral heating system of the future.

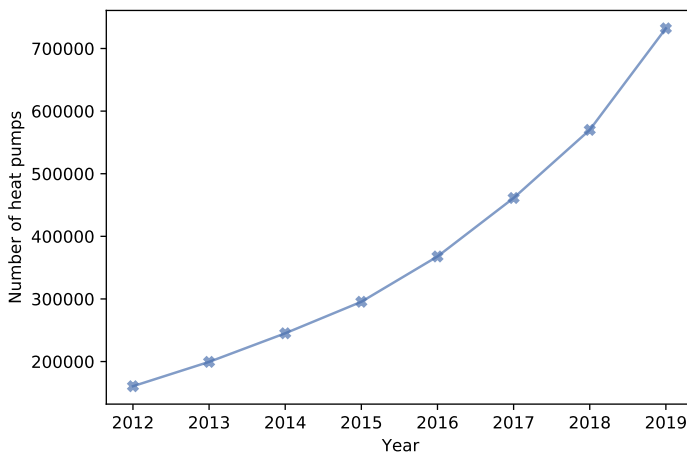

Figure 1.5: Increase in numbers of heat pumps in the Netherlands.

1.2 Problem definition

Due to the energy transition, new energy technologies (e.g. electric vehicles, heat pumps) and (distributed) renewable energy sources (e.g. solar photovoltaic, wind turbines) find their way into the electrical distribution systems at an increasing rate. The distribution network's load profiles change and the peak demand potentially increases. As a result, distribution system operators (DSOs) expect network overloading, also known as congestion. DSOs traditionally solve or prevent congestion by reinforcing the networks, which is costly and time-consuming. An alternative solution to avoid or postpone reinforcements, or to overcome the time it takes to complete reinforcements, is however available: the utilisation of flexibility.

Until now, flexibility research mainly focused on the application of a particular technology (e.g. flexibility from curtailment of PV, smart charging of electric vehicles), on various mechanisms to unlock flexibility (e.g. price-based schemes, tariff changes, flexibility markets), or on topics like customer involvement. It has been shown that technical opportunities exist, and customer engagement is present when presented with the right incentives (for example by [25, 26]). However, integrating the different aspects and providing DSOs with the necessary tools to utilise flexibility for congestion management in daily operation, is a topic that has not yet been extensively researched.

This thesis therefore focuses on flexibility utilisation in daily operation from a distribution system perspective.

1.3 Research description

The description of the research presented in this thesis is split into three parts. First, the main research question of this thesis is presented. This is followed by the sub-questions that have to be answered first. Finally, the scope of this thesis is defined.

Research question

The main research question this thesis will answer is: *Which local flexibility mechanisms can DSOs use to unlock the necessary flexibility, and how can DSOs decide on daily operation and settlement of flexibility?*

Sub-questions

To answer the main research question, a number of sub-questions (SQs) need to be answered, each linked to a chapter of this thesis. The first two SQs are linked to the state-of-the-art and background chapters of this thesis, whereas the remaining SQs are linked to the the core research chapters of this thesis:

- SQ1: What are current developments related to flexibility in the distribution networks, and which of these developments can DSOs make use of?
- SQ2: Which different flexibility mechanisms can DSOs use to unlock flexibility in distribution networks?
- SQ3: Which insights can be derived from a specific demonstration project, for the benefit of every-day deployment of flexibility by DSOs?
- SQ4: What tools do DSOs need to make decisions on the every-day deployment of flexibility for network-support, and how can DSOs apply these tools?
- SQ5: How can DSOs settle the delivered flexibility with the market, ex-post, and what are suitable solutions to use in daily operation?

Scope

In order to clarify what is included in and what is excluded from this research, the scope of this thesis is defined in this section.

In scope

Distribution networks: This research focuses on flexibility applications in a distribution network. Depending on the specific solution, this ranges from low-voltage (LV) feeders up to medium-voltage (MV) transformers.

Flexibility applications for congestion management: Flexibility has many applications, related to network-support in distribution networks and beyond. This thesis focuses on flexibility applications for congestion management.

DSO-aggregator interface: The work presented in this thesis takes the perspective of the DSO. The interface between the DSO and aggregator is taken into account, as this is the source of flexibility from a DSO perspective. Flexibility is therefore considered in a generic manner, without too much emphasis on specific sources and/or suppliers.

Daily operation or every-day deployment of flexibility: This thesis proposes tools a DSO can use to make decisions on the every-day deployment of flexibility. The focus is to provide a generic solution, that is both scalable and easily adapted to a case-specific situation. The development of under-laying algorithms (e.g. load forecast, decision-making algorithm) are in themselves not a goal and are considered to be interchangeable for alternative algorithms.

Generic framework: This thesis takes the perspective of DSOs. From a DSO perspective, the source of flexibility is irrelevant, as long as the needs and requirements of the DSO are met. The framework proposed in this thesis is therefore generic and technology agnostic with regards to the source of flexibility.

Flexibility settlement: The settlement of flexibility, ex-post, is one of the challenges that still need to be resolved. This thesis proposes solutions for the remuneration of aggregators providing flexibility to the DSO. The proposed solutions should be simple and transparent to guarantee market acceptance. Settlement with individual flexibility assets is explicitly not considered.

Out of scope

Transmission networks: This thesis focuses on flexibility applications in distribution networks. Transmission network (networks with a voltage above

50 kV) are not considered. Some of the solutions proposed in this thesis might however also find their application in the transmission network, after minor modifications.

Flexibility applications other than for congestion management: Flexibility has many applications, beyond congestion management (e.g. system balancing, portfolio balancing, congestion management in transmission networks). Many related flexibility products are similar to the ones used for congestion management, however are not in the domain of the DSO and therefore not considered in this thesis.

Interfaces other than DSO-aggregator: Flexibility aggregators have multiple interfaces to consider. Examples are (but not limited to): interfaces with the TSO, interfaces with (individual) flexibility assets, and interfaces with wholesale and balancing markets. Although this thesis takes into account aggregators can trade flexibility through multiple interfaces, due to the DSO perspective these interfaces are not explicitly considered.

Network planning: This thesis provides an overview of different mechanisms a DSO can use to unlock flexibility from the distribution network. It furthermore addresses the challenges a DSO faces when applying flexibility in daily operation. In-between, a DSO needs to decide when to reinforce the distribution network and when to use flexibility as an alternative or temporary solution (including the mechanism that will then be applied). This decision lays in the network planning domain and will not be treated in this thesis.

Customer engagement, aggregator participation, and market liquidity: Customer engagement, aggregator participation, and market liquidity are preconditions to enable flexibility for congestion management. However, this thesis focuses on tools DSOs need to be able to apply flexibility in daily operation. Research related to customer engagement, aggregator participation, aggregator profit maximisation, and market liquidity is therefore not part of this thesis.

Regulatory framework: In order to enable the application of flexibility, changes in the regulatory framework are required. Additionally, the choice on whether to apply a market-based or technical solution for congestion management is a political and societal one. The Dutch regulator currently seems to favour market-based mechanisms. The work described in this thesis focuses on enabling DSOs to apply flexibility from a practical perspective. The necessary regulatory changes to facilitate this and evaluating which mechanism to choose are therefore not within the scope of this thesis.

Forecasting and decision-making algorithms: The DSO's ability to forecasting loads accurately on a short-term and translate this forecast into a decision is a requirement in order to be able to apply flexibility. This thesis however focuses on methods to enable DSOs to apply flexibility in daily operation. While introducing a generic four-step approach is in scope, the under-laying algorithms related to forecasting and decision-making are considered to be interchangeable. Research focusing on the specifics of load forecasting and decision-making algorithms are therefore out of scope.

1.4 Thesis outline

The body of this thesis is organised in six chapters. Figure 1.6 provides a schematic outline of the thesis, including the relationship between chapters and sub-questions (SQs). Chapters 2 and 3 are background chapters, describing the state-of-the-art of their respective topics, whereas chapters 4, 5, and 6 focus on the core research of this thesis.

Chapter 2 - Flexibility in the power system - is a background chapter. The chapter elaborates on the current developments related to flexibility in the power system. The characteristics of different flexibility sources and potential applications of flexibility are discussed. In this chapter, SQ1 is answered.

Chapter 3 - Flexibility mechanisms - discusses different mechanisms with which flexibility can be unlocked, and the characteristics of these mechanisms. The following mechanisms are considered: direct control, tariff-based flexibility, and flexibility markets. Each of these mechanisms have their own sub-categories, on which the chapter elaborates. With that, the answer to SQ2 is provided.

Chapter 4 - Case study - describes work that has been done in pilot- and demonstration project context. The main part of the discussion is the Dutch demonstration site (or sub-project) of the European Union funded H2020 InterFlex project. In this sub-project, a local flexibility market is used to solve congestion problems. This chapter provides an answer to SQ3.

Chapter 5 - Operationalising flexibility - discusses tools a DSO needs to make decisions on the every-day deployment of flexibility for network-support. This is done by introducing a generic, four-step approach: data acquisition, load forecasting, decision-making and flexibility mechanism interfacing. A case-specific implementation in the context of the Dutch InterFlex sub-project provides a proof-of-concept. This results in an answer to SQ4.

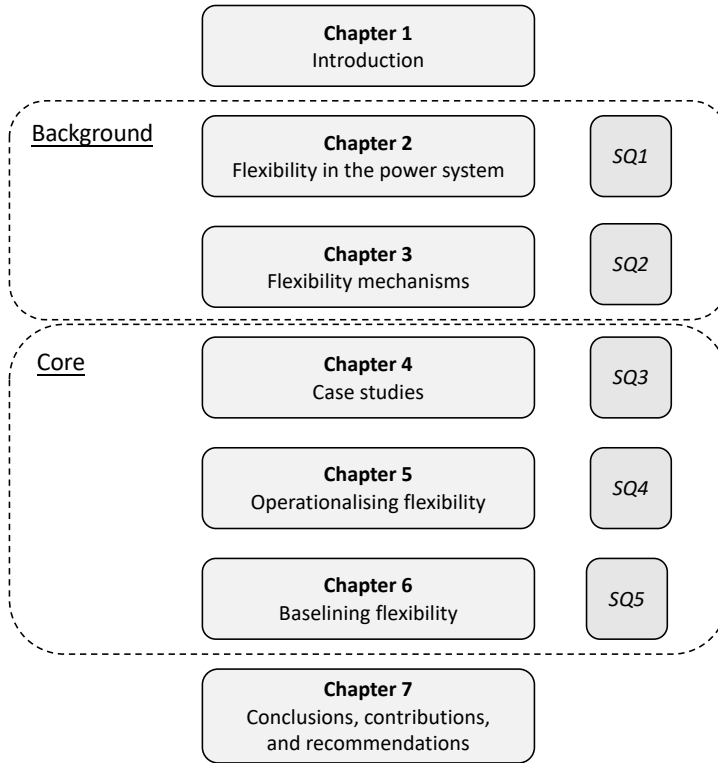

Figure 1.6: Schematic outline of the thesis and the relationship between chapters and sub-questions (SQ).

Chapter 6 - Baselining flexibility - elaborates on the settlement challenge. The DSO and flexibility providers need to settle on delivered flexibility. When flexibility is provided, the behaviour of the flexibility source can be captured by load measurements. It is, however, not possible to also measure the behaviour of a flexibility source in case no flexibility would have been provided. The expected behaviour is therefore captured by a baseline, based on which the DSO can settle the delivered flexibility. This chapter answers SQ5.

Chapter 7 - Conclusions, contributions, and recommendations - presents an overview of the main conclusions, conclusions, and recommendations of this thesis. The chapter will furthermore answer the main research question and elaborate on the contributions of this thesis.

2 | Flexibility in the power system

2.1 Introduction

This chapter discusses literature and provides background on current developments related to flexibility in distribution networks and which of these developments DSOs can use. The central research question of this chapter is *What are current developments related to flexibility in the distribution networks, and which of these developments can DSOs make use of?*

This question is twofold: the current developments related to flexibility in distribution networks, and how these developments relate to DSOs. The first part is answered discussing the following topics:

- Roles in the power system (section 2.2);
- The concept and definition of flexibility (section 2.3);
- Different sources of flexibility in the distribution network (section 2.4);
- Applications of flexibility (section 2.5).

Then, this chapter reflects on these topics from a distribution system operator perspective (section 2.6), answering the second part of the chapter's central question. The chapter ends with an overview of the main conclusions.

2.2 Roles in the power system

This section briefly elaborates on the roles in the power system, that are related to flexibility provision. Depending on the market organisation of a country and

the choices of different stakeholders, each stakeholder can have one or more roles. A more elaborate list of power system roles can be found in the ENTSO-E harmonised electricity market role model [27]. With the exception of the aggregator role, all of the roles introduced in this section are treated in the harmonised electricity market role model.

Transmission system operator

The *transmission system operator* (TSO) is responsible for the transmission system and the system balance in the TSO's operating area. Most European countries have a single TSO. Germany has multiple TSOs. In the Netherlands (and in a part of Germany), TenneT is the TSO [28].

Distribution system operator

Distribution system operators (DSOs) are responsible for the distribution networks. Most European countries have multiple DSOs. Some countries, like Finland and Germany have many small DSOs, while France for example has a single dominant DSO [29]. In the Netherlands, the three largest DSOs (Enexis, Liander and Stedin/Enduris) control nearly all of the distribution networks [30].

Balance responsible party

Balance responsible parties (BRPs), also known as program responsible parties, are responsible for the feed-in and withdrawal of energy in an imbalance settlement period (also known as program time unit or PTU) and within a balancing zone. BRPs (ex-ante) submit energy programs, or prognoses, to the TSO. These programs contain information on the expected amounts of feed-in and withdrawal per PTU and are used by the TSO to (ex-post) settle system imbalances with the BRPs that caused the imbalances [20].

Aggregator

The *aggregator* (ENTSO-E: resource aggregator [27]) aggregates available flexibility from sources located at industrial, commercial and/or residential consumers. The aggregator then offers this flexibility pool to interested stakeholders. This can for example be sold to distribution system operators to prevent congestion. The role aggregator can both be operated independently, or in combination with (for example) a BRP. Both parties trading aggregated flexibility and parties technically unlocking flexibility (service providers, for

example EV charge point operators) are considered to be aggregators. In section 4.2.2, these two types of aggregators are further distinguished.

Energy producer

Energy producers produce electricity. Traditionally, energy producers used large-scale, fossil-fuel powered plants for this. However, more and more electricity is being produced with renewable energy sources. By controlling production output, energy producers can make supply-side flexibility available.

Energy supplier

Since the unbundling, *energy supplier* can be considered as an independent role. The energy supplier procures electricity through bilateral agreements or on the wholesale market and supplies this electricity to consumers and other end users.

Consumer

The *consumer* is the end user of electricity and the owner of assets (e.g. EVs, HPs, white good appliances, batteries) that can potentially be operated such that flexibility becomes available. As consumers at increasing frequency also produce electricity (for example with PV systems), this role is also known as *prosumer* (producing consumer)¹.

2.3 Flexibility

Conceptually, flexibility² refers to the power system's ability to adjust supply or demand, e.g. to ensure a system balance or prevent component overloading [32]. Flexibility can (for example) be achieved through: adjusting supply to demand (e.g. through unit commitment and economic dispatch), load shedding or peak clipping, valley filling, power exchange through interconnections or by (large-scale) storage based on pumped hydro [33, 34]. In the context of this thesis, flexibility is limited to demand-side flexibility³ (or demand response) and flexibility through curtailment, as these are the forms of flexibility typically found in distribution networks.

¹Kotilainen wrote her thesis on the role of prosumers in the power system. For additional information and a better understanding of the role *prosumer*, refer to [31].

²For mechanisms to unlock flexibility as a service, see section 3.2.

³Including battery energy storage systems.

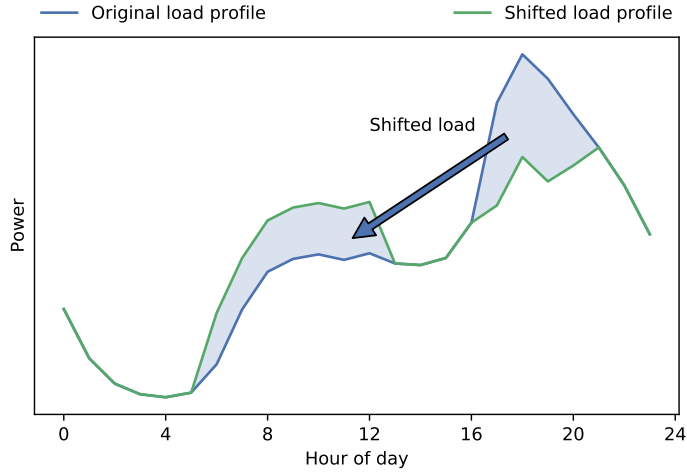

Figure 2.1: Example of load shifting.

Demand-side flexibility is typically realised by deliberately moving loads from one timeslot to a different timeslot. This is known as load shifting [33]. When applying load shifting for congestion management, it must be ensured that the shifted load does not create a new problem at a different moment of time. Figure 2.1 gives an example of a shifted peak load. In this example the shifted load is moved to an earlier timeslot. However, loads can also be shifted to a later moment in time.

A definition of curtailment can be adapted from [35]. Curtailment is the reduction of the output of generation to an output level lower than the current availability of the generators. As curtailment often occurs during peak production, it is also known as peak clipping [33]. Figure 2.2 provides an example of a curtailed PV profile.

Literature defines flexibility in various ways using different parameters, depending on its application. The International Energy Agency defines flexibility from a system perspective, as the extent to which the power system can modify electricity production or consumption in response to variability, expected or otherwise [36]. Taking the perspective of the system operators, both transmission and distribution, flexibility can be defined as the active management of an asset that can impact system balance or network power flows on a short-term basis (from day-ahead to real time) [37]. Furthermore, the use of flexibility for

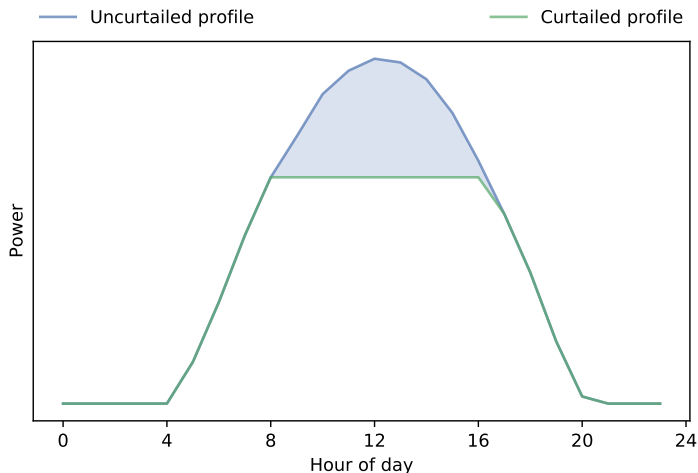

Figure 2.2: Example of curtailment of a solar PV profile.

different market parties is identified as follows [34, 37]:

- Transmission system operators can use flexibility for system balancing and congestion management;
- Distribution system operators can use flexibility for congestion management;
- Balancing responsible parties can use flexibility for portfolio management.

These same applications are also identified by [38]. Furthermore, [38] identifies the importance of parameters to characterise flexibility, such as the amount of power of a load that can be altered, the rate of change, the response time, and the location of the asset. The parameters which are relevant can vary, depending on the perspective in which flexibility is applied.

This thesis focuses on flexibility for congestion management, from a DSO perspective. In that case, the parameters of flexibility can be limited to location, period (also known as duration), time and (potential) power adjustment. These parameters can be found in the definition by [39], which is adapted for this thesis. Flexibility is here defined as *the possibility to adjust power at a given moment in time for a given period at a specific location*.

2.4 Flexibility sources

Flexibility can be provided by various assets in the power system. The list of assets discussed in this section is limited to common flexibility sources in distribution networks. Flexibility sources can provide flexibility for different applications, depending on the type of flexibility source. Customers can maximise their profit by offering flexibility to one or more (competing) applications.

This section focuses on flexibility sources, section 2.5 elaborates on different applications of flexibility, and chapter 3 focuses on different mechanisms to unlock flexibility.

Electric vehicles

With the increasing numbers of EVs (towards a total of two to four million in the Netherlands by 2050 [40]), the distribution network's peak load as a result of EV charging grows rapidly (already 35% of the charge stations analysed by ElaadNL have a charging power of 10 kW or more [41]). This is especially the case when EVs would all start charging at the same time, for example upon arriving home⁴.

The charging behaviour causing the peak load can be categorised in three clusters: private (e.g. residential), public (e.g. charging at a store or in town) and workplace (e.g. at the office) [41]. Two main time-slots of charging can be differentiated: between 8:00 and 9:00 when arriving at work, and between 17:30 and 18:30 when arriving at home. It is furthermore shown by [41] that the amount of charging events in these time-slots are particularly high during weekdays, whereas the amount of charging events during weekends are significantly lower.

Flexibility from EVs can be used for different purposes, including the reduction of this peak load (see section 2.5 for the different applications of flexibility). Flexibility for EVs is commonly unlocked by applying so-called smart charging, which can be combined with vehicle-to-grid technology. These technologies are briefly discussed in appendix A.

One of the challenges with flexibility is the predictability of loads. This is in particular the case for EVs and their charging behaviour. When EVs need to provide flexibility for power system purposes, the amount of available flexibility needs to be forecasted. In particular for localised congestion problems, forecasting/making day-ahead prognoses remains an open challenge [42].

⁴Typically the average per household peak loading of Dutch households, observed at the medium-to-low voltage transformer, is around 1 kW-1.2 kW peak [2].

Photo-voltaic

Solar photo-voltaic (PV) systems are fast-growing in numbers, as shown in section 1.1.3. This is true for both small-scale PV systems of a few (tens of) kW (e.g. for households) as well as large-scale systems of up to several MW. Especially these large-scale systems, connected to MV networks, potentially overload distribution networks. In parts of the Dutch distribution networks congestion is already an issue. This can be observed in the MV network maps of the three largest Dutch DSOs [43, 44, 45] and in figure 2.3. As DSOs are obliged to connect customers, the networks are congested, and reinforcements take time, flexibility can be used as an intermediate solution in order to connect additional PV systems with the available network capacity. The Dutch system operators and regulator are currently in discussion over the required regulatory framework [46].

Since electricity generation by PV systems is weather dependent and cannot be controlled, flexibility from solar PV systems can be achieved by applying curtailment. Flexibility through curtailment is a widely researched solution. In [48], PV curtailment and battery storage in a residential area are compared. In this study, battery storage is evaluated as an alternative to PV curtailment and deferral of network reinforcements. This study shows PV curtailment is the most cost-effective solution. In [49], curtailment is evaluated from the perspective of network planning. It presents a formulation to minimise the annual amount of curtailed energy. In [50], curtailment is evaluated from the perspective of the aggregator. The study presents aggregation algorithms, aggregating loads that can be shedded and generation that can be curtailed into flexibility products. Practical implementations of flexibility through PV curtailment can be found in for example [51, 52].

Battery energy storage systems

Battery energy storage systems (BESSs) need a control strategy to decide when to charge and discharge. BESSs are therefore intrinsically flexible. BESSs can be installed in various different locations of the power system: on household level (as is applied in for example [53], in distribution networks (as is applied in for example [54, 55, 56]) and on transmission system level (as is applied in for example [57]). One of the advantages of applying a BESS is its versatility. It can be adapted for many different flexibility applications, and is often able to serve multiple objectives (more on the applications of flexibility in section 2.5). Examples of multi-objective applications can be found in [58, 59, 60].

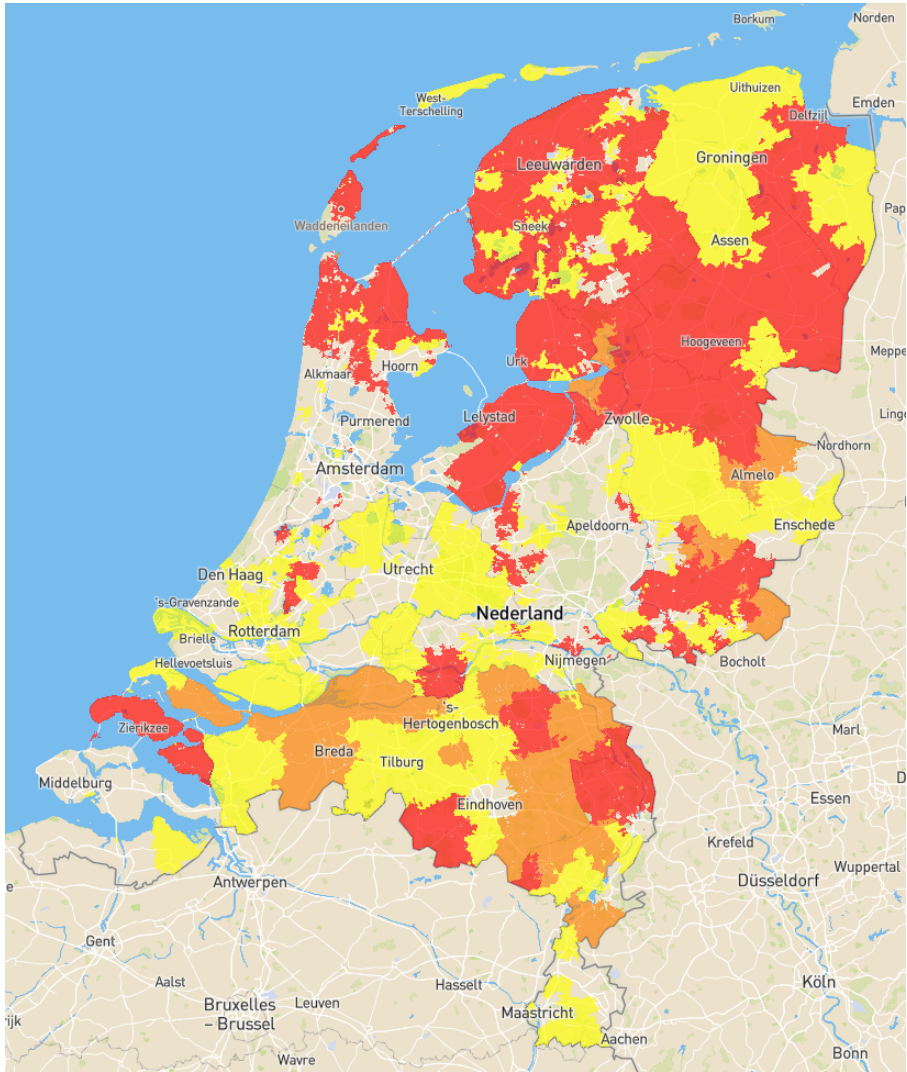

Figure 2.3: Overview of feed-in congestion in the Netherlands. Red indicates no transport capacity is available, orange indicates the potential for congestion management is under review and yellow indicates limited transport capacity is available. Source figure: [47].

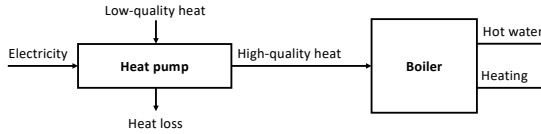

Figure 2.4: Schematic overview of the energy flows in a heat pump.

Heat pumps

Heat pumps (HPs) are thermostatically controlled loads used for heating and cooling. Heat pumps can have different sources of heat. Examples are ground source, outdoor air source, ventilation air source, and water source HPs. The most common types in the Netherlands are ground source and outdoor air source heat pumps. Ground source HPs use underground heat as a source, while air source HPs use outside air as heat source⁵. All HPs share the same operational principle (figure 2.4). Low-quality heat from the heat source and electricity are used to generate high-quality heat used for heating purposes, commonly fed into a boiler system to supply heating and hot water. By using the available low-quality heat, the overall thermal heating power of a HP is a factor 2-5 higher than the electric input power (depending on the type of HP and the temperature of the source) [61]. This factor is known as the coefficient of performance (COP).

Heat pumps have a relatively high electric power. For individual homes, the power is often between 2 kW and 5 kW (sometimes HPs have an additional electric heater of up to 6 kW) [2]. When it is cold, the coincidence factor of HPs is high; many HPs in the same distribution network segment will run simultaneously, causing a significant additional peak load⁶.

An example of a pragmatic implementation of flexibility from HPs can be found in [62, 63]. Here, flexibility is obtained by adjusting the indoor temperature set-points. These set-point adjustments influence the operational state of the HP (on/off), shifting the load. Typically, user comfort is constraining the amount of flexibility HPs can provide. Other factors limiting the amount of flexibility HPs can provide are for example boiler size, heat capacity of a building, and level of insulation. End users want to keep their building heated at a comfortable level, which, based on these constraints, limits the amount of time HP loads can be shifted.

⁵When using HPs for cooling, the ground hole can be used to store heat or the outdoor air can be used to release heat into.

⁶Typically the average per household peak loading of Dutch households, observed at the medium-to-low voltage transformer, is around 1 kW-1.2 kW peak [2].

Cooling & freezer installations

Cooling & freezer installations, for example in warehouses, medical facilities and grocery stores, are a source of flexibility, typically connected to the distribution network. These thermostatically-controlled loads have a relatively large peak demand, and have the potential to shift their consumption in time by storing thermal energy in the installation.

An example is presented in [64], where medical freezers are participating in a flexibility scheme. The freezers are operated by an optimisation algorithm to demonstrate the benefits in terms of energy costs, efficiency and peak power reduction. Another example can be found in [65], where cooling and freezing installations at a wholesale-level food warehouse were controlled to minimise energy costs. The results in [65] show a potential cost reduction of 20%.

Other

Other sources of flexibility can for example be found in household appliances. Examples are a project in France has utilised flexibility from the electric heating in households by applying direct control [66]. The Nordic countries also recognise a significant flexibility potential for the electric heaters used. This is especially true for Norway, where electric heaters fulfil 70% of Norway's heating demand [67]. The flexibility potential of electric boilers is analysed by [68]. Another project in which electric boilers were used to provide flexibility can be found in [69]. The value of flexibility of residential loads such as laundry machines (so called white goods) has been analysed by [25]. These flexibility of such loads are, when the coincidence factor is taken into account, rather limited relative to the overall household consumption. This limited flexibility in household appliances is also found in [67]. Research on alternative sources of flexibility is ongoing. Many more examples can be found in literature.

2.5 Applications

Flexibility has different potential applications. DSOs mainly apply it for the purpose of congestion management, on which this thesis focuses. However, as it is important to be aware of other common applications, these are also discussed in this section: system balancing, energy arbitrage, portfolio optimisation, and connection capacity optimisation.

It should be noted that, although the applications are described separately, market parties can chose to offer flexibility for multiple purposes simultaneously, under the condition that the constraints of individual products are not

violated, as for example demonstrated in [70]. Examples are offering flexibility for balancing, while preventing congestion problems and participating in both system balancing and energy arbitrage [60]. This results in a challenge for market parties (i.e. aggregators), as they will need to optimise the commitment of flexibility for different applications.t

Congestion management

Flexibility for congestion management is a localised application, as network congestion is a location-specific phenomenon. Nevertheless, both DSOs and TSOs can apply congestion management and use flexibility to this end. This thesis focuses on congestion management for DSOs. Congestion management can be applied to prevent network reinforcements, to postpone network reinforcements, or to overcome the period it takes to do the reinforcements (the application the Dutch system operators and regulator are currently discussing [46]).

Congestion management can be implemented either as a boundary condition, in combination with another flexibility application (e.g. energy arbitrage while considering network limits as optimisation constraints [70]), or as a separate flexibility application. For the latter, DSOs need to actively obtain a flexibility product for congestion management. This is for example part of the market model of the universal smart energy framework (USEF) implementation [71, 72]. Both flexibility as a product and boundary condition require a suitable regulatory framework, which is currently being debated.

Flexibility for congestion management in principle can come from any flexibility source connected to the network, as long as it is in the same part of the network as where the congestion occurs. As overloading can cause harm to the network, or assets, DSOs require a level of certainty flexibility can reliably mitigate congestion. It is important to ensure this when selecting and designing a flexibility mechanism.

On a household appliance level, electric boilers [68] and heaters [66] have been used to provide peak load reductions. Congestion management through EV flexibility has been discussed by [73], evaluating different flexibility mechanisms (more on flexibility mechanisms in chapter 3).

In the context of this thesis, only network overloading is considered as a reason for applying congestion management. However, power quality problems like voltage violations can in some cases also be solved using local flexibility. For example, in the case of a LV feeder with a high amount of PV systems, the voltage at the end of the feeder might rise and exceed the power quality limits for voltage. Voltage control is typically done using reactive power or tap changers. However, reactive power has a limited influence on voltages in LV

feeders [74]. In LV feeders, flexibility might be an option for voltage control, by increasing the active power consumption to prevent an overvoltage [71].

The remainder of this thesis will discuss a number of practical challenges related to the application of flexibility for congestion management. This thesis focuses on congestion management from network overloading. However, some of the concepts might also be applied for voltage control.

System balancing

It is of paramount importance that supply and demand in the power system are in balance. The power system's balance can be determined by observing the frequency. An imbalance between supply and demand results in a frequency deviation [1]. When demand exceeds supply, the frequency drops and vice versa. In order to maintain a power system balance, TSOs rely on frequency containment reserves (FCR) and frequency restoration reserves (FRR) [20].

The frequency containment process, or primary control process, is an automatic process activated throughout the entire synchronous area ⁷, using droop control to stop frequency deviations. Once the frequency is stable, the TSO responsible for the area from which an imbalance originates activates (automatically or manually activated) FRR, to restore the system balance [20].

TSOs buy the necessary FCR and FRR from market parties. Traditionally, market parties offered these balancing products from the flexibility of conventional generation and large industrial and commercial loads. However, with the increasing share of electricity from wind turbines and PV, the amount of traditional generation (and with that traditional reserves) decreases. Therefore, flexibility from RES and demand-side flexibility (e.g. electric vehicles, battery energy storage) are increasingly offered as balancing products. Some examples can be found in [59, 75, 76, 77, 78].

In [75], a rule-based control strategy is proposed to maximise the self-consumption of households, using a combination of PV and battery energy storage. At the same time, the households participate in a virtual battery program, which participates with 1 MW in the FCR market.

A similar combination is made by [76], where flexibility from batteries and electric heaters is participating in the FCR market. Modulating the electric heaters decreases the battery degradation associated with the continuous charging/discharging in response to frequency deviations.

A combination of FCR and energy arbitrage using network connected battery energy storage, is proposed in [59]. A simulation is showing the suitability

⁷The Netherlands is part of the Continental European synchronous area.

and appropriate droop & arbitrage set-points to improve battery energy storage operations.

EVs are also able to participate in system balancing. EV participation in FCR is shown in a pilot project by [77]. Participation in automatically activated FRR is shown in a pilot by [78].

The application of flexibility for system balancing is important for maintaining the (future) power system's balance. The topic is extensively discussed in literature, and practical implementations have been made. However, flexibility for system balancing has other characteristics than flexibility for congestion management (e.g. balancing is less location dependent than congestion management). Lessons learned with system balancing can therefore not be directly applied for congestion management.

Energy arbitrage

Energy arbitrage is a way of trading energy, in which energy is bought when the price is low and sold when the price is high (for example on day-ahead and intraday markets). Flexibility from energy storage, for example in batteries, is a common way to achieve this. Examples of energy arbitrage through battery energy storage can be found in [59, 60, 79]. A combination of energy arbitrage and FCR is presented by [59], in which the current market prices are taken for energy arbitrage. Energy arbitrage and balancing services are also combined by [60], showing an improved power system resilience. Historical data is analysed and simulated for energy arbitrage use in [79].

An alternative flexibility source can be found in [70]. Here, EV smart charging is optimised, taking into account energy arbitrage and the distribution network costs.

Portfolio optimisation

Portfolio optimisation is a flexibility application for balance responsible parties (BRPs). BRPs provide (ex-ante) prognosis or energy programs to the TSO (see section 2.2), which the TSO uses to (ex-post) settle imbalance costs with the for the imbalance responsible BRP. Portfolio optimisation is a tool the BRP can use to to minimise deviations from the energy program and with that, the costs of an imbalance⁸.

⁸In some balancing areas (e.g. the Netherlands), BRPs are not penalised for imbalances/deviations from energy programs that are contributing in solving the overall system imbalance. In such situations, BRPs can explicitly chose to deviate from their program to solve a system imbalance: passive balancing [20].

Connection capacity optimisation

Taking the consumer perspective, the optimisation of the (contracted) connection capacity is an application of flexibility. In this application, flexibility is typically used for peak shaving. This can be used by consumers or end-users to reduce their peak load. This way, consumers can either prevent the need for a larger (more expensive) connection capacity due to that peak, or switch to a smaller (cheaper) connection capacity. Depending on the tariff structure, consumers can furthermore minimise the fee of power-based tariffs or penalty of bandwidth-tariff models (see section 3.2.2 for more information on tariffs).

In the HV network, connection capacity optimisation is used with a large-scale wind park in combination with battery energy storage. The battery storage is used to reduce the peak load of the wind park, thus feeding more continuously and with a lower peak into the network. It furthermore ensures the availability of electricity when there is no wind [57, 80].

A similar project has been piloted in a combination of large-scale PV with a battery energy storage [81]. The battery energy storage is used for a combination of peak shaving and FCR.

2.6 DSO perspective

So far, this chapter has discussed current developments related to flexibility in distribution networks. These developments all relate to DSOs and their operation of distribution networks. This section will reflect on that.

Potential flexibility sources discussed in this chapter, like EVs, BESSs, PV, HPs have a large impact on the distribution networks and therefore on DSOs. As discussed in section 2.4, high numbers of flexibility sources are connected to distribution networks and those flexibility sources often have a high load and coincidence factor (e.g. EVs, HPs). They are therefore both part of the cause of the DSO's congestion problem and part of the solution to it.

Additionally, the available flexibility can be used simultaneously for different applications (section 2.5). These applications can potentially conflict with DSOs' objectives (for example, system balancing requires an increase in load, while congestion management requires a reduction). Such possible conflicts are recognised in literature, although the way they are handled varies. Coordination between TSO and DSO, for example using a newly defined platform, could help solve such conflict. Some papers describe solutions in which the distribution networks are considered to be a constraint in the utilisation of flexibility for different applications, for example [70]. Other literature shows a conflict of interest can remain, leaving it to the market to be solved. USEF, for

example, leaves the possibility for such a conflict open, as can be found in the results of [69]. When considering flexibility in relation to the DSO, these developments should be taken into account. One way of doing that is enabling the DSO to activate a regime in which market parties are obliged to participate in mandatory congestion management, as is currently being debated in the Netherlands [46]. From the flexibility applications, congestion management is the most relevant for DSOs.

For congestion management, a planning phase and an operational phase can be distinguished. In the planning phase, DSOs need to decide whether flexibility can be a solution to congestion. Examples of flexibility in the planning phase can be found in [49, 82]. The impact of potential flexibility assets on distribution network loading can be found in [83]. Part of the planning phase is deciding on the mechanism that is to be implemented to unlock flexibility for congestion management. Examples of such mechanisms are tariff structures and flexibility markets. Chapter 3 elaborates further on different mechanisms to unlock flexibility, and how these mechanisms can be applied. The operational phase is about the day-to-day application of an existing flexibility mechanism/solution. There are many examples of this available in literature. In [84], system state estimation is used to predict day-ahead and intraday states, and estimate real-time states. Flexibility is then used to solve limit violations. In [85], an agent based real-time congestion management is proposed, including the incurred cost of overloading. In this thesis, aspects of the operational phase are touched upon in chapter 4, chapter 5, and chapter 6.

Just like the different flexibility applications can conflict with each other, sometimes different applications can complement each other. An example of this is connection capacity optimisation. By using flexibility for connection point optimisation, consumers or end-users reduce the peak load of the connection. This is interesting for DSOs, as their networks are designed to handle peak loads. Although the relation between peak load of customer and network is not one-to-one, wide-scale application of connection point optimisation might avoid congestion in distribution networks.

Under some circumstances, DSOs need to take power system balancing into account. This is especially the case when (parts of) distribution networks are operated in island (microgrid) mode. In [86], a frequency control strategy is proposed. This control strategy includes a virtual inertial frequency response, which is necessary due to the lack of significant amounts of rotating mass (or kinetic energy) in islanded systems⁹.

⁹The damping effects of the inertial frequency response on the rate of change of frequency slow down frequency deviations, providing FCR sufficient time to stabilise the frequency [20].

2.7 Conclusions

The research question answered with this chapter is: *What are current developments related to flexibility in the distribution networks, and which of these developments can DSOs make use of?* The current developments related to flexibility in distribution networks are discussed. This starts with the roles, of which the relatively new role of aggregator is important for the aggregation of available flexibility. Then, flexibility as a concept, including the definition used in this thesis, is discussed. For this thesis, flexibility is defined as the possibility to adjust power at a given moment in time for a given period at a specific location.

Next, this chapter elaborates on different flexibility sources commonly connected to distribution networks. These flexibility sources are not only able to provide flexibility, but also add a significant load to distribution networks. Especially the steep increase in numbers of EVs, HPs and PV systems can cause congestion in networks. These sources are therefore not only part of a solution to congestion, but are also part of the problem.

Then, possible applications of flexibility are discussed. These applications are congestion management, system balancing, energy arbitrage, portfolio optimisation and connection capacity optimisation. Some of the objectives of these applications are potentially in conflict (for example, system balancing could cause network congestion and solving a congestion could cause an imbalance), whereas others may be in agreement.

Congestion management is the main application of flexibility for DSOs, either for avoiding or postponing network reinforcements, or to overcome the time needed to complete network reinforcements. DSOs can however not ignore other applications, as the utilisation of flexibility for, for example, system balancing or energy arbitrage might conflict with the DSOs stakes (i.e. congestion management). There are however also applications that can be complementary with congestion management (e.g. connection capacity optimisation), as by minimising the connection capacity, network congestion is relieved as overall network peaks reduce.

3 | Flexibility mechanisms

3.1 Introduction

Chapter 2 introduced current developments related to flexibility in distribution networks. Different sources of flexibility have been identified, such as PV systems, EVs, HPs and BESS. Besides congestion management, alternative applications of flexibility have been discussed (e.g. system balancing, energy arbitrage) and possible conflicts between applications have been identified. Chapter 3 continues by introducing different mechanisms to make (local) flexibility available for day-to-day use by DSOs, including an overview of literature and example projects. The central research question of this chapter is: *Which different flexibility mechanisms can DSOs use to unlock flexibility in distribution networks?*

The remainder of this chapter is organised in the following sections: First, different flexibility mechanisms are examined. For each mechanism, a subsection with a concise literature overview is provided. This overview includes examples of projects in which the mechanism is applied. This is followed by a discussion on the mechanisms in relation to the DSO. Finally, the main conclusions are presented.

3.2 Flexibility mechanisms

In order to procure and employ flexibility in daily operation, flexibility mechanisms need to be selected and implemented. Flexibility mechanisms can be categorised in implicit and explicit mechanisms. Implicit flexibility mechanisms are also known as price-based mechanisms, while explicit mechanisms are also known as incentive-based mechanisms [87].

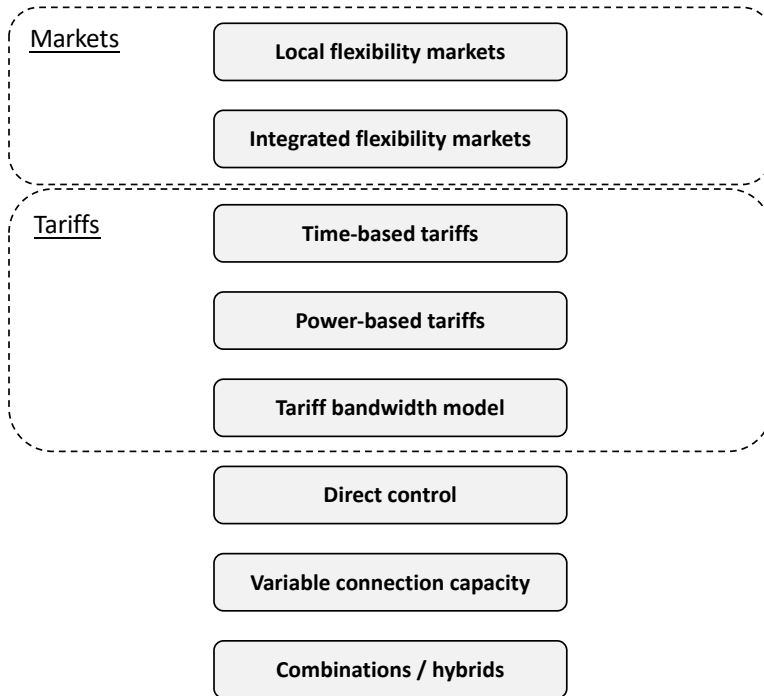

Figure 3.1: Overview of the flexibility mechanisms discussed in this chapter. The mechanisms 'markets' and 'tariffs' are divided in different subcategories.

The definitions of implicit and explicit flexibility mechanisms by [88] are adapted. Implicit flexibility is defined as the possibility of users to respond to price signals that reflect network and market variability. An example of an implicit flexibility mechanism is flexibility through tariff structures [89].

Explicit flexibility is defined as a commitment of demand-side flexibility, traded on one or more markets (e.g. balancing markets). An example of an explicit flexibility mechanism is a flexibility market [89], providing a product for (e.g.) congestion management¹.

When implementing a flexibility mechanism for congestion management, DSOs can choose between different (implicit and explicit) mechanisms. In this section, a literature overview is provided for a number of (commonly applied)

¹The definition of flexibility products for congestion management depends on the market definition and can for example be capacity- or energy-based.

mechanisms: flexibility markets, tariff structures, direct control, variable connection capacity, and combinations of different mechanisms. An overview of the mechanisms and their subcategories can be found in figure 3.1. The different flexibility mechanisms are widely researched. Many more articles and examples can be found in literature. The concise overview presented in this section is however sufficient to provide the necessary background for the remainder of this thesis.

3.2.1 Flexibility markets

Flexibility markets are a market-based approach to unlock flexibility. Flexibility markets are a form of explicit flexibility, as flexibility for congestion management is defined as an explicit product that a DSO can purchase. Two main types of markets can be distinguished: local and integrated flexibility markets. These markets can operate ahead-of-time (e.g. day-ahead or intraday) or near real-time. Additionally, flexibility markets can be supplemented with bilateral agreements between the DSO and (some) aggregators, to ensure DSOs that sufficient flexibility is available.

Local flexibility markets

Local flexibility markets are operated locally, offering the DSO that is active in an area flexibility for (typically) congestion management. Such a flexibility market has multiple sellers (aggregators) and a single buyer (the DSO). Local flexibility markets can coexist with wholesale or centralised markets. An example is the universal smart energy framework (USEF), a framework which offers congestion management to DSOs while providing the aggregator the possibility to also trade with BRPs or TSOs [71].

Integrated flexibility markets

Integrated flexibility markets are markets that provide a market platform, on different flexibility services for (for example) DSOs, TSOs and market parties (e.g. BRPs) are integrated in a single market. An example of a centralised, integrated market is GOPACS (Grid Operator Platform for Congestion Solutions), which integrates a flexibility market into an existing intraday market (ETPA) [90].

An alternative to a flexibility market with an explicit flexibility product for congestion management, is an integrated market in which network constraints are implicitly taken into account. Such coupled market is proposed by [91].

In the proposed coupled market, a local market platform is introduced to facilitate flexibility source participation in wholesale and balancing markets. The local market then takes the distribution network constraints into account during the clearing process, effectively preventing congestion.

Projects

Flexibility markets are a popular research topic, both in academic literature and in industry-oriented pilots. To illustrate different possible implementations, a number of projects and practical implementations are introduced. Other examples can be found in literature.

Villar et al. [92] discuss flexibility market designs, differentiating between short- and long-term flexibility products. Furthermore, different market roles and their interactions are taken into consideration. This results in a literature overview of various flexibility market related publications, differentiating between academic and industrial literature [92]. Villar et al. conclude that a number of important challenges still need to be resolved, namely that it is needed to: further standardise flexibility products and services², define a new set of system services related to congestion management, decide whether to use existing or new markets (and whether to do this local or not), and decide how to remunerate flexibility products.

Olivella-Rosell et al. focus on local flexibility markets and identify the main criteria such market should fulfil [93]:

- Provide flexibility for congestion management to DSOs;
- Provide payment to market parties (e.g. BRPs and aggregators);
- Ensure flexibility provision does not compromise consumers or prosumers needs for electricity.

Olivella-Rosell et al. furthermore introduce a flexibility market framework, which is used in two H2020 projects: EMPOWER and INVADE [93, 94, 95]. The EMPOWER project focuses primarily on providing a market framework to enable prosumers to provide flexibility for network management purposes, while the INVADE project uses this framework to integrate EVs and BESSs into the distribution networks. Olivella-Rosell et al. have shown that the proposed flexibility market framework can be applied from a technical perspective, but that market economic profitability remains an open question [93].

²The variations in traded flexibility products and entry requirements are also applicable to the projects discussed in the remainder of this section, making this open challenge relevant for those examples as well.

Olivella-Rosell furthermore concludes that without extensive information from end-users, aggregators are only able to provide flexibility for congestion management, without the possibility to optimise their portfolio for multiple applications [95].

A Dutch project with an USEF-based local flexibility market is Energiekopllopers (Energy frontrunners), taking place in the city of Heerhugowaard. An aggregator traded (day-ahead and intraday) flexibility with both DSO and/or BRP, taking user preferences into account. The project has shown that the DSO can use a flexibility market for congestion management, both technically and commercially. It however also shows conflicts of interest exist between the BRP's need of portfolio optimisation and the DSO's need of congestion management [69]. This is in line with a finding of [96], which states interactions between different stakeholders are inevitable in order to achieve the highest overall benefits for the power system [96].

The H2020 InterFlex project introduces different market models in various demonstration sites. The flexibility models in the InterFlex project differentiate between bilateral agreements between DSO and aggregator and (open) market trading [97]. The InterFlex project shows combinations of both are needed to reach the full potential of flexibility, while identifying the lack of a common market definition and sufficient liquidity as bottlenecks.

Schittekatte and Meeus identify six flexibility market design controversies and discuss those controversies in relation to a case study of four (operational) European flexibility market implementations [98]. The first project is an UK based project, using Piclo Flex as a platform to enable DSOs to procure flexibility. The second project called Enera operates in Germany, which has as main goal to utilise (demand-side) flexibility to avoid wind curtailment. The third project is the Dutch GOPACS, which integrates a flexibility market in an already existing intraday market. The fourth project NODES is based in Norway and enables BRPs and system operators to procure flexibility in an intraday timeframe. Based on the case study, Schittekatte and Meeus conclude two trends are among the important factors of success for these markets. The identified trends are TSO-DSOs cooperation and third party market operators [98].

Piclo, GOPACS and Enera are also discussed in [99], alongside the H2020 DOMINOES project. The H2020 DOMINOES project focuses on an interoperable market structure, enabling active consumers to participate in flexibility provision [99]. Koreneff et al. presents an analysis of local flexibility market, and is written in the context of the Finnish Smart Otaniemi project. Smart Otaniemi is an ongoing project in Espoo, Finland. In this project, many different pilot projects related to for example flexibility are clustered in a single platform [100, 101].

3.2.2 Tariff structures

Flexibility through network tariff structures is considered an implicit method to unlock flexibility. Changes in tariff structures have a long term impact. It therefore will take time to determine whether changes have the desired effect on network loading at the location and on the time flexibility would be needed. In the Netherlands, the network tariff structure is one out of four components determining the overall price of electricity. The other three components are the cost of supplying electricity, a metering fee, and taxes [89]. The four components are explained point by point:

- *Network tariffs* are related to a customer's connection capacity, distribution and transmission of electricity, and system services.
- *Metering costs* reflect the costs of installing, maintaining, measuring, and reading the metering values. In the Netherlands, the DSO provides metering services to retail consumers, while large consumers need to contract a separate metering company [102].
- *Supply costs* are determined by the energy supplier and depend on the price of electricity on the market, the trading behaviour, the profit margins of suppliers, and the pricing scheme that is used.
- *Taxes* break down in two components: a fixed tax per kWh and a VAT levied on all costs.

The limited share of the network tariffs on the overall price is illustrated by a breakdown of the electricity price for retail consumers (connections up to 3x80 A). A retail consumer's total price of electricity breaks down in approximately 40% for the supply costs, 40% for taxes, and 20% for the (combined) network tariff and metering fee [103].

The usage of different tariff structures to unlock flexibility by changing consumption behaviour is extensively studied [104, 105]. Consumers are exposed to tariffs. Changing the tariff changes the total price of electricity and correspondingly consumers' behaviour. In [104] it is found that the consumers' changes in behaviour vary from modest to substantial, which depended on the available enablers, technology, and data. Hu et al. identifies barriers limiting flexibility through tariff structures, three of which are: consumers typically being exposed to fixed retail prices, utilities not having enough incentives to promote flexibility among their customers, and the lack of harmonised methods to evaluate flexibility delivered as a result of tariff changes [105].

Time-based tariff structures

Time-based tariff structures are most commonly discussed in literature. Time-based tariffs set a price per unit of consumed energy (e.g. €/kWh). Hu et al. discuss four time-based tariffs: time-of-use, real-time pricing, critical peak pricing, and peak time rebates [105]. These same four tariff structures are analysed by [106].

- *Time-of-use* tariffs are higher during peak periods and lower in off-peak periods. Time-of-use depends on the moment in time consumption takes place and sets a fixed price for each period.
- *Critical peak pricing* is an addition to flat tariffs or time-of-use tariffs. Critical peak pricing adds a surcharge during moments of (extreme) peak loading. The surcharge is typically restricted to a limited amount of hours per year. As critical peak pricing is based on the network's peak load, its frequency of occurrence might not be the same for different locations in the network. This might be difficult to combine with the European regulatory framework, requiring location independent tariffs.
- *Real-time pricing* is (for example) based on the price of electricity on (wholesale) markets. The price of electricity can be determined either real-time or ahead-of-time (e.g. day-ahead)³.
- *Peak time rebates* is a compensation fee consumers receive for reducing their demand during periods of the day. According to Hu et al., peak time rebates are less common than the other three tariff structures [105].

In addition to the four above-mentioned tariff structures, Eid et al. discusses interruptible capacity programs and emergency demand response [106]. In interruptible capacity programs, loads are interrupted voluntarily in return for a rebate. In the case of emergency demand response, load interruptions are mandatory and non-compliance is penalised.

Power-based tariff structures

Alternatives to volumetric, time-based tariff structures are power-based tariff structures, introducing a tariff component linked to a consumer's power level. Power-based tariffs are extensively researched and taken into use by some DSOs and customer groups in Finland as an alternative to the energy based

³Real-time pricing also has a potential risk: [107] has shown real-time pricing can lead to a systematically higher energy bill.

price per unit of energy (both with or without time-of-use component). As a result of energy efficiency and self-consumption of local production, the revenue of the DSO is reduced while the costs remain. One solution is increasing the energy-based tariffs. Rautiainen et al. however argues that increasing the energy-based tariff would affect customer equality, as price differences among customers grow (high versus low volumetric use) even though their peak load (for which the network is designed) might be the same [108]. As an alternative to the current tariff structure, therefore four power-based tariff structures are considered [108, 109]:

- A *power tariff*, consisting of three cost components: a fixed fee (e.g. €/month), an energy-based fee (e.g. €/kWh), and a power charge (€/kW), based on the peak power.
- A *threshold power tariff*, consisting of three cost components: a fixed fee, an energy based fee and a power exceeding fee (€/kW). The power exceeding fee is only charged when a predetermined threshold is exceeded.
- A *power limit tariff* or *power band tariff*, for which the consumer contracts a maximum power and commits to not exceeding this contracted power. In case of a breach of contract, the consumer either pays a surcharge, or switches to a larger power band (and the corresponding higher base fee).
- A *step tariff*, consisting of two cost components: a fixed fee and a consumption-related fee (€/kWh). The consumption related fee increases with steps, and depends on the average consumption over an hour in relation to a predetermined value.

Tariff bandwidth model

Since recently, in the Netherlands another tariff structure is under research: the tariff bandwidth model [103]. This model relates loosely to the power-based tariff structures (in particular the power limit tariff) under investigation in Finland.

Three variations of the bandwidth model are proposed, namely a static bandwidth model, variable bandwidth model, and variable aggregator bandwidth model [103]:

- *Static bandwidth tariff*. Within the static bandwidth tariff, consumers contract a static, predetermined bandwidth smaller than the physical

connection capacity. If the consumer exceeds the bandwidth (instantaneously or averaged over an hour or PTU, depending on the implementation), the DSO calculates a surcharge per kWh. This tariff structure is in line with the power limit tariff.

- *Variable bandwidth tariff.* The variable bandwidth model adds a location- and time-dependent component to the static bandwidth tariff, linking the bandwidth to the load of the transformer. This results in location-dependent tariff differentiation, for which appropriate regulation and political- and societal support are required. The transformer load is divided in three steps: low, middle and high load. A low transformer load results in a larger bandwidth and vice versa. Consumers will be informed about the amount of bandwidth per timestep ahead-of-time.
- *Variable aggregator bandwidth tariff.* Within the variable aggregator bandwidth tariff, aggregators are allowed to cluster the bandwidth of their consumers to an aggregated total. The DSO charges the aggregator with a surcharge only when the aggregated bandwidth is exceeded. In order for an aggregated bandwidth tariff to work, aggregators and DSOs need to communicate about the location in the network for which the bandwidth is specified, such that the aggregator knows which customers are involved. To facilitate this, appropriate ICT systems are required.

Projects

In the Dutch pilot *Jouw Energie Moment* (Your Energy Moment), both real-time pricing and critical peak pricing have been applied. The pilot focused on household flexibility, implementing an energy management system and smart appliances (e.g. laundry machines). The pilot showed that as a result of price awareness, consumers are willing to shift their energy consumption with lower prices [110, 111]. In practice, it might however be challenging to generate sufficient financial benefits for customers, when automation and communication costs are taken into account.

The Finnish research program related to power-based tariffs aims to find alternative tariff structures, to ensure future tariffs keep reflecting DSOs costs. Rautiainen et al. present an overview of advantages and disadvantages of the different power-based tariffs and analyse a numerical case study of an urban distribution network consisting of primarily households [108]. The differences in DSOs revenues are computed, showing the potential applicability of these tariff structures. Additional analyses are presented by Lummi et al., demon-

strating power tariffs and threshold power tariffs to be the most suitable candidate tariff structures [109].

3.2.3 Direct control

Direct control is a mechanism that provides a DSO with the ability to directly influence/control a consumer's point of connection (PoC) or a consumer's appliances behind the meter.

Direct control appears to be commonly applied in combination with thermostatically controlled loads, such as water heaters and air conditioning systems. Direct control as a flexibility mechanism is extensively discussed in literature. This section will discuss a number of recent publications applying direct control on thermostatically controlled loads.

Erdoğan et al. discuss direct control in the context of residential heating, ventilation and air conditioning systems [112]. An incentive mechanism is proposed, in order to motivate consumers to participate in a flexibility program. Consumers are given incentives with free energy credits, depending on their participation's performance. These credits can be used outside the time-window in which direct control is applied (for example, when energy prices are high). The proposed strategy is compared to a stochastic reference profile, representing the consumer's behaviour in case no direct control would be applied. It was found that the proposed direct control method leads to reductions in consumer's operational costs.

Tang et al. propose another direct control strategy for air conditioning systems. A method is proposed to take user comfort preferences into account. Two algorithms are proposed by [113], a genetic algorithm and a (simpler) empirical algorithm. Related to this work, [114] adds a methodology to select which air conditioning units participate in response to a flexibility request, taking the air conditioning's operating states into account. This is compared with the current situation in Hong Kong, in which the DSO directly controls air conditioners, without taking operating states (and thus the user needs) into account. It is shown that with the proposed methodology, for both the empirical and genetic algorithm, significant improvements can be made in terms of user comfort, while maintaining the ability to provide the required amount of flexibility to the DSO [113, 114].

An alternative research direction can be found in the acceptance of direct control by consumers. It is shown in [115] that a residential consumer's acceptance is higher for thermostatic loads, PV systems and batteries compared to household appliances (e.g. washing machines and dish washers) and EVs, which have a lower consumer acceptance.

Projects

An example in which direct control is applied within a large project can be found in NiceGrid (part of the Grid4EU project). NiceGrid tests an islanding situation in case of an emergency in the higher-level power system. Part of the required flexibility or power for islanding situations comes from battery systems. For part of the required flexibility, the DSO uses direct control to turn off residential heaters in order to reduce the peak load and prevent network overloading [66]. In this example, the DSO uses direct control as a last resort or emergency regime, to prevent a large-scale power outage.

Outside Europe, a case-study of an existing implementation of direct control in Egypt is presented in [116]. In this example, the DSO's current practice is randomly shutting down parts of the distribution network. The paper researches a method for the local DSO to contract consumers to participate in a direct control program in order to reduce the load during the peak period. The advantages of this method over random shut-downs are demonstrated.

3.2.4 Variable connection capacity

The flexibility mechanism *variable connection capacity* is a mechanism on the point of connection (PoC) between consumer and DSO. It takes a number of advantages from (alternative) tariff structures and direct control, setting a capacity limit on the point of connection. It however does not intervene with appliances connected behind the PoC. The variable connection capacity could be used as a mechanism to facilitate a non-firm connection contract, a contract form which is currently under debate.

Variable connection capacity can be used to reduce the expected peak loads of distribution networks. The consumer's connection capacity is changed from a flat capacity limit to a variable capacity profile, making the (contracted) connection capacity time-dependent. DSOs can enforce this based on contractual agreements, and can verify consumer compliance using measurement data.

Four parameters can be distinguished: the off- and on-peak capacity, start of the on-peak period, and the duration of the on-peak period (e.g. number of hours). Figure 3.2 illustrates the concept of the variable connection capacity and its related parameters from the perspective of the PoC. During the on-peak period, the connection capacity at the PoC is reduced to the on-peak capacity.

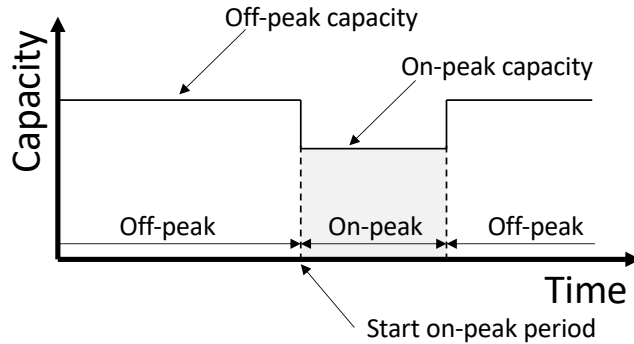

Figure 3.2: Illustration of the variable connection capacity concept and its related parameters.

Predefined and dynamic capacity profiles

A variable connection capacity can be implemented in different ways. Two options are the application of a predefined capacity profile on the PoC and the application of a dynamic capacity profile on the PoC.

When applying a predefined profile per day, the period of capacity reduction and the time of the start of capacity reduction are fixed to a predefined period of the day (e.g. the daily peak load period). An advantage of a predefined capacity profile is that it can be implemented without requiring ICT infrastructure of customers and DSOs to communicate in order to get the profile to the customer. For a predefined capacity profile, a local ICT solution at the customer is sufficient. For a predefined profile, a contractual agreement between DSO and consumer, specifying the capacity reduction for each day, is sufficient. The lack of operational control is a disadvantage of a predefined capacity profile. This is in particular relevant when peak loads occur during different periods of the day. In that case a predefined capacity profile might no longer provide the required flexibility.

An alternative is applying a dynamic capacity profile, which can be altered on a daily basis. For the application of a dynamic capacity profile, the starting time of the on-peak period is determined based on the operational flexibility needs and the profile is then communicated ahead-of-time (e.g. day-ahead). This way, the start of the on-peak period is matched with distribution network's expected peak load. This is an advantage for the dynamic capacity profile. As a consequence (and disadvantage), information about the capacity profile needs to be communicated between DSO and PoC, requiring additional ICT infrastructure and decision-making capabilities.

Non-discriminatory

For the dynamic capacity profile, the duration of the on-peak period can also be made variable. This is for example possible up to a predetermined maximum period per day. DSOs are however required to provide customers with non-discriminatory connections and contracts. A variable duration will conflict with that non-discriminatory requirement, if some customers are limited more frequently than others. A similar situation might arise if DSOs offer different customers predefined capacity profiles with variations in the duration of the on-peak period.

On the other hand, a non-discriminatory connection might be guaranteed by adding an additional parameter: the cumulative time of on-peak periods (e.g. hours per year). In that case, DSOs can set on-peak periods in capacity profiles for a predetermined cumulative time. DSOs can then decide on the moments and duration at which flexibility is necessary, and set on-peak periods during those moments. This way, on-peak periods and network congestion are matched as much as possible, which adds an advantage to this flexibility mechanism.

The decision to set on-peak periods at a certain moment and for a certain period however, becomes more complicated, as DSOs then need to not only estimate congestion in their network ahead-of-time, but have to take the behaviour of individual PoCs in their network into account as well. An example: assume a congestion problem is expected in the first quarter of the year. The DSO now has to decide whether to use a part of the allowed cumulative time of on-peak periods, or whether to save it for another time later in the year, with a potentially higher need. Furthermore, to remain non-discriminatory, DSOs might have to ensure the contracted reductions are executed throughout the year, without deviating from this agreement. This additional complexity is disadvantageous in comparison to a dynamic profile per day, for which the operational complexity is smaller.

Projects

In the Netherlands, a DSO has done a pilot with a variable connection capacity mechanism. The variable connection capacity was used to prevent (simultaneous) charging of (large numbers of) EVs during the distribution network's peak load. The DSO offered consumers a dynamic variable connection capacity for the tariff of the on-peak capacity. During on-peak hours, the capacity of the EV charging is limited, preventing an additional contribution to the distribution network's peak. During off-peak hours, EV charging had additional

capacity available, during which EV charging could be scheduled. The project has shown that without any additional financial incentives, this mechanism improves both the business case of EV charging and prevents an additional peak load on the distribution network. However, due to the legislation regarding non-discriminatory connections, the DSO could not offer the variable connection capacity to customers beyond the scope of the pilot [54].

3.2.5 Combinations and hybrids, and others

As part of the research on (among others) congestion management, DSOs and TSOs have been working on active system management (ASM). ASM provides DSOs and TSOs with a set of tools and strategies to operate the power system in a cost-effective and secure manner [117]. Market-, tariff-, and connection-based mechanisms, such as discussed throughout section 3.2 can be considered in the context of ASM. Two additional mechanisms are however also identified: technical and rule-based strategies. With technical strategies, the topology of networks is adjusted to change power flows and system states, while rule-based strategies can for example be used to curtail assets in order to guarantee compliance with technical and regulatory requirements [117].

An alternative to a single flexibility mechanism is applying combinations or hybrid forms of multiple mechanisms. This is for example possible for combinations of flexibility markets and variable connection capacities, and direct control in combination with flexibility markets or tariff structures. However, when multiple mechanisms are combined or integrated in hybrid forms, it is necessary to align the mechanism's time lines (e.g. dynamic tariffs should be known before the gate-closure of flexibility markets). When available flexibility is used/offered for multiple applications, alignment is also needed (e.g. knowing the tariffs before participating in energy arbitrage).

A variable connection capacity can be combined with flexibility markets, especially in case a predefined capacity profile is defined. In that case, consumers can offer their flexibility on the market, taking the off-peak and on-peak capacity into account as constraints while trading. This combination can also be made applying a dynamic capacity profile. This however requires communication and alignment of multiple mechanisms (i.e. the dynamic capacity profile should be available before flexibility is offered on flexibility markets). An example of a project in which the variable connection capacity is conceptually aligned with a flexibility market is the Dutch demonstrator of the H2020 InterFlex project, where the communication of the dynamic capacity profiles are scheduled well before the gate-closure of the local flexibility market [52, 118].

Haque et al. propose a strategy combining direct control with indirect

control, effectively combining a direct control mechanism with a tariff structure [119]. An agent-based architecture is proposed. The DSO procures day-ahead load reductions through an aggregator by iterating dynamic price and corresponding household load profiles between aggregator, household and individual appliances. When an aggregator is unable to provide the required load reductions, a direct control mechanism is automatically triggered.

An example of a hybrid implementation can be found in the description of USEF [71]. As part of the local flexibility market design, the framework proposes four operating regimes: normal operation, capacity management, graceful degradation, and power outage. Conceptually, the flexibility market providing a congestion management product to DSOs takes place in the capacity management regime. If at any point in time no flexibility is offered or available, the distribution network would risk an outage (the power outage regime). This is the regime that should be avoided, as a power outage results in outage minutes for customers. USEF defines an intermediate regime called graceful degradation. In the graceful degradation regime, the DSO (autonomously) applies direct control on loads and generation, with the objective to prevent a(n) (wider-spread) outage. It is up to the DSO to decide when to switch from normal operation to capacity management (in case congestion is expected and the DSO requests flexibility from the market), and from capacity management to graceful degradation (for example because the market failed to offer flexibility). Whether or not, and how DSOs is penalised for switching to graceful degradation is a political and societal decision, which needs to be embedded in the regulatory framework.

3.3 DSO perspective

So far, this section has elaborated on various mechanisms to unlock flexibility. These mechanisms are not exclusive for unlocking flexibility for congestion management, but can also be used for other flexibility applications. This section reflects on the methods from a DSO perspective, with an emphasis on congestion management in distribution networks.

DSOs need to prevent congestion in their networks and flexibility provides the potential to do so. However, for flexibility to be an alternative to network reinforcements or a method to overcome the time needed to realise network reinforcements, DSOs need a degree of certainty that flexibility is also available when - and on the location - they need it. The flexibility should furthermore be available for a longer period of time (for example, the time needed to realise network reinforcements) and at an attractive price, such that DSOs can request it when congestion is expected.

Flexibility markets are a widely researched mechanism to unlock flexibility. In these markets, DSOs define an explicit flexibility product to prevent congestion and buy it from market parties. In an open market, where market parties put in bids, market liquidity is a condition to ensure healthy competition and prices, and to ensure the required degree of certainty that flexibility will be available.

An open market is challenging to implement in LV networks, in particular for LV feeders, as the amount of flexibility sources connected (thus the amount of aggregators) to these networks are limited. For MV networks, these numbers are larger and might be able to provide sufficient flexibility sources and market parties. As discussed, DSOs need a degree of certainty that (reliable) flexibility is available for congestion management. Whereas the availability of flexibility in LV networks is limited, the larger number of flexibility sources present in MV networks might provide sufficient degrees of certainty for DSOs to use an open market, depending on the location in the MV network.

As an alternative, DSOs can procure (part of the) flexibility through (long-term) bilateral contracts with aggregators or customers. This mitigates (part of) the risk of no flexibility being available or the requested prices being too high to compete with network reinforcements. A boundary condition for this flexibility to be available at the right location is exchanging location information between DSO and aggregators and/or customers.

If flexibility through flexibility markets does not provide the desired levels of flexibility (i.e. insufficient certainty of availability or insufficient reliability in supply), DSOs can implement direct control as a fall-back solution. Currently, the collective Dutch network operators and the Dutch regulator (Dutch: Autoriteit Consument & Markt) are in the process of redefining the regulatory framework. This enables DSOs to use direct control as a fall-back regime, in which customers are obliged to participate in congestion management when the network is facing imminent congestion [46]. Adequate ICT systems and regulation to support this need to be implemented.

Implicit mechanisms like flexibility through tariff structures or variable connection capacities offer DSOs with possibilities to unlock flexibility in both LV and MV networks. Research has shown consumers are willing to shift (part of their) flexible loads (e.g. [25]). However, DSOs are still unaware whether participating consumers have flexibility available behind these mechanisms. An additional challenge with in particular tariff structures is the relatively small share the tariff has in the (retail) consumer's overall electricity price.

3.4 Conclusions

The research question answered with this chapter is: *Which different flexibility mechanisms can DSOs use to unlock flexibility in distribution networks?* Four different flexibility mechanisms DSOs can use to unlock flexibility are discussed: flexibility markets, tariff structures, direct control and variable connection capacities. For the flexibility mechanisms 'flexibility markets' and 'tariff structures', a number of subcategories are considered. Each mechanism and its main characteristics are explained.

Flexibility markets can be distinguished in local and integrated flexibility markets, where local markets typically coexist with wholesale markets and integrated markets combine both local and wholesale-level aspects.

Tariff structures distinguish in time-based, power-based and tariff bandwidth structures. Until recently, time-based tariffs were most discussed in literature. Existing tariff structures often do not reflect the costs of the network anymore. Therefore, alternative methods are investigated (e.g. power based tariffs in Finland and tariff bandwidth models in the Netherlands).

After elaborating on four different flexibility mechanisms, possible combinations and hybrids of mechanisms are discussed. In order to enable the combination of mechanisms to complement each other, it is necessary to align the mechanism's time lines (e.g. for a combination of tariffs and markets, ensure that consumers and aggregators are aware of dynamic tariff profiles before flexibility market bids are submitted). This alignment is also relevant when available flexibility is used/offered for multiple applications (e.g. a tariff structure for DSOs and flexibility for energy arbitrage).

Regardless of the chosen mechanism, it is for the DSO imperative that the required level of certainty and reliability are maintained to guarantee security of supply. One way of guaranteeing this is by implementing a mandatory fall-back regime, in which the DSO can use direct control to mitigate imminent congestion. Flexibility should furthermore be offered at competing prices and the long-term availability should be guaranteed, in order to be a realistic alternative to network reinforcements.

4 | Case study

4.1 Introduction

Chapters 2 and 3 discussed various concepts related to flexibility as a concept, its sources and applications, and mechanisms to unlock flexibility. Chapter 3 evaluated both literature and practical implementations. Chapter 4 discusses a case study, related to the thesis work discussed in the chapter 5. The sub-question answered in chapter 4 is: *Which insights can be derived from a specific demonstration project, for the benefit of every-day deployment of flexibility by DSOs?*

The remainder of this chapter is organised in the following sections: First, the Dutch sub-project of the H2020 InterFlex project and its demonstrator is introduced and the insights from this demonstration project are discussed. The implementation and demonstrator of the Dutch InterFlex sub-project and the contents of this thesis are strongly related. After discussing the InterFlex sub-project, a number of other (follow-up) developments are briefly discussed. Finally, the conclusions are summarised.

4.2 InterFlex: Dutch sub-project

The European funded H2020 InterFlex project investigates different methods in which flexibility can be used for the needs of DSOs [120]. The project has been active between 2017 and 2019. The InterFlex project is split into several pilot sites (or sub-projects), one of which is the Dutch sub-project.

The Dutch InterFlex sub-project investigates how a DSO can use flexibility for congestion management to maintain a cost-effective network infrastructure. The sub-project focuses on both a technical implementation of flexibility for congestion management purposes and the implementation of a business layer

to enable the DSO to procure flexibility from market parties. This is done by introducing a (local) flexibility market. Aggregators can offer their flexibility to this market, the DSO procures the necessary flexibility from the market [121]. The local flexibility market with the DSO as a single-buyer is within the scope of the sub-project. Market trading between aggregators and other market parties is allowed, without giving the DSO priority to flexibility. Whether aggregators choose to do so is up to them and is therefore not analysed in the sub-project.

4.2.1 Project description

This section will briefly discuss the sub-project's goal, base assumptions, location, and used flexibility sources.

Goal

The Dutch InterFlex sub-project has four main goals, defined in [121]. These goals can be summarised as:

- *Utilisation of flexibility for network management purposes.* Within the sub-project, flexibility is primarily utilised for congestion management. In the design process, a future extension for voltage control is however taken into account.
- *Design and implementation of a business model for flexibility trading.* The implementation in this sub-project explicitly goes beyond a technology showcase. Therefore, one of the goals is to analyse and describe the relevant roles and their interactions (including value exchange).
- *Design and implementation of an open flexibility market.* In order to facilitate an open market in which multiple aggregators can compete and offer their respective flexibility to one (or more) DSO(s), existing market structures and standards (such as the universal smart energy framework or the open charge point interface) are used as the basis for the design and implementation of the local flexibility market.
- *Ensure scalability of the designed and implemented solution and architecture.* In order to ensure a broad usability of the developed solution, all relevant stakeholders are involved in the project and a clear separation of roles in the system is made. By designing the sub-project in this way, the architecture and business model can continue to exist, and be further developed and applied on a larger scale beyond the lifetime of the pilot.

Base assumptions

A number of base assumptions are made at the start of the sub-project. These assumptions are as follows:

- *Fixed pilot location.* The pilot location of the Dutch InterFlex sub-project, the locations (both physically and in the distribution network) and the types of flexibility sources are selected before the start of the project. Measurement equipment is present in the pilot location's distribution network.
- *No real congestion is expected.* On the pilot location, the distribution network is not physically congested. Congestion management is applied, using a virtual congestion limit. Exceeding this limit has no negative impact on the physical network.
- *Open local flexibility market.* An open, local flexibility market is used to apply congestion management. Market parties are allowed to trade on the local flexibility market and on other markets. There is no obligation to provide flexibility to the DSO in case of expected congestion.
- *Congestion management limited to ahead-of-time domain.* In case the market cannot solve expected congestion, this congestion will not be solved in a different way. Since the physical distribution network will not be overloaded, there is no fall-back mechanism in the (near) real-time domain. For real-life application, such (near) real-time fall-back mechanism is needed. Currently, there are discussions related to the application of direct control ongoing in order to facilitate this (see section 4.3, under 'direct control').

Pilot location

The pilot location of the Dutch InterFlex sub-project can be found in Eindhoven. Eindhoven is the fifth largest city of the Netherlands and is part of an industrialised, high-tech region (Brainport Eindhoven). The municipality stimulates and facilitates innovative initiatives. One of the areas of the city in which such innovative initiatives are clustered is Strijp-S. Strijp-S is a former industrial complex, which is now home to a wide variety of start-ups, cultural communities, and housing. Strijp-S is an urban environment and has an area of approximately 0.3 km² [121]. The number of inhabitants increased from a few hundred in 2013 to approximately 1700 by 2020 [122].



Figure 4.1: Geographic overview of the pilot location.

The pilot site is centred around three apartment buildings ('Blok 59', 'Blok 61', and 'Blok 63') and a parking garage 'Sporzone' (figure 4.1). These apartment buildings include 156, 96 and 102 apartments respectively [118].

Flexibility sources

Three types of flexibility sources are applied in the Dutch InterFlex sub-project, namely electric vehicle charge points (EVCPs), a central battery energy storage system (BESS), and a controllable solar PV installation [118, 121]:

- *EVCPs:* Thirteen EV charge poles will be installed. Each charge pole has space for two EVs, resulting in 26 EVCPs. The capacity on the PoC of each charge pole is 3x63 A.
- *BESS:* The BESS is a centralised battery, installed in a 20 ft container. The energetic capacity of the BESS is 315 kWh and the maximum in-

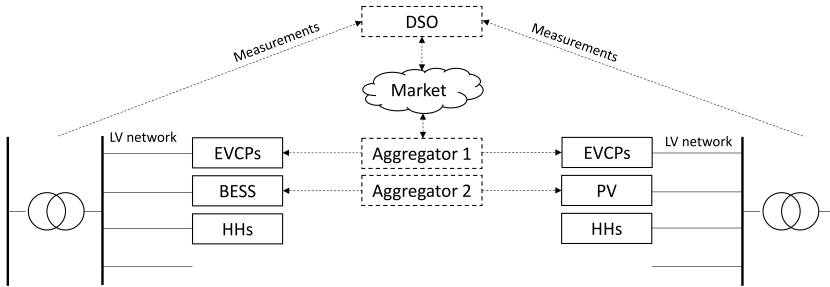

Figure 4.2: Overview of the pilot implementation. The following abbreviations are used: DSO – distribution system operator, EVCPs – electric vehicle charge points, BESS – battery energy storage system, PV – photovoltaic, HHs – households.

verter power is 255 kVA. The BESS has a passive (LCL) filter to control the harmonics. The connection capacity at the PoC is 3×250 A (approximately 173 kVA).

- *PV system:* An existing PV system on the Strijp-S area is included in the pilot. The orientation of the PV panels can be controlled remotely, thus adjusting the output power of the installation. The total power of the PV system is virtually scaled (or increased) to represent a larger installation.

4.2.2 Pilot design

This section will introduce the design of the pilot. A simplified overview of the pilot setup is provided in figure 4.2. The figure illustrates that the DSO interacts with two aggregators to obtain flexibility through a market. The aggregators control the flexibility assets behind the two congestion points: medium-to-low voltage (MV/LV) transformers. The base (or inflexible) loads connected to the congestion points are primarily represented by households.

The remainder of this section will elaborate on the following aspects of the pilot design. First, the flexibility market implementation and underlying roles and interactions are discussed. Then, the protocols used are reviewed and finally the network topology is introduced. Additionally, the smart grid architectural model (SGAM) of the Dutch InterFlex sub-project can be found in appendix B. The tools DSOs need to make decisions on every-day deployment of flexibility (e.g. forecasting, decision-making) are discussed in chapter 5.

Flexibility market

The Dutch InterFlex sub-project uses a local flexibility market, on which aggregators offer flexibility for congestion management purposes. This market is a single-buyer market. Aggregators are not obliged to offer available flexibility exclusively on the local flexibility market, but are allowed to maximise their profit by offering flexibility on other markets (e.g. wholesale markets, balancing markets, or as portfolio optimisation products).

Conceptually, the flexibility market is designed to facilitate a day-ahead and an intraday stage. However, within the sub-project, the flexibility market implementation primarily focuses on day-ahead flexibility requests. Flexibility can be requested per program time unit (PTU), for (blocks of) multiple (consecutive) PTUs, and is defined in kWh/PTU. The PTUs are of the same duration as the PTUs, or imbalance settlement periods, of the Dutch balancing market: fifteen minutes. The gate closure time of the day-ahead flexibility market is aligned with the gate closure time of the wholesale day-ahead market (i.e. the flexibility market gate-closure is before the wholesale day-ahead market gate closure).

The local flexibility market mostly follows the universal smart energy framework (USEF, see [71, 72]). The participating (commercial) aggregators provide the DSO daily (before the gate-closure time) with (obligatory) prognoses of their flexibility sources' schedules, such that the DSO can take these loads into account when evaluating potential congestion and a resulting flexibility need. The DSO then sends out a flexibility request. The flexibility request contains the location for which flexibility is needed, the amount of flexibility per PTU (and with that implicitly the time and duration), and (specifically for this pilot) the maximum price the DSO is willing to pay, sanction price, and available power (see paragraph on 'interfaces and protocols' for more information on these pilot-specific attributes). The aggregators can reply with a flexibility offer, specifying amount of flexibility per PTU and the price of flexibility. The DSO evaluates the offers based on the prices and decides which offer to accept, if any¹. USEF facilitates a multi-cycle negotiation phase between DSO and aggregator, to request and offer flexibility before gate-closure. To prevent this multi-cycle negotiation from completing before the flexibility market's gate closure time, a single-cycle mechanism in which the DSO only sends a single flexibility request is proposed. This is achieved by including an extra attribute

¹In this pilot, it is possible the DSO chooses to allow an overloading rather than obtaining flexibility. This can for example occur when the overloading is relatively limited and the cost of lifetime reduction of a component due to overloading is smaller than the price of flexibility. See chapter 5 for the rationale.

in USEF to communicate the available power on the distribution network during non-congested PTUs.

Roles and interactions

The pilot implementation distinguishes three explicit roles: distribution system operator, commercial aggregator (CA), and local aggregator (LA). The DSO determines where and when flexibility is necessary and sends a request to the CAs active on the local flexibility market, who in turn unlock flexibility through the contracted LAs.

The pilot implementation explicitly distinguishes between the roles of commercial and local aggregator. During market consultations at the beginning of the pilot, it was recognised that some aggregators focus on the technology integration, offering the unlocked flexibility to market parties (i.e. local aggregator). Other aggregators (typically aggregator/BRP combinations) focused on flexibility trading, not developing the technology to unlock flexibility themselves (i.e. commercial aggregator). And another group of aggregators combined trading and technology integration. The InterFlex sub-project chooses to define these roles independently, to give market parties the freedom to either specialise on a single role, or combine multiple roles in one.

The CA's role is defined as *"a demand service provider that combines multiple short-duration flexibility sources for sale or auction in organised energy markets."* [121]. Examples of markets on which CAs can be active are balancing markets, wholesale markets, and (local) flexibility markets.

The LA has the responsibility *"to collect and bundle (geographically) local flexibility into a bigger aggregated flexibility offering, and to provide this to a commercial aggregator."* [121]. The LA does this by contracting and/or maintaining (local) flexibility sources. In relation to EVs, the LA role is also known as charge point operator (whereas, considering the overview of roles in section 2.2, EV drivers/customers of the charge point operator are 'consumers').

Each of the three roles have their own system to participate and interface with the local flexibility market. The DSO has a grid management system (GMS), the commercial aggregators have a flexibility aggregation platform (FAP), and the local aggregator a local infrastructure management system (LIMS):

- *Grid management system:* The DSO uses the GMS to determine the amount of required flexibility for each congestion point in the distribution network. Based on the flexibility need, the GMS is used to request flexibility from the CAs active on the local flexibility market. Steegh et

al. elaborates on the generic implementation of the GMS [123], introducing its framework. The tools that are needed to procure flexibility in a day-to-day setting are part of the GMS and discussed in chapter 5 of this thesis.

- *Flexibility aggregation platform:* The FAP is the front-end system interfacing with the DSO's GMS and with the LA's LIMS on the one hand, and the CA's internal trading and portfolio optimisation systems on the other hand. The CA does not necessarily exclusively trade flexibility on the local flexibility market and might therefore have additional interfaces with BRPs, wholesale-, and balancing markets. Ran et al. elaborate on a generic implementation made for the InterFlex sub-project [124].
- *Local infrastructure management system:* The goal of the LIMS is to standardise the interface between LA and CA. This is important for scalability, as the communication with flexibility sources is not standardised, and many flexibility sources use proprietary protocols. By standardising the communication and information exchange between LA and CA (see SGAM, appendix B), the interface between LA and CA becomes technology agnostic with regard to underlying flexibility sources. To include new types of flexibility sources, LAs only need to alter the interface between flexibility source and LIMS.

The interfaces and/or protocols between systems are standardised to improve scalability.

Figure 4.3 provides a schematic overview of roles, systems, and interactions. Within the pilot implementation, two CAs and two LAs are participating, operating the flexibility sources in the field, and trading with this flexibility on the energy markets. Each CA interfaces with a single LA. One CA/LA combination focuses on EV charging, while the other CA/LA combination focuses on flexibility from PV and BESS.

Interfaces and protocols

Scalability is one of the goals of the sub-project. Therefore, the interfaces between DSO and commercial aggregator, and between commercial and local aggregator should be as much standardised as possible. The closest fits are USEF and the energy flexibility interface (EFI, for more information see [125]) for the DSO/commercial aggregator and commercial/local aggregator interfaces respectively [121]. On the interface towards the local EV aggregator, the open charge point interface (OCPI) protocol is used [126]. For USEF and

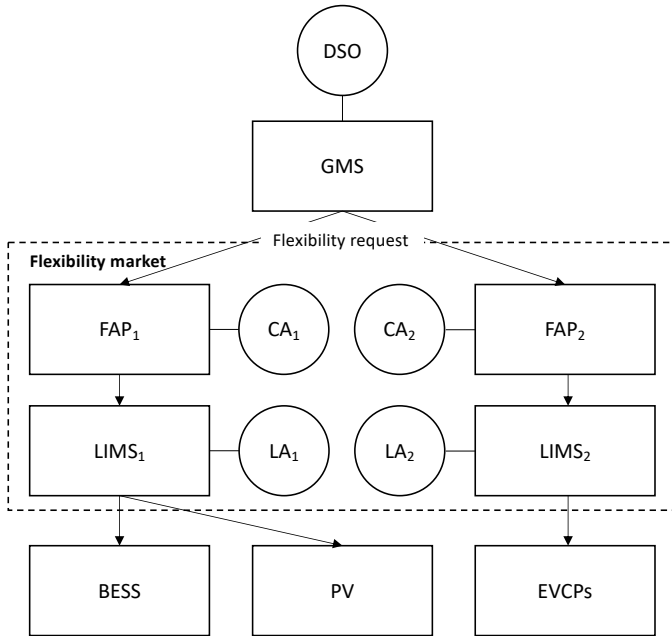

Figure 4.3: Overview of the roles, systems, and interactions in the pilot implementations. The following abbreviations are used: DSO - distribution system operator (role), GMS - grid management system (system), FAP - flexibility aggregation platform (system), CA - commercial aggregator (role), LIMS - local infrastructure management system (system), LA - local aggregator (role), BESS - battery energy storage system (system), PV - photovoltaic (system), EVCPs - electric vehicle charge points (system).

EFI, some adjustments were necessary. The protocols used between the various interfaces and systems are visualised in appendix B, figure B.3. In order to clarify the use of an adjusted protocol, the markers USEF+ and EFI+ are used instead of USEF and EFI. The adjustments in USEF and EFI are discussed in [123, 127]. Two examples of adjustments made in USEF are:

- *Sanction price:* The aggregator receives a sanction when unable to deliver contracted flexibility. Within the sub-project, the sanction price is added to USEF. This price is a variable the DSO and aggregator set for a particular (ahead-of-time) flexibility order. Additionally, the DSO also provides the maximum price for which it is willing to obtain flex-

ibility. This prevents an aggregator from sending offers that are too expensive [127, 128].

- *Available power:* The DSO adds another two attributes to its communication with the market: the minimum and maximum power available. This is the difference between the rated transformer power and the expected (forecasted) loading of the transformer, in both load and supply directions. This enables the negotiation process between DSO and CA to be limited to a single-cycle. The DSO sends a flexibility request to the CA, stating the PTUs in which flexibility is required and the available power (bidirectional, minimum and maximum) during the non-congested PTUs. The DSO's flexibility request and CA's reply (flexibility offer) can be exchanged in a single-cycle, before gate closure of the flexibility market, as by knowing the available power, aggregators are aware to which PTUs loads can be shifted without causing congestion at a different moment in time [123]. USEF recognised the value of these attributes and included them in the specification of the USEF flexibility trading protocol (UFTP) [129].

Network topology

Dutch MV distribution networks are typically designed as a ring, connecting various MV/LV substations. A normally open point (NOP) is added to each ring, effectively operating the MV networks radially [2]. This principle is illustrated in figure 4.4. The pilot is concentrated around two consecutive 630 kVA MV/LV transformers (substations). These transformers are the pilot's congestion points. The MV ring and the substations' outgoing LV feeders are not considered as congestion points. Since no physical congestion occurs on the two transformers, a (lower) virtual congestion limit, or virtual rated transformer capacity, is assumed.

On both congestion points, two aggregators are active in parallel, offering flexibility from a centralised battery energy storage system (BESS) with a capacity of 173 kW and 315 kWh energy storage [55], and 26 electric vehicle charge points (EVCPs) of 22 kW each. Furthermore, a solar PV installation is managed by one of the aggregators. The inflexible loads consist of 354 households (apartments), various small enterprises, a parking garage, and some public streetlights. All loads are connected to the LV network, and divided over the two 630 kVA MV/LV transformers, which each have eight outgoing LV feeders. Figure 4.5 visualises the congestion points and their underlying loads.

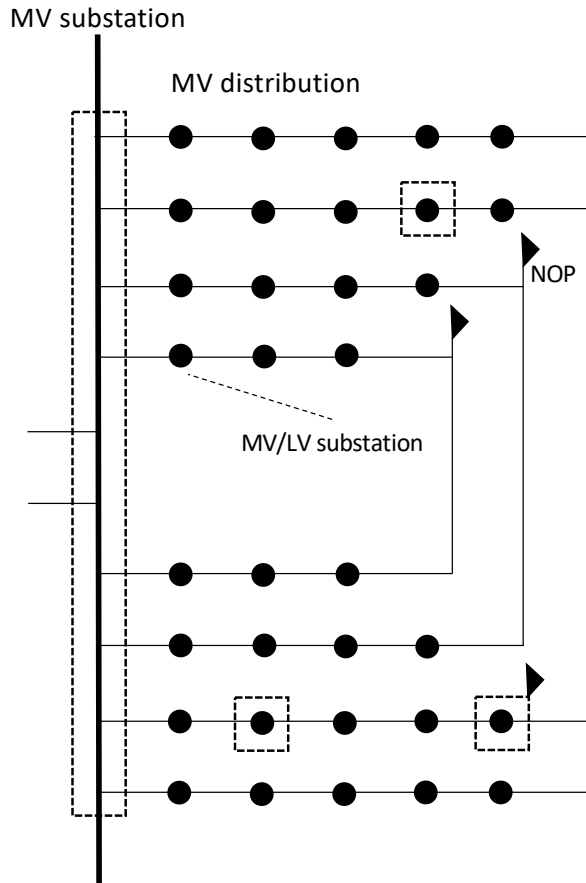

Figure 4.4: Typical example of MV distribution rings with normally open point (NOP) during operation.

Measurement equipment is installed on the MV ring and on all outgoing feeders of the MV/LV substations. The measurement equipment automatically sends 15-minute averaged measurement values of [121, 130]:

- Phase voltage (all phases to neutral);
- Phase currents (all phases);
- Active power (per phase and total);
- Reactive power (per phase and total);
- Energy (bi-directional);
- THD (per phase current).

4.2.3 Insights from the demonstrator

This section summarises the main insights from the demonstrator, as published by the Dutch InterFlex sub-project in deliverable D7.6 [131] and deliverable D7.7 [126]. Section 4.2.4 will reflect on the insights from the demonstrator.

System architecture and protocols

The InterFlex sub-project explicitly defined separate roles and responsibilities for the DSO, commercial aggregators, and local aggregators. Each role is connected to a corresponding system, respectively the grid management system (GMS), flexibility aggregation platform, and local infrastructure management system. The interfaces between the systems make use of predefined protocols. The experience with and the results of the pilot have shown that this separation of roles and responsibilities worked well, enabling the actors fulfilling the roles to focus on their core business and competences. Due to scalability and interoperability, the sub-project aimed at using open protocols on the interfaces between systems. This was not always possible without making adjustments. Further standardisation of these interfaces on an international level is therefore advised.

In particular USEF is more than a protocol on the interface between DSO and commercial aggregator. Part of USEF is a framework that describes a local flexibility market model, which supports trading of flexibility for different purposes (among which congestion management) [71]. Additionally, USEF specifies information and message exchanges (see the SGAM information layer

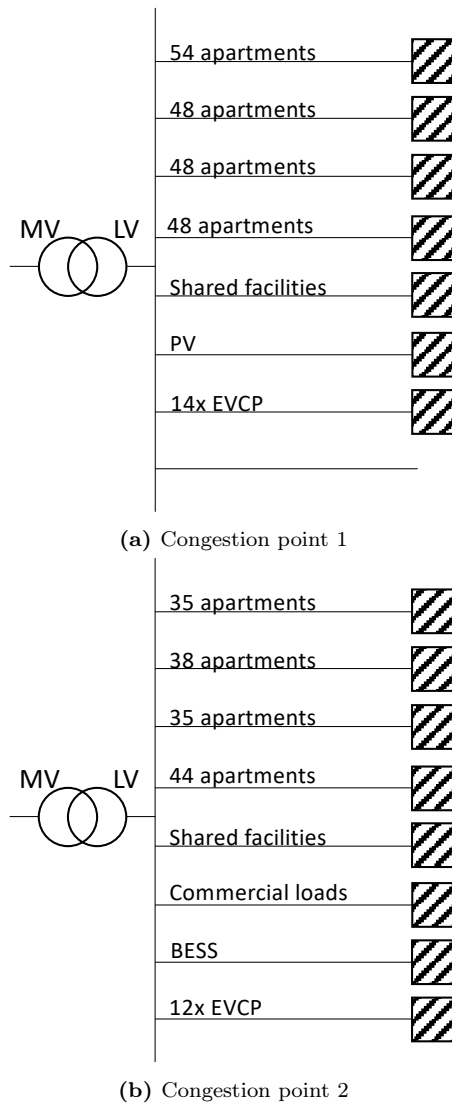

Figure 4.5: High-level topology of congestion points (MV/LV transformer) and their outgoing feeders. The types of connections/loads are indicated per feeder. The feeders 'Shared facilities' connect the loads of the apartment building (e.g. elevators). The used abbreviations are PV (photo-voltaic), BESS (battery energy storage system) and EVCP (electric vehicle charge point).

in appendix B). It however does not prescribe all the required communication and information exchanges, which parties involved need to agree upon themselves. This results in (for scalability undesired) case-specific variations. Furthermore, the sub-project had to make some changes in the message exchanges. For scalability and interoperability USEF needed to be improved further, preferably splitting the market model and the message exchanges (including prescribed implementation) to minimise its complexity. This has been recognised by the USEF foundation. An update of the framework is published in May 2021 [72] and a message exchange protocol UFTP is introduced [129].

The DSO specifically had to build a GMS in order to operationalise flexibility. The GMS had to be designed and implemented and needs to contain the tools the DSO needs to operationalise its flexibility needs. This includes among others a load forecasting algorithm and a means of decision-making regarding to the location, duration and amount of desired flexibility. The work related to the operationalisation of flexibility in the context of the GMS is included in this thesis and discussed in chapter 5.

Smart charging

One of the InterFlex sub-project's flexibility sources is the EV, by applying smart charging. Not all EV drivers participate in a smart charging program, and in order to be able to use smart charging flexibility as a congestion management product, EV drivers needed to register with the aggregator active in the area. This last boundary condition has proven a challenge and for future projects it is important to provide participants sufficient incentives and actively recruit EV drivers to participate. This is however out of scope for both the InterFlex sub-project and this thesis (see section 1.3). Geelen et al. analysed the customer satisfaction of those EV drivers who participated in smart charging and showed these EV drivers were willing to participate and were generally satisfied with the financial compensation they received for participation [132].

Approximately 15% of all EV charging sessions was a smart charging session with the aggregator active in the area. These sessions could potentially be used to participate in the local flexibility market. The availability of flexibility from EV charging is hard to predict (and therefore an open challenge identified in section 2.4), which gets complicated further by a relative low share. The possibilities for EV flexibility to solve congestion were, in this sub-project, therefore limited. On top of that, the sub-project has experienced rebound effects from shifting EV loads to different timeslots, introducing new peaks and/or shifting congestion in time. The newly introduced congestion then

has to be solved once again, introducing additional costs for the DSO. This might be mitigated or avoided by changing the design or incentives within the demonstrator.

Flexibility availability

In the context of this sub-project, flexibility from PV curtailment and flexibility provided by the BESS system have proven to be relatively reliable in terms of delivering flexibility (respectively 90% and 100% of the ordered flexibility is delivered by PV and the BESS, whereas EV smart charging could only deliver flexibility in 30% of the times the DSO ordered flexibility [126]). The DSO could procure the flexibility when needed and the prognoses regarding these flexibility sources' (future) behaviour were relatively accurate compared to flexibility from EV. On the other hand, the price of these sources was also higher than the price of flexibility from EV [126]. This suggests that the ability to deliver flexibility with a high degree of certainty is part of an aggregator's value proposition.

For flexibility to be a viable alternative to network reinforcements, DSOs need sufficient certainty cost-effective flexibility is available when its needed. Furthermore, flexibility that has been requested needs to be delivered in a reliable manner. The InterFlex sub-project has evaluated this on MV/LV transformer level. As only two market parties participated in the market, this resulted in a limited market with limited liquidity. It is therefore recommended to evaluate alternative market models, for example using long-term bilateral contracts between DSO and aggregators. Furthermore, it is recommended to evaluate the potential of flexibility through an open (local) market on MV level, where more assets are available and the market's liquidity is potentially larger.

Baselining flexibility

Within the sub-project, settlement of delivered flexibility is done by comparing a baseline with measurements. A rudimentary implementation facilitating settlement is included in the sub-project, in which the DSO and aggregator exchange information on flexibility source measurements. The baseline is based on USEF's D-prognoses², for which the sub-project identified a risk of gaming (when a DSO has a structural problem, a market party can learn the DSO

²D-prognoses are part of USEF. Aggregators send these prognoses day-ahead to the DSO, who uses the prognoses to determine where/when congestion occurs and to settle delivered flexibility after it has been delivered. See [71] for more information on D-prognoses.

frequently requests flexibility during certain timeslots and artificially increase the D-prognoses, forcing the DSO to purchase more flexibility). The measurements are furthermore not independently evaluated, enabling manipulation of both data and the settlement process. The project points out the necessity for further research to define an improved settlement process, with an initial focus on the baseline. This thesis will analyse the baselining challenge more in-depth in chapter 6.

4.2.4 Reflection

This section will reflect on the insights from the Dutch InterFlex sub-project, summarised in section 4.2.3.

The insights from the Dutch InterFlex sub-project show an open market does not always ensure certainty in the availability of flexibility at a competitive price. The sub-project has operated a local flexibility market in LV distribution networks. Flexibility from EV has proven to be challenging to forecast in LV networks. Limited customer (EV driver) engagement in smart charging reinforced this finding. The limited market liquidity increases the prices of flexibility for the more reliable flexibility sources (i.e. BESS and PV). The results from the sub-project suggest operating an open flexibility market on MV/LV transformer level or below exposes DSOs to the risk when necessary flexibility is unavailable or the costs of flexibility are not competitive with network reinforcements. Further research should analyse whether open flexibility markets in LV networks are feasible in general.

During the sub-project, flexibility from BESS and PV was able to provide more reliably in the flexibility needs of the DSO. This observation might be caused by the fact that PV and BESS are relatively easy to control and are not affected by end-user behaviour (unlike EV). It might furthermore be the case that participating aggregators had their own learning in this pilot, possibly focusing their operation strategy primarily on congestion management rather than other flexibility markets (in particular balancing markets). As these analysis were not in scope of the InterFlex sub-project, and aggregator participation and profit maximisation are out of scope for this thesis (see section 1.3), further research should analyse the aggregator operation strategies and the business case of flexibility for (in particular) BESS systems.

It is expected that the accuracy of forecasting flexibility availability from EVs will increase with larger numbers of EVs (e.g. for congestion management in MV networks). However, to have sufficient liquidity in an open flexibility market, it is necessary that multiple parties compete in such open flexibility market. In case larger numbers of EVs are spread out over multiple market

parties, it once again becomes relevant to forecast the available flexibility per market party. To mitigate this uncertainty, market parties could for example diversify their portfolio or different market parties active in a market all focus on a single flexibility source, but ensure they have all available sources under their control.

Within the sub-project, the DSO relies on the local flexibility market to solve congestion problems. The sub-project does not include a fall-back mechanism (this is out of scope [128]), in case the market fails. Due to the certainty DSOs need to ensure security of supply when applying flexibility for congestion management, it is however recommended for the DSO to implement such fall-back mechanism. As a substitute of, or in addition to an open market, DSOs can apply alternative (implementations of) flexibility mechanisms. Discussions between system operators and the regulator and developments in follow-up projects consider these possibilities (see section 4.3).

Another of the sub-project's insights relates to scalability and interoperability of the system architecture and protocols on the interface between DSOs and market parties. Within the sub-project a grid management system (GMS) is developed. This system is tailored to the needs within the sub-project. This system needs to be standardised further to facilitate large-scale application of flexibility in distribution networks. The same applies to the protocols and interfaces between DSOs and market parties. The sub-project uses USEF, which at the time the demonstrator was developed, did not standardise the implementation of the SGAM communication and information layers. It is recommended to standardise the way the communication and information is exchanged between DSO and aggregator/customer. This interface is preferably the same for all (Dutch) system operators. These insights from the demonstrator have been shared with the USEF foundation and taken into account in the May 2021 update of USEF [72] and the message exchange protocol UFTP [129].

Besides standardisation of the GMS as a system, DSOs should consider how to integrate flexibility for congestion management in their organisation and processes. In other words: which part of their organisation is the user of a GMS. Traditionally, DSOs have network planning and operational departments (among others). The network planning department plans distribution networks on a medium-long term, the operational department (or control centre) operates the distribution networks (near-)real-time. When applying flexibility for congestion management on a large scale, on a short-term basis, network loads need to be forecasted, it must be assessed whether congestion is expected and if so, appropriate measures must be taken ahead-of-time (e.g. day-ahead). This processes needs to be secured within DSOs organisation, for example by expanding the scope of the operational department to include ahead-of-time flexibility actions.

4.3 Other developments

The InterFlex sub-project officially ended in December 2019. The sub-project facilitated the DSO to make significant steps in researching and implementing tools to enable day-to-day flexibility utilisation. There are however still a number of research directions the DSO wants to further evaluate. Therefore, the DSO defined three pilot projects to follow up on the InterFlex sub-project. The pilots focus on long-term bilateral capacity contracts, a centralised flexibility market in collaboration with TSO and other DSOs, and direct control of decentralised generation (specifically PV).

The follow-up projects furthermore address one of the main recommendations for future research resulting from the Dutch InterFlex sub-project, namely settlement. The InterFlex sub-project demonstrated a rudimentary implementation for the settlement of delivered flexibility, applying a baseline. The pilots on bilateral contracts and a centralised flexibility market, discussed in this section both need a settlement methodology and use a baseline. Part of the scope of both projects is designing and implementing a baselining methodology, however the exact design and implementation is not yet clear.

In parallel, the Dutch system operators and regulator are currently redefining the regulatory framework regarding congestion management (as discussed in section 3.3), in which long-term bilateral contracts (both capacity and redispatch contracts) and flexibility through intraday redispatch are considered as market mechanisms, and direct control could be a mechanism for the mandatory non-market based fallback option [46]. This section will briefly discuss the ongoing developments in these three pilots.

Bilateral contracts

One of the pilot projects following the Dutch InterFlex sub-project is the project 'Experimenten Verzwaren Tenzij' (EVT, English: experiments reinforcing, unless). In this project, the DSO experiments with flexibility as an alternative to reinforcements and gains experience with long-term bilateral capacity contracts. The DSO contracts an aggregator (based on a tender procedure) to provide flexibility in a network for which (future) congestion as a result of feed-in by PV systems is expected. The aggregator in turn contracts (local) customers to provide the flexibility. The GMS developed in the Dutch InterFlex sub-project is further improved, to enable to DSO to adequately forecast congestion and communicate the flexibility needs to the aggregator. For the EVT project, the flexibility need is communicated day-ahead. Long-term bilateral capacity contracts provide the DSO with the desired certainty that sufficient flexibility is available.

Centralised flexibility market

A joint project in which TSO and DSOs collaborate is GOPACS. GOPACS is a centralised flexibility market platform used to mitigate congestion. GOPACS currently collaborates with the ETPA intraday market, but expects to interface with additional markets (e.g. EPEX and NordPool) in the future [133]. In order to maintain the overall system balance, the flexibility product traded on GOPACS' market is a(n) (intraday) redispatch product, meaning that every activated flexibility order is countered with a second flexibility order in opposing direction [133]. The GOPACS platform verifies this redispatch does not cause congestion in other parts of the power system [134]. In addition to an open intraday redispatch market, DSOs can increase the certainty of available flexibility (for a fair price) using long-term bilateral redispatch contracts.

Direct control

DSOs in the Netherlands developed a pilot setup to experiment with PV curtailment. By curtailing a small amount of peak power, the DSOs expect to facilitate up to 30% additional generation with the existing distribution networks [135]. This is a mechanism already applied in a broader context in Belgium and Germany [136]. One of the challenges is the development of a real-time interface (hardware and communication/protocols) to enable the DSO to directly control a (large) PV system's output power. The collective Dutch system operators are currently in the process of developing a standardised system for this real-time direct control interface [136]. This interface could potentially also be used for mandatory non-market based congestion management solutions or for real-time interventions when ahead-of-time mechanisms fail. This gives DSOs the level of certainty they need when applying flexibility solutions.

4.4 Conclusions

The research question answered with this chapter is: *Which insights can be derived from a specific demonstration project, for the benefit of every-day deployment of flexibility by DSOs?* The case study focused on the Dutch InterFlex sub-project, in which a local flexibility market was designed. This local flexibility market provided an open market platform on which the DSO could procure flexibility from aggregators, to solve network congestion. Within the sub-project, the roles and systems are clearly separated and defined and the interfaces standardised as much as possible to guarantee scalability and interoperability. From the sub-project it became apparent that further standardis-

ation is necessary, as the existing protocols were not (yet) directly applicable. Based on the insights of the InterFlex sub-project, some proposed adaptations have now been included into USEF and UFTP.

One of the challenges the DSO faced, was building a system to provide the tools with which flexibility can be procured in an every-day operational environment. This is done by developing a grid management system (GMS), in which forecast and decision-making algorithms result in flexibility procurement. The work described in chapter 5 of this thesis discusses the operational tools implemented in the GMS. Further development and standardisation of a GMS and securing the every-day operational flex procurement in the DSO's organisation and processes is recommended, to enable large-scale application of flexibility for congestion management.

For DSOs, two of the major drawbacks of an open flexibility market are the lack of certainty that sufficient flexibility will be offered, and (in markets with relatively few market parties) the potentially high prices market parties can ask (e.g. due to limited liquidity). Within the Dutch InterFlex sub-project this became clear through the uncertainty of EVs being available for smart charging on the one hand, and the price of flexibility from more reliable sources (e.g. BESS or PV curtailment) being relatively higher. DSOs therefore need to investigate alternative flexibility mechanisms. It is recommended to implement a fall-back mechanism, which DSOs can use in case their primary flexibility mechanisms (e.g. market-based flexibility) fail. This furthermore mitigates the (additional) risk DSOs face when aggregators focus on alternative flexibility markets, in case a flexibility market for congestion management is not sufficiently attractive.

Three alternative (variations of) flexibility mechanisms are investigated in pilot projects following the Dutch InterFlex sub-project. The related pilots research flexibility through long-term bilateral capacity contracts, a centralised flexibility market in which TSO and different DSOs participate and flexibility through direct control. These developments are in line with the ongoing discussions between Dutch system operators and the Dutch regulator, who are in the process of redefining the regulatory framework related to congestion management. The expected regulatory changes increase the importance of gaining experience with these flexibility solutions in pilot context.

One of the main recommendations for future work from the InterFlex sub-project, and one of the challenges needing a solution for EVT and GOPACS, is the settlement challenge. DSOs need a methodology to settle delivered flexibility (ex-post). This is an ongoing challenge in practical flexibility implementations to which no reliable solution has been implemented yet. This thesis contributes to the challenges related to baselining (chapter 6).

5 | Operationalising flexibility

5.1 Introduction

So far, this thesis described the different flexibility sources and their applications in the power system (chapter 2), the mechanisms that can be utilised to unlock the required flexibility (chapter 3), and a case study (chapter 4). Based on the knowledge the DSO now has, a choice for a suitable flexibility mechanism can be made for each of the DSO's use cases. The next step, after implementing that mechanism in the field, is using flexibility in daily operation.

The central research question in chapter 5 is *What tools do DSOs need to make decisions on the every-day deployment of flexibility for network-support, and how can DSOs apply these tools?* This chapter addresses the tools the DSO needs to make decisions on the day-to-day deployment of flexibility for network-support, and elaborates on how to apply these tools. In other words: we discuss the operationalisation of the DSO's flexibility needs. This operationalisation is defined as *the day-to-day (operational) decisions as to where, when, and how much flexibility is needed*. This is the operational phase after the implementation of any particular (chosen) implicit or explicit flexibility mechanism. The DSO therefore knows the location in the network that is

This chapter is based on:

R. Fonteijn, P.H. Nguyen, J. Morren, J.G. Slootweg. Demonstrating a generic four-step approach for applying flexibility for congestion management in daily operation, *Sustainable Energy Grids and Networks*, 23, 2020.

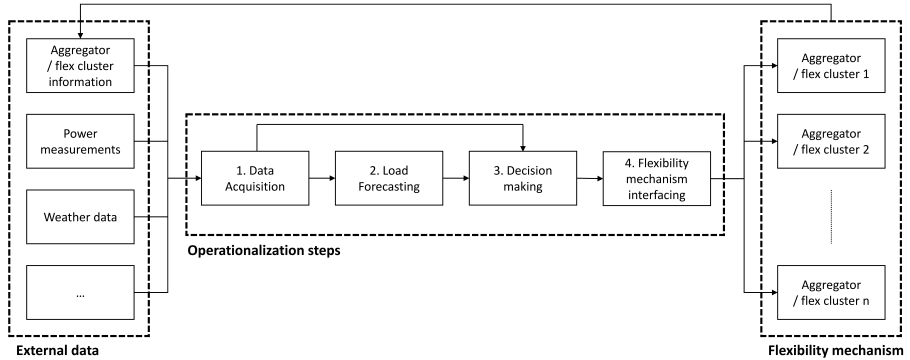

Figure 5.1: Steps to operationalise flexibility for DSO application.

congested. This location is known as a congestion point. This chapter focuses on explicit mechanisms, but nonetheless reflects on system design choices for implicit mechanisms.

5.2 Operationalisation of the flexibility need

After selecting and implementing a mechanism to unlock flexibility in the field (e.g. a flexibility market), the DSO needs to make day-to-day (operational) decisions as where and when flexibility needs to be applied, and (in case of a market) at which cost (the method to set the pricing is determined by the DSO, and implemented as part of the day-to-day decisions). This decision-making in daily operation is defined as the operationalisation of flexibility, and includes all the day-to-day operational decisions the DSO needs to make in order to obtain the necessary flexibility from the flexibility mechanism. The operationalisation of flexibility consists of four steps (see figure 5.1):

1. Data acquisition;
2. Load forecasting;
3. Decision-making;
4. Flexibility mechanism interfacing.

Figure 5.1 visualises the relation between the external factors (input data and the flexibility mechanism in place), and the DSO's system. The data is

primarily used in the (short-term) load forecast; however, for specific implementations additional data can also be needed in the decision-making model (for example weather data). The remainder of this section briefly explains the individual steps, after which section 5.3 provides further details.

To determine the need for flexibility, DSOs need to know (or predict) the current or future power flows through their network and its components (e.g. the transformer and/or cable loading). DSOs install measurement equipment to obtain necessary measurements from their network, and combine this with external data sources such as weather data.

Using this data, a load forecast can be made for the various distribution network components (e.g. transformers, cables). Typically, this is a short-term load forecast, ranging from week-ahead to near real-time, depending on the flexibility mechanism applied.

The error and uncertainty in the forecast lead to uncertain congestion scenarios on the basis of which the DSO needs to make a decision regarding the location and amount of needed flexibility. Depending on the implemented flexibility mechanism, additional choices (e.g. market price or value of flexibility in case of a flexibility market) can be made.

The interface between the DSO's forecasting and decision systems, and the systems of external parties (e.g. aggregators, households, industry) which offer the flexibility needs to be defined. This interface is dependent on the implemented flexibility mechanism (e.g. tariffs, market). The interface translates the flexibility need to the specific mechanism in place and interacts with the systems of (multiple) external actors involved in the provision of flexibility. Since the interface needs to be mechanism-specific (in some cases even case-specific), it is evaluated as an individual step in the operationalisation process

5.3 A four-step approach for flexibility operation

5.3.1 Step 1. Data acquisition

In order to gain insights into the loading of the distribution network, and in an attempt to manage this more efficiently, DSOs are collecting increasing amounts of data. This data comes from measurements in the distribution network itself (e.g. voltage, current), on transformer and low voltage (LV) feeders, and connection (e.g. smart meter) level. The relevant parameters for congestion management are active and reactive power, which the measurement

equipment computes from the voltage and current measurements. The time-resolution of these measurements can differ, but would typically at least be aligned with the market windows in which trading is done (e.g. 15-minutes or hourly measurements).

Besides the data from measurement devices, data from external sources can be used. This can provide an insight in the weather conditions (e.g. solar irradiance, temperature, cloud movement – both forecasts and measurements on an hourly or 15-minute basis) and aids in predicting for example reverse power flows due to solar PV.

Since the process starts with data, ensuring a reliable dataset is important. Forecasting algorithms typically need various datasets in order to achieve reliable results. However, the required datasets often have missing values and errors. Therefore, data pre-processing is common practice in the context of load forecasting [137]. Various techniques for data pre-processing can be found in the field of data science. In the context of this research, as a minimum pre-processing level it is required that all gaps in the data are filled (for example with forward filling, or interpolation). Additional to the load forecast, decision-making models might require extra data. Examples are outdoor temperature data to determine the impact of congestion on the transformer and prognosis of market parties' flexibility dispatch on wholesale markets (i.e. participating on the frequency containment reserves balancing market, portfolio optimisation, and day-ahead market trading). Specific input data selection is considered to be part of the development of forecasting and decision-making algorithms, and therefore (in line with section 1.3) out of scope for this thesis.

5.3.2 Step 2. Load forecasting

This section introduces the necessary concepts for the load forecasting algorithm. The load forecast provides insights in the expected net load of each network node, based on the data gathered in the 'data-acquisition' step. This data consists of (among others) the measurements from the distribution networks and local weather forecast data. The exact data requirements depend on the implemented load forecasting algorithm.

In the temporal domain, load forecast differentiates four categories: very-short-, short-, medium-, and long-term forecasts [137]. The required category depends on the application of the load forecasts. (Very-)Short-term load forecasts range from near real-time up to a week ahead, and need a high data resolution. In Dutch distribution networks, a 15-minute data resolution is most commonly available. This is in line with the PTU of the Dutch balancing market. Medium-term forecasts range from weeks-ahead up to year-ahead,

and long-term forecasts look at one or multiple years ahead. Typically, the need for flexibility to prevent congestion is determined one or two days ahead-of-time, depending on the mechanism and implementation. The forecasting window on which this chapter therefore focuses is 24-hour to 48-hour ahead-of-time and, depending on the implementation of the flexibility mechanism, with a 15-minute resolution¹. For continuous markets, a rolling-window forecast can be applied.

The aggregation level of the load furthermore determines the variability in electricity consumption. The law of large numbers intuitively states that on higher aggregation levels the load profile smoothens out. An overview of the performance of load forecasting models for various aggregation levels is presented in [138], demonstrating that the coefficient of variation decreases for increasing levels of aggregation. This chapter focuses on an aggregation level at an MV/LV transformer, which for the Netherlands typically means several tens to hundreds of connected loads. It is shown that for such aggregation level, the variance in the load is small, thus the profile is predictable [138]. For aggregation levels well below a hundred of loads, this variance is significantly higher, causing the profile to be less predictable (i.e. the error in the prediction to increase).

Algorithms

Forecasting algorithms come in numerous forms, ranging from relatively simple regression models (e.g. linear regression, ARIMA, Holt-Winter's exponential smoothing, extreme gradient boosting regression) [139, 140], to machine learning algorithms such as random forest regression [141] or neural network-based models [138, 142, 143].

When choosing a suitable forecasting algorithm, three aspects should be considered: data dependence, computational time, and accuracy. Typically, an algorithm is a trade-off between (input) data dependence, computational time and accuracy. The better the required accuracy, the more complex the model and its inputs get and the higher the computational intensity will be. It is therefore necessary to consider what the minimum accuracy is, and which model is robust enough to offer that with a (for that case) reasonable data dependency and computational time. DSOs furthermore need to take into account that models might need updating, for example when new customers are connected to the distribution network (change in load) or other input data is suddenly outdated.

¹In the EU, 15-minute and 1-hour intervals are two common trading intervals on the balancing and wholesale markets.

Error measurement metric

The performance of a forecasting algorithm is typically measured with an error measurement metric. Various error measurement metrics are described in literature, among which the mean absolute error (MAE), the mean average percentage error (MAPE) and root mean square error (RMSE) are common for comparison purposes, as shown in the overview by [144].

The MAE provides an indicator for the average magnitude of the errors, without taking into account the direction of the error. Individual differences have an equal weight. The MAE is calculated following equation 5.1, where y_j is the actual measured value and \hat{y}_j the predicted value.

$$MAE = \frac{1}{n} \sum_{j=1}^n |y_j - \hat{y}_j| \quad (5.1)$$

The MAPE weighs the error by dividing the difference between forecasted and measured data with the measured data. As a result, each error is again penalised with an equal weight. The MAPE is calculated following equation 5.2, where y_j is the actual measured value and \hat{y}_j the predicted value.

$$MAPE = \frac{1}{n} \sum_{j=1}^n \left| \frac{y_j - \hat{y}_j}{y_j} \right| \quad (5.2)$$

The RMSE on the other hand has a squared proportionality with the size of the error. The RMSE therefore penalises larger differences between forecast and measurement harder than small differences. Since the operationalisation of flexibility has congestion management as use-case, larger differences between forecast and measurement are more critical than smaller differences. Even though the impact of over- and underestimating differs², both effects are considered to be undesirable. Therefore, evaluation based on RMSE has an advantage over the MAPE, in the case of congestion management. The RMSE is calculated following equation 5.3, where y_j is the actual measured value and \hat{y}_j the predicted value.

$$RMSE = \sqrt{\frac{1}{n} \sum_{j=1}^n (y_j - \hat{y}_j)^2} \quad (5.3)$$

²Underestimating loads might result in an overloading, even when flexibility has been procured, whereas overestimating might result in the procurement of too much flexibility, leading to increased costs.

Error visualisation

Since congestion problems are time-dependent, an error visualisation over time is presented. The error visualisation over time provides insights of the performance of the forecasting model during the critical time-window in which a congestion can be expected. The error visualisation can be used together with the overall RMSE value, to evaluate the suitability of a load forecasting algorithm within the context of congestion management. In addition, possible correlations of errors could be analysed as part of future work.

Figure 5.2 is generated as part of the Dutch InterFlex sub-project [145] and shows an example of this error visualisation, showing the error for different times of the day. The time of the day is projected on the x-axis. The left-hand side y-axis shows the time intervals in which is forecasted ahead-of-time (in hours). The colour reflects the RMSE for any time of the day over the entire forecasting window. Additionally, the right y-axis plots the mean transformer load during the day, based on recent measurement data. The mean load is supplemented with the 10-90% and 1-99% datapoint bandwidths, and plotted relative to the rated capacity of the transformer. It can be observed that typically the RMSE values increase for the moments of peak and high variable loads during the day. In this example, in particular the influence of solar PV on the error can be observed in the afternoon hours. This can be explained by the algorithm behind this example being unaware of any weather, causing the forecasted load to be highly variable.

Error minimisation

Furthermore, forecasting models typically are trained to minimise the overall (RMSE) error. Congestion problems however do not typically occur throughout the whole day, but only in specific time windows of the day. As we are interested in peak load forecast, we propose to tweak the objective function such that a higher weight is given to the peak times, or expected congestion windows, of the day and a lower weight is given to the remainder of the day. This is done in two steps:

1. The data-set is split in off- (no congestion) and on-peak (expected congestion) windows;
2. A weight (%) is given to both off- and on-peak windows.

The forecasting model is then trained to minimise the RMSE, according to equation 5.4, where ε is the share of the peak 15-minute intervals in the loss

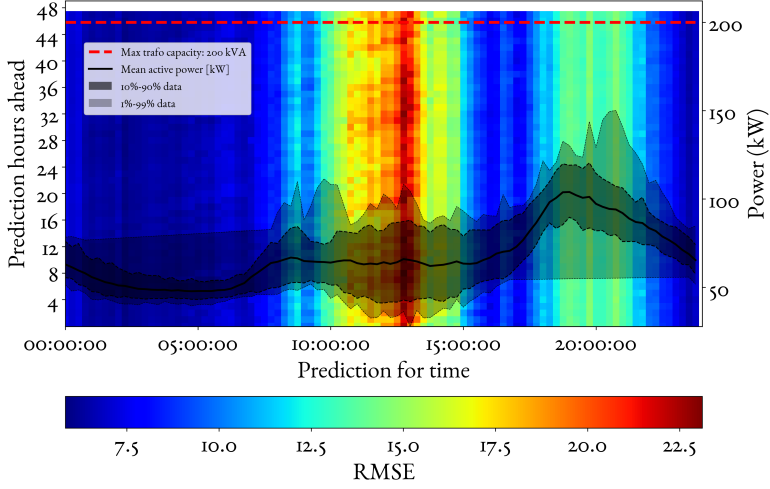

Figure 5.2: Example of the error visualisation.

function, S_{test} is the set of test-data, split into a peak and an off-peak set, \hat{y} the predicted value, and y the actual value.

$$obj = \min \left(\varepsilon \sqrt{\sum_{t \in S_{test}^{peak}} \frac{(\hat{y}_t - y_t)^2}{|S_{test}^{peak}|}} + (1 - \varepsilon) \sqrt{\sum_{t \in S_{test}^{off-peak}} \frac{(\hat{y}_t - y_t)^2}{|S_{test}^{off-peak}|}} \right) \quad (5.4)$$

5.3.3 Step 3. Decision-making

The decision-making model translates the load forecast into the need to operationalise flexibility through a flexibility mechanism in place. In case a small and/or short overloading is expected, the decision-making model might decide to let the overloading occur, depending on the constraints in place. These constraints differ per flexibility mechanism, however generally translate into a cost of flexibility (e.g. market price, contracted price, frequency at which flexibility can be requested). The objective of the decision-making model is to make the trade-off as to when flexibility is needed and what the value of flexibility is (the value is the maximum price DSOs are willing to pay). This is then translated into a flexibility request through the flexibility mechanism.

The value of flexibility for the DSO can be determined by looking at the

alternative costs: the cost of letting an overloading occur. This can be derived from the costs of the lifetime reduction and the risk an overloading results in a power outage. Haque introduces a model to relate the cost of lifetime reduction of a transformer, as a result of an overloading [146]. The financial consequences of a power outage can be found in risk management documents of DSOs. Such documents can be used to compute the direct costs per outage minute a DSO needs to compensate to its customers.

5.3.4 Step 4. Flexibility mechanism interfacing

The flexibility mechanism interfacing is a case-specific interface needed by the DSO to communicate its flexibility needs with the external stakeholders providing the flexibility. This interface varies for the different mechanisms (e.g. tariffs, market). We identify four elements in the interface:

1. System design choices;
2. Generic implicit/explicit flexibility choices;
3. Implementation-specific choices;
4. Protocols and communication.

System design choices

The first element on which a flexibility mechanism interface depends relates to the system design choices. Part of the system design choices is defining the roles and responsibilities in the system. This defines whether the DSO is communicating directly with flexibility providers (e.g. households, in case of implicit flexibility through tariffs), or with an aggregator. The latter limits the amount of systems the DSO needs to interface with, and avoids communication with individual consumers. Additionally, the sources of flexibility need to be identified, for example industrial processes, household appliances, or electric vehicles. This can for instance be done by enriching the DSO's data with publicly available data, as is also applied in network planning, shown by [83].

Another system design choice to be made is regarding the level of interactions. The DSO can choose to facilitate a platform to which every related party connects, or choose for separate connections with various party's platforms.

Generic implicit/explicit flexibility choices

On a generic level, a differentiation can be made between implicit flexibility mechanisms and explicit flexibility mechanisms. Both clusters have their own set of choices.

Implicit flexibility choices: Implicit flexibility choices relate to the implicit mechanism applied (e.g. tariff structures). The first choice to make is the particular implicit mechanism in place. Two alternatives (among others) are tariff based (section 3.2.2, e.g. time-of-use, real-time pricing, critical peak pricing) and a variable contracted connection capacity (section 3.2.4) [52, 89]. In both cases, the key choice to exchange on the interface is the on- and off-peak timeslots (or low and high price timeslots) in relation to the need of flexibility.

Explicit flexibility choices: In case of an explicit flexibility mechanism, flexibility is defined as a product the DSO can obtain from a (flexibility) market (section 3.2.1) when it is needed. The definition of this product flexibility is the first choice that should be made. This depends on the definition of flexibility (see section 2.3) that is used (e.g. whether power or energy is defined as the product's trading unit). Depending on the defined flexibility product and the way it is requested from the market, the interface includes: time of day, location, duration, amount of flexibility, and price of flexibility. Guaranteed availability depends on whether it is contracted beforehand, or whether the DSO sends a request to which a market party can choose to respond. Additionally, it should be considered whether the flexibility market is implemented on a local level, or integrated in the wholesale market.

Implementation-specific choices

Besides generic choices related to the implicit/explicit flexibility mechanism in place, a specific implementation of a mechanism requires some implementation-specific choices. It is not possible to cover all the possibilities, so this section limits to a few examples.

Implicit flexibility choices: Depending on the choice of implicit mechanism, additional levels of prices or loading might be required. This is for example the case for a dynamic tariff, where for every set time-interval (e.g. per hour, per 15-minutes) a price should be set. Another example is in case of a dynamic connection capacity, where the number of on-peak hours per year is fixed beforehand. In such case, the interface should take the amount of used and unused hours of the year, and the remaining time in that year into account.

Explicit flexibility choices: In an explicit flexibility mechanism, various implementation-specific choices can be found. These choices are illustrated using two different implementations of flexibility markets: a local flexibility market, and a wholesale-integrated flexibility market.

In a local flexibility market, the flexibility product is traded in an independent market, parallel to the existing wholesale-level markets. In such local flexibility market, a price is set for the product flexibility (see generic explicit flexibility choices). Besides a price, additional (implementation-specific) choices can be included in the market (e.g. sanction price for non-delivery, available capacity during non-congested timeslots, see section 4.2.2). Additionally, DSOs can request prognoses from the suppliers of flexibility. In these prognoses, flexibility suppliers provide the DSO with an overview of the time-windows in which their flexibility assets are expected to operate, and with which power. An example of the use of prognoses in a local flexibility market is the so-called D-prognosis aggregators provide ahead-of-time as part of the universal smart energy framework [71, 72].

An integrated flexibility market adds a location component to the already existing market. In such setting, the DSO can look for market bids matching with the location in which flexibility is needed, and obtain this flexibility. This can be done either by the DSO taking a market position and activating a specific bid, or by remaining market-neutral and applying redispatch, paying the difference between the two activated bids. An example of an wholesale-integrated market with a DSO-neutral market position is GOPACS (see section 3.2.1 or section 4.3).

Protocols and communication

Last but not least, each interface has a communication module, typically described by a protocol or framework (a high-level description of an interface). This communication module ensures the necessary information is exchanged with the flexibility mechanism, either directly to the source, or through an aggregator, or what else is defined. Examples of such protocols and frameworks are USEF (describing a local flexibility market) [71], EFI (describing four classes in which most flexibility sources fit) [125] and electric vehicle related protocols such as the open smart charging protocol and OCPI protocol by ElaadNL [147].

5.4 Implementation

A proof-of-concept is provided by implementing the four-step approach within the InterFlex sub-project. Additional information on the InterFlex sub-project can be found in section 4.2. Although the four steps are generic, part of the presented implementation is inevitably case-specific.

5.4.1 Step 1. Data acquisition

The step data acquisition handles all necessary data and inputs for the four-step approach. This data is made available for the remaining steps, primarily the load forecast.

Measurement data

For the Dutch sub-project of the InterFlex program measurement equipment is installed on the MV feeders, MV/LV transformers, and LV feeders. Two of the MV/LV transformers act as congestion points. The measurement equipment provides 15-minute averaged values of: voltage, current, active power, reactive power, (bidirectional) energy throughput, and total harmonic distortion.

Network topology

As the load forecast will only forecast the inflexible loads and the flexible loads are forecasted based on aggregator's prognoses, information on the feeders and transformers to which the flexible sources are connected is needed³. Therefore, information regarding the network topology is generally needed to determine whether the flexibility sources can indeed solve a congestion problem, depending on the sources locations and the location of the congestion problem in the network. For adequate forecasting over a longer period, it is needed to take changes in network topology into account, for example by periodically retraining the forecasting algorithm. For the implementation in the InterFlex sub-project, information on the types of connections per feeder and congestion point is available and can be found in figure 4.5. The capacities are provided in section 4.2.

³In the sub-project, flexible and inflexible sources are connected to separate feeders. See section 4.2.2 for the sub-project's network topology.

Prognosis

For each of the congestion points, the aggregators participating in the local flexibility market provide a daily prognosis of the scheduling of the flexibility assets (as discussed in section 4.2.2, this is an obligatory prognosis for participating aggregators). One prognosis is sent per aggregator per congestion point, and contains information on the expected/scheduled load (power) during each of the next day's 96 PTUs. Furthermore, sequence data is added, such that aggregators have the opportunity to update their prognoses while ensuring the DSO always takes the most recent version from the database. To ensure continuity in a pilot setting, the prognosis of seven days before (same weekday) will be used in the case no prognosis has been received in time by the DSO. For real-life implementations, an alternative solution needs to be found for such situations.

Weather data

Weather data is obtained from a contracted party, providing hourly measurements from the nearest weather station and predictions on: irradiation, temperature, probability of precipitation, wind speed, and wind direction. The weather data is obtained through an FTP server, and imported into a database. Both the historical measurements and predictions are saved. In the process, occasionally necessary datapoints are missing. These are filled with data points from earlier forecasts or timeslots. This is automatically done by a parser, developed specifically for the DSO responsible of the demonstrator. The details of this parser can be found in [145], where three DSO-specific implementations/tools are discussed (data pipelines and parsers, load forecasting usable by the DSO, and data clustering algorithms).

5.4.2 Step 2. Load forecasting

The (short-term) load forecasting algorithm is developed by the Dutch Inter-Flex sub-project (section 4.2) and is used to illustrate the operation of the generic four-step approach. The algorithm is explained in high-level by [148], which presents the forecasting model choice, explains which additional features are added to the model, and evaluates the resulting performance gain. The inputs of the forecasting algorithm come from the 'data acquisition' step, described in section 5.4.1. The in-depth analysis and explanations of the design choices are further elaborated upon by Castelijns [145]. This section will provide a concise overview of the implementation of this load forecasting algorithm

and the integration of the load forecasting algorithm in the operationalisation framework.

As market parties are providing the DSO with day-ahead prognoses of the scheduled loads of all flexibility sources, the load forecast only consists of inflexible (dominated by residential) loads. Small-scale PV integration is (implicitly) included in the forecast. To this end, hourly measurements and forecasts of total irradiance, temperature and precipitation are included in the inputs. For the day-ahead market trading, a forecast with 15-minute resolution for the next upcoming 48 hours is provided. By running the forecast every 15 minutes as a rolling-window forecast, the same algorithm can be also used for an intraday market. The training of the algorithm is done with a historical dataset of the demonstration location containing approximately three months of measurements and weather data. Then, the model's performance is verified with two months of test data [148]. This historical set is constrained by the available amount of data at the moment of algorithm development⁴ and does therefore not include all seasonal variations. During the development of the algorithm, an alternative (larger) dataset (including seasonal variations) from another comparable residential area is used to verify the model's performance, including seasonal variations.

The load forecasting algorithm uses timeseries decomposition, to transform the time-series signal into a decomposed signal, consisting of a trend, daily pattern, weekly pattern, and residual signal (the residual of the original time-series signal minus trend, daily-, and weekly pattern) [148]. The Facebook Prophet library [149] is used for this decomposition. After a forecast of the residual signal is made, the decomposed signals are combined to get to the forecasted time-series. Castelijns elaborates further on this procedure [145].

Besides decomposing the signal, a number of time-related (e.g. day of week, weekday / weekend) and weather-related (e.g. irradiance, temperature) features are added to improve the forecasting algorithm⁵. To be able to compare each feature, every feature is scaled to a standardised scale based on the standard normal distribution (equation 5.5), with x'_i as the standardised value, x_i the original value, μ the median (set at 0), and σ the standard deviation (set at 1). Cyclic and dummy features are already intrinsically scaled (Castelijns

⁴This is due to various factors, among which the time needed to install measurement equipment in the distribution network and the quickly developing new loads (a number of apartment buildings were being build and connected to the pilot area at the time of the pilot).

⁵A complete overview of the features added to the forecasting algorithm can be found in [148].

shows how the sine and cosine can be used to model cyclic features [145]).

$$x'_i = \frac{x_i - \mu}{\sigma} \quad (5.5)$$

The load profiles of residential areas in the Netherlands are relatively predictable and peak loads occur around the same time every day [2]. The available data corresponds with this expectation. Therefore, the models are trained based on a weighed RMSE, giving the 15-minute intervals around the time of the peak load (i.e. 19:00 +/- eight 15-minute intervals) a weight of 50%, and the other 15-minute intervals of the day the remaining 5% weight. The model is then tuned to reach the minimal weighted RMSE, following equation 5.4.

After comparing three different machine learning models (linear regression, extreme gradient boosting (XGBoost) regression, and random forest regression), the XGBoost regression model has been selected based on the best performance in terms of weighted RMSE score (7.75 kW).

The XGBoost regression model is evaluated in four variations:

1. Excluding weather input and without decomposition;
2. Including weather input and without decomposition;
3. Excluding weather input and with decomposition;
4. Including weather input and with decomposition.

Figure 5.3 is generated as part of the Dutch InterFlex sub-project [145] and visualises the RMSE for the four variations in the error. Variation 4 has the best overall RMSE performance, where all RMSE values are smaller than 18 kW (compared to an error of approximately 30 kW in variation 1) [145], which improves the RMSE with a difference of over 10 kW during the afternoon hours.

Parallel to the expected transformer load profile, the probability of an overloading occurring is provided. This is done for four boundaries: the probability of exceeding 100% transformer capacity, the probability of exceeding 130% transformer capacity, the probability of exceeding 100% transformer capacity through feed-in (generation), and the probability of exceeding 130% transformer capacity through feed-in (generation). To estimate these probabilities, an error distribution (assumed to be a normal distribution, based on the difference between forecasted values and test dataset) is calculated for each timestep. This is then used to estimate the probability a forecast will exceed the threshold values [145].

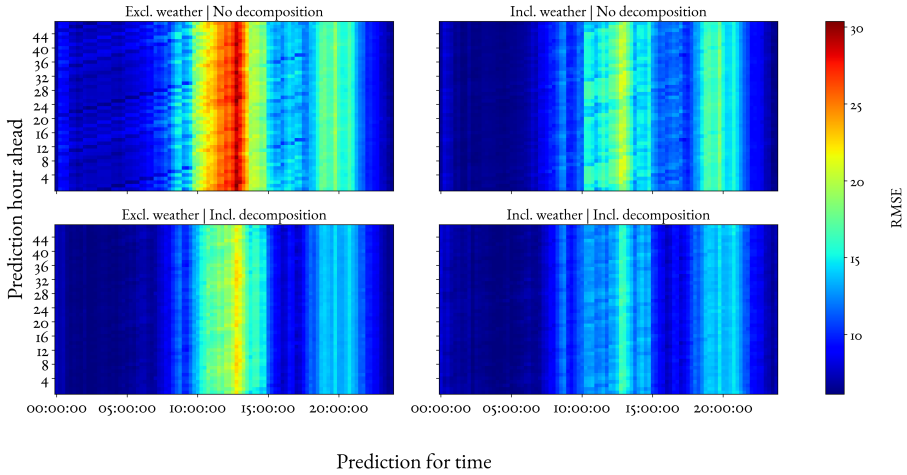

Figure 5.3: XGBoost regression model performance for one of the two congestion points in the Dutch InterFlex demonstrator. For the afternoon hours, the RMSE improves with a difference of over 10 kW, comparing the model including weather features and decomposition with the model excluding weather features and decomposition.

5.4.3 Step 3. Decision-making

The decision-making model is the third step in the operationalisation of flexibility for congestion management. The primary input is the load forecast in combination with the aggregator’s prognoses for the flexibility sources behind a transformer. The decision-making model will, for each location, determine how much flexibility will be requested from the market during each market trading interval (i.e. 15-minute interval), what the maximum price (per kWh) for obtaining flexibility is (the value of flexibility to the DSO), and what the sanction price (per kWh) for non-delivery will be⁶. The initial model is tailored to the day-ahead market, but can be extended to a combined day-ahead and intraday market. First, the amount of expected overloading is determined by comparing the transformer’s forecasted load profile with the transformer’s capacity. For the time-intervals of the expected overloading, the value of flexibility and sanction price of non-delivery is determined.

⁶Non-delivery occurs when an aggregator sells flexibility ahead-of-time, but is unable to deliver it during the moment of congestion. This is discussed in chapter 3 and chapter 4 as the reliability with which flexibility is available. To penalise an aggregator for not delivering, a sanction price is introduced.

Value of flexibility

The value of flexibility is the maximal price a DSO is willing to pay to mitigate congestion. This is determined by two components, namely the cost of component lifetime reduction (i.e. for the MV/LV transformer) and the financial risk of an outage, which - depending on a DSO's policy - could for example include the assumed financial impact of the outage on consumers, regulatory penalties, compensation payments to affected customers and loss of income from tariffs. The sum of the cost of component lifetime reduction and financial risk of an outage is set as the value of flexibility for the DSO.

In order to determine the transformer lifetime reduction, an additional input variable is needed: the outdoor temperature. This is because the transformer lifetime reduction depends on the insulation hot-spot temperature, which in turn is dependent on the outdoor temperature. Insulation hot-spot temperatures up to 140 °C result in a lifetime reduction, while higher temperatures may permanently damage a transformer [2]. In practice, Dutch DSOs typically assume that the insulation hot-spot temperature won't be reached if transformers are temporarily overloaded up to 130% of the rated capacity (max. 2 hours continuously). This assumption is adopted for the decision-making algorithm.

Most distribution network transformers are oil-immersed. The lifetime reduction can be related to the oil temperature, as shown by [150]. A simplified, time-dependent lifetime reduction model, introduced by [146], is adopted in the decision-making model. For the mathematics of the lifetime reduction model, we refer to [146] (section 3.3.1). The following constants are assumed [151]: rated capacity 630 kVA, losses during load 5.1 kW, losses during no-load 0.53 kW, top oil temperature 50 °C, top winding temperature 55 °C.

The simplified lifetime reduction model is used as input for the total lifetime cost (TLC) method described by [146]. The TLC over the lifetime of the transformer is computed, taking into account purchase cost, economic lifetime and energy cost. Equations 5.6, 5.7 and 5.8 describe the TLC model, where C_P is the purchase cost, C_{NL} the no-load loss cost, C_{LL} the load loss cost, C_{TLC} the total lifetime cost, T_t^{lol} the total loss of life at time t (the result of the lifetime reduction model), C_t^{aging} the aging cost at time t , C_{rated}^{aging} the aging cost at rated capacity, and C_t^{ovl} the cost of lifetime reduction at time t . C_{rated}^{aging} is determined using equation 5.7, with the total loss of life for a rated transformer capacity as a load. The following constants are assumed [151]: purchase cost transformer €8000, Economic lifetime 40 year, electricity costs DSO 0.032 €/kWh. Figure 5.4 visualises the costs of an overloading for different levels of transformer loading at different outdoor temperatures, when

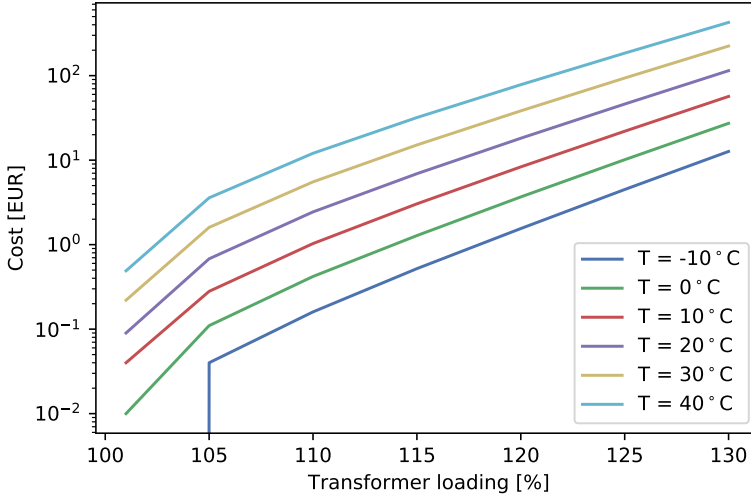

Figure 5.4: Cost of lifetime reduction per percentage overloading for different outdoor temperatures. Figure generated using the lifetime reduction and total lifetime cost model, without considering time-dependence.

not taking into account time-dependence. It can be observed this is not a linear relation.

$$C_{TLC} = C_P + C_{NL} + C_{LL} \quad (5.6)$$

$$C_t^{aging} = T_t^{lol} \cdot C_{TLC} \quad (5.7)$$

$$C_t^{ovl} = \begin{cases} C_t^{aging} - C_{rated}^{aging} & \text{when } C_t^{aging} > C_{rated}^{aging} \\ 0 & \text{otherwise} \end{cases} \quad (5.8)$$

Here, purchase cost, economic lifetime and energy cost are used to compute the cost of an overloading, in case no flexibility is obtained. In the transformer loading regime of 100-130% rated capacity, this cost determines the value of flexibility (thus the maximum price a DSO is willing to pay).

When the load of a transformer exceeds 130% of the rated capacity for more than 30 minutes, the transformer risks getting permanently damaged.

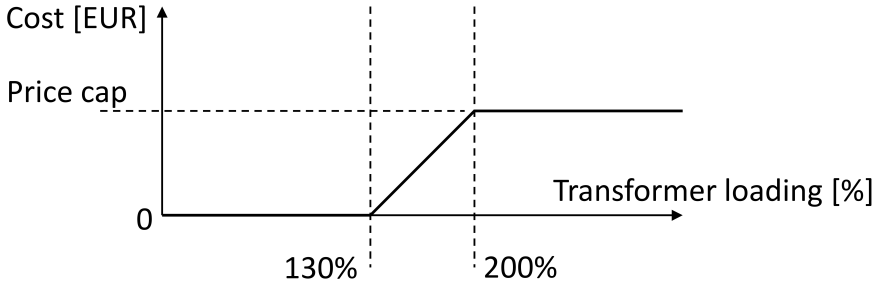

Figure 5.5: Linearized financial risk of overloading.

This results in a risk for a power outage in the distribution network behind the transformer. DSOs have risk-matrices, which can be used to identify the financial risk of a power outage. This financial risk can in turn be used to determine the value of flexibility when preventing an outage from occurring. The potential costs associated with the transformer's permanent damage are not separately taken into account, but assumed to be part of the lifetime reduction and financial risk of an outage.

The financial risk of an outage is related to the customer outage minutes as a result of an outage. According to the DSO in the pilot area, an outage on MV/LV transformer level typically takes 120 minutes to resolve, and a cost of €0.50 per customer outage minute is assumed. This is €7.50 per customer per 15-minute interval. These costs are linearised between 130% and 200% rated transformer capacity (figure 5.5), to ensure a higher overloading has a higher financial risk. The maximum price of €7.50 is set for a transformer loading corresponding with 200% rated capacity.

The total value of flexibility C_t^{flex} at time t can now be determined by equation 5.9, where P_t^l is the transformer loading at time t , P_t^{rated} the rated capacity of the transformer, T_t the outdoor temperature at time t , C_t^{ovl} the cost of lifetime reduction at time t , and C_t^{risk} the financial risk of a power outage at time t .

$$C_t^{flex} = \begin{cases} 0, & \text{if } P_t^l \leq P_t^{rated} \\ C_t^{ovl}(P_t^l, T_t), & \text{if } P_t^{rated} < P_t^l < 1.3 \cdot P_t^{rated} \\ C_t^{ovl}(1.3 \cdot P_t^{rated}, T_t) + C_t^{risk}(P_t^l), & \text{if } P_t^l \geq 1.3 \cdot P_t^{rated} \end{cases} \quad (5.9)$$

Table 5.1: Reflection on the price sensitivity of the customer outage minute assumption per PTU. For each assumed cost per customer outage minute, the effect on the price per MWh per % overloading is calculated.

Assumed cost per customer outage minute	€0.10	€0.25	€0.50	€0.75	€0.90
Cost per % overloading per connection	€0.02	€0.05	€0.11	€0.16	€0.19
Cost at 200% overloading per connection	€1.50	€3.75	€7.50	€11.25	€13.50
€/MWh per % per connection for 630 kVA transformer	€0.79	€1.98	€4.37	€6.34	€7.54

As the financial risk of overloading is based on an assumed value per customer outage minute, a reflection on the sensitivity of this assume value is in order. To this end, customer outage minute values of €0.10, €0.25, €0.50, €0.75, and €0.90 are considered and linearised. An overview of the costs per % overloading per connection, and the maximum costs at 200% overloading per connection can be found in table 5.1. Translating this to the market-prices in €/MWh, for the transformer size used in this demonstrator (630 kVA), this results in a price-sensitivity ranging from 0.79 to 7.54 €/MWh per customer. This results in approximately an order magnitude difference. The result based on the assumed customer outage minute cost of €0.50 is however in the same order magnitude as the worst-case result.

Sanction price

Aggregators have the choice to maximise their profit by optimising their trade on multiple markets. To discourage aggregators from consciously deviating from providing DSOs with the promised amount of flexibility, a sanction price for non delivery is introduced. This sanction price should in theory be higher than an aggregator's potential revenue on other markets. However, for this implementation, the sanction price had to be set day-ahead (as discussed in section 4.2.2). As imbalance prices are not known ahead-of-time, an alternative approach was needed. For the InterFlex sub-project, the sanction price is based on the difference between the prices on the day-ahead market and (downward) balancing market. The forecasted probability of overloading is used to set a risk limit by comparing the forecasted probability with the cumulative probability function of the difference between day-ahead market and (downward) balancing market (manual FRR) prices (figure 5.6). For this, the

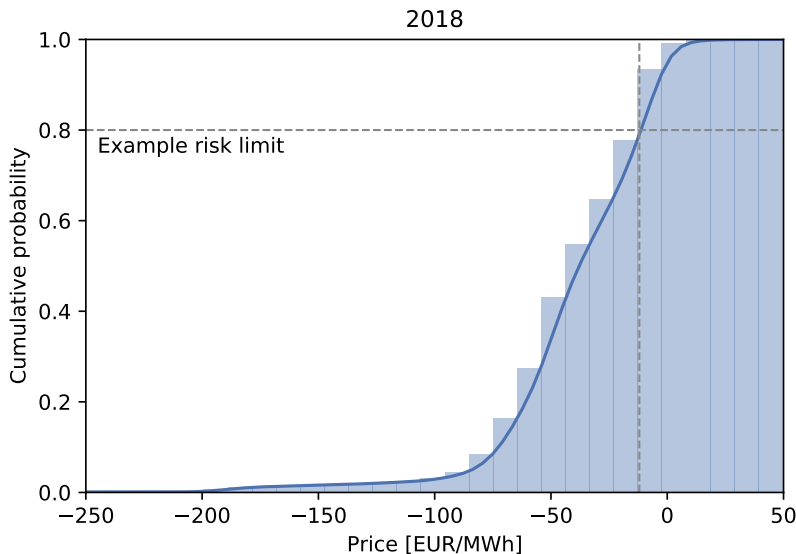

Figure 5.6: Cumulative probability function of difference between day-ahead market and (downward) balancing market prices.

Dutch price distribution of 2018 is used, which can be obtained through the transparency platform of ENTSO-E⁷. Since the implementation of a sanction price is made in the context of a proof-of-concept, no further analysis on the (year-to-year) sensitivity of the balancing and day-ahead market prices has been made.

5.4.4 Step 4. Flexibility mechanism interfacing

The interface and communications/message interactions between DSO and the (explicit) local flexibility market is (on high-level) following the structure proposed by USEF⁸ [71]. This interface can be described in four sub-steps: requesting flexibility, receiving flexibility offers, placing a flexibility order, and (after delivery) settling.

Based on the requests the DSO sends to the market, aggregators return

⁷<https://transparency.entsoe.eu/>

⁸As discussed in section 4.2.2, some adjustments to USEF are made.

flexibility offers. These offers than have to be evaluated by the DSO, and the (most) suitable ones need to be confirmed. After the moment of delivery, the DSO and aggregator settle the delivered flexibility based on the set price and agreed sanction price, based on the methodology described in [123].

5.5 Results & discussion

This section will give an overview of the results of the implementation, with a focus on the ability of the four-step approach to operationalise the DSOs flexibility needs. To maintain the structure of the four-step approach, all four steps are discussed.

5.5.1 Step 1. Data acquisition

Regarding the data acquisition step, the primary concern within the demonstrator is data quality. As mentioned in section 5.4.1, parsers are necessary to fill the occasional gap in the weather forecasting data. Furthermore, the dataset of the measurements in the distribution network needs some processing. Of this dataset, up to 93% of the monthly (active power) data points are received and processed by the database. Of the received measurements, some timestamps are not aligned with the PTU times. Data processing therefore includes two steps: realigning the measurement times with the PTU times, and interpolating missing values.

Some of the data points are missing due to a lack of redundancy in the ICT platform used in the pilot. In a (critical) production environment, the losses could therefore easily be reduced by adding redundancy to the ICT systems.

5.5.2 Step 2. Load forecasting

The forecasting model is trained with a dataset from the InterFlex implementation. There is approximately 5 months' of training data. To account for seasonal variations, the algorithm is further refined using an additional (larger) training set of an alternative (comparable) location. In both cases, two-thirds of the data is used as a test-set, while one-third of the data is used as training-set. The algorithm then is used in the field implementation and operated independently for a few months.

Two weeks (one for each transformer / congestion point) are plotted to check whether the forecast operates as expected. These plots can be found in figure 5.7 and figure 5.8. In general, it can be observed that the pattern of

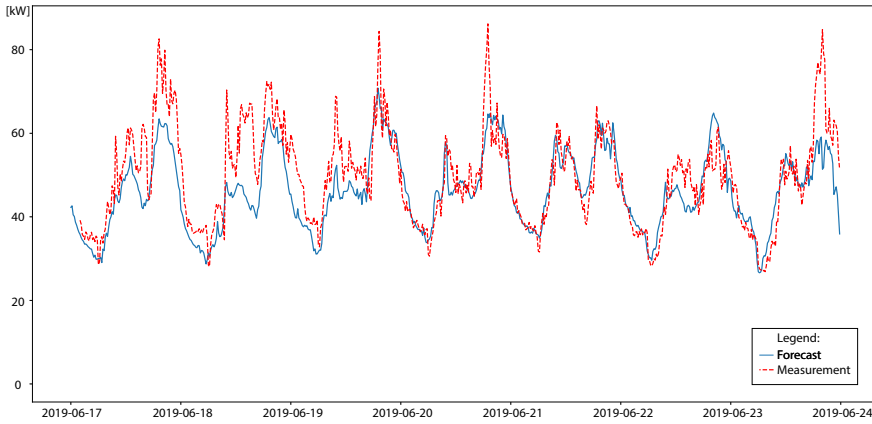

Figure 5.7: Load forecast of a week in June 2019, congestion point 1.

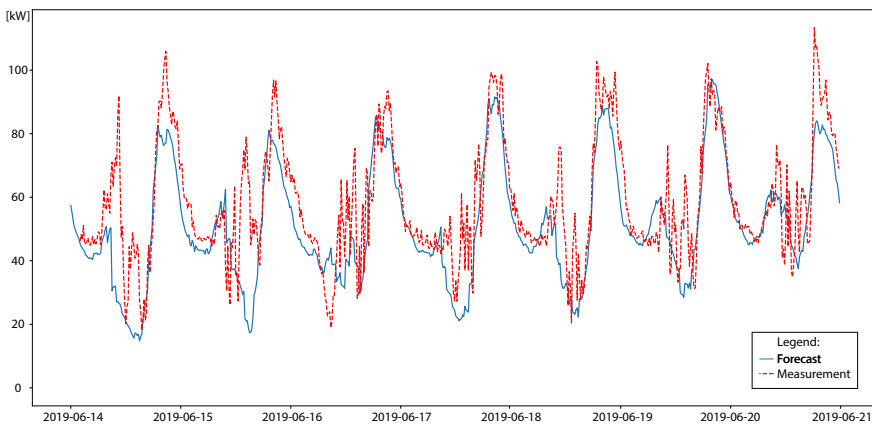

Figure 5.8: Load forecast of a week in June 2019, congestion point 2.

the load forecast and measurements are similar, however the peak load is underestimated. For future implementations an improved forecasting algorithm should be developed and implemented. When developing an improved forecasting algorithm, a methodology to make the error minimisation dependent on a dynamic window, rather than a static moment in time could also be included. This would enable the algorithm to anticipate shifts in the time and

duration of the on-peak hours, which in turn improves the algorithms accuracy.

Furthermore, the algorithm provided has a strong focus on residential loads. The behaviour and accuracy of this model in non-residential environments has not been validated yet. Additionally, this chapter introduces the concept of forecasting error minimisation for the specific use case of congestion management. In the current form, this is done based on a static on- and off-peak timeslot, which works well in situations where the congestion window of the day is known in advance. The results of the case-specific implementation show the forecasting algorithm is able to predict the load's pattern, enabling the decision-making model to determine the flexibility need.

5.5.3 Step 3. Decision-making

The results of the decision-making model are split in two parts. First, the decision-making model is simulated using a month of historical load measurements, to show the value of flexibility in relation to wholesale market prices during congested periods. Then, forecast data from the implementation is used to show the results from the situation in the field.

The simulation results of the behaviour of the decision-making model can be found in figure 5.9 and figure 5.10. Figure 5.9 introduces the load profile of August 2018 for one of the two transformers in the Dutch InterFlex sub-project. As discussed in section 4.2.2, a virtual congestion limit, or assumed transformer capacity, is set. In this plot, the assumed transformer capacity and the 130% assumed transformer capacity are added. This limit is set such that congestion problems can be observed both in the range of the 100-130% assumed transformer capacity and above the 130% assumed transformer capacity. Figure 5.10 then plots the value of flexibility, or the maximum price a DSO is willing to pay for flexibility in those PTUs. Figure 5.9 shows an overloading, at those peaks where the load profile exceeds the assumed transformer capacity. These prices are scaled to €/MWh, and compared to the (competing) wholesale market prices in the same timeslot.

As the measurements are from a warm summer month and the assumed transformer capacity is scaled, the value of flexibility is relatively high. As discussed in [151], this is partly driven by the outdoor temperature dependence of the loss of life of a transformer. This also explains the differences in value of flexibility, for similar percentages of overloading.

From figure 5.10, it can be observed that in those overloading cases of approximating or exceeding the 130% assumed transformer capacity, the value of flexibility is significantly higher than the prices on the wholesale markets. The relation between the cost of a lifetime reduction and an overloading is non-

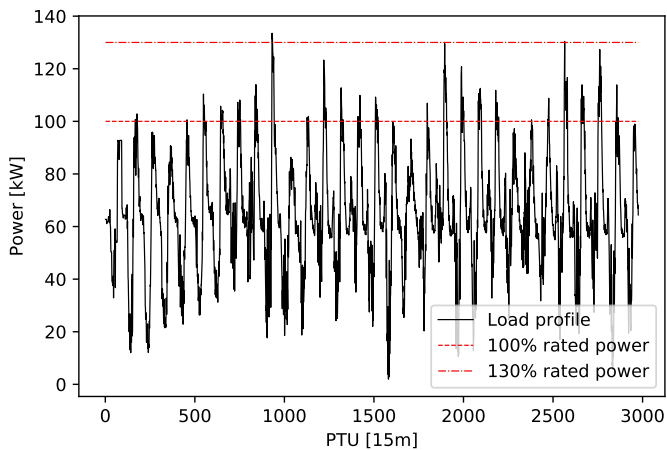

Figure 5.9: Transformer load profile for August 2018 (summer). The assumed transformer capacity (rated power) is set at 100 kW.

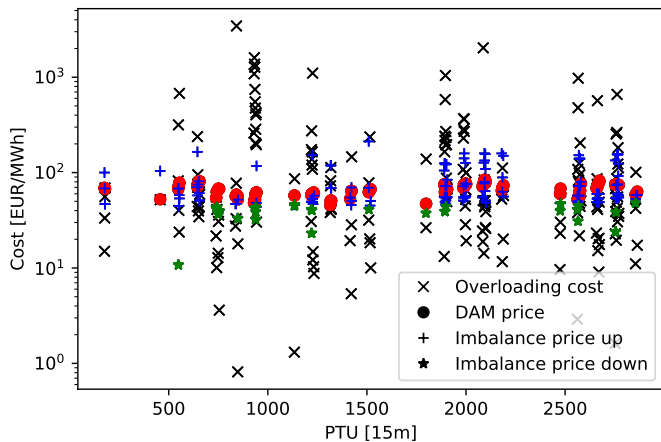

Figure 5.10: Value of flexibility (overloading cost) [€/MWh] for the transformer overloading in August 2018, in relation to the day-ahead market and balancing market prices at the time. For each PTU in which flexibility is requested, the value of flexibility to the DSO, and the prices on the imbalance and day-ahead market are plotted.

linear and the financial risk of overloading adds linear to that for an overloading larger than 130% of the assumed transformer capacity (see section 5.4.3). This implies that (assuming flexibility is available), given the assumed cost functions, the DSO is able to compete with the wholesale market in cases where an overloading approximates or exceeds the 130% assumed transformer capacity. In overloading cases around the assumed transformer capacity, the value of flexibility is on occasion lower than the price on the remaining markets. In those cases, the DSO is unable to compete with the wholesale markets. The DSO can then choose to let an overloading occur, at the cost of transformer lifetime reduction.

Results from the field implementation show the same. Figure 5.11 shows the forecasted load for the last week of June 2019, including prognosis of the flexibility sources. The assumed transformer capacity is 115 kW. The flexibility need is presented in figure 5.12, and the costs of the overloading are computed and visualised in figure 5.13. Here it can be seen that for the relatively large cases of overloading, the value of flexibility to the DSO is higher than the competing market prices. In the cases flexibility is available, the aggregators in the field offered it to resolve the congestion. In case the overloading would be relatively small, the expected value of flexibility is expected to no longer compete with the wholesale market prices.

The assumed transformer capacity is now set at 130 kW, using the same load forecast presented in figure 5.11. Since the transformer capacity now increased, the amount of needed flexibility is less. It can be expected that the price the DSO is willing to pay for flexibility is now smaller, and the price of flexibility in competing markets is expected to be closer to the DSO's value of flexibility. Running this as a simulation, figure 5.14 confirms this.

Currently, the decision-making model evaluates the value of flexibility based on two aspects: the cost of loss of life of a transformer and the DSO's financial risk of a power outage due to overloading. This results in a maximum value of flexibility, depending on the size and duration of the overloading. The needed flexibility is then requested from the market, in which the DSO competes with other market parties. When flexibility is available at an acceptable price, it is procured. All in all, the implementation provides a proof-of-concept for the four operationalisation steps. The current implementation however only facilitates transformers as congestion points. Future work should therefore investigate options for determining loss of life costs on components other than the transformer. This facilitates application towards other congestion points, such as LV feeders, or MV feeders.

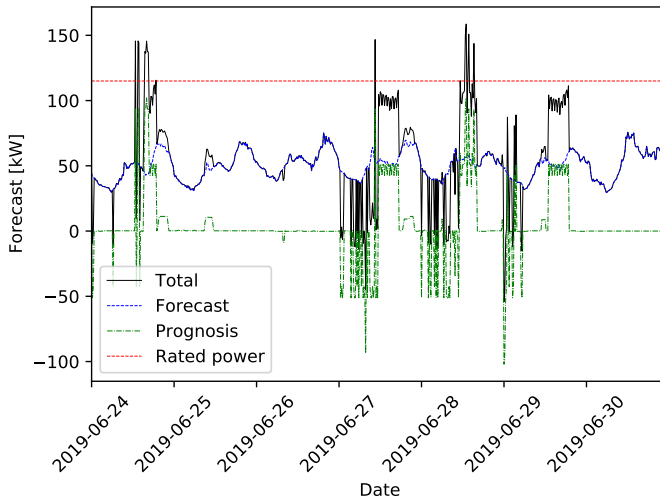

Figure 5.11: Forecasted load profile (forecast of inflexible loads, aggregator prognosis of EV and battery storage, and combination or total of both) for last week of June 2019 (summer). The assumed transformer capacity (rated power) is set at 115 kW.

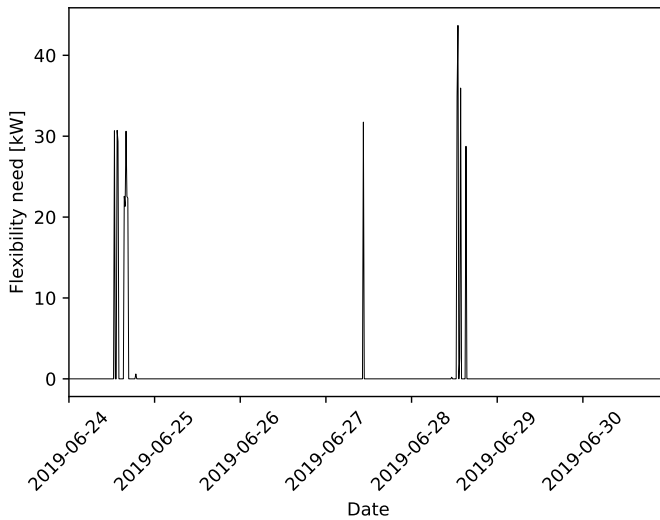

Figure 5.12: Flexibility need for last week of June 2019 (summer).

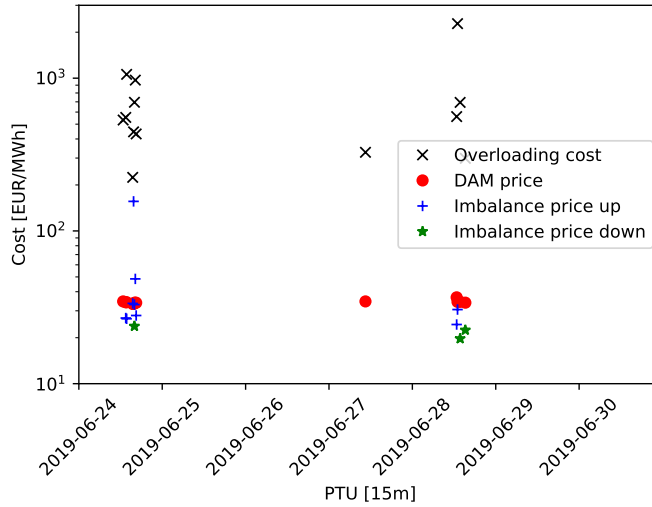

Figure 5.13: Value of flexibility (overloading cost) [€/MWh] for the transformer overloading in June 2019, in relation to the day-ahead market and balancing market prices at the time. The assumed transformer capacity is set at 115 kW.

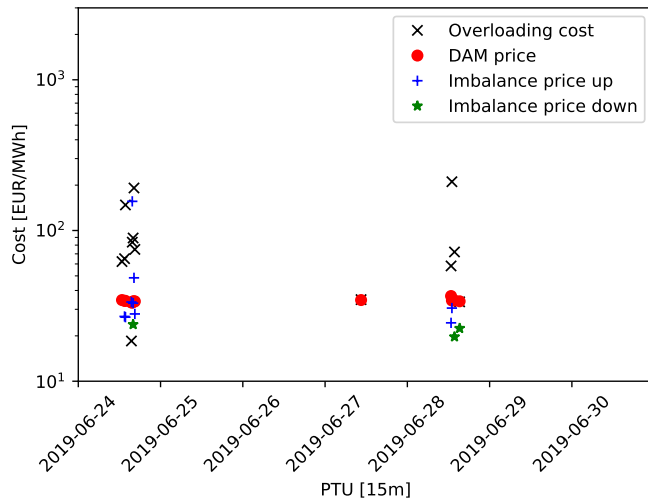

Figure 5.14: Value of flexibility (overloading cost) [€/MWh] for the transformer overloading in June 2019, in relation to the day-ahead market and balancing market prices at the time. The assumed transformer capacity is set at 130 kW.

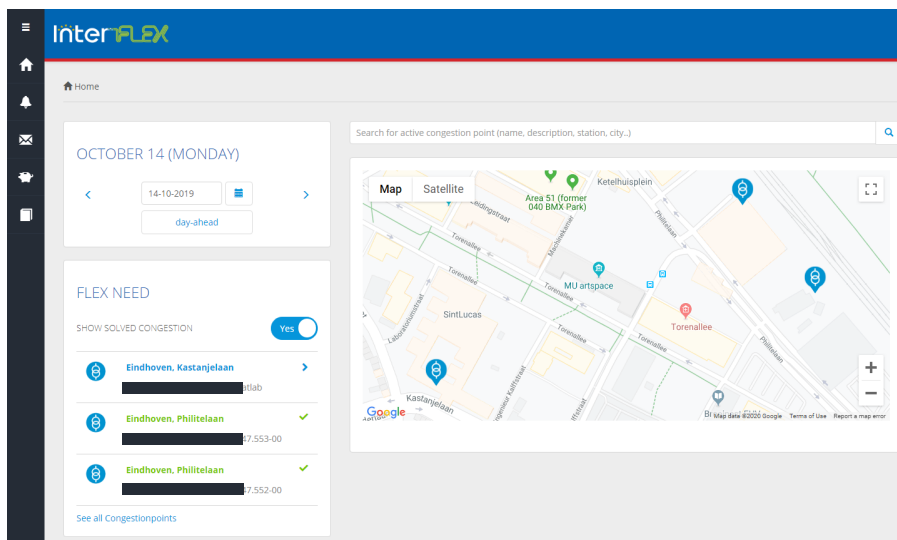

Figure 5.15: Screenshot of the grid management system’s online portal, showing an overview of the congestion points in the region and their respective status.

5.5.4 Step 4. Flexibility mechanism interfacing

The forecasting and decision-making algorithms have been implemented and integrated in the so-called grid management system, with which the local DSO will automatically request the necessary flexibility. To monitor the grid management system, for the InterFlex sub-project a case-specific implementation is developed in an online portal. In this portal, the congestion points can be seen, including their status. A screenshot can be found in figure 5.15, illustrating the specific situation in the field. Naturally such monitoring system or portal can be implemented and visualised differently depending on preferences and case-specific characteristics.

Then, the details of each congestion point can be further analysed. Figure 5.16 shows an example of a specific congestion point in the InterFlex sub-project’s implementation. In this figure it can be seen during how many PTUs congestion occurs, in how many of these PTUs flexibility is ordered, and whether the congestion is solved. Furthermore, the status of the interactions and messages with the market can be found. Further information in this system provides insights in the content of the actual XML messages, and provides additional specification of the exact amounts of overloading of the congested

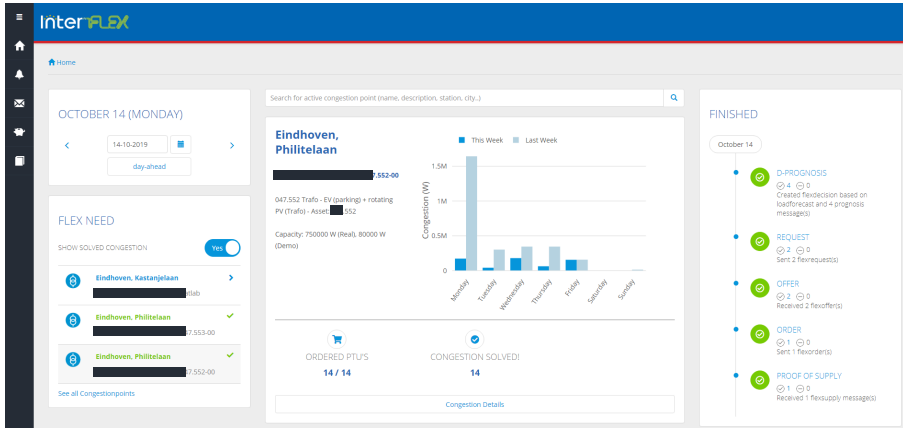

Figure 5.16: Screenshot of the details of a specific congestion point. The amount of PTUs in which congestion occurs and the amount of PTUs in which congestion is solved can be observed. On the right-hand side, the steps (messages) of the interactions with the market can be found.

PTUs. The desired information and its visualisation can of course differ for other implementations.

Analysing the messages between the DSO's market interface and the aggregators in the period between August 1, 2019 and September 30, 2019, we observed a total of 415 requests for flexibility being sent to the aggregators. Of this, 204 requests are on the first congestion point, and 211 requests on the second (multiple congestions per day). Two (commercial and local) aggregators are connected to each congestion point (see section 4.2). On the first congestion point 172 and 91 offers of flexibility have been made respectively by the two aggregators. On the second congestion point, 192 and 89 offers of flexibility have been made respectively. On the first congestion point, the DSO obtained flexibility 134 times, of which 84 orders are sent to aggregator 1, and 50 orders are sent to aggregator 2. For the second congestion point, these amounts are 99 and 52 respectively.

A number of things can be observed based on the message interactions. First of all, the flexibility from EV amounts in 91 and 89 offers, and 50 and 52 orders made, for congestion points one and two respectively. In the context of the demonstrator this can be explained by the unpredictability of EV. Only a limited amount of EV drivers participated in the pilot, and the charge points were in a public area, primarily hosting EVs which parked only temporarily.

This makes it hard to predict when, where, and for how long an EV will be parked.

Secondly, out of the 204 and 211 respective flexibility requests, the DSO only obtained flexibility in 134 and 151 cases. This can be explained in different ways. One explanation is that market prices are higher than the cost of a transformer's lifetime reduction (thus the value of flexibility). In such cases, the DSO chooses to accept a lifetime reduction. Another explanation is flexibility being unavailable, thus aggregators not being able to respond to the DSO's request for flexibility. Furthermore, aggregators might intend to shift their load to another timeslot, causing a new congestion elsewhere in the day. In the pilot this is communicated as part of the message exchange between DSO and aggregator (see section 4.2.2). This allows the DSO to make a decision whether to accept the bid or to let the initial congestion occur.

In the context of this pilot, the lack of available flexibility does not lead to any issues in the network, as the virtual congestion limit or assumed transformer capacity is well below the network's physical limits. However, when implementing a market like the one in this demonstrator in real-life, DSOs should ensure sufficient flexibility is available, especially to avoid exceeding the limit of the 130% assumed transformer capacity. This can for example be done by implementing a non-market-based fall-back, based on direct control, as discussed in section 3.3.

5.6 Conclusions

The research question answered in this chapter is: *What tools do DSOs need to make decisions on the every-day deployment of flexibility for network-support, and how can DSOs apply these tools?* A four-step method introduced in this chapter provides the DSO with the tools needed to make every day decisions on the employment of flexibility for network-support. The chapter furthermore elaborates on how the four-step approach can be applied. The four steps and their relations are defined in a generic and scalable manner, enabling alternative algorithms and models for all individual steps. An algorithm is provided for forecasting and decision-making. The decision-making model evaluates the (maximum monetary) value of flexibility based on two aspects: the loss of life of a transformer and the DSO's financial risk of a power outage due to an overloading.

A case-specific implementation is presented as an illustration, providing a proof-of-concept for the four operationalisation steps. The results of this implementation show the forecasting algorithm is able to predict the load's

pattern, enabling the decision-making model to put a monetary value on the required flexibility. This value is, depending on the size of the overloading, competing with the flexibility markets, and enables the DSO to obtain the needed flexibility when available. All in all, the implementation provides a proof-of-concept for the four operationalisation steps. Several hundreds of flexibility requests have been sent to the market over a period of a few months. The market has however not been able to answer all of those. For this, three reasons can be identified: no flexibility was available at the time, other markets offered more money, or the market price of flexibility was larger than the value of flexibility for the DSO. Next steps in extending this operationalisation approach would include an analysis of possible alternative forecasting and decision-making models, and mapping the accuracy, computational intensity, complexity, and input data dependence of these alternatives. This not only provides DSOs with the basics steps to get to an operational decision, but also enables them to do this with a tailored model for their own needs in any specific use case.

6 | Baseline flexibility

6.1 Introduction

One of the main barriers in the deployment and evaluation of (demand-side) flexibility is baselining. The DSO and flexibility providers need to settle on delivered flexibility. When flexibility is provided, the behaviour of the flexibility source can be captured by load measurements. It is, however, not possible to also measure the behaviour of a flexibility source in case no flexibility would have been provided. The expected behaviour is therefore captured in a so-called baseline.

According to [152], accurate baselines are needed in order to enable flexibility utilisation. To achieve this, the availability of measurements and historical baselines is required. A more in-depth discussion of baselining can be found in [153]. A baseline forms a synthetic and hypothesised profile, and therefore per definition has an error. This observation is seen as a threat to consumer's participation to a flexibility program, as the (financial) compensation of flexibility provided depends on the accuracy of the baseline. It is furthermore argued that although baselining is already applied for (large) industrial and commercial loads, providing an accurate baseline for smaller devices with irregular consumption might be a challenge [153]. The work of [154] takes the transmission system perspective of deploying flexibility, analysing operational planning, operations, and settlement. As part of his analysis, [154] identifies the lack of an appropriate baselining methodology as the most urgent barrier for aggregators to provide balancing services.

This chapter is based on:

R. Fonteijn, P.H. Nguyen, J. Morren, J.G. Slootweg. Baselining Flexibility from PV on the DSO-Aggregator Interface, *Applied Sciences*, 11(5), 2021.

Numerous authors have pointed out the necessity of truth-telling in flexibility schemes. Chen et al. analysed a flexibility program from a game theoretical perspective [155]. The flexibility program is tested for its truth-telling and cheat-proof behaviour. The authors show the need for truth-telling in a distributed solution, with consumers behaving naturally selfish. The universal smart energy framework (USEF) foundation identifies gaming as one of the issues with their (self-reported) baseline model, in which deviations from the reported baseline are not penalised [71, 156]. In [157], a DR program is implemented, taking the system operator's perspective. Consumers report their baseline and to ensure truth-telling, consumers deviating from the baseline - while not providing promised flexibility - are penalised with a random penalty. An alternative implementation of this flexibility program uses a reported baseline in which consumers not only provide their baseline, but also their marginal utility [158]. The authors showed that by adding the consumer's marginal utility, prices for penalty and reward for flexibility delivery vary over time.

In the USA, baselining has been applied for over a decade already. In 2008, a study aiming at standardising baseline methodologies has been conducted. In this study, various models are compared based on a statistical analysis of their performance [159]. The five different methodologies defined by the USA's energy standardisation board are presented in [152, 160]. Both conclude that multiple methodologies are required, as no one-size-fits-all solution is available. Every case is individually analysed, and the most suitable baselining methodology is selected. An alternative approach is presented by [161, 162]. Here, a regression-based baseline model has been developed, also focusing on the USA perspective in relation to large industrial and commercial loads.

More recently, [163, 164] focus on residential loads, and [164] focuses on the European context. In [163], it is found that improving the baseline accuracy and reducing the bias does not necessarily result in improved economic benefits of a model. The authors assess the total stakeholders' profits for five different (measurement and calculation based) baseline models. It is found that baseline models with a bias positive to the customers result in higher customer participation. An alternative to measurement and calculation based methods, is a control group based method. Hatton [164] proposes a statistical method of control group selection, which eliminates the need for historical datasets. The approach is tested on residential loads with flexibility from air-conditioners and electric heaters, appliances with a high coincidence factor.

Most baselining research focuses on the American power system. With the ongoing energy transition and increasing use of flexibility, the European perspective is however increasingly studied [71, 156, 164, 165]. In [165], baseline

models are compared for the Baltic states. The statistical model as applied in France (see also [164]) is considered not to be viable, because of the immature flexibility market in the Baltic states. Regression-based models are dropped based on the USA market's rejection in 2009 [165]. The common practice in the EU is considered to be the *window-before* approach, in which meter readings taken before flexibility activation are used to set a baseline. An alternative is the *window before and after* approach, however this is considered to be more vulnerable to manipulation, by affecting the consumption after the window to influence the baseline [165]. The accuracy of this methodology is further limited when the flexibility source has an irregular load profile and shows variations that do not follow normal daily/weekly cycles. This is a problem earlier identified by [153].

Until recently, baselining research focused on large-scale, predictable loads. As a result of the energy transition, it is urgent to increasingly utilise flexibility to avoid network congestion and overloading. This flexibility often consists of less predictable, small-scale loads such as EVs, HPs, battery energy storage and PV. Traditional baselining methodologies are not always suitable for these types of loads. Moreover, these baselining methodologies typically focus on a market-customer interface, whereas flexibility to avoid congestion and overloading of distribution grids needs to be settled between an aggregator party and a DSO.

This chapter answers the following sub-question: *How can DSOs settle the delivered flexibility with the market, ex-post, and what are suitable solutions to use in daily operation?* To this end, this chapter analyses the baselining challenge between the DSO and an aggregator for a day-ahead flexibility market, in the context of utilising flexibility in distribution networks. Three existing baselining methods are selected based on their simplicity and transparency. The methods' applicability towards PV systems is evaluated, providing insight in their limitations. A fourth (hybrid) method, maintaining simplicity and transparency, is proposed. This novel method overcomes some of the limitations of the first three methods, as shown in a proof of concept.

6.2 Baselines in literature

Literature on baselines typically describes the baselining problem from two perspectives: 1) the type of baseline and its implementation, and 2) the criteria relevant for the evaluation in a particular application. In this section we start discussing the latter.

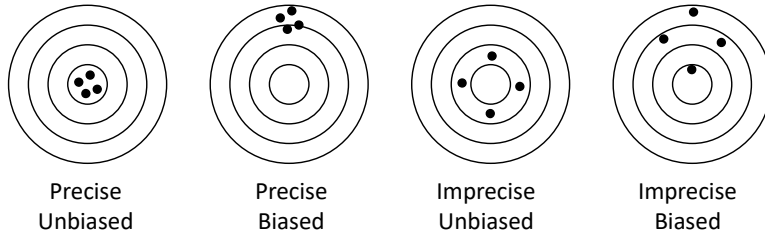

Figure 6.1: Precision and bias in relation to the criterion accuracy.

6.2.1 Evaluation criteria

In order to evaluate the performance of a baselining methodology, evaluation criteria are required. The accuracy of the baseline is a key evaluation criterion and typically the only quantifiable criterion considered. However, it is not the only relevant criterion. Several other (qualitative) criteria should be considered as well, such as transparency, integrity, simplicity, inclusiveness, and proneness to manipulation.

Accuracy

Accuracy can be considered from two perspectives, i.e. precision and bias. The *precision* describes how close determined values are to each other, providing a measure for the statistical variability. Literature often focuses on precision, when talking about accuracy in general (e.g. [165, 163]). A baseline methodology is considered to have a *bias* when there is a systematic over- or underestimation, of a consistent magnitude. Bias is also known as trueness and is sometimes considered as a separate parameter, for example in [163]. Having a biased baseline is not necessarily a problem. In the work of [163], a positive bias (overestimating the baseline, benefiting the customer) has led to a higher customer participation. Although this bias increased the costs of DSOs, it also ensured that sufficient flexibility was available to DSOs. This (according to [163]) in turn led to higher overall profit. Figure 6.1 further illustrates the difference between precision and bias, in the context of the concept of accuracy. A baseline is considered accurate, when it is both precise and unbiased.

Simplicity

Simplicity, or its opposite *complexity*, is a criterion describing how easy or hard it is to implement and understand a baselining methodology. This criterion is addressed extensively in literature (e.g. by [152, 165, 166, 167]). In particular [168, 169] consider this to be a crucial criterion. According to [168, 169], a baselining methodology has to be easy to implement in order for DSOs and market parties to adopt it.

Transparency

In order for a baselining methodology to be adopted by the DSO and market parties, it is not only necessary to be simple. *Transparency* is equally important [168]. Transparency is necessary to facilitate the required degree of trust that market parties have in the fair outcome of the settlement process. Transparency ensures market parties know exactly how the baseline is produced and which data is used. This allows them to reproduce a baseline in order to validate it and ensures settlement is fair. As data is an important part of baselining, the process of measuring and providing the required data also has to be transparent, in particular when (parts of the) data is measured or provided by a single stakeholder.

Inclusiveness

Inclusiveness is the extent to which the behaviour of different types of flexibility assets can be described by a single baselining methodology. It is debatable whether a high degree of inclusiveness is possible while still meeting the other criteria. This is also a reason no one-size-fits-all baselining approach has been proposed so far.

Proneness to manipulation

Proneness to manipulation, also known as *integrity*, describes the extent with which a baselining methodology is prone to manipulation. Two examples of manipulation are described by [167]. The first example is called *user dilemma*, which refers to flexibility providers (users) influencing the future baseline by actively delivering flexibility. The future baseline often (only) takes into account recent historical load measurements. These measurements also reflect flexibility delivered in the past, thus affecting future baselines. Secondly, [167] discusses gaming, or baseline cheating, which refers to the baseline being influenced by intentionally increasing consumption (or production) in the days

before flexibility is delivered. Gaming possibilities are also identified as a factor by [152, 166]. Besides user dilemma and gaming, uncertainty in behaviour (e.g. temperature dependency) might result in deviations of baselines. This is however not considered to be part of proneness to manipulation.

Other considerations

Apart from the evaluation criteria discussed in this section, it is important to realise that any baselining methodology should facilitate flexibility to be used in multiple markets. As discussed by [168], owners of flexibility assets should be able to optimise the benefits from the flexibility they provide. This means a DSO cannot expect an asset owner will keep flexibility exclusively available for the DSO. Measurements at the location of flexibility assets are often used by the DSO to determine a baseline. These measurements might include - or be 'contaminated' by - flexibility offered to other markets, e.g. the balancing market.

Evaluation criteria are sometimes known under different terms in literature. Examples are the opposing criteria simplicity and complexity, and integrity and proneness to manipulation. These criteria are also categorised differently in the literature. In [165], for example, the criterion *robustness* is presented. Robustness links the criteria *integrity* and *bias*, discussed above.

Regardless of the choice or categorisation of the evaluation criteria, a trade-off is typically required. It is not possible to score well on each individual criterion. Building a baseline that is simple and transparent, inherently leads to a trade-off in terms of e.g. accuracy and inclusiveness, and so forth. The design choices and the argumentation for a specific baselining methodology (and the choice of consistent evaluation criteria) are therefore more important, than the categorisation of the evaluation criteria that are chosen.

6.2.2 Baseline methodologies

The various baselines found in the literature can be clustered in eight categories¹:

1. Window before;
2. Window before and after;

¹Alternative categorisations are possible. For example, [168] identifies six categories: averaging, regression, machine learning & hybrids, control groups, schedules, and interpolation.

3. Prognosis;
4. Historical;
5. Calculated;
6. Machine learning;
7. Control group;
8. Combinations/other.

The remainder of this section examines these eight categories in more detail. A description of each methodology is provided and the advantages and disadvantages are discussed, using the evaluation criteria described above. Additionally, an overview of specific implementations and/or analysis of each of the methodologies in literature can be found in appendix C.

Window before

The *window before* methodology takes a measurement (e.g. a single measurement, an average/minimum/maximum value over a time window) from before the moment of activation of the flexibility. This methodology's advantage is its simplicity. *Window before* is easy to implement and transparent to all users and market parties. It is however potentially prone to manipulation. In order to minimise the risk of anticipation or gaming, the single measurement used for baselining preferably is a measurement from a timeslot at which the aggregator was not yet notified of the demand for flexibility.

The accuracy of the window before methodology largely depends on the variability of the flexibility source. For relatively stable (i.e. limited short-term variations) flexibility sources the accuracy might be sufficient. However, for highly variable flexibility sources the accuracy of a single measurement before activation may be insufficient. This baselining methodology is commonly used and can be found in for example references [159, 160, 163, 165, 167].

Window before and after

The *window before and after* methodology is similar to the *window before* methodology. However, in this case both a (set of) measurement(s) from before and after the activation window is used. This can for example be based on single measurements, or an average/minimum/maximum value over a time window. Like the window before methodology, the window before and after

methodology is easy to implement and scores well in terms of transparency. The methodology is however also prone to manipulation. For the measurement before activation, the same argument as in the window before methodology can be made. However, as market parties know a measurement from after the activation window will also be used to determine the baseline, this value could be influenced by the market parties for their benefit.

The overall accuracy of the baseline again depends on the variability of the flexibility source. It is better than the accuracy of window before, as interpolation methods can be applied based on the two values that are known. However, for variable sources this may not be sufficient. This baselining methodology can be found in the overview presented by [165].

Prognosis

The *prognosis* or *nomination* methodology uses an ex-ante prognosis, describing the expected behaviour of the flexibility sources. This method is for example applied in the universal smart energy framework (USEF) [71, 156], where the aggregator provides the DSO with a prognosis. Another example is the settlement process of system imbalances. Balance responsible parties (BRPs) provide the transmission system operator with a prognosis, based on which the system imbalance will be settled ex-post [170].

This baselining methodology is transparent for market parties and easy to understand. Information and communication technology (ICT) is required to enable market parties to provide their prognoses to the DSO. The required protocols and interfaces are not yet standardised, complicating practical implementation. The accuracy depends on the ability of market parties to estimate their future behaviour accurately, for which the law of large numbers applies. While on transmission level BRPs are able to provide relatively accurate prognoses, at low-voltage level individual flexibility sources are highly unpredictable. This is in particular the case for EVs [42].

The proneness to manipulation depends largely on the way a prognosis baseline is implemented and whether or not a penalty for deviations is taken into account, as shown with two examples. On the one hand, USEF does not penalise aggregators for a deviation of their baseline, leaving it prone to manipulation [71, 156]. On the other hand, transmission system operators settle the imbalance costs with BRPs based on the provided baselines, providing BRPs an incentive not to cause system problems by deviating from their program [1, 20].

Historical

The *historical* (rolling) baseline methodology uses historical measurements over a longer period. This method is extensively described in literature. Implementations can be based on the average value of the measurements of x out of y days [159], or using an exponential moving average [163].

For this baselining methodology, proneness to manipulation not only refers to gaming, but also to the discussed *user dilemma*: the baseline is determined using historical values, so - unless a method is agreed upon to eliminate periods in which flexibility has been delivered from the dataset - by providing flexibility today, the future baseline of the flexibility source is influenced (typically at the expense of the user's business case). Gaming is harder with the historical baseline, as this implies aggregators would need to structurally adjust their behaviour on days no flexibility is activated.

This baselining methodology is easy to understand, but slightly more complicated to implement. ICT infrastructure is necessary to determine the baselines. This ICT infrastructure needs to be interfaced with (amongst others) measurements and the measurement data should be correct and available at all times. In terms of transparency it is paramount that market parties have an agreement on the measurement data used, as this is necessary for reproducible and verifiable results. For traditional sources (e.g. large, predictable industrial loads) this method scores well in terms of accuracy. The accuracy however quickly drops when flexibility assets are volatile and have different profiles every day. This baselining methodology is commonly referred to in the literature, and can be found in for example references [159, 163, 164, 165, 167].

Calculated

The *calculated* baseline methodology introduces a baseline based on a mathematical description rather than measurements and data. This mathematical description may still use data, but aims to eliminate the necessity of accurate and reliable measurements at the point of connection of flexibility assets. The calculated methodology is discussed by [164] and implemented by [160].

A subcategory of the calculated baseline methodology is the *regression-based* methodology. Here, a regression model is used to calculate the baseline. An example is the spline fixed effect change point model, proposed in [171]. The regression-based baselining methodology is broadly referred to and applied in literature, and can be found in e.g. [159, 161, 162, 163, 164].

In general, the calculated baselines perform worse than the previously discussed methodologies in terms of simplicity and transparency. It is less clear

how the baseline is determined, which depends on mathematical algorithms rather than measurements. The upside of the use of algorithms can however be found in the proneness to manipulation. As models determine the outcome of the baseline, aggregators do not have an opportunity for gaming and the user dilemma is eliminated. The accuracy of calculated baselines largely depends on the accuracy of the models of the flexibility sources considered.

Machine learning

Machine learning implementations are nowadays also used as a baselining methodology [172, 173, 174, 175]. By using a 'black-box' approach, machine learning eliminates the baseline's proneness to manipulation. Furthermore, it can potentially better describe the behaviour of the more fluctuating flexibility assets, resulting in a higher accuracy. However, there are also disadvantages, namely a lack of transparency and simplicity, which are essential for market parties to accept a baselining algorithm. This even applies when the algorithm would be published, due to the intrinsic complexity of machine learning approaches.

Control group

With the *control group* or *peer group* methodology, the baseline is determined by taking the measurements from a control group similar to a flexibility source cluster. The control group is supposed to represent the behaviour of the flexibility source cluster. When no flexibility is activated in the control group, it can be used to establish the baseline for the flexibility source cluster.

Hatton et al. applied the control group methodology in France and identified two key advantages of the control group approach, namely [164]:

1. No large dataset with historic measurements is required. This method can therefore be applied immediately.
2. Manipulation effects of flexibility sources are avoided.

However, Hatton et al. also identified a disadvantage of control group baselining, as participating in a control group would imply not providing any flexibility, making this less attractive [164]. This disadvantage could (partially) be mitigated by defining a control group dynamically, which could work if the group is large enough to ensure that at any given moment in time, sufficient participants do not wish to provide flexibility.

The control group methodology is insensitive to gaming and the user dilemma, since the flexibility on the one hand, and the data to determine the baseline on the other hand, are obtained from different groups of customers. This, however, results in an approach less simple to understand and implement, so that this is a less transparent baselining methodology. In practice, choosing the control group transparently in such a way that it accurately represents the behaviour of the flexibility cluster in case no flexibility would be provided, is challenging. One reason for this is that it is often unknown to a DSO what exact appliances are behind a connection. Furthermore, some customers might have such unique load profiles that none of the control group customers is a close match.

Combinations / other

It is possible to combine multiple methodologies. This is for example done by Xia et al., applying a combination of a regression-based and conventional baselining methodology [167].

An alternative to applying a baseline is the so-called *drop-to* approach, in which settlement is done based on a preset power level to which an aggregator needs to drop, regardless of the behaviour that would otherwise have occurred. This is for example applied by Rossetto [160]. This facilitates financial compensation, as to this end only the measurements have to be compared with the preset *drop-to* level instead of to a baseline. An advantage of drop-to is the simplicity and transparency. The disadvantage is the fact that when the baseline would already be close to the drop-to value anyway, the DSO is paying relatively much for the acquired flexibility, whereas when the baseline would deviate significantly from the drop-to value, the financial compensation for the aggregator might be low, discouraging participation.

6.3 Methodology

This chapter analyses the baselining challenge on the DSO and aggregator interface (more on this interface in section 6.3.2). This is done explicitly for PV, as PV is currently causing most capacity problems, making solutions for congestion caused by PV most relevant to DSOs. To this end, four baselining methodologies are evaluated: three existing methods and one novel method. Alternative flexibility assets (e.g. EV, HP and battery energy storage) are discussed qualitatively. The behaviour of the PV-only system is modelled with a standard Python implementation (section 6.3.4) and is used to generate the necessary dataset to analyse the baselines (section 6.3.5).

6.3.1 Selected baseline methods

An overview of various evaluation criteria used for baselines is presented and discussed in section 6.2.1. This chapter focuses on providing the DSO with the tools needed to settle flexibility. Therefore, the chosen solution should be simple to understand and implement for the DSO, and transparent for market parties. That is why, as mentioned in section 6.2.1, the criteria transparency and simplicity are considered to be boundary conditions for any baselining methodology to be adopted. In the context of this chapter, machine learning methodologies and control group methodologies are therefore excluded, as they do not meet the transparency and simplicity criteria (see also section 6.2.2).

As simplicity and transparency are paramount for the acceptance by the DSO and market parties, the following three types of baselining methodologies are implemented for evaluation and benchmarking:

- Window before;
- Window before and after;
- Historical.

Additionally, a novel approach is proposed, also meeting the precondition of simplicity and transparency. More on the implementation of the methods in section 6.3.5.

6.3.2 DSO - aggregator interface

The DSO-aggregator interface is a case-specific interface used by DSOs to communicate their flexibility needs with aggregators. This interface varies for different approaches towards utilising flexibility (e.g. day-ahead flexibility markets, capacity or curtailment agreements).

The chosen approach towards enabling DSOs to utilise flexibility and the corresponding interface affect the baselining solution. It is therefore necessary to explain the assumptions behind the interface, as these assumptions lay at the basis of the measured load profile (including its flexibility):

- Day-ahead flexibility market;
- Gate-closure at 12:00 (noon);
- DSO requests flexibility of aggregator, aggregator complies.

Table 6.1: Summary statistics of the solar irradiance, outdoor temperature and wind speed. The following labels are used: M for measurement data and F for the day-ahead forecast.

	Irradiance [W/m ²]		Temperature [°C]		Wind [m/s]	
	<i>M</i>	<i>F</i>	<i>M</i>	<i>F</i>	<i>M</i>	<i>F</i>
<i>1-8 Jun</i>						
minimum	0	0	10.2	10.8	0.0	1.0
maximum	889	864	31.3	31.7	10.0	9.0
average	233	258	18.4	19.4	3.4	3.5
<i>1-8 Jul</i>	<i>M</i>	<i>F</i>	<i>M</i>	<i>F</i>	<i>M</i>	<i>F</i>
minimum	0	0	9.2	8.7	0.0	1.0
maximum	881	885	25.3	24.9	7.0	6.0
average	272	287	17.4	17.3	3.4	3.3
<i>1-8 Aug</i>	<i>M</i>	<i>F</i>	<i>M</i>	<i>F</i>	<i>M</i>	<i>F</i>
minimum	0	0	11.6	13.1	0.0	1.0
maximum	817	758	26.3	25.4	8.0	6.0
average	206	226	19.4	19.2	3.2	3.4

6.3.3 Input data

Weather data from the year 2019 for the city of Eindhoven, the Netherlands is used as input for the simulations. This dataset contains hourly weather measurements and forecasts (up to 36 hours ahead) of solar irradiance, outdoor temperature, and wind speed of a single location (a weather station). Some statistics of the input data can be found in table 6.1. From the table it can be observed that during the selected period in August, both the maximum and average irradiance are a bit lower than during the selected periods in June and July.

6.3.4 PV model

The PV system is modelled using Python's *pvl*ib library². From this library, the following functions are used sequentially, in order to model the behaviour of a generic PV system (including the relevant parameters and their values):

- *pvl*ib.temperature.pvsyst_cell(), to determine the cell temperature using the weather parameters solar irradiance, outdoor temperature and wind speed.

²

Table 6.2: PV system parameters.

Parameter	Value
Peak power	1000 W
Azimuth	180 °
Tilt	0 °
Other parameters	default

- *pplib.pvsystem.PVsystem()*, to model the PV system, with the basic model parameters $pdco = 1000$ and $gamma_pdc = -0.004$, where $pdco$ is the module's direct current (DC) power rating at cell reference temperature and $1000W/m^2$ irradiance. $gamma_pdc$ is the temperature coefficient in units of $1/^\circ C$ [176].
- *pplib.pvsystem.pvwatts_dc()*, using the solar irradiance and PV cell temperature profile to generate a DC profile.
- *pplib.pvsystem.pvwatts_ac()*, using the DC output profile and the parameter $pdco = 1000$ to generate an alternating current (AC) profile.

Table 6.2 presents some key parameters of the implemented system. Other parameters are set to their default values. Additional information on the PV models of the *pplib* library can be found in [176].

Using the weather data, two output profiles with a peak power of 1 kW are generated: the forecasted PV output (ex-ante) and the PV output based on the measurements (ex-post).

6.3.5 Implementation

In order to evaluate the different baselining methodologies, a number of steps need to be taken. These steps follow the flowchart presented in figure 6.2. The steps are briefly described below, after which a more elaborate description is provided on the implementation of the curtailment process and of the different baselining methodologies.

- Step 1: The expected day-ahead PV output is determined, using weather forecasts and the PV model described in section 6.3.4.
- Step 2: The PV output profile is compared to a pre-set congestion threshold to determine the required flexibility (curtailment), and its duration.

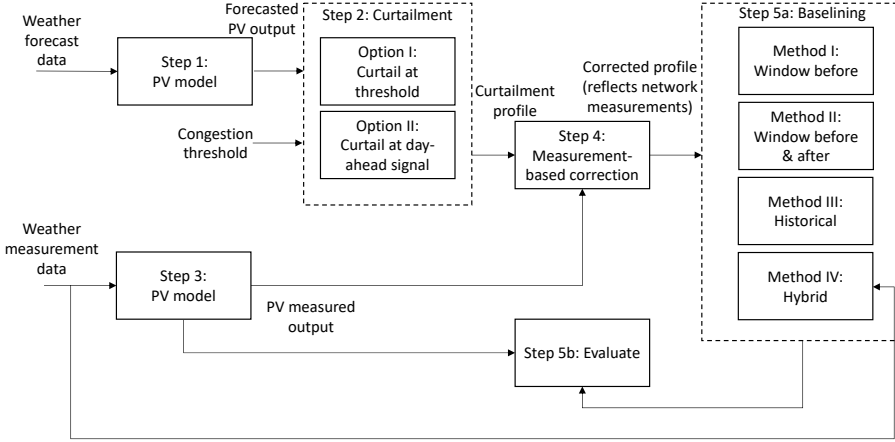

Figure 6.2: Overview of the implementation flow of the different baselining methodologies.

- Step 3: The actual PV output profile is generated, using weather measurements and the PV model described in section 6.3.4.
- Step 4: The actual PV output profile is cross-referenced with the expected curtailment profile, correcting the curtailment profile for the actual behaviour on the day of flexibility delivery. The output of this *ex-post measurement-based correction* consists of synthesised measurement profiles of the flexibility asset. In a real-life implementation this step can be skipped.
- Step 5: The various baselines are determined (a) and evaluated (b), using the root mean square error (RMSE, equation 6.1) and mean absolute error (MAE, equation 6.2) as error metrics, where y_j is the reference profile and \hat{y}_j the baseline profile.

$$RMSE = \sqrt{\frac{1}{n} \sum_{j=1}^n (y_j - \hat{y}_j)^2} \quad (6.1)$$

$$MAE = \frac{1}{n} \sum_{j=1}^n |y_j - \hat{y}_j| \quad (6.2)$$

Curtailment

The (expected) curtailment profile is determined day-ahead and three variations are implemented: option 1, option 2a, and option 2b. Option 1 assumes the DSO will notify a market party that curtailment is needed during every timestep in which a predetermined congestion threshold would be (partially) exceeded. This could for example be used to facilitate larger amounts of PV in a congested region by curtailing the PV during the limited periods of time it runs at peak production. Option 1 is also known as scheduled reprofiling [177]. For option 2 (both a and b) it is assumed that the DSO will provide a selected curtailment window. This is for example applicable if, during some periods of time, sufficient load is present, thus curtailment of the PV installation is not necessary for a whole afternoon, but for a window of a few timesteps only, implying the DSO does not need to obtain flexibility for every peak. Option 2 is also known as conditional reprofiling [177]. Option 2 is split in 2a and 2b. For option 2a no flexibility has been activated in the previous week and for option 2b flexibility has been activated in the previous week. This differentiation is of importance for baselining methods using historical data, as this historical data includes the previously activated flexibility, thus yielding a method vulnerable to the *user dilemma*, described in section 6.2.1.

Ex-post measurement based correction

The objective of this step is synthesising a measurement profile of the PV system. In a real-life implementation, this step would therefore not be required. As the curtailment profile is determined day-ahead, based on the expected PV output, a correction needs to be made to determine the actual profile as it would be measured in a real-life situation. To this end, an ex-post measurement based correction is made by comparing the PV output based on the weather measurements with the curtailment profile. When the PV production is lower than the curtailment profile, the curtailment profile is corrected downwards. When the PV production exceeds the expectation, this surplus is added to the curtailment profile. This new, corrected profile represents load measurements that would have been acquired at the flexibility asset in a real-life situation.

Baseline method I: window before

The window before baselining methodology is implemented by using the last measurement before flexibility activation as a baseline for the flexibility activation period. Equation 6.3 describes the baselining procedure mathematically,

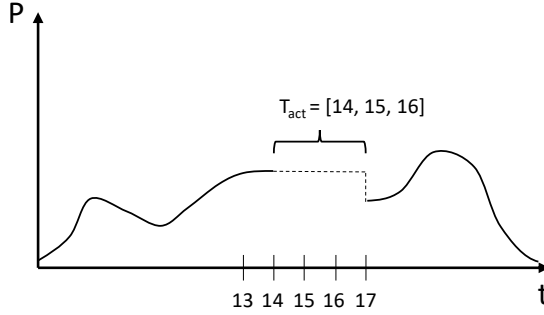

Figure 6.3: Illustration of baseline I and its activation period. The dashed line reflects the baseline.

in which t is the timestep, T_{act} is the list of activated timesteps, and P_t^{meas} the power measurement at timestep t .

This method is illustrated in figure 6.3 and the following example: Assume a curtailment request starting at 14:00 and lasting three hours. In this example, the $T_{act} = [14, 15, 16]$, and during this period the baseline is set equal to the previous timestep (in this example, timestep 13).

$$P_t^{base} = \begin{cases} P_{t-1}^{meas} & \text{if } t \in T_{act} \\ P_t^{meas} & \text{otherwise} \end{cases} \quad (6.3)$$

Baseline method II: window before and after

The window before and after baseline uses the last measurement before and the first measurement after the flexibility activation. During the flexibility activation, linear interpolation is used to generate a baseline for the intermediate timesteps. Equations 6.4 and 6.5 describe the baselining procedure mathematically, in which t is the timestep, T_{act} is the list of activated timesteps, $|T_{act}|$ the length of the activation period, t_{act} the first activated timestep, P_t^{meas} the power measurement at timestep t , and $P_{t_{act}-1}^{meas}$ the power measurement at timestep $t_{act} - 1$.

The method is illustrated with the same example as in section 6.3.5. Figure 6.4 visualises the baseline applied for method II, illustrating the newly introduced variable t_{act} (the first activated timestep, in this example 14). In this example, the baseline values for the timesteps in T_{act} are derived from a linear interpolation between the last step before (timestep $t_{act} - 1 = 13$) and first step after activation (timestep $t_{act} + |T_{act}| = 17$).

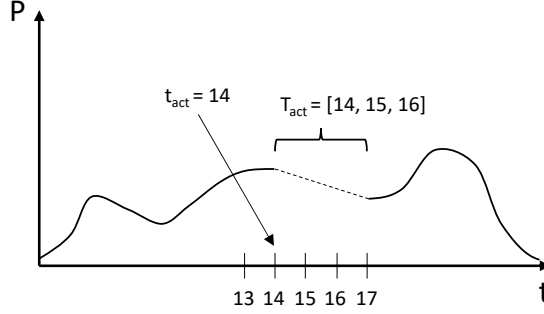

Figure 6.4: Illustration of baseline II and its variables. The dashed line reflects the baseline.

$$\frac{\Delta P^{base}}{\Delta t} = \frac{P_{t_{act}+|T_{act}|}^{meas} - P_{t_{act}-1}^{meas}}{|T_{act}| + 1} \quad (6.4)$$

$$P_t^{base} = \begin{cases} \frac{\Delta P^{base}}{\Delta t} (t - (t_{act} - 1)) + P_{t_{act}-1}^{meas} & \text{if } t \in T_{act} \\ P_t^{meas} & \text{otherwise} \end{cases} \quad (6.5)$$

Baseline method III: historical

The highest x out of y (historical) baseline is implemented using the highest 3 out of 5 historical days. As the flexibility source is PV, no differentiation is made between week days and weekend days. For each individual timestep, the same timestep is taken from the last five days, after which the three highest values obtained are averaged and used as the baseline value for the respective timestep.

Equations 6.6 and 6.7 describe the baselining procedure, where x and y represent the highest x (i.e. 3) out of y (i.e. 5), T_{act} represents the list of activated timesteps, and \bar{P}_t represents the average power at timestep t . Figure 6.5 illustrates this method, in which the highest 3 out of 5 historical days are used.

$$\bar{P}_t = \frac{1}{x} \sum_{k=0}^x \max_k (P_{i,m}) \quad \forall i, 1, \dots, y \quad \forall m \in T_{act} \quad (6.6)$$

$$P_t^{base} = \begin{cases} \bar{P}_t & \text{if } t \in T_{act} \\ P_t^{meas} & \text{otherwise} \end{cases} \quad (6.7)$$

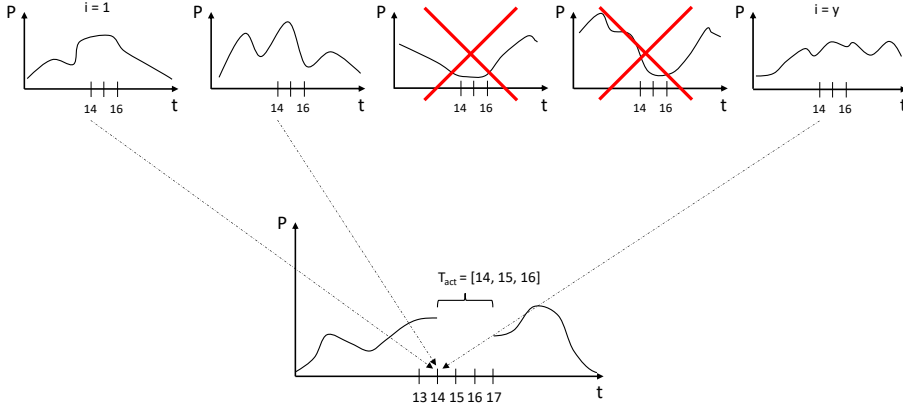

Figure 6.5: Illustration of baseline III and its variables. The necessary data is taken per timestep, for the previous y days. As only x out of y historical days are included, not all historical values are needed.

Baseline method IV: combined historical & calculated

The fourth proposed method is novel. This method is a hybrid form and combines a highest x out of y (historical) baseline with a calculated correction based on the solar irradiance at the time. The highest x out of y baseline is implemented similar to *baseline method III*, taking the highest 3 out of 5 historical days. In addition, for each timestep, the historical measurements of the irradiance are captured, both for the historical days and the day of curtailment. The average irradiance, corresponding with the highest 3 out of 5 measurements is then used to scale the baseline with the measurement at the timestep of activation.

Equations 6.8 and 6.9 describe the baselining procedure, where x and y represent the highest x (i.e. 3) out of y (i.e. 5), T_{act} represents the list of activated timesteps, T_{max} is the list of timesteps (day, hour) of the highest x out of y days, I_t the irradiance at timestep t , \bar{I}_t the average irradiance at timestep t , and the average power \bar{P}_t is determined using equation 6.6. Figure 6.6 illustrates this method.

$$\bar{I}_t = \frac{1}{x} \sum_{k=0}^x I_{k,jl} \quad (j, l) \in T_{max} \tag{6.8}$$

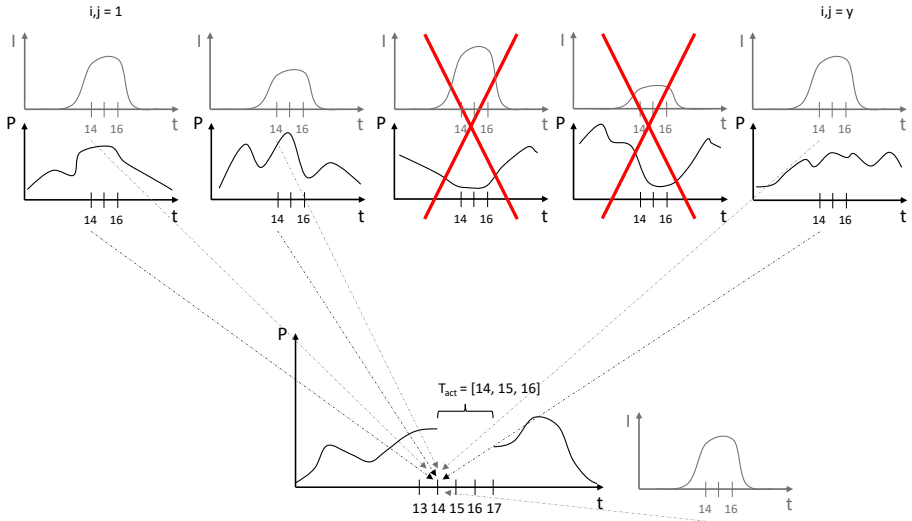

Figure 6.6: Illustration of baseline IV and its variables. The necessary data for \bar{P}_t is taken per timestep, for the previous y days. The necessary data for \bar{I}_t is taken for the exact same days used for \bar{P}_t . As only x out of y historical days are included, not all historical values are needed.

$$P_t^{base} = \begin{cases} \frac{I_t \bar{P}_t}{I_t^{meas}} & \text{if } t \in T_{act} \\ P_t^{meas} & \text{otherwise} \end{cases} \quad (6.9)$$

6.4 Results

This section presents the obtained results. First, the weather data is presented, as this has a strong influence on the further outcomes. Then, the reference profiles for the PV generation are presented. These are the profiles with which the baselines are benchmarked. This is followed by the curtailment profiles, both before and after correction. Finally, the behaviour of the baselining methods and a discussion of the results are presented.

6.4.1 Weather profiles

To evaluate the four baseline methods, three summer weeks with different weather profiles are selected³: the first week of June, July, and August. This data is used as the input for *steps 1 and 3* of section 6.3.5. Figures 6.7, 6.8, and 6.9 provide a visualisation of the irradiance data. It can be observed that, in terms of irradiance, the actual values differ quite a bit from the forecast. This is most likely caused by cloud movements, which are challenging to forecast accurately in a day-ahead setting. It furthermore is clear that the daily fluctuations in irradiance can be significant. This is in particular the case for the first weeks of June and August. It can be expected that this affects the results, in particular for method III, which takes historical data into account. As flexibility is expected to be needed primarily in the weeks with the highest PV production, the visualisations of the results in this section are based on the first week of July.

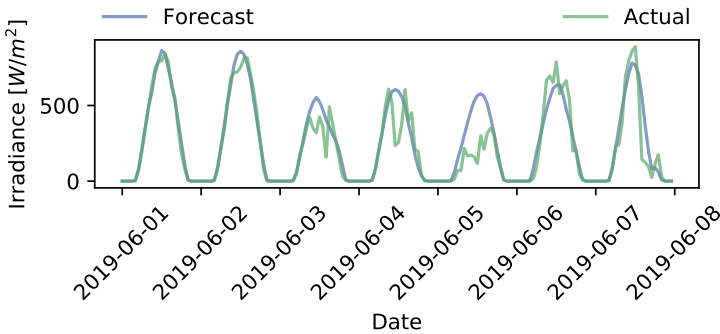

Figure 6.7: Comparison of forecasted and measured irradiance data during the first week of June 2019.

6.4.2 Reference profile

The reference profile is the PV output profile generated during *step 3*, using irradiance measurements (section 6.3.5). The reference profile reflects the unconstrained PV output, given the weather conditions. This profile is used

³This research limits itself to summer weeks, as in the Netherlands curtailment of PV is not expected to occur in the winter-periods. As the generation of curtailment profiles is done manually (see section 6.4.3), the number of analysed weeks is limited.

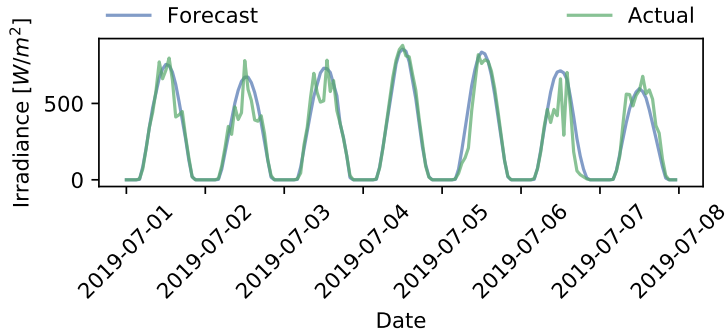

Figure 6.8: Comparison of forecasted and measured irradiance data during the first week of July 2019.

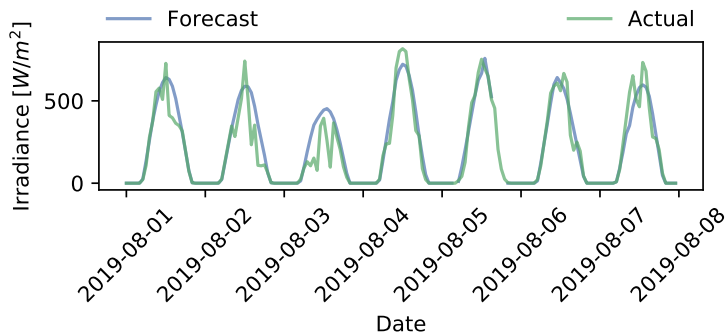

Figure 6.9: Comparison of forecasted and measured irradiance data during the first week of August 2019.

to benchmark the performance of the selected baselining methods. The four baselining methods' error metrics are computed using the reference profile. Figure 6.10 shows an example of the profile, during the first week of July 2019.

Besides benchmarking the performance of the four baselining methods, the reference profile is also used to correct the (expected, day-ahead) curtailment profiles (*step 4*).

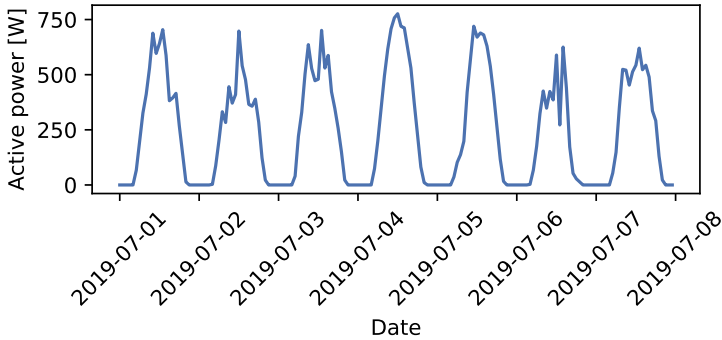

Figure 6.10: Example of the reference profile with which the baselining methods are benchmarked.

6.4.3 Curtailment profiles

This research distinguishes between different curtailment variations: option 1, option 2a and option 2b (see section 6.3.5). The day-ahead flexibility requests set a fixed curtailment level at 578 W. This value represents 75% of the maximum forecasted PV power. In case of curtailment option 1, all expected PV production larger than this limit is curtailed.

Curtailment option 2 (a and b) represents the DSO explicitly requesting flexibility at specific timeslots. In the context of this research, this is done by manually setting curtailment limits at these timeslots. The limit is again 578 W. For option 2 (a and b) the timeslots at which curtailment is requested are the following:

- June 2 from 11:00 until 15:00;
- June 7 from 10:00 until 14:00;
- July 4 from 12:00 until 15:00;
- July 5 from 12:00 until 16:00;
- August 5 from 12:00 until 14:00.

In case of curtailment option 2a, no flexibility has been utilised in the last week of May, June and July. The historical data used with methods III and IV is therefore not influenced by flexibility activation. The user dilemma

(section 6.2.1), part of the criterion *proneness to manipulation*, does therefore not play a significant role.

In case of option 2b, flexibility has been utilised in some of the days in the last weeks of May, June and July. This is expected to reflect back in the results of methods III and IV, as the historical data used to get the baselines is now influenced by previously activated flexibility. The additional timeslots at which flexibility is activated for curtailment option 2b are the following:

- May 27 from 12:00 until 14:00;
- May 29 from 12:00 until 16:00;
- May 31 from 12:00 until 14:00;
- June 29 from 12:00 until 16:00;
- June 30 from 12:00 until 16:00;
- July 1 from 12:00 until 16:00;
- July 30 from 12:00 until 14:00.

Figures 6.11 and 6.12 show the curtailment profiles for curtailment options 1 and 2 (a & b). These profiles correspond with the results of steps 2 (before correction) and 4 (after correction), described in section 6.3.5. It can be observed that in some cases the curtailment limit is exceeded because irradiance was higher than predicted day-ahead. Depending on how conservative a DSO sets its flexibility needs in advance, higher than expected irradiance might cause overloading as this was not foreseen when determining the (day-ahead) curtailment limit. On the other hand, it can also be observed that in some cases the day-ahead predictions overestimate the reality. This can lead to a curtailment profile, where the DSO requests market parties to provide flexibility, which, however, turns out to be no longer necessary, as in reality solar irradiance is lower than predicted.

6.4.4 Baselining methods

In *step 5*, described in section 6.3.5, the baselining methods are evaluated. This is done for the curtailment options 1, 2a and 2b, and for the three first weeks of June, July and August 2019. Figures 6.13, 6.14 and 6.15 present an overview of the results for each of the four baselining methods for the different curtailment options during the first week of July 2019. This week represents a typical high PV production, during which a DSO might be expecting congestion problems.

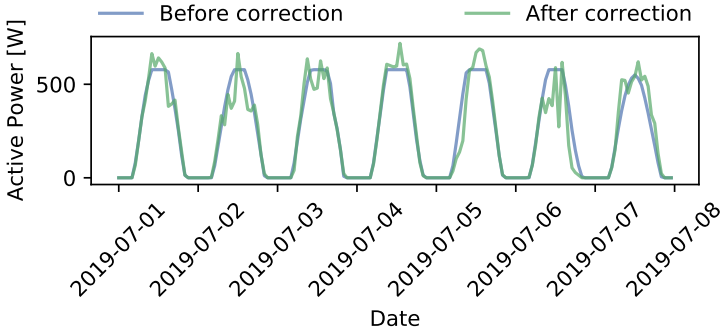

Figure 6.11: Curtailment profiles, before and after correction, for curtailment option 1.

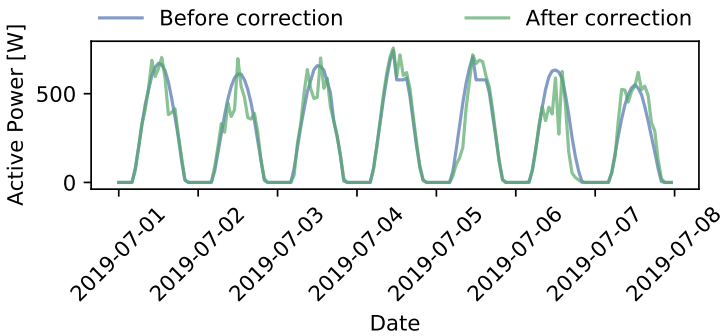

Figure 6.12: Curtailment profiles, before and after correction, for curtailment option 2.

Method I

Method I is the most simple way of implementing a baseline. The last measured value before flexibility activation is used as the baseline for the duration of the flexibility activation. In particular with curtailment option 1 (figure 6.13), this causes significant levels of inaccuracy: when curtailing the entire peak production, method I per definition underestimates the baseline. Therefore, this baselining method is less suitable for situations in which peak PV produc-

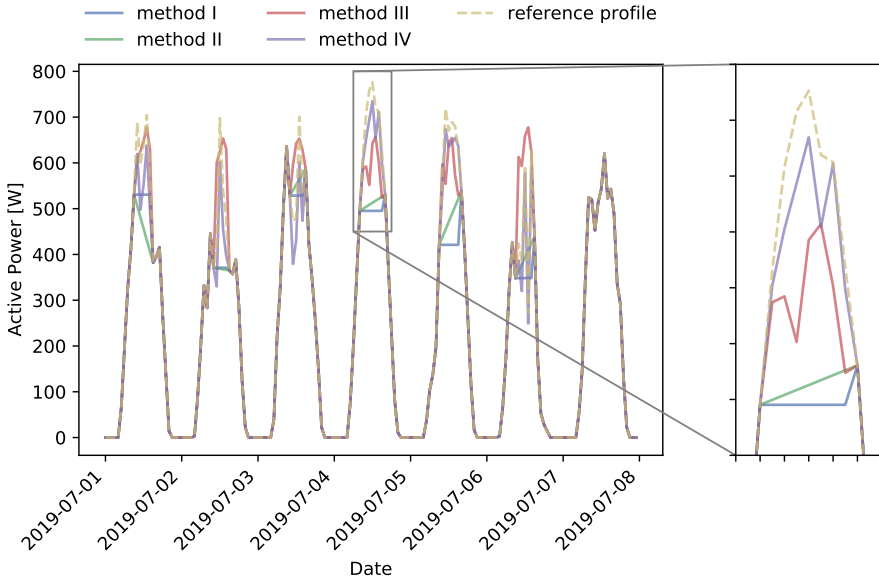

Figure 6.13: Comparing different baselining methods for curtailment option 1.

tion is continuously curtailed. In case the DSO requests flexibility from the market (curtailment option 2), this baseline’s accuracy will largely depend on the moment the DSO starts with flexibility activation, and its duration. It can be observed in figures 6.14 and 6.15 that when curtailment occurs on the peak of the day (e.g. July 4), the baseline is an overestimate of the reference profile. Vice-versa, when curtailment starts before the peak, like in curtailment option 1 the baseline is expected to be underestimated. For flexibility activation over multiple timesteps, method I is also inaccurate. Due to the method’s simplicity, it might however perform satisfactorily for flexibility activation during a single (short) timestep, as the error will be limited.

Method II

Method II is based on a linearisation, using the last measured value before flexibility activation and the first measured value after flexibility activation. Like method I, method II is inaccurate when curtailing the entire afternoon PV peak. This can be observed clearly in figure 6.13. For such curtailment

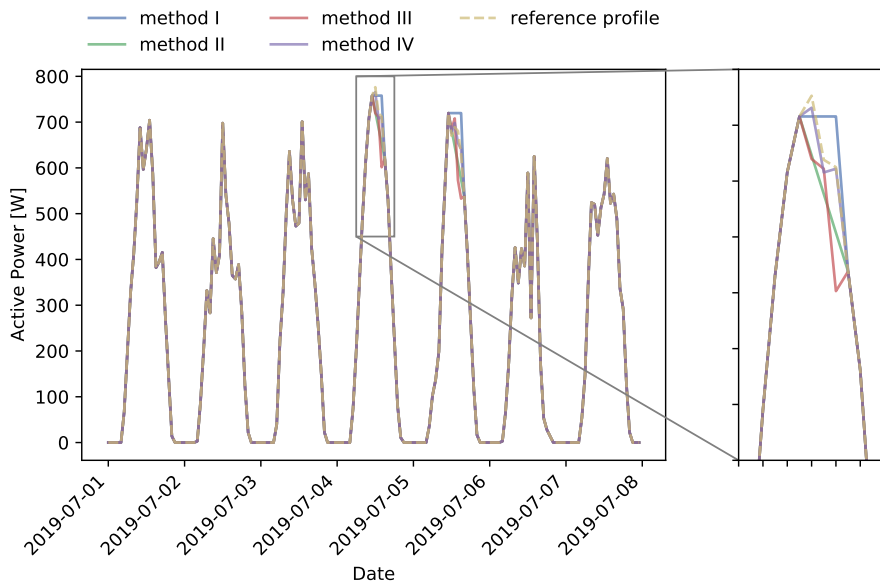

Figure 6.14: Comparing different baselining methods for curtailment option 2a.

profiles, baselining method II is therefore suitable.

When applying curtailment option 2 (a and b), method II tends to underestimate the reference profile, as can be observed in figures 6.14 and 6.15. This is inherent to the applied linearisation, in particular for smooth PV curves. Only in very specific weather conditions, with large fluctuations of PV output, method II might overestimate the reference profile. The performance of method II for curtailment option 2 (a and b) is better than for curtailment option 1. However, looking at the error metrics (table 6.3), overall baselining method I outperforms baselining method II.

Method III

Method III takes into account the last five days and uses the measurements of the three with the highest production. Looking at figure 6.13, this method seems to be approximating the reference profile relatively well in the first few days of the week. On the 4th of July, it can be observed that, due to the relatively low profiles of the past days, method III underestimates the reference profile.

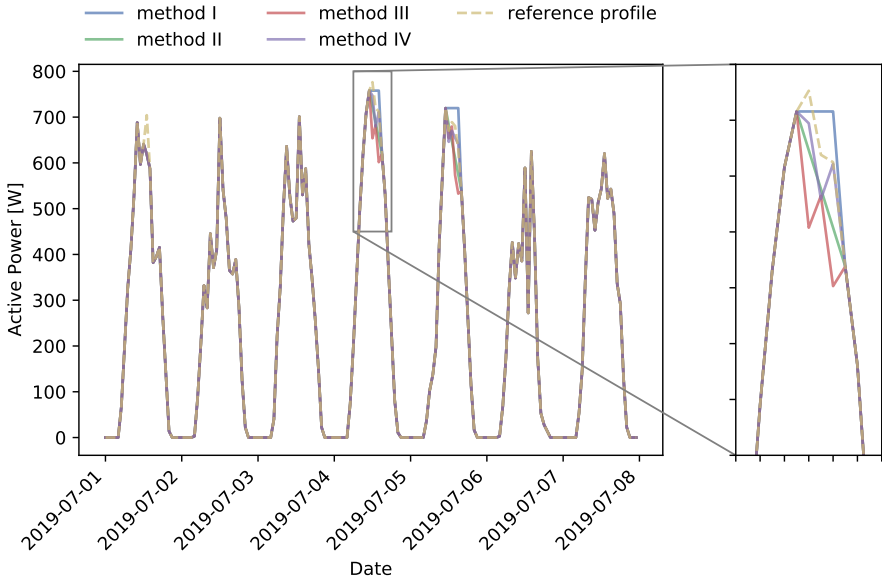

Figure 6.15: Comparing different baselining methods for curtailment option 2b.

Looking at curtailment option 2, method III is relatively sensitive to previous flexibility activation, as this influences the historical data used to construct the baseline. This can be observed clearly by comparing figure 6.14 with figure 6.15. Looking at the zoom-box of the fourth of July, the profile of baselining method III is changed significantly in the latter figure.

Method IV

The (new) method IV combines the historical data used in method III, with historical and actual irradiance measurements. As a result, the baseline is better able to follow the pattern of the reference profile. However, from figure 6.13, it can be observed that this is typically with a downward bias in case curtailment option 1 is applied. Compared with methods I, II and III, our new method shows an improvement in accuracy for all curtailment options. For curtailment option 2a and 2b, the profile has the highest accuracy, with a mean absolute error of maximum 4.27 W in the first week of August. Furthermore, the historical flexibility activations introduced in curtailment option 2b have less impact on the outcome of method IV compared to method III.

6.4.5 Error metric

For each of the three evaluated weeks, the mean absolute error (MAE) and root mean square error (RMSE) are determined (see section 6.3.5). The results are presented in table 6.3. For an additional three weeks, the error metrics can be found in appendix D⁴.

Comparing methods II and III, method III in general performs better. This method is based on the historical data, which can result in situations in which the opposite holds and the accuracy of method III is lower than the accuracy of method II. This is in particular the case for the first week of July, using curtailment option 2. Figure 6.14 shows that the first few days of July have a lower PV output. As these days are used to generate the baseline, this directly influences the result. In case of curtailment option 2b, this effect is increased due to flexibility activations being incorporated in the historical dataset.

It can be observed that overall, the performance of the new baselining method IV is better than that of methods I, II and III. Furthermore, the impact of the user dilemma on methods III and IV can be observed in curtailment option 2b. For these two methods, the error increases slightly when flexibility activation has occurred in the measurements of the historical days used to generate the baselines. This was to be expected, but the effect is relatively small, especially for method IV.

Overall it can be observed that the accuracy in weeks with volatile PV irradiance, like the first week of August, is significantly lower. This is because the historical data on which some of the baselines are based are strongly affected by this volatility. For curtailment option 1, the accuracy seems to decrease less during volatile weather, which can be explained by the lower amounts of flexibility activation.

The accuracy's dependency on the actual weather situation shows one of the trade-offs a DSO must be prepared to make. When implementing baselining methods that are simple and transparent, there situations during which the performance of those baselines is lower are inevitable. This is not necessarily problematic, as the expectation is that the majority of flexibility activations will be during peak PV production weeks. Should a DSO often need flexibility in weeks with volatile PV output, alternative, more complex baselining methods might be required.

⁴As the generation of curtailment profiles is done manually (see section 6.4.3), the number of analysed weeks is limited.

Table 6.3: Error metric for baselines in the first weeks of May, June and July, 2019. Units in [W].

	Option 1		Option 2a		Option 2b	
	MAE	RMSE	MAE	RMSE	MAE	RMSE
1-8 Jun						
Method I	9.00	31.44	3.47	18.78	3.47	18.78
Method II	15.87	60.75	8.80	52.65	8.80	52.65
Method III	12.31	44.86	5.27	29.84	5.64	30.45
Method IV	3.12	11.47	0.98	5.19	1.07	5.74
1-8 Jul						
Method I	30.19	80.34	1.86	10.05	2.37	12.03
Method II	29.27	75.44	1.92	10.07	2.43	12.04
Method III	19.22	56.71	2.45	14.83	3.49	18.45
Method IV	10.01	26.38	0.45	2.63	1.41	8.28
1-8 Aug						
Method I	7.61	40.53	4.71	36.14	4.71	36.14
Method II	9.37	45.37	4.85	36.28	4.85	36.28
Method III	8.54	43.29	4.34	35.78	4.34	35.78
Method IV	5.10	36.04	4.27	35.77	4.27	35.77

6.4.6 Discussion

The presented accuracy comparisons and error metrics are dependent on the used weather data, number and duration of flexibility requests and the magnitude of the curtailment. For a proof-of-concept of a newly developed transparent and simple method proposed in this chapter, three summer weeks with different profiles have been selected. Each week gives a different result, which is to be expected when weeks with different profiles are compared. In particular weeks with a highly volatile irradiance profile have a large impact on the error metric (i.e. result in a worse performance). The error metrics of three additional weeks are presented in appendix D. In future work, a broader statistical analysis is needed to ensure these results are valid in general.

As the baseline is equal to the measurement when no flexibility is activated, the amount and duration of flexibility requests also influences the baselining error. Increasing the number and/or duration of activations will increase the error of the baseline, as for those periods the baseline is no longer equal to the measurement (thus the error is no longer zero).

The error metrics should therefore not be interpreted in absolute sense. The MAE and RMSE provide a way to compare the four baselining methods, under the specific circumstances they have been tested for. This gives insight in their accuracy in similar situations. However, to get a better view, a simulation over a longer period of time would be required, including a platform to generate market-based flexibility activations.

When implementing a simulation over a longer period of time, including a platform to generate flexibility activations or requests, the availability of flexibility can also be taken into account. For this research, it is assumed that when flexibility is requested by the DSO, the market will offer it and the flexibility is indeed available at the moment of delivery. However, in a real-life situation, not every flexibility request may be fulfilled and not all promised flexibility will be delivered. The resulting uncertainty affects the baselines, as the historical measurements depend on the activation (no delivered flexibility means no user dilemma). This again impacts the performance.

For method IV, the baseline is scaled using weather data. As the DSO does not necessarily have the same weather dataset as market parties have, it is important to evaluate the impact of using different datasets for the applied scaling, including using weather data from different locations, which is likely to happen given the limited amount of weather stations in relation to the spread of PV systems. To explore this, a weather dataset from the other side of the city is used. As the difference in output for baselining method IV was <2.5 W, or $<1\%$, in this specific case the impact is negligible, but this topic also needs to be investigated further.

The new method IV introduces an improvement compared to baselining methods I, II and III, while still keeping the method as simple and transparent as possible. However, the accuracy improvement depends on the weather, and during periods with highly volatile irradiance profiles, the error may be higher. In case this is not acceptable, and a DSO is willing to compromise on the simplicity and transparency criteria, alternative methods might be considered (e.g. methods in the calculated or machine learning domain, see section 6.2.2). Alternatively, the DSO might implement a prognosis-based baseline. For this research, prognosis-based baselines are not considered, as the nature of the problem of determining a baseline is not solved by shifting this responsibility from the DSO to a market party (e.g. aggregator).

6.5 Conclusions

The research question answered with this chapter is: *How can DSOs settle the delivered flexibility with the market, ex-post, and what are suitable solutions to use in daily operation?* This chapter answers that question by evaluating four methods to baseline flexibility provided by PV systems. The methods are selected for their simplicity and transparency, two key criteria in order for DSOs and market parties to accept and implement a baselining solution. This is done for different curtailment strategies: curtailment of every peak above a threshold and day-ahead flexibility requests.

It is shown in this chapter that three existing methods have shortcomings in terms of accuracy, in particular when curtailing downward to a threshold value. A proof-of-concept is provided for a fourth method. It is shown that this method, while maintaining simplicity and transparency, performs better for the cases investigated in this chapter. In cases of high PV production and a relatively smooth irradiance profile, this method is preferable. The extent of improvement is however dependent on the volatility of the irradiance profile.

Future work consists of two main elements. First, the current research evaluates baselines based on three independent weeks with a limited set of flexibility activations. Future research considering longer periods of time and including more frequent flexibility activations is required to further explore the performance improvement brought by the new method. Second, the current methods are evaluated for PV systems only. Future work should evaluate whether other flexibility assets, in particular those with a strong dependency on a single parameter can be described by this method as well.

7 | Conclusions, contributions, and recommendations

The main research question of this thesis is introduced in chapter 1: *Which local flexibility mechanisms can DSOs use to unlock the necessary flexibility, and how can DSOs decide on daily operation and settlement of flexibility?* In order to answer this research question, five sub-questions are answered in their corresponding chapters. First, current developments related to flexibility in distribution networks are discussed, with a focus on a DSO perspective. Then, different flexibility mechanisms DSOs can use to unlock flexibility from the distribution networks are discussed. By introducing theoretical background on flexibility (chapter 2) and different possibilities to unlock flexibility (chapter 3), these two chapters provide an answer to the first part of the main research question. The remainder of the thesis focuses on insights derived from a demonstration project (chapter 4), a four-step approach proposed to operationalise flexibility in an every-day setting (chapter 5), and a baselining method to facilitate the settlement of delivered flexibility (chapter 6). Those three chapters and their respective sub-questions provide an answer to the second half of the research question.

This chapter is organised in two sections. The first section presents the main conclusions and contributions of this thesis. The second section presents the main recommendations for future research.

7.1 Conclusions and contributions

Gap between theory and practice

Until now, flexibility-related research has primarily focused on theory and simulations. Typically, there is a remaining gap between theory and practice, in particular for implementations in a real-life setting. An example of such gap is related to the separation of roles. Research and pilots so far often combine multiple roles into a single entity (e.g. BRP, supplier, and aggregator in one). This thesis shows that all roles can operate independently in a flexibility market. The separation of roles then gives market parties the choice to either operate a role independent (e.g. aggregator only), or combine multiple roles in a single entity (e.g. BRP and supplier). Defining independent roles also implies clearly defined and standardised interfaces between different roles are necessary, as for example is shown in the Dutch InterFlex sub-project.

There is currently a gap between theory and practice. This gap can be both technical (i.e. the systems, tools and/or steps that are needed to get an operational, real-live system up and running) and regulatory (i.e. the required changes in the regulatory framework to be allowed and able to apply flexibility solutions in an operational, real-live environment). Regarding the technical gap, this thesis shows the utilisation of flexibility for congestion management is possible in practice. This thesis furthermore provides a proof-of-concept for the required decision steps of the DSOs, both for the every-day operational application and the following settlement process. Regarding the regulatory gap, the Dutch system operators and regulator are in the process of redefining the regulatory framework for congestion management. This framework should then enable DSOs to start applying flexibility for congestion management in distribution networks.

Four-step approach

An integral framework is proposed to provide DSOs with tools to make every-day operational decisions as to where, when, and how much flexibility to utilise and request from the market. The research presented in this thesis shows this framework can be implemented as a generic four-step approach. The proposed steps are data acquisition, load forecasting, decision-making and flexibility mechanism interfacing. Making use of the load forecast, the decision-making algorithm takes the extent of (expected) overloading into account and translates this into a cost of component lifetime reduction of an overloading and financial risk of an outage. This way, a trade-off can be made between letting

an overloading occur or utilising flexibility. A case-specific implementation of the four-step approach, part of the Dutch InterFlex sub-project, provides a proof-of-concept.

By putting a financial value on the life-time reduction and financial risk of a power outage, the implementation shows that the DSO can compete with other markets in the procurement of flexibility. The financial value of the evaluated cases of overloading is competitive with the prices on the wholesale and balancing markets.

Certainty and reliability of flexibility

The results of the InterFlex sub-project show that DSOs need to consider the certainty with which flexibility is available and the reliability with which flexibility is provided. To ensure security of supply, both certainty of availability, and reliability of delivery are of paramount importance to DSOs. One way of increasing certainty and reliability is introducing long-term bilateral contracts with aggregators or customers. These contracts can furthermore be stacked with other flexibility mechanisms. Alternatively, direct control can be used, either as flexibility mechanism or as a fall-back mechanism. The need for long-term bilateral contracts and a fall-back mechanism in case of market failure is recognised by the Dutch system operators and are addressed in the the ongoing discussions on redefining the Dutch regulatory framework related to congestion management.

Value of flexibility

By taking the cost of component lifetime reduction and the financial risk of an outage into account, the DSO can carefully weigh when to use flexibility and when to accept overloading. There is an exponential relation between the extent of overloading and the lifetime reduction, and the lifetime reduction is larger for higher outdoor temperatures.

In some cases it is therefore cheaper for the DSO to let a congestion occur, rather than to mitigate it utilising flexibility. Especially when the overloading is limited to a few percent and the outdoor temperature is low (thus a limited cost of lifetime reduction), the market price of flexibility may exceed the value of flexibility for the DSO. Vice versa, when an overloading is significant (e.g. 140% of the rated transformer capacity) and the outdoor temperature is high, the combined cost of lifetime reduction and financial risk of overloading (thus the value of flexibility to the DSO) will be significantly higher than the typical market price of flexibility on competing markets (e.g. wholesale and balancing).

Baselining

Traditional baselining methods were typically applied at industrial customers with relatively predictable loads. These baselining methods can be characterised by their simple and transparent nature. Simplicity and transparency are identified as two key criteria in order for DSOs and market parties to accept and be able to implement a baselining method. Traditional baselining methods are however less suitable for variable flexibility sources, such as for example solar PV systems.

This thesis evaluates three existing (traditional) methods in combination with a solar PV system. It is shown that the three existing methods have shortcomings in terms of accuracy, in particular when PV systems are curtailed to a threshold value.

This thesis then presents a proof-of-concept for a fourth, novel method. It is shown that this novel method, while maintaining simplicity and transparency, performs better for the cases investigated in this thesis. The extent of improvement is however dependent on the volatility of the irradiance profile. In cases of high PV production and a relatively smooth irradiance profile, this method is better compared to the traditional methods.

Main contributions

The main contribution of this thesis can be summarised as follows. By integrating, adapting and expanding on existing research, this thesis proposes practical tools necessary to start utilising flexibility in daily operation to DSOs. These tools are integrated in a framework of a four-step approach and enables DSOs to request their flexibility needs from market parties. This thesis illustrates that the proposed concepts can work not only in theory, but can be adapted and used in a practical (pilot) context.

This thesis furthermore analyses the baselining challenge on the interface between a DSO and an aggregator. The limitations of three existing methods are demonstrated and a proof-of-concept of a newly developed method overcoming some of the limitations is provided as a fourth alternative, maintaining simplicity and transparency. This contributes to resolving the settlement challenge that is still remaining in many flexibility projects.

7.2 Recommendations

Operationalising flexibility

Currently the four-step approach to operationalise the DSOs flexibility needs uses a fixed algorithm for forecasting and decision-making. Future research should evaluate alternative models to include in the four-step approach, such that DSOs have the option to select the best model, considering the selected flexibility use case, either before or after running the models. To aid DSOs with picking the best model, it is furthermore recommended to provide a structured overview of the accuracy, computational intensity, complexity, stability, and input data dependence of these alternatives.

Operational decision-making

So far, research primarily focused on methods to unlock flexibility and use cases in which to utilise flexibility for e.g. congestion management. The challenges that come with every-day operational deployment of flexibility are a research direction that is relatively new. This thesis provides the tools the DSO needs to make the every-day decision on flexibility deployment and provides a proof-of-concept for the proposed methods.

Future work should expand on the research on operational decision making. This is a topic in which DSOs likely need to take the lead, bringing together industry and knowledge institutes to generalise solutions and overcome remaining gaps between theory and practice.

Baselining

Traditional baselining methods are less suitable for flexibility sources, as traditional baselining methods typically need predictable loads. This thesis evaluates three existing baselining methods and introduces a novel baselining method for application with solar PV systems. It is expected the proposed method can also be applied for other flexibility sources with a strong dependency on a single external parameter (for example heat pumps, in relation to the outdoor temperature). As part of future work on baselining, it should be evaluated whether these methods can be applied with other flexibility assets, both with and without a strong dependency on a single external parameter.

The baseline research presented in this thesis furthermore limits itself to providing a proof-of-concept, using six independent summer weeks with a limited set of flexibility activations. During future research longer periods of time

should therefore be considered and these periods should include more frequent flexibility activations. This should furthermore be extended by data sets of different locations and alternative weather data sets. These additional analysis should give a definitive answer on the limitations of existing baselining methods and the performance improvement brought by the new baselining method.

Additionally, one of the assumptions of the baselining research presented in this thesis is that aggregators always deliver the flexibility the DSO requests. The uncertainty on availability of flexibility during the moment of delivery is not included and is part of future work.

Standardisation and integration

In practice there is no one-size-fits-all solution for the application of flexibility for congestion management. There are many different flexibility sources and mechanisms, and each can be implemented in different ways and/or in parallel. The proposed solutions to unlock and settle flexibility therefore need to be tailored to each use case. Further research on different forecasting, decision-making, and baselining methods is required.

On the other hand, to ensure scalability and interoperability of (different) flexibility solutions, standardisation of systems, interfaces and protocols is necessary. DSOs therefore need a grid management system (GMS) in order to facilitate every-day operational deployment of flexibility. To enable large-scale application of flexibility for congestion management, further development and standardisation of a GMS and integrating the every-day operational flex procurement (the use of a GMS) in the DSO's organisation and processes is recommended.

A | Electric vehicle flexibility

This appendix elaborates on two technologies enabling flexibility from electric vehicle charging: smart charging and vehicle-to-grid. Both are briefly explained in the remainder of this appendix.

Smart charging

In 2015, the European Committee for Standardization (CEN), the European Committee for Electrotechnical Standardization (CENELEC) and the European Telecommunications Standards Institute (ETSI) wrote a report on EV smart charging, defining smart charging as: *"the charging of an EV controlled by bidirectional communication between two or more actors to optimise all customer requirements, as well as grid management and energy production including renewables with respect to system limitations, reliability, security and safety."* [178]. In other words, smart charging can be seen as a way to charge an EV, such that the objectives of multiple actors or stakeholders are met. This controlled charging results in flexibility.

Smart charging can be controlled through different ways. The USEF foundation identified three [42]:

- Charge point controlled charging;
- Car controlled charging;
- Home- or building management system controlled charging

Standardisation efforts for smart charging protocols have been made by (among others) ElaadNL. An overview of different smart charging protocols can be found in [147]. The focus of this overview is the application of EV

charging from a distribution network perspective. The study discusses protocols on different interfaces, such as between EV and charge point or between charge point and charge point operator.

Vehicle-to-grid

EVs have a battery on board to store the needed energy for transportation. This energy can however also be used to feed back into the power system, for example in case of shortages or congestion as a result of heavy loading. This concept is known as *vehicle-to-grid* or *vehicle2grid* (V2G). V2G can be used to exchange energy in different ways: to support the home power network, to exchange energy between EVs in a local EV community, or to feed back into the power system [179].

Tan et al. provide a review of various V2G technologies and applications, including advantages and challenges. One of the challenges identified is the limited availability of V2G-ready technology [179].

Like traditional EV charging, V2G availability comes with uncertainties. A statistical approach to assess the potential of V2G, the uncertainty of availability and its impact on the flexibility services is discussed in [180]. To this end, EV charging differentiates between home and work charging. It is found that work charging is more reliable, due to a lower uncertainty of connection times [180].

B | SGAM Dutch InterFlex sub-project

Due to the diversity of topics covered, smart grid projects have relatively complicated architecture models. The smart grid architectural model (SGAM) introduces a harmonised representation of the high-level architecture of the various aspects of smart grid projects.

SGAM uses a three dimensional model, with a two dimensional base pane. The base pane covers the different domains and zones of the power system. On the horizontal axis five domains (generation, transmission, distribution, DER, and customer premises) are covering the electrical energy conversion chain. On the vertical axis, different zones are representing the hierarchical levels for management of the power system (process, field, station, operation, enterprise, and market) [181].

The third dimension is created by adding various layers, describing the aspects of a smart grid. The bottom field provides the physical infrastructure of the smart grid (component layer), the remaining layers are covering the communication protocols, information exchange, main functions of clusters of infrastructure, and the business opportunities of the smart grid [181].

In order to not complicate the SGAM diagrams more than necessary, only the interactions between the different roles and systems as part of the pilot are visualised (e.g. interactions between DSO and aggregator). Interactions that are implicitly present are not visualised (e.g. interactions between TSO and aggregator).

In the remainder of this section, the five layers are discussed. Figure B.1 introduces the legend used in figures B.2, B.3, B.4, B.5, and B.6. Distribution automation (DA) and distribution automation light (DALI) are the names of the measurement systems used by the DSO responsible for the pilot area.

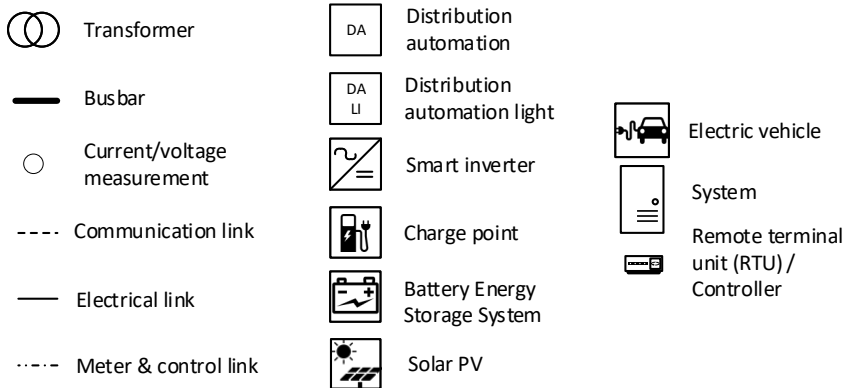

Figure B.1: SGAM legend

Component layer (figure B.2): In the process zone of the distribution domain (horizontal axis), a simplified representation of the pilot location's distribution network is provided. On various locations in the distribution network (e.g. feeders, MV/LV transformer), measurement equipment (DA and DALI) is integrated. The pilot setup continues in the DER and customer domains, where the DER are connected.

The various devices (e.g. distribution automation and DER inverters/charge points) in the process zone (vertical axis) are communicating with the outside world using remote terminal units (RTUs) or controllers. In the distribution domain, these RTUs are connected to the operational systems of the DSO (i.e. DaVinci, Datalake and SCADA/DMS). For the pilot setup, these operational systems are providing the GMS with measurements in the distribution level. In the DER domain, the RTUs are connected to the LIMS and to the CPMS. The LIMS and CPMS and the GMS are connected through a commercial aggregator party, using the system called the flexibility aggregator platform (FAP).

Communication layer (figure B.3): For the communication layer, two types of standards can be distinguished. On the one hand, a standard dictating the means of communication (the carrier, or the 'how') is described, on the other hand the standard dictating the messages exchanged (the content, or the 'what' and 'when').

Between the different systems within the operation, enterprise, and market zones, the communication carrier applied is Ethernet TCP/IP, both within a local network and over the internet. The DSO communicates with the distri-

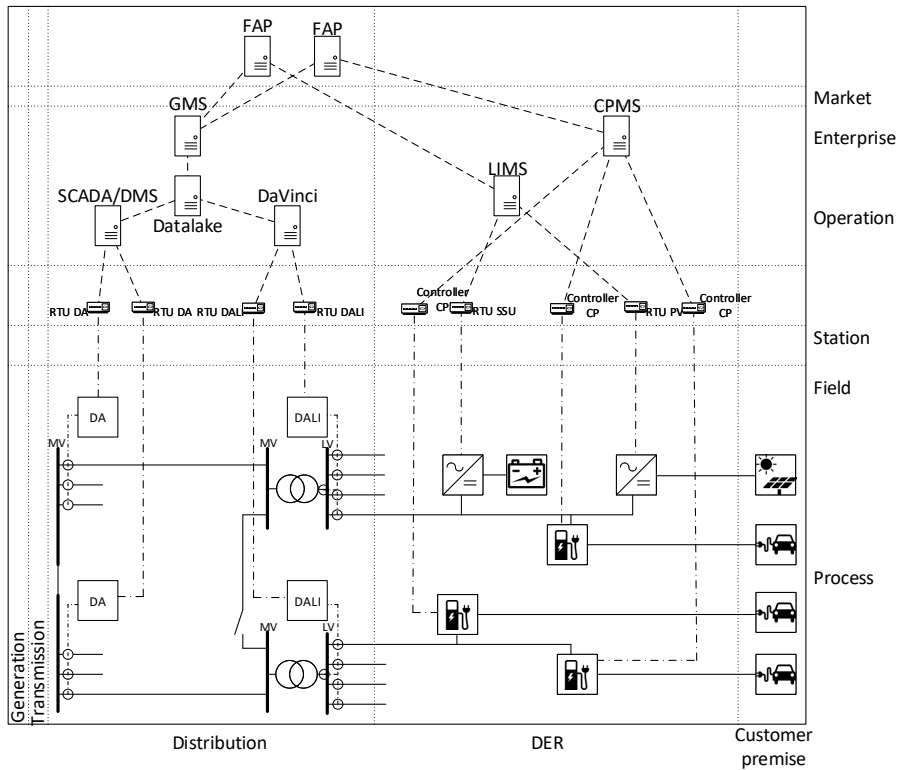

Figure B.2: SGAM component layer.

bution automation systems over the GRPS network, as does the CPMS with the underlying charge points.

As both DSO/distribution automation and the CPMS/charge points interaction are developed systems, the standards for the necessary exchange of messages is also known already. For the DSO's distribution automation, IEC 60870-5-104 is applied. The CPMS and charge points communicate with the open charge point protocol (OCPP). The market framework implemented between GMS, FAP and LIMS/CPMS is USEF. The interaction between LIMS and the underlying DER (or flexibility sources) is mostly case-specific and/or proprietary. This implies that adding additional flexibility sources likely results in the need of additional protocols to control these flexibility sources.

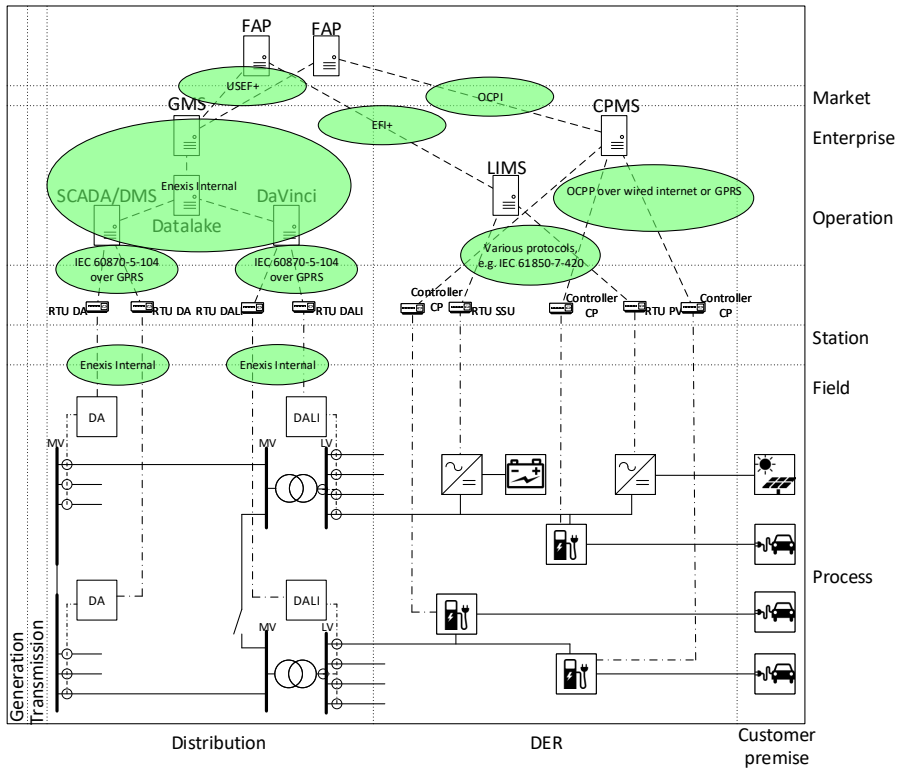

Figure B.3: SGAM communication layer.

Information layer (figure B.4): The relevant information is exchanged in the station zone and above. The DSO’s operational systems obtain measurement data from the distribution automation systems. This information in turn is provided to the GMS. Between GMS, FAP and CPMS/LIMS the information exchange focuses on the trading of flexibility and is dictated by the adaptation of USEF and EFI. Between CPMS/LIMS and flexibility sources, case-specific information is exchanged (e.g. state of charge, duration of charging).

Function layer (figure B.5): The function layer provides a high-level overview of the pilot’s functional blocks. Four blocks can be distinguished: data acquisition, flex procurement for grid management purposes, flexibility/DER aggregation and trading, and DER control.

The central functional block of the DSO contains the GMS, which main

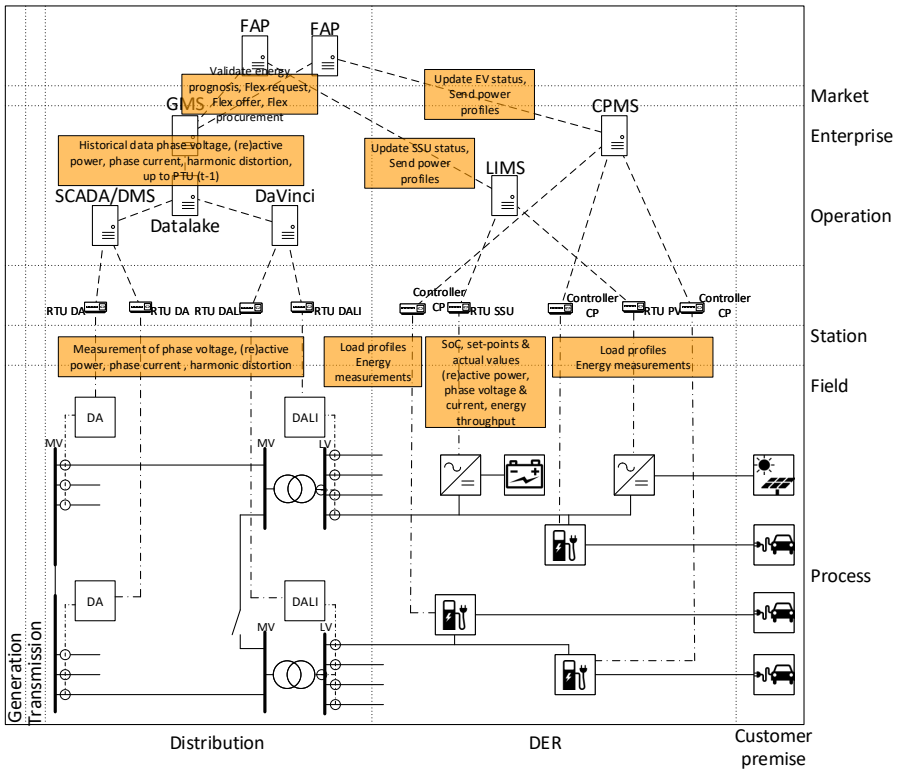

Figure B.4: SGAM information layer.

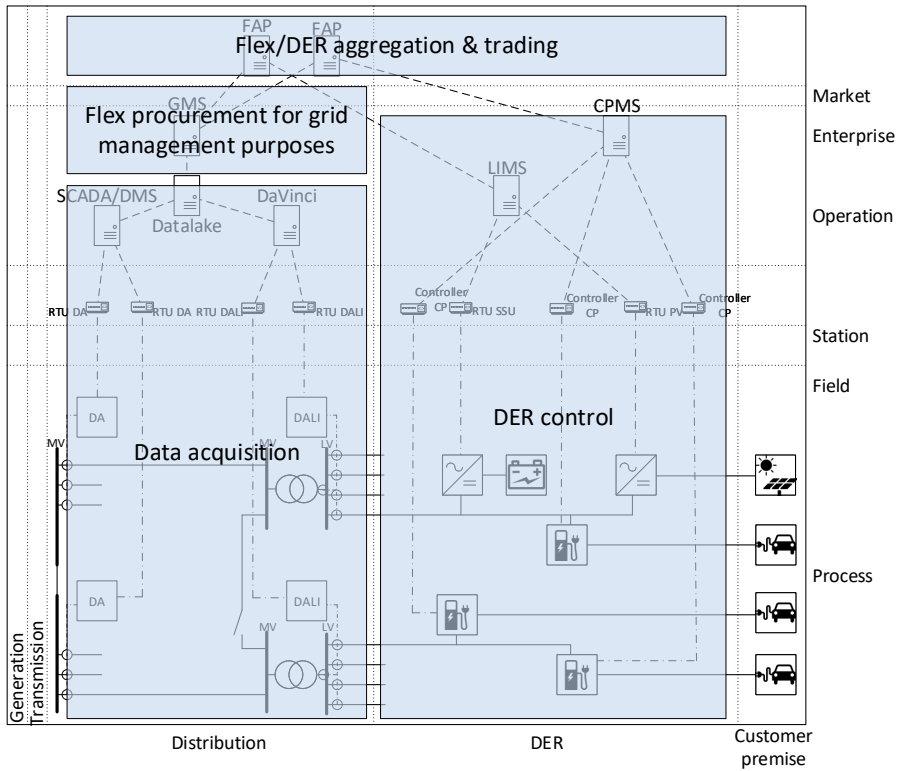

Figure B.5: SGAM function layer.

function is to procure flexibility for grid management purposes. This system interfaces with the DSO’s operational systems for data acquisition, and with the commercial aggregator for flexibility aggregation and trading.

The commercial aggregator in turn interfaces with the local (flexibility) aggregator, and (outside the scope of this SGAM diagram) with the TSO/BRP and/or other energy markets to trade all available flexibility.

Business layer (figure B.6): The previous levels of the SGAM diagram result in the following business layer with three roles and their interactions: DSO, commercial aggregator, and local aggregator. Between those actors two main business transactions can be distinguished: flex trading between DSO and commercial aggregator, and flex asset provision and procurement between commercial- and local aggregator.

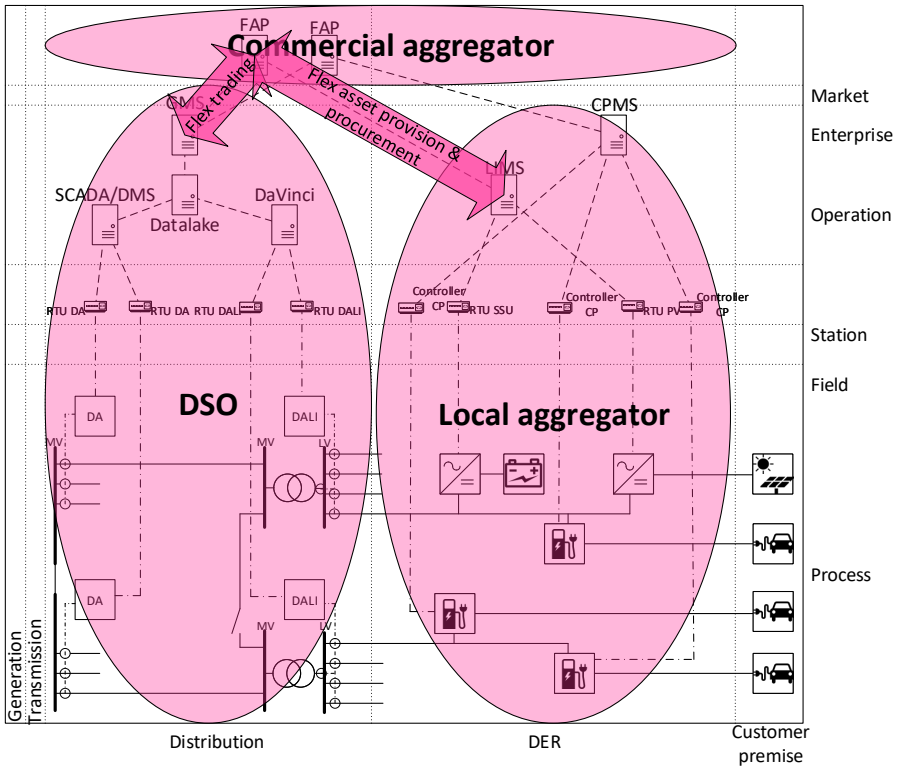

Figure B.6: SGAM business layer.

C | Baseline practices in literature

Table C.1: Overview of the different baseline analysis in literature. Categories according to section 6.2.

Category	Reference	Description
Window before	[160]	Window before
Window before and after	[173] [165]	4rd order polynomial interpolation Average of the last measurement before and first measurement after the activation window
Prognosis	[71, 156, 182] [183]	USEF so-called D-Prognosis, which an aggregator provides to the DSO ahead-of-time A so called self-reported baseline mechanism, which forces an aggregator to share its forecast and unit cost with the DSO
Historical	[159, 184] [159, 184] [159, 184]	10-day historical average Weighted average using previous 20 admissible days Average over highest 3/10 previous admissible days

Category	Reference	Description
	[159, 184]	Average over highest 5/10 previous admissible days
	[163]	Highest and lowest x/y
	[163]	Exponential moving average (produces the weighed average of customer's consumption)
	[185]	Highest x/y: New York ISO method
	[185]	Exponential moving average: New England ISO method
	[173]	Highest x/y
	[173]	Last y days
	[167]	Average consumption over past 10 days
	[160]	Historical interval meter data, considering weather and calendar data
	[160]	Behind the meter method, based on output levels of the flexibility asset
Calculated	[159, 184]	Seasonal regression baseline
	[159, 184]	Limited seasonal regression baseline
	[159, 184]	10-day regression baseline
	[186]	Exponential smoothing regression model
	[161, 162]	Regression-based baseline
	[163]	Linear regression, incl. historical consumption, sunset/sunrise, temperature as explanatory variables
	[187]	Gaussian process based probabilistic baseline estimation
	[185]	Multiple linear regression
	[173]	Non-linear regression
	[167]	Gaussian process based
	[167, 188]	Similar day, taking into account the temperature pattern in a part of the day
	[160]	Statistical sampling to estimate consumption

Category	Reference	Description
Machine learning	[189]	Regression based, using 5-minute interval measurements, and using ambient temperature and solar irradiance as predictors
	[172]	Unsupervised learning based on self-organising map and k-means clustering
	[173]	Neural network-based
	[174]	Probabilistic baseline estimation using deep learning-based deep embedded clustering
	[175]	Stacked & cooperating auto-encoder based, using expansion methods on the small training dataset
Control group	[164]	Control group based on selecting individual load profiles to be as close as possible to the target profile
	[169]	Statistical analysis to cluster similar customers to then fit event days with the profile of the cluster
	[190]	Virtually defined set of customers not currently participating in DR.
Combinations/other	[167]	Weighed average of historical data, combined with preset control group
	[165]	Combined window before and historical: avg. of 5 out of 10 highest corresponding hours on days before, corrected for avg. difference 2 hours before activation
	[165]	Combined window before and historical: equal to previous hour, corrected with fraction of increase from day before
	[160]	Drop-to method

D | Additional error metrics

An additional analysis of error metrics has been made for the week of 15-22 May 2019, 15-22 June 2019, and 15-22 July 2019. For curtailment option 1, all loads higher than the curtailment limit (i.e. 578 W) is curtailed to the limit. For curtailment option 2 (a and b) loads exceeding 578 W are curtailed to 578 W on 15-19 May/June/July between 12:00-16:00. Additionally, for curtailment option 2b, loads exceeding 578 W are curtailed to 578 W on 13-14 May/June/July. The error metrics for these weeks can be found in table D.1.

As discussed in section 6.4.5, the performance of method III strongly depends on historical measurements. In periods of stable weather, method III generally outperforms method II, while method II and III perform relatively similar in case the historical irradiance is less stable. This can also be seen in table D.1.

Similar to the results from table 6.3, table D.1 shows method IV overall performs best, compared to methods I, II and III. The error of method IV is in all simulated weeks improved compared to the traditional baselining methods.

Table D.1: Error metric for baselines in the middle weeks of May, June and July, 2019. Units in [W].

	Option 1		Option 2a		Option 2b	
	MAE	RMSE	MAE	RMSE	MAE	RMSE
15-22 May						
Method I	13.17	54.98	2.49	16.44	2.49	16.44
Method II	13.54	54.43	4.36	24.73	4.36	24.73
Method III	8.52	37.09	3.63	23.25	3.92	21.97
Method IV	4.93	20.76	0.94	5.98	2.97	16.80
15-22 Jun						
Method I	19.99	65.16	9.17	48.62	9.17	48.62
Method II	19.10	65.83	7.43	41.28	7.43	41.28
Method III	19.31	63.12	10.72	51.69	10.72	51.69
Method IV	2.86	9.66	0.90	4.58	0.90	4.58
15-22 Jul						
Method I	3.61	26.79	1.71	15.64	1.71	15.64
Method II	2.66	23.55	1.32	12.74	1.32	12.72
Method III	5.38	33.03	1.48	13.80	1.48	13.80
Method IV	1.97	22.72	0.90	11.39	0.90	11.39

Bibliography

- [1] J. Frunt, “Analysis of Balancing Requirements in Future Sustainable and Reliable Power Systems,” Ph.D. dissertation, Eindhoven University of Technology, 2011. Available: <http://repository.tue.nl/711271>
- [2] P. van Oirsouw, *Netten voor distributie van elektriciteit*. Arnhem, the Netherlands: Phase to phase, 2011. Available: <https://phasetophase.nl/boek/index.html>
- [3] J. Evans and L. C. Hunt, *International Handbook on the Economics of Energy*. MPG Books Group, UK, 2009.
- [4] B. D. Solomon and K. Krishna, “The coming sustainable energy transition: History, strategies, and outlook,” *Energy Policy*, vol. 39, no. 11, 2011. Available: <http://dx.doi.org/10.1016/j.enpol.2011.09.009>
- [5] United Nations, “Our Common Future,” United Nations, Tech. Rep., 1987.
- [6] EC. 2020 climate & energy package. Available: https://ec.europa.eu/clima/policies/strategies/2020_en Accessed on: 2020-12-17.
- [7] EC. Paris Agreement. Available: https://ec.europa.eu/clima/policies/international/negotiations/paris_en Accessed on: 2020-12-17.
- [8] EC. (2020) 2030 climate & energy framework. Available: https://ec.europa.eu/clima/policies/strategies/2030_en Accessed on: 2020-12-17.
- [9] EC. 2050 long-term strategy. Available: https://ec.europa.eu/clima/policies/strategies/2050_en Accessed on: 2020-12-17.

- [10] BP, “Statistical Review of World Energy,” BP, Tech. Rep., 2020. Available: <https://www.bp.com/content/dam/bp/business-sites/en/global/corporate/pdfs/energy-economics/statistical-review/bp-stats-review-2020-full-report.pdf>
- [11] O. Ellabban, H. Abu-Rub, and F. Blaabjerg, “Renewable energy resources: Current status, future prospects and their enabling technology,” *Renewable and Sustainable Energy Reviews*, vol. 39, 2014. Available: <http://dx.doi.org/10.1016/j.rser.2014.07.113>
- [12] S. Pirani, J. Stern, and K. Yafimava, “The Russo-Ukrainian gas dispute of January 2009: a comprehensive assessment,” Oxford Institute for Energy Studies, Oxford, Tech. Rep., 2009. Available: <http://www.oxfordenergy.org/wpcms/wp-content/uploads/2010/11/NG27-TheRussoUkrainianGasDisputeofJanuary2009AComprehensiveAssessment-JonathanSternSimonPiraniKatjaYafimava-2009.pdf>
- [13] S. Ellenbeck, A. Beneking, A. Ceglaz, P. Schmidt, and A. Battaglini, “Security of supply in european electricity markets-determinants of investment decisions and the European Energy Union,” *Energies*, vol. 8, no. 6, 2015.
- [14] Eurostat. (2019) Glossary:Renewable energy sources - Statistics Explained. Available: https://ec.europa.eu/eurostat/statistics-explained/index.php/Glossary:Renewable_energy_sources Accessed on: 2020-12-17.
- [15] Eurostat. (2020) Share of energy from renewable sources. Available: https://ec.europa.eu/eurostat/databrowser/view/NRG_IND_REN__custom_366392/default/table?lang=en Accessed on: 2020-12-17.
- [16] Eurostat. (2020) Electricity production capacities by main fuel groups and operator. Available: https://ec.europa.eu/eurostat/databrowser/view/NRG_INF_EPC__custom_366344/default/table?lang=en Accessed on: 2020-12-17.
- [17] CBS. Zonnepanelen; vermogen bedrijven en woningen. Available: <https://opendata.cbs.nl/statline/#/CBS/nl/dataset/84518NED/table?dl=1DE74> Accessed on: 2020-12-17.
- [18] CBS. Windenergie; elektriciteitsproductie, capaciteit en windaanbod. Available: <https://opendata.cbs.nl/statline/#/CBS/nl/dataset/70802NED/table?fromstatweb> Accessed on: 2020-12-17.

- [19] E. J. Coster, J. M. A. Myrzik, B. Kruimer, and W. L. Kling, "Integration issues of distributed generation in distribution grids," *Proceedings of the IEEE*, vol. 99, no. 1, 2011.
- [20] J. E. S. de Haan, "Cross-border balancing in Europe : ensuring frequency quality within the constraints of the interconnected transmission system," Ph.D. dissertation, Eindhoven University of Technology, 2016.
- [21] CBS. (2020) Bijna 200 duizend stekkerauto's. Available: <https://www.cbs.nl/nl-nl/nieuws/2020/16/bijna-200-duizend-stekkerauto-s> Accessed on: 2020-12-17.
- [22] ACM. Gasaansluitplicht. Available: <https://www.acm.nl/nl/onderwerpen-energie-netbeheerders/gasaansluitplicht> Accessed on: 2020-12-17.
- [23] CBS. (2020) Warmtepompen; aantallen, thermisch vermogen en energiestromen. Available: <https://www.cbs.nl/nl-nl/cijfers/detail/82380NED> Accessed on: 2020-12-17.
- [24] Klimaatakkoord. Afspraken voor de gebouwde omgeving. Available: <https://www.klimaatakkoord.nl/gebouwde-omgeving> Accessed on: 2020-12-17.
- [25] E. A. M. Klaassen, "Demand response benefits from a power system perspective," Ph.D. dissertation, Eindhoven University of Technology, 2016.
- [26] C. Kobus, "A switch by design: User-centred design of smart energy technologies to change habits of using energy at home," Ph.D. dissertation, Delft University of Technology, 2016.
- [27] ENTSO-E, "The Harmonised Electricity Market Role Model," ENTSO-E, Tech. Rep., 2020. Available: https://eepublicdownloads.entsoe.eu/clean-documents/EDI/Library/HRM/Harmonised_Role_Model_2020-01.pdf
- [28] ENTSO-E. ENTSO-E Member Companies. Available: <https://www.entsoe.eu/about/inside-entsoe/members/> Accessed on: 2020-12-17.
- [29] Eurelectric, "Power Distribution in Europe: Facts & Figures," Eurelectric, Tech. Rep., 2013.

- [30] Overzicht Netbeheerders Elektriciteit en Gas in Nederland. Available: <https://www.energieleveranciers.nl/netbeheerders/overzicht-netbeheerders> Accessed on: 2021-01-19.
- [31] K. Kotilainen, "Energy Prosumers' Role in the Sustainable Energy System," Ph.D. dissertation, Tampere University of Technology, 2020.
- [32] TenneT, "Flexibility Roadmap," TenneT, Tech. Rep., 2018. Available: https://www.tennet.eu/fileadmin/user_upload/Company/Publications/Technical_Publications/Dutch/FlexibilityRoadmapNL.pdf
- [33] S. C. Bhattacharyya, *Energy Economics*. London: Springer London, 2011. Available: <http://link.springer.com/10.1007/978-0-85729-268-1>
- [34] L. Boscán and R. Poudineh, *Business Models for Power System Flexibility: New Actors, New Roles, New Rules*. Elsevier Inc., 2016. Available: <http://dx.doi.org/10.1016/B978-0-12-804249-6/00019-1>
- [35] L. Kane and G. Ault, "A review and analysis of renewable energy curtailment schemes and Principles of Access: Transitioning towards business as usual," *Energy Policy*, vol. 72, 9 2014. Available: <http://dx.doi.org/10.1016/j.enpol.2014.04.010><https://linkinghub.elsevier.com/retrieve/pii/S0301421514002213>
- [36] International Energy Agency, "Harnessing Variable Renewables: A Guide to the Balancing Challenge," International Energy Agency, Tech. Rep., 2011. Available: www.iea.org
- [37] ENTSO-E, CEDEC, GEODE, EURELECTRIC, and EDSO for Smart Grids, "TSO-DSO Data Management Report," ENTSO-E, Tech. Rep., 2015.
- [38] Eurelectric, "Flexibility and aggregation - requirements for their interaction in the market," Eurelectric, Tech. Rep., 2014. Available: http://www.eurelectric.org/media/115877/tf_balagr_report_final_je_as-2014-030-0026-01-e.pdf
- [39] C. Eid, P. Codani, Y. Perez, J. Reneses, and R. Hakvoort, "Managing electric flexibility from Distributed Energy Resources: A review of incentives for market design," *Renewable and Sustainable Energy Reviews*, vol. 64, 2016. Available: <http://dx.doi.org/10.1016/j.rser.2016.06.008>

- [40] ElaadNL, “Waar rijden én laden EV’s in de toekomst?” ElaadNL, Tech. Rep., 2019.
- [41] ElaadNL. ElaadNL Open Datasets for Electric Mobility Research | Update April 2020. Available: https://platform.elaad.io/analyses/ElaadNL_opendata.php Accessed on: 2021-01-19.
- [42] USEF Foundation and Jedlix, “Case study - Practical Development of Electric Vehicle Flexibility,” USEF & Jedlix, Tech. Rep., 2020.
- [43] Enexis. (2020) Gebieden met schaarste voor teruglevering op het energienet. Available: <https://www.enexis.nl/zakelijk/duurzaam/bepaalde-capaciteit/gebieden-met-schaarste> Accessed on: 2021-04-15.
- [44] Liander. (2021) Beschikbaarheid capaciteit per gebied. Available: <https://www.liander.nl/transport-schaarste/beschikbaarheid-capaciteit> Accessed on: 2020-12-17.
- [45] Stedin. (2020) Beschikbare netcapaciteit. Available: <https://www.stedin.net/zakelijk/congestiemanagement-en-transportprognoses/beschikbare-netcapaciteit> Accessed on: 2020-12-17.
- [46] Netbeheer Nederland. (2021) Beantwoording wijzigingsopdracht. Available: <https://www.acm.nl/sites/default/files/documents/voorstel-codewijziging-herziening-congestiemanagement.pdf> Accessed on: 2021-04-17.
- [47] Netbeheer Nederland. (2021) Capaciteitskaart invoeding elektriciteitsnet. Available: <https://capaciteitskaart.netbeheernederland.nl> Accessed on: 2021-04-19.
- [48] F. R. Segundo Sevilla, D. Parra, N. Wyrsh, M. K. Patel, F. Kienzle, and P. Korba, “Techno-economic analysis of battery storage and curtailment in a distribution grid with high PV penetration,” *Journal of Energy Storage*, vol. 17, 6 2018.
- [49] P. Wiest, K. Rudion, and A. Probst, “Optimization of Power Feed-In Curtailment from RES and its Consideration within Grid Planning,” in *PowerTech 2017*, 2017.
- [50] H. Marthinsen, A. Z. Morch, M. Plecas, I. Kockar, and M. Dzamarija, “Aggregation Model for Curtailable Generation and Sheddable Loads,” in *CIREN 2017*, 2017.

- [51] T. L. Vandoorn, L. Degroote, P. Lindeboom, D. Meire, and L. Van-develde, "Pilot Project Using Curtailment To Increase the Renewable Energy Share on the Distribution Network," in *CIREC 2017*, 2017.
- [52] R. Fonteijn, T. van Cuijk, P. H. Nguyen, J. Morren, and J. G. Slootweg, "Flexibility for congestion management: A demonstration of a multi-mechanism approach," in *Innovative Smart Grid Technologies - Europe (ISGT-Europe), 2018 IEEE*, 2018. Available: <https://doi.org/10.1109/ISGTEurope.2018.8571896>
- [53] J. Koskela, K. Lummi, A. Mutanen, A. Rautiainen, and P. Jarventausta, "Utilization of Electrical Energy Storage With Power-Based Distribution Tariffs in Households," *IEEE Transactions on Power Systems*, vol. 34, no. 3, 5 2019. Available: <https://ieeexplore.ieee.org/document/8523809/>
- [54] Enpuls, "Lessons Learnt," Enpuls, Tech. Rep., 2017.
- [55] S. Bhattacharyya, T. van Cuijk, and R. Fonteijn, "Integrating smart storage and aggregators for network congestion management & voltage support in a pilot project," in *25th International Conference on Electricity Distribution (CIGRE)*, Madrid, 2019. Available: <https://doi.org/20.500.12455/94>
- [56] R. de Groot, "Optimal placement and operation of novel grid technologies in distribution grids," Ph.D. dissertation, Eindhoven University of Technology, 2017.
- [57] Vattenfall. Power plants: Prinses Alexia Windpark. Available: <https://powerplants.vattenfall.com/prinses-alexia> Accessed on: 2021-02-03.
- [58] N. Belonogova, V. Tikka, S. Honkapuro, J. Lassila, J. Partanen, P. Heine, A. Pihkala, H.-P. Hellman, M. Hyvärinen, J. Karppinen, K. Siilin, J. Matilainen, and M. Laasonen, "Multi-Objective Role of Battery Energy Storages in an Energy System," in *Proceedings of the CIGRE Workshop*, 2018.
- [59] C. Brivio, S. Mandelli, and M. Merlo, "Battery energy storage system for primary control reserve and energy arbitrage," *Sustainable Energy, Grids and Networks*, vol. 6, 2016. Available: <http://dx.doi.org/10.1016/j.segan.2016.03.004>

- [60] H. M. Lopes Ferreira, "Integration of energy storage in power systems," Ph.D. dissertation, Eindhoven University of Technology, 2017.
- [61] I. Dincer and M. A. Rosen, "Heat Pump Systems," in *Exergy Analysis of Heating, Refrigerating and Air Conditioning*. Elsevier, 2015.
- [62] G. Rouwhorst, "The flexibility potential to reduce the peak load of small and medium-sized enterprises," Master's thesis, Eindhoven University of Technology, 2019.
- [63] G. Rouwhorst, R. Fonteijn, A. Brouwer, P. Nguyen, and H. Slootweg, "The flexibility potential to reduce the peak load of small and medium enterprises," in *CIREN 2020 Berlin Workshop*. CIREN, 2020.
- [64] R. Morales González, M. Gibescu, S. Cobben, M. Bongaerts, M. de Nes-Koedam, and W. Vermeiden, "Demand Response of Medical freezers in a Business Park Microgrid," in *Smartgreens 2018 - 7th conference on Smart Cities and Green ICT Systems2*, 2018.
- [65] BZO Community-flex, "Populaire samenvatting eindrapport 'BZO Community-flex'," BZO Community-flex, Tech. Rep., 2020. Available: <https://www.enexisgroep.nl/media/2995/samenvatting-rapportage-bzo-community-flex.pdf>
- [66] GRID4EU, "Final Report - Grid4EU project," GRID4EU, Tech. Rep., 2016.
- [67] Nordic Council of Ministers, *Demand side flexibility in the Nordic electricity market*. Nordic Council of Ministers, 2017.
- [68] E. A. Klaassen, Y. Zhang, I. Lampropoulos, and J. G. Slootweg, "Demand Side Management of Electric Boilers," in *2012 3rd IEEE PES Innovative Smart Grid Technologies Europe (ISGT Europe)*, 2012.
- [69] Alliander, Essent, IBM, ICT, NRG031, Heerhugowaard, and Energiekoplopers, "De flexibiliteit van huishoudelijk stroomverbruik: Een nieuwe markt met kansen," Energiekoplopers, Tech. Rep., 2016. Available: https://www.energiekoplopers.nl/wp-content/uploads/2016/11/EnergieKoplopers_eindrapport.pdf
- [70] C. Srithapon, P. Ghosh, A. Siritariwat, and R. Chatthaworn, "Optimization of electric vehicle charging scheduling in urban village networks considering energy arbitrage and distribution cost," *Energies*, vol. 13, no. 2, 2020.

- [71] USEF Foundation, "USEF: The Framework Explained," USEF, Brussels, Tech. Rep., 2015.
- [72] USEF Foundation, "USEF: The Framework Explained - update May 2021," USEF, Tech. Rep., 2021.
- [73] M. van Amstel, "Flexibility system design for electric vehicles. Performing congestion management for the DSO," PDEng thesis, University of Twente, 2018.
- [74] J.F.G. Cobben, *Power Quality - Problems and Solutions*. Arnhem, the Netherlands: CO-ED, 2012.
- [75] D. Steber, M. Pruckner, P. Bazan, and R. German, "SWARM - Providing 1 MW FCR Power with Residential PV-Battery Energy Storage - Simulation and Empiric Validation," in *PowerTech 2017*, 2017.
- [76] J. Jomaux, T. Mercier, and E. D. Jaeger, "Provision of Frequency Containment Reserves with Batteries and Power-to-Heat," in *PowerTech 2017*, 2017.
- [77] ElaadNL. Frequency Containment Reserve Pilot projects - Elaad NL. Available: <https://www.elaad.nl/projects/frequency-containment-reserve-pilot/> Accessed on: 2021-01-22.
- [78] Next Kraftwerke. Next Kraftwerke en Jedlix lanceren initiatief waarbij batterijen van elektrische auto's worden gebruikt voor net stabiliteit. Available: <https://www.next-kraftwerke.be/nl/next-kraftwerke-en-jedlix-lanceren-initiatief-waarbij-batterijen-van-elektrische-autos-worden-gebruikt-voor-net-stabiliteit/> Accessed on: 2021-01-22.
- [79] K. Bassett, R. Carriveau, and D. S. Ting, "Energy arbitrage and market opportunities for energy storage facilities in Ontario," *Journal of Energy Storage*, vol. 20, 12 2018.
- [80] Vattenfall. (2016) Primeur: Prinses Alexia Windpark start met opslag van windenergie - Vattenfall NL. Available: <https://group.vattenfall.com/nl/newsroom/archive/nieuws/2016/primeur-prinses-alexia-windpark-start-met-opslag-van-windenergie> Accessed on: 2020-12-17.
- [81] Enpuls, "PEAKSHAVING PILOT ALTWEERTERHEIDE Eindrapport," Enpuls, Tech. Rep., 2020.

- [82] A. Kulmala, S. Repo, and J. Pylvänäinen, "Generation Curtailment as a Means to Increase the Wind Power Hosting Capacity of a Real Regional Distribution Network," in *CIREC 2017*, 2017.
- [83] R. Bernards, "Smart planning," Ph.D. dissertation, Eindhoven University of Technology, 2018.
- [84] N. Blaauwbroek, "Flexibility in active distribution network management: a new horizon in monitoring and control for grid supportive demand side management," Ph.D. dissertation, Eindhoven University of Technology, 2018.
- [85] A. N. M. M. Haque, P. H. Nguyen, F. W. Blik, and J. G. Slootweg, "Demand response for real-time congestion management incorporating dynamic thermal overloading cost," *Sustainable Energy, Grids and Networks*, vol. 10, 2017. Available: <http://dx.doi.org/10.1016/j.segan.2017.03.002>
- [86] H. J. Liu, L.-y. Lu, and Z. Wu, "Distributed Optimization Approach for Frequency Control with Emulated Virtual Inertia in Islanded Microgrids," in *2018 IEEE Innovative Smart Grid Technologies - Asia (ISGT Asia)*, 2018.
- [87] Eurelectric, "Demand Response: Everything you always wanted to know about," Eurelectric, Tech. Rep., 2015.
- [88] SEDC, "Explicit and Implicit Demand-Side Flexibility Complementary Approaches for an Efficient Energy System," Smart Energy Demand Coalition, Tech. Rep., 2016.
- [89] R. Fonteijn, M. van Amstel, P. H. Nguyen, J. Morren, G. M. Bonnema, and J. G. Slootweg, "Evaluating flexibility values for congestion management in distribution networks within Dutch pilots," *The Journal of Engineering*, vol. 2019, no. 18, 7 2019. Available: <https://doi.org/10.1049/joe.2018.9314><https://digital-library.theiet.org/content/journals/10.1049/joe.2018.9314>
- [90] GOPACS. (2019) GOPACS. Available: <https://en.gopacs.eu/> Accessed on: 2020-12-17.
- [91] M. Farrokhsersht, "The coupled market: Unlocking the potential of distributed energy resources in the electricity market," Ph.D. dissertation, Eindhoven University of Technology, 2021.

- [92] J. Villar, R. Bessa, and M. Matos, "Flexibility products and markets: Literature review," *Electric Power Systems Research*, vol. 154, 2018. Available: <https://doi.org/10.1016/j.epsr.2017.09.005>
- [93] P. Olivella-Rosell, P. Lloret-Gallego, I. Munne-Collado, R. Villafafila-Robles, A. Sumper, S. O. Ottessen, J. Rajasekharan, and B. A. Bremdal, "Local flexibility market design for aggregators providing multiple flexibility services at distribution network level," *Energies*, vol. 11, no. 4, 2018.
- [94] P. Olivella-Rosell, E. Bullich-Massague, M. Aragües-Penalba, A. Sumper, S. O. Ottesen, J.-A. Vidal-Clos, and R. Villafafila-Robles, "Optimization problem for meeting distribution system operator requests in local flexibility markets with distributed energy resources," *Applied Energy*, vol. 210, 2018.
- [95] P. Olivella-rosell, "Local Electricity Markets Design and Operation in Distribution Power Systems," Ph.D. dissertation, Universitat Politècnica de Catalunya, 2019.
- [96] S. Minniti, N. Haque, P. Nguyen, and G. Pemen, "Local Markets for Flexibility Trading: Key Stages and Enablers," *Energies*, vol. 11, no. 11, 2018. Available: <http://www.mdpi.com/1996-1073/11/11/3074>
- [97] C. Dumbs, G. Jarry, M. Willems, T. Gross, A. Larsen, and T. Wagner, "Market Models For Local Flexibility Procurement: Interflex' Experience And Main Challenges," in *25th International Conference on Electricity Distribution (CIRED)*, 2019. Available: <https://cired-repository.org/handle/20.500.12455/756>
- [98] T. Schittekatte and L. Meeus, "Flexibility markets: Q&A with project pioneers," *Utilities Policy*, vol. 63, 2020. Available: <https://doi.org/10.1016/j.jup.2020.101017>
- [99] G. Koreneff, L. Similä, J. Forsström, E. Rinne, C. Schöpfer, J. Segerstam, S. Repo, and O. Kilkki, "Local flexibility markets: Smart Otaniemi D4.1," VTT, Tech. Rep., 2020. Available: <https://cris.vtt.fi/en/publications/local-flexibility-markets-smart-otaniemi-d41>
- [100] Smart Otaniemi. (2021) Smart Otaniemi » Pilots. Available: <https://smartotaniemi.fi/pilots/> Accessed on: 2021-02-15.

- [101] K. Mäki, S. Horsmanheimo, and P. Kupila, “Data Platform As An Enabler For Smart Otaniemi Ecosystem Innovation ecosystem Present research platform,” in *25th International Conference on Electricity Distribution (CIRED)*, 2020.
- [102] ACM. (2021) Meettarief | ACM.nl. Available: <https://www.acm.nl/nl/onderwerpen/energie/afnemers-van-energie/energietarieven/meettarief> Accessed on: 2021-02-17.
- [103] L. van Cappellen, “Variable network tariffs in the LV-network,” Master’s thesis, Eindhoven University of Technology, 2019.
- [104] A. Faruqi and S. Sergici, “Household Response to Dynamic Pricing: A Survey of The Experimental Evidence,” The Brattle Group, Tech. Rep., 2009.
- [105] Z. Hu, J. H. Kim, J. Wang, and J. Byrne, “Review of dynamic pricing programs in the U.S. And Europe: Status quo and policy recommendations,” *Renewable and Sustainable Energy Reviews*, vol. 42, 2015. Available: <http://dx.doi.org/10.1016/j.rser.2014.10.078>
- [106] C. Eid, E. Koliou, M. Valles, J. Reneses, and R. Hakvoort, “Time-based pricing and electricity demand response: Existing barriers and next steps,” *Utilities Policy*, vol. 40, 2016. Available: <http://dx.doi.org/10.1016/j.jup.2016.04.001>
- [107] F. Kühnlenz, P. H. J. Nardelli, S. Karhinen, and R. Svento, “Implementing Flexible Demand: Real-time Price vs. Market Integration,” *Energy*, vol. 149, 2017. Available: <http://arxiv.org/abs/1709.02667>
- [108] A. Rautiainen, K. Lummi, A. Supponen, J. Koskela, S. Repo, P. Järventausta, S. Honkapuro, J. Partanen, J. Haapaniemi, J. Lassila, J. Haakana, and N. Belonogova, “Reforming Distribution Tariffs of Small Customers - Targets, Challenges and Impacts of Implementing Novel Tariff Structures,” in *CIRED 2017*, 2017.
- [109] K. Lummi, A. Rautiainen, P. Jarventausta, P. Heine, J. Lehtinen, M. Hyvarinen, and J. Salo, “Alternative Power-Based Pricing Schemes for Distribution Network Tariff of Small Customers,” in *2018 IEEE Innovative Smart Grid Technologies - Asia (ISGT Asia)*. IEEE, 5 2018. Available: <https://ieeexplore.ieee.org/document/8467793/>

- [110] E. A. M. Klaassen, C. B. A. Kobus, J. Frunt, and J. G. Slootweg, "Responsiveness of residential electricity demand to dynamic tariffs: Experiences from a large field test in the Netherlands," *Applied Energy*, vol. 183, 2016. Available: <http://dx.doi.org/10.1016/j.apenergy.2016.09.051>
- [111] C. B. A. Kobus, E. A. M. Klaassen, R. Mugge, and J. P. L. Schoormans, "A real-life assessment on the effect of smart appliances for shifting households' electricity demand," *Applied Energy*, vol. 147, 2015. Available: <http://dx.doi.org/10.1016/j.apenergy.2015.01.073>
- [112] O. Erdiñç, A. Tascikaraoglu, N. G. Paterakis, and J. P. S. Catalao, "An Energy Credit Based Incentive Mechanism for the Direct Load Control of Residential HVAC Systems Incorporation in Day-Ahead Planning," in *PowerTech 2017*, 2017.
- [113] R. Tang, S. Wang, and K. Shan, "Optimal and near-optimal indoor temperature and humidity controls for direct load control and proactive building demand response towards smart grids," *Automation in Construction*, vol. 96, 12 2018.
- [114] R. Tang, S. Wang, and C. Yan, "A direct load control strategy of centralized air-conditioning systems for building fast demand response to urgent requests of smart grids," *Automation in Construction*, vol. 87, 3 2018.
- [115] S. Yilmaz, X. Xu, D. Cabrera, C. Chanez, P. Cuony, and M. K. Patel, "Analysis of demand-side response preferences regarding electricity tariffs and direct load control: Key findings from a Swiss survey," *Energy*, vol. 212, 12 2020.
- [116] E. Beshr and A. A. Raouf Mohamed, "Development of a Demand Response Program: A Case Study of Cairo, Egypt," in *Proceedings - 2018 53rd International Universities Power Engineering Conference, UPEC 2018*. Institute of Electrical and Electronics Engineers Inc., 11 2018.
- [117] ENTSO-E, CEDEC, GEODE, EURELECTRIC, and EDSO, "TSO-DSO Report: An integrated approach to active system management," ENTSO-E, Tech. Rep., 2019.
- [118] T. van Cuijk, R. Fonteijn, D. Geelen, J. Laarakkers, P. Rademakers, B. Ran, O. Westerlaken, M. Willems, K. van Zuuren, and K. van

- Zwienen, “Innovative solutions to be tested in the use cases,” H2020 InterFlex project deliverable D7.3, Tech. Rep., 2018.
- [119] A. N. M. M. Haque, M. Nijhuis, G. Ye, P. H. Nguyen, F. W. Bliet, and J. G. Slootweg, “Integrating Direct and Indirect Load Control for Congestion Management in LV Networks,” *IEEE Transactions on Smart Grid*, vol. 10, no. 1, 2017.
- [120] C. Dumbs, G. Jarry, D. Laffaille, S. Hes, D. Panic, I. Leisse, and J. Bruschi, “Flexibility For DSO On A Local Scale: Business Models And Associated Regulatory Questions Raised In The InterFlex Project,” in *Proceedings of the CIREN Workshop*, 2018.
- [121] R. Fonteijn, D. Geelen, P. Klapwijk, J. Laarakkers, P. Rademakers, B. Ran, O. Westerlaken, and M. Willems, “UC planning, District architecture requirements and tested innovations,” H2020 InterFlex project deliverable D7.1/D7.2, Tech. Rep., 2017.
- [122] Allecijfers. Informatie Buurt Strijp-S. Available: <https://allecijfers.nl/buurt/strijp-s-eindhoven> Accessed on: 2021-03-12.
- [123] R. Steegh, T. van Cuijk, and H. Pourasghar Khomami, “Grid Management System to solve local congestion,” in *25th International Conference on Electricity Distribution (CIREN), Madrid*, 2019.
- [124] B. Ran, W. Wijbrandi, J. Laarakkers, J. Nutma, and M. Klever, “Maximizing the utilization of DERs with the Interflex Aggregation Platform for Flexibility,” in *25th International Conference on Electricity Distribution (CIREN), Madrid*, 2019.
- [125] Flexiblepower Alliance Network. Energy Flexibility Interface. Available: <https://fan-ci.sensorlab.tno.nl/builds/fpai-documentation/development/html/EFI.html> Accessed on: 2017-08-31.
- [126] Enexis, TNO, ElaadNL, Croonwolter&dros, Jedlix, and Sympower, “Raw demonstration results based on the KPI measurements of the Dutch demo,” H2020 InterFlex project deliverable D7.7, Tech. Rep., 2019.
- [127] J. Nutma, W. Wijbrandi, B. Ran, and J. Laarakkers, “Interoperability for an Open Energy Flexibility Market With Congestion Management Services,” in *25th International Conference on Electricity Distribution (CIREN), Madrid*, 2019.

- [128] R. Fonteijn, M. H. Roos, P. Nguyen, J. Morren, and J. G. Sloopweg, "The Strijp-S living-lab: Testing innovative solutions for fault protection, self-healing, congestion management, and voltage control," in *University Power Engineering Conference*, 2018. Available: <https://doi.org/10.1109/UPEC.2018.8542117>
- [129] USEF Foundation, "USEF Flexibility Trading Protocol Specifications," USEF, Tech. Rep., 2020.
- [130] M. Roos, R. Fonteijn, P. Nguyen, J. Morren, and J. Sloopweg, "The Strijp-S living lab for embedded microgrid studies," in *CIREC workshop 2018*, 2018. Available: <https://doi.org/20.500.12455/1251>
- [131] M. Zweistra, E. van Aalzum, J. Laarakkers, K. van Zwiene, M. Willems, D. Geelen, R. Steegh, P. Klapwijk, R. Fleskens, O. Westerlaken, R. Fonteijn, and M. Postmus, "Lessons learned from use case #2 and #3," H2020 InterFlex project deliverable D7.6, Tech. Rep., 2019.
- [132] D. Geelen, N. Refa, and R. Spiering, "Smart Charging Electric Vehicles Based on a Flexibility Market," in *25th International Conference on Electricity Distribution (CIREC)*, 2019.
- [133] GOPACS. (2021) How does GOPACS work. Available: <https://en.gopacs.eu/about-gopacs-copy/> Accessed on: 2021-04-27.
- [134] GOPACS. (2021) FAQ GOPACS. Available: <https://en.gopacs.eu/faq-frequently-asked-questions/> Accessed on: 2021-04-27.
- [135] Enexis. (2020) Enexis Netbeheer en Liander Onderzoeken Potentie van Dimmen Zonneparken. Available: <https://www.enexisgroep.nl/nieuws/enexis-netbeheer-en-liander-onderzoeken-potentie-van-dimmen-zonneparken/> Accessed on: 2021-04-23.
- [136] Netbeheer Nederland. (2020) Flexibiliteit: Pieken aftopen. Available: https://www.netbeheernederland.nl/_upload/Files/Netcapaciteit_60_7e3b5c70b2.pdf Accessed on: 2021-04-23.
- [137] C. Kuster, Y. Rezgui, and M. Mourshed, "Electrical load forecasting models: A critical systematic review," *Sustainable Cities and Society*, vol. 35, 2017. Available: <http://dx.doi.org/10.1016/j.scs.2017.08.009>

- [138] R. Sevlian and R. Rajagopal, "A scaling law for short term load forecasting on varying levels of aggregation," *International Journal of Electrical Power and Energy Systems*, vol. 98, 2018.
- [139] P. Nijhuis, "Electricity demand forecasting at low voltage level for smart charging electric vehicles," Master's thesis, Eindhoven University of Technology, 2013.
- [140] L. Ren, L. Zhang, H. Wang, and Q. Guo, "An Extreme Gradient Boosting Algorithm for Short-Term Load Forecasting Using Power Grid Big Data," in *Proceedings of 2018 Chinese Intelligent Systems Conference*. Springer Singapore, 2019. Available: <http://link.springer.com/10.1007/978-981-13-2291-4>
- [141] G. Dudek, "Short-Term Load Forecasting Using Random Forests," in *Intelligent Systems'2014*, 2015. Available: <http://link.springer.com/10.1007/978-3-319-11310-4>
- [142] W. Kong, Z. Y. Dong, Y. Jia, D. J. Hill, Y. Xu, and Y. Zhang, "Short-Term Residential Load Forecasting based on LSTM Recurrent Neural Network," *IEEE Transactions on Smart Grid*, vol. 3053, 2017.
- [143] R. Hu, S. Wen, Z. Zeng, and T. Huang, "A short-term power load forecasting model based on the generalized regression neural network with decreasing step fruit fly optimization algorithm," *Neurocomputing*, vol. 221, 2017. Available: <http://dx.doi.org/10.1016/j.neucom.2016.09.027>
- [144] N. Mohan, K. P. Soman, and S. Sachin Kumar, "A data-driven strategy for short-term electric load forecasting using dynamic mode decomposition model," *Applied Energy*, vol. 232, 2018. Available: <https://doi.org/10.1016/j.apenergy.2018.09.190>
- [145] T. Castelijn, "DALI box Data Analytics to facilitate the Energy Transition," PDEng thesis, Eindhoven University of Technology, 2019.
- [146] A. N. M. M. Haque, "Smart Congestion Management in Active Distribution Networks," Ph.D. dissertation, Eindhoven University of Technology, 2017. Available: https://pure.tue.nl/ws/files/76305173/20170927_Haque.pdf
- [147] ElaadNL, "EV Related Protocol Study," ElaadNL, Arnhem, Tech. Rep., 2016. Available: https://www.elaad.nl/uploads/files/EV_related_protocol_overview_v1.0.pdf

- [148] R. Fonteijn, T. Castelijn, M. Grond, P. H. Nguyen, J. Morren, and J. G. Slootweg, "Short-term load forecasting on MV/LV transformer level," in *25th International Conference on Electricity Distribution (CIRED), Madrid*, 2019. Available: <https://doi.org/20.500.12455/65>
- [149] Facebook Prophet. Available: <https://facebook.github.io/prophet/> Accessed on: 2018-12-31.
- [150] IEEE Standard C57.91-2011, IEEE Standards Association, and IEEE Standard C57.91-2011, *IEEE Guide for Loading Mineral-Oil-Immersed Transformers and Step-Voltage Regulators*. IEEE, 2012, vol. 2011. Available: <http://ieeexplore.ieee.org/stamp/stamp.jsp?tp=&arnumber=6166928>
- [151] R. Fonteijn, R. Bernard, P. H. Nguyen, J. Morren, and J. G. Slootweg, "Flexibility for congestion management: an operational decision-making process," in *25th International Conference on Electricity Distribution (CIRED), Madrid*, 2019. Available: <https://doi.org/20.500.12455/53>
- [152] Smart Energy Demand Coalition, "Mapping Demand Response in Europe Today," Smart Energy Demand Coalition, Brussels, Tech. Rep., 2014. Available: http://www.febeliec.be/web/infosessionstrategiecdemandreserve_16_5_2014/1011306087/list1187970122/f1.html%5Cnhttp://sedc-coalition.eu/wp-content/uploads/2014/04/SEDC-Mapping_DR_In_Europe-2014-04111.pdf
- [153] S. Nolan and M. O'Malley, "Challenges and barriers to demand response deployment and evaluation," *Applied Energy*, vol. 152, 2015. Available: <http://dx.doi.org/10.1016/j.apenergy.2015.04.083>
- [154] I. Lampropoulos, "A System Perspective to the Deployment of Flexibility through Aggregator Companies," Utrecht University, Topsector Energie & TenneT, Tech. Rep., 2016.
- [155] Y. Chen, W. S. Lin, F. Han, Y. H. Yang, Z. Safar, and K. J. Liu, "A cheat-proof game theoretic demand response scheme for smart grids," *IEEE International Conference on Communications*, 2012.
- [156] USEF Foundation, "USEF: Workstream On Aggregator Implementation Models," USEF, Tech. Rep., 2017.

- [157] D. Muthirayan, E. Baeyens, P. Chakraborty, K. Poolla, and P. P. Khargonekar, "A Minimal Incentive-based Demand Response Program With Self Reported Baseline Mechanism," *IEEE Transactions on Smart Grid*, vol. PP, 2019. Available: <https://ieeexplore.ieee.org/document/8882298/>
- [158] D. Muthirayan, D. Kalathil, K. Poolla, and P. Varaiya, "Mechanism Design for Demand Response Programs," *IEEE Transactions on Smart Grid*, vol. 11, no. 1, 1 2020. Available: <https://ieeexplore.ieee.org/document/8716566/>
- [159] K. Coughlin, M. A. Piette, G. Charles, and S. Kiliccote, "Estimating Demand Response Load Impacts: Evaluation of Baseline Load Models for Non- Residential Buildings in California," Berkeley National Laboratory, Tech. Rep., 2008.
- [160] N. Rossetto, "Measuring the Intangible: An Overview of the Methodologies for Calculating Customer Baseline Load in PJM," Florence School of Regulation, Tech. Rep., 2018.
- [161] J. L. Mathieu, P. N. Price, S. Kiliccote, and M. A. Piette, "Quantifying changes in building electricity use, with application to demand response," *IEEE Transactions on Smart Grid*, vol. 2, no. 3, 2011.
- [162] J. L. Mathieu, D. S. Callaway, and S. Kiliccote, "Examining uncertainty in demand response baseline models and variability in automated responses to dynamic pricing," *Proceedings of the IEEE Conference on Decision and Control*, 2011.
- [163] T. K. Wijaya, M. Vasirani, and K. Aberer, "When bias matters: An economic assessment of demand response baselines for residential customers," *IEEE Transactions on Smart Grid*, vol. 5, no. 4, 2014.
- [164] L. Hatton, P. Charpentier, and E. Matzner-Lober, "Statistical Estimation of the Residential Baseline," *IEEE Transactions on Power Systems*, vol. 31, no. 3, 2016.
- [165] L. Sadovica, V. Lavrinovics, A. S. Sauhats, G. Junghans, and K. M. Lehtmet, "Estimating Energy Reduction Amount in the Event of Demand Response Activation: Baseline Model Comparison for the Baltic States," in *2018 15th International Conference on the European Energy Market (EEM)*, vol. 2018-June. IEEE, 6 2018. Available: <https://ieeexplore.ieee.org/document/8469796/>

- [166] Smart Grid Task Force, "Regulatory Recommendations for the Deployment of Flexibility - EG3 REPORT," Smart Grid Task Force, Tech. Rep., 2015.
- [167] B. Xia, H. Ming, K.-Y. Lee, Y. Li, Y. Zhou, S. Bansal, S. Shakkottai, and L. Xie, "Energycoupon: A case study on incentive-based demand response in smart grid," in *Proceedings of the Eighth International Conference on Future Energy Systems - e-Energy '17*. New York, New York, USA: ACM Press, 2017. Available: <http://dl.acm.org/citation.cfm?doid=3077839.3077862>
- [168] C. Ziras, C. Heinrich, and H. W. Bindner, "Why baselines are not suited for local flexibility markets," *Renewable and Sustainable Energy Reviews*, vol. 135, 1 2021. Available: <https://doi.org/10.1016/j.rser.2020.110357><https://linkinghub.elsevier.com/retrieve/pii/S1364032120306456>
- [169] Y. Zhang, W. Chen, R. Xu, and J. Black, "A Cluster-Based Method for Calculating Baselines for Residential Loads," *IEEE Transactions on Smart Grid*, vol. 7, no. 5, 2016.
- [170] TenneT. (2020) Balancing responsibility. Available: <https://www.tennet.eu/electricity-market/dutch-market/balancing-responsibility/> Accessed on: 2021-01-13.
- [171] X. Zhou, N. Yu, W. Yao, and R. Johnson, "Forecast load impact from demand response resources," *IEEE Power and Energy Society General Meeting*, vol. 2016-Novem, 2016.
- [172] S. Park, S. Ryu, Y. Choi, J. Kim, and H. Kim, "Data-driven baseline estimation of residential buildings for demand response," *Energies*, vol. 8, no. 9, 2015.
- [173] J. Jazaeri, T. Alpcan, R. Gordon, M. Brandao, T. Hoban, and C. Seeling, "Baseline methodologies for small scale residential demand response," *IEEE PES Innovative Smart Grid Technologies Conference Asia*, 2016.
- [174] M. Sun, Y. Wang, F. Teng, Y. Ye, G. Strbac, and C. Kang, "Clustering-based residential baseline estimation: A probabilistic perspective," *IEEE Transactions on Smart Grid*, vol. 10, no. 6, 2019.
- [175] X. Wang, Y. Wang, J. Wang, and D. Shi, "Residential Customer Baseline Load Estimation Using Stacked Autoencoder With Pseudo-Load Selection," *IEEE Journal on Selected Areas in Communications*, vol. 38, no. 1, 1 2020. Available: <https://ieeexplore.ieee.org/document/8892548/>

- [176] A. P. Dobos, "PVWatts Version 5 Manual (NREL/TP-6A20-62641)," National Renewable Energy Laboratory (NREL), Tech. Rep., 2014.
- [177] ADDRESS project. (2009) ADDRESS glossary. Available: http://www.addressfp7.org/index.html?topic=project_glossary# Accessed on: 2021-08-23.
- [178] CEN-CENELEC-ETSI, "E-Mobility Smart Charging: Report about Smart Charging of Electric Vehicles in relation to Smart Grid," CEN-CENELEC-ETSI, Tech. Rep., 2015. Available: <ftp://ftp.cen.eu/EN/EuropeanStandardization/HotTopics/ElectricVehicles/SmartChargingReport.pdf>
- [179] K. M. Tan, V. K. Ramachandaramurthy, and J. Y. Yong, "Integration of electric vehicles in smart grid: A review on vehicle to grid technologies and optimization techniques," *Renewable and Sustainable Energy Reviews*, vol. 53, 2016. Available: <http://dx.doi.org/10.1016/j.rser.2015.09.012>
- [180] S. Sarabi, A. Davigny, V. Courtecuisse, Y. Riffonneau, and B. Robyns, "Potential of vehicle-to-grid ancillary services considering the uncertainties in plug-in electric vehicle availability and service/localization limitations in distribution grids," *Applied Energy*, vol. 171, 2016. Available: <http://dx.doi.org/10.1016/j.apenergy.2016.03.064>
- [181] CEN/CENELEC/ETSI Joint Working Group on Standards for Smart Grids, "CEN-CENELEC-ETSI Smart Grid Coordination Group: Smart Grid Reference Architecture," CENELEC, Tech. Rep., 2012. Available: <ftp://ftp.cen.eu/EN/EuropeanStandardization/HotTopics/SmartGrids/Security.pdf>
- [182] E. Klaassen, M. van der Laan, H. de Heer, A. van der Veen, and W. van den Reek, "Flexibility Value Stacking," USEF Foundation, Tech. Rep., 2018.
- [183] D. Muthirayan, D. Kalathil, K. Poolla, and P. Varaiya, "Baseline Estimation and Scheduling for Demand Response," in *2018 IEEE Conference on Decision and Control (CDC)*. IEEE, 12 2018. Available: <https://ieeexplore.ieee.org/document/8619236/>
- [184] K. Coughlin, M. A. Piette, C. Goldman, and S. Kiliccote, "Statistical analysis of baseline load models for non-residential buildings," *Energy and Buildings*, vol. 41, no. 4, 2009.

- [185] S. Mohajeryami, M. Doostan, and P. Schwarz, "The impact of Customer Baseline Load (CBL) calculation methods on Peak Time Rebate program offered to residential customers," *Electric Power Systems Research*, vol. 137, 2016. Available: <http://dx.doi.org/10.1016/j.epsr.2016.03.050>
- [186] Y. M. Wi, J. H. Kim, S. K. Joo, J. B. Park, and J. C. Oh, "Customer baseline load (CBL) Calculation using exponential smoothing model with weather adjustment," *Transmission and Distribution Conference and Exposition: Asia and Pacific, T and D Asia 2009*, 2009.
- [187] Y. Weng and R. Rajagopal, "Probabilistic baseline estimation via Gaussian process," *IEEE Power and Energy Society General Meeting*, 2015.
- [188] H. Ming, B. Xia, K. Y. Lee, A. Adepoju, S. Shakkottai, and L. Xie, "Prediction and assessment of demand response potential with coupon incentives in highly renewable power systems," *Protection and Control of Modern Power Systems*, vol. 5, no. 1, 2020.
- [189] E. M. Larsen, A. H. Jónasdóttir, and K. R. Rosenørn, "Baselines For Evaluating Demand Response In The Ecogrid 2.0 Project," in *25th International Conference on Electricity Distribution (CIRED)*, 2019.
- [190] E. Lee, K. Lee, H. Lee, E. Kim, and W. Rhee, "Defining virtual control group to improve customer baseline load calculation of residential demand response," *Applied Energy*, vol. 250, 2019. Available: <https://doi.org/10.1016/j.apenergy.2019.05.019><https://linkinghub.elsevier.com/retrieve/pii/S0306261919308724>

List of Figures

- 1.1 Schematic overview of a traditional power system. 2
- 1.2 Increase in installed capacity of wind and solar PV in the EU. . . 4
- 1.3 Increase in installed capacity of wind and solar PV in the Netherlands. 5
- 1.4 Increase in numbers of electric vehicles in the Netherlands. . . . 6
- 1.5 Increase in numbers of heat pumps in the Netherlands. 7
- 1.6 Schematic outline of the thesis and the relationship between chapters and sub-questions (SQ). 12

- 2.1 Example of load shifting. 16
- 2.2 Example of curtailment of a solar PV profile. 17
- 2.3 Overview of feed-in congestion in the Netherlands. Red indicates no transport capacity is available, orange indicates the potential for congestion management is under review and yellow indicates limited transport capacity is available. Source figure: [47]. 20
- 2.4 Schematic overview of the energy flows in a heat pump. 21

- 3.1 Overview of the flexibility mechanisms discussed in this chapter. The mechanisms 'markets' and 'tariffs' are divided in different subcategories. 30
- 3.2 Illustration of the variable connection capacity concept and its related parameters. 40

- 4.1 Geographic overview of the pilot location. 50

4.2	Overview of the pilot implementation. The following abbreviations are used: DSO – distribution system operator, EVCPs – electric vehicle charge points, BESS – battery energy storage system, PV – photovoltaic, HHs – households.	51
4.3	Overview of the roles, systems, and interactions in the pilot implementations. The following abbreviations are used: DSO - distribution system operator (role), GMS - grid management system (system), FAP - flexibility aggregation platform (system), CA - commercial aggregator (role), LIMS - local infrastructure management system (system), LA - local aggregator (role), BESS - battery energy storage system (system), PV - photovoltaic (system), EVCPs - electric vehicle charge points (system).	55
4.4	Typical example of MV distribution rings with normally open point (NOP) during operation.	57
4.5	High-level topology of congestion points (MV/LV transformer) and their outgoing feeders. The types of connections/loads are indicated per feeder. The feeders 'Shared facilities' connect the loads of the apartment building (e.g. elevators). The used abbreviations are PV (photo-voltaic), BESS (battery energy storage system) and EVCP (electric vehicle charge point).	59
5.1	Steps to operationalise flexibility for DSO application.	68
5.2	Example of the error visualisation.	74
5.3	XGBoost regression model performance for one of the two congestion points in the Dutch InterFlex demonstrator. For the afternoon hours, the RMSE improves with a difference of over 10 kW, comparing the model including weather features and decomposition with the model excluding weather features and decomposition.	82
5.4	Cost of lifetime reduction per percentage overloading for different outdoor temperatures. Figure generated using the lifetime reduction and total lifetime cost model, without considering time-dependence.	84
5.5	Linearized financial risk of overloading.	85
5.6	Cumulative probability function of difference between day-ahead market and (downward) balancing market prices.	87
5.7	Load forecast of a week in June 2019, congestion point 1.	89
5.8	Load forecast of a week in June 2019, congestion point 2.	89

5.9	Transformer load profile for August 2018 (summer). The assumed transformer capacity (rated power) is set at 100 kW.	91
5.10	Value of flexibility (overloading cost) [€/MWh] for the transformer overloading in August 2018, in relation to the day-ahead market and balancing market prices at the time. For each PTU in which flexibility is requested, the value of flexibility to the DSO, and the prices on the imbalance and day-ahead market are plotted.	91
5.11	Forecasted load profile (forecast of inflexible loads, aggregator prognosis of EV and battery storage, and combination or total of both) for last week of June 2019 (summer). The assumed transformer capacity (rated power) is set at 115 kW.	93
5.12	Flexibility need for last week of June 2019 (summer).	93
5.13	Value of flexibility (overloading cost) [€/MWh] for the transformer overloading in June 2019, in relation to the day-ahead market and balancing market prices at the time. The assumed transformer capacity is set at 115 kW.	94
5.14	Value of flexibility (overloading cost) [€/MWh] for the transformer overloading in June 2019, in relation to the day-ahead market and balancing market prices at the time. The assumed transformer capacity is set at 130 kW.	94
5.15	Screenshot of the grid management system's online portal, showing an overview of the congestion points in the region and their respective status.	95
5.16	Screenshot of the details of a specific congestion point. The amount of PTUs in which congestion occurs and the amount of PTUs in which congestion is solved can be observed. On the right-hand side, the steps (messages) of the interactions with the market can be found.	96
6.1	Precision and bias in relation to the criterion accuracy.	102
6.2	Overview of the implementation flow of the different baselining methodologies.	113
6.3	Illustration of baseline I and its activation period. The dashed line reflects the baseline.	115
6.4	Illustration of baseline II and its variables. The dashed line reflects the baseline.	116
6.5	Illustration of baseline III and its variables. The necessary data is taken per timestep, for the previous y days. As only x out of y historical days are included, not all historical values are needed.	117

6.6	Illustration of baseline IV and its variables. The necessary data for \bar{P}_t is taken per timestep, for the previous y days. The necessary data for \bar{I}_t is taken for the exact same days used for \bar{P}_t . As only x out of y historical days are included, not all historical values are needed.	118
6.7	Comparison of forecasted and measured irradiance data during the first week of June 2019.	119
6.8	Comparison of forecasted and measured irradiance data during the first week of July 2019.	120
6.9	Comparison of forecasted and measured irradiance data during the first week of August 2019.	120
6.10	Example of the reference profile with which the baselining methods are benchmarked.	121
6.11	Curtailment profiles, before and after correction, for curtailment option 1.	123
6.12	Curtailment profiles, before and after correction, for curtailment option 2.	123
6.13	Comparing different baselining methods for curtailment option 1.	124
6.14	Comparing different baselining methods for curtailment option 2a.	125
6.15	Comparing different baselining methods for curtailment option 2b.	126
B.1	SGAM legend	140
B.2	SGAM component layer.	141
B.3	SGAM communication layer.	143
B.4	SGAM information layer.	144
B.5	SGAM function layer.	145
B.6	SGAM business layer.	146

List of Tables

- 5.1 Reflection on the price sensitivity of the customer outage minute assumption per PTU. For each assumed cost per customer outage minute, the effect on the price per MWh per % overloading is calculated. 86

- 6.1 Summary statistics of the solar irradiance, outdoor temperature and wind speed. The following labels are used: M for measurement data and F for the day-ahead forecast. 111
- 6.2 PV system parameters. 112
- 6.3 Error metric for baselines in the first weeks of May, June and July, 2019. Units in [W]. 128

- C.1 Overview of the different baseline analysis in literature. Categories according to section 6.2. 147

- D.1 Error metric for baselines in the middle weeks of May, June and July, 2019. Units in [W]. 152

List of Publications

Journal publications

R. Fonteijn, P.H. Nguyen, J. Morren, J.G. Slootweg. Baseline Flexibility from PV on the DSO-Aggregator Interface, *Applied Sciences, special issue on Local Electricity Markets: Current Trends, Mechanism Design and Participation*, 2021.

R. Fonteijn, P.H. Nguyen, J. Morren, J.G. Slootweg. Demonstrating a generic four-step approach for applying flexibility for congestion management in daily operation, *Sustainable Energy Grids and Networks*, 2020.

R. Fonteijn, M. van Amstel, P.H. Nguyen, J. Morren, G.M. Bonnema, J.G. Slootweg. Evaluating flexibility values for congestion management in distribution networks within Dutch pilots, *Journal of Engineering*, 2019.

Conference publications

H. Pourasghar Khomami, R. Fonteijn, D. Geelen, “Flexibility Market Design for Congestion Management in Smart Distribution Grids: the Dutch Demonstration of the Interflex Project”, *IEEE PES Innovative Smart Grid Technologies Conference Europe (ISGT-Europe)*, 2020

G. Rouwhorst, R. Fonteijn, A. Brouwer, P.H. Nguyen, J.G. Slootweg, “The Flexibility Potential to Reduce the Peak Load of Small and Medium-Sized Enterprises”, *Proceedings of the 2020 CIRED Workshop on How to Implement Flexibility in the Distribution System*, 2020

- S. Bhattacharyya, T. van Cuijk, R. Fonteijn, “Integrating smart storage and aggregators for network congestion management & voltage support in a pilot project in Eindhoven”, *the 25th International Conference and Exhibition on Electricity Distribution (CIRED)*, 2019
- R. Fonteijn, R. Bernardis, P.H. Nguyen, J. Morren, J.G. Slootweg, “Flexibility for congestion management: an operational decision-making process”, *the 25th International Conference and Exhibition on Electricity Distribution (CIRED)*, 2019
- R. Fonteijn, T. Castelijns, M. Grond, P.H. Nguyen, J. Morren, J.G. Slootweg, “Short-term load forecasting on MV/LV transformer level”, *the 25th International Conference and Exhibition on Electricity Distribution (CIRED)*, 2019
- R. Fonteijn, T. van Cuijk, P.H. Nguyen, J. Morren, J.G. Slootweg, “Flexibility for congestion management: A demonstration of a multi-mechanism approach”, *IEEE PES Innovative Smart Grid Technologies Conference Europe (ISGT-Europe)*, 2018
- P.W. Bierling, R. Fonteijn, P.H. Nguyen, “Review of multi-BRP aggregator settlement models at large-scale connections in the European electricity system”, *53rd International Power Engineering Conference (UPEC)*, 2018
- R. Fonteijn, M.H. Roos, P.H. Nguyen, J. Morren, J.G. Slootweg, “The Strijp-S living-lab: testing innovative solutions for fault protection, self-healing, congestion management, and voltage control”, *53rd International Universities Power Engineering Conference (UPEC)*, 2018
- R. Fonteijn, M.S. van Amstel, P.H. Nguyen, J. Morren, G.M. Bonnema, J.G. Slootweg, “Evaluating flexibility values for congestion management in distribution networks within Dutch pilots”, *the 7th International Conference on Renewable Power Generation (RPG)*, 2018
- M.H. Roos, R. Fonteijn, P.H. Nguyen, J. Morren, J.G. Slootweg, “The Strijp-S living lab for embedded microgrid studies”, *Proceedings of the 2018 CIRED Workshop on Microgrids and Local Energy Communities*, 2018
- R. Fonteijn, M. Babar, I.G. Kamphuis, “An assessment of the influence of demand response on demand elasticity in electricity retail market”, *50th International Universities Power Engineering Conference (UPEC)*, 2015

Other publications

R. Fonteijn, M.H. Roos, J.G. Slootweg, “Nieuwe mogelijkheden in het duurzame, decentrale elektriciteitssysteem”, *Nederlands Tijdschrift voor Natuurkunde*, pp. 20-25, August 2020

M. Zweistra, E. van Aalzum, J. Laarakkers, K. van Zwienen, M. Willems, D. Geelen, R. Steegh, P. Klapwijk, R. Fleskens, O. Westerlaken, R. Fonteijn, M. Postmus, “Lessons learned from use case #2 and #3.” InterFlex Deliverable D7.6, 2019.

T. van Cuijk, R. Fonteijn, D. Geelen, J. Laarakkers, P. Rademakers, B. Ran, O. Westerlaken, M. Willems, K. van Zuuren, K. van Zwienen, “Innovative solutions to be tested in the use cases.” InterFlex Deliverable D7.3, 2018.

R. Fonteijn, D. Geelen, P. Klapwijk, J. Laarakkers, P. Rademakers, B. Ran, O. Westerlaken, M. Willems, “UC planning, District architecture requirements and tested innovations”, InterFlex Deliverable D7.1/D7.2, 2018

R. Fonteijn, T. van Cuijk, J. Morren, J.G. Slootweg, “Nieuwe energietechnologieën mogelijk door flexibiliteitsmarkt”, *Energie+*, 37(4), pp. 8-10, 2017

Acknowledgements

Back in 2015, when I was working on my MSc thesis, I was considering to start a PhD. I discussed the possibility with (among others) Han Slootweg. At the time, there were no projects to which I could commit myself for four years. Little more than a year later, Han reached out to me and asked if I was still interested. By the beginning of 2017, it was clear a position was opening up related to the Dutch InterFlex sub-project. I got the position, starting a journey, during which (so it turned out) I did not only learn a lot about academia and the project, but also about myself on a personal level. Now, with the completion of my thesis, this journey is coming to an end.

A word of thanks to Han Slootweg, Phuong Nguyen and Johan Morren for your supervision, help, discussions and advice during this journey. You made it possible for me to get this far. You three made a great team to work with. Han, thanks for your clear and to-the-point feedback, making sure that what I was working on was relevant for, and could be understood by both academia and industry. Johan, thank you for the pragmatic solutions to problems I sometimes could not see a way around. Phuong, thank you for reminding me from time to time that it was a PhD I was working on, not an industry or engineering project. You made sure that I kept my academic contributions in mind. I would also like to thank my committee members for their valuable suggestions that helped improve the readability of this thesis.

Some might say a PhD journey is lonely. My colleagues of the EES group have, however, shown this is not necessarily the case. There was always someone able and willing to talk to or offer help. To all of you, named and unnamed, thanks for the great time. In particular a word of thanks to Annemarie, who has taken care of the necessary paperwork and practicalities. Then I would like to thank the colleagues with whom I shared the office: Andrew, Raoul, Arpit, Maikel, Tim, Sjoerd, George, and Roozbeh, thank you for the numerous morning coffee rounds, both physically on-campus and digitally due to

COVID-19 restrictions. It was great to be able to discuss anything and everything except our research, or to be able to rant a little (and sometimes a little more) about the issues ‘us PhDs’ run into. To my students: Paul, Dela, Steve, Lucas, George, Jakub, Sumona, and Lele, with whom I have had many, many discussions on (usually, but not exclusively) their thesis work. I wish you all the best in your future careers and personal lives.

When I decided to pursue a PhD, one of my wishes was the possibility to work in close collaboration with industry. I wanted to ensure the research I did was relevant and to be able to see the practical side of flexibility. I found this possibility with the Dutch InterFlex sub-project and at Enexis. Marcel and his team made me feel as a welcome and valued member of the project team. Not only have I been able to collaborate on the project, but through the project I have worked with Enexis’ data science team who provided the input for the forecasting algorithm and some related figures used in my research. A special word of thanks to Daphne, Ton, Dela, Raoul, Sharmistha, Marinus, Thomas, and Marieke, with whom I have collaborated on various publications. I am glad I can now officially call you my colleagues.

To my friends, I really appreciate the support and willingness to listen to me talk (and sometimes complain, we all know I am good at that) about my research. You also learned quickly which forbidden questions not to ask (for example: “How’s the thesis doing?”). Mijn familie, in het bijzonder Tom, pap en oma, bedankt voor jullie onvoorwaardelijke steun. Mam, ook al kan ik jou dit boekje niet meer overhandigen, heb ik je in mijn hart wel meegenomen op deze reis. Zonder jou had ik hier vandaag niet gestaan. Essi, rakas Essi, you were always there for me. Thank you for your patience, for putting things in perspective, for showing me what is really important, for giving me a hug when I needed one, and for putting a smile on my face (even on a bad day). I am not sure you always know what it is I am doing (when I was working on my thesis, I recall you asked me how my ‘science-fiction’ was going), but that is okay. Kiitos paljon, minun kultaseni.

Curriculum Vitae



Rik Fonteijn was born on December 13, 1988 in Weert, the Netherlands. After finishing his secondary education at sg. st. Ursula in Horn, he started his bachelor Electrical Engineering at Fontys University of Applied Sciences in Eindhoven. He did his graduation work in collaboration with the Dutch distribution system operator Liander and obtained his B.Eng. degree in 2011. Rik continued his studies at Eindhoven University of Technology, in the master program Sustainable Energy Technologies. He specialised in Electrical Energy Systems and after a graduation project with the Dutch transmission system operator TenneT, he obtained his M.Sc. degree

in 2015. After graduating, he was employed by Ecovat, where he worked on the flexible use of electricity markets for power-to-heat and thermal storage purposes. In 2017 he started his PhD research with the Electrical Energy Systems group at Eindhoven University of Technology, on a project in close collaboration with the Dutch distribution system operator Enexis. The results of this research are presented in this thesis. Since March 2021 he is employed at Enexis as a consultant.

