

A recursive estimation approach to distributed identification of large-scale multi-input-single-output FIR systems

Citation for published version (APA):

Steentjes, T. R. V., Lazar, M., & Van den Hof, P. M. J. (2018). A recursive estimation approach to distributed identification of large-scale multi-input-single-output FIR systems. *IFAC-PapersOnLine*, 51(23), 236-241. <https://doi.org/10.1016/j.ifacol.2018.12.041>

DOI:

[10.1016/j.ifacol.2018.12.041](https://doi.org/10.1016/j.ifacol.2018.12.041)

Document status and date:

Published: 01/01/2018

Document Version:

Accepted manuscript including changes made at the peer-review stage

Please check the document version of this publication:

- A submitted manuscript is the version of the article upon submission and before peer-review. There can be important differences between the submitted version and the official published version of record. People interested in the research are advised to contact the author for the final version of the publication, or visit the DOI to the publisher's website.
- The final author version and the galley proof are versions of the publication after peer review.
- The final published version features the final layout of the paper including the volume, issue and page numbers.

[Link to publication](#)

General rights

Copyright and moral rights for the publications made accessible in the public portal are retained by the authors and/or other copyright owners and it is a condition of accessing publications that users recognise and abide by the legal requirements associated with these rights.

- Users may download and print one copy of any publication from the public portal for the purpose of private study or research.
- You may not further distribute the material or use it for any profit-making activity or commercial gain
- You may freely distribute the URL identifying the publication in the public portal.

If the publication is distributed under the terms of Article 25fa of the Dutch Copyright Act, indicated by the "Taverne" license above, please follow below link for the End User Agreement:

www.tue.nl/taverne

Take down policy

If you believe that this document breaches copyright please contact us at:

openaccess@tue.nl

providing details and we will investigate your claim.

A recursive estimation approach to distributed identification of large-scale multi-input-single-output FIR systems^{*}

Tom R.V. Steentjes,^{*} Mircea Lazar,^{*}
Paul M.J. Van den Hof^{*}

^{*} *Department of Electrical Engineering, Eindhoven University of Technology, The Netherlands (e-mails: t.r.v.steentjes@tue.nl, m.lazar@tue.nl, p.m.j.vandenhof@tue.nl)*

Abstract: The problem of identifying single modules in multiple-input-single-output (MISO) systems is considered. A novel approach to distributed identification of MISO finite impulse response systems is presented. The distributed identification is discerned by the local estimation of local parameters, which correspond to a module in the MISO system. The local estimators are derived from the standard recursive least squares estimator and require limited information exchange. By Lyapunov's second method, sufficient conditions are derived for asymptotic convergence of the estimators to the true parameters in the absence of disturbances, which lead to asymptotic unbiasedness in the presence of additive output disturbances.

Keywords: Distributed estimation, recursive methods, identification, Lyapunov methods, convergence

1. INTRODUCTION

Prediction-error identification methods provide a powerful tool for obtaining consistent system parameter estimates (Ljung, 1999). However, when dealing with large scale interconnected systems, arising e.g. from biology or power grids, the identification problem becomes more challenging. Given a network of linear dynamical systems, various prediction error methods are readily operational for identifying these systems (Rao et al., 1984), (Van den Hof et al., 2013).

The identification problem of such large-scale systems can typically be separated into multiple-input-single-output (MISO) identification problems (Rao et al., 1984), (Van den Hof et al., 2013). More precisely, identification of a large-scale system can be performed via the identification of MISO building blocks, on the basis of measurements of multiple inputs and one, possibly disturbed, output. Figure 1 shows such a MISO building block.

Although existing prediction error methods for dynamical networks can consistently identify local modules (single-input-single-output (SISO) systems), they require the output signal and all input signals for a MISO identification problem to be available centrally for global parameter estimation. Central data collection and computation of the module estimates may not always be desirable due to computational constraints or desired flexibility. In (Rao et al., 1984), a decomposition of the MISO identification problem into SISO problems via a Gauss-Seidel like algorithm was suggested to reduce computational complexity, but a proof of convergence is absent.

^{*} Funded by the European Research Council (ERC), Advanced Research Grant SYSDYNET, under the European Unions Horizon 2020 research and innovation programme (grant agreement № 694504).

Distributed estimation has caught a vast amount of attention in the literature. Existing approaches can be divided into two distinct classes. The first class consists of consensus based methods, discerned by collaborative estimation of a global (common) parameter vector that is performed via a number of interconnected estimators (Mateos and Giannakis, 2012), (Papusha et al., 2014). The second class is also enabled by collaborative estimation via interconnected estimators. Therein each estimator is, however, concerned with the estimation of a local parameter vector. We refer to the results derived for parameter estimation in static large-scale systems (Marelli and Fu, 2015), distributed state estimation via moving-horizon methods (Farina et al., 2010) and distributed identification via ADMM (Hansson and Verhaegen, 2014).

In this work, we develop a distributed solution for the MISO prediction error identification problem (Van den Hof et al., 2013). Due to the simplifying property of yielding output predictors that are linear in the parameters, finite impulse response (FIR) model structures serve as a basis for the developed distributed identification method. The distributed identification scheme is composed of local recursive estimators that are coupled with local SISO modules. Intercommunication of the local estimators is accomplished through the transmission of scalar signals between recursions via a mutual fusion center.

2. PRELIMINARIES AND PROBLEM FORMULATION

The sets of non-negative integers and non-negative reals are denoted by \mathbb{N} and $\mathbb{R}_{\geq 0}$, respectively. Given $a \in \mathbb{N}$, $b \in \mathbb{N}$ such that $a < b$, we denote $\mathbb{N}_{[a:b]} := \{a, a+1, \dots, b-1, b\}$. Let $I_n \in \mathbb{R}^{n \times n}$ denote the identity

matrix. A function $\alpha : \mathbb{R}_{\geq 0} \rightarrow \mathbb{R}_{\geq 0}$ is said to belong to class \mathcal{K}_∞ ($\alpha \in \mathcal{K}_\infty$), if it is continuous, strictly increasing, $\alpha(0) = 0$ and $\alpha(r) \rightarrow \infty$ as $r \rightarrow \infty$. For an $x \in \mathbb{R}^n$, let $\|x\|_2$, or simply $\|x\|$, denote the 2-norm of x .

2.1 Concepts from Lyapunov theory

Consider the discrete-time, time-varying system

$$x(k+1) = f(x(k), k), \quad (1)$$

where $f : \mathbb{R}^n \times \mathbb{N} \rightarrow \mathbb{R}^n$, $f(0, \cdot) = 0$.

Theorem 2.1. The origin is a globally asymptotically stable equilibrium of (1) if there is a function $W : \mathbb{R}^n \times \mathbb{N} \rightarrow \mathbb{R}$ so that

$$k_1(\|\xi\|) \leq W(\xi, \tau) \leq k_2(\|\xi\|, \tau), \quad \forall (\xi, \tau) \in \mathbb{R}^n \times \mathbb{N}, \quad (2)$$

$$\Delta W(\xi, \tau) \leq -k_3(\|\xi\|), \quad \forall (\xi, \tau) \in \mathbb{R}^n \times \mathbb{N}, \quad (3)$$

where $\Delta W(\xi, \tau) := W(f(\xi, \tau), \tau+1) - W(\xi, \tau)$, $k_1 \in \mathcal{K}_\infty$, $k_2(\cdot, \tau) \in \mathcal{K}_\infty$ for each $\tau \in \mathbb{N}$ and $k_3 : \mathbb{R}_{\geq 0} \rightarrow \mathbb{R}_{\geq 0}$ a continuous and positive definite function.

If a uniform upperbound $k_2(\|\xi\|)$, $k_2 \in \mathcal{K}_\infty$, exists, uniform global asymptotic stability is obtained (Mendel, 1973, Theorem 4-3). We refer to (Steenjtes et al., 2018) for the proof of Theorem 2.1. The absence of a uniform upperbound on W avoids the need for a uniform upperbound on the gain or covariance matrix inverse, as in e.g. (Mendel, 1973), (Udink ten Cate, 1979), for proving convergence of the recursive estimation scheme in Section 4.

Definition 2.2. A function $W : \mathbb{R}^n \times \mathbb{N} \rightarrow \mathbb{R}$ that satisfies (2) and (3) is called a Lyapunov function for (1).

2.2 Prediction error set-up and least squares estimator

Consider a MISO system interconnection with m inputs and a measured output that is corrupted by a noise signal $v(t)$, described by

$$y(t) = \sum_{i=1}^m G_i(q)u_i(t) + v(t), \quad (4)$$

where $v(t) = H(q)e(t)$, with $e(t)$ zero-mean white noise with standard deviation σ for all $t \in \mathbb{N}$. System (4) can, for example, appear as a building block in dynamic networks analyzed in (Van den Hof et al., 2013), cf. (Van den Hof et al., 2013, Section 2.1). An example of such a MISO system with m inputs is shown in Figure 1.

A prediction error identification problem for identifying $G_i(q)$, $i \in \mathbb{N}_{[1:m]}$, is based on (Van den Hof et al., 2013): an output prediction

$$\hat{y}(t, \theta) := \hat{H}^{-1}(q, \theta) \left(\sum_{i=1}^m \hat{G}_i(q, \theta)u_i(t) \right) + (1 - \hat{H}^{-1}(q, \theta))y(t),$$

and the prediction error, defined by

$$\varepsilon(t, \theta) := y(t) - \hat{y}(t, \theta),$$

where $\hat{G}_i(q, \theta)$ is a model of transfer function $G_i(q)$, $i \in \mathbb{N}_{[1:m]}$, depending on a to-be-estimated parameter $\theta \in \mathbb{R}^n$.

Due to the possible independent parametrization and advantageous property of yielding an output prediction $\hat{y}(t, \theta)$ that is linear in the parameter θ , an FIR model structure will be employed in the sequel. Utilizing an FIR

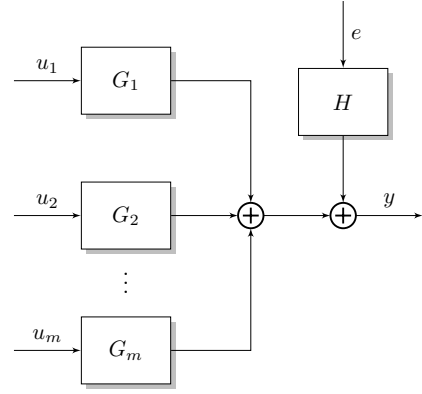

Fig. 1. MISO system interconnection with $m \in \mathbb{N}$ subsystems.

model structure, the noise model $\hat{H}(q, \theta) = 1$ is fixed and the plant models are

$$\hat{G}_i(q, \theta) = B_i(q, \theta) \quad (5)$$

for all $i \in \mathbb{N}_{[1:m]}$, where

$$B_i(q, \theta) := b_0^i + b_1^i q^{-1} + \dots + b_{n_i-1}^i q^{-n_i+1},$$

with $n_i \in \mathbb{N}$ the number of parameters in the polynomial $B_i(q, \theta)$, $i \in \mathbb{N}_{[1:m]}$. Consequently, the output prediction is

$$\hat{y}(t, \theta) = \sum_{i=1}^m B_i(q, \theta)u_i(t) = \sum_{i=1}^m \varphi_i^\top(t)\theta_i, \quad (6)$$

with $\theta_i := \text{col}(b_0^i, \dots, b_{n_i-1}^i)$ and

$$\varphi_i^\top(t) := (u_i(t) \dots u_i(t - n_i + 1)),$$

such that the total parameter vector is $\theta := \text{col}(\theta_1, \dots, \theta_m)$ and $\varphi(t) := \text{col}(\varphi_1(t), \dots, \varphi_m(t))$.

Given $N \in \mathbb{N}$ available data samples of y and φ_i , $i \in \mathbb{N}_{[1:m]}$, let the identification criterion be $\min_\theta J_{\text{LS}}(\theta)$, where $J_{\text{LS}} : \mathbb{R}^n \rightarrow \mathbb{R}$ is defined by

$$J_{\text{LS}}(\theta) := \frac{1}{N} \sum_{t=0}^{N-1} \varepsilon^2(t, \theta) = \frac{1}{N} \|\mathbf{y} - \Phi\theta\|_2^2,$$

with vector $\mathbf{y}^\top := (y(0), \dots, y(N-1))$ and matrix $\Phi^\top := (\varphi(0), \dots, \varphi(N-1))$. The optimal parameter estimate is explicitly known to be (Kay, 1993)

$$\hat{\theta} := \arg \min_\theta J_{\text{LS}}(\theta) = (\Phi^\top \Phi)^{-1} \Phi^\top \mathbf{y}. \quad (7)$$

The parameter estimate $\hat{\theta}$ is referred to as the *least squares estimator* (LSE). The covariance matrix of the LSE is $\Sigma = \sigma^2 (\Phi^\top \Phi)^{-1}$ (Kay, 1993).

2.3 Recursive least squares

In practice, computing the LSE can be undesirable when all the data \mathbf{y} and Φ are not available at once or when (7) is computationally intractable, for example. Instead, one can use a recursive LSE (Kay, 1993), which updates the LSE each time new data is available.

Let $\hat{\theta}(k)$ denote the LSE of θ based on $k+1$ data samples $\mathbf{y}(k) = (y(0) \dots y(k))^\top$ and $\Phi(k) = (\varphi(0) \dots \varphi(k))^\top$. The recursive LSE reads as follows (Kay, 1993). First, compute the “batch” estimator $\hat{\theta}(k)$ for $k \in \mathbb{N}$:

$$\hat{\theta}(k) = (\Phi(k)^\top \Phi(k))^{-1} \Phi(k)^\top \mathbf{y}(k), \quad (8)$$

$$\Sigma(k) = \sigma^2 (\Phi(k)^\top \Phi(k))^{-1}.$$

When new data is available, update the estimator according to

$$\begin{aligned}\hat{\theta}(k+1) &= \hat{\theta}(k) \\ &+ \alpha(k)\Sigma(k)\varphi(k+1)(y(k+1) - \varphi^\top(k+1)\hat{\theta}(k)), \\ \alpha(k) &:= \frac{1}{\sigma^2 + \varphi^\top(k+1)\Sigma(k)\varphi(k+1)}.\end{aligned}$$

The covariance matrix of the updated LSE is

$$\Sigma(k+1) = (I - \alpha(k)\Sigma(k)\varphi(k+1)\varphi^\top(k+1))\Sigma(k). \quad (9)$$

Remark 2.3. The recursive LSE and covariance matrix can be written in a more compact form, using the prediction error definition and the matrix inversion lemma, as

$$\hat{\theta}(k+1) = \hat{\theta}(k) + \alpha(k)\Sigma(k)\varphi(k+1)\varepsilon(k+1, \hat{\theta}(k)), \quad (10)$$

$$\Sigma^{-1}(k+1) = \Sigma^{-1}(k) + \frac{1}{\sigma^2}\varphi(k+1)\varphi^\top(k+1), \quad (11)$$

respectively.

Remark 2.4. One can avoid the computation of a batch LSE (8) completely, by initialization of the recursive LSE (10) from “scratch” with $\hat{\theta}(-1) = 0$ and $\Sigma(-1) = cI$, with $c \in \mathbb{R}_{\geq 0}$ (Kay, 1993).

2.4 Problem formulation

Given the prediction error identification problem for the MISO system described in Section 2.2, central collection of m input signals u_i and one output signal y is required¹ for the central computation of $\hat{\theta}$, using either the LSE (7) or the recursive LSE (10). From a distributed point of view, however, local module parameter estimators $\hat{\theta}_i$ for θ_i may be preferred, due to computational or communication constraints. We will refer to the concept of distributed identification, as the local parameter estimation for G_i via a local identification module, with intercommunication between local identification modules. The distributed identification concept is illustrated in Figure 2: Each subsystem G_i , $i \in \mathbb{N}_{[1:m]}$ is coupled with an identification module \mathcal{I}_i , which measures input u_i and is connected to some module \mathcal{B} , which measures the (shared) output y . Module \mathcal{B} describes the relation between sent and received signals of all modules \mathcal{I}_i . Given this distribution, two problems arise, related to the local identification and communication. Firstly, is there an \mathcal{I}_i that arrives at unbiased estimates of the true parameter θ_i^0 ? Consequently, if the answer is affirmative, what signals have to be shared between the identification modules \mathcal{I}_i , $i \in \mathbb{N}_{[1:m]}$, i.e., what should \mathcal{B} describe?

Since the data matrix Φ is in general non-sparse, the identification problem $\min_{\theta} J_{LS}(\theta)$ is in general non-separable. Therefore, it is not clear how the LSE (7) can be adopted in a distributed identification scheme. The recursive LSE, however, can be advantageous for the distribution of the parameter estimation. Indeed, one can exploit structures for the parameter covariance matrix $\Sigma(k)$, such as diagonal or block-diagonal structures, in order to “separate” the estimation problem w.r.t. θ_i , $i \in \mathbb{N}_{[1:m]}$. Finally, asymptotic unbiasedness of the developed distributed identification procedure should be assessed, i.e., we need to verify whether $\lim_{k \rightarrow \infty} \mathbb{E} \hat{\theta}_i(k) \rightarrow \theta_i^0$, where $\hat{\theta}_i(k)$ denotes the proposed estimator for θ_i^0 based on $k+1$ data samples.

¹ We remark that if all u_i 's are uncorrelated, then SISO identification (without modelling other subsystems) provides consistent estimates. This will lead to increased variance, however.

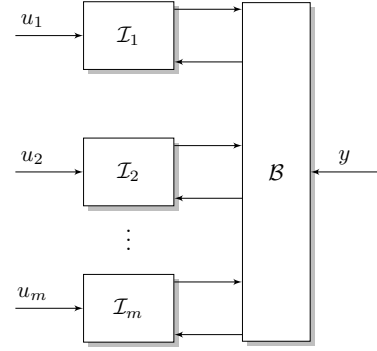

Fig. 2. Distributed identification scheme with identification modules \mathcal{I}_i , $i \in \mathbb{N}_{[1:m]}$ and communication module \mathcal{B} .

3. DISTRIBUTED ESTIMATION ALGORITHM

Inspired by the recursive LSE (10), we develop a distributed recursive estimator: for each $i \in \mathbb{N}_{[1:m]}$, let the local parameter estimator $\hat{\theta}_i : \mathbb{N} \rightarrow \mathbb{R}^{n_i}$ be defined recursively by

$$\begin{aligned}\hat{\theta}_i(k+1) &= \hat{\theta}_i(k) \\ &+ \alpha_i(k)\Sigma_i(k)\varphi_i(k+1)(y(k+1) - \sum_{j=1}^m \varphi_j(k+1)\hat{\theta}_j(k)),\end{aligned} \quad (12)$$

with $\alpha_i : \mathbb{N} \rightarrow \mathbb{R}$ and $\Sigma_i : \mathbb{N} \rightarrow \mathbb{R}^{n_i \times n_i}$. Comparing the local estimator update equation (12) with the recursive LSE (10), the matrix Σ_i has the interpretation of a local covariance matrix of $\hat{\theta}_i$. Let $\Sigma_i : \mathbb{N} \rightarrow \mathbb{R}^{n_i \times n_i}$ be defined recursively by

$$\Sigma_i^{-1}(k+1) = \Sigma_i^{-1}(k) + \frac{1}{\gamma_i^2(k)}\varphi_i(k+1)\varphi_i^\top(k+1), \quad (13)$$

with $\gamma_i : \mathbb{N} \rightarrow \mathbb{R}$. The scalars $\alpha_i(k)$ and $\gamma_i(k)$ are related to sufficient conditions for consistency of estimator (12), which will be provided in Section 4.

Consider the stacked vector $\hat{\theta}_B(k) := \text{col}(\hat{\theta}_1(k), \dots, \hat{\theta}_m(k))$. Let $A_B(k) := \text{diag}(\alpha_1(k)I_{n_1}, \dots, \alpha_m(k)I_{n_m})$ and let $\Gamma_B(k) := \text{diag}(\gamma_1(k)I_{n_1}, \dots, \gamma_m(k)I_{n_m})$. Define accordingly

$$\begin{aligned}\Sigma_B(k) &:= \text{diag}(\Sigma_1(k), \dots, \Sigma_m(k)), \\ \varphi_B(k) &:= \text{diag}(\varphi_1(k)\varphi_1^\top(k), \dots, \varphi_m(k)\varphi_m^\top(k)).\end{aligned}$$

For the estimator update we can then write

$$\hat{\theta}_B(k+1) = \hat{\theta}_B(k) + A_B(k)\Sigma_B(k)\varphi(k+1)\varepsilon(k+1, \hat{\theta}_B(k))$$

with

$$\Sigma_B^{-1}(k+1) = \Sigma_B^{-1}(k) + \Gamma_B^{-2}(k)\varphi_B(k+1).$$

The latter equations seem to resemble (10) and (11), which describe the recursive LSE. Note, however, that the matrix Σ_B is block diagonal, while the covariance matrix Σ is dense, in general.

Now, let identification module \mathcal{I}_i be described by (12) and (13) so that

$$\mathcal{I}_i: \begin{cases} \hat{\theta}_i(k+1) = \hat{\theta}_i(k) + \alpha_i(k)\Sigma_i(k)\varphi_i(k+1)\varepsilon(k+1, \hat{\theta}_B(k)) \\ \Sigma_i^{-1}(k+1) = \Sigma_i^{-1}(k) + \frac{1}{\gamma_i^2(k)}\varphi_i(k+1)\varphi_i^\top(k+1). \end{cases}$$

Writing the distributed estimator (12) as

$$\begin{aligned} \hat{\theta}_i(k+1) &= \hat{\theta}_i(k) + \alpha_i(k)\Sigma_i(k)\varphi_i(k+1) \\ &\cdot (y(k+1) - \varphi_i^\top(k+1)\hat{\theta}_i(k) - \sum_{j \in \mathbb{N}_{[1:m]} \setminus \{i\}} \varphi_j^\top(k+1)\hat{\theta}_j(k)), \end{aligned}$$

it becomes apparent what information exchange is required between identification modules, assuming that each module \mathcal{I}_i can measure input $u_i(t)$ and receive output $y(t)$. The local recursive estimator $\hat{\theta}_i(k+1)$, $i \in \mathbb{N}_{[1:m]}$, depends on an ‘‘autonomous’’ part plus a contribution from other identification modules \mathcal{I}_j , $j \in \mathbb{N}_{[1:m]} \setminus \{i\}$. The inputs from other subsystems and parameter vectors $\hat{\theta}_j$ are not required to be known. Indeed, only the scalar products $\varphi_j^\top(k+1)\hat{\theta}_j(k) \in \mathbb{R}$ need to be known, for all $j \in \mathbb{N}_{[1:m]} \setminus \{i\}$, which we will refer to as the local predictions. The appropriate communication can be achieved if, for example, at every time step, each \mathcal{I}_i sends the local prediction $\varphi_i^\top(k+1)\hat{\theta}_i(k) \in \mathbb{R}$ to all other identification modules \mathcal{I}_j , $j \in \mathbb{N}_{[1:m]} \setminus \{i\}$ with a corresponding definition for \mathcal{B} . The latter corresponds to an all-to-all communication, however, and can be inefficient for large m . One can instead consider \mathcal{B} to be described by the static relation

$$\mathcal{B}: \quad \varepsilon(k+1, \hat{\theta}_B(k)) = y(k+1) - \sum_{i=1}^m \varphi_i^\top(k+1)\hat{\theta}_i(k)$$

and consider the following distributed identification procedure to improve efficiency in the communication:

For all $i \in \mathbb{N}_{[1:m]}$, initialize \mathcal{I}_i at $k=0$ with $\hat{\theta}_i(0) \in \mathbb{R}^{n_i}$ and $0 \prec \Sigma_i(0) \in \mathbb{R}^{n_i \times n_i}$. For each time $k \in \mathbb{N}$ perform

- (i) For each $i \in \mathbb{N}_{[1:m]}$, \mathcal{I}_i measures $u_i(k+1)$ and sends the local prediction $\varphi_i^\top(k+1)\hat{\theta}_i(k) \in \mathbb{R}$ to \mathcal{B} .
- (ii) \mathcal{B} measures $y(k+1)$ and returns the prediction error $\varepsilon(k+1, \hat{\theta}_B(k))$ to \mathcal{I}_i , $i \in \mathbb{N}_{[1:m]}$.
- (iii) For each $i \in \mathbb{N}_{[1:m]}$, \mathcal{I}_i computes $\hat{\theta}_i(k+1)$ and $\Sigma_i(k+1)$ by (12) and (13), respectively.

Remark 3.1. The distributed identification procedure can be viewed as a central fusion, distributed computation scheme: local estimations are obtained by modules \mathcal{I}_i , $i \in \mathbb{N}_{[1:m]}$, which all connect to \mathcal{B} . This scheme reflects the interconnection of the MISO system in Figure 1, where all G_i , $i \in \mathbb{N}_{[1:m]}$, connect to a single summation point.

4. CONVERGENCE ANALYSIS

Now that the central and distributed estimators are updated according to (10) and (12), respectively, let us analyze the asymptotic properties of the estimators. In this section, we will first assume perfect measurements of the system output $y(t)$, i.e., the noise signal $v(t) = 0$ for $t \in \mathbb{N}$, and that system (4) is in the FIR model set, i.e., the output of the real system $y(t)$ can be described by $y(t) = \varphi^\top(t)\theta^0$. We will analyze the desired convergence $\hat{\theta} \rightarrow \theta^0$ via Lyapunov’s second method, as was done in the analysis of gradient algorithms for deterministic parameter estimation in (Udink ten Cate, 1979) and (Mendel, 1973).

4.1 Central recursive LSE

We will briefly pay attention to a convergence result for the recursive LSE, to show the analogy with the convergence

result for the distributed recursive estimator in Section 4.2.

Consider the estimator error $\tilde{\theta}(k) := \hat{\theta}(k) - \theta^0 \in \mathbb{R}^n$. In the absence of noise ($v(t) = 0$), it follows from (10) that the recursive LSE error dynamics are described by

$$\tilde{\theta}(k+1) = \tilde{\theta}(k) - \alpha(k)\Sigma(k)\varphi(k+1)\varphi^\top(k+1)\tilde{\theta}(k), \quad (14)$$

$$\Sigma^{-1}(k+1) = \Sigma^{-1}(k) + \frac{1}{\sigma^2}\varphi(k+1)\varphi^\top(k+1). \quad (15)$$

Observe that the origin is clearly an equilibrium of difference equation (14).

Convergence The following result demonstrates that the estimation error converges to zero for the recursive LSE in the deterministic case, i.e., when the noise $v(t) = 0$ for all $t \in \mathbb{N}$. A similar result was proven in (Udink ten Cate, 1979), for a least-squares like gradient algorithm.

Proposition 4.1. Let $W_C : \mathbb{R}^n \times \mathbb{N} \rightarrow \mathbb{R}$ be defined by

$$W_C(\xi, \tau) := \xi^\top \Sigma^{-1}(\tau)\xi$$

and let $\Sigma(k)$ satisfy (15), $\Sigma(0) \succ 0$. Assume that $\tilde{\theta}(k)$ and $\varphi(k+1)$ are not orthogonal for all $k \in \mathbb{N}$. Then $W_C : \mathbb{R}^n \times \mathbb{N} \rightarrow \mathbb{R}$ is a Lyapunov function for (14).

Remark 4.2. When $\tilde{\theta}(k)$ and $\varphi(k+1)$ are orthogonal, the error system (14) is stable, but not guaranteed to be asymptotically stable, and convergence cannot be concluded. Orthogonality can, however, always be avoided by utilizing input signals with sufficient independent frequencies (Mendel, 1973).

4.2 Distributed recursive estimator

Estimator error dynamics Consider the distributed recursive estimator (12). When no noise is present in the measured output $y(t)$ ($v(t) = 0$), the distributed estimator update (12) can be written as

$$\begin{aligned} \hat{\theta}_i(k+1) &= \hat{\theta}_i(k) + \alpha_i(k)\Sigma_i(k)\varphi_i(k+1) \\ &\cdot \left(\sum_{j=1}^m \varphi_j^\top(k+1)\theta_j^0 - \sum_{j=1}^m \varphi_j^\top(k+1)\hat{\theta}_j(k) \right) \end{aligned}$$

where we used $y(k) = \sum_{j=1}^m \varphi_j^\top(k)\theta_j^0$. Now, define the error vector $\tilde{\theta}_B(k) := \hat{\theta}_B(k) - \theta^0 \in \mathbb{R}^n$. We then have

$$\begin{aligned} \tilde{\theta}_B(k+1) &= \hat{\theta}_B(k+1) - \theta^0 \\ &= \hat{\theta}_B(k) - \theta^0 + A_B(k)\Sigma_B(k)\varphi(k+1) \\ &\quad \cdot \sum_{j=1}^m \varphi_j^\top(k+1)(\theta_j - \hat{\theta}_j(k)) \\ &= \tilde{\theta}_B(k) - A_B(k)\Sigma_B(k)\varphi(k+1)\varphi^\top(k+1)\tilde{\theta}_B(k) \\ &= F(k)\tilde{\theta}_B(k) \end{aligned}$$

with $F(k) := I_n - A_B(k)\Sigma_B(k)\varphi(k+1)\varphi^\top(k+1)$.

Recalling the difference equation for the gain matrix $\Sigma_B(k)$, we conclude that the error behavior of the distributed recursive estimator (12) is described by

$$\tilde{\theta}_B(k+1) = F(k)\tilde{\theta}_B(k), \quad (16)$$

$$\Sigma_B^{-1}(k+1) = \Sigma_B^{-1}(k) + \Gamma_B^{-2}(k)\varphi_B(k+1), \quad (17)$$

where $\Gamma_B^{-2}(k) = \text{diag}(\gamma_1^{-2}(k)I_{n_1}, \dots, \gamma_m^{-2}(k)I_{n_m})$.

Convergence The following result proves the existence of the scalar functions $\gamma_i(k)$ for each estimator, such that the distributed estimation error vector converges to zero in the deterministic case.

Theorem 4.3. Let $W_B : \mathbb{R}^n \times \mathbb{N} \rightarrow \mathbb{R}$ be defined by

$$W_B(\xi, \tau) := \xi^\top \Sigma_B^{-1}(\tau) \xi$$

and let $\Sigma_B(\cdot)$ satisfy (17), $\Sigma_B(0) \succ 0$. For all $i \in \mathbb{N}_{[1:m]}$, let $\alpha_i = \alpha_B$, with $\alpha_B(k) := (\sigma^2 + \sum_{j=1}^m \varphi_j^\top(k+1) \Sigma_j(k) \varphi_j(k+1))^{-1}$. Assume that $\tilde{\theta}_B(k)$ and $\varphi(k+1)$ are not orthogonal for all $k \in \mathbb{N}$. Then there exist $\gamma_i, i \in \mathbb{N}_{[1:m]}$, such that $W_B : \mathbb{R}^n \times \mathbb{N} \rightarrow \mathbb{R}$ is a Lyapunov function for (16).

Proof. We will first prove that there exists $k_1 \in \mathcal{K}_\infty$ s.t. $W_B(\xi, \tau) \geq k_1(\|\xi\|)$ for all $(\xi, \tau) \in \mathbb{R}^n \times \mathbb{N}$, by induction. Let $\xi \in \mathbb{R}^n$ be arbitrary and let $k_1(r) := \lambda_{\min}(\Sigma_B^{-1}(0))r^2$. We claim that $W_B(\xi, \tau) \geq k_1(\|\xi\|)$ for all $\tau \in \mathbb{N}$. For the base case $\tau = 0$ the statement is true, since we have $W_B(\xi, 0) \geq \lambda_{\min}(\Sigma_B^{-1}(0))\|\xi\|^2 = k_1(\|\xi\|)$. Now, let $W_B(\xi, k) \geq k_1(\|\xi\|)$ be true for some $k \in \mathbb{N}$. Then

$$\begin{aligned} W_B(\xi, k+1) &= \xi^\top \Sigma_B^{-1}(k+1) \xi \\ &= \xi^\top \Sigma_B^{-1}(k) \xi + \underbrace{\xi^\top \Gamma_B^{-2}(k) \varphi_B(k+1)}_{\geq 0} \xi \\ &\geq \xi^\top \Sigma_B^{-1}(k) \xi \geq k_1(\|\xi\|), \end{aligned}$$

thus the statement is also true for $k+1$. We conclude that $W_B(\xi, \tau) \geq k_1(\|\xi\|)$ for all $(\xi, \tau) \in \mathbb{R}^n \times \mathbb{N}$. For the upperbound, let $k_2(r, k) := \lambda_{\max}(\Sigma_B^{-1}(k))r^2$. Then $W_B(\xi, \tau) \leq \lambda_{\max}(\Sigma_B^{-1}(\tau))\|\xi\|^2 = k_2(\|\xi\|, \tau)$ for all $\xi \in \mathbb{R}^n$.

Let us now analyze the one-step-difference $\Delta W_B(k) := W_B(\tilde{\theta}_B(k+1), k+1) - W_B(\tilde{\theta}_B(k), k)$. Using the distributed estimator error dynamics (16), we find

$$\begin{aligned} \Delta W_B(k) &= \tilde{\theta}_B^\top(k+1) \Sigma_B^{-1}(k+1) \tilde{\theta}_B(k+1) \\ &\quad - \tilde{\theta}_B^\top(k) \Sigma_B^{-1}(k) \tilde{\theta}_B(k) \\ &= \tilde{\theta}_B^\top(k+1) (\Sigma_B^{-1}(k+1) - \Sigma_B^{-1}(k)) \tilde{\theta}_B(k+1) \\ &\quad + \tilde{\theta}_B^\top(k+1) \Sigma_B^{-1}(k) \tilde{\theta}_B(k+1) - \tilde{\theta}_B^\top(k) \Sigma_B^{-1}(k) \tilde{\theta}_B(k) \\ &= \overline{\Delta W}_B(k) \\ &\quad + \tilde{\theta}_B^\top(k+1) (\Sigma_B^{-1}(k+1) - \Sigma_B^{-1}(k)) \tilde{\theta}_B(k+1), \end{aligned}$$

where

$$\begin{aligned} \overline{\Delta W}_B &:= \tilde{\theta}_B^\top(k+1) \Sigma_B^{-1}(k) \tilde{\theta}_B(k+1) - \tilde{\theta}_B^\top(k) \Sigma_B^{-1}(k) \tilde{\theta}_B(k) \\ &= \tilde{\theta}_B^\top \Sigma_B^{-1} \tilde{\theta}_B - 2\tilde{\theta}_B^\top \varphi^\top \Sigma_B A_B \Sigma_B^{-1} \tilde{\theta}_B \\ &\quad + \tilde{\theta}_B^\top \varphi \varphi^\top \Sigma_B A_B \Sigma_B^{-1} A_B \Sigma_B \varphi \varphi^\top \tilde{\theta}_B \\ &\quad - \tilde{\theta}_B^\top \Sigma_B^{-1} \tilde{\theta}_B \\ &= \tilde{\theta}_B^\top \varphi \varphi^\top \Sigma_B A_B \Sigma_B^{-1} A_B \Sigma_B \varphi \varphi^\top \tilde{\theta}_B \\ &\quad - 2\tilde{\theta}_B^\top \varphi \varphi^\top \Sigma_B A_B \Sigma_B^{-1} \tilde{\theta}_B. \end{aligned}$$

Now, since $\alpha_i = \alpha_B$ for all $i \in \mathbb{N}_{[1:m]}$, we have that $\overline{\Delta W}_B$ simplifies to

$$\begin{aligned} \overline{\Delta W}_B &= \alpha_B^2 \tilde{\theta}_B^\top \varphi \varphi^\top \Sigma_B \varphi \varphi^\top \tilde{\theta}_B - 2\alpha_B \tilde{\theta}_B^\top \varphi \varphi^\top \tilde{\theta}_B \\ &= -\alpha_B (\tilde{\theta}_B^\top \varphi)^2 (2 - \alpha_B \varphi^\top \Sigma_B \varphi), \end{aligned}$$

so that $\overline{\Delta W}_B$ is negative when

$$0 < \alpha_B < \frac{2}{\varphi^\top \Sigma_B \varphi}.$$

Since $\alpha_B = (\sigma^2 + \sum_{j=1}^m \varphi_j^\top \Sigma_j \varphi_j)^{-1}$, the latter condition is satisfied, such that $\overline{\Delta W}_B < 0$.

By equation (17), the one-step-difference is equal to

$$\begin{aligned} \Delta W_B(k) &= \overline{\Delta W}_B + \tilde{\theta}_B^\top(k+1) \Gamma_B^{-2}(k) \varphi_B(k+1) \tilde{\theta}_B(k+1) \\ &= \overline{\Delta W}_B + \sum_{i=1}^m \frac{1}{\gamma_i^2(k)} \tilde{\theta}_i^\top(k+1) \varphi_i \varphi_i^\top \tilde{\theta}_i(k+1) \\ &\leq \overline{\Delta W}_B + \sum_{i=1}^m \frac{1}{\gamma_i^2(k)} \sum_{j=1}^m (\tilde{\theta}_j^\top(k+1) \varphi_j)^2, \end{aligned}$$

where we used the Cauchy-Schwarz inequality. The decrease condition $\Delta W_B(k) < 0$ is therefore satisfied whenever $\gamma_i(k), i \in \mathbb{N}_{[1:m]}$, are so large that

$$\sum_{i=1}^m \frac{1}{\gamma_i^2(k)} < \frac{|\overline{\Delta W}_B|}{\tilde{\theta}_B^\top(k) F^\top(k) \varphi_B F(k) \tilde{\theta}_B(k)}$$

for all $k \in \mathbb{N}$, which is equivalent to the existence of $k_3 : \mathbb{R}_{\geq 0} \rightarrow \mathbb{R}_{\geq 0}$ such that (3) holds (Malisoff and Mazenc, 2009). This concludes the proof. \square

Remark 4.4. The difference in the stability analysis of the distributed estimator w.r.t. the recursive LSE is induced by (17). The block-diagonality of φ_B requires conditions on γ_i for stability, whereas a multiplication of $\varphi \varphi^\top$ with σ^{-2} in (15) suffices for stability of the recursive LSE.

Remark 4.5. The proof of Theorem 4.3 gives exact conditions on the scalar functions $\gamma_i(k)$. When $\gamma_i(k) = \gamma_i$ is chosen to be a constant, it suffices to assume that $\gamma_i \in \mathbb{R}$ is large enough, such that $\Delta W_B(k) < 0$.

In the presence of noise, the error dynamics for the distributed estimator are described by

$$\tilde{\theta}_B(k+1) = F(k) \tilde{\theta}_B(k) + G(k) v(k+1),$$

with $G(k) := A_B(k) \Sigma_B(k) \varphi(k+1)$. The following result provides sufficient conditions for asymptotic unbiasedness of the distributed estimator $\hat{\theta}_B$.

Proposition 4.6. Let $\prod_{\tau=t+1}^k F(\tau) G(t)$ and $v(t)$ be statistically independent for all $t \in \mathbb{N}$. If there exists a Lyapunov function for (16), then $\lim_{k \rightarrow \infty} \mathbb{E} \theta_B(k) = \theta^0$.

Proof. We refer the reader to the proof of (Mendel, 1973, Theorem 2-5).

5. NUMERICAL EXAMPLE

Consider the data generating system (4) with $m = 20$ subsystems, so that $y(t) = \sum_{i=1}^{20} B_i(q) u_i(t) + v(t)$, with $B_i(q) = b_0^i + b_1^i q^{-1} + \dots + b_{n_i-1}^i q^{-n_i+1}$ and $v(t)$ zero-mean white Gaussian noise with standard deviation $\sigma = 0.1$. For this illustrative example, the subsystems $G_i(q)$ of the data generating system are constructed in a random fashion as follows: each subsystem has $n_i \in \mathbb{N}$ unknown parameters, which is an integer drawn from a discrete uniform distribution $\mathcal{U}\{1, 10\}$ using the MATLAB function `randi`, i.e., subsystem G_i has $n_i \in \mathbb{N}_{[1:10]}$ unknown parameters. The constant parameters $b_j^i \in \mathbb{R}, j \in \mathbb{N}_{[0:n_i-1]}, i \in \mathbb{N}_{[1:20]}$, are drawn from a normal distribution $\mathcal{N}(0, 1)$ in MATLAB using `randn`. The total number of to-be-estimated parameters is $n = \sum_{i=1}^{20} n_i = 102$.

We apply the distributed recursive estimation procedure from Section 3. The local estimators $\hat{\theta}_i : \mathbb{N} \rightarrow \mathbb{R}^{n_i}$ are described by (12) with $\alpha_i = \alpha_B, i \in \mathbb{N}_{[1:20]}$, as defined in Theorem 4.3. The matrices $\Sigma_i : \mathbb{N} \rightarrow \mathbb{R}^{n_i \times n_i}$ are

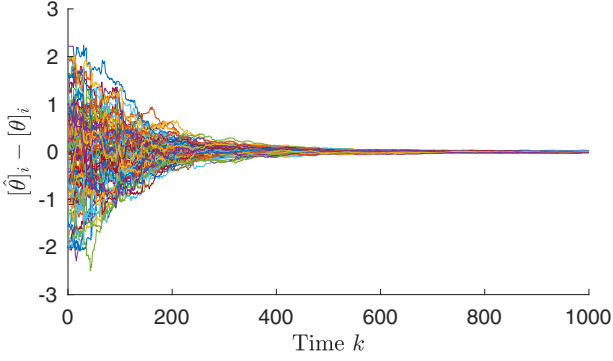

Fig. 3. Evolution of the estimation error for all parameters $[\hat{\theta}]_j - [\theta^0]_j$, $j \in \mathbb{N}_{[1:102]}$, for the central identification of a MISO system with $m = 20$ subsystems.

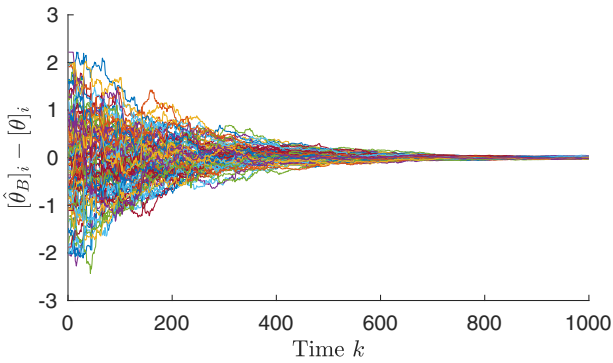

Fig. 4. Evolution of the estimation error for all parameters $[\hat{\theta}_B]_j - [\theta^0]_j$, $j \in \mathbb{N}_{[1:102]}$, for the distributed identification of a MISO system with $m = 20$ subsystems.

described by (13), with $\gamma_i(k) = \gamma = 100$. For comparison, we apply a corresponding central recursive estimator, i.e., the recursive LSE (10) with the update for the matrix $\Sigma : \mathbb{N} \rightarrow \mathbb{R}^{n \times n}$ described by $\Sigma^{-1}(k+1) = \Sigma^{-1}(k) + \gamma^{-2} \varphi(k+1) \varphi^T(k+1)$ instead of (11).

Figure 3 and 4 show the evolution of the estimation error over time for the central and distributed estimator, respectively, initialized in $\hat{\theta}(1) = \hat{\theta}_B(1) = 0$ and $\Sigma(1) = \Sigma_B(1) = 100I_{102}$. The overall estimation errors $\|\hat{\theta}(k) - \theta^0\|^2$ and $\|\hat{\theta}_B(k) - \theta^0\|^2$ are shown in Figure 5 in blue and red, respectively. We observe a lower decrease rate for the estimation errors in the distributed identification scheme w.r.t. the central scheme, in general, while convergence is observed for both schemes.

6. CONCLUSIONS

We have stated a recursive estimation algorithm for the distributed identification of MISO FIR systems, derived from a central recursive least squares estimator. The distributed identification scheme consists of local identification modules, which estimate a subvector of the total parameter vector. Via Lyapunov's second method, we have obtained sufficient conditions for asymptotic convergence of the estimators to the true parameters in the absence of noise, which leads to asymptotic unbiasedness in the presence of a white noise signal at the system's output.

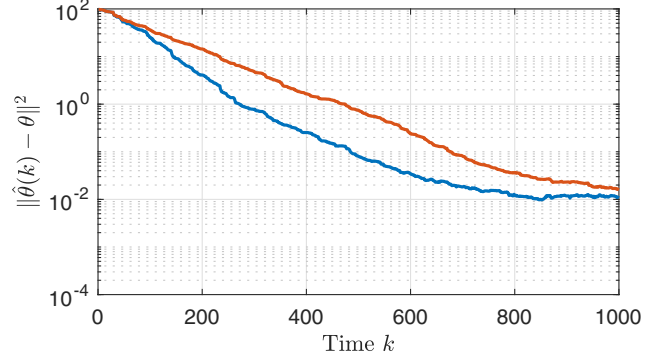

Fig. 5. Estimation error for the central estimator $\|\hat{\theta}(k)\|^2$ (blue) and distributed estimator $\|\hat{\theta}_B(k)\|^2$ (red) for $\gamma = 100$.

REFERENCES

- Farina, M., Ferrari-Trecate, G., and Scattolini, R. (2010). Moving-horizon partition-based state estimation of large-scale systems. *Automatica*, 46(5), 910 – 918.
- Hansson, A. and Verhaegen, M. (2014). Distributed system identification with ADMM. In *53rd IEEE Conference on Decision and Control*, 290–295.
- Kay, S.M. (1993). *Fundamentals of Statistical Signal Processing: Estimation Theory*. Prentice-Hall, Inc., Upper Saddle River, NJ, USA.
- Ljung, L. (1999). *System Identification: Theory for the User*. Prentice Hall PTR, Upper Saddle River, NJ, USA.
- Malisoff, M. and Mazenc, F. (2009). *Constructions of Strict Lyapunov Functions*. Springer-Verlag London.
- Marelli, D.E. and Fu, M. (2015). Distributed weighted least-squares estimation with fast convergence for large-scale systems. *Automatica*, 51, 27 – 39.
- Mateos, G. and Giannakis, G.B. (2012). Distributed recursive least-squares: Stability and performance analysis. *IEEE Trans. Signal Process.*, 60(7), 3740–3754.
- Mendel, J.M. (1973). *Discrete Techniques of Parameter Estimation*. M. Dekker New York.
- Papusha, I., Lavretsky, E., and Murray, R.M. (2014). Collaborative system identification via parameter consensus. In *2014 American Control Conference*, 13–19.
- Rao, G., Diekmann, K., and Unbehauen, H. (1984). Parameter estimation in large scale interconnected systems. *IFAC Proceedings Volumes*, 17(2), 729 – 733. 9th IFAC World Congress, Hungary, 2-6 July 1984.
- Steentjes, T.R.V., Lazar, M., and Van den Hof, P.M.J. (2018). A recursive estimation approach to distributed identification of large-scale multi-input-single-output FIR systems. *ArXiv e-prints*, arXiv:1807.08141.
- Udink ten Cate, A.J. (1979). A least-squares like gradient algorithm for discrete model reference adaptive systems. *IFAC Proceedings Volumes*, 12(7), 179 – 184. IFAC Symposium on Computer Aided Design of Control Systems, Zurich, Switzerland, 29-31 August.
- Van den Hof, P.M.J., Dankers, A.G., Heuberger, P.S.C., and Bombois, X. (2013). Identification of dynamic models in complex networks with prediction error methods – Basic methods for consistent module estimates. *Automatica*, 49(10), 2994 – 3006.