

# Packed bed Ca-Cu looping process integrated with a natural gas, combined cycle for low emission power production

**Citation for published version (APA):**

Martini, M., Martinez, I., Gallucci, F., Romano, M. C., Chiesa, P., & van Sint Annaland, M. (2017). Packed bed Ca-Cu looping process integrated with a natural gas, combined cycle for low emission power production. *Energy Procedia*, 114, 104-112. <https://doi.org/10.1016/j.egypro.2017.03.1153>

**Document license:**

CC BY-NC-ND

**DOI:**

[10.1016/j.egypro.2017.03.1153](https://doi.org/10.1016/j.egypro.2017.03.1153)

**Document status and date:**

Published: 01/01/2017

**Document Version:**

Publisher's PDF, also known as Version of Record (includes final page, issue and volume numbers)

**Please check the document version of this publication:**

- A submitted manuscript is the version of the article upon submission and before peer-review. There can be important differences between the submitted version and the official published version of record. People interested in the research are advised to contact the author for the final version of the publication, or visit the DOI to the publisher's website.
- The final author version and the galley proof are versions of the publication after peer review.
- The final published version features the final layout of the paper including the volume, issue and page numbers.

[Link to publication](#)

**General rights**

Copyright and moral rights for the publications made accessible in the public portal are retained by the authors and/or other copyright owners and it is a condition of accessing publications that users recognise and abide by the legal requirements associated with these rights.

- Users may download and print one copy of any publication from the public portal for the purpose of private study or research.
- You may not further distribute the material or use it for any profit-making activity or commercial gain
- You may freely distribute the URL identifying the publication in the public portal.

If the publication is distributed under the terms of Article 25fa of the Dutch Copyright Act, indicated by the "Taverne" license above, please follow below link for the End User Agreement:

[www.tue.nl/taverne](http://www.tue.nl/taverne)

**Take down policy**

If you believe that this document breaches copyright please contact us at:

[openaccess@tue.nl](mailto:openaccess@tue.nl)

providing details and we will investigate your claim.



13th International Conference on Greenhouse Gas Control Technologies, GHGT-13, 14-18  
November 2016, Lausanne, Switzerland

## Packed Bed Ca-Cu Looping Process Integrated with a Natural Gas Combined Cycle for Low Emission Power Production

Michela Martini<sup>a</sup>, Isabel Martínez<sup>b</sup>, Fausto Gallucci<sup>a\*</sup>, Matteo C. Romano<sup>b</sup>, Paolo  
Chiesa<sup>b</sup>, Martin van Sint Annaland<sup>a</sup>

<sup>a</sup>Eindhoven University of Technology, Groene Loper 5, Eindhoven, The Netherlands

<sup>b</sup>Politecnico di Milano, Department of Energy, Via Lambruschini 4, Milano, Italy

---

### Abstract

This work investigates the full process design of a natural gas combined cycle integrated with a packed-bed reactor system where a hydrogen rich gas is produced with inherent CO<sub>2</sub> capture based of the CaO/CaCO<sub>3</sub> and Cu/CuO chemical loops. The different stages of this Ca-Cu process were modelled with a dynamic 1D pseudo-homogeneous model, proposing a novel reactor configuration allowing to achieve carbon capture efficiency close to 90%. Process simulations of the whole power plant resulted in electric efficiencies of around 48%<sub>LHV</sub> and SPECCA of 4.7 MJ/kg<sub>CO2</sub>.

© 2017 The Authors. Published by Elsevier Ltd. This is an open access article under the CC BY-NC-ND license (<http://creativecommons.org/licenses/by-nc-nd/4.0/>).

Peer-review under responsibility of the organizing committee of GHGT-13.

*Keywords:* Power production; Chemical looping; Modeling; Sorption enhanced reforming; CO<sub>2</sub> capture.

---

---

\* Corresponding author. Tel.: +31-40-247-3675.

E-mail address: [f.gallucci@tue.nl](mailto:f.gallucci@tue.nl)

## 1. Introduction

Natural gas combined cycle (NGCC) is nowadays the most advanced and common technology for producing electricity from natural gas with rather low emissions and high electric efficiencies [1]. There are three different ways to introduce a CO<sub>2</sub> capture system into a NGCC system: i) removing the CO<sub>2</sub> from the flue gas using a post-combustion capture system; ii) producing a syngas from natural gas reforming and separating the CO<sub>2</sub> pre-combustion to produce a H<sub>2</sub>-based fuel to be burned into the combustor of a gas turbine; iii) burning the natural gas with oxygen in a gas cycle and remove the CO<sub>2</sub> after water condensation.

This work is focused on the second approach, using the novel Ca-Cu process for H<sub>2</sub> production with inherent CO<sub>2</sub> capture proposed by Abanades et al. [2]. This process is based on the sorption enhanced reforming (SER) of natural gas in the presence of a CO<sub>2</sub> sorbent at high pressure and high temperature. In this way, the heat needed to drive the endothermic steam-methane reforming reaction is provided by the energy liberated by the CaCO<sub>3</sub> formation reaction. At the same time, the heat required to regenerate the CaCO<sub>3</sub> formed is matched with in situ heat production through the reduction of CuO to Cu by a fuel. The whole process can be divided into the following three main steps:

- the production of a pressurized hydrogen-rich stream via the sorption enhanced reforming (SER) of natural gas;
- the oxidation of Cu to CuO with air at high pressure and moderate temperature in order to limit the decomposition of CaCO<sub>3</sub>;
- the calcination of CaCO<sub>3</sub> at low pressure thanks to the energy released by the reduction of CuO with a fuel gas.

The objective of this work is to study through process simulations the integration of the Ca-Cu process in a combined cycle power plant with the aim of producing electricity with low CO<sub>2</sub> emissions. The behavior of the packed-bed reactor system has been assessed with a 1-D pseudo-homogeneous model developed in a previous work [3] under a set of reasonable conditions. An improved operational sequence for the Ca-Cu process is proposed in this work, which has been selected to improve the carbon capture efficiency with respect to the basic configuration proposed in previous work. The performance obtained from the mass and energy balances have been compared with a state-of-the-art NGCC without CO<sub>2</sub> capture and with a NGCC with pre-combustion CO<sub>2</sub> capture by benchmark MDEA absorption system.

### Nomenclature

ATR	Autothermal Reforming
CCE	Carbon Capture Efficiency
GT	Gas Turbine
HP	High Pressure
HRSG	Heat Recovery Heat Generation
LHV	Low Heating Value
LP	Low Pressure
MDEA	N-methyl-diethanolamine
NG	Natural Gas
NGCC	Natural Gas Combined Cycle
SER	Sorption Enhanced Reforming
SPECCA	Specific Primary Energy Consumption for CO <sub>2</sub> Avoided
WGS	Water Gas Shift

## 2. Process description

### 2.1. Ca-Cu process

A detailed process scheme of this Ca-Cu process configuration is shown in Fig. 1. As can be seen, the Ca-Cu process consists of a system of packed-bed reactors operating at different temperatures and pressures, where stages of sorption enhanced reforming (A and A'), Cu oxidation (B), bed heating (B') and CaCO<sub>3</sub> calcination/CuO reduction (C) occur. At the beginning of the first stage of the Ca-Cu process (A), the solid bed contains calcined CaO-based sorbent and reduced Cu-based material. Pre-reformed NG is fed into the bed in stage A' at high pressure after being heated up to around 700 °C. Reforming, water gas shift and carbonation take place in this stage. The H<sub>2</sub>-rich gas stream that results from this reaction equilibrium is cooled down from 850 °C to around 700 °C and fed into stage A where the carbon slipped from stage A' reacts with the CaO in the bed. This intermediate gas cooling is introduced to boost CO<sub>2</sub> capture through the carbonation reaction, which is favoured at low temperature.

Once the SER stage has finished, the Cu present in the bed is oxidized to CuO. Due to the exothermicity of the oxidation reaction, it is important to control the maximum temperature reached inside the reactor by limiting the temperature and the O<sub>2</sub> concentration of the gas fed to stage B [4]. High temperatures in the bed (above 850 °C) would lead to an irreversible loss of Cu activity and partial premature calcination of CaCO<sub>3</sub> formed during stage A. Due to the reduced temperature of the diluted air fed to stage B, the packed bed will be at a very low temperature at the end of this stage, and therefore an intermediate heating stage between stages B and C needs to be included (indicated as B' in Fig. 1) for allowing stage C to initiate. Since recycled O<sub>2</sub>-depleted gas should be cooled down to be mixed with compressed air, it is proposed to heat the solid bed during stage B' by extracting heat from this recycled O<sub>2</sub>-depleted gas making it pass through the solid bed.

The last stage of the Ca-Cu process (stage C) consists of the regeneration of the CaCO<sub>3</sub> formed during stage A by means of the exothermic reduction of the CuO formed during stage B. A proper Cu/CaO molar ratio should be chosen such that the heat released by the exothermic reduction of CuO with CH<sub>4</sub>, CO and/or H<sub>2</sub> matches the requirement of the endothermic calcination of the CaCO<sub>3</sub> formed in stage A [4]. To avoid calcination temperatures exceeding 900-950 °C, which would reduce CaO and Cu reactivity, the operating pressure of stage C should be close to atmospheric to ensure a sufficient driving force for sorbent calcination. Pre-reformed NG is fed into this stage C coming from a heated pre-reformer at 700 °C in order to obtain a bed with uniform temperature at the beginning of stage A, stabilizing the Ca-Cu loop and preventing the risk of sorbent hydration. The steam-to-carbon ratio used for this pre-reforming is around 1, which is enough to avoid carbon formation during stage C, but ensures that syngas coming from the heated pre-reformer at 700 °C contains enough H<sub>2</sub> and CO to reduce the CuO. The gas at stage C outlet, which contains mainly CO<sub>2</sub> and H<sub>2</sub>O, is cooled down before being sent to the CO<sub>2</sub> compressor for its storage. At the end of stage C, the solid bed remains at around 700 °C and nearly atmospheric pressure and so it needs a re-pressurization stage before starting with a new cycle.

This process was modelled with a dynamic 1D pseudo-homogeneous model [3]. This model calculates the mass and energy balances of adiabatic fixed bed reactors taking into account axial mass dispersion, effective heat conductivity and gas/solids heterogeneous reactions and SMR/WGS homogeneous reactions kinetics. No radial temperature and concentration gradients are considered and mass and heat transfer resistances between the gas and solid phase are neglected, leading to a homogeneous description of temperature and components.

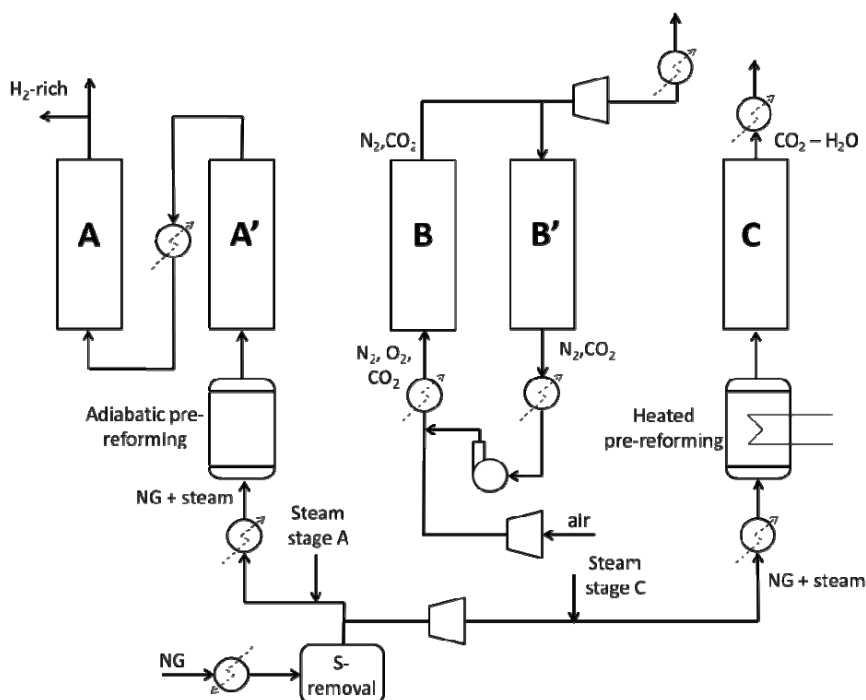

Fig. 1. Scheme of the Ca-Cu process with two beds in series for stage A and intermediate gas cooling.

## 2.2. Power plant

The proposed integration of the Ca-Cu process in a full-scale combined cycle-based power plant is shown in Fig. 2. NG entering into the plant (stream #1) is purified from sulfur species and sent to a high temperature desulfurization unit composed of a hydrogenator reactor and a ZnO bed for H<sub>2</sub>S sorption. NG is then split into two streams: the first one, at high pressure, is mixed with steam to be pre-reformed in an adiabatic pre-reformer and sent to stage A' of the Ca-Cu process (stream #5); the other stream is expanded, mixed with LP steam, sent to a heated pre-reformer and then fed to stage C of the Ca-Cu process (stream #4). Both the HP and the LP natural gas streams are mixed with steam in different steam-to-carbon (S/C) ratios and pre-reformed in order to reduce the risk of carbon deposition in the packed beds of the Ca-Cu process, which may occur in the initial part of the bed when active sorbent and oxidized oxygen carrier are not available during stages A and C respectively.

As can be appreciated in Fig. 2, the power island in the proposed configuration consists of a combined cycle that uses H<sub>2</sub>-rich gas produced in the Ca-Cu process as fuel in the combustor of the GT. Air needed for stage B of the Ca-Cu process is split from the compressed air from the GT compressor. Due to the difference between the operating pressure of the oxidation stage of the Ca-Cu process and the pressure at the compressor outlet, an additional booster compressor is included. Flue gas from the gas turbine (stream #13) is cooled down in a heat recovery steam generator (HRSG) that feeds a state-of-the-art three-pressure level with reheat steam cycle. A fraction of the H<sub>2</sub>-rich gas coming from the Ca-Cu process is sent to an auxiliary combustor with a minor fraction of the flue gas exiting the gas turbine to provide the energy needed in the LP gas heated pre-reformer. Gas at the exit of this heated pre-reformer is sent to the HRSG together with the GT exhaust. Most of the steam used in the steam turbine is generated from flue gas cooling in the HRSG, whereas available hot gas streams from the Ca-Cu process are mostly used for pre-heating the NG and pre-reformed NG streams fed into the Ca-Cu process.

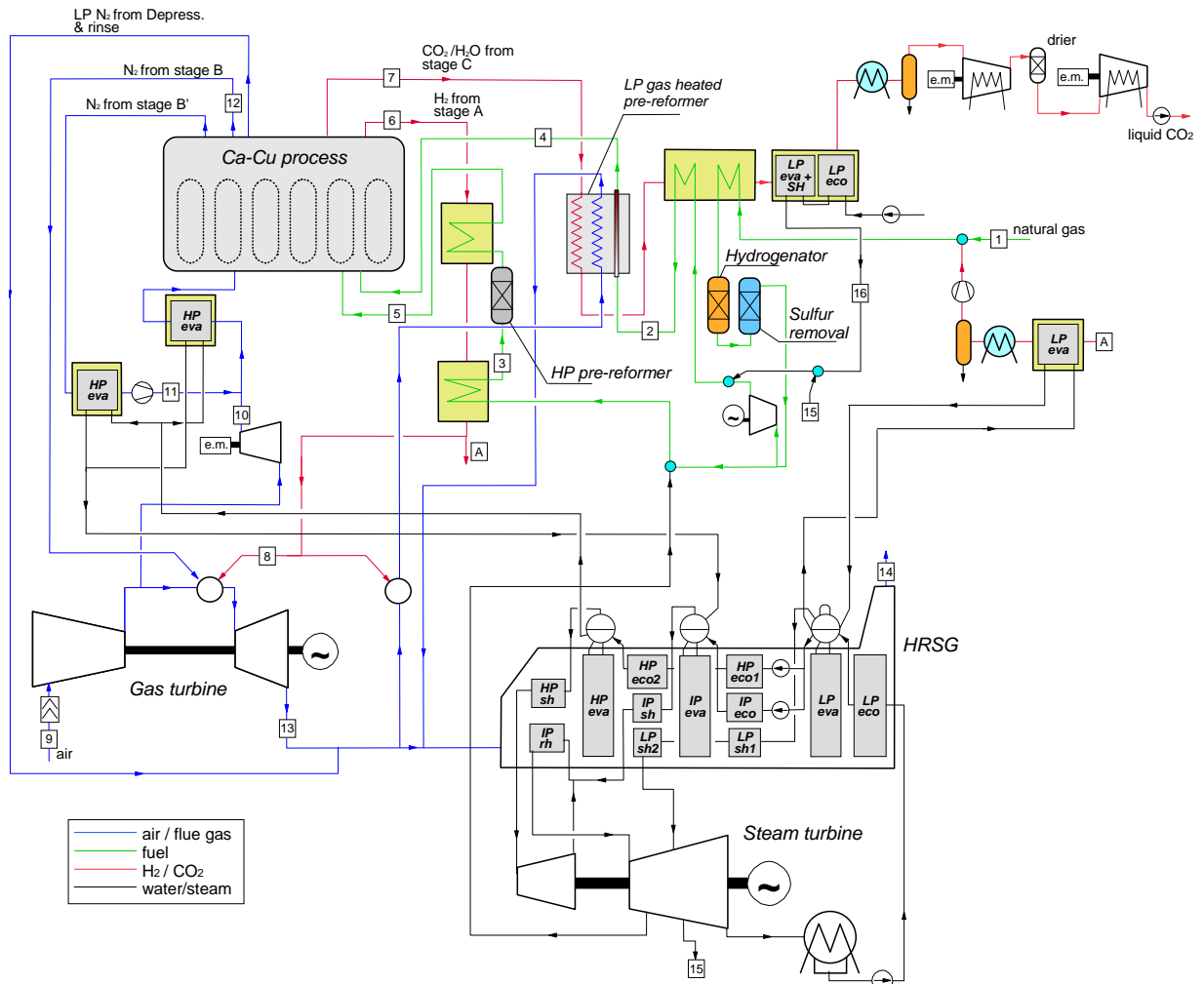

Fig. 2. Schematic of the Ca-Cu process integrated in a full scale combined cycle power plant.

### 3. Process assumption and methodology

Mass and energy balances of the proposed process were calculated using the Politecnico di Milano in-house code GS [5], implementing the information obtained from a dynamic pseudo-homogeneous model (PHM), used for modelling the behavior of the Ca-Cu process [3]. Average composition and temperature of the outlet streams of the different steps of the process were considered for the calculations of the performances of the complete power plant.

For these calculations the following solids composition were considered: a CaO-based material as CO<sub>2</sub> sorbent with 85 wt.% of CaO (30% of which active on CO<sub>2</sub> sorption) on Al<sub>2</sub>O<sub>3</sub>, a 65 wt.% Cu material on an Al<sub>2</sub>O<sub>3</sub> carrier and Ni catalyst (18% Ni on Al<sub>2</sub>O<sub>3</sub>). A Ca/Cu molar ratio of 1.7 was calculated to match the heat of reactions in step C. A catalyst-to-sorbent molar ratio of 0.3 was selected following literature [6]. Pressure, initial temperature and steam-to-carbon (S/C) ratio at stage A have been chosen such to avoid Ca(OH)<sub>2</sub> formation according to thermodynamic. The power island has been calculated with assumptions consistent with the EBTF methodology [7].

## 4. Results and discussion

### 4.1. Ca-Cu process

Simulations of the process scheme with the double SER stage shown in Fig. 1 were then performed for an operating pressure of 25 and 21 bar in stage A-A' and B-B', respectively, and an S/C of 5 at the inlet of the HP adiabatic pre-reformer. In Fig. 3 the axial temperature and active CaO sorbent conversion profiles inside the bed during stage A at different time instants are shown. It can be seen that in this stage the CaO is converted slowly due to the low carbon content in the gases coming from stage A'. In the first part of the bed where the solid is already carbonated, only reverse steam methane reforming (i.e. methanation) and water gas shift occur, which heat the bed up to the adiabatic equilibrium temperature of these two reactions. When the gas reaches the unreacted CaO, the carbonation reaction occurs and the temperature increases until the maximum temperature is reached, that correspond to the equilibrium temperature of the carbonation reaction. At this point no CaO is converted until the temperature decreases to the initial bed temperature in the final part of the bed, where carbonation reaction is favored by thermodynamics.

The final profiles of stage A correspond to the initial condition of stage A'. In Fig. 4 the axial temperature and solid composition profiles inside the bed at different time instants during stage A' are shown. It can be seen that the behavior of this step is similar to stage A but with a much faster reaction front due to the higher carbon content in the feed gas of this step. At the entrance of the bed, when the CaO has already been carbonated, the gas fed reacts according to reforming and water gas shift reactions until the equilibrium of both reactions is reached. The bed temperature decreases in this case due to the advancement of the steam methane reforming reaction. In the part of the bed where CaO is available, the carbonation reaction takes place and the temperature increases up to the equilibrium temperature. The temperature profiles of steps B, B' and C are not discussed in this paper since their behavior is similar to previous studies available in literature [5,9].

Simulations of the entire process were carried out and operating pressure of 25 bar, feed temperatures of 700 °C and 500 °C for stage A and A' respectively and S/C ratio 5 were selected. These process parameters allowed to reach a good compromise between efficiency and CO<sub>2</sub> emissions of the complete power plant as discussed in the following section.

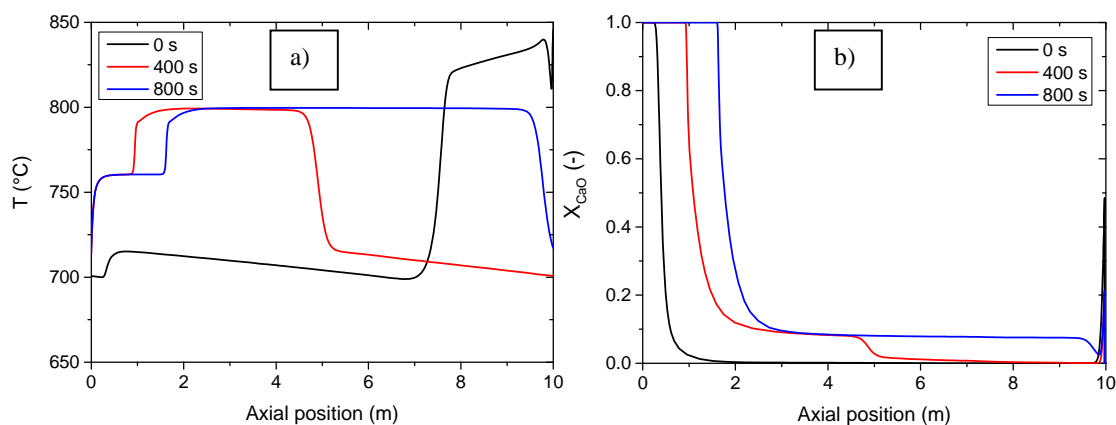

Fig. 3. Axial temperature (a) and CaO conversion (b) profiles inside the bed during step A at different moments in time: at the beginning of stage A (—), at an intermediate time (—) and at the end (—).

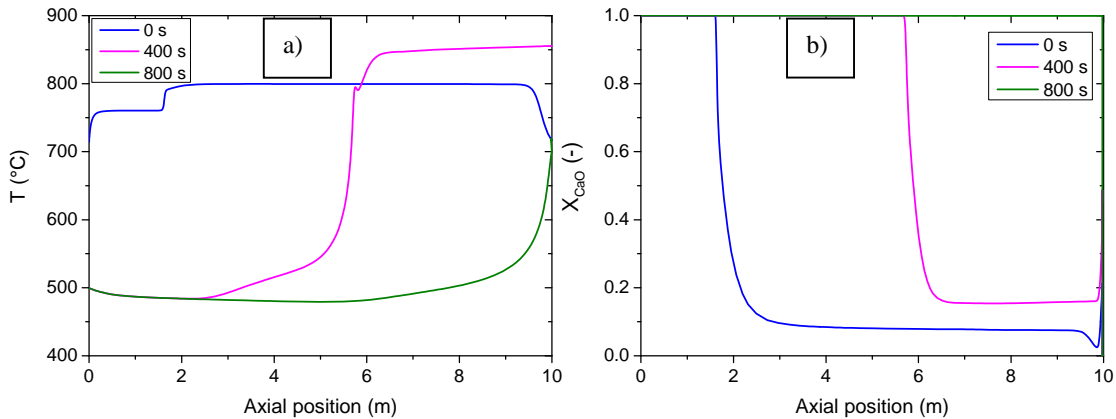

Fig. 4. Axial temperature (a) and CaO conversion (b) profiles inside the bed during step A' at different moments in time: at the beginning of stage A' (—), at an intermediate time (—) and at the end (—).

#### 4.2. Plant performance results and comparison with the benchmark plants

The energy balance of the NGCC plant integrated with the Ca-Cu process scheme is reported in Table 1, together with the NGCC benchmark plants without CO<sub>2</sub> capture and with pre-combustion CO<sub>2</sub> capture by autothermal reforming (ATR) and CO<sub>2</sub> absorption by MDEA solution, adapted from [10]. In the Ca-Cu plant an overall carbon capture efficiency of 86.9 % was obtained. An electric efficiency of 47.8 % was obtained, 10.7 % points less than the reference NGCC without CO<sub>2</sub> capture and 0.65 % points higher than the efficiency of the reference NGCC with pre-combustion CO<sub>2</sub> capture. To better compare the performance the specific primary energy for CO<sub>2</sub> avoided (SPECCA) was also calculated:

$$SPECCA = \frac{\left( \frac{1}{\eta_{LHV}} - \frac{1}{\eta_{LHV-ref}} \right)}{E_{ref} - E} \cdot 3600$$

where  $\eta_{LHV}$  is the net electric efficiency,  $E$  is the specific CO<sub>2</sub> emission and  $ref$  indicated the NGCC reference case without CO<sub>2</sub> capture. A SPECCA of 4.68 MJ/kgCO<sub>2</sub> results for the analyzed case, which is slightly below the SPECCA reported for the reference NGCC with CO<sub>2</sub> capture.



Table 1. Energy balance and performance comparison of the Ca-Cu power plant and the benchmark NGCC with and without CO<sub>2</sub>

	NGCC w/o capture	NGCC with capture by ATR and MDEA	NGCC + Ca-Cu process
Gas turbine gross power	273.2	291.3	316.2
Gas turbine auxiliaries	-1.09	-1.17	-1.26
Steam turbine gross power	147.1	119.7	173.5
Steam Cycle Pumps power	-1.79	-3.41	-3.31
Auxiliaries for condenser heat rejection	-1.86	-1.09	-1.56
Air booster compressor power		-10.91	-3.83
MDEA plant auxiliaries		-5.13	--
O <sub>2</sub> -depleted gas recycle fan		--	-22.6
CO <sub>2</sub> compressor power		-14.73	-16.10
Auxiliaries for heat rejection other than condenser		-1.06	-0.66
Natural gas expansion		--	3.25
Other auxiliaries		-0.19	--
Net power, MW <sub>e</sub>	415.6	373.3	443.6
Thermal input, MW <sub>LHV</sub>	711.3	792.2	928.7
Net electric efficiency, % <sub>LHV</sub>	58.42	47.12	47.77
Carbon capture ratio, %		91.56	86.86
Specific emissions, kg/MWh	350.6	36.66	56.71
CO <sub>2</sub> avoided, %		89.54	83.8
SPECCA, MJ <sub>LHV</sub> /kg <sub>CO2</sub>		4.71	4.68

## 5. Conclusion

In this work the integration of the Ca-Cu process in a combined cycle power plant has been assessed. Mass and energy balances of the complete power plant were solved, assessing the behavior of the Ca-Cu process using a 1-D pseudo-homogeneous model. An improved scheme has been proposed in this work for the Ca-Cu process, aiming at increasing the CO<sub>2</sub> capture efficiency with respect to the base configuration. A CO<sub>2</sub> capture efficiency of about 87 % was obtained that is slightly lower than the CCE achieved in the reference NGCC including pre-combustion CO<sub>2</sub> capture by ATR and MDEA processes. The net electric efficiency and the SPECCA calculated for the Ca-Cu-based plant are, 47.8 % and 4.68 MJ/kgCO<sub>2</sub>, respectively, which are slightly better than those reported for the reference plant used as a benchmark. Further investigations are ongoing in the framework of the ASCENT project aimed at improving the performance of the materials of the Ca-Cu process under a wide range of operating conditions.

## Acknowledgements

The presented work is funded within the ASCENT project as part of the European Union's Seventh Framework Programme (FP7/2007-2013) under grant agreement n° 608512. Note: "The present publication reflects only the authors' views and the European Union is not liable for any use that may be made of the information contained therein".

## References

- [1] Metz B, Davidson O, Bosch P, Dave R, Meyer L. Mitigation of climate change: Contribution of working group III to the fourth assessment report of the Intergovernmental Panel on Climate Change. 2007.
- [2] Abanades JC, Murillo R, Fernandez JR, Grasa G, Martínez I. New CO<sub>2</sub> capture process for hydrogen production combining Ca and Cu chemical loops. Environ Sci Technol 2010;44:6901–4.
- [3] Martini M, van den Berg a, Gallucci F, van Sint Annaland M. Investigation of the process operability windows for Ca-Cu looping for hydrogen production with CO<sub>2</sub> capture. Chem Eng J 2016;303:73–88.
- [4] Fernández JR, Abanades JC, Murillo R, Grasa G. Conceptual design of a hydrogen production process from natural gas with CO<sub>2</sub> capture using a Ca–Cu chemical loop. Int J Greenh Gas Control 2012;6:126–41.
- [5] Gecos. GS Software 2015.

- [6] Fernandez JR, Abanades JC, Grasa G. Modeling of sorption enhanced steam methane reforming-Part II: Simulation within a novel Ca/Cu chemical loop process for hydrogen production. *Chem Eng Sci* 2012;84:12–20.
- [7] Politecnico di Milano – Alstom UK (CAESAR project). European best practice guidelines for assessment of CO<sub>2</sub> capture technologies. 2011.
- [8] Fernandez JR, Abanades JC, Murillo R. Modeling of Cu oxidation in an adiabatic fixed-bed reactor with N<sub>2</sub> recycling in a Ca/Cu chemical loop. *Chem Eng J* 2013;232:442–52.
- [9] Murillo R, Grasa G, Fern JR, Abanades JC, Nacional I. Integrated Combined Cycle from Natural Gas with CO<sub>2</sub> Capture Using a Ca – Cu Chemical Loop 2013;59.
- [10] Romano MC, Chiesa P, Lozza G. Pre-combustion CO<sub>2</sub> capture from natural gas power plants, with ATR and MDEA processes. *Int J Greenh Gas Control* 2010;4:785–97.