

Semiconductor optical amplifiers and raman amplification for 1310-nm wavelength division multiplexed transmission

Citation for published version (APA):

Mazurek, P., Czyzak, P., de Waardt, H., & Turkiewicz, J. (2015). Semiconductor optical amplifiers and raman amplification for 1310-nm wavelength division multiplexed transmission. *Optical Engineering*, 54(11).
<https://doi.org/10.1117/1.OE.54.11.116104>

DOI:

[10.1117/1.OE.54.11.116104](https://doi.org/10.1117/1.OE.54.11.116104)

Document status and date:

Published: 16/11/2015

Document Version:

Accepted manuscript including changes made at the peer-review stage

Please check the document version of this publication:

- A submitted manuscript is the version of the article upon submission and before peer-review. There can be important differences between the submitted version and the official published version of record. People interested in the research are advised to contact the author for the final version of the publication, or visit the DOI to the publisher's website.
- The final author version and the galley proof are versions of the publication after peer review.
- The final published version features the final layout of the paper including the volume, issue and page numbers.

[Link to publication](#)

General rights

Copyright and moral rights for the publications made accessible in the public portal are retained by the authors and/or other copyright owners and it is a condition of accessing publications that users recognise and abide by the legal requirements associated with these rights.

- Users may download and print one copy of any publication from the public portal for the purpose of private study or research.
- You may not further distribute the material or use it for any profit-making activity or commercial gain
- You may freely distribute the URL identifying the publication in the public portal.

If the publication is distributed under the terms of Article 25fa of the Dutch Copyright Act, indicated by the "Taverne" license above, please follow below link for the End User Agreement:

www.tue.nl/taverne

Take down policy

If you believe that this document breaches copyright please contact us at:

openaccess@tue.nl

providing details and we will investigate your claim.

SOA and Raman amplification for 1310 nm DWDM transmission

Pawel Mazurek^a, Pawel Czyżak^b, Huug de Waardt^c, Jarosław Piotr Turkiewicz^b

^aInstitute of Radioelectronics, Faculty of Electronics and Information Technology, Warsaw University of Technology, ul. Nowowiejska 15/19, 00-665 Warsaw, Poland

^bInstitute of Telecommunications, Faculty of Electronics and Information Technology, Warsaw University of Technology, ul. Nowowiejska 15/19, 00-665 Warsaw, Poland

^cCOBRA Research Institute, Eindhoven University of Technology, Eindhoven 5600MB, The Netherlands

Abstract. In this paper, we investigate the utilisation of the semiconductor optical amplifiers and quantum-dot laser based Raman amplifier in the high capacity dense wavelength division multiplexed 1310 nm transmission systems. Performed simulations showed that in a 10×40 Gbit/s system the utilisation of the single Raman amplifier in a back-propagation scheme can extend the maximum error-free (bit error rate $< 10^{-9}$) transmission distance by approximately 25 km in comparison with the same system utilising only the semiconductor optical amplifier used as a preamplifier. We successfully applied a Raman amplifier in the 8×2×40 Gbit/s 1310 nm polarization and dense wavelength division multiplexed transmission over 25 km. Conducted experiments showed that the utilisation of a Raman amplifier in this system leads to the 4 dB improvement of the average channel sensitivity in comparison with the same system utilising the semiconductor optical amplifiers. This sensitivity improvement can be translated into the higher power budget. Moreover, lower input optical power in a system utilising Raman amplifier reduces the four-wave mixing interactions. Obtained results prove that the Raman amplification can be successfully applied in the 1310 nm high capacity transmission systems *e.g.* to extend the reach of the 400G and 1T Ethernet systems.

Keywords: 1310 nm, semiconductor optical amplifier, Raman amplifier, data communication, dense wavelength division multiplexing, polarization multiplexing

Address all correspondence to: Pawel Mazurek, Institute of Radioelectronics, Faculty of Electronics and Information Technology, Warsaw University of Technology, ul. Nowowiejska 15/19, 00-665 Warsaw, Poland; e-mail: p.mazurek@ire.pw.edu.pl; tel.: +48 22 234-7629

1 Introduction

The increasing capacity demand on the short and medium range high capacity optical transmission systems, utilised in *e.g.* local area networks (LAN), metropolitan area networks (MAN) and data/storage centre interconnections, has resulted in a growing interest in the 1310 nm wavelength domain.¹⁻⁴ Moreover, utilisation of this transmission window is a promising solution for a legacy fibre system capacity upgrade, since it does not require very expensive installation of new fibres and, in addition, the 1310 nm wavelength domain can be used in parallel to the 1550 nm one. The 1310 nm window has the advantages of reduced chromatic dispersion related distortions and a wide availability of components.

To fully explore the potential of the 1310 nm transmission, efficient amplification techniques are needed. Until recently, the only practical way to extend the reach of the 1310 nm transmission system was the utilisation of ~~the~~ semiconductor optical amplifiers (SOAs).^{1,2} Other solutions like Raman amplifiers and praseodymium doped fibre amplifiers (PDFAs) were not widely implemented because of their high cost and moderate performance ~~were not widely implemented~~.

The recent progress in the development of ~~the~~ high power 1240 nm quantum-dot (QD) lasers⁵ has caused ~~the~~ decrease of ~~the~~ Raman amplifier costs and thus made it more competitive with the SOA amplifier. ~~The presented so far~~ research presented so far on the 1310 nm Raman amplification includes work on the discrete Raman amplifiers, where the special highly-nonlinear fibres are used.^{6,7} This solution does not leverage one of the key Raman amplifier advantages, which is the utilisation of the transmission fibre as an amplification medium. In Ref. 8–11, the use of the distributed Raman amplifiers as ~~the~~ reach extenders limited to the passive optical networks (PONs) is described. In Ref. 12 detailed studies regarding the design and static performance of the 1310 nm Raman amplifier utilising quantum-dot (QD) pumping lasers have been presented.

In this paper, we investigate the utilisation of semiconductor optical amplifiers and laser based Raman amplifier in a high capacity polarization multiplexed (PolMux) and dense wavelength division multiplexed (DWDM) 1310 nm transmission system. Through simulations, we investigate the impact of the different amplification schemes (based on SOA preamplifier and Raman amplifier) on the transmission quality of a in the 1310 nm window 10×40 Gbit/s (400 Gbit/s) DWDM system operating in the 1300 nm window. Simulations showed that the utilisation of a Raman amplifier in a back-propagation scheme allows a much longer error-free (BER < 10⁻⁹) transmission (*ca.* 55 km) than the utilisation of a single SOA preamplifier (*ca.* 30 km). Moreover, we experimentally compare the performance

of ~~the~~an SOA amplifier and ~~a~~Raman amplifier in ~~at~~the high capacity 8×2×40 Gbit/s (640 Gbit/s) PolMux DWDM 1310 nm transmission system with ~~at~~the transmission distance of 25 km standard single mode fibre (SSMF). We analyze two systems: the first one utilises ~~an~~SOA booster amplifier and ~~an~~the SOA preamplifier, while the second employs ~~a~~distributed Raman amplifier using the transmission line as a gain medium and ~~an~~the SOA preamplifier. Conducted experiments showed superior performance of the system utilising Raman amplification~~ier~~ with ~~a~~ the receiver sensitivity improvement of 4 dB, which translates to *ca.* 10 km longer transmission distance. Moreover, lower optical power at the fibre input, in case of ~~a~~Raman amplification, reduces four-wave mixing (FWM) interactions and thus allows the decrease of the channel spacing. Finally, the sensitivity gain can be used to eliminate ~~the~~ necessity for forward error correction (FEC) and therefore reduces~~s~~ latency. Obtained results lead to the conclusion that ~~the~~Raman amplification~~s~~ can~~be~~ successfully ~~be~~ applied in the 1310 nm DWDM high capacity transmission systems *e.g.* to extend the reach of the 400G and 1T Ethernet systems, with the reach of few dozen kilometres.

2 Impact of Different Amplification Schemes on the Transmission Quality ~~of a in the~~ ~~1310 nm Window~~ 400 Gbit/s DWDM System ~~operating in the 1300 nm window~~

To investigate the impact of different amplification schemes on the transmission quality in the 1310 nm wavelength domain, a series of simulation experiments were made. ~~A~~The 10×40 Gbit/s system with the total capacity of 400 Gbit/s was implemented. The following schemes ~~were studied~~: a single SOA preamplifier and a single Raman amplifier in a back propagation configuration were compared with respect to the maximum error-free (BER<10⁻⁹) transmission distance. The back propagation was chosen due to ~~the~~better amplification properties.¹²

2.1 Single SOA Preamplifier

Figure 1 shows measured characteristics of the SOA amplifier used in the experiments:

amplifier gain as in the function of the wavelength (Fig. 1A), amplifier gain as in the function of the output optical power (Fig. 1B), amplified spontaneous emission (ASE) noise density as in the function of the wavelength (Fig. 1C), and ASE noise density as in the function of the output optical power (Fig. 1D), for different values of the injection current. It may be observed that the peak gain of the SOA amplifier is *ca.* 17 dB and this value corresponds to the wavelength of 1285 nm. The 1 dB amplification bandwidth of the amplifier is *ca.* 40 nm, while its saturation output power is *ca.* 13 dBm.

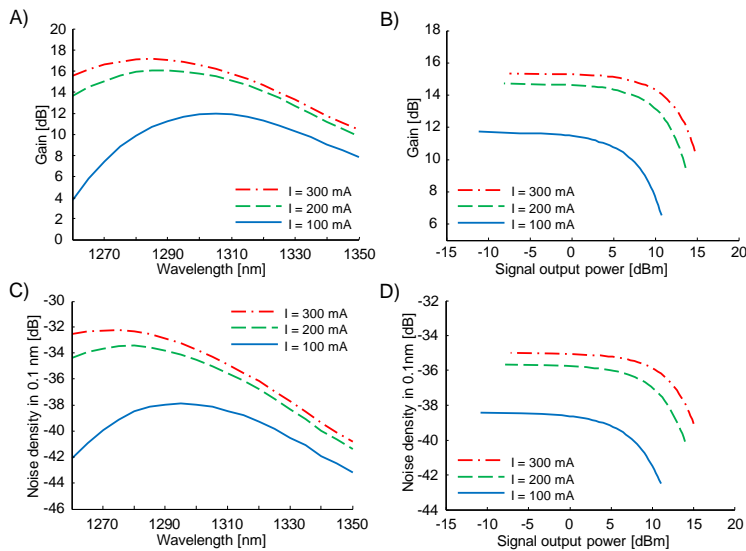

Fig. 1 The measured characteristics of the SOA amplifier used in the experiments:

Amplifier gain as in the function of the wavelength (A), amplifier gain as in the function of the output optical power (B), amplified spontaneous emission (ASE) noise density as in the function of the wavelength (C), and ASE noise density as in the function of the output optical power (D), for different values of the injection current.

Figure 2A shows the setup used in the simulations investigating the maximum error-free (BER 10^{-9}) transmission distance in the of a 1310 nm wavelength domain 10×40 Gbit/s DWDM system utilising a single SOA preamplifier.

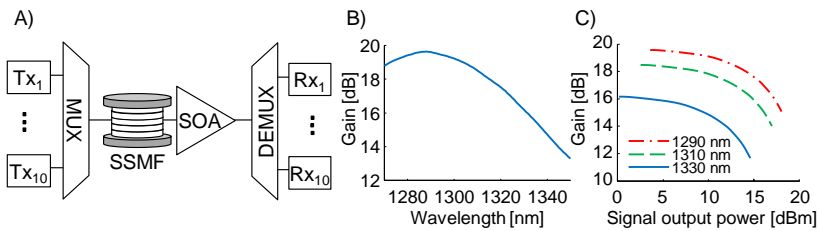

Fig. 2 The setup used in the simulations (A), the simulated SOA gain ~~as the~~ function of the wavelength (B), the simulated SOA gain ~~as the~~ function of the output power (C).

Each of the ten transmitters consisted of a DFB laser with a linewidth of 10 MHz and a random phase offset, and a modulator with the extinction ratio (ER) of 30 dB. In the modulator, the continuous wavelength (CW) light was non-return-to-zero (NRZ) on-off keying (OOK)-modulated with the line rate of 40 Gbit/s; therefore, the total system capacity was 400 Gbit/s. The channels wavelengths were symmetrically evenly allocated around the central wavelength of 1310 nm and the channel spacing was equal to 200 GHz. After multiplexing in an ideal wavelength multiplexer without any losses and intra-channel crosstalk, the signals were fed into the standard single mode fibre (SSMF) transmission line for which parameters were as follows: attenuation 0.35 dB/km, dispersion at 1310 nm 0 ps/nm×km and dispersion slope 0.08 ps/nm²×km. After the transmission line, the signals were amplified in the SOA, demultiplexed in an ideal lossless wavelength demultiplexer, and finally received in the following receivers, each of which consisted of the PIN photodiode with responsivity of 1 V/A followed by the fourth-order Bessel low-pass filter with the bandwidth of 30 GHz. In the receivers, the shot noise and thermal noise were taken into

account. ~~The output~~Optical power of each transmitter was set to 0 dBm, so, after multiplexing, the signal optical power was 10 dBm.

Figure 2B presents the simulated SOA amplifier gain as ~~a~~-function of the wavelength, while Fig. 2C shows the simulated amplifier gain as ~~the~~-function of the output power for different wavelengths.¹³ It is seen that the maximum gain of about 19.5 dB occurs for 1290 nm and the amplification bandwidth of the SOA is about 40 nm. Moreover, the average saturation output power is about 15 dBm which corresponds to the value of real components.

Table 1 presents the utilised parameters values of the SOA model. To simulate the amplifiers ASE noise, the Gaussian-distributed optical white noise source was utilised, followed by optical filter shaping the noise characteristics.

Table 1 Standard SOA module parameters.¹³

SOA parameter	Value [unit]
Injection Current	350 [mA]
Length	400 [μm]
Width	3 [μm]
Height	250 [nm]
OptConfinement	0.15
InternalLosses	4000 [1/m]
DifferentialGain	2.78×10^{-20} [m^2]
CarrierDensityTransp	1.4×10^{24} [$1/\text{m}^2$]
IndexToGainCoupl	3.0
RecombConstA	1.43×10^8 [1/s]
RecombConstB	1.0×10^{-16} [m^3/s]
RecombConstC	3.0×10^{-41} [m^6/s]
InitCarrierDens	4.0×10^{24} [$1/\text{m}^3$]

Figure 3 shows the BER for each channel as ~~a~~-function of the transmission distance.

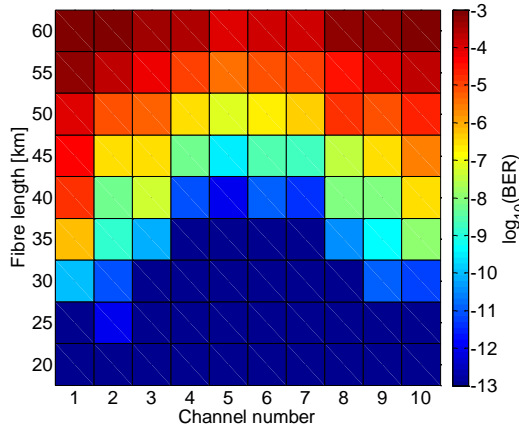

Fig. 3 The BER for each channel of the 400 Gbit/s WDM system utilising the SOA preamplifier, as the function of the transmission distance.

As it can be observed in the Fig. 3 the utilisation of a SOA preamplifier allows the error-free transmission with $BER < 10^{-9}$ over the distances up to 30 km. For longer distances the performance of the channels degrades significantly.

2.2 Single Raman Amplifier in a Back-Propagation Configuration

Figure 4 shows the measured characteristics of the Raman amplifier used in the experiments: amplifier gain as in the function of the wavelength for 25 km of SSMF transmission line (Fig. 4A), amplifier gain as in the function of the wavelength for 38 km of SSMF transmission line (Fig. 4B), amplifier noise figure as in the function of the wavelength for 25 km of SSMF transmission line (Fig. 4C), and amplifier noise figure as in the function of the wavelength for 38 km of SSMF transmission line (Fig. 4D), for different values of the 1240 nm pump power.

It may be observed that for the 25 km of SSMF the peak gain of the Raman amplifier is *ca.* 18 dB and this value corresponds to the wavelength of 1312 nm. The 1 dB amplification bandwidth of the amplifier is *ca.* 12 nm, while the noise figure is *ca.* 4 dB in the vicinity of the 1310 nm. For the 38 km of SSMF the peak gain of the Raman amplifier is *ca.* 20 dB and this value corresponds also to the wavelength of 1312 nm. As in the previous case, the 1 dB

amplification bandwidth of the amplifier is *ca.* 12 nm, and the noise figure is *ca.* 4 dB in the vicinity of the 1310 nm. All of those values ~~stay in agreement~~ with conducted simulations.¹²

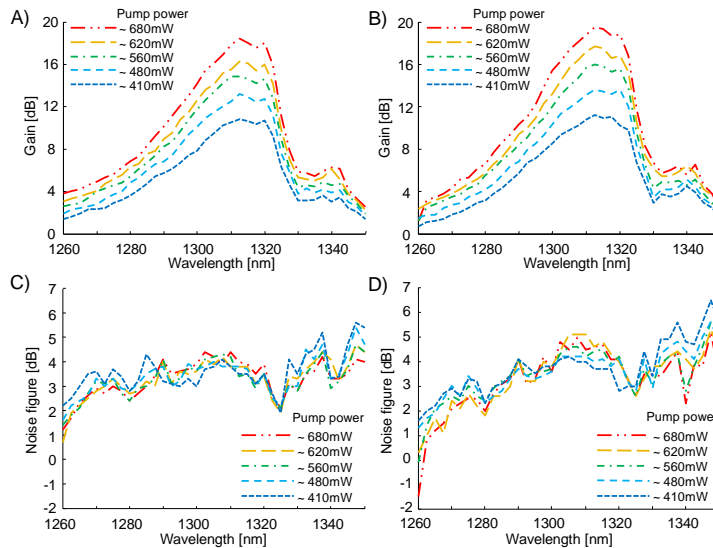

Fig. 4 The measured characteristics of the Raman amplifier used in the experiments:

amplifier gain ~~as in the~~ function of the wavelength for 25 km of SSMF (A) and 38 km of SSMF (B), and amplifier noise figure ~~as in the~~ function of the wavelength for 25 km of SSMF (C) and 38 km of SSMF (D), for different values of the pump power.

Figure 5A shows the setup used in the simulations investigating the maximum error-free (BER < 10^{-9}) transmission distance ~~of in~~ the 1310 nm wavelength domain 10×40 Gbit/s DWDM system utilising single Raman amplifier in a back-propagation configuration. The whole setup had the same settings as the one described in the previous section. The only difference was the Raman amplifier in the back-propagation ~~mode configuration used~~ instead of the SOA preamplifier.

Figure 5B presents the simulated Raman amplifier gain as ~~a~~ function of the wavelength while Fig. 5C shows the simulated amplifier gain as ~~the~~ function of the fibre length.¹² It can be seen that the maximum gain is achieved for a signal wavelength of 1310 nm. The 1-dB

gain bandwidth is 8 nm for a pump power of 1200 mW and it increases to 10 nm with a decrease of the pump power to 10 nm at 800 mW and to 18 nm at 400 mW. The Raman amplifier saturation output power is *ca.* 20 dBm. A decrease of the pump power from 1200 mW to 600 mW lowers the saturation power by only *ca.* 1 dB, from 20.3 dB to 19.1 dB.

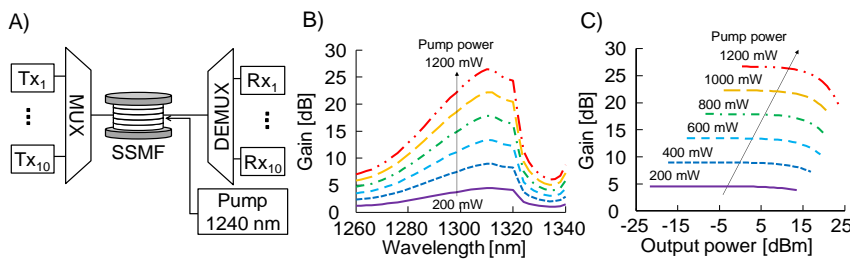

Fig. 5 The setup used in the simulations (A), the simulated Raman amplifier gain as the function of the wavelength for 40 km of SSMF (B), the simulated Raman amplifier gain as the function of the output power for $\lambda = 1310$ nm and 40 km SSMF (C).

Figure 6 shows the BER for each channel as a function of the transmission distance for two levels of the pump power: 400 mW (Fig. 6A) and 700 mW (Fig. 6B).

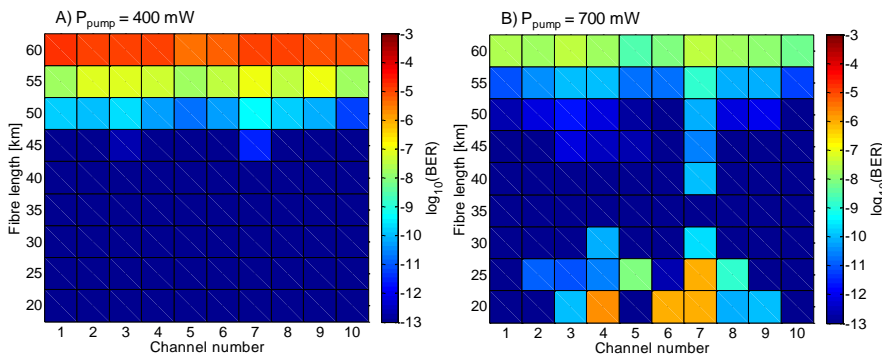

Fig. 6 The BER for each channel of the 400 Gbit/s WDM system utilising the Raman amplifier, as the function of the transmission distance for the pump power of 400 mW (A) and 700 mW (B).

As it can be observed in the Fig. 6 the utilisation of a single Raman amplifier in the back-propagation configuration allows the error-free transmission with $BER < 10^{-9}$ over the

distances up to 50 km for the pump power of 400 mW (Fig. 6A), and up to 55 km for the pump power of 700 mW (Fig. 6B). Over these distances the performance of the channels degrades as the result of the fibre attenuation. Moreover, it can be seen that for the pump power of 700 mW and for short distances of 20-25 km the performance of some channels degrades as the result of the Raman amplifier saturation, since the signal power at the output of the transmission line is *ca.* 15 dBm.

It can be seen that the system utilising the Raman amplifier performs ~~shows~~ remarkably better ~~performance~~ than the one utilising the SOA pre-amplifier. Not only the error-free transmission distance is longer, but also the quality of all channels is approximately the same. This superior performance can be attributed to the lower noise figure of the Raman amplifier as well as the lack of cross-gain modulation (XGM) and patterning effects.

3 Experimental Setups

The experimental setups utilising ~~the simulated investigated~~ amplification schemes are shown in Fig. 7. First scheme (Fig. 7A) utilises ~~a~~ SOA booster amplifier and ~~a~~ SOA preamplifier. The second scheme (Fig. 7B) assumes the utilisation of ~~a~~ Raman amplifier in a back-propagation scheme and ~~a~~ SOA preamplifier. In this scheme ~~a~~ SOA booster amplifier was not considered, since it would ~~introduce~~ cause too high optical power at the end of the transmission line and subsequently would drive the Raman amplifier into saturation as well as ~~it would give rise to~~ FWM interactions.

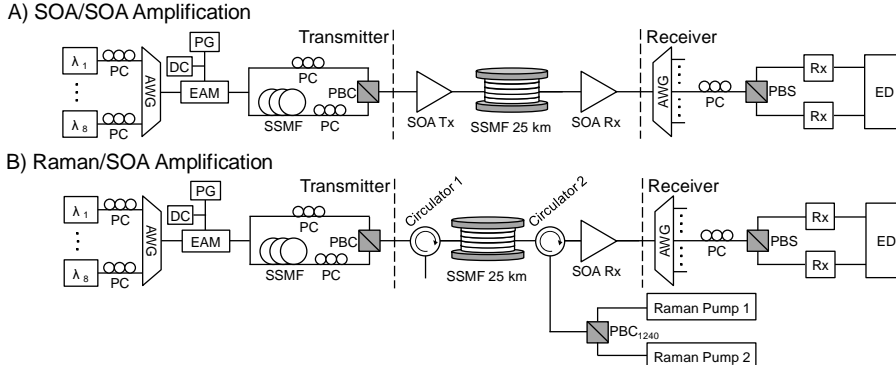

Fig. 7 The experimental setups: SOA/SOA amplification scheme (A) and Raman/SOA amplification scheme (B).

The transmitter in both cases consisted of eight lasers ($\lambda_1 \dots \lambda_8$) operating at wavelengths 1311.5 nm, 1312.9 nm, 1314.3 nm, 1315.7 nm, 1317.1 nm, 1318.4 nm, 1319.7 nm and 1321.1 nm having an output power of 5.0 dBm each. Continuous wavelength (CW) signals after passing through the polarization controllers (PC) were combined in the AWG with the average insertion loss of 4.1 dB and the polarization dependent loss of 1 dB. After the AWG the signals entered the EAM which had a 3dB RF bandwidth of 39 GHz and at the static extinction ratio (ER) of 14.0 dB. The EAM DC bias was set to -2.1 V and the electrical voltage swing used was 2.6 Vpp. All of the optical signals were modulated simultaneously with a 40 Gbit/s PRBS of a length 2^7-1 , which is typically used in the data transmission experiments, coming from a pattern generator (PG). The multiplexed OOK-modulated optical signals were then split into two arms in a 3 dB coupler. The signals were delayed with respect to each other by 55 bits in an SSMF providing partial decorrelation between the orthogonal polarizations and were finally combined in the following PBC, which had the insertion loss < 1 dB and the polarization ER of 26 dB.

The transmission line segment was different for each investigated case. In the case of SOA/SOA amplification scheme (Fig. 7A) the combined DWDM signals were firstly

amplified in the booster SOA Tx, which provided the gain of 13.5 dB and the total optical power at its output was *ca.* 9.0 dBm. The optical signal was then transmitted in the SSMF transmission line. The parameters of the 25.2 km long fibre were: attenuation at 1310 nm 0.325 dB/km, the zero-dispersion wavelength 1316.3 nm and dispersion slope 0.0873 ps/nm²×km. After the transmission line the DWDM signals were amplified in the SOA Rx (gain 12.5 dB, total output optical power 13.0 dBm) and then the entered the receiver.

In case of Raman/SOA amplification scheme (Fig. 7B) the signals were firstly amplified in the distributed Raman amplifier, which used ~~the described earlier~~ transmission line described earlier as the gain medium. Two high power 1240 nm lasers were used as Raman pumps. For each laser the operating temperature was 25 °C and the injection current was 1800 mA resulting in the output power of *ca.* 27 dBm for each laser. Pump signals were combined by the polarization beam combiner optimised for 1240 nm wavelength (PBC₁₂₄₀) which had the insertion loss of 1.3 dB. The pump signals were introduced into the transmission line by ~~the~~ Circulator 2 (insertion loss at 1240 nm 1.0 dB, insertion loss at 1310 nm 0.85 dB) and after passing the transmission line the pump signal was removed by ~~the~~ Circulator 1 (insertion loss at 1240 nm 1.0 dB, insertion loss at 1310 nm 0.85 dB). With this setup the resulting ~~achieved~~ Raman gain was around 14.0 dB. The DWDM signals after the transmission line (and after the Raman amplification in the fibre) were further amplified in the SOA Rx preamplifier (providing total output optical power of 10.7 dBm) and finally entered the receiver.

In the receiver, the wavelength channels were demultiplexed in an AWG which had the average insertion loss of 3.1 dB. Then, each wavelength channel was injected into the PBS to perform the polarization demultiplexing. ~~The Utilised~~ PBS, that was utilised, had the insertion loss < 1 dB and the polarization ER of 26 dB. ~~The d~~Demultiplexed signals were converted into the electrical domain ~~by~~in a photoreceiver (Rx) which consisted of a photodiode

Formatted: Font: Not Italic

integrated with a transimpedance amplifier. The photoreceiver had a 3dB bandwidth of 31 GHz, responsivity of 0.45 A/W at 1310 nm, differential conversion gain of 1600 V/W at 1310 nm and polarization dependence loss (PDL) of 0.2 dB. Finally, the electrical signals were fed into an error detector (ED), where the signals quality in each channel was evaluated.

4 Experimental Results

The left side of the Fig. 8, plotted with blue lines, shows the optical spectra of both polarizations after the booster SOA Tx, and after the preamplifying SOA Rx for SOA/SOA amplification scheme. The power level of the signal injected into the transmission line (after the booster SOA Tx) was *ca.* -4.5 dBm/0.1 nm per channel for each polarization and after the preamplifying SOA Rx the signal reached the average level of -1.0 dBm/0.1 nm per channel. The OSNR dropped from 30 dB after the SOA Tx to 28 dB after the SOA Rx. Moreover, no FWM products were observed.

The right side of the Fig. 8, plotted with purple lines, shows the optical spectra of both polarizations after the PBC, and after the preamplifying SOA Rx for Raman/SOA amplification scheme. The power level of the signal injected into the transmission line (after the PBC) was *ca.* -17.0 dBm/0.1 nm per channel for each polarization. After the amplification in the preamplifying SOA Rx the signal reached the average level of -4.5 dBm/0.1 nm per channel. The OSNR dropped from 45 dB after the PBC to 28 dB after the SOA Rx. Here, as in the previous case, no FWM products were observed.

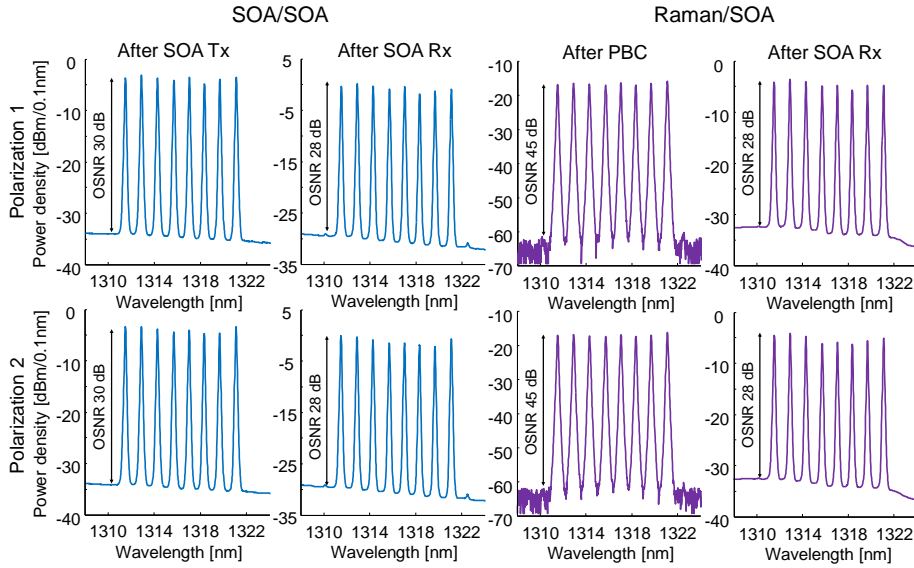

Fig. 8 Optical spectra of the $8 \times 2 \times 40$ Gbit/s 1310 nm DWDM PolMux system in the SOA/SOA (left) and Raman/SOA (right) amplification scheme.

Figure 9 shows the results of the $8 \times 2 \times 40$ Gbit/s BER measurements and captured 40 Gbit/s eye diagrams for channels 1 and 8, for both polarizations, for SOA/SOA (Fig. 9A) and Raman/SOA (Fig. 9B) amplification schemes, obtained in the 25 km transmission experiment. As it can be seen in Fig. 9 all eye diagrams captured in the both experiments show a clear eye opening and indicate excellent operation of the transmission system. During the BER measurements the error-free operation of the system was observed. The average sensitivity at $\text{BER} = 10^{-9}$ was -2.8 dBm and -6.6 dBm for the SOA/SOA and Raman/SOA amplification schemes respectively, resulting in the average sensitivity difference of 3.8 dBm.

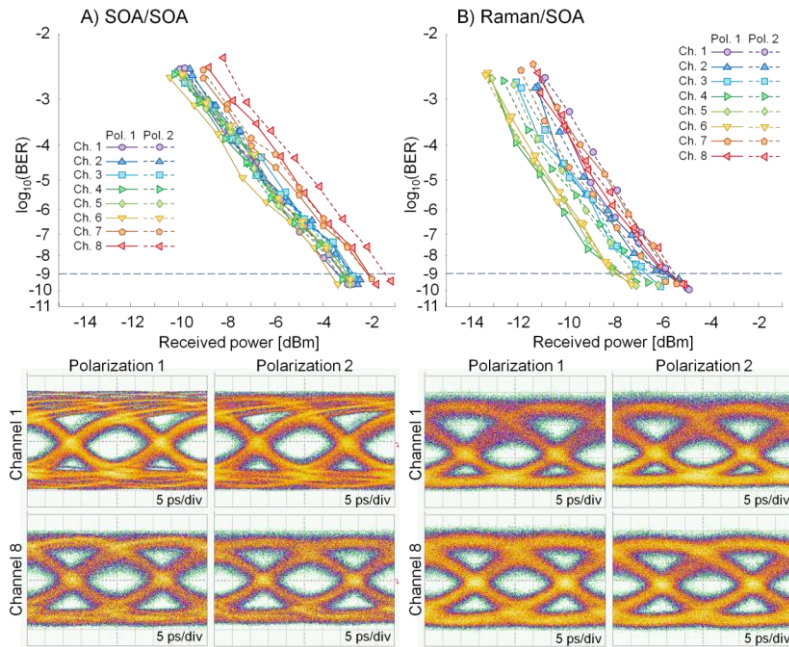

Fig. 9 Results of the $8 \times 2 \times 40$ Gbit/s BER measurements and captured 40 Gbit/s eye diagrams for SOA/SOA amplification scheme (A) and Raman/SOA amplification scheme (B) in the 25 km transmission experiment.

It is seen that the system employing the Raman/SOA amplification scheme performs significantly better than the one utilising SOA/SOA amplification scheme. The average channel sensitivity of the system employing the Raman/SOA amplification scheme is almost 4 dB better than in the case of the SOA/SOA amplification scheme, which is caused by the lower noise figure and lack of patterning effects in the Raman amplifier as well as the SOA gain saturation. This 4 dB difference corresponds to *ca.* 10 km longer transmission in the 1310 nm wavelength domain over the SSMF fibre. Moreover, lack of the SOA booster amplifier leads to lower optical power at the input of the transmission line and thus considerably diminishes the impact of nonlinear effects like FWM. Therefore, the Raman/SOA amplification scheme allows further decrease of the channel spacing, *e.g.* to 100 GHz, leading to more efficient utilisation of the 1310 nm wavelength domain.

5 Conclusions

In this paper, we investigated the utilisation of the SOA and Raman amplifier in a high capacity 1310 nm DWDM transmission system. Through computer simulations, we investigated the impact of different amplification schemes (based on SOA preamplifier and Raman amplifier) on the transmission quality in the 1310 nm window 10×40 Gbit/s DWDM system. Simulations showed that the utilisation of a Raman amplifier in a back-propagation scheme allows much longer error-free transmission (*ca.* 55 km) than the utilisation of the single SOA preamplifier (*ca.* 30 km). We successfully applied Raman amplifier in the 640 Gbit/s 1310 nm DWDM transmission. We compared the performance of the SOA amplifier and Raman amplifier in the high capacity 8×2×40 Gbit/s PolMux DWDM 1310 nm transmission system with the transmission distance of 25 km SSMF. Conducted experiments showed outstanding performance of the system utilising Raman amplifier with the receiver sensitivity improvement of 4 dB in comparison to the one utilising SOA booster amplifier. Such improvement means *ca.* 10 km longer transmission distance for the Raman amplification scheme. Moreover, lower optical power at the fibre input, in case of a Raman amplification, causes no FWM products and therefore allows the decrease of the channel spacing, *e.g.* to 100 GHz, thus leading to more efficient utilisation of the 1310 nm domain. The achieved 4 dB improvement in the receiver sensitivity allows to remove the forward error correction (FEC) from the transmission system and therefore leads to lower latency and power consumption. Achieved results prove that the Raman amplifiers can be successfully applied in the 1310 nm DWDM high capacity transmission systems *e.g.* to extend the reach of the 400G and 1T Ethernet systems.

Acknowledgments

This work was supported by the Polish National Science Centre NCN under the contract UMO-2011/03/D/ST7/02497. The equipment used in the experiments was provided in the framework of the Innovative Economy Program POIG.02.01.00-14-197/09 FOTEH project. The numerical simulations have been conducted in VPI-transmissionMaker™.

References

1. P. Mazurek, H. de Waardt, J.P. Turkiewicz, "Towards 1 Tbit/s SOA-based 1310 nm transmission for local area network/data centre applications," *IET Optoelectron.* **9**, 1-9 (2015).
2. R. Gutiérrez-Castrejón, P. Torres-Ferrera, "Design and technical feasibility of next 400 GbE 40 km PMD based on 16×25 Gbps architecture," *J. Lightwave Technol.* **31**, 2386-2393 (2013).
3. M. Morsy-Osman, M. Chagnon, M. Poulin, S. Lessard, D.V. Plant, " $1\lambda \times 224$ Gb/s 10 km transmission of polarization division multiplexed PAM-4 signals using 1.3 μ m SiP intensity modulator and a direct-detection MIMO-based receiver," *European Conference on Optical Communication (ECOC)*, paper PD.4.4, Cannes, France, September 2014.
4. M. Poulin, C. Latrasse, J.F. Gagne, Y. Painchaud, M. Cyr, C. Paquet, M. Morsy-Osman, M. Chagnon, S. Lessard, D.V. Plant, "107 Gb/s PAM-4 Transmission over 10 km Using a SiP Series Push-Pull Modulator at 1310 nm," *European Conference on Optical Communication (ECOC)*, paper Mo.4.5.3, Cannes, France, September 2014.
5. Innolume GmbH, "Single-mode Laser Diodes", http://www.innolume.com/products/SM_HPLD.htm, (2015).
6. K.C. Reichmann, P.P. Iannone, C. Brinton, J. Nakagawa, T. Cusick, M. Kimber, C. Doerr, L.L. Buhl, M. Cappuzzo, E.Y. Chen, L. Gomez, J. Johnson, A.M. Kanan, J. Lentz, Y.F. Chang, B. Palsdottir, T. Tokle, L. Spiekman, "A symmetric-rate, extended-reach 40 Gb/s CWDM-TDMA PON with downstream and upstream SOA-Raman amplification," *J. Lightwave Technol.* **30**, 479-485 (2012).

7. L.A.M. Saito, P.D. Taveira, P.B. Gaarde, K. De Souza, E.A. De Souza, "Multi-pump discrete Raman amplifier for CWDM system in the O-band," International Telecommunications Symposium, Fortaleza, Ceara, Brazil, September 2006.
8. C. Antony, G. Talli, M. Dalla Santa, B. Murray, S. Hegarty, E. Kehayas, I. Krestnikov, P.D. Townsend, "XG-PON Raman Reach Extender Based on Quantum Dot Lasers," *European Conference on Optical Communication (ECOC)*, paper Tu.3.2.4, Cannes, France, September 2014.
9. B. Zhu, "Entirely passive coexisting 10G-PON and GPON compatible reach extender using Raman amplification," *Opt. Express* **20**, 2290-2296 (2012).
10. L. Lufeng, L. Thinh, "A Raman amplified GPON reach extension system using parameters of a deployed fiber," *Opt. Express* **20**, 26473-26479 (2012).
11. D. Nettet, P. Wright, "Raman extended GPON using 1240 nm semiconductor quantum-dot lasers," Conference on Optical Fiber Communication (OFC), paper OThW6, San Diego, California, United States, March 2010.
12. P. Czyzak, P. Mazurek, J.P. Turkiewicz, "1310 nm Raman amplifier utilizing high-power, quantum-dot pumping lasers," *Opt. Laser Technol.* **64**, 195-203 (2014).
13. P. Mazurek, J.P. Turkiewicz, "Impact of an SOA amplifier on the transmission quality in the 1310nm window high capacity WDM system," *SPIE Proc.* **9228**, 92280Z (2014).

Caption List

Fig. 1 The measured characteristics of the SOA amplifier used in the experiments:

amplifier gain in the function of the wavelength (A), amplifier gain in the function of the output optical power (B), amplified spontaneous emission (ASE) noise density in the function of the wavelength (C), and ASE noise density in the function of the output optical power (D), for different values of the injection current.

Fig. 2 The setup used in the simulations (A), the simulated SOA gain as the function of the wavelength (B), the simulated SOA gain as the function of the output power (C).

Fig. 3 The BER for each channel of the 400 Gbit/s WDM system utilising the SOA preamplifier, as the function of the transmission distance.

Fig. 4 The measured characteristics of the Raman amplifier used in the experiments: amplifier gain in the function of the wavelength for 25 km of SSMF (A) and 38 km of SSMF (B), and amplifier noise figure in the function of the wavelength for 25 km of SSMF (C) and 38 km of SSMF (D), for different values of the pump power.

Fig. 5 The setup used in the simulations (A), the simulated Raman amplifier gain as the function of the wavelength for 40 km of SSMF (B), the simulated Raman amplifier gain as the function of the output power for $\lambda = 1310$ nm and 40 km SSMF (C).

Fig. 6 The BER for each channel of the 400 Gbit/s WDM system utilising the Raman amplifier, as the function of the transmission distance for the pump power of 400 mW (A) and 700 mW (B).

Fig. 7 The experimental setups: SOA/SOA amplification scheme (A) and Raman/SOA amplification scheme (B).

Fig. 8 Optical spectra of the $8 \times 2 \times 40$ Gbit/s 1310 nm DWDM PolMux system in the SOA/SOA (left) and Raman/SOA (right) amplification scheme.

Fig. 9 Results of the $8 \times 2 \times 40$ Gbit/s BER measurements and captured 40 Gbit/s eye diagrams for SOA/SOA amplification scheme (A) and Raman/SOA amplification scheme (B) in the 25 km transmission experiment.

Table 1 Standard SOA module parameters.