

## Report on tyre/road noise

***Citation for published version (APA):***

Blom, R. (2004). *Report on tyre/road noise: generation mechanisms, influence of tyre parameters and experiment on belt resonances*. (DCT rapporten; Vol. 2004.020). Technische Universiteit Eindhoven.

***Document status and date:***

Published: 01/01/2004

***Document Version:***

Publisher's PDF, also known as Version of Record (includes final page, issue and volume numbers)

***Please check the document version of this publication:***

- A submitted manuscript is the version of the article upon submission and before peer-review. There can be important differences between the submitted version and the official published version of record. People interested in the research are advised to contact the author for the final version of the publication, or visit the DOI to the publisher's website.
- The final author version and the galley proof are versions of the publication after peer review.
- The final published version features the final layout of the paper including the volume, issue and page numbers.

[Link to publication](#)

***General rights***

Copyright and moral rights for the publications made accessible in the public portal are retained by the authors and/or other copyright owners and it is a condition of accessing publications that users recognise and abide by the legal requirements associated with these rights.

- Users may download and print one copy of any publication from the public portal for the purpose of private study or research.
- You may not further distribute the material or use it for any profit-making activity or commercial gain
- You may freely distribute the URL identifying the publication in the public portal.

If the publication is distributed under the terms of Article 25fa of the Dutch Copyright Act, indicated by the "Taverne" license above, please follow below link for the End User Agreement:

[www.tue.nl/taverne](http://www.tue.nl/taverne)

***Take down policy***

If you believe that this document breaches copyright please contact us at:

[openaccess@tue.nl](mailto:openaccess@tue.nl)

providing details and we will investigate your claim.

**Report on tyre/road noise**  
Generation mechanisms, influence of tyre  
parameters and experiment on belt resonances

**Ron Blom**

**DCT 2004.20**

Traineeship report

Coaches: N.B. Roozen (TU/e)  
A. Moritz (Vredestein)

Technische Universiteit Eindhoven  
Department Mechanical Engineering  
Dynamics and Control Technology Group

Eindhoven, February, 2004

---

## Summary

Tyre/road noise has never been a big problem for Vredestein in the past. Up until now it has always been possible to achieve about the same performance on this point as the competing tyre manufacturers. But lately Vredestein has had more problems to achieve the same noise levels as other tyre manufacturers. Furthermore the legislation concerning tyre/road noise is about to change. At the moment it is still possible to meet those requirements. However if this legislation becomes even stricter in the future, it may grow to be a problem.

At the moment Vredestein has very little fundamental knowledge about tyre/road noise. To prevent tyre/road noise from becoming a major problem for Vredestein, research into tyre/road noise is started.

Aim of this report is to increase the fundamental knowledge about tyre/road noise. More specifically: which noise generation mechanisms play a role in the generation of tyre/road noise and how can they be influenced by tyre design?

Tyre/road noise generation mechanisms can be divided into two groups:

- Vibrational mechanisms
- Aerodynamical mechanisms

For tyre manufacturers the most important mechanism of the first group is the tread impact mechanism. This mechanism can be influenced by tread pattern design.

For the second group of mechanisms it is much more difficult to indicate which mechanism is most important. Air pumping as well as the air resonance mechanisms seem to be important. These mechanisms can also be strongly influenced by tread pattern design.

Furthermore there is another group of mechanisms which cannot be regarded as pure generation mechanisms, but they do influence the noise emission in a significant way. An important mechanism from this group that can be influenced through tyre design is belt resonance.

This last mechanism is investigated further by experiments because this mechanism is thought to be the cause of the peak in the frequency spectra at 1 kHz. Experiments show that for all tyres there is probably only one cross-sectional mode which is able to radiate sound efficiently. The mode can be influenced through tyre construction, although the influence of extra mass seems to be rather small. The large difference between the normal Bridgestone tyre and the other tyres is believed to be caused by the pre-stress in the nylon overhead of this tyre. This increases the extensional stiffness of the tread, which influences the first cross-sectional mode significantly. This will have to be confirmed through experiments though. At this point it is not possible to tell whether or not the belt resonances are responsible for the above-mentioned peak and further experiments are needed.

---

# Table of Contents

<b>CHAPTER 1 INTRODUCTION.....</b>	<b>1</b>
<b>CHAPTER 2 GENERATION MECHANISMS .....</b>	<b>2</b>
§ 2.1 VIBRATIONAL MECHANISMS.....	3
§ 2.1.1 <i>Running deflection</i> .....	3
§ 2.1.2 <i>Tread impact (300-1500 Hz)</i> .....	3
§ 2.1.3 <i>Texture impact (800-1250 Hz)</i> .....	3
§ 2.1.4 <i>Stick/slip</i> .....	3
§ 2.1.5 <i>Stick/snap (above 1-2 kHz)</i> .....	4
§ 2.2 AERODYNAMICAL MECHANISMS .....	4
§ 2.2.1 <i>Air turbulence (300 Hz)</i> .....	4
§ 2.2.2 <i>Air pumping (&gt; 1000 Hz)</i> .....	4
§ 2.2.3 <i>Pipe resonances (900-2000 Hz)</i> .....	6
§ 2.2.4 <i>Helmholtz resonances (1-2.5 kHz)</i> .....	6
§ 2.3 AMPLIFICATION/ REDUCTION MECHANISMS .....	7
§ 2.3.1 <i>Horn effect</i> .....	7
§ 2.3.2 <i>Belt resonances (600-1300 Hz)</i> .....	7
§ 2.3.3 <i>Torus cavity resonances (230-280 Hz)</i> .....	8
<b>CHAPTER 3 INFLUENCE OF TYRE PARAMETERS ON TYRE/ROAD NOISE.....</b>	<b>9</b>
§ 3.1 TYRE DIMENSIONS .....	9
§ 3.1.1 <i>Width</i> .....	9
§ 3.1.2 <i>Diameter</i> .....	9
§ 3.1.3 <i>Shoulders</i> .....	10
§ 3.2 TYRE STRUCTURE.....	10
§ 3.2.1 <i>Belt</i> .....	10
§ 3.2.2 <i>Changes with respect to torus cavity resonance</i> .....	10
§ 3.3 MATERIAL PROPERTIES .....	11
§ 3.3.1 <i>Elastic modulus and loss tangent</i> .....	11
§ 3.3.2 <i>Rubber hardness</i> .....	11
§ 3.4 TREAD PATTERN.....	11
§ 3.4.1 <i>General layout</i> .....	11
§ 3.4.2 <i>Grooves</i> .....	12
§ 3.4.3 <i>Tread blocks</i> .....	13
<b>CHAPTER 4 MODELLING WORK .....</b>	<b>14</b>
§ 4.1 MODELLING TYRE VIBRATIONS .....	14
§ 4.1.1 <i>Ring model</i> .....	14
§ 4.1.2 <i>Shell models</i> .....	15
§ 4.2 "COMPLETE" MODELS .....	16
§ 4.2.1 <i>Chalmers-model</i> .....	17
§ 4.2.2 <i>The TRIAS model</i> .....	18
<b>CHAPTER 5 EXPERIMENT .....</b>	<b>21</b>
§ 5.1 PRONOUNCED PEAK AT 1 KHZ.....	21
§ 5.2 EXPERIMENT .....	22
§ 5.2.1 <i>Sound radiation</i> .....	22
§ 5.2.2 <i>Experimental set-up</i> .....	23
<b>CHAPTER 6 RESULTS AND DISCUSSION .....</b>	<b>26</b>
§ 6.1 COMPARISON OF MEASUREMENTS .....	26
§ 6.2 PROCESSING THE MEASUREMENTS .....	26
§ 6.3 DISCUSSION.....	32

---

<b>CHAPTER 7 CONCLUSIONS &amp; RECOMMENDATIONS .....</b>	<b>33</b>
§ 7.1 CONCLUSIONS .....	33
§ 7.2 RECOMMENDATIONS .....	33
<b>REFERENCES .....</b>	<b>34</b>
<b>APPENDIX I.....</b>	<b>36</b>
<b>APPENDIX II.....</b>	<b>37</b>
<b>APPENDIX III.....</b>	<b>38</b>
<b>APPENDIX IV.....</b>	<b>39</b>

## Chapter 1 Introduction

Tyre/road noise has never been a big problem for Vredestein in the past. Up until now it has always been possible to achieve about the same performance on this point as the competing tyre manufacturers. But lately Vredestein has had more problems to achieve the same noise levels as other tyre manufacturers. Furthermore the legislation concerning tyre/road noise is about to change. At the moment it is still possible to meet those requirements. However if this legislation becomes even stricter in the future, it may grow to be a problem.

At the moment Vredestein has very little fundamental knowledge about tyre/road noise. To prevent tyre/road noise from becoming a major problem for Vredestein, research into tyre/road noise is started.

Aim of this report is to increase the fundamental knowledge about tyre/road noise. More specifically: which noise generation mechanisms play a role in the generation of tyre/road noise and how can they be influenced by tyre design?

To answer this question the research starts with a literature study. Here the generation mechanisms that play a role in tyre/road noise are identified. From this study it becomes clear that the generation mechanisms can be divided into two groups: vibrational mechanisms and aerodynamical mechanisms. These mechanisms are discussed in chapter 2.

Next the influence of tyre design parameters (e.g. dimensions, tread pattern, tyre structure) is discussed in chapter 3.

Prediction of tyre/road noise requires some prediction or simulation model for the tyre/road noise generation. If such a true model is available, one can play with various modifications to the tyre/road system and study the effects. Therefore some modelling work is discussed in chapter 4.

Apart from the two groups of generation mechanisms mentioned above, there is another group of mechanisms, which cannot be regarded as pure generation mechanisms, but they do influence the noise emission in a significant way. An important mechanism from this group that can be influenced through tyre design is belt resonance. To investigate this mechanism, an experiment is described in the chapters 5 and 6, to examine the influence of extra mass on the vibration properties of the tyre tread. The Vredestein tyre is also compared to two Bridgestone tyres.

In chapter 7 conclusions from the literature study and experiment are discussed and recommendations are made.

## Chapter 2 Generation mechanisms

The generation mechanisms of tyre/road noise have been investigated since the 1970's. All the research has led to a complicated mix of mechanisms, all of which have some influence on the noise generation. In general, there is no disagreement among most experts on the existence of these mechanisms. However, the relative importance of these mechanisms is still disputed.

The most important mechanisms are shown in table 2.1. Also some phenomena closely related to the mechanisms are mentioned in this table. These cannot be regarded as pure generation mechanisms, but they do influence the noise emission in a significant way. In the table they are mentioned under the name "related amplification or reduction mechanisms"

Generation mechanisms		Amplification or reduction mechanisms	
Generation mechanisms	Vibrational	1 Impact mechanisms (mostly radial)	1A Running deflection
			1B Tread impact
			1C Texture impact
	Adhesion mechanisms (mostly tangential)	2A Stick/slip	
		2B Stick/snap	
		3 Air displacement mechanisms	3A Air turbulence
3B Air pumping			
3C Pipe resonances			
3D Helmholtz resonances			
Amplification or reduction mechanisms	4 Horn effect	5 Tyre resonances	5A Belt resonances
			5B Torus cavity resonance
	6 Mechanical impedance effect	The road surface gives more or less reaction to tyre block impacts depending on tyre/road stiffness	
		7 Acoustical impedance effect	7A Porous surfaces affect the source strength
	7B Porous surfaces affect the sound propagation to a far field receiver		

As can be seen in table 2.1 the mechanisms can be divided into two main groups:

1. Mechanisms related to vibrations of the tyre. These mechanisms mostly occur below 1000 Hz.
2. Mechanisms related to aerodynamical phenomena. These mechanisms mostly occur above 1000 Hz.

There is no simple answer to the question of which mechanism is the most important, since their relative contributions may vary for different tyres, roads and operating conditions.

The following sections will describe the mechanisms and the conditions under which they are important. The frequency ranges apply to "normal" tyres and "normal" surfaces.

## § 2.1 Vibrational mechanisms

### § 2.1.1 Running deflection

As a tyre rotates it will be subject to a “running deflection” around its circumference, with the major forces acting at the trailing and leading edges of the contact patch. This momentary “distortion” and following forces in the radial direction will create forced and free vibrations which will propagate along the tread and also into the sidewalls.

### § 2.1.2 Tread impact (300-1500 Hz)

The existence of a tread pattern with separate tread elements in the rolling direction causes a disruption of the smooth radial displacement at the contact patch edges. One could say that the tread elements impact or “hammer” against the road surface, but since the road surface is non-compressible, the tread elements and the tread band will have to absorb the resulting deflection instead of the road. The tread pattern therefore induces vibrations in the tyre. The frequencies which are excited by this mechanism depend on the length of the tread blocks and the vehicle velocity.

$$f = \frac{v}{\lambda} \tag{2.1}$$

where:

- f : Frequency [Hz]
- v : vehicle velocity [m/s]
- λ : block length [m]

Typical frequencies for different velocities and block lengths are shown in table 2.2.

### § 2.1.3 Texture impact (800-1250 Hz)

This mechanism is basically the same as the tread impact mechanism. The difference is that now the surface texture is impacting against the tyre instead of the pattern block against the road. Equation [2.1] is also valid for this mechanism, with λ being the distance between major asperities. Some typical frequencies for this mechanism are shown in table 2.2 also.

λ [mm]		Speed [km/h]				
		30	50	70	90	110
Tread impact						
20-40	Resulting frequency	420-210	700-350	970-490	1250-625	1540-770
30	Resulting frequency	275	465	650	830	1025
Texture impact						
8-20	Resulting frequency	1040-420	1740-700	2430-970	3125-1250	3825-1540
14	Resulting frequency	600	990	1390	1790	2180

### § 2.1.4 Stick/slip

When tread elements pass through the contact patch they accumulate a potential energy, until the forces exceed the friction forces. At this moment the block then suddenly slips back to a position at which the friction forces are large enough to keep the block in place. (see figure 2.1). This process is repeated many times per passage through the contact patch.



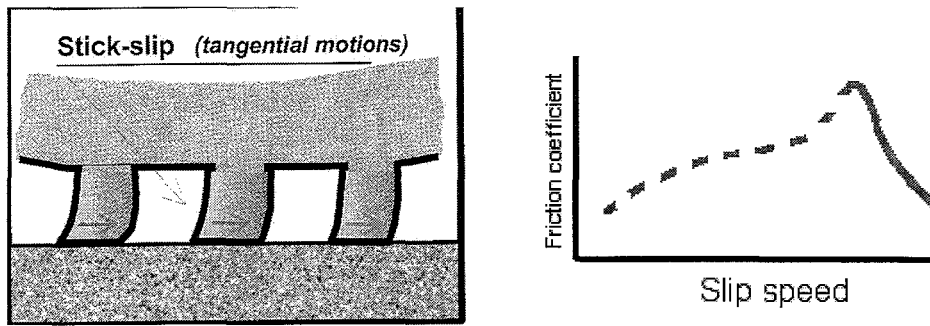

Figure 2.1: Stick slip Left: when tread block deformation gets too large, the blocks slip back Right: friction coefficient against slip speed

This phenomenon only occurs when materials exhibit reduced friction with an increase in slip speed (see solid line in figure 2.1). Stick/slip as a generation mechanism is considered to be very important in situations where great tangential forces are applied to the tyre, such as during acceleration, braking or cornering. During free rolling or driving at constant speed this mechanism is considered to be much less important.

### § 2.1.5 Stick/snap (above 1-2 kHz)

This mechanism occurs when a tyre becomes “sticky” and the road surface is very clean. For example a “winter” tyre at high temperature. The pattern blocks stick to the road surface and some force is needed to break the adhesion. Before the rubber releases from the surface the rubber will be stretched a little. When the block finally is released there will be some vibration in the rubber element to get back to its “rest” position. The adhesion stick/snap mechanism is not considered to be very important for traffic noise, because the road surface is usually covered with a thin layer of dirt. The problem is however important for tyre tests on very clean drums in laboratories.

## § 2.2 Aerodynamical mechanisms

### § 2.2.1 Air turbulence (300 Hz)

The air around the tyre is put into motion by the rotation of the tyre. The noise which is generated by this mechanism only constitutes a significant contribution to tyre/road noise at speeds much higher than normal highway speeds. [Hayden, 1971]. This means the mechanism is not important for the tyre road noise during speeds normally driven in traffic.

### § 2.2.2 Air pumping (> 1000 Hz)

When a tyre rolls a volume of air is enclosed in the contact patch within the cavities and pores constituted by the tread pattern grooves and surface texture. Air is compressed and pressed away at the front of the contact patch and expanded and sucked into the cavities at the rear. Even within the contact patch there will be significant air displacements. The variations of surface texture and tread pattern grooves, the latter of which will be rapidly squeezed, produce a variation of the air flow in time. This generates vibrations in the surrounding air and therefore constitutes a source of sound, characterised by the volume change per unit of time.

Monopole theory has long been used to model air pumped from the squeezed cavities [Hayden, 1971]. This theory applies the Euler equations to a vibrating point source

modelled as a small spherical emitter with radius  $R$ , undergoing *small oscillations*, much smaller than radius  $R$ . The volume of the emitter is:

$$V = 4/3 \pi \cdot R^3 \tag{2.2}$$

The resulting volume changes are then:

$$V' = 4\pi \cdot R^2 \cdot R' \tag{2.3}$$

Where:

- $V'$  : volume changes (time derivative of volume) [ $m^3/s$ ]
- $R'$  : time derivative of radius  $R$  [ $m/s$ ]

These volume changes cause spherically symmetric pressure waves to propagate out from the source decaying as  $1/r$ . The sound pressure  $p$  radiated from a monopole into free space is related to the second derivative of the volume pumped  $V''$  as follows.

$$p = \frac{\rho V''}{4\pi r} \tag{2.4}$$

Where:

- $\rho$  : the density of air [ $kg/m^3$ ]
- $r$  : the source-receiver distance [ $m$ ]

According to [Gagen, 1999] this theory cannot be applied to the squeezed cavities in tyres. The pressure and density changes are too large to be modelled by the small-amplitude acoustic monopole theory (which assumes *small oscillations*). The high accelerations and velocities of walls of a groove of a tyre can violate the assumptions underlying this approach. The groove volume changes can easily exceed 10 %. Gagen claims experimental support for this by results in [Ejsmont et al, 1984] which show that there is a non-linear dependence of emitted sound intensities upon groove width, which is a clear violation of the simple monopole theory. (see table 2.3)

Table 2.3 Effect of changes in lateral groove width				
Change	Effect			
Change in lateral groove width	A-weighted SPL	Level of tread impact fundamental frequency (<1kHz)	Level of "air resonance" frequencies (1-4 kHz)	Level of the highest frequencies (4-16 kHz)
	2 → 9 mm	↑	↑	↑
	9 → 12 mm	↓	↓	●

Gagen thus has derived a "squeezed acoustic wave equation". His starting point are the same Euler equations for fluid flow as used in the monopole theory, together with moving boundary conditions specifying a cavity under compression.

The assumption that the velocity of the expelled jet causes turbulence to generate sound waves, suggests that the sound intensity will depend on the ratio  $L/d$  (groove length/groove width), or the geometry of the cavity. This is in accordance with observations that both thin width and large width grooves emit less sound than medium width grooves (Table 2.3). Evidently, for large grooves  $L/d$  and velocities are small so no sound from air jets is expected. Medium width grooves have  $L > d > 0$  giving a ratio  $L/d$  large enough to give significant sound emission. Finally, thin width grooves with  $d \approx 0$  have very little air in them so the initial mass  $m_0 \approx 0$ , meaning that the kinetic energy of the expelled jet is never significant and little sound is expected.

This theory seems to be the most credible and appropriate so far, but needs further experimental testing and validation.

Air pumping seems to be an important source of sound above 1000 Hz. Especially on dense surfaces. On porous surfaces air pumping is less important because the air can escape from cavities more easily.

**§ 2.2.3 Pipe resonances (900-2000 Hz)**

In the contact patch pipes can be formed between the tyre tread pattern and the road surface. These pipes can either have both ends open or have just one open end. From basic acoustics it is known that the resonance frequencies for these pipes are:

Both ends open ( $\lambda/2$ -resonator):

$$f_n = \frac{n \cdot c}{2 \cdot (L + 0.8 \cdot d)} \tag{2.5}$$

- c : speed of sound [m/s]
- n : integer
- d : pipe diameter [m]
- L : pipe length [m]

One end open ( $\lambda/4$ -resonator):

$$f_n = \frac{(n - 1/2) \cdot c}{2 \cdot (L + 0.8 \cdot d)} \tag{2.6}$$

These pipe resonances then amplify air vibrations caused by for example the “air pumping” mechanism.

Just like air pumping the pipe resonances are more important in dense surfaces than on porous surfaces.

**§ 2.2.4 Helmholtz resonances (1-2.5 kHz)**

A Helmholtz resonance occurs as an interaction in a simple mass-spring system. Applied to tyre noise generation, the volume of the cavity leaving contact with the road surface acts as a spring, and the air present between the tread and the road acts as a mass. (See figure 2.2). As the cavity moves out of the contact patch, a mass-spring system is suddenly created at the moment when the

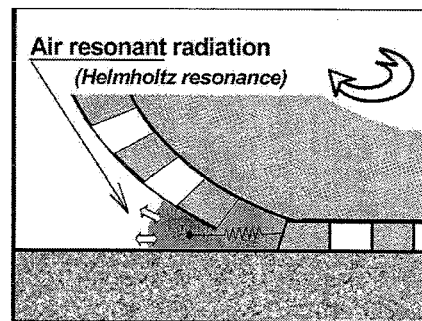

Figure 2.2 Helmholtz resonator

cavity opens to the air behind the tyre. Then, along with the cavity moving further away from the trailing edge, the volume and thus the mass of the air immediately outside the cavity will increase. Since the mass, spring and damping constants determine the resonance frequency, this frequency changes during the cavity movement; at the same time the resonance amplitude decreases. It means that there is a “tone burst” associated with each cavity leaving the contact patch, starting at a high amplitude at a medium frequency and fading-off at a higher frequency.

**§ 2.3 Amplification/ reduction mechanisms**

Besides the generation mechanism discussed in §2.1 and §2.2 there are some other phenomena which have an important influence on tyre/road noise. These mechanisms cannot be regarded as generation mechanisms though. The three most important of these mechanisms are discussed in the following sections.

**§ 2.3.1 Horn effect**

Close to the leading and trailing edges of the tyre footprint, the tyre and the road surface form a structure with a narrow “throat” at the edges, which widens more and more the further out from the edges one moves. This geometry provides a better match between the impedance at the “throat” (where a major part of the noise is generated) and the ambient acoustical impedance. (See figure 2.3).

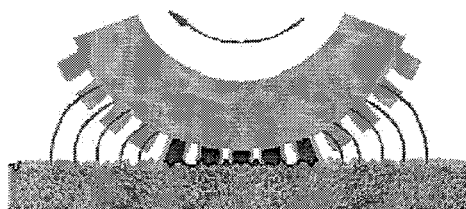

Figure 2.3 Horn effect

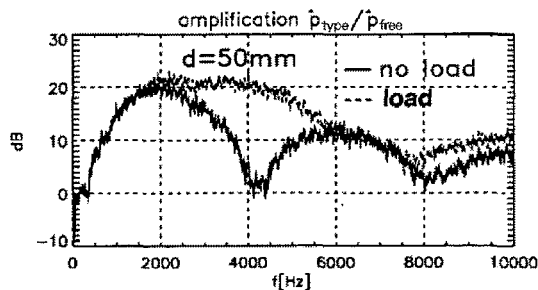

Figure 2.4 Amplification due to the horn effect. *d* is the distance between the source and the wheel axle. *p* is the sound pressure.

[Graf et al., 1999] determines the amplification due to the horn effect. (see figure 2.4). The amplification is determined relative to a situation without the tyre in place. As can be seen from figure 2.4, amplifications due to the horn effect can reach up to 20 dB.

**§ 2.3.2 Belt resonances (600-1300 Hz)**

The deformation of the tyre tread near the contact patch leads to radial and tangential stress discontinuities which induce vibrational modes in the carcass and the belt. The flexural waves propagate from the contact patch in both directions around the tyre, merge and create standing waves. According to [Kim & Bolton, 2001] there are two types of waves: “slow” (60-80 m/s) and “fast” (180 m/s). (See figure 2.5) The fast modes are considered to be efficient radiators.

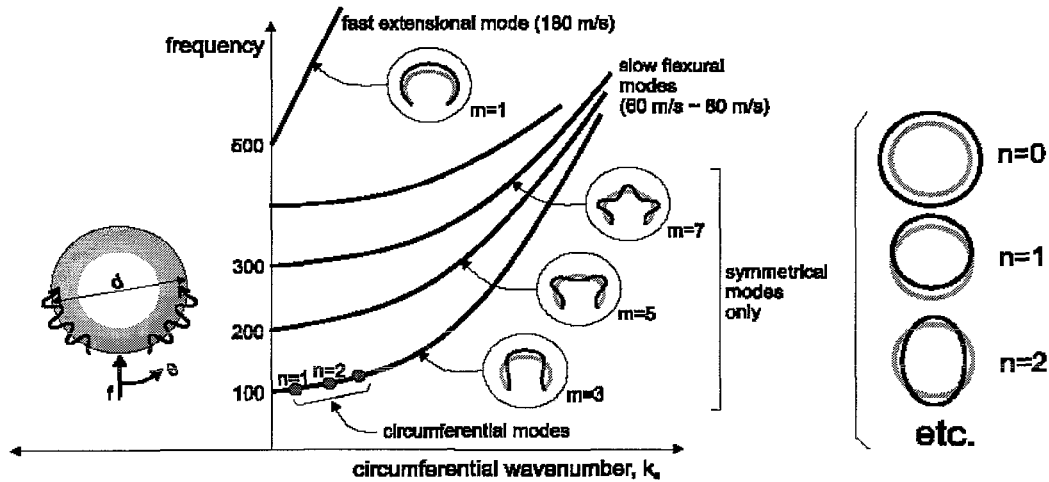

Figure 2.5 Typical tyre dispersion relations [Kim & Bolton 2001]

### § 2.3.3 Torus cavity resonances (230-280 Hz)

The air column in the tyre cavity can resonate at a certain frequency. The frequency of the cavity resonance is defined only by the tyre and rim size and the speed of sound in the medium that inflates the tyre. A simplified equation for the cavity resonance frequency is:

$$f = \frac{c}{l} = \frac{2 \cdot n \cdot c}{\pi \cdot (D + d)} [Hz] \tag{2.7}$$

- c : speed of sound in the gas inflating the tyre [m/s]
- l : length of the cavity [m]
- D : outer diameter of the cavity [m]
- d : inner diameter of the cavity [m]
- n : integer

Typical frequencies for passenger car tyres are in a range of 230-280 Hz (n=1), depending on the tyre size. This means this resonance is more important for interior noise than for exterior noise.

## Chapter 3 Influence of tyre parameters on tyre/road noise

In this chapter the influence of tyre parameters on the tyre/road noise is discussed. If possible quantitative results of changing parameters are mentioned. If this is not possible design guidelines are given to minimize the influence of that parameter on tyre/road noise.

### § 3.1 Tyre dimensions

It is difficult to determine the influence of tyre dimensions on tyre road noise. This is because it is impossible to change one parameter while keeping the other ones constant. For example, while changing the tyre width and keeping the rim diameter and outer diameter constant, the aspect ratio will change. Nevertheless the general influence of tyre dimensions on tyre/road noise is discussed in the next sections.

#### § 3.1.1 Width

One would expect wider tyres to make more noise for several reasons. First of all a wider tyre means more tread block impacts or texture impacts per time unit. Secondly a wider tyre means that more air has to be displaced within the tyre/road interface. And finally the horn effect is more effective for wider tyres than for narrow ones. This effect of width on tyre noise is supported by measurements [Sandberg & Ejsmont, 2002, p210-211].

The increase of noise with width is around 0.4 dB per 10 mm. This seems to be valid only for tyre sizes with widths up to 200 mm. For wider tyres the influence becomes lower and approaches zero for truck tyres.

#### § 3.1.2 Diameter

The relation between tyre diameter and tyre/road noise is less clear. The tyre diameter has opposing effects on air displacement mechanisms and tread and texture impact mechanisms. Air displacement mechanisms are more efficiently amplified by the horn effect if the opening of the horn is less rapid. This means that there is a positive relation between tyre diameter and noise coming from air displacement mechanisms. On the other hand the larger diameter provides a lower attack angle (see figure 3.1)

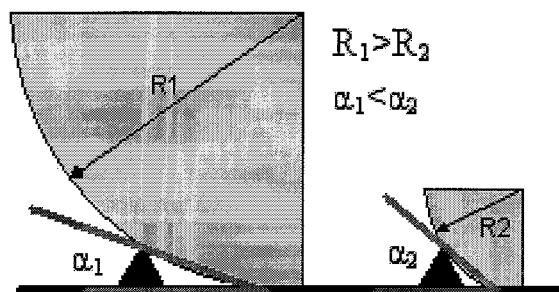

Figure 3.1 Attack angle

which means a gradual displacement change when the rubber and road surface meet. Also the change from first impact to the maximum penetration takes more time (assuming equal vehicle velocity). This is also supported by experiments [Sandberg & Ejsmont, 2002, p211-212] where there is no clear relationship between diameter and tyre/road noise.

§ 3.1.3 Shoulders

The study of [Graf et al, 1999] shows that rounding the shoulders lowers the amplification by the horn effect in the range around 1000 Hz. They report a difference of 5 dB around 1kHz between a sharply cut cylinder and one with “rounded” shoulders.

(see figure 3.2)

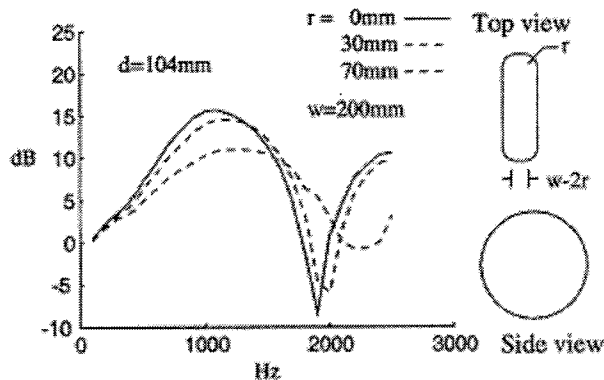

Figure 3.2 Amplification by a solid cylinder with rounded edges of different radii

§ 3.2 Tyre structure

§ 3.2.1 Belt

Increasing the belt stiffness decreases the radial driving point mobility of the tyre and the vibration levels on the tyre. This way tyre noise generation is reduced. This has been confirmed by several experiments. See for example [Sandberg & Ejsmont, 2002, p. 432]. According to [Kropp et al., 1998] the increase in stiffness has to be accompanied by an increase of mass per square meter of the belt. This is because an increase in belt stiffness reduces the radial velocity on the tyre, but at the same time increases the radiation efficiency. Keeping the ratio between mass and bending stiffness constant will lead to a decrease in the mobility of the belt, but will not change the wave numbers on the belt.

In another experiment [Iwao & Yamazaki, 1996] an extra mass (rubber ring) is placed along the centreline of the tread on the inside of the tyre circumference. This reduces tyre noise in the frequency range from 800 to 1100 Hz by some 5 dB.

Increased damping of the belt has also been investigated by placing an “absorptive layer” between the “normal” two steel belts. This resulted in a 3 dB(A) noise reduction. [Bschorr, 1985]

§ 3.2.2 Changes with respect to torus cavity resonance

Fitting an absorptive material on the rim inside the tyre cavity reduces the internal SPL. [Bschorr, 1985] obtains a reduction of the internal tyre SPL from 140 to 130 dB. Outside the tyre the reduction is still 0.8 dB.

Gluing an absorptive material to the inner side of the tyre is reported to almost totally eliminate the torus resonance. [Haverkamp, 1999]. The effect on the overall SPL was not reported. Another approach is used in [Yamauchi & Akiyoshi, 2002]. In this study two extra parts are fitted symmetrically on the rim inside the cavity to make the rim oval, because of this the cross section of the acoustic cavity changes while the tyre rotates. This suppresses the resonance. They report a change of 6 dB(A) in the region

of the torus cavity resonance, determined by experiment. The effect on the overall SPL is not reported.

### **§ 3.3 Material properties**

#### **§ 3.3.1 Elastic modulus and loss tangent**

One of the most comprehensive experiments establishing relations between tyre noise and material properties of tyres is [Muthukrishnan, 1990]. According to his experiments tyres with a low elastic modulus for the rubber in the tread produce the lowest noise levels. The reason for this is that there are less vibrations in the tyre tread because of the softer impact on the road surface.

Some other conclusions concerning material properties from this experiment:

- Tread elastic modulus has a much larger influence on exterior tyre noise level than sidewall elastic modulus.
- The loss tangent of either tread or sidewall has the least effect on tyre noise level.

#### **§ 3.3.2 Rubber hardness**

Intuitively a low rubber hardness seems favourable with respect to low noise tyre design. The impact of soft tread blocks against the surface leads to less vibrations than the impact of hard blocks. If this is true one would expect a lower SPL at frequencies corresponding to the tread impact frequencies. Experiments [Sandberg & Ejsmont, 2002 p219], however show a decrease of the SPL for frequencies normally connected with air-displacement mechanisms. No satisfying explanation for this has been found up until now. Although the noise reduction does not occur in the expected frequency range, softer tyres are indeed quieter than hard tyres.

The fact that softer rubber reduces tyre/road noise is confirmed by a parameter study carried out by [Wullens & Kropp, 2001] using the Kropp-model, at least for the vibration generated noise. For air pumping noise the influence of contact stiffness seems less clear: at lower frequencies a higher contact stiffness leads to less noise, while at higher frequencies a higher contact stiffness leads to more noise. The model used in this study did not include a tread pattern.

### **§ 3.4 Tread pattern**

The tread pattern plays an important role in the generation of sound. For example simply cutting three longitudinal grooves in a slick tyre increases tyre/road noise by 3.5 dB(A). [Saemann & Schmidt, 2002]. Tread pattern influences almost all generation mechanisms mentioned in chapter 2. When designing the tread pattern a lot of other parameters besides tyre/road noise have to be considered and because of this the tread pattern is always a compromise. The next sections give basic requirements for tread pattern design in order to reduce tyre/road noise as much as possible.

#### **§ 3.4.1 General layout**

The shape or contour of the tyre/road footprint at the leading and trailing edges is very important for noise generation. The shape of elements forming the tread pattern of the tyre should not coincide with the contour of the tyre footprint at the leading or trailing edges. (see figure 3.3)

Instead they must cross the contours at a relatively high angle of at least about 45°. If the shape of grooves or blocks does coincide with the footprint contour, the impact at



the leading edge or the release at the trailing edge is abrupt and coherent over a large part of the tyre width. Qualitative results of changes in tread patterns are shown in [Ejsmont et al., 1984] and [Sandberg & Ejsmont, 2002, p 230-231].

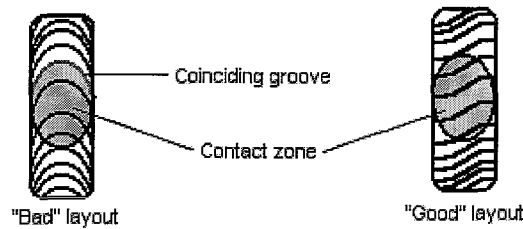

Figure 3.3 "Bad" and "good" general layout

### § 3.4.2 Grooves

For tread pattern grooves everything that improves the ventilation is favourable. In order to reduce air pressure changes in the grooves passing the tyre/road contact area it is necessary to provide enough air channels that help equalise the pressure between

grooves and the atmosphere around the tyre. A tread pattern having closed "air pockets" should be avoided at all times. In the 1970's there a retreaded truck tyre in the US with pockets in its tread. It was so noisy that it received the nickname "Singing Sam".

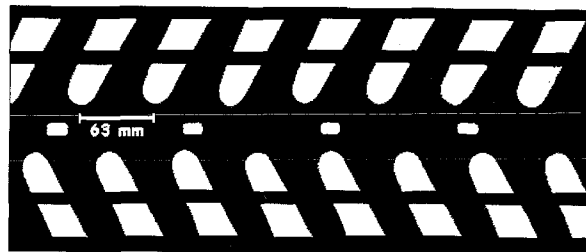

Figure 3.4 Footprint of the "Singing Sam" [Sandberg & Ejsmont, 2002]

Any grooves in a lateral or lateral-diagonal direction such as to at least partly coincide with the outline of the footprint (ignoring the "rule" in §3.4.1) should be narrow. If they are wide, there will potentially be a relatively large step that needs to be bridged between blocks, and a large step means a large radial tangential displacement.

Longitudinal grooves that are not well ventilated to the sides can be acoustically choked by placing a sort of "groove-fence" in the groove. (see figure 3.5).

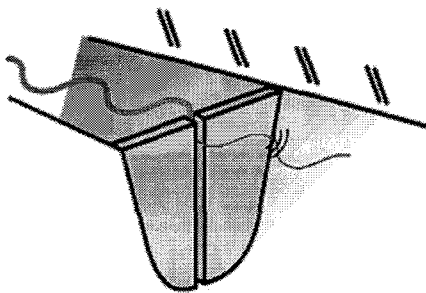

Figure 3.5 Bridgestone groove fence (www.bridgestone-eu.com)

Furthermore the pipe resonance of the longitudinal groove should not coincide with the pronounced peak in the frequency spectrum at 1 kHz. For longitudinal grooves (both ends open) the length at which resonances appear around this frequency is about 175 mm. This is close to the length of the contact patch. Because the length of the contact patch cannot easily be changed, another way of influencing this resonance frequency is changing the length of the pipe by making the grooves sinusoidal or zigzag instead of straight.

For grooves with one end open the critical length is about 90 mm. Unfortunately this is sometimes close to the length of lateral grooves.

The use of sipes (the small grooves used in winter tyres) in the tread is favourable. Siping and the resulting fragmentation of tread blocks into lamellae in the tread

pattern will reduce the tread impact mechanism since it will always be a smaller and more flexible block that momentarily touches the road surface than if no sipes were present. At the same time sipes are too narrow and contain too little air to create noise by any of the air displacement mechanisms.

### § 3.4.3 Tread blocks

To avoid noise with an unpleasant tonal character the tread pattern has to be randomised. This means different pitch lengths have to be placed circumferentially around the tyre. This procedure does not lower the overall noise level, it only distributes the sound power over the spectrum in a more suitable way.

There are different ways of randomising the tread pattern, but according to [Ejsmont, 2000] it is usually enough to test about 1000 randomly generated strings to find a very good one. Some other remarks:

- The ratio between the shortest and longest pitch should be at least 1:1.4
- Too many pitches of the same length in a row should be avoided. This would influence the homogeneity of the tyre.
- According to [Ejsmont, 2000] the asynchronous principle –using different layouts for the left and right side- is slightly better than the synchronous. The difference however is very small and not everyone agrees with Ejsmont on this point.

## Chapter 4 Modelling work

Prediction of tyre/road noise requires some prediction or simulation model for the tyre/road noise generation. If such a true model were available, one could play with various modifications to the tyre/road system and study the effects. This would be very useful for both research and design. This model would have to be extremely complicated because of the large number of generation mechanisms and influential factors. Also a complete model must not only cover the tyre but also the road surface and its contact with the tyre. Because of the complexity of a “complete” model, a lot of researchers have focussed on parts of the problem.

In this chapter models focussing on tyre vibrations are discussed first. The complete models are discussed later on.

### § 4.1 Modelling tyre vibrations

The models that are discussed in this section only describe the dynamic behaviour of the tyre. They do not include generation mechanisms and radiation models.

#### § 4.1.1 Ring model

One of the first models for describing tyre vibrations is by [Böhm, 1966], which is also used by [Heckl, 1986]. Böhm suggested treating the tyre as a circular ring:

$$\frac{ES}{a^2} \left( \frac{\partial^2 u}{\partial \varphi^2} + \frac{\partial v}{\partial \varphi} \right) - \frac{B}{a^4} \left( \frac{\partial^3 v}{\partial \varphi^3} + \frac{\partial v}{\partial \varphi} \right) = \rho S \frac{\partial^2 u}{\partial t^2} + k_T u$$

$$\frac{T_0}{a^2} \left( \frac{\partial^2 v}{\partial \varphi^2} + v \right) - \frac{ES}{a^2} \left( \frac{\partial u}{\partial \varphi} + v \right) - \frac{B}{a^4} \left( \frac{\partial^4 v}{\partial \varphi^4} + \frac{\partial^2 v}{\partial \varphi^2} \right) = \rho S \frac{\partial^2 v}{\partial t^2} + k_a v - q$$

[4.1]

where:

- u : tangential displacement [m]
- v : radial displacement [m]
  
- E : Young’s modulus of the tyre material [N/m<sup>2</sup>]
- S : cross-sectional area [m<sup>2</sup>]
- a : radius [m]
- B : bending stiffness [Nm<sup>2</sup>]
- ρ : density of the tyre material [kg/m<sup>3</sup>]
- k<sub>T</sub> : stiffness determined by elastic properties of the sidewalls and air pressure inside the tyre [N/m<sup>2</sup>]
- T<sub>0</sub> : tension [N]
- k<sub>a</sub> : stiffness determined by elastic properties of the sidewalls and air pressure inside the tyre [N/m<sup>2</sup>]
- q : outside (driving) pressure in radial direction [N/m]

This model has some obvious disadvantages. First of all this model can only account for circumferential modes as variations in the axial directions are not allowed. Secondly, it is difficult to determine the right values for the parameters. A tyre consists of more than one material, so one cannot simply use the parameters of one

material. These values will have to be determined by measurement, which makes it difficult to use this model in the design process. According to [Heckl, 1986] this model is valid for frequencies up to 800 Hz.

**§ 4.1.2 Shell models**

One of the first publications in which the tyre is treated as a 3-dimensional object is [Soedel, 1975]. Here the tyre is viewed as an equivalent thin shell. The response of the rolling tyre is formulated by way of a three-dimensional Green function. This function can be formulated by using modal expansion. The modes and eigenfrequencies of the inflated tyre not in road contact may be obtained theoretically or experimentally. This leads subsequently to the general solution for any kind of tyre loading in terms of an integral. The integral may be simplified by expressing the loading on the tyre by its vector resultant. This approximation eliminates the need to obtain the exact load distribution in the tyre contact area. Damping can also be included by introducing a modal damping factor for each natural mode.

This approach can handle frequencies up to 2000 Hz, depending on how well one is able to determine natural frequencies and modes, either theoretically or experimentally.

One advantage of this approach is that once the modes and natural frequencies have been determined, different loading conditions can be applied. This may also make it possible to determine the eigenfrequencies and natural modes with a large FE model containing all material properties, which should still be a relatively fast calculation, while the dynamic response to a certain input is then determined using the shell approximation. This way it is not necessary to determine parameters like the ones used in the ring model. (Bending stiffness, stiffness of the sidewalls)

Of course to be able to determine the eigenfrequencies and natural modes accurately using a FE model, one has to be able to describe the materials used in the tyre well.

In more recent papers [Kim & Bolton, 2001] and [Kim & Bolton, 2003] use shell models to investigate the propagation characteristics of the waves that contribute to the tyre’s dynamic response. Furthermore they investigate the effects of rotation on

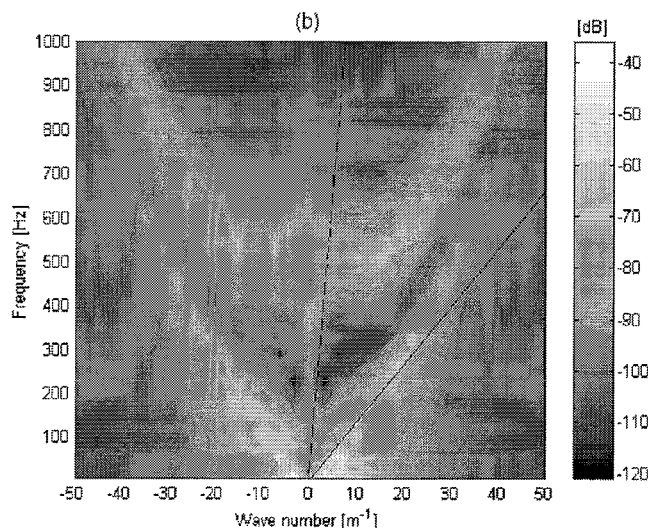

Figure 4.1 Dispersion relations for circular cylindrical shell supported by springs and dampers along the edges of the treadband, dashed line – asymptotic quasi-longitudinal, solid line – equivalent tensioned membrane [Kim & Bolton, 2001]

the dynamics of a tyre.

In [Kim & Bolton, 2001] they use a FE model to model the effect of finite sidewall stiffness and orthotropy resulting from fibre reinforcement of the treadband. This FE model is found to reproduce the major features of tyre dispersion curves: the appearance of tensioned membrane-like flexural wave modes at low frequencies, and the cut on at the tyre’s circumferential ring frequency of a fast mode that is primarily associated with extensional motion of the tread band. (see figure 4.1). For a schematic view of these modes see figure 2.5.

In [Kim & Bolton, 2003] the effects of rotation are examined using a cylindrical shell model. Based on the results with their model, they conclude that at typical rotation speeds it may be possible to use a stationary tyre analysis to predict the dispersion characteristics of a rotating tyre after a simple kinematic compensation. The effect of rotation on the dispersion characteristics can be seen in figure 4.2 a) and b).

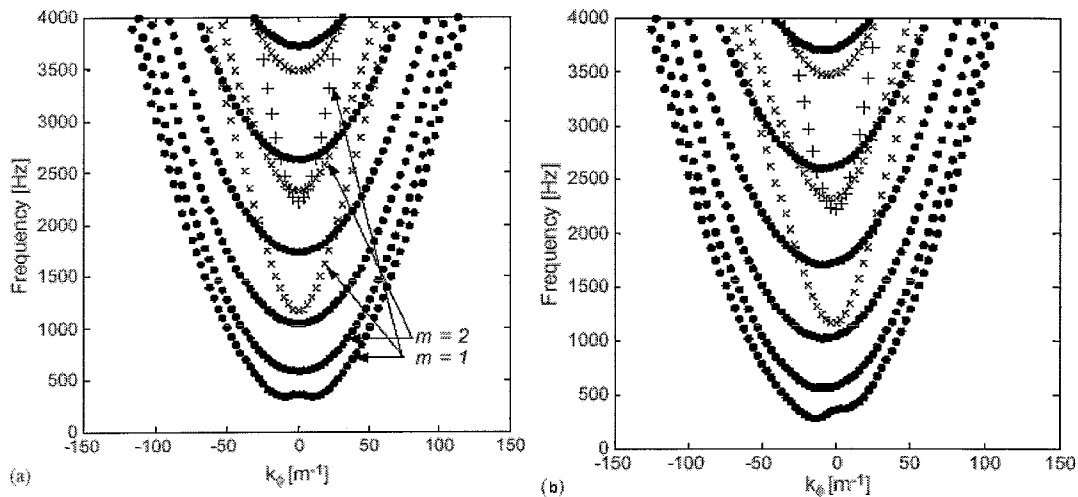

Figure 4.2 Dispersion relations •, flexural wave, x, shear wave, and +, longitudinal wave. (a) Natural frequencies when rotation velocity is 0 (b) natural frequencies in reference coordinates when rotation velocity is 100 rad/s [Kim & Bolton, 2003]

The relation for mapping the stationary forced response onto the rotational response is

$$f = f_s + \frac{k_\phi a}{2\pi} \Omega \quad [4.2]$$

where:

f : rotation compensated tyre natural frequency [Hz]

$f_s$  : stationary tyre natural frequency [Hz]

$k_\phi$  : wave number [m<sup>-1</sup>]

$\Omega$  : tyre rotational velocity [rad/s]

According to Kim and Bolton this is allowed because the rotational stiffness effect is negligible at normal rotation speeds for car tyres (up to 100 rad/s).

### § 4.2 “Complete” models

The vibrational models discussed in the previous section can account for the dynamic behaviour of a tyre, but they do not include the mechanisms generating these vibrations. Nor do they include the aerodynamic noise sources. Two recent models, which try to model the tyre/road noise generation and propagation more or less completely are the Chalmers-model and TRIAS (Tyre Road Interaction Acoustic Simulation). These two models are discussed in the next two sections.

### § 4.2.1 Chalmers-model

First reports on this model are published in 1989 ([Kropp, 1989]). At that time the model is far from complete, but in the past years the model has been improved and parts have been added. The following describes the three main parts of the model as it is at this moment.

#### *Tyre model*

The model basically describes a smooth tyre rolling at constant speed over a rough road surface. The tyre model is based on the elastic field equations modelling a structure consisting of two coupled layers under a static tension. The two layers represent the steel layer and the rubber tread. An elastic bedding supports the layers in all three directions to model the interior pressure of the tyre and contribution of the sidewalls stiffness. Since the contact between the tyre and the road is of non-linear nature the description of the vibrational properties of the tyre is formulated in the time domain. The circumference of the tyre is divided into discrete elements (slices with the width of the tyre), represented by their contact points. A matrix containing Green's functions (i.e. impulse response functions) describes the displacement response in any discrete point due to forces at these points. Main simplification of the model is the omission of the curvature of the real life structure, which leads to deviations at low frequencies (below  $\pm 400$  Hz, the ring frequency).

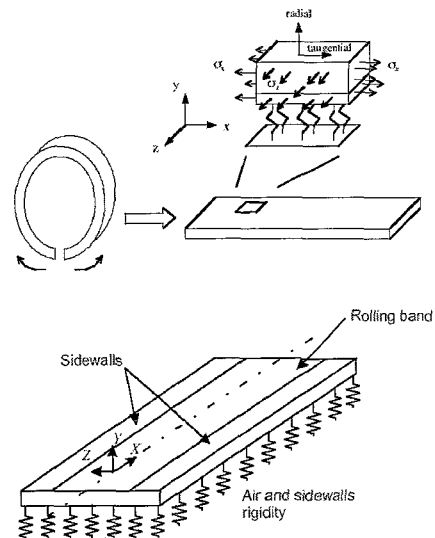

Figure 4.3 Schematic view of the Chalmers-model

However these deviations can be compensated for by for instance frequency dependent material data. For a more detailed description on the tyre model see [Larsson & Kropp, 2002].

#### *Contact model*

The second part is the formulation of the contact between tyre and road. Up until recently this has always been a Winkler bedding, a bedding of uncoupled springs. There are two problems with this approach: 1) How to define the individual spring stiffnesses so they give a realistic description of the tyre tread surface. 2) the roughness of the road influences the contact stiffness.

In the current contact model the coupling between contact points is taken into account. The model calculates the dynamic radial contact forces during rolling, the local deformation at the contact patch due to roughness indenting, and the normal forced vibrations of the tyre structure. The contact problem is solved by classical contact mechanisms using an elastic half-space. The road is assumed rigid and its roughness is obtained by laser measurements. For a more detailed description see [Wullens & Kropp, 2003]. This model does not include adhesion forces, because the forces can only be positive (only compression). The problem of how to define the stiffness of the springs is eliminated, because the use of a tyre model that includes the local stiffness of the tyre makes the Winkler bedding redundant. The local stiffness and the coupling between the contact points can be found from the Green's functions.

The total displacement in any point can then be calculated as a convolution between the contact forces and the Green functions.

The tread pattern can also be included in the model. At this time there have been no publications on this subject according to [Andersson, 2003].

Simply speaking, the model includes the tread pattern by including or excluding contact points in a pattern similar to the geometry of the tread pattern. The Green functions (response of the tyre) do change as the pattern is "carved out" compared to a slick tyre. A paper written by Andersson on how the mobilities change due to simple geometries of tread patterns, is currently under review and will be published in a near future.

Finally the air pumping noise generated by the local deformation of the tread is calculated from volume sources derived from the contact forces

#### *Radiation model*

The last step is to calculate the radiated sound caused by the vibration and deformation of the tyre belt. This means that two main generation mechanisms are included in the model: the tyre vibrations and air pumping due to time variant deformation of the tread by roughness peaks of the road surface. Both mechanisms are amplified by the horn effect. Therefore the influence of the horn, built by the curvature of the tyre and the surface of the road, has to be taken into account as well as the reflection properties of the road surface. This allows for the investigation of the influence of porous road surfaces on noise radiation.

The basic idea is a multi-pole synthesis. Two multi-poles are situated symmetrically on either side of the surface. Thus the boundary conditions of the surface – given in the form of the reflection factor in the normal of the direction of the surface – can easily be satisfied. The key point is that both multi-poles together have to fulfil the boundary condition given on the tyre surface (i.e. calculated velocity in the normal direction of the tyre surface). This way the multiple reflection of sound in the horn is considered.

#### *Ongoing work*

The Chalmers-model is not complete yet. Researchers at Chalmers University (e.g. Patrik Andersson) are still working on the following subjects:

- Adhesion mechanisms
- Stick-slip mechanisms
- Aero-acoustic mechanisms (e.g. Helmholtz resonance)

### **§ 4.2.2 The TRIAS model**

The central component of the TRIAS model (developed by TNO-TPD) is the interaction rolling model, that calculates the vibration pattern of the tyre based on the excitation of the tyre by the roughness of the road texture (height (x,y)) and the modal response of the tyre. The model is based on the work of Kropp, but is extended to excitation over the whole contact area between tyre and road surface (2D). For this purpose a pre-processing module converts measured or synthesized 1D road texture profiles into a 2D texture field. When measured 2D texture data are available this step is unnecessary. The modal response of the tyre is calculated from the mechanical parameters of the tyre using a homogeneous, orthotropic plate-like model. The vibration pattern of the tyre is used to calculate the modal amplitude of displacement and the volume flow for the air pumping model, which is the input to the next units of the model. The vibration model is used for the computation of the sound radiation due

to tyre vibrations. It converts the displacement amplitudes to velocities and subsequently uses a commercially available FBEM-code to convert the velocities to sound levels at specified perception positions. The air-pumping noise model determines the sound radiation due to changes in the volume of the air in the grooves of the tyre tread and in the voids of the road surface. It converts the deformations of the tread relative to the surface texture into an alternating volume velocity that acts as a sound source. The output of this volume source is subsequently amplified by groove resonances and attenuated by damping in the pores of a porous road surface. The sound transmission from the source to a receiver position is computed in two steps; the first step is constituted by the source transmission model that consists of semi-empirical transfer functions for the horn effect, the directivity and the road surface reflection. The second step is incorporated in the situation transmission model and deals with the propagation effects caused by road-side absorption or reflection,

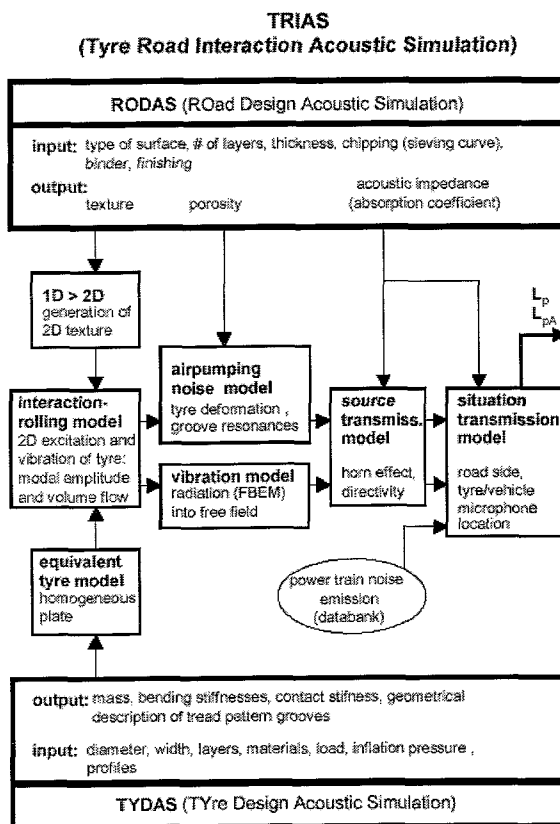

Figure 4.4 Overview of the elements of the complete TRIAS model [de Roo et al. 2001]

may be deduced from basic characteristics of the tyre material and construction (density and elasticity module of layers) using well-known mechanical theory. The module used for these computations is called TYDAS.

*RODAS (ROad Design Acoustic Simulation)*

Within the TRIAS model the road surface is characterised by its texture and, in the case of porous surface, its porosity and acoustic impedance (absorption) [De Roo et al., 1999]. The texture must be described as a 2D texture field, i.e. a texture height as a function of the (x,y) position. These characteristics may be obtained from measurements and transformed into the required format. If they are not available as measured data they may be deduced from the basic characteristics of the road surface

vehicle configuration (number of tyres; shielding by car body) and characteristics of the receiver location.

*TYDAS (TYre Design Acoustic Simulation)*

In the input of the simulation model the tyre is represented by a pre-stressed, homogeneous, cylindrical shell, a bitmap representation of the tread pattern and a geometrical description of the tread pattern grooves. The dynamic properties of the tyre are represented by the equivalent mass, bending stiffness (circumferential and lateral), the deformation stiffness related to the pre-stress level caused by tyre pressure and curvature and the contact stiffness of the rubber tread surface. If these properties cannot be derived directly from measurements or from design models of tyre manufacturers, they



---

material and composition (type of surface, layer thickness, chipping size, binder, finishing) by means of the module RODAS. This module simulates the composition of the surface layer and derives the physical characteristics from this simulation [De Roo & Gerretsen, 2000]. The simulation as well as most measurements characterise the texture as a profile, i.e. a texture height as a function of the distance ( $x$ ) along a line. Therefore the model contains a module that converts the 1D texture profile data into 2D texture field data according to an auto-regressive random process modelling.

#### *Validation*

After validation in [de Roo et al. 2001] it is concluded that the model does not yet show the degree of agreement that is finally aimed for. One of the reasons for the lack of agreement may be that no specially prepared experiments were done. Therefore the quality of the input data is relatively low. Nevertheless the model seems to be able to predict general influence of tyre design on sound emission but is unable to predict the effect of small changes correctly. It is suggested that the balance between the contributions of mechanical vibrations and air pumping might need further study.

## Chapter 5 Experiment

The generation mechanisms have been identified and the influence of the tyre parameters has been described in the previous chapters.

In this chapter experiments are done to get a better insight into one of the possible causes of the pronounced peak in the frequency spectrum at 1 kHz: belt resonances.

### § 5.1 Pronounced peak at 1 kHz

Almost every frequency spectrum of tyre/road noise has a wide peak at about 1 kHz. (See figure 5.1). The centre of this peak can vary between 600-1300Hz.

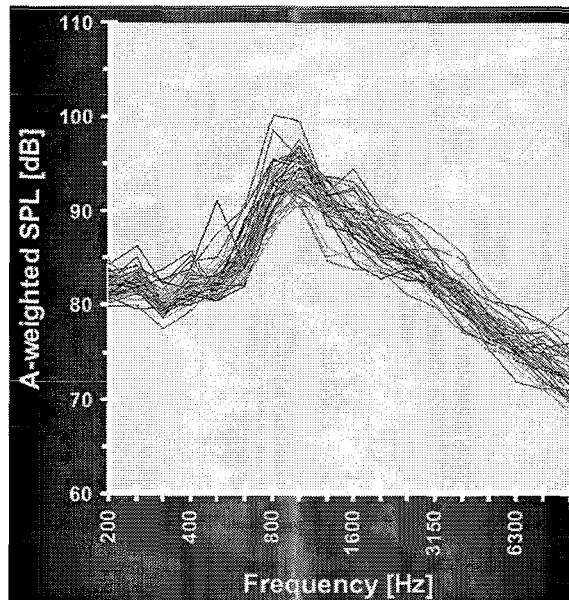

Figure 5.1 Frequency spectra of 50 different car tyres running on a drum with an ISO replica road surface at 90 km/h [Sandberg, 2001]

The peak contributes significantly to the overall noise level. If the peak was to be removed completely, that means if the SPL of the frequencies around 1kHz were to be equal to those outside this range, the overall SPL would be approximately 6 dB(A) lower. This indicates the importance of this peak. So if it is possible to understand what exactly causes this peak, it might be possible to affect it.

The peak may be caused by several generation mechanisms as almost all mechanisms are active around 1000 Hz. (see table 5.1).

Table 5.1 Frequency ranges for generation mechanisms	
Mechanism	Frequency range of importance (Hz)
Tread impact	300-1500
Texture impact	800-1250
Stick/slip	>1000
Stick/snap	>1000 à 2000
Air turbulence	300
“Air pumping”	>1000
Pipe resonances	900-2000
Helmholtz resonances	1000-2500
Horn effect	600-2000 (pass-by measurements)
Belt resonances	600-1300
Air cavity resonance	200-250

However, some of these mechanisms cannot be the (main) cause of the peak for the following reasons:

1. The peak also appears for non-patterned tyres, where the tread impact mechanism does not occur. [figure 3 Sandberg, 2003]
2. The peak also appears on surfaces with a pronounced macro texture. Air can escape from the cavities much easier in these surfaces. This means air pumping, pipe resonances and Helmholtz resonances are much less important. [figure 1 Sandberg, 2003]
3. The peak is independent of speed. This means it cannot be due to the tread or texture impact mechanisms. [figure 7.13 Sandberg & Ejsmont, 2002]

According to [Sandberg & Ejsmont, 2002] belt resonances may play an important role. As mentioned before, the peak has a large influence on the overall SPL and if the belt resonances play such an important role as suggested by [Sandberg & Ejsmont, 2002] knowledge about these resonances can help lowering the peak and by that the overall SPL.

## § 5.2 Experiment

### § 5.2.1 Sound radiation

The generation of sound waves in the air due to flexural waves in a plate is depicted in figure 5.2. For both waves [ 5.1] holds.

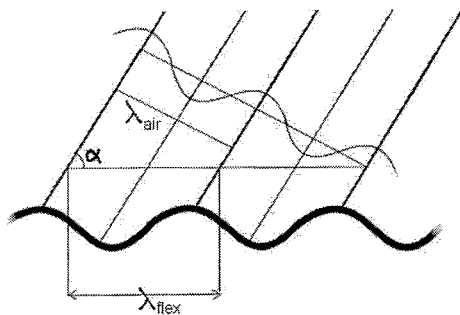

Figure 5.2 Generation of a sound wave

$$\lambda = \frac{v}{f} \tag{5.1}$$

where  $\lambda$  is the wavelength [m],  $v$  is the propagation velocity [m/s] (which is different for different media and also frequency dependent) and  $f$  is the frequency [Hz]. To be able to satisfy [5.1] for both waves the sound wave has to be radiated under a certain angle  $\alpha$ . From figure 5.2 follows:

$$\sin \alpha = \frac{\lambda_{air}}{\lambda_{flex}} \tag{5.2}$$

This means only waves with  $\lambda_{flex} > \lambda_{air}$  can efficiently radiate sound. Or in terms of wave numbers ( $k = \frac{2\pi}{\lambda}$ ):  $k_{flex} < k_{air}$ .

For waves with a shorter wavelength an effect called “hydrodynamic short-circuiting” takes place. This can be interpreted as a sort of pressure equalisation between areas of high and low pressure at a distance less than  $\lambda_{air}/2$ . This means that a mode radiates sound efficiently, if its resonance frequency lies above the line in figure 5.3. So to determine which modes are important for sound radiation, their behaviour in the frequency-wave number domain has to be known. (The different modes are depicted in figure 2.5.)

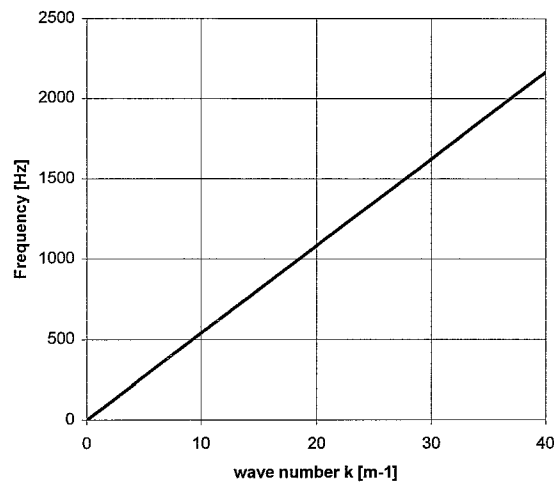

Figure 5.3 Dispersion relation for sound waves in air:  $f = \frac{c_a}{2\pi} k$ , where  $c_a$  the speed of sound in air

After the dispersion characteristics of the original tyre have been determined, extra mass is added on the inside of the tyre to investigate its effect on these characteristics. Furthermore two Bridgestone tyres are measured, one normal tyre and one so-called run-flat tyre. This is done to see if the results are similar for other tyre brands.

### § 5.2.2 Experimental set-up

To perform the measurements a construction is made to mount the tyres on. (see Appendix I) The tyres that are used are a Vredestein Ultrac 235/45 R17 94W, Bridgestone Potenza RE050 225/45 ZR17 91Y and a Bridgestone Potenza RE050A RFT 225/45 R17 91W. The tyre is forced radially at the centre of the treadband by a shaker (Brüel & Kjaer). The force is applied through a screw that is screwed into the treadband. The shaker is mounted in a rubber inner bicycle tube. This way the shaker does not induce vibrations in the set-up (see figure 5.4 and 5.5). A Brüel & Kjaer 8200 force cell is placed between the stinger and the shaker to measure the force input to the tyre.

The radial accelerations are measured at 82 (80 for the Bridgestones, because of the slightly smaller circumference) equally spaced locations around the circumference of the tyre (see Appendix III). A PCB 303A02 accelerometer is used to measure the accelerations. A SigLab model 20-42 is used to generate the input signal (frequency sweep) and gather the output. The input signal from SigLab is amplified with a LDS PA25E power amplifier and supplied to the shaker. The recorded information is then processed using Matlab.

The construction for mounting the tyre on is relatively heavy (around 80 kg). To test whether the construction has to be attached to the floor several measurements were done to compare the vibration levels on the tyre tread to the vibration levels on the rim (See Appendix II&III). These measurements show a difference of at least 20 dB between those two levels. From this it can be concluded that vibrations of the construction do not influence the measurements. In figure 5.6 the results of four measurements are shown. No. 1 is the response of the location on the tyre just next to the excitation point. No. 42 is the location exactly opposite to the excitation point.

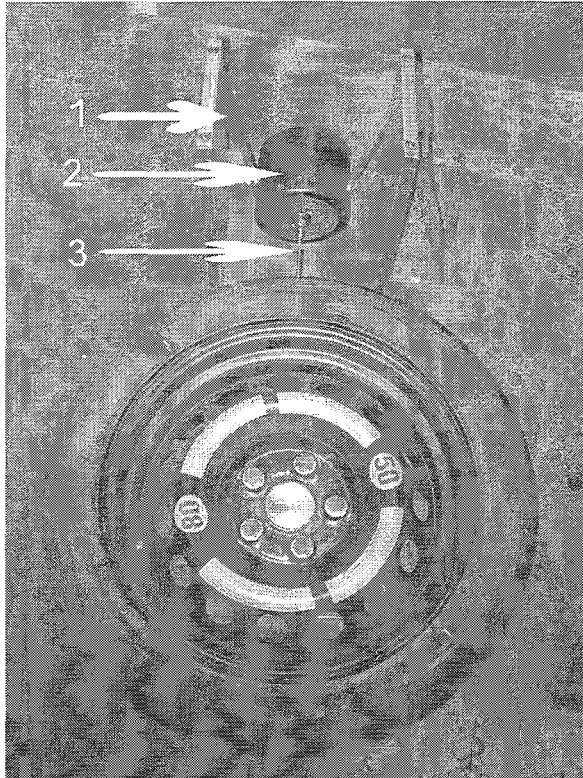

Figure 5.4 a) Photo of the measurement set-up.  
1: Rubber inner tyre; 2: Shaker; 3: See close up 5.4b

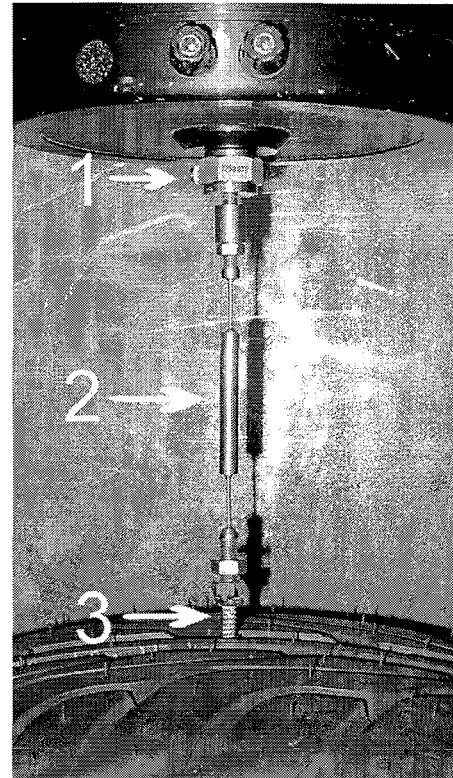

Figure 5.4b) Close-up from 5.4a  
1: Force cell; 2: stinger; 3: Screw

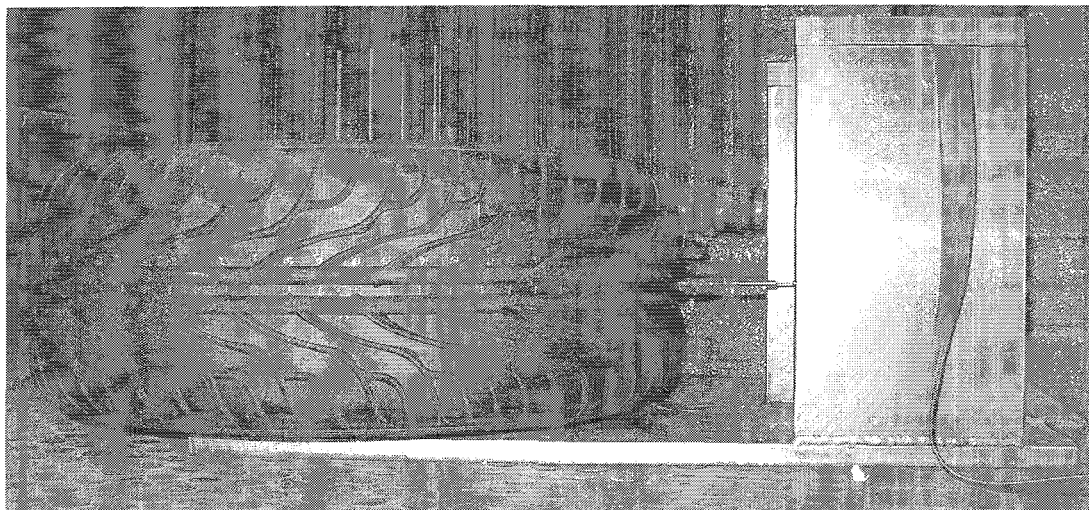

Figure 5.5 Side view of the measurement set-up

The other two are the responses on respectively one quarter en three quarters of the tyre circumference. The responses for points 20 and 63 should look similar as the distance to the excitation point is about the same for these two locations. Below 100 Hz the coherence in the measurements was very bad. This is probably because the force input at these frequencies is too low to generate a substantial response. It can also be seen from this figure that the modes at frequencies above 300 Hz are less clear then the lower ones. This is due to the strong damping in the tyre. Because of this frequencies higher than 1000 Hz are not considered anymore, there is little useful information there anyway.

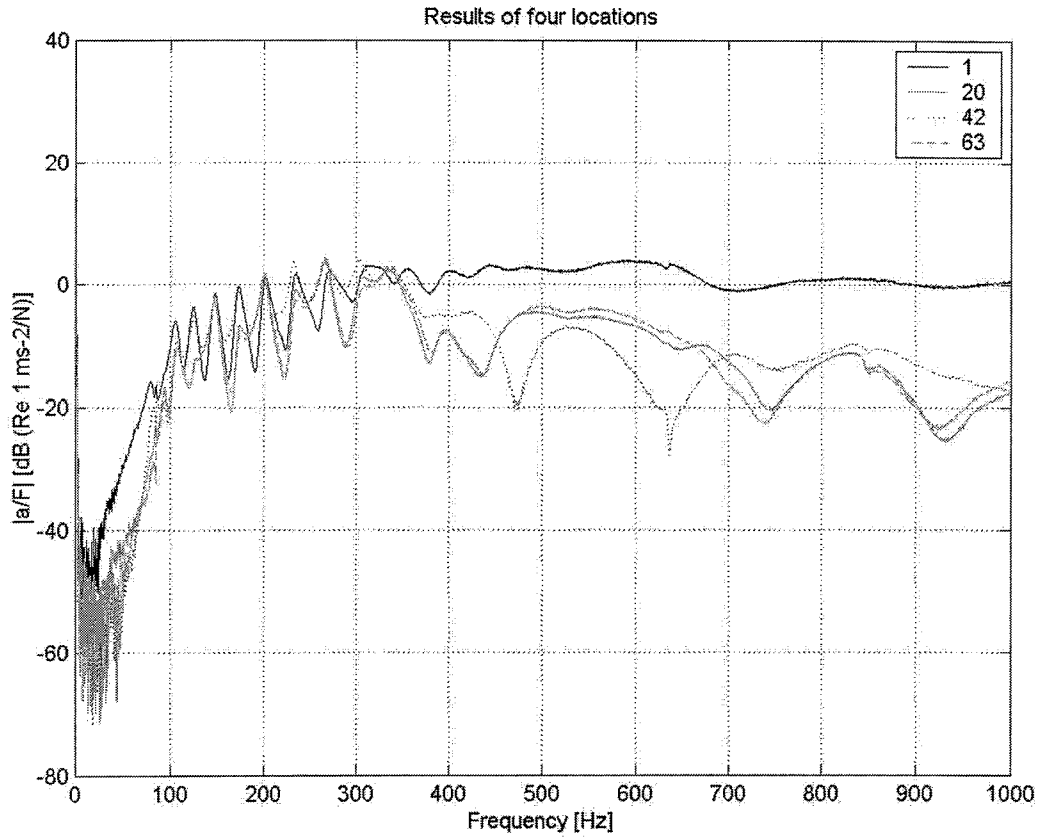

Figure 5.6 Results for four locations around the tyre

After the measurements on the standard tyre are completed a piece of rubber is glued to the inside of this tyre. A sketch of its cross-section is shown in figure 5.7. The piece of rubber weighs about 1 kg/m so a total of 2 kg of rubber is added to the tyre. The mass of the standard tyre is about 10 kg.

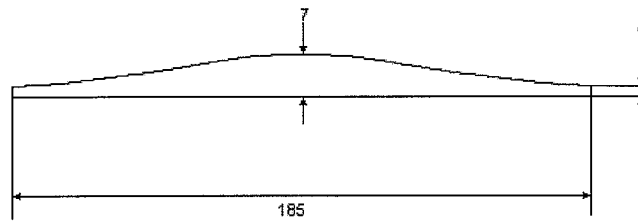

Figure 5.7 Sketch of the cross-section of the extra piece of rubber

## Chapter 6 Results and discussion

In this chapter the results of the measurements on all of the tyres (Vredestein and Bridgestone) are presented and discussed. But first of all the measurements done on the standard Ultrac tyre will be compared to measurements done by other researchers. Although they used other tyres, the order of magnitude of the FRF should still be about the same. Also some characteristics should be present in both measurements.

### § 6.1 Comparison of measurements

In figures 6.1a and 6.1b the point mobility for measurements done by Pietrzyk (Goodyear) and the point mobility for the measurements done on the Vredestein Ultrac. The results have the same order of magnitude: about  $-50$  dB. And except for the bump around 350 Hz the results look similar. The peaks at lower frequencies (100-300 Hz) represent the beam like behaviour of the tyre. The results are not completely the same; the increase of the mobility at 350 Hz in figure 6.1a is not present in figure 6.1b. However one cannot expect the two results to be exactly the same as the measurements were performed on different tyres. Other measurements show roughly the same typical results. See for example [Anderson & Larsson, 2003] and [Matsuoka & Okuma, 2002]. This means that at this point there is no reason to doubt the results of the measurements

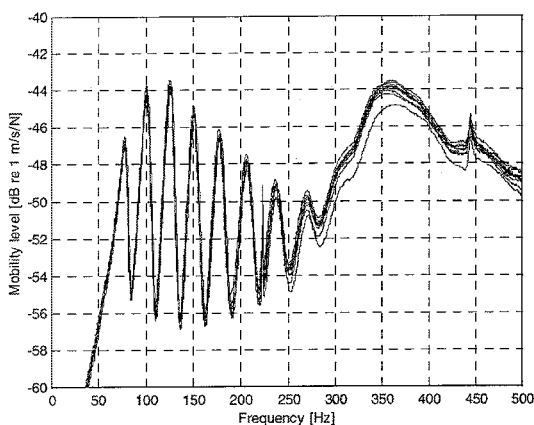

Figure 6.1 a) Measurements done by [Pietrzyk, 2001]

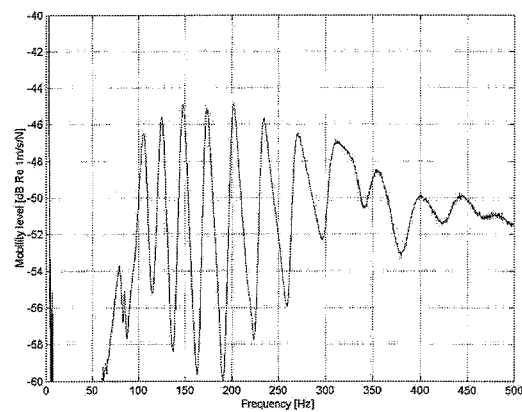

Figure 6.1 b) Measurements done at Vredestein

### § 6.2 Processing the measurements

As mentioned in chapter 5 the FRF was measured at 82 points along the circumference of the tyre. The results of these measurements for both Ultrac tyres (standard and modified) are shown in figures 6.2a and 6.2b. The 82 FRF measurements were stored in a matrix, one column for each FRF. So if one goes through a row from left to right, one can see how all 82 points behave for one particular frequency.

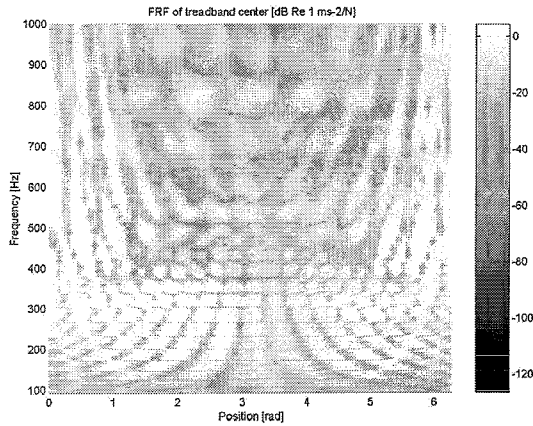

Figure 6.2 a) FRFs of the 82 measurement points of the standard tyre

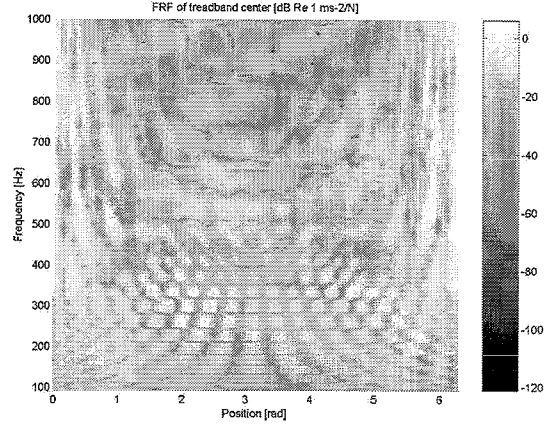

Figure 6.2 b) FRFs of the 82 measurement points of the modified tyre

Next this data is transformed to the frequency-wave number domain by performing a Fourier transformation on each row of the matrix. The results are shown in figures 6.3 to 6.6. These figures do not display values below -30 dB, otherwise the figures would be very unclear. The cross-sectional modes with  $m=1$ ,  $m=3$  and  $m=5$  can easily be

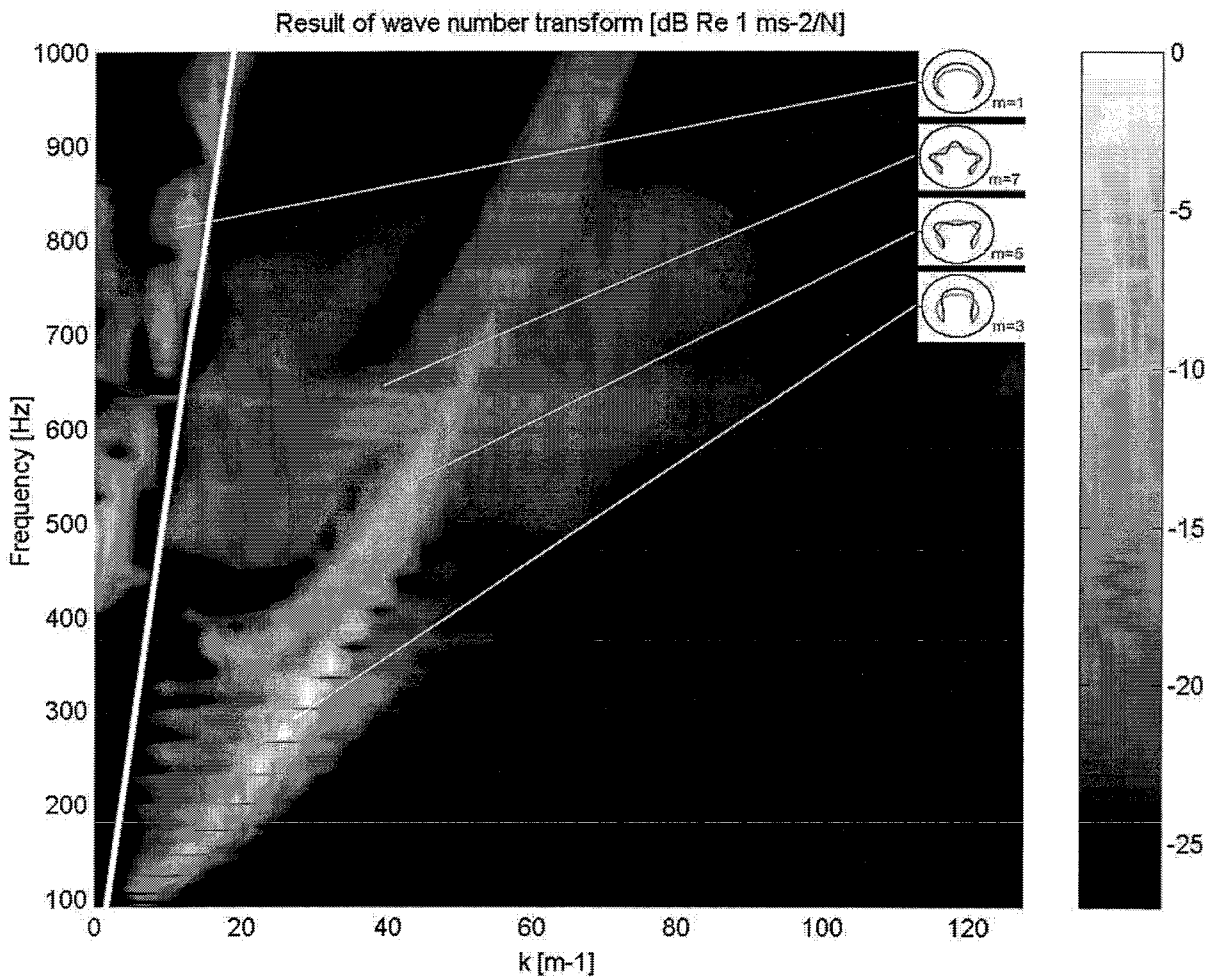
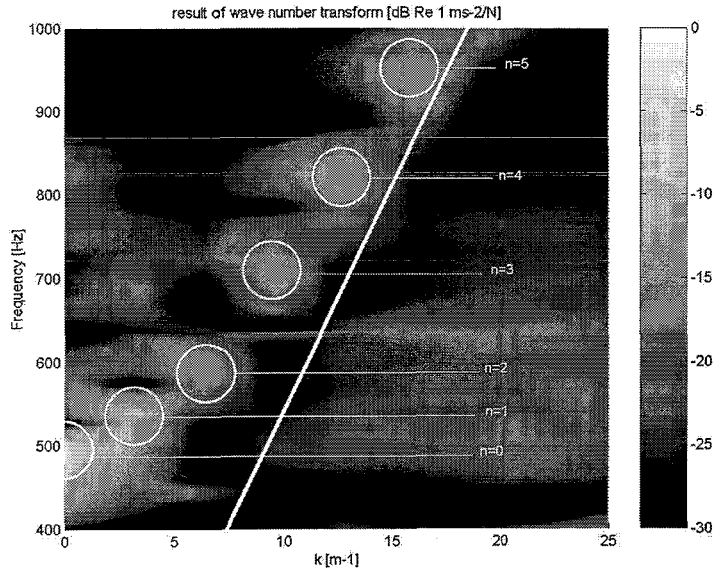

Figure 6.3 Result of the wave number transform for the standard tyre. The thick white line is the dispersion relation of sound waves in air



distinguished in figure 6.4. If one looks a little closer even the mode with  $m=7$  can be seen. This mode is less obvious because of the damping in the tyre material. Only the odd cross-sectional modes are visible because the tyre is excited at the centre of the tread. Because of this the even cross-sectional modes are not excited.

From this figure it can be seen that also for this tyre only the first cross-sectional



mode is able to radiate sound efficiently, even at higher frequencies, as this is the only mode that stays above the white line. Figure 6.5 shows a close up of the first cross-sectional mode from figure 6.4. In this figure it is easy to distinguish the first six circumferential modes. ( $n=0$  to  $n=5$ ). Contrary to the other modes ( $m=3$ ,  $m=5$  and  $m=7$ ) this mode has a significant component at  $k=0$ . That the other modes do not have a significant component at lower wave numbers means that these cross-sectional modes probably do not radiate much sound.

Figure 6.4 Close-up of the first cross-sectional mode from figure 6.3

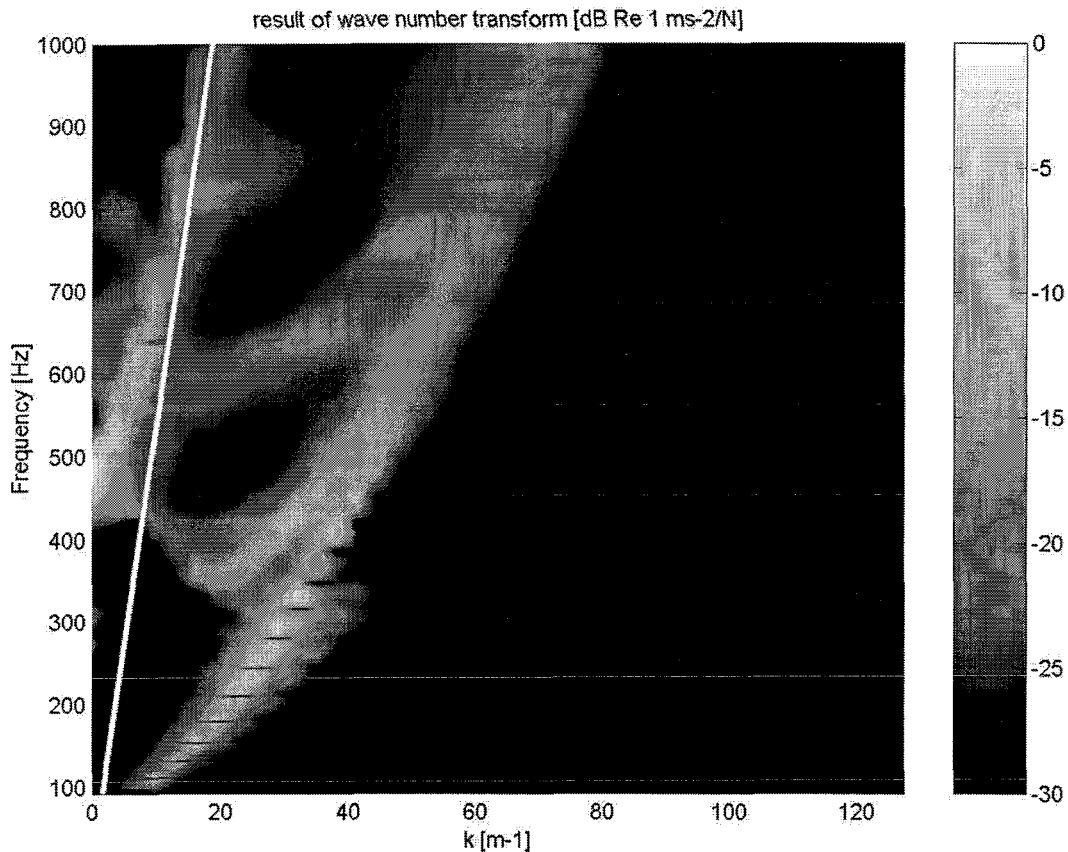
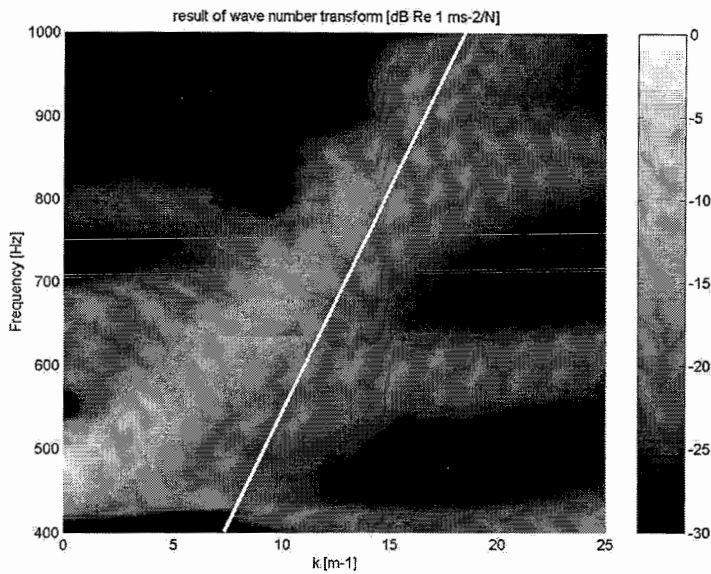

Figure 6.5 Result of the wave number transform for the modified tyre. The thick white line is the dispersion relation of sound waves in air

Figure 6.5 shows the result of the wave-number transform for the modified tyre. The results for the modified tyre are very similar to those obtained for the standard tyre. In figure 6.5 the different cross-sectional modes can also be distinguished. The only difference is that the dispersion curves are moved to slightly lower frequencies.



The only difference is that the dispersion curves are moved to slightly lower frequencies. About 9 %, as the resonance frequency is proportional to  $\sqrt{c/m}$  (see App IV). This can be seen if one compares figure 6.6 with 6.4. The curve of the first cross-sectional mode lies closer to the white line in figure 6.6 than in figure 6.5. However the difference is so small that the influence on the radiated sound is probably negligible. The fact that even a 20% mass increase does

Figure 6.6 Close-up of the first cross-sectional mode from figure 6.5

The fact that even a 20% mass increase does

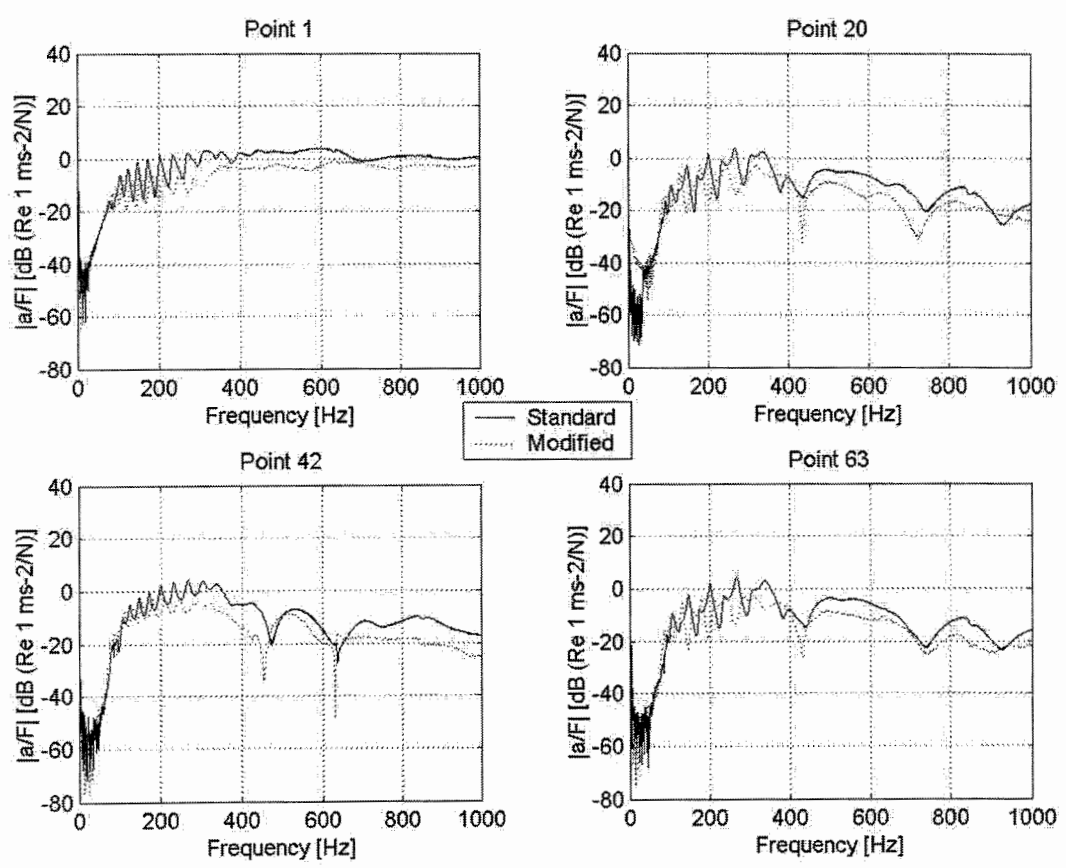

Figure 6.7 Comparison of the acceleration levels in four positions on the standard as well as the modified tyre

not influence the dispersion characteristics of the tyre a lot suggests that it is difficult to influence these properties through extra mass. To see if there is a larger difference between a Vredestein tyre and tyres from another manufacturer, the same experiment was carried out with two Bridgestone tyres of nearly the same size. One normal tyre and one run-flat tyre. The results can be seen in figures 6.8 - 6.10.

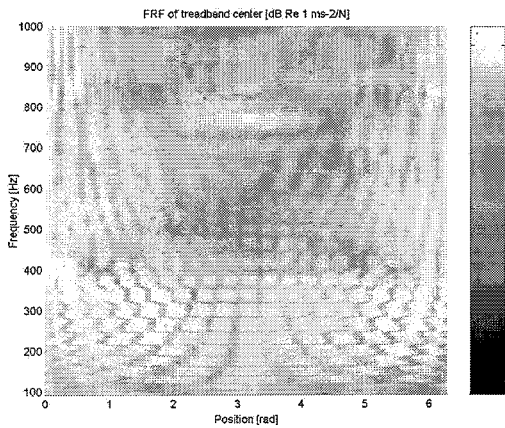

Figure 6.8 a) FRFs of the 80 measurement points of the normal Bridgestone tyre

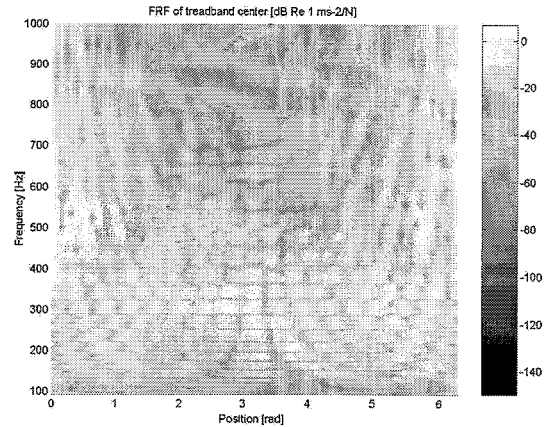

Figure 6.8 b) FRFs of the 80 measurement points of the Bridgestone run-flat tyre

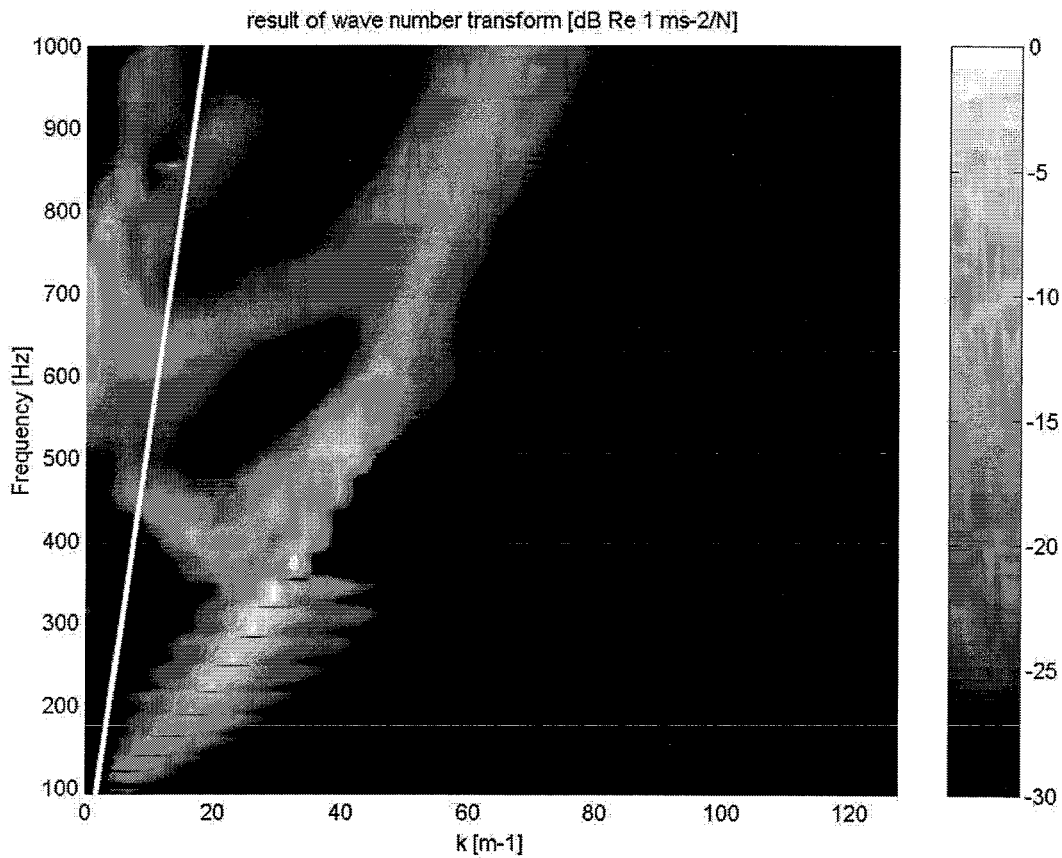

Figure 6.9 Result of the wave number transform for the normal Bridgestone tyre. The thick white line is the dispersion relation of sound waves in air

As can be seen in figure 6.9 the results for the normal Bridgestone tyre are different from the results for the standard Vredestein Ultrac. Especially the first cross-sectional mode ( $m=1$ ) differs a lot from the same mode for the Vredestein tyre. For the Ultrac this mode cuts on at 500 Hz, while for the Bridgestone the first cross-sectional mode starts at about 700 Hz. If one compares the results for the run-flat tyre (fig. 6.10) to

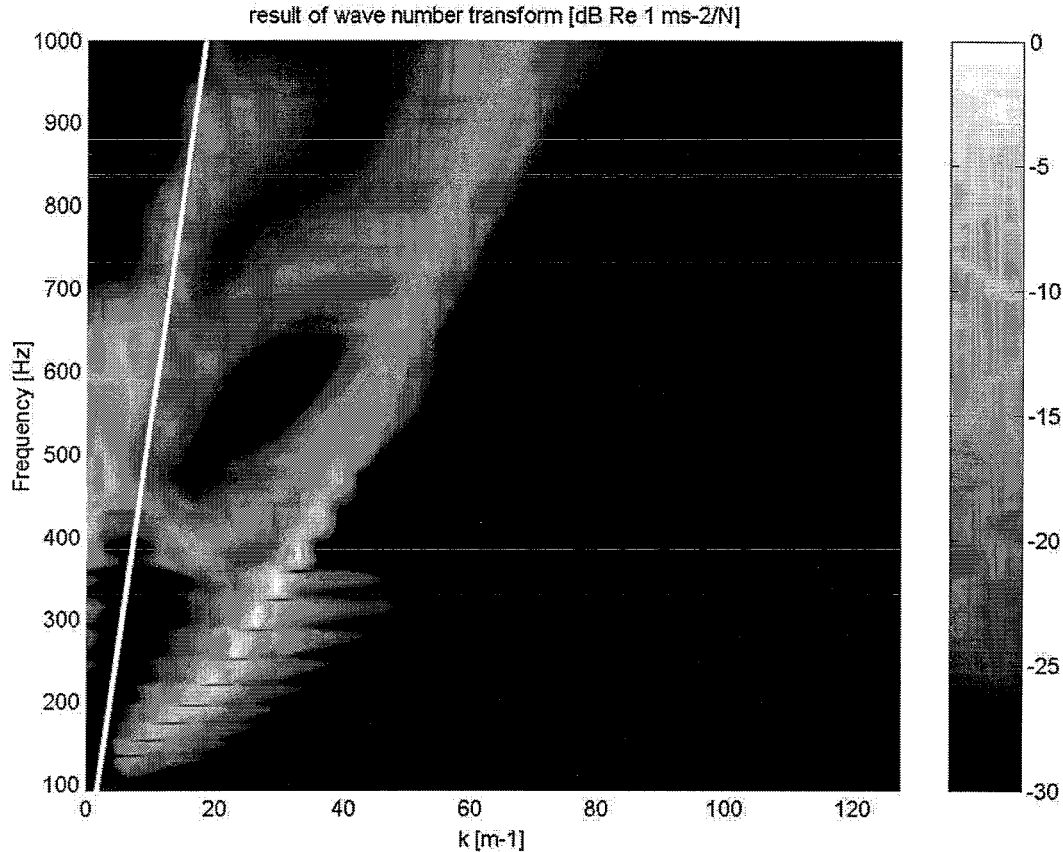

Figure 6.10 Result of the wave number transform for the Bridgestone run-flat tyre. The thick white line is the dispersion relation of sound waves in air

those for the normal tyre, it appears that only the first cross-sectional mode is influenced significantly. The mode is shifted from  $\pm 700$  Hz for the normal tyre to  $\pm 450$  Hz for the run-flat tyre. The main difference between the normal Bridgestone tyre and the other tyres is that the normal Bridgestone is a Y-tyre (maximum speed 300 km/h), while the other tyres are W-tyres (maximum speed 270 km/h). To be able to reach the higher velocity with the same tyre structure it is probably necessary to increase the pre-stress in the nylon overhead to prevent the tyre from expanding too much at high velocities. This may be the reason for the shift of the first cross-sectional mode ( $m=1$ ). The reason that the effect is greater on this mode than on the others is that the first cross-sectional mode is believed to be related to the extensional stiffness of the treadband while the other modes are associated with the membrane and flexural stiffness of the tyre carcass.[Bolton & Kim, 2000] The higher pre-stress in the nylon overhead increases the extensional stiffness but on the other hand offers little resistance to bending. The run flat tyre is a W-tyre and has only one nylon layer instead 2 as the other three tyres have. This, together with the extra mass which is concentrated in the sidewalls, is probably the reason for the big difference concerning the first cross-sectional mode.

### § 6.3 Discussion

The results from the experiments clearly show that even for very different tyre constructions there is still only one mode that is able to radiate sound efficiently: the first cross-sectional mode. It has been shown that this mode can be influenced through tyre construction. It seems that the pre-stress in the nylon overhead has a great influence on the first cross-sectional mode. To verify this, experiments should be done on two identical tyres except for a different pre-stress in the nylon overhead.

The problem with changing the dispersion characteristics for lowering the noise radiation is that the changes that are favourable for changing the position of the first cross-sectional mode (adding mass and lowering stiffness) have negative effects on other properties of the tyre (e.g. rolling resistance, cost, maximum speed). Furthermore simply lowering the stiffness will also increase the vibration levels on the tyre, which may compensate the decrease of radiation efficiency.

The aim of these experiments was to get a better insight into the belt resonances and see if they could be responsible for the wide peak around 1 kHz in the frequency spectra of the tyre/road noise of most tyres. The experiments do not point to one single mode which may be responsible for the peak. On the other hand one cannot conclude that the belt resonances are not the main cause either.

If one looks at the frequency spectra of the tyre/road noise of different tyres (e.g. figure 5.1) one can see that the peak starts at 500-700 Hz - which is also about the cut-on frequency of the first cross-sectional wave - and starts to drop at about 1200 Hz. - from where excitation from the impact mechanisms probably decreases. Furthermore most figures present the noise levels in 1/3-octave bands. This means that even if due to a different velocity or tread pattern another mode is excited, this mode will probably still fall into the same 1/3-octave band (or else the band next to it) and the level of that band will stay the same. Therefore the location of the peak will not change (much). To determine whether or not the belt resonances are responsible for the peak a narrow band spectrum of the tyre/road noise is needed. One can then compare the frequencies at which of the peaks in this spectrum appear to the resonance frequencies of the first cross-sectional mode.

To determine the importance of the first cross-sectional mode in overall tyre/road noise, noise measurements should be carried out with tyres with different dispersion characteristics, but the same tread pattern. For example tyres with different weight and belt stiffness.

## **Chapter 7 Conclusions & recommendations**

### **§ 7.1 Conclusions**

Tyre/road noise generation mechanisms can be divided into two groups:

- Vibrational mechanisms
- Aerodynamical mechanisms

For tyre manufacturers the most important mechanism of the first group is the tread impact mechanism. This mechanism can be influenced by tread pattern design as discussed in chapter 3.

For the second group of mechanisms it is much more difficult to indicate which mechanism is most important. Air pumping as well as the air resonance mechanisms seem to be important. These mechanisms can also be strongly influenced by tread pattern design.

Furthermore there is another group of mechanisms which cannot be regarded as pure generation mechanisms, but they do influence the noise emission in a significant way. An important mechanism from this group that can be influenced through tyre design is belt resonance.

This last mechanism is investigated further by experiment because this mechanism is thought to be the cause of the peak in the frequency spectra at 1 kHz. Experiments show that for all tyres there is probably only one cross-sectional mode which is able to radiate sound efficiently. The mode can be influenced through tyre construction, although the influence of extra mass seems to be rather small. The large difference between the normal Bridgestone tyre and the other tyres is believed to be caused by the pre-stress in the nylon overhead of this tyre. This increases the extensional stiffness of the tread, which influences the first cross-sectional mode significantly. This will have to be confirmed through experiments though. At this point it is not possible to tell whether or not the belt resonances are responsible for the above-mentioned peak and further experiments are needed.

### **§ 7.2 Recommendations**

- The overall A-weighted sound pressure level which is measured at this moment at pass-by measurements gives no information on the origin of the generated sound. With some equations from chapter 2 it is possible to determine which mechanism may be responsible for a certain sound, but to do that one has to know the frequency at which the sound occurs. Therefore it has to be possible to perform a narrow band analysis of the measured tyre/road noise.
- To determine the effect of the different dispersion characteristics as measured in chapter 6 on the overall noise level, sound measurements (narrow band, see §6.3) should be carried out. In this experiment tyres with the same tread pattern, but different structure (and therefore different dispersion characteristics) should be used.
- To check whether the nylon overhead is the cause of the shift of the first cross-sectional mode, a Ultrac with a different pre-stress in the nylon overhead should be made. The dispersion characteristics of this tyre should be compared to the characteristics for the standard Ultrac.

## References

- Andersson, P.; (2003)**, *Personal communication by e-mail with Mr Andersson at Chalmers University of Technology, Department of Applied Acoustics, Goteborg, Sweden*
- Anderson, P.; Larsson, K.; (2003)** *Validation of a high frequency tyre model based on the elastic field equations*, Proc. Of the Tenth international congress on sound and vibration, Stockholm, Sweden, July 7-10 2003
- Böhm, F.; (1966)**, *Mechanik des Gürtelreifens*, Ing.-Arch, 35 82
- Bolton, J.S.; Kim, Y.J.; (2000)** *Wave number domain representation of tire vibration*, Proc of internoise 2000, 27-30 August, Nice, France
- Bolton, J.S.; Yum, K.; Kim, Y.J.; (2002)** *Sound radiation from point excited tyres*, presentation at the Ray W. Herrick Laboratories, School of Mechanical Engineering Purdue University, September 19, 2002
- Bschorr, O.; (1985)** *Reduction of tire noise* Proc. Of Inter-noise 85 Munich, Germany, pp 271-274
- De Roo, F.; Gerretsen, E.; (2000)** *TRIAS – Tyre road interaction acoustic simulation model*, Proceedings of Internoise 2000 27-30 August, Nice, France
- De Roo, F.; Gerretsen, E.; Mulder, E.H.; (2001)** *Predictive performance of the tyre-road noise model TRIAS*, Proceedings of Internoise 2001 27-30 August, The Hague, Netherlands
- De Roo, F.; Gerretsen, E.; Hoffmans, W.G.J.; Doelman, N.J.; (1999)** *Dutch tyre-road noise emission model – Adjustments and validation*, Proc. Of Internoise 1999 Fort Lauderdale, USA, 6-8 September 1999
- Ejsmont, J.A.; Sandberg, U.; Taryma, S.; (1984)** *Influence of tread pattern on tire/road noise* SAE Paper No. 841238, SAE Technical paper series, Society of Automotive Engineers, Warrendale, PA. USA
- Ejsmont, J.A.; (2000)** *Tire/road noise simulation for optimization of the tread pattern* Proc of internoise 2000, Nice, France
- Gagen, M. J.; (1999)**, *Novel acoustic sources from squeezed cavities in car tires*, Journal of the acoustic Society of America 106 (2),794-801
- Graf, R.A.G.; Kuo, C.Y.; Dowling, A.P.; Graham, W.R.; (2002)**, *On the horn effect of a tyre/road interface, part I: experiment and computation*, Journal of Sound and Vibration 256 (3) ,417-431
- Haverkamp, M.; (1999)** *Untersuchung der hohlraumresonanz im reifen durch analyse der energieübertragung*, VDI Berichte Nr. 1494, 1999, p 107-116, Verein Deutscher Ingenieure, VDI-Gesellschaft, Düsseldorf, Germany
- Hayden, R.E.; (1971)** *Roadside noise from the interaction of a rolling tyre with the road surface*, Proc. Of the Purdue Noise Control conference, Purdue University, Indiana, USA
- Heckl, M.; (1986)**, *Tyre noise generation*, Wear, 113, 157-170
- Iwao, Keijiro; Yamazaki, Ichiro; (1996)** *A study on the mechanism of tyre/road noise*”. JSAE Review 17 (1996) 139-144 Society of Automotive Engineers of Japan.
- Kim, Y-J; Bolton, J.S.; (2001)**, *Modeling tire treadband vibration*, Proceedings of Internoise 2001 27-30 August, The Hague, Netherlands
- Kim, Y-J; Bolton, J.S.; (2003)**, *Effects of rotation on the dynamics of a circular cylindrical shell with application to tire vibration*, Journal of Sound and Vibration, article in press at time of writing

- Kropp, W.; Larsson, K.; Barrelet, S.; (1998)** *The influence of belt and treadband stiffness on the tyre noise generation mechanisms*, Proc. Of the International Congress on Acoustics (ICA) 1998, Seattle, WA, USA.
- Larsson, K.; Kropp, W.; (2002)**, *A high frequency three-dimensional tyre model based on two coupled elastic layers*, Journal of Sound and Vibration 253(4) 889-908
- Matsuoka, H.; Okuma, M.; (2002)** *A new experimental modal parameter estimation method for cylindrical structures by standing wave decomposition and application to tire modelling*, Proc. Of ISMA 2002 Katholieke Universiteit Leuven, Belgium, September 16-18 2002
- Muthukrishnan, M.; (1990)** *Effects of material properties on tire noise* SAE Technical paper series no. 900762, Society of Automotive Engineers, Warrendale, PA., USA
- Pietrzyk, A.; (2001)** *Prediction of the dynamic response of a tire*, Proc. of Internoise 2001, The Hague, The Netherlands, August 27-30
- Saemann, E-U.; Schmidt, H.; (2002)** *Schallmessungen bei der entwicklung von reifen mit geringen vorbeifahrtpegel* Zeitschrift für Lärmbekämpfung, 49 (2002), No. 2, March 2002
- Sandberg, U; (2001)** *Tyre/road noise – myths and realities*, Proc. of Internoise 2001, The Hague, The Netherlands, August 27-30
- Sandberg, U; (2003)** *The multi-coincidence peak around 1000 Hz in tyre/road noise spectra*, Proc. Of Euronoise 2003, Naples, Italy
- Sandberg, U.; Ejsmont, J.A.; (2002)**, *Tyre/road noise reference book*, Informex, SE-59040 Kisa, Sweden (www.informex.info)
- Soedel, W; (1975)**, *On the dynamic response of rolling tires according to thin shell approximations*, Journal of Sound and Vibration 41(2) 233-246
- Wullens, F.; Kropp, W.; (2001)** *Influence of the local stiffness of the rubber layer of the tyre on the generation of tyre/road noise* Proc. Of ICA 2001, Rome Italy
- Wullens, F.; Kropp, W.; (2003)**, *A three-dimensional rolling contact model for the description of the tyre/road interaction*, Proceedings of the Tenth International Congress on Sound and Vibration 7-10 July 2003, Stockholm, Sweden
- Yamauchi, H.; Akiyoshi, Y.; (2002)** *Theoretical analysis of tire acoustic cavity noise and proposal of improvement technique* JSAE Review 23 (2002) 89-94 Society of Automotive Engineers of Japan



### Appendix I

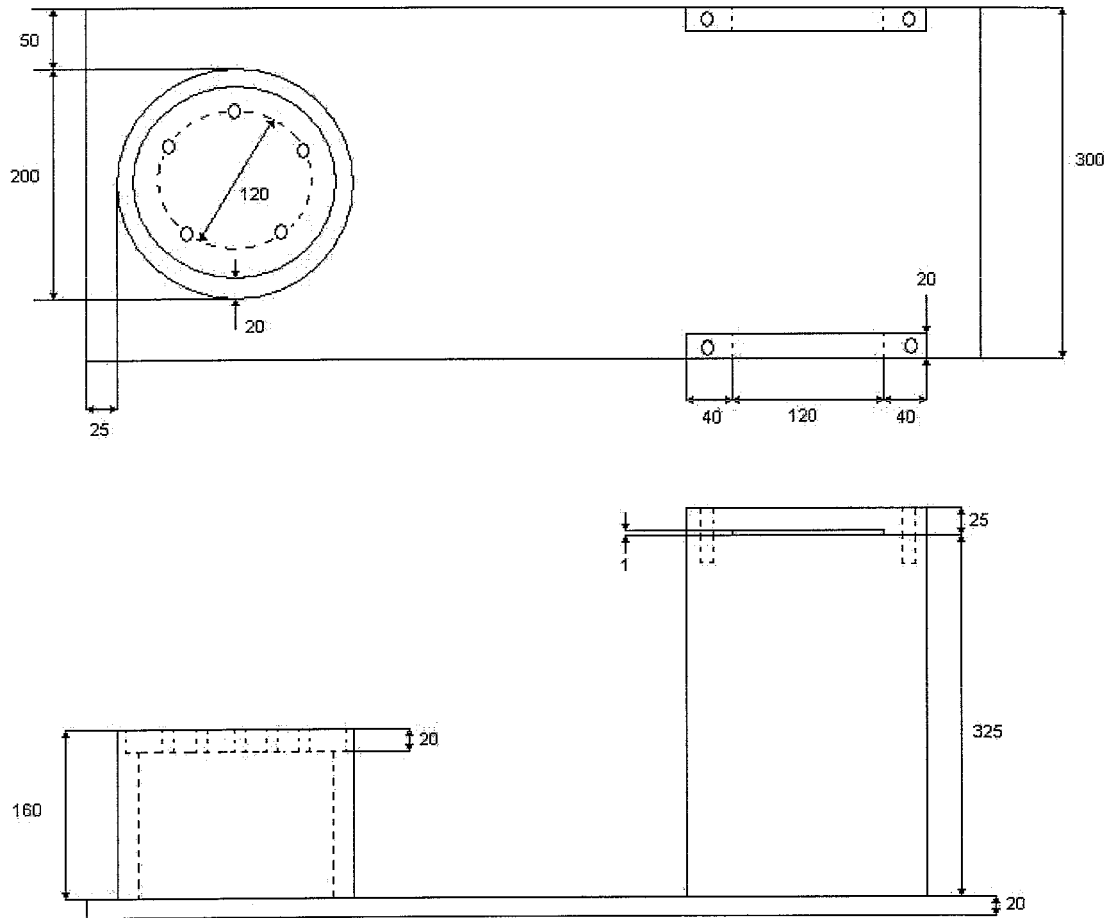

*Figure I.1 Drawing of the construction*

## Appendix II

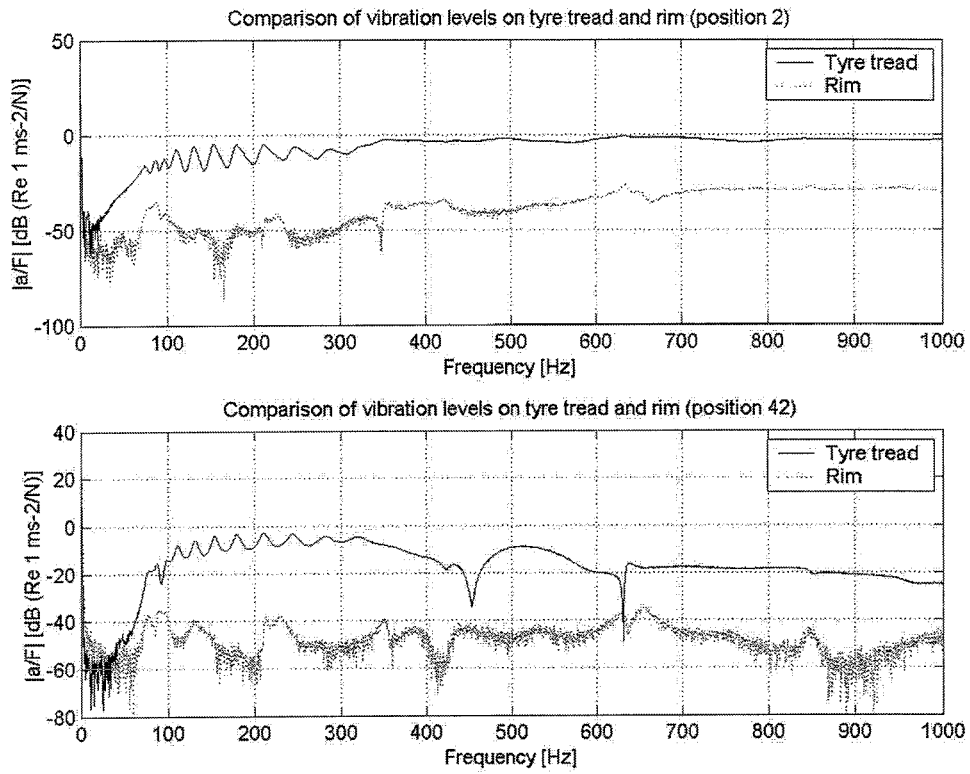

Figure II.1 Comparison of acceleration levels on the tyre tread and on the rim. Position 2 is near the excitation point and point 42 is halfway around the tyre.

## Appendix III

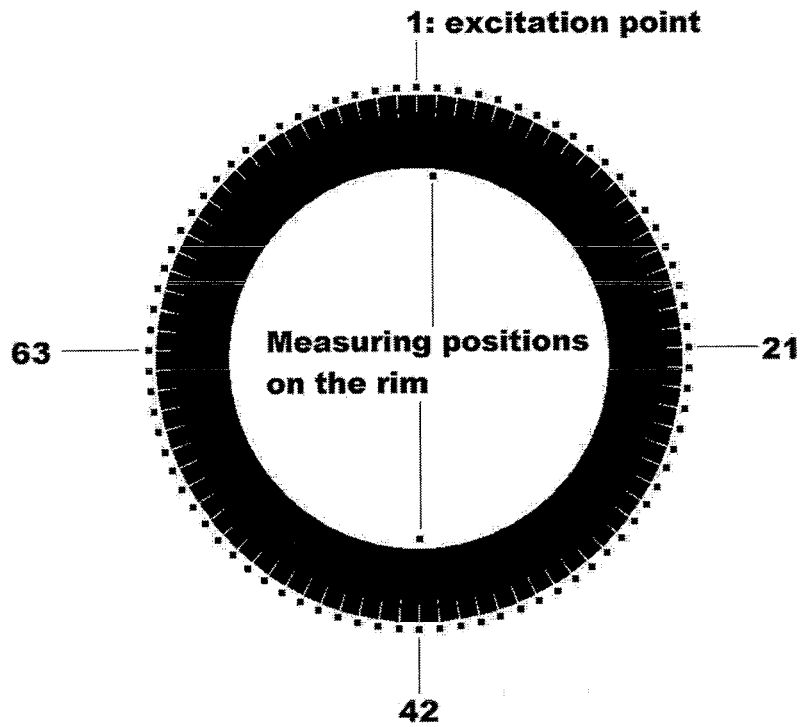

Figure III.1 Sketch of the measurement positions

### Appendix IV

The theoretical relation between frequency, stiffness and mass:

$$f \text{ is proportional to } \sqrt{c/m} .$$

So for the standard tyre:

$$f_1 \approx \sqrt{c_1/m_1}$$

and the modified tyre, where the stiffness is assumed to be equal to the stiffness of the standard tyre.

$$f_2 \approx \sqrt{c_1/m_2}$$

This means:

$$\frac{f_1}{f_2} = \sqrt{\frac{m_2}{m_1}} = \sqrt{1.2} = 1.095$$

So a difference of about 9 – 10 % between the resonance frequencies.

This seems to correspond rather well with the results from figure 6.3 and 6.5. In figures IV.1 and IV.2 the ratio between the frequencies of the cross-sectional mode with m=3 is shown.

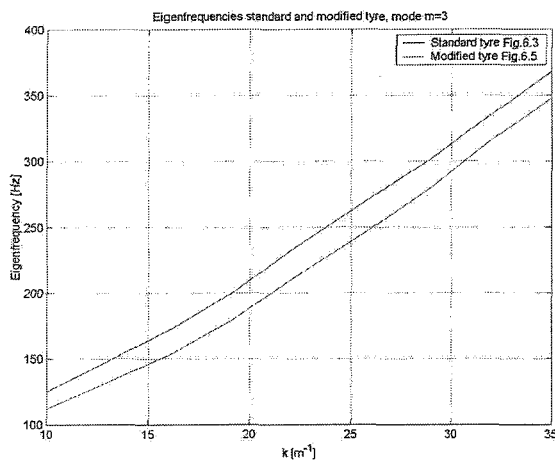

Figure IV.1 Cross-sectional mode with m=3 for the modified and standard tyre

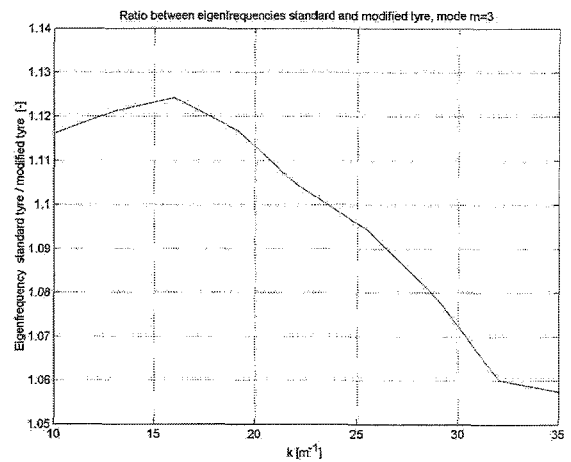

Figure IV.2 Ratio between the cross-sectional mode with m=3 for the modified and standard tyre