

## Occupant simulation as an aspect of flight safety research

***Citation for published version (APA):***

Nieboer, J. J., Wismans, J. S. H. M., & Verschut, R. (1992). Occupant simulation as an aspect of flight safety research. In *Aircraft accidents : trends in aerospace medical investigation techniques : papers presented at the Aerospace Medical Panel symposium held in Cesme, Turkey, 27 April - 1 May 1992* (pp. 14.1-14.9). (AGARD conference proceedings; Vol. 532). AGARD.

***Document status and date:***

Published: 01/01/1992

***Document Version:***

Publisher's PDF, also known as Version of Record (includes final page, issue and volume numbers)

***Please check the document version of this publication:***

- A submitted manuscript is the version of the article upon submission and before peer-review. There can be important differences between the submitted version and the official published version of record. People interested in the research are advised to contact the author for the final version of the publication, or visit the DOI to the publisher's website.
- The final author version and the galley proof are versions of the publication after peer review.
- The final published version features the final layout of the paper including the volume, issue and page numbers.

[Link to publication](#)

***General rights***

Copyright and moral rights for the publications made accessible in the public portal are retained by the authors and/or other copyright owners and it is a condition of accessing publications that users recognise and abide by the legal requirements associated with these rights.

- Users may download and print one copy of any publication from the public portal for the purpose of private study or research.
- You may not further distribute the material or use it for any profit-making activity or commercial gain
- You may freely distribute the URL identifying the publication in the public portal.

If the publication is distributed under the terms of Article 25fa of the Dutch Copyright Act, indicated by the "Taverne" license above, please follow below link for the End User Agreement:

[www.tue.nl/taverne](http://www.tue.nl/taverne)

***Take down policy***

If you believe that this document breaches copyright please contact us at:

[openaccess@tue.nl](mailto:openaccess@tue.nl)

providing details and we will investigate your claim.

# Occupant Simulation as an Aspect of Flight Safety Research

J.J. Nieboer, J. Wismans and R. Verschut

TNO Crash-Safety Research Centre

P.O. Box 6033

2600 JA Delft, The Netherlands

## ABSTRACT

In the field of flight safety research there is a growing interest for mathematical simulation of human response and injuries associated with survivable aircraft accidents. A mathematical tool can be very helpful to evaluate and improve on-board restraint systems or to assess the effectiveness of different seat designs. The passenger brace position, being a human factor, can be evaluated efficiently as well.

MADYMO is a well accepted integrated multibody/finite element program for Crash Victim Simulation. Recently the two-dimensional version of MADYMO was successfully applied for reconstruction of seat and passenger behaviour during the M1 Kegworth air accident. In this paper a brief description of MADYMO as well as three flight safety applications are presented. Special attention is given to the application concerning a dynamic seat test involving a 50<sup>th</sup> percentile Hybrid II dummy and a P3/4 dummy, representing a nine-month-old child, seated in a child seat. The MADYMO model used for this application was validated on the basis of sled test results. It can be learned that MADYMO is capable of predicting passenger and seat response in an aircraft crash environment. A discussion on future developments in this field concludes this paper.

## INTRODUCTION

In safety research the simulation of crashes is of vital importance in order to evaluate and improve safety devices and human body surroundings. Most of this work is done experimentally with instrumented dummies or human cadavers. Occasionally animals or human volunteers are used. During the past years a strong increase could be observed in the use of computer simulations due to both the fast developments in computer hardware and simulation software. Simulation programs can contribute significantly to the insight into impact behaviour of complex dynamical systems, particularly if models are used to complement experimental work.

Examples of computer simulation programs for aircraft crash safety analyses are KRASH, SOMLA/SOMTA (Seat Occupant Model-Light Aircraft/Seat Occupant Model-Transport Aircraft) and ATB (Articulated Total Body). The program KRASH uses masses interconnected by massless beams and springs to model the crash behaviour of aircraft structures, while seats and passengers can be represented by mass-spring systems in order to obtain a rough indication on

the injuries sustained [9,13]\*. Figure 1 shows a KRASH model of a helicopter. The programs SOMLA and SOMTA combine a three-dimensional multibody model of aircraft occupants with a finite element model of the seat structure [3,14]. SOMLA models a single occupant, whereas SOMTA has the capability to model up to three passengers. Only a fixed number of segments can be specified for representation of the occupant in SOMLA/SOMTA. The ATB program is based on the CAL 3D multibody model for crash victim simulation in the automotive field [1]. Several modifications were introduced, e.g. the capability to apply aerodynamic forces to the human body.

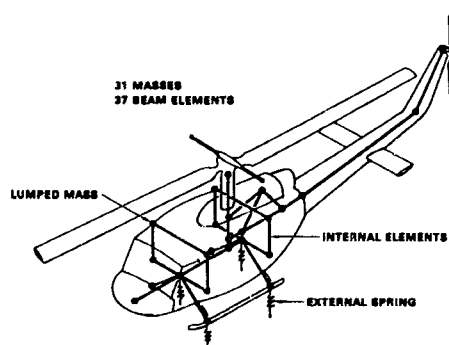

Fig. 1 KRASH model of a helicopter [13].

Due to modification of the Federal Aviation Regulations (FARs) in view of an increased on-board passive safety level and the growing awareness that a notable high percentage of aircraft crashes are survivable nowadays, the aeronautics industry starts to use advanced simulation tools which are customary in the automotive industry. Among these tools are several explicit finite element codes, especially useful to determine the crash behaviour of aircraft structures, and the integrated multibody/finite element program for crash analyses MADYMO. The main emphasis of this program is the prediction of the kinematics and dynamic behaviour of crash victims. Recently the two-dimensional version of this program was successfully applied for reconstruction of seat and passenger behaviour during the M1 Kegworth air accident [10,11].

\* Numbers in parentheses designate references at the end of paper.

In this paper first a brief description of MADYMO is given as well as an overview of available crash dummy databases. Then some earlier MADYMO flight safety applications will be discussed, namely the in-flight escape of a crew member from the Space Shuttle and a three-dimensional simulation of seat and passenger behaviour during the M1 Kegworth air accident. A third more recent example to be presented concerns the simulation of a dynamic seat test involving a 50<sup>th</sup> percentile Hybrid II dummy and a P3/4 dummy, representing a nine-month-old child, seated in a child restraint system. Simulation results obtained from this example will be compared with the actual sled test results. Different concepts for modelling the seat structure will be addressed. A discussion on the possible contribution of computer simulations to the overall flight safety problem and future MADYMO developments concludes this paper.

**MADYMO**

MADYMO is a world-wide accepted engineering analysis program, developed by the TNO Crash-Safety Research Centre, for the simulation of systems undergoing large displacements. The program has been designed especially for the study of the complex dynamical response of the human body and its environment under extreme loading conditions like they occur in crash situations. But also for other dynamic events, like the simulation of vehicle riding and handling the program has been applied successfully. MADYMO combines in one simulation program, in an optimal way, the capabilities offered by the multibody approach (for the simulation of the gross motion of systems of bodies connected by complicated kinematical joints) and the finite element method (for the simulation of structural behaviour).

The multibody part of the program uses a relative description for the kinematics of systems of bodies. The generation of the equations of motion is based on the principle of virtual work in combination with a recursive algorithm for the motion of the bodies. This formulation offers a very versatile and economical way for the description of the motions in arbitrary kinematical joints. Figure 2 illustrates a number of standard joints available in MADYMO (version 5.0). In addition to these joints a user can define new joint types by means of user defined routines.

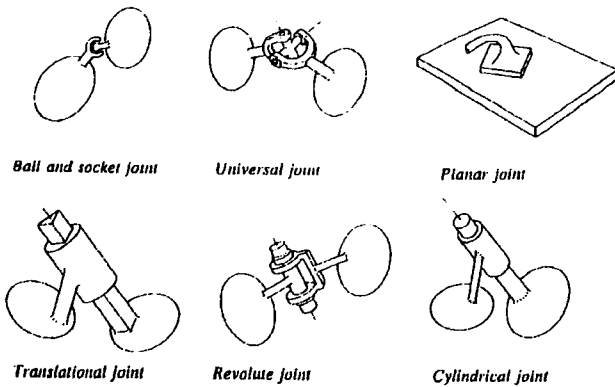

**Fig. 2** Standard 3D kinematic joints in MADYMO.

To the bodies ellipsoids or planes can be connected for contact interaction with other bodies and the environment. Moreover a library of force models is available including, for instance, belt models, airbags and several types of spring and damper elements [4].

For the simulation of structural deformations the multibody elements can interact with structures modelled with finite elements. Triangular membrane elements of constant thickness with special material models for fabrics have been implemented for the simulation of airbag dynamics (see Figure 3) [8,15,16,18]. In addition interfaces are available between MADYMO and the explicit FEM codes PAM-CRASH, LS-DYNA3D and DYTRAN for integrated human body-vehicle structural crash analysis [7].

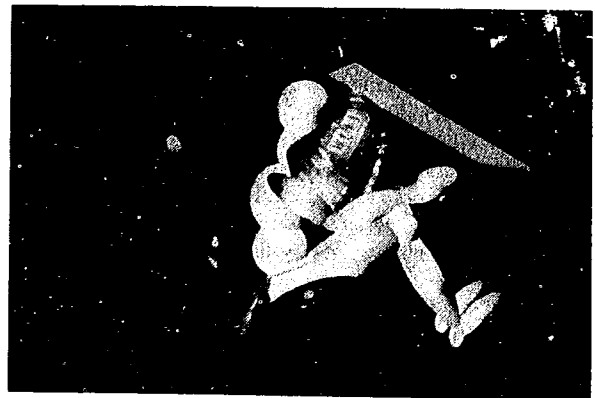

**Fig. 3** Example of coupled MADYMO multibody/FEM simulation.

MADYMO as an injury biomechanics program offers, in addition to standard output quantities like displacements and accelerations, which can be visualized through advanced animation and time-history programs, the possibility to calculate injury criteria like femur and tibia loads, internal joint loads, HIC, SI, TTI, and V\*C.

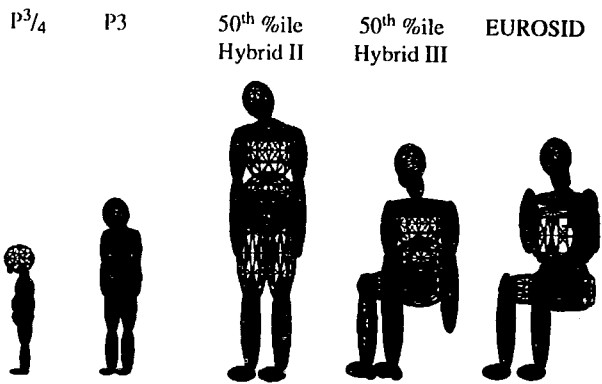

**Fig. 4** Some of the standard crash dummy databases available in MADYMO.

An important requirement for an effective use of computer models in the field of crash simulations is that reliable well validated descriptions for the human body are available. MADYMO offers a number of standard databases for crash dummies [5]. Some of them are illustrated in Figure 4, i.e.

models for the nine-month (P3/4) and three-year-old (P3) TNO child dummies, the 50<sup>th</sup> percentile adult frontal impact dummies Hybrid II and Hybrid III and the European side impact dummy EUROSID. Databases for the USA side impact dummy SID, and the 5<sup>th</sup>- and 95<sup>th</sup> percentile Hybrid III dummies are available as well. In addition to crash dummy databases also capabilities are offered in MADYMO to generate real human body anthropometry and mass distribution data.

### EARLIER MADYMO FLIGHT SAFETY APPLICATIONS

Among the MADYMO applications and validation studies published in the past [12] are simulations of occupants in frontal and side impacts, pedestrians and cyclists hit by a passenger car front, wheelchair occupants during transport, a child in a child restraint system, simulation of human body segments in a crash environment and evaluation of sports protection devices. In addition, several studies were carried out on truck driver safety, pedestrians and cyclists contacting a truck front or various side structures of the trailer and motorcycle simulations.

In this paper first two earlier flight safety applications will be briefly discussed; an in-flight escape of a crew member from the Space Shuttle and the three-dimensional seat and passenger behaviour during the M1 Kegworth air accident.

#### Space Shuttle escape

The simulation concerns the in-flight escape of a Space Shuttle crew member [2]. One of the potential methods evaluated by NASA to obtain a safe escape from the Space Shuttle made use of a tractor rocket escape system. The astronaut is laying backwards on a horizontal ramp with his feet placed on a vertical foot plate. A small hatch at the side of the Space Shuttle is available for the escape. The crew member harness system is connected to the tractor rocket by means of an elastic rope, further referred to as pendant line. After ejection of the tractor rocket the pendant line will become stretched and the astronaut is pulled through the hatch opening.

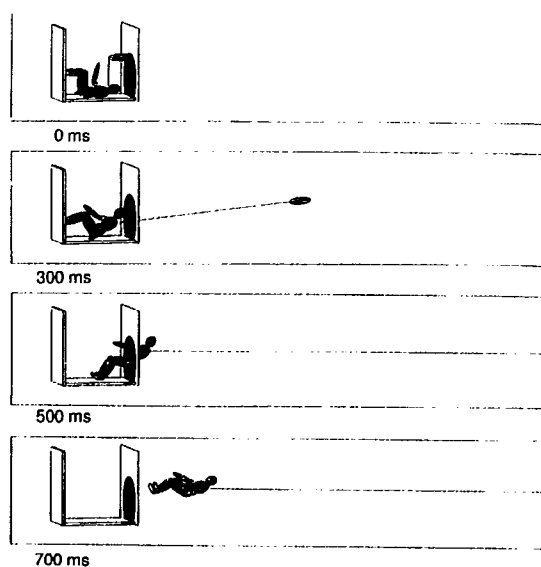

Fig. 5 Space Shuttle escape simulation.

Anthropometry, mass distribution and joint properties of the astronaut model are based on a 50<sup>th</sup> percentile Hybrid II dummy. Aerodynamical forces on the astronaut are described as an acceleration field. The propulsion force on the rocket is estimated. The pendant line is simulated by a spring-damper element, both elastic and damping properties are estimated as well. The Space Shuttle itself is represented by a number of contact planes to study the interaction with the astronaut. Figure 5 presents the simulated astronaut and rocket locations during the first 700 ms. By means of the developed model, the influence of different parameters like body size, initial position, pendant line stiffness and pull angle on the astronaut response can be investigated.

#### Aircraft seat and passenger behaviour during a crash

On the night of Sunday the 8<sup>th</sup> of January 1989 a Boeing 737-400 crashed on the M1 motorway near Kegworth in England. Of the 126 passengers on board 79 survived the accident. A comprehensive investigation into the cause and effects of this accident was carried out by a study group of representatives of various organisations. Besides structural, medical and survival aspects attention was paid to the reconstruction of the accident by means of computer simulations. The aircraft overall behaviour during the crash was simulated by Cranfield Impact Centre Ltd. with the program KRASH. From this simulation movements in time and deceleration pulses of different aircraft sections were obtained [9]. The movement and deceleration of the mid section were used as input for MADYMO 2D, allowing an analysis of seat and passenger behaviour during the crash. As a result of this analysis, which was performed by HW Structures Ltd., possible injury mechanisms could be identified [10,11]. The influence of different passenger brace positions on the injuries sustained was studied as well.

The three-dimensional simulation presented here is based on the MADYMO 2D simulations; in fact all input data originate from a Civil Aviation Authority report prepared by HW Structures Ltd. [6]. Figure 6 illustrates the simulated passenger kinematics. Two aircraft seats behind each other are occupied by 50<sup>th</sup> percentile Hybrid III dummies, both dummies are restrained by a regular lap belt. Floor and bulkhead rotation is prescribed in the MADYMO input dataset. A seat is defined as a separate system composed of two elements, for representation of seat cushion and seat back respectively. Both seats are attached to the floor by means of point-restraints, four point-restraints are used for each seat. This model set-up allows for attachment deformation to be taken into account, moreover the seats can easily be moved in the model. Gravity combined with longitudinal, vertical and lateral crash pulse components are applied. As can be learned from Figure 6, quite severe head impact occurs for both passengers when seated in an upright position initially.

#### DYNAMIC AIRCRAFT SEAT TEST

A dynamic aircraft seat test was performed by TNO. This test was carried out in accordance with FAR regulations (Part 25). To account for the effects of floor deformation that may occur during an accident, this regulation prescribes the track on one side of the seat to be rotated 10° about the lateral (pitch) axis and the other track to be rotated 10° about the longitudinal (roll) axis, as illustrated in Figure 7. For the test the seat legs were fixed to a flat steel plate (via the original floor tracks) instead. Figure 8 shows the initial test set-up. The double-seat is occupied by a 50<sup>th</sup> percentile Hybrid II dummy and a P3/4

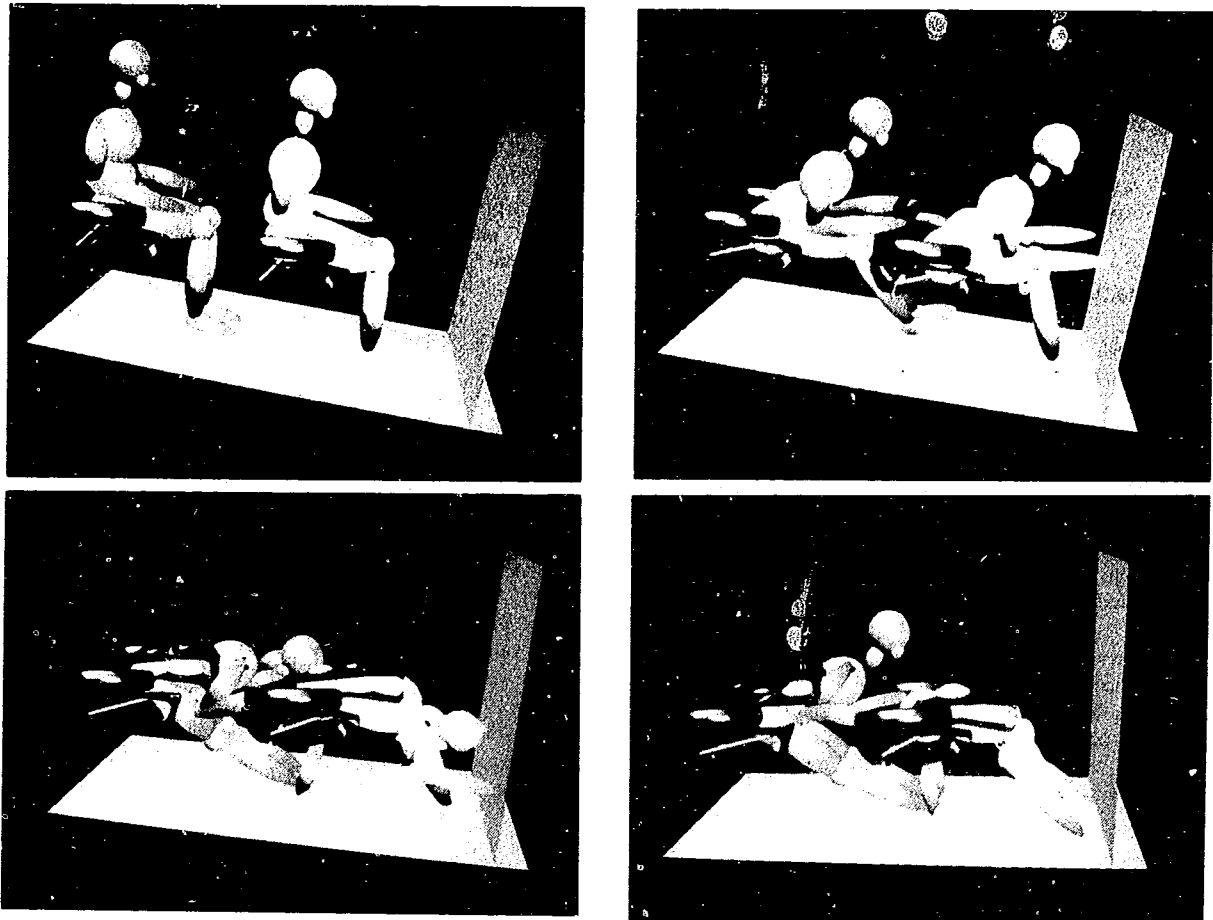

Fig. 6 Simulated seat and passenger behaviour during an aircraft crash.

child dummy in a child seat. Both 50<sup>th</sup> percentile Hybrid II dummy and child seat are restrained by the standard lap belts during the test. The 50<sup>th</sup> percentile Hybrid II dummy was not equipped with a lumbar spine load cell as prescribed in the regulations, since no potential for spinal injuries was anticipated. The double-seat was rotated 10° relative to the acceleration direction of the HYGE sled. Figure 9 shows the acceleration pulse of the sled. As can be seen in this figure the acceleration pulse applied differs only slightly from the ideal triangular pulse as included in the FAR dynamic test requirement. No seat structural deformations of importance could be identified after the test (see Figure 10). Note that the cover of the right armrest has been removed in this figure. The sled test, as described above, was simulated utilizing the MADYMO 3D program.

#### Model set-up

The MADYMO 3D model set-up is given in Figure 11. The double-seat is represented by a system composed of three elements, for modelling seat cushion and both seat backs respectively. Since a similar seat design was tested as the seats on-board of the Boeing 737-400 crashed near Kegworth, most input data was derived from the Civil Aviation Authority report prepared by HW Structures Ltd. [6]. Only a few additional measurements were carried out in order to obtain missing information.

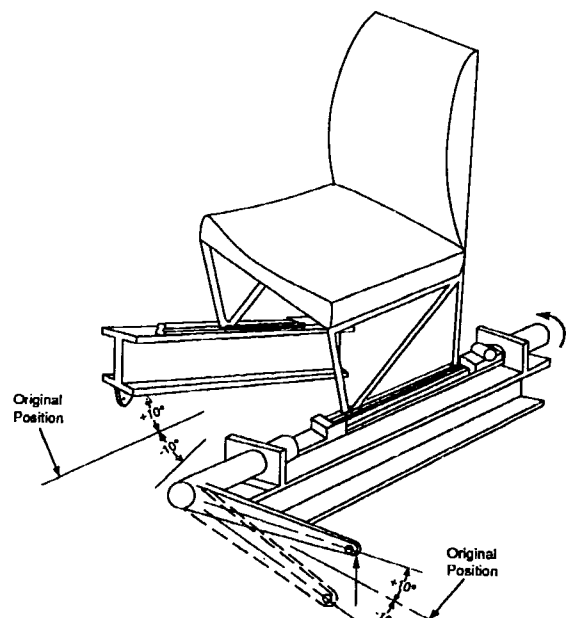

Fig. 7 Floor wrapping conditions according to FAR (Part 25, test 2) [14].



Fig. 8 Dynamic seat test set-up.

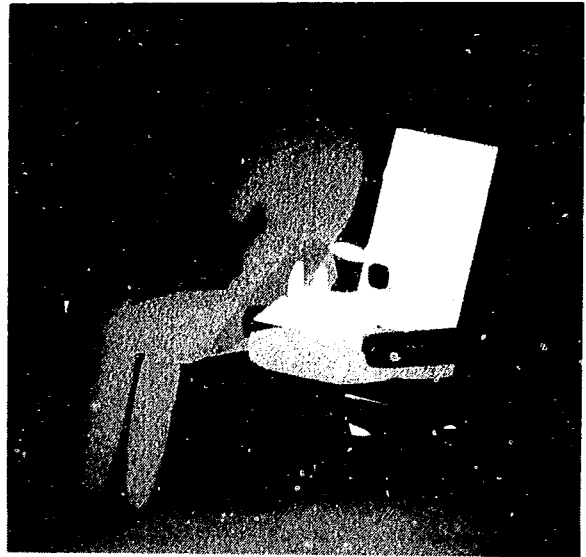

Fig. 11 MADYMO model set-up for dynamic seat test simulation.

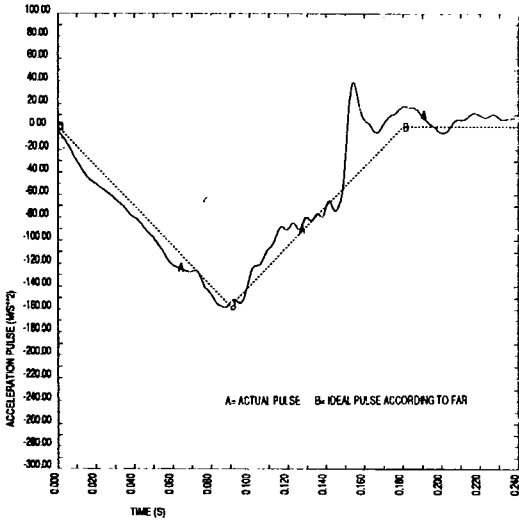

Fig. 9 HYGES sled acceleration pulse.

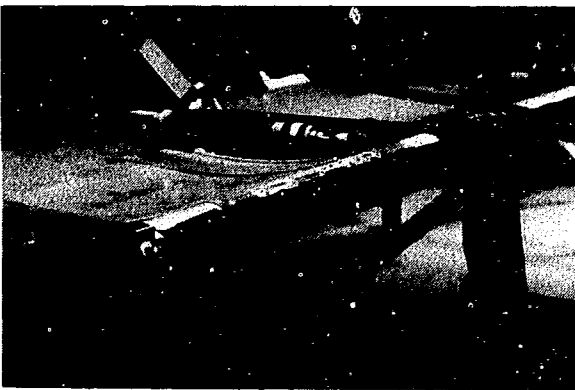

Fig. 10 Seat structure after the test.

**Validation study**

Figure 12 shows the simulated kinematics of both dummies and the child seat (note that higher order ellipsoids are visualized as 2<sup>nd</sup> order ellipsoids in this figure). The validation study presented here will focus on the behaviour of the 50<sup>th</sup> percentile Hybrid II dummy. When comparing the simulated kinematics of this dummy with the kinematics observed during the sled test, it can be learned that the computer model predicts a slightly too fast forward motion of the upper part of the body. In the simulation the Hybrid II dummy does not touch the seat front tube, which could explain why no deformations of the front tube could be identified after the actual test.

The simulated acceleration components of the Hybrid II lower torso and head are compared with the accelerations measured during the experiment in Figure 13, whereas Figure 14 compares the simulated and experimental lap belt forces. These lap belt forces were recorded at the left and right side of the dummy pelvis. In general a fairly good correlation can be observed between simulated and experimental signals. The peak at 140 ms in the lateral and vertical component of the lower torso acceleration signal is probably due to contact with the armrest when the dummy rebounds from the seat. The magnitude of the belt forces is correct, however, the curve shapes could be improved further by taking into account the deformation and rotation of the belt anchor points.

**GENERAL DISCUSSION**

Since its appearance on the market the MADYMO program has been continuously modified and improved. In its present form the program appears to be a very useful tool to users all over the world for simulation and analysis of human body behaviour during a crash or impact. Although primarily used for automotive safety applications, the aeronautics industry shows an increasing interest as well. A lot can be learned from knowledge and techniques which are common use in the automotive industry, such as energy absorbing interior paddings, seat belts, child restraint systems or airbags. Weight,

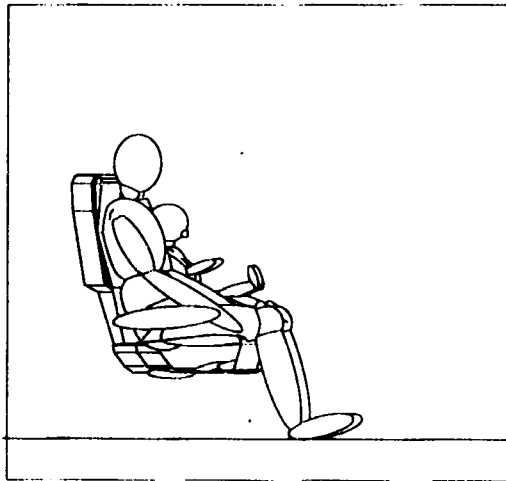

Time: 0. ms

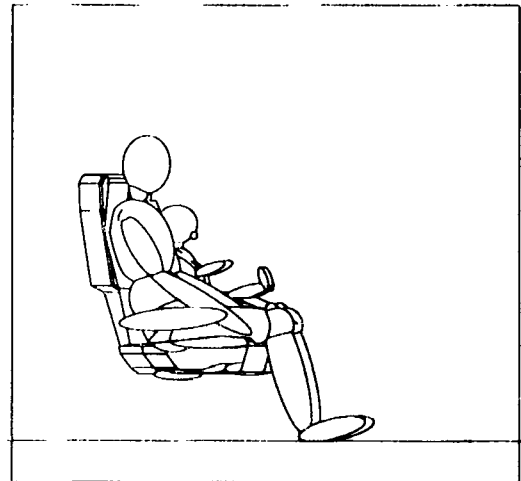

Time: 30. ms

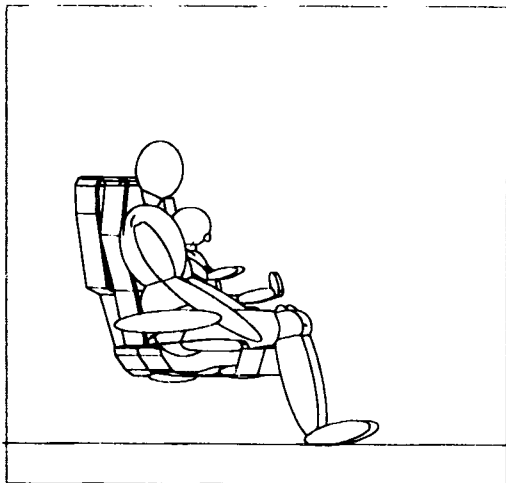

Time: 60. ms

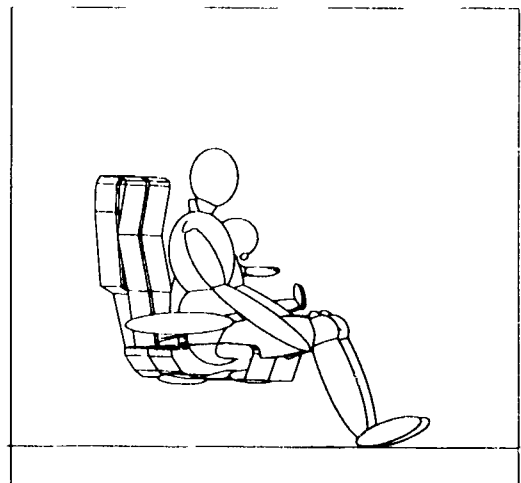

Time: 90. ms

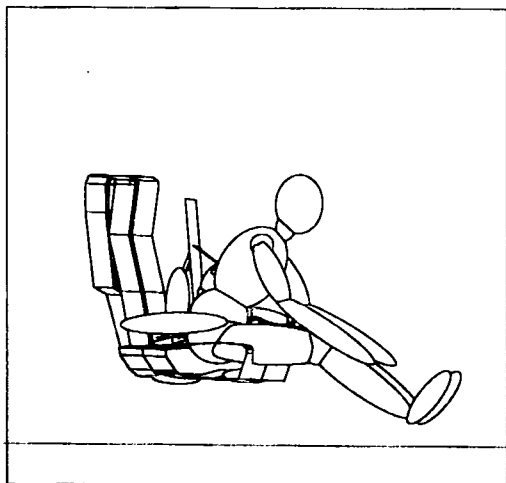

Time: 120. ms

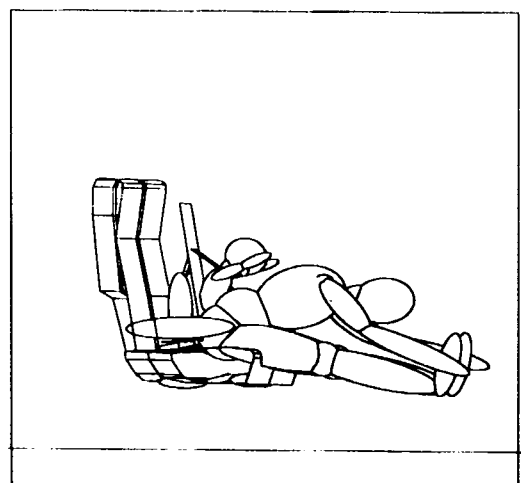

Time: 150. ms

Fig. 12 Simulated kinematics.

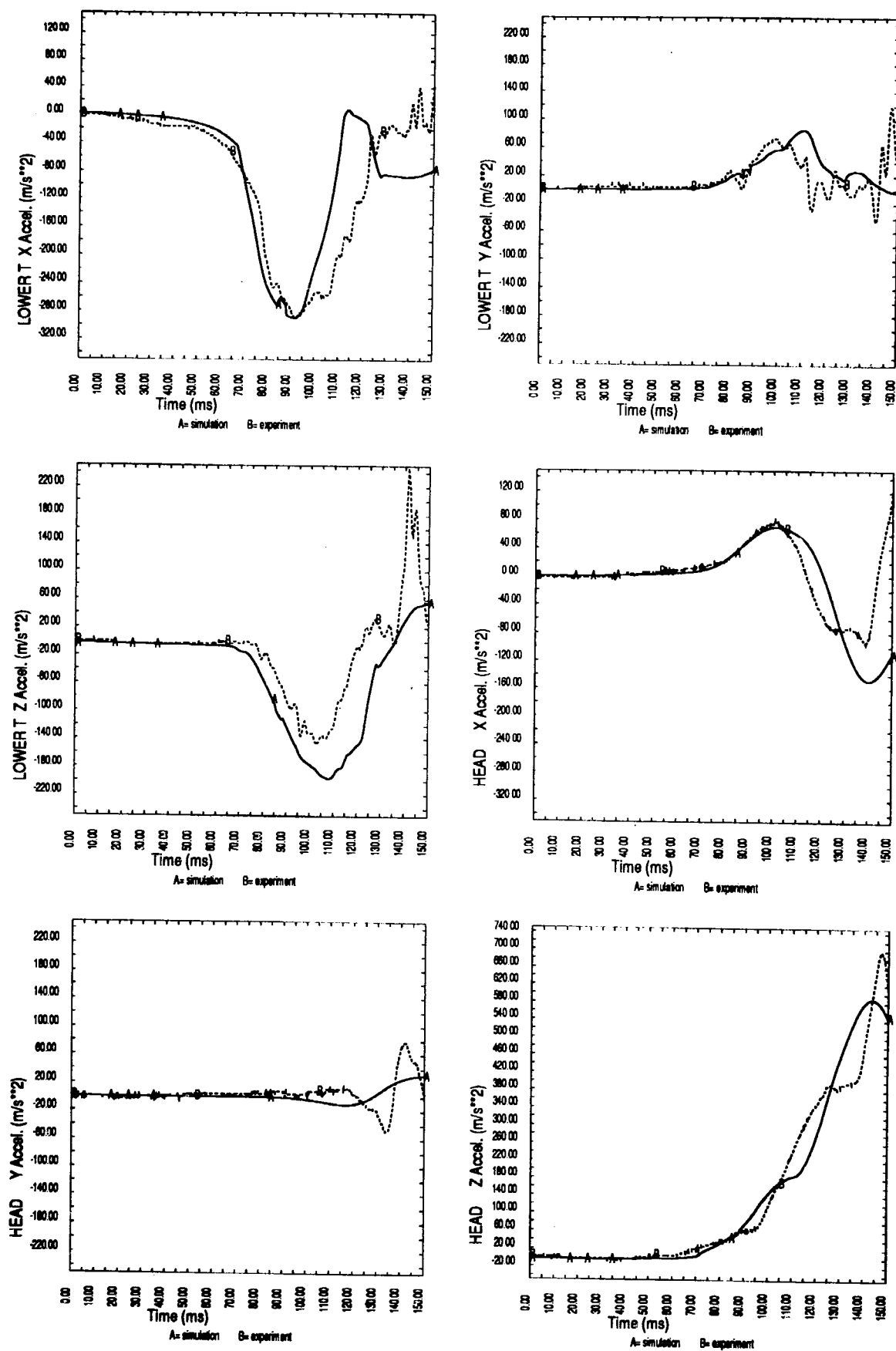

Fig. 13 Comparison between simulated and experimental accelerations for the Hybrid II dummy.



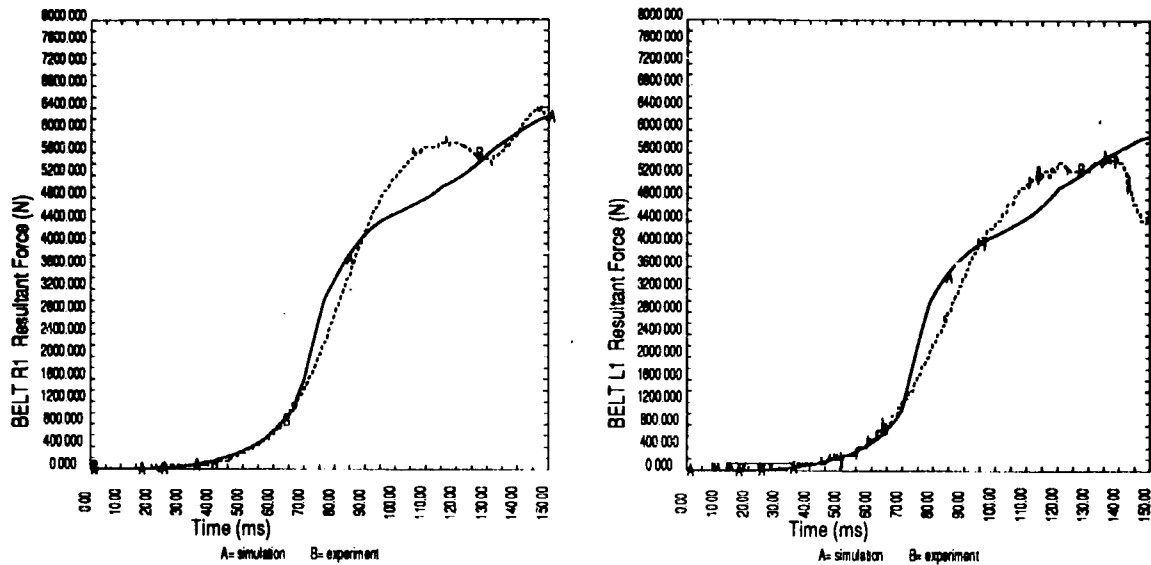

Fig. 14 Comparison between simulated and experimental forces in the belt restraining the Hybrid II dummy.

however, is always a complicating factor in this. For energy absorbing constructions often additional material is required, a strong reaction surface or structure is often desirable as well. A strong floor structure for example is an important starting condition for improving passenger safety on-board of civil aircraft. Another step could be to adjust the seat breakover stiffness, to incorporate an energy absorbing structure in the back of the lower end of the seat back and to cover hard parts which could interact with the occupant lower extremities with a padding. Special attention should be paid to passengers facing a bulkhead or galley, flight attendant (rearward facing) seats, pilot interaction with the environment, on-board child seats and equipment restraints.

From the research presented it can be learned that the current MADYMO version is suitable for simulating aircraft seat and passenger response during an actual crash or standard dynamic seat test. Since no seat structural deformation of importance was observed after the dynamic seat test presented here and no pre-deformed state for the seat legs was initiated (as prescribed in FAR Part 25) to start with, it was decided to model the lower part of the seat as a rigid body. When there is a predominant impact load component in the vertical direction, as in the "14 G dynamic seat test", a considerable deformation of the seat front tube and/or seat legs is likely to occur. In the latter case the lower part of the seat can be modelled with several rigid elements interconnected by joints. For this purpose the stiffness properties of structure components have to be translated into joint properties. The same holds for a pre-deformed state of the seat legs. Figure 15 illustrates a possible set-up for a deformable seat model, including four different joint types. Figure 16 shows another example of this so-called lumped mass modelling technique, a model of the side-structure of a passenger car. This model was used to evaluate the effect of vehicle modifications on the injuries assessed by the EUROSID-1 dummy sitting in the car [17].

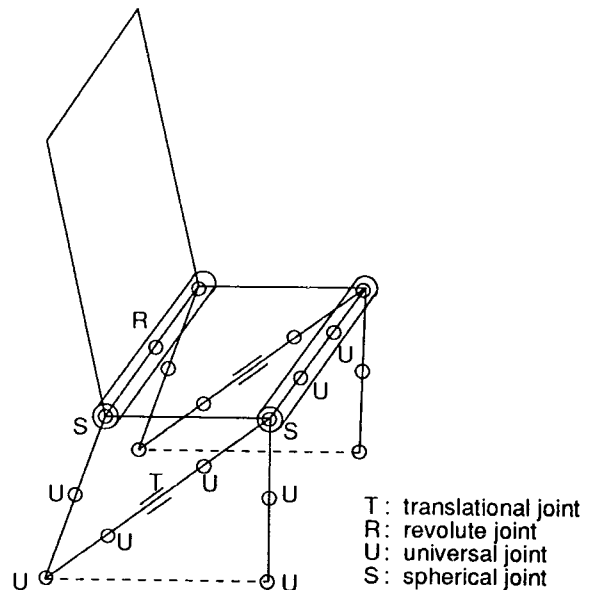

Fig. 15 Possible MADYMO model set-up for a deformable aircraft seat.

Instead of the lumped mass approach for representation of structural deformations, a finite element model can be used. This approach has the advantage that deforming structures can be analysed more in detail, a disadvantage obviously is the fact that input file generation as well as the calculation itself take more time. So, parametric studies become more laborious. Future developments in both the multibody and finite element part of MADYMO are directed to offer the user an optimal analysis tool in this respect.

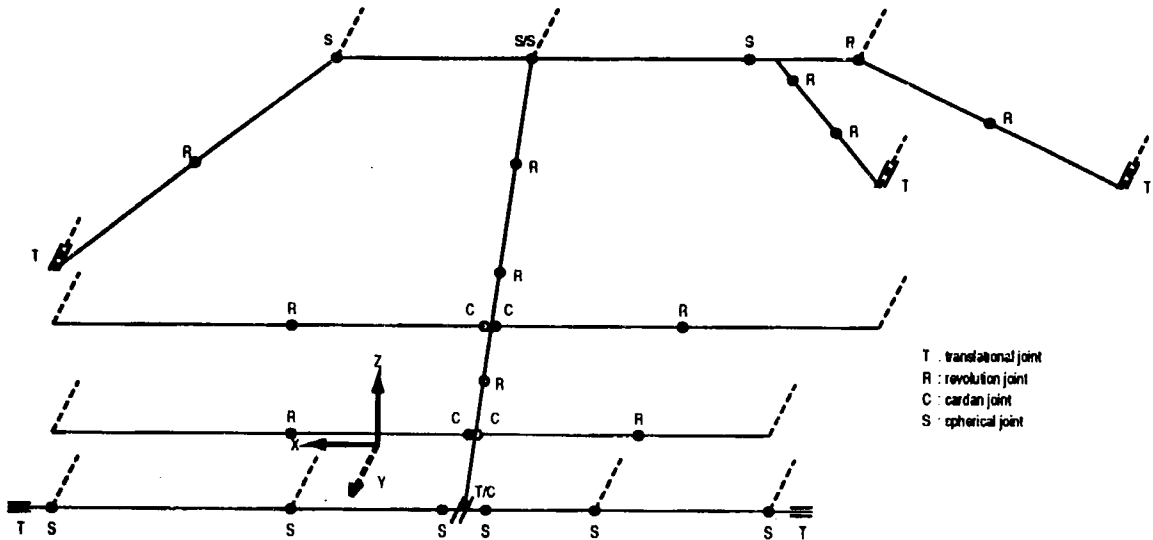

Fig. 16 MADYMO representation of the side-structure of a passenger car.

#### REFERENCES

- I. Kaleps - Prediction of whole-body response to impact forces in flight environment; AGARD Conference proceedings no. 253, Paris, 1978.
- J. Wismans and J.A. Griffioen - MADYMO Crash Victim Simulations: A Flight Safety Application; 66<sup>th</sup> Meeting of the Structures and Materials Panel of AGARD, Luxembourg, May 1-6, 1988.
- D.H. Laananen - Analysis of the Effects of Seat Parameters on Passenger Injury in Transport Aircraft Accidents; Computers in Engineering Conference, American Society of Mechanical Engineers, San Francisco, August 1-3, 1988.
- MADYMO User's Manual 3D, Version 4.3; TNO Road-Vehicles Research Institute, April 1990.
- MADYMO Databases Manual, Version 4.3; TNO Road-Vehicles Research Institute, April 1990.
- Occupant modelling in aircraft crash conditions; CAA paper 90012, HW Structures Ltd., October 1990.
- R. Hoffmann, D. Ulrich, J.B. Protard, H. Wester, N. Jähn and T. Scharnhorst - Finite Element Analysis of Occupant Restraint System Interaction with PAM-CRASH; 34<sup>th</sup> Stapp Car Crash Conference, paper no. 902325, Orlando, November 4-7, 1990.
- J.J. Nieboer, J. Wismans and P.J.A. de Coö - Airbag Modelling Techniques; 34<sup>th</sup> Stapp Car Crash Conference, paper no. 902322, Orlando, November 4-7, 1990.
- M.M. Sadeghi and A.C. Walton - The Crash Reconstruction of the G-OMBE Accident (8/1/89) by Computer Simulation; The M1 Kegworth Air Accident Seminar, I Mech E, London, January 8, 1991.
- R. Haider - The Use of Computer Simulation to Determine the Injury Mechanisms in the Kegworth Air Crash; The M1 Kegworth Air Accident Seminar, I Mech E, London, January 8, 1991.
- N.I.C. Rock - Injury Prevention through Occupant Analysis of the Kegworth Air Crash; The M1 Kegworth Air Accident Seminar; I Mech E, London, January 8, 1991.
- H.A. Lupker, P.J.A. de Coö, J.J. Nieboer and J. Wismans - Advances in MADYMO Crash Simulations; SAE International Congress & Exposition, paper no. 910879, Detroit, February 25-March 1, 1991.
- KRASH Users' Seminar proceedings; DLR Stuttgart, June 3-5, 1991.
- D.H. Laananen - Analysis of Aircraft Seats and Restraint Systems using Programs SOMLA/SOMTA; KRASH Users' Seminar proceedings, DLR Stuttgart, June 3-5, 1991.
- H.A. Lupker, H.B. Helleman, E. Fraterman and J. Wismans - The MADYMO Finite Element Airbag Model; 13<sup>th</sup> International Technical Conference on Experimental Safety Vehicles, paper no. 91-S9-O-23, Paris, November 4-7, 1991.
- J.J. Nieboer, A.P. Goudswaard, J. Wismans, E.G. Janssen and A.C.M. Versmissen - Computer Simulation of Motorcycle Airbag Systems; 13<sup>th</sup> International Technical Conference on Experimental Safety Vehicles, paper no. 91-S3-O-02, Paris, November 4-7, 1991.
- P.J.A. de Coö, E.G. Janssen, A.P. Goudswaard and J. Wismans - Simulation Model for Vehicle Performance Improvement in Lateral Collisions; 13<sup>th</sup> International Technical Conference on Experimental Safety Vehicles, paper no. 91-S5-O-25, Paris, November 4-7, 1991.
- W.E.M. Bruijs, P.J.A. de Coö, R.J. Ashmore and A.R. Giles - Airbag Simulations with the MADYMO FEM Module; SAE International Congress & Exposition, paper no. 920121, Detroit, February 24-28, 1992.