

Medical robotics

Citation for published version (APA):

Willems, C. H. M. P. (2003). *Medical robotics: haptic feedback for biorobotics*. (DCT rapporten; Vol. 2003.095). Technische Universiteit Eindhoven.

Document status and date:

Published: 01/01/2003

Document Version:

Publisher's PDF, also known as Version of Record (includes final page, issue and volume numbers)

Please check the document version of this publication:

- A submitted manuscript is the version of the article upon submission and before peer-review. There can be important differences between the submitted version and the official published version of record. People interested in the research are advised to contact the author for the final version of the publication, or visit the DOI to the publisher's website.
- The final author version and the galley proof are versions of the publication after peer review.
- The final published version features the final layout of the paper including the volume, issue and page numbers.

[Link to publication](#)

General rights

Copyright and moral rights for the publications made accessible in the public portal are retained by the authors and/or other copyright owners and it is a condition of accessing publications that users recognise and abide by the legal requirements associated with these rights.

- Users may download and print one copy of any publication from the public portal for the purpose of private study or research.
- You may not further distribute the material or use it for any profit-making activity or commercial gain
- You may freely distribute the URL identifying the publication in the public portal.

If the publication is distributed under the terms of Article 25fa of the Dutch Copyright Act, indicated by the "Taverne" license above, please follow below link for the End User Agreement:

www.tue.nl/taverne

Take down policy

If you believe that this document breaches copyright please contact us at:

openaccess@tue.nl

providing details and we will investigate your claim.

Medical Robotics

Haptic feedback for biorobotics

First traineeship

C.H.M.P. Willems
DCT 2003.95



Robotic Revolution - Device works wonder in
prostate cancer surgery.
New York Daily News [read more](#)

Supervising:

Prof. Dr. Ir. M. Steinbuch
Dr. Ir. I.M.M. Lammerts

Coaching:

M. Franken
A.F. Rovers

Eindhoven University of Technology
Department of Mechanical Engineering
Dynamics and Control Technology Group

Contents

1 Introduction	1
2 Experimental setup of the Master/slave system	3
2.1 Control strategies	3
2.2 Master/slave system	4
2.3 Experimental master system	5
2.4 Experimental slave system	6
3 Controller design	7
3.1 KFF	7
3.2 Calibration	8
3.3 Control scheme	14
4 Experimental results	15
5 Conclusions & Recommendations	17
Bibliography	18

Abstract

Although Minimal Invasive Surgery (M.I.S.) by means of robotics has many advantages for both the surgeon and the patient, it also has some disadvantages for the surgeon and commercially available medical robot systems nowadays are relatively huge and expensive. One of the main disadvantages for the surgeon is the total lack of haptic feedback in the current robotic systems.

The objective of this internship is the coupling of two separate experimental systems, a master and a slave system, in a way that the master controls the movement of the slave and the delivered torque at the slave side is fed back to the master. This kind of control mechanism is called KFF (Kinesthetic Force Feedback).

In order to keep the slave system lighter, more compact and cheaper than current slave systems, it is being actuated by means of a S.M.A. (Shape Memory Alloy) wire and a spring. The delivered torque at the slave side is fed back to the operator (at the master side) by means of a DC-motor, hence realizing some kind of haptic feedback.

The drawback of using an SMA wire as an actuator is that it shows nonlinear behaviour and has different deformation trajectories when heated or cooled. Therefore, an on/off switch has been used to control the movement of the slave, switching the controller on when the forceps need to be closed and off when they need to be opened (with the help of the spring).

The slave system used in this experimental setup, in combination with the on/off switch controller, worked well up to a frequency of 0.1 Hz. At higher frequencies of movement, the slave was unable to follow the movement of the master, especially at small opening angles of the forceps.

Therefore the slave design needs to be altered in order to increase its speed: The main problem is the slowness in opening the forceps, which in this case has been done by means of a spring. By actively opening the forceps of the slave, for example by another SMA wire, the opening and closing speed of the forceps will be equal. To further increase the speed of the forceps, an active cooling system can be incorporated in the slave system. The other problem is the slowness of the slave at small opening angles. This is because the SMA wire is at the limit of its performance. This problem can be overcome by using longer/bigger SMA wires.

The advantage of using an on/off switch in the KFF control scheme is its relative simple implementation, without the need to tune control parameters. However, a drawback of using an on/off switch is that the force applied, by the forceps, to an incompressible material can't be dosed. The switch is either on or off and hence, the actuator is always performing at its peak performance. Therefore, by determining the SMA properties, a proportional controller can be made that can be used in stead of the on/off switch. This way the force applied in the slave manipulator can be dosed. Nevertheless, a drawback of using a proportional controller is that it will make the slave even slower.

The KFF scheme seems to be rather effective, but unfortunately it doesn't allow the operator to feel when the forceps can not close any further. This happens when the material can't be compressed any further, and then the operator still has to rely on visual feedback. This problem can be overcome by implementing another control strategy, such as PERR or PERR+.

Chapter 1

Introduction

In regular surgery considerable trauma to the tissue is made, which results in long hospital stays. In some cases, MIS (minimal invasive surgery) is a good alternative. These surgical interventions are being conducted by means of lean tools, called manipulators (see figure 3.1), and a camera.

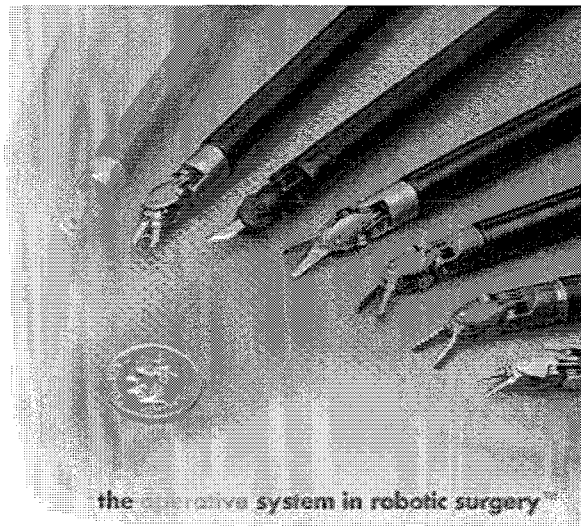

Figure 1.1: Manipulators

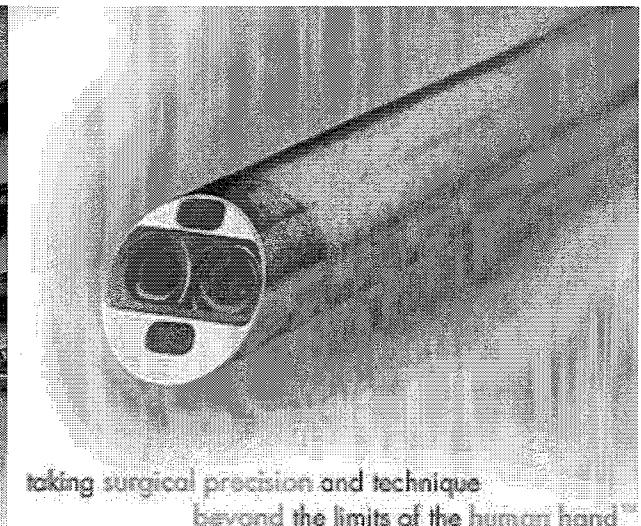

Figure 1.2: 3D Camera system

To insert these tools into the body only small incisions have to be made. This results in less trauma to the patients' tissue. Therefore, the hospital stays are shorter and there is less inconvenience, in terms of rehabilitation, for the patient. Overall, this means there are lower costs for the hospital and the patient can go back to work sooner [1].

The surgeons' job however becomes more inconvenient, since he/she must rely on the 2D image of the camera and hence, no longer has a 3D-view of the area. Furthermore the movements of the surgeon are restricted, because of the few degrees of freedom at his/her disposal, which are inverted with respect to the movements inside the body, and the magnitudes of these movements depend on how deep the tools are inserted.

The first inconvenience, with respect to the restricted view, has been overcome by the use of two cameras instead of one, see figure 1.2. The other problems can be overcome by means of robotics. However, some other disadvantages occur in current robotic systems. First of all, they are relatively huge and expensive, but furthermore they also lack haptic feedback. Without haptic/force feedback, the surgeon cannot determine the force he/she is exerting on the tissue, although this is very important to be able to perform surgery appropriately. The surgeon then can only rely on the visual feedback to get some information about the force exerted to the human tissue [4].

The objective of this internship is to couple an existing master system (with one degree of freedom) to an existing slave system (also with one degree of freedom) and to accomplish haptic feedback on this experimental setup. The slave manipulator is being actuated by means of an SMA (shape memory alloy) wire to keep the slave small, light and inexpensive.

In chapter 2 the possible control strategies will be elaborated and a closer look will be taken at the master and slave system. Next a control strategy will be chosen and implemented in Matlab, but before this can be implemented in Matlab, the system needs to be calibrated (chapter 3). Then the experimental results will be discussed in chapter 4 and after that some conclusions can be drawn and recommendations can be made for further research in this field (chapter 5).

Chapter 2

Experimental setup of the Master/slave system

Before a design can be made for the master and the slave manipulator certain things have to be taken into account, for instance:

- Which parameters have to be monitored to be able to create a position tracking system, in which the master dictates the movement of the slave?
- Which parameters have to be monitored to be able to create a force feedback structure?
- What can be used to actuate the movement of the slave and the force feedback at the master?

To be able to answer these questions, possible control strategies have to be elaborated. For more extensive information on the topics discussed in this chapter, see [2], [3], [4] and [5].

2.1 Control strategies

Three control strategies for haptic feedback in a master/slave system have been elaborated in [4] and [5]: KFF (Kinesthetic Force Feedback), PERR (Position Error) and PERR+ (Position Error and Kinesthetic Force Feedback).

- **KFF**

KFF, also called direct force feedback, is a control strategy in which the force delivered by the slave is directly fed back to the master while the master dictates the position of the slave.

- **PERR**

In this control strategy, the force exerted by the master is proportional to the position error between the master and the slave.

- **PERR+**

This control strategy is a combination of the previous two strategies.

2.2 Master/slave system

The first two questions, mentioned in the introduction of this chapter, can be answered with the help of a simple graphic scheme, see figure 2.1.

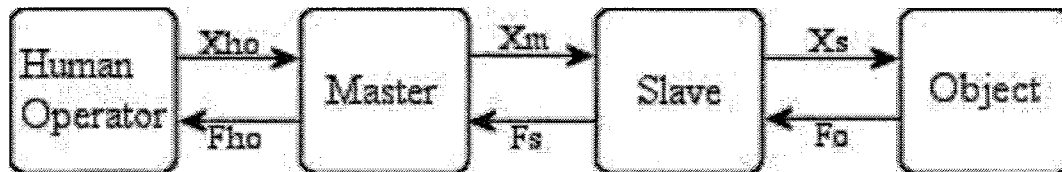

Figure 2.1: master slave system

- In order to be able to create a position tracking system, the displacement/position of both master and slave have to be known (measured or reconstructed). The difference between these two positions can be used to determine the movement the slave has to make in order to be in the same position as the master.
- In order to be able to create a direct force feedback structure, the exerted force has to be determined (measured or reconstructed [6]) at the slave. In this experimental setup, the exerted force is measured and then fed back to the master, which in turn exerts the same amount of force on the human operator.

This, in fact, enables applying all three control strategies mentioned in the previous section.

2.3 Experimental master system

The master system has to meet several system requirements. These need to be taken into account when designing the master. This has led to the design shown in figure 2.2 and 2.3 [3].

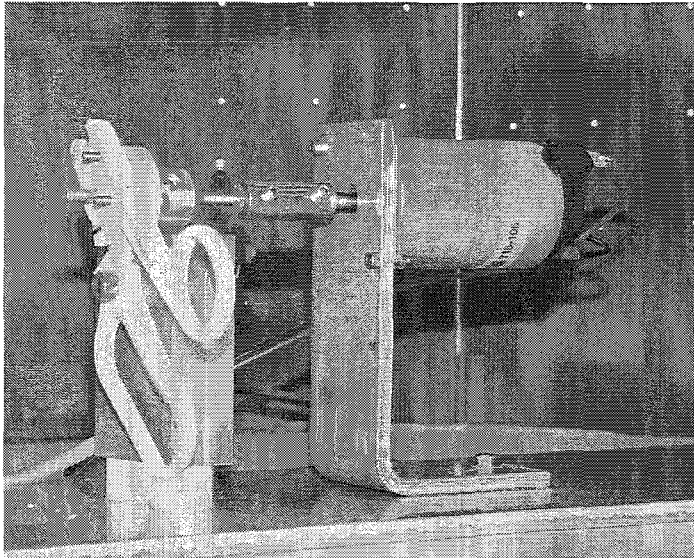

Figure 2.2: master design

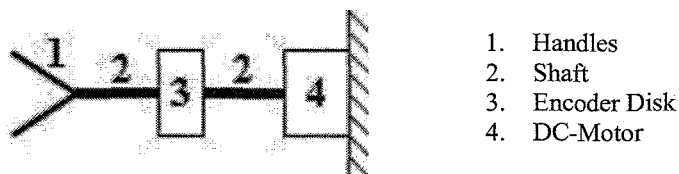

Figure 2.3: schematic representation of master design

The master consists of a set of handles, which the human operator can operate, and a shaft to which a movement sensor and a DC-motor are attached. The movement sensor consists of a two channel optical incremental encoder in combination with a 500 counter encoder disk. The encoder disk is attached to the shaft in order to determine the movement of the handles and the DC-motor is used to deliver the desired torque to the handles.

2.4 Experimental slave system

The slave also has to meet several system requirements accordingly, the slave has been designed as shown in figure 2.4 and 2.5 [2].



Figure 2.4: Slave design

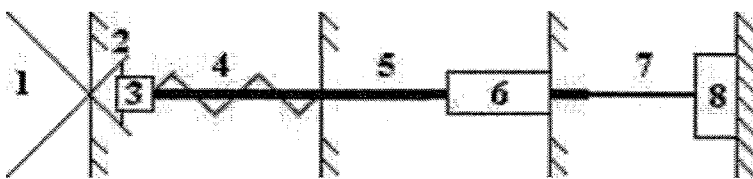

1. Forceps
2. Motion mechanism
3. Drive rod
4. Spring
5. Stiff wire
6. LVDT
7. Nitinol wire
8. Load cell

Figure 2.5: schematic representation of slave design

The slave consists of a set of forceps that can be used to grab an object. These forceps are opened and closed by means of the motion mechanism which is connected to the drive rod. One SMA wire (i.e. nitinol) and one spring are used to actuate the movement of the drive rod. This SMA (Shape Memory Alloy) wire contracts when it is heated closing the forceps. The grasping force can be increased with the help of more SMA wires in stead of one, therefore two SMA wires are used in this setup. These SMA wires can be heated by allowing a certain current to go through them. The reason SMA wires are used as an actuator is that they are relatively cheap, small and still powerful.

The LVDT (Linear Variable Differential Transformer) is used as a position sensor, which can detect the position of the stiff wire. At the right end of the slave (see figure 2.4) a load cell is fitted in order to determine the force the SMA wires exert on the system and thus the grasped object.

Chapter 3

Controller design

The three control strategies mentioned in chapter 2 can be used to make a controller design. In this chapter, a closer look will be taken at how to implement the KFF controller strategy. This choice was made because of the recommendations in [5].

3.1 KFF

KFF is a simple control strategy where the master dictates the position of the slave and the force exerted at the slave is directly fed back to the master, see figure 3.1.

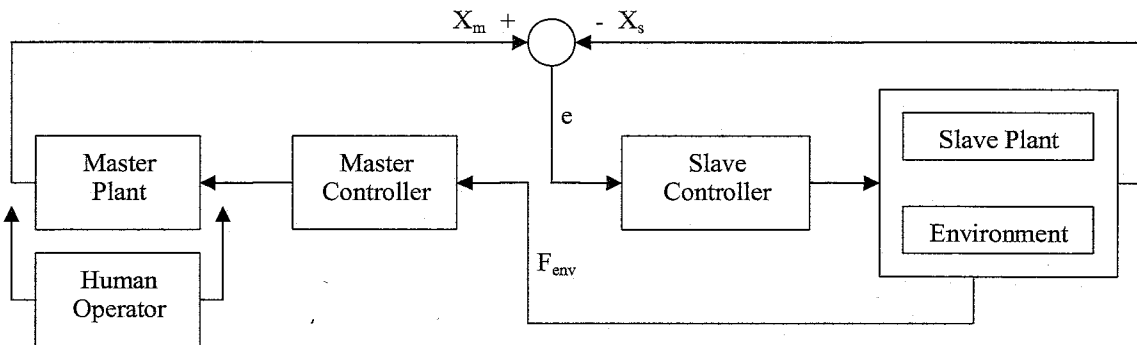

- X_m : position master
- X_s : position slave
- e : position error
- F_{env} : force environment

Figure 3.1: KFF scheme

This scheme can be implemented in Matlabs' simulink toolbox. This toolbox can be used in real-time experiments and uses a simple graphic interface. But before it can be implemented, the system needs to be calibrated.

3.2 Calibration

The system consists of several measuring devices, a dc-motor and a SMA wire, which all need to be calibrated in order to make the experimental setup operational.

For more information on how the equations and variables in this paragraph were determined, see [2] and [3].

- **Encoder Disk**

The encoder disk, used on the master as a position sensor, consists of a two channel optical incremental encoder and a 500 counter encoder disk. This results in 2000 counts per 2π rad and thus has an accuracy of 0.0031rad.

- **SMA Wire**

SMA wires show nonlinear behaviour and have a different deformation trajectory when heated/cooled, see figure 3.2. Because it is difficult to determine the behaviour of the wires and to implement this in simulink, the choice was made to actuate them by means of an on/off switch. When the switch is on, 0.8 Ampere is led trough the wire and the forceps will close then. When the switch is off, no current is led trough the wire and the spring then forces the forceps to open.

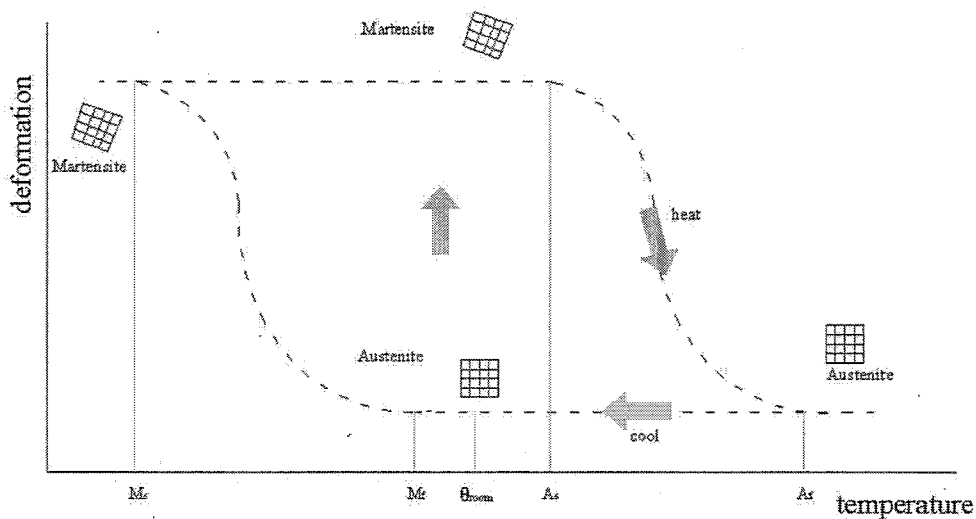

Figure 3.2: SMA deformation curve

LVDT/Position Forceps

The position sensor that is being used on the slave is a LVDT. This device sends out a voltage that is linearly dependent on the displacement of its core. Therefore this device can simply be calibrated by moving the core and registering the voltage that is send out, see figure 3.3. The solid curve in this figure consist of the measured values and the dashed curve $(\text{Position (cm)} = 0.0688 * \text{LVDT (V)} + 12.2859)$ has been fitted using the least squares method:

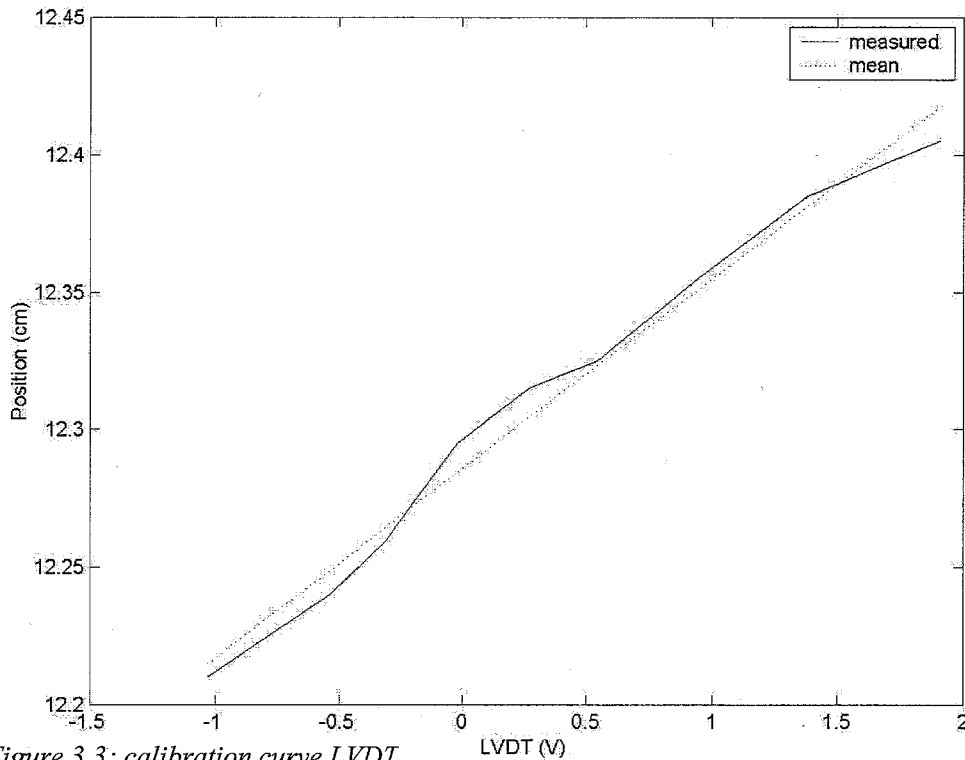

Figure 3.3: calibration curve LVDT

Hence, the position of the core can now be estimated. This position is needed to calculate the position of the forceps.

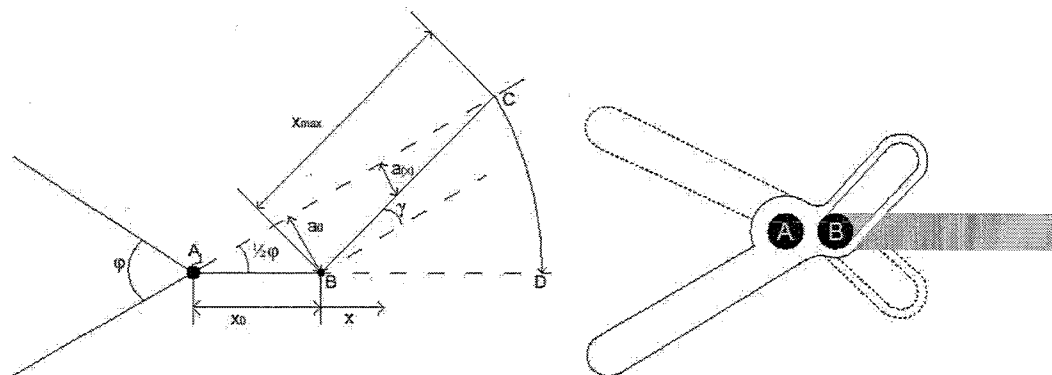

Figure 3.4: Forceps mechanism

In figure 3.4, point A is a fixed point in space. The dive rod can move between points B and D through a slot, in this way forcing the forceps to open or to close. This motion can be described with equation 3.1:

$$\varphi(x) = 2 \arcsin \left(\frac{x_0 \sin\left(\frac{1}{2} \varphi_{\max}\right) - x \sin(\gamma)}{x + x_0} \right) \quad (\text{equation 3.1})$$

Where:

Parameter	value	unit
x_{\max}	1.8	mm
x_0	2.2	mm
φ_{\max}	53	°
γ	33	°

Table 3.1: forceps parameters

- **Load Cell/Torque Forceps**

The voltage the load cell sends out is linearly dependent on the force that is exerted. Therefore the load cell can be calibrated in a similar fashion as the LVDT, only now several loads have to be connected to the load cell, see figure 3.5. The equation for the mean force curve is: Force (N) = -73.7 * LoadCell (V) + 1.7.

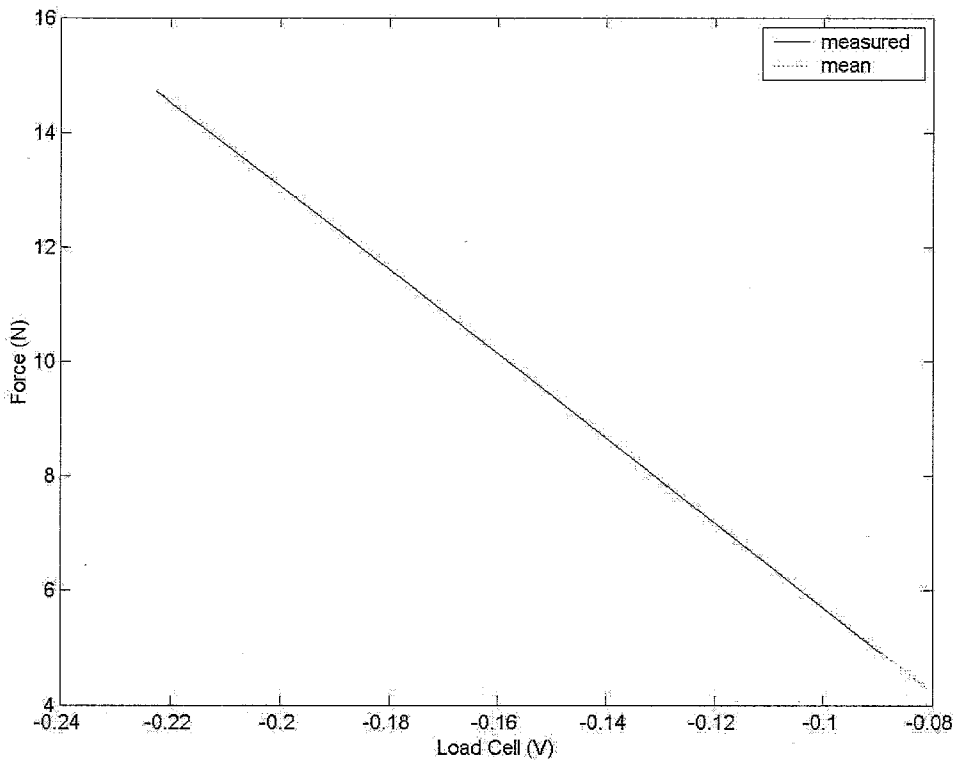

Figure 3.5: calibration curve load cell

The force delivered by the forceps is measured at the other end of the slave system, hence including several system mechanisms, like the spring. A correction for these mechanisms is needed to be able to determine the actual force the drive rod is delivering.

The force has been measured at several positions of the drive rod: in figure 3.6, the position is plotted against the measured force. The offset force can easily be determined. By obtaining the slope of the curve(s) at the centre, the spring constant can be determined. The Coulomb friction can be acquired by determining the distance between the two parallel curves near the center.

Parameter	value	unit
k	$2.4 \cdot 10^3$	N/m
F_c	0.35	N
F_o	2.15	N

Table 3.2: slave system parameters

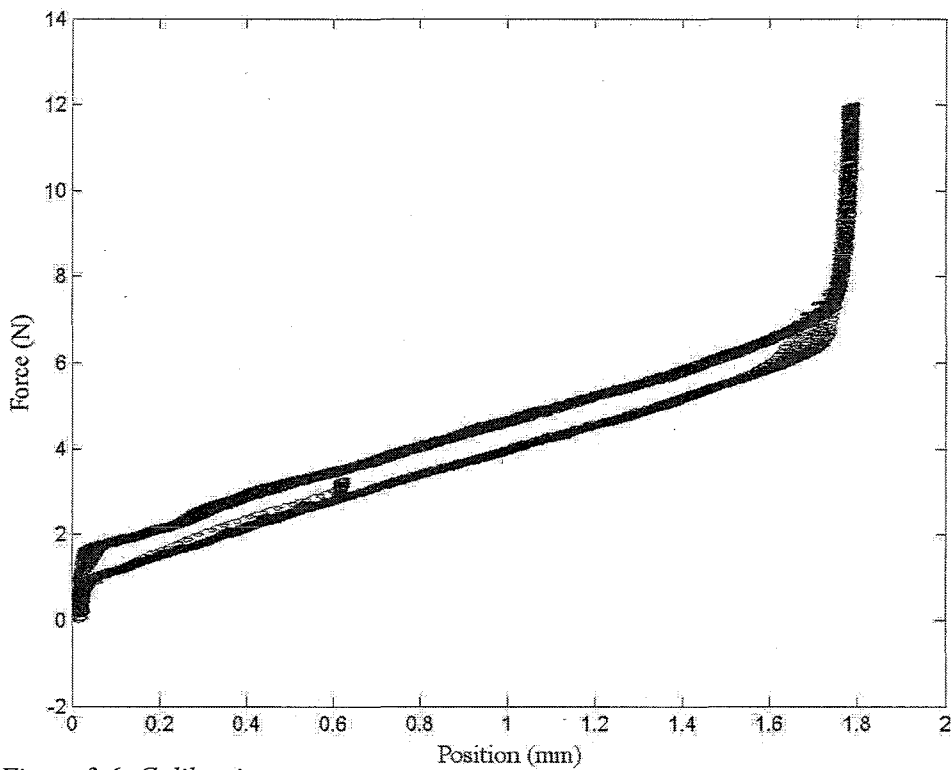

Figure 3.6: Calibration curve system

$$F_m = F_{measured} - F_o - k * x - F_c * sign(x) \quad (\text{equation 3.2})$$

By means of equation 3.2 corrections have been made to determine the actual force the drive rod is delivering. This force however is not the same as the force delivered by the forceps, as can be seen in figure 3.7.

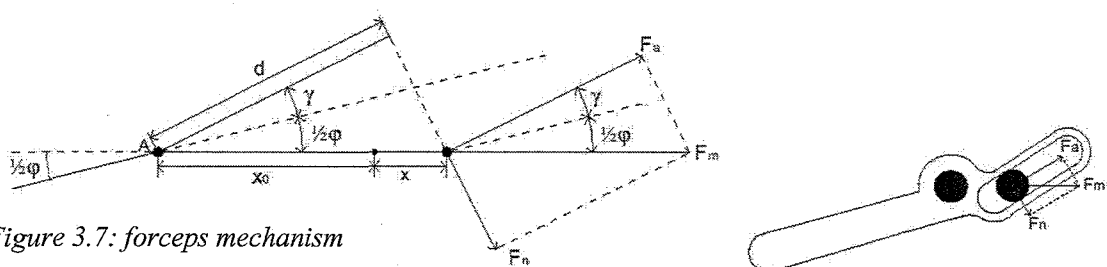

Figure 3.7: forceps mechanism

By means of equation 3.3 the delivered torque can be calculated

$$T_g = \frac{1}{2} F_m (x_0 + x) \sin(\varphi(x) + 2\gamma) \quad (\text{equation 3.3})$$

- **DC-Motor**

The DC-Motor has linear torque characteristics, as can be seen in figure 3.8: it delivers a torque of 0.033 Nm per Ampere.

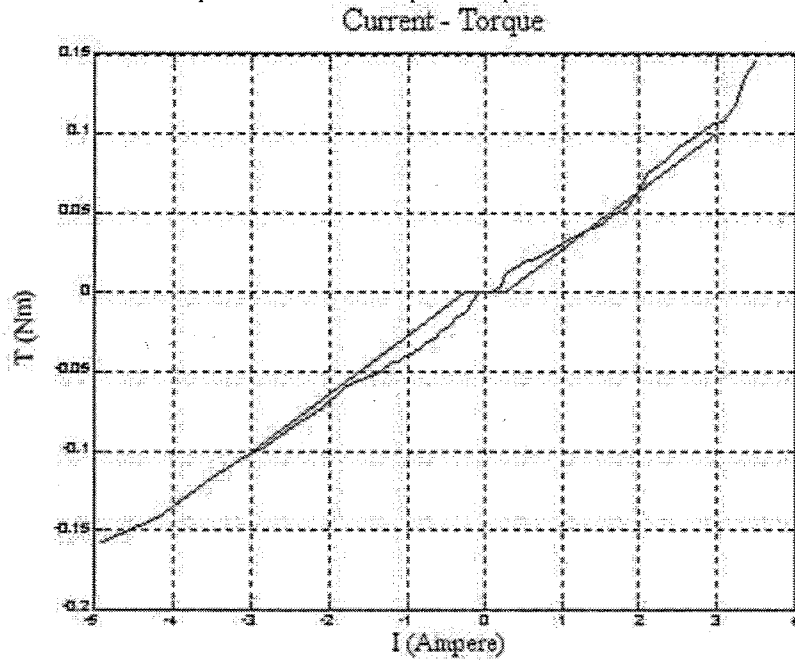

Figure 3.8: calibration curve DC-Motor

- **Current Amplifier**

To be able to actuate the DC-Motor and the SMA wires a voltage amplifier (-4V/V) and a current amplifier (0.7 A/V, see figure 3.9) need to be used.

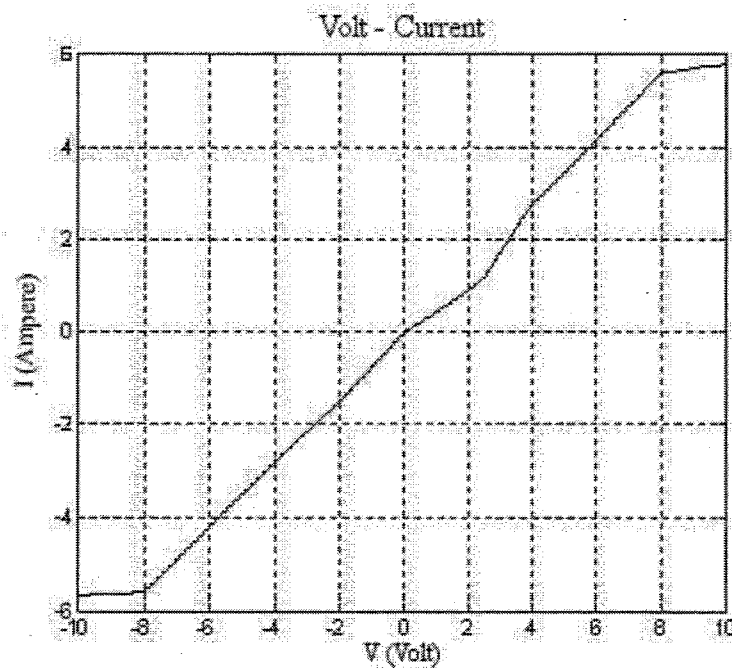

Figure 3.9: calibration curve current amplifier

3.3 Control scheme

Because of all the calibration parameters and equations, the simulink control scheme (figure 3.10) looks different but has the same functionality as the KFF control scheme shown in paragraph 3.1. The solid block in this control scheme represents the TUEDACs. This device is used to control and monitor all the devices that are incorporated in the experimental setup. Two output channels, dac 0 and dac1, and three input channels, adc0 adc1 and enc1, will be used. Output channel dac 0 is used for controlling the DC-motor and output channel dac 1 for actuating the SMA wires. The input channels, adc0 adc1 and enc1, are used for the Load Cell, the LVDT and the encoder disk respectively.

- Slave controller:** First of all, the readouts of the encoder disc (enc1) and the LVDT (adc1) need to be converted to determine the opening angle (rad) of the master respectively the slave. The difference in these two angles (angle deviation) will be used to determine if the on/off controller switch (sign+saturation1+ampere to volt) is in the on or off state. This on/off signal is then fed back to the SMA wires (dac1), allowing them to open or close the forceps, correcting the angle deviation.
- Master controller:** The readouts of the load cell (adc0) need to be converted (volt to N) to determine the force the SMA wire exerts on the system. This signal contains a lot of high frequency noise, and is therefore led through a low pass filter (low-pass). The measured force then needs to be corrected for system properties like the offset force (offsetforce (N)), the spring (force spring (N)) and the coulomb friction (coulomb friction (N)). The resulting signal is the force the drive rod is delivering, which is then converted (F_{cn}) to the torque the forceps are delivering. After scaling this torque and taking the amplifiers in account the signal can be fed back to the DC-motor (dac0).

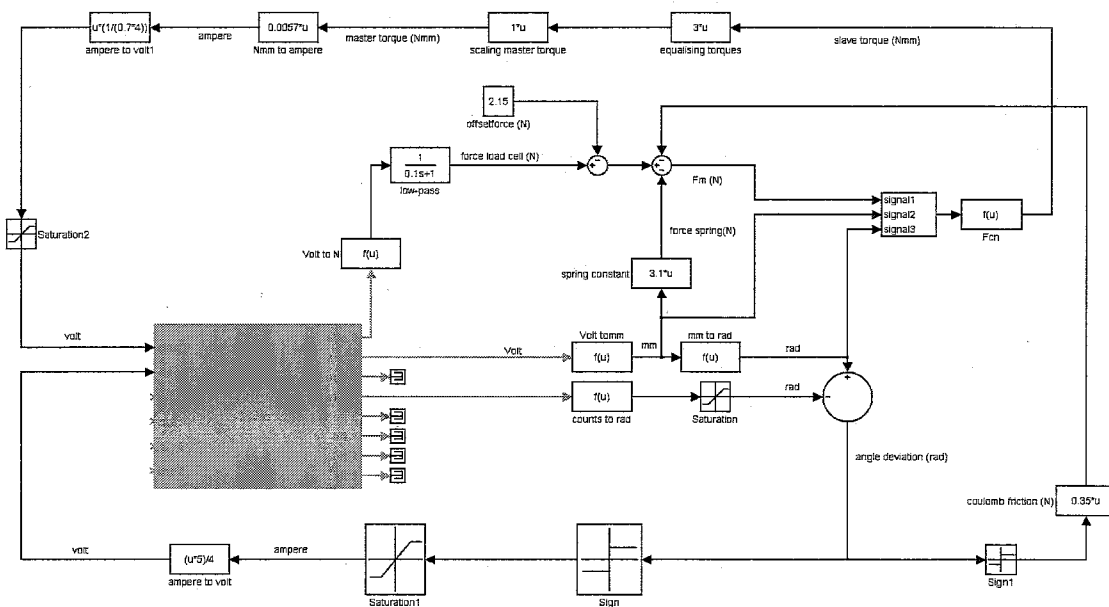

Figure 3.10: Simulink Model

Chapter 4

Experimental results

A simulation was done with the simulink control scheme shown in the previous chapter. At the start of the simulation ($t=0$) the handles of the master controller are being moved at a frequency of 0.001 Hz, at $t=100$ the handles of the master controller move at a frequency of 0.1 Hz.

In figure 4.1 only the data from the position sensors is plotted. The green curve shows the difference in angle between the master and the slave, which is a direct indication of how well the on/off switch works. As can be seen the angle deviation is very small, this remains to be the case up to a frequency of 0.1 Hz. At higher frequencies the slave is too slow to be able to follow the motion of the master. Especially for small opening angles the slave has difficulties to follow the movements of the master at higher frequencies.

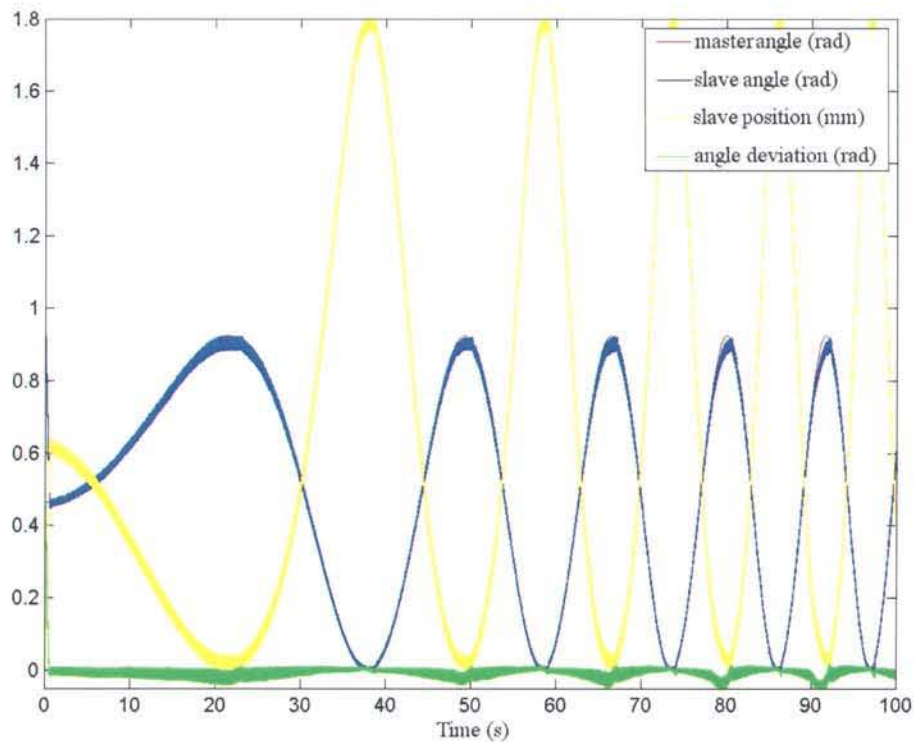

Figure 4.1: results position tracking

In figure 4.2 all acquired the data is plotted. The black curve shows the SMA actuation and the purple curve the output of the Load Cell, the rest of the data is the same as in figure 4.1. The downside is that no data can be collected from the DC-Motor. However because of the calibration one can assume with good certainty that the DC-Motor gives the same amount of torque as the forceps do.

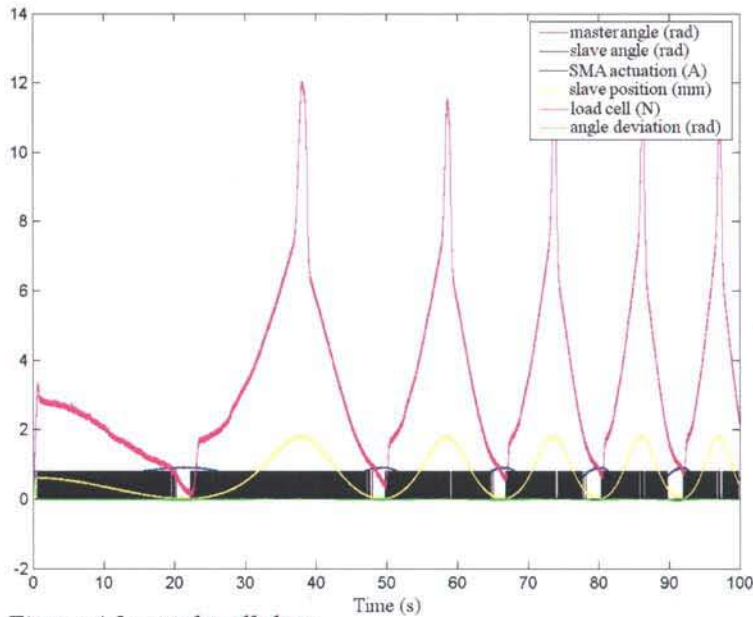

Figure 4.2: results all data

From the previously shown figures, it can be concluded that the KFF scheme with a simple on/off switch works and that no instability occurs whenever the system is well calibrated. The systems stability can also be allocated to the slowness of the actuation of the slave.

Because of the usage of an on/off switch for the actuation of the SMA wires there is no ability to dose the exerted force on incompressible materials. Another disadvantage that occurs for incompressible materials is that the fed back force stays the same even if the position error increases, in other words the surgeon can't feel that the forceps can't close any further.

Chapter 5

Conclusions & Recommendations

During this internship an experimental slave system, with an SMA wire as actuator, has been coupled to an experimental master system, with the help of a KFF control scheme. This KFF control scheme uses an on/off switch to control the SMA wire and a torque feedback structure to control the master.

Based on the results shown in chapter 4, several conclusions can be drawn and some recommendations for future studies in this field can be made:

- At high frequencies of motion [>0.1 Hz], the slave is too slow to be able to follow the movements of the master, especially at small opening angles of the slave. Therefore the slave design needs to be altered in order to increase its speed.
 - The main problem is the slowness in opening the forceps, which in this case has been done by means of a spring. By actively opening the forceps of the slave, for example by another SMA wire, the opening and closing speed of the forceps will be equal [6]. To further increase the speed of the forceps, an active cooling system can be incorporated in the slave system.
 - The other problem is the slowness of the slave at small opening angles. This is because the SMA wire is at the limit of its performance. This problem can be overcome by using longer/bigger SMA wires.
- The advantage of using an on/off switch in the KFF control scheme is its relative simple implementation, without the need to tune control parameters of the SMA wire. However, a drawback of using an on/off switch is that the force applied, by the forceps, to an incompressible material can't be dosed because of the properties of the on/off switch. The switch is either on or off and hence, the actuator is always performing at its peak performance.
 - By determining the SMA properties a proportional controller can be made, that can be used in stead of the on/off switch. In this way, the force applied in the slave manipulator can be dosed. Nevertheless, a drawback of using a proportional controller is that it will make the slave even slower.
- The KFF control scheme seems to be rather effective, but unfortunately it doesn't allow the operator to feel when the forceps can not close any further. This happens when the material can't be compressed any further, and then the operator still has to rely on visual feedback.
 - This problem can be overcome by implementing another control strategy, such as PERR or PERR+.

Bibliography

- [1] Spijker, K., Willems C.H.M.P., "*Robotchirurgie bij Prostatectomie*", M.T.A., Eindhoven University of Technology, Trimester 4.1 2002-2003
- [2] Peeters, J.M., "*A SMA Actuated Laparoscopic Forceps with Force Feedback*", Dynamics and Control Technology, Department of Mechanical Engineering, Eindhoven University of Technology, January 2002 (DCT 2002.01)
- [3] Franken, M., "*Design of a Master Manipulator for a Laparoscopic Forceps*", Dynamics and Control Technology, Department of Mechanical Engineering, Eindhoven University of Technology, February 2002 (DCT 2002.07)
- [4] Rovers, A.F., "*A Literature Study on the Present-day use of Haptic Feedback in Medical Robotics*", Dynamics and Control Technology, Department of Mechanical Engineering, Eindhoven University of Technology, September 2002 (DCT 2002.57)
- [5] Cools, S., "*Design of a Master-Slave system with Force Feedback*", Dynamics and Control Technology, Department of Mechanical Engineering, Eindhoven University of Technology, 2003 (DCT 2003.07)
- [6] Franken, M., "*Smart memory alloy actuated slave system for medical robotics, with haptic feedback.*", Dynamics and Control Technology, Department of Mechanical Engineering, Eindhoven University of Technology, 2003 (DCT 2003.50)