

## Testing and debugging subsystems of a Maglev track

**Citation for published version (APA):**

Voeten, S. J. (2005). *Testing and debugging subsystems of a Maglev track*. (DCT rapporten; Vol. 2005.150). Technische Universiteit Eindhoven.

**Document status and date:**

Published: 01/01/2005

**Document Version:**

Publisher's PDF, also known as Version of Record (includes final page, issue and volume numbers)

**Please check the document version of this publication:**

- A submitted manuscript is the version of the article upon submission and before peer-review. There can be important differences between the submitted version and the official published version of record. People interested in the research are advised to contact the author for the final version of the publication, or visit the DOI to the publisher's website.
- The final author version and the galley proof are versions of the publication after peer review.
- The final published version features the final layout of the paper including the volume, issue and page numbers.

[Link to publication](#)

**General rights**

Copyright and moral rights for the publications made accessible in the public portal are retained by the authors and/or other copyright owners and it is a condition of accessing publications that users recognise and abide by the legal requirements associated with these rights.

- Users may download and print one copy of any publication from the public portal for the purpose of private study or research.
- You may not further distribute the material or use it for any profit-making activity or commercial gain
- You may freely distribute the URL identifying the publication in the public portal.

If the publication is distributed under the terms of Article 25fa of the Dutch Copyright Act, indicated by the "Taverne" license above, please follow below link for the End User Agreement:

[www.tue.nl/taverne](http://www.tue.nl/taverne)

**Take down policy**

If you believe that this document breaches copyright please contact us at:

[openaccess@tue.nl](mailto:openaccess@tue.nl)

providing details and we will investigate your claim.

# Testing and debugging subsystems of a Maglev track

Stefan J. Voeten

October 21, 2005

# Preface

One of the parts of the educational program of electrical engineering at the Technical University of Eindhoven are the internships. For my internship I went for five and a half months to the United States. There I have worked at the Florida Institute of Technology on the MAGLEV track. This test setup originally was used by NASA to research the possibilities of the application of a magnetic launch system to reduce launching costs. My predecessor, Jeroen de Boeij, implemented a 3 DOF SMC controller which was capable of levitating the sled while it was moved forward by hand over a short distance. At the time I arrived it was no longer possible to demonstrate this controller due to a unknown malfunction of the track. This report discusses my work on the track during my internship but, it can also be used as a starters guide for new users on the track. It discusses the basic components of the track, describes simple experiments to check the components (individually and combined) and gives a basic introduction to control of the sled.

A special word of thanks is due to Hector Gutierrez for his trust, motivation and companionship. I would like to thank Prof. dr. ir. Steinbuch for giving me this opportunity and for his patience. Finally I would like to thank my parents and girlfriend for their endless support.

## **Abstract**

In this report the debugging of the MAGLEV track is treated. The separate components of the track are identified and their connections are mapped. The components are tested separately, where possible, and in groups. With the functioning of the hardware confirmed, levitation tests are performed to let the user obtain a feeling of how the sled reacts to the track. Finally P, PI and PID control is applied to levitate the sled without forward movement.

# Contents

<b>1</b>	<b>Introduction</b>	<b>3</b>
<b>2</b>	<b>Introducing the components of the MAGLEV track</b>	<b>4</b>
2.1	Linear motor . . . . .	4
2.2	Levitation components . . . . .	6
2.2.1	Sled . . . . .	7
2.2.2	TMS320C6701 . . . . .	8
2.2.3	Pulse wide modulation boards . . . . .	9
2.2.4	Labview connection . . . . .	9
2.2.5	Levitation logic board . . . . .	9
2.2.6	Levitation amplifier . . . . .	10
2.2.7	Levitation coil . . . . .	11
2.2.8	Levitation sensor board . . . . .	12
2.2.9	Laser . . . . .	13
2.2.10	Coil distribution . . . . .	13
<b>3</b>	<b>Testing the components</b>	<b>16</b>
3.1	Linear motor . . . . .	16
3.2	TMS320C6701 and levitation amplifiers . . . . .	17
3.3	Levitation sensor boards and travelled distance . . . . .	22
3.4	Levitation coil . . . . .	24
3.5	Laser . . . . .	26
3.6	Testing the control loop . . . . .	29
3.7	Testing levitation . . . . .	30
3.8	Quick startup test and check lists . . . . .	36
<b>4</b>	<b>Applying control</b>	<b>39</b>
4.1	experiments . . . . .	41
4.2	Proportional control . . . . .	42
4.3	Proportional and Integral control . . . . .	45
4.4	Proportional, Integral and Differential control . . . . .	47
<b>5</b>	<b>Wireless</b>	<b>49</b>
5.1	The first concept, not multiplexed . . . . .	49
5.2	The second concept, multiplexed . . . . .	52
<b>6</b>	<b>Proposed improvements</b>	<b>54</b>



# Chapter 1

## Introduction

This report describes my internship at the Florida Institute of Technology. Before I arrived at the FIT in August 2004 Jeroen de Boeij had been capable to move the sled a short distance forward by hand with controlled levitation. But at my arrival this was no longer possible for reasons unknown. Eventually this resulted in my internship assignment; find the error in the setup and get the MAGLEV track to function again in such a way that Jeroen's experiment could be done again.

Because the setup is very large this asked for a systematic approach. In chapter 2 all the separate components and their function are identified. Chapter 3 treats the tests done on as small subsystems of the MAGLEV track as possible to verify their functioning. In chapter 4 the control loop used for levitation is tested and in chapter 5 the actual levitating of the sled. Chapter 6 shows a very simple control algorithm that is used to levitate the sled without forward motion.

In chapter 7 a concept and implementation of a wireless connection will be treated. The purpose of this wireless connection is to remove all wires connected to the sled. The first concept is tested and leads to a second and improved concept.

Chapter 8 gives recommendations for improvements to the track. Conclusions can be found in chapter 9.

## Chapter 2

# Introducing the components of the MAGLEV track

This chapter will give a short introduction of the hardware of the MAGLEV track. Most of the descriptions will have pictures to give a new user a good idea of the system.

### 2.1 Linear motor

The linear motor moves the sled forward and is totally separated from the levitation part of the setup. It functions autonomously. Therefore little work could be done with the linear motor except for an update in the hardware and regularly checking whether all the hardware of the linear motor still functions. The electronics are divided in 24 groups. Each of them has one control PCB, one sensor board, six IGBT's and three coils. IGBT stands for Insulated Gate Bipolar Transistor. An IGBT is a high power electronic switch. Per coil two IGBT's are used. One connected to each side of the coil. Figure 2.1 shows a block scheme to show how the separate components are connected in one group. Figure 2.2 show the cabinet in which the nine power supplies are placed for the linear motor, figure 2.3 shows all the control electronics used for the linear motor and figure 2.4 show a top view of the control PCB and IGBT's. Above the white connectors at the bottom of the control PCB are two red led's. They indicate if one of the six sensors, on the sensor board, is interrupted. If the sensors are interrupted one at a time, and everything works, the led's will light up in the following order 1, 3, 5, 2, 4, 6. Led 1 and 2 are connected to coil 1, led 3 and 4 to coil 2 and so on. An uneven numbered led indicates a current through the coil in one direction and an even numbered led indicates a current the other way. To the sides of the same white connector green LEDs are placed which light up when the power is turned on.



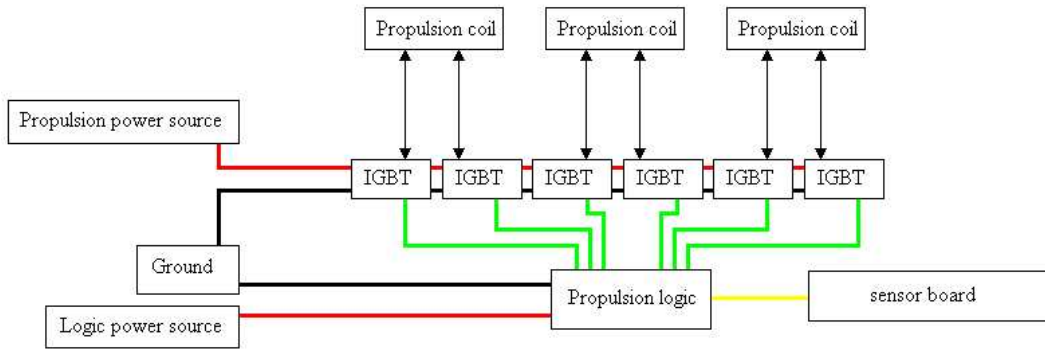

Figure 2.1: Block scheme of the linear motor



Figure 2.2: Power sources for linear motor

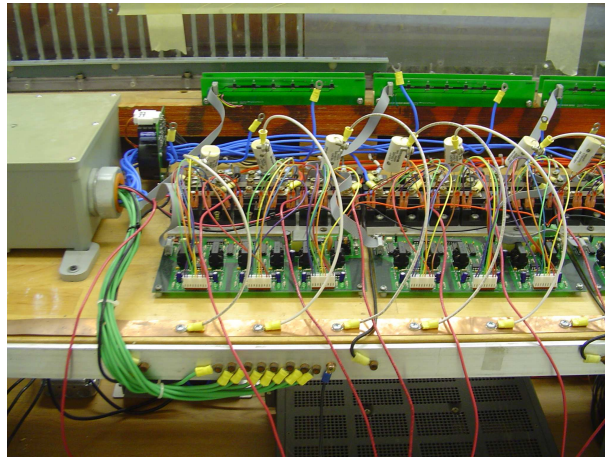

Figure 2.3: Control electronics, IGBT's and sensor boards

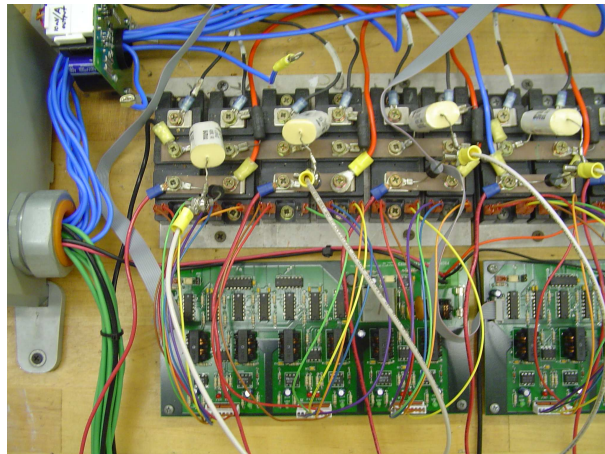

Figure 2.4: Control electronics and IGBT's

## 2.2 Levitation components

Figure 2.5 shows a block diagram of all the hardware used to control the levitation of the sled.

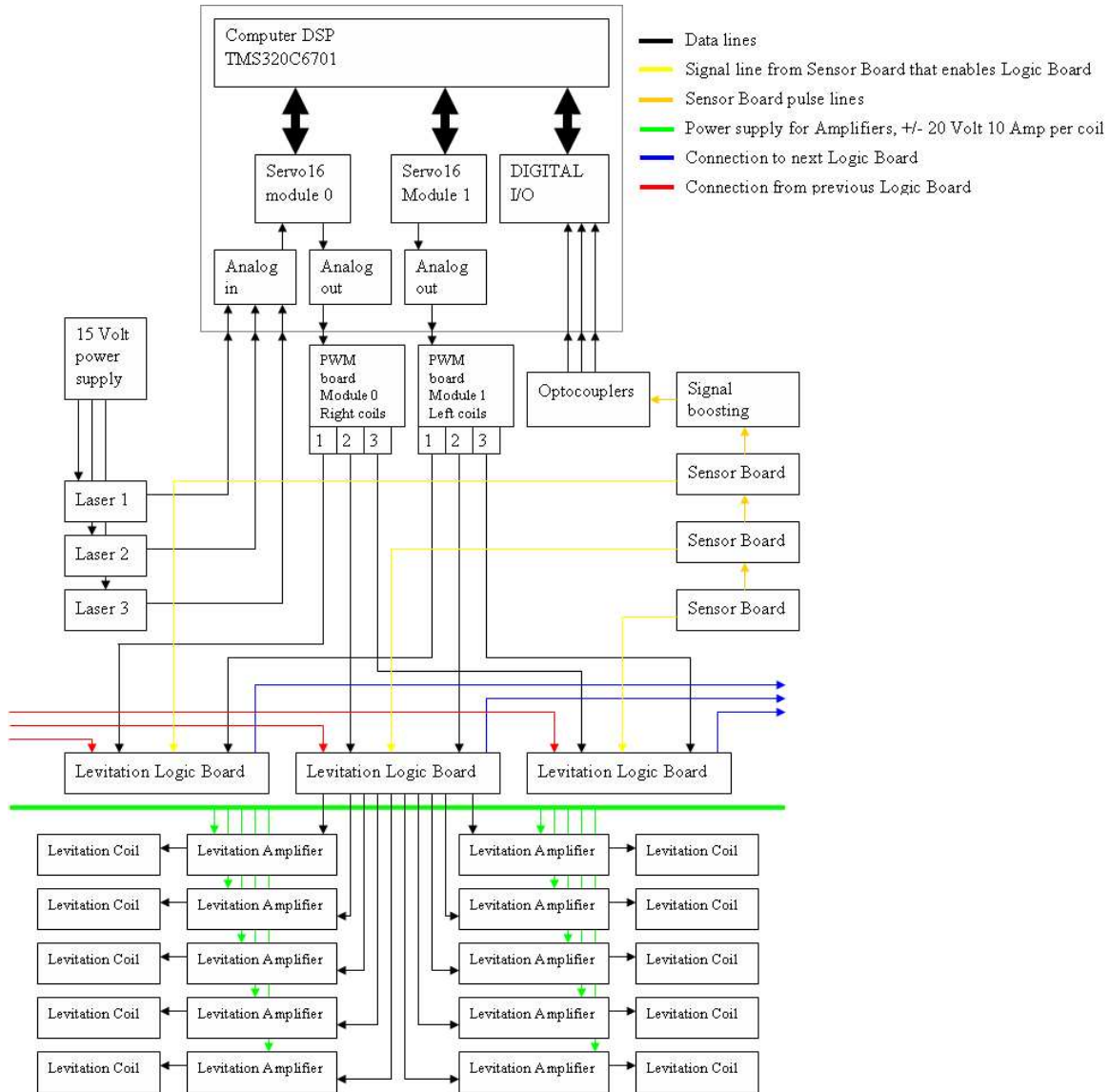

Figure 2.5: Block scheme of the levitation hardware

### 2.2.1 Sled

Figure 2.6 and figure 2.7 show the horizontal position of the front and rear of the magnets in the sled and the metal plate that slides through the sensors with respect to laser number 2. These values are given here because they play an essential role in the test and control software. The vertical dimensions are not represented in these figures.

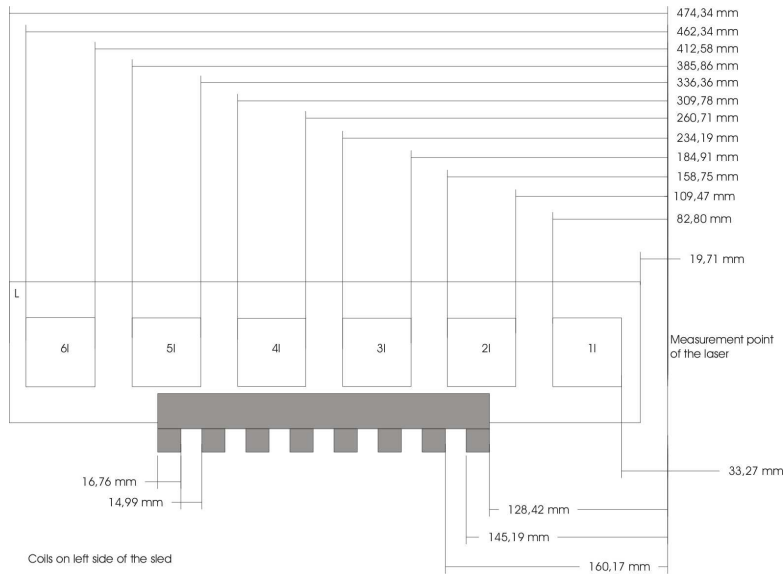

Figure 2.6: Horizontal dimensions on the left side

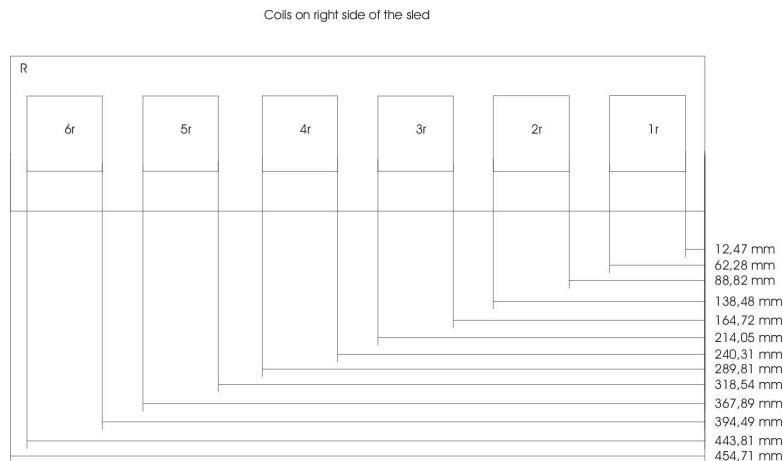

Figure 2.7: Horizontal dimensions on the right side

When we started working on the setup the configuration of the sled was as is shown in figure 2.8. Batteries, used as power supply for the lasers and unused hardware were removed. We replaced the batteries by a power source placed on the desk, which was connected to the sled by a long cable. The lasers were connected to the PC, also with long cables as in the

old situation. These changes resulted in a weight reduction of the sled and a more reliable performance of the lasers, see figure 2.9.

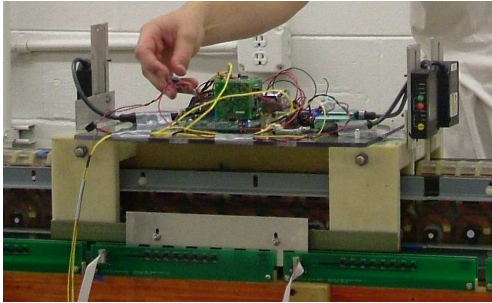

Figure 2.8: Old configuration

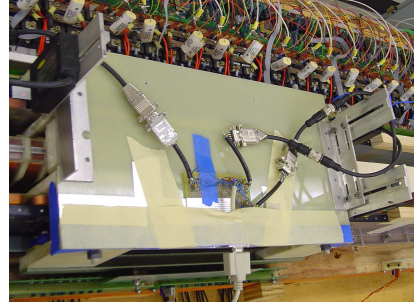

Figure 2.9: New configuration

The sled has blue rubber wheels to support it when it is not levitated, see figure 2.10. In rest, these wheels are on the lower support rail of the track. The upper support rail prevents the sled from being lifted off the track.

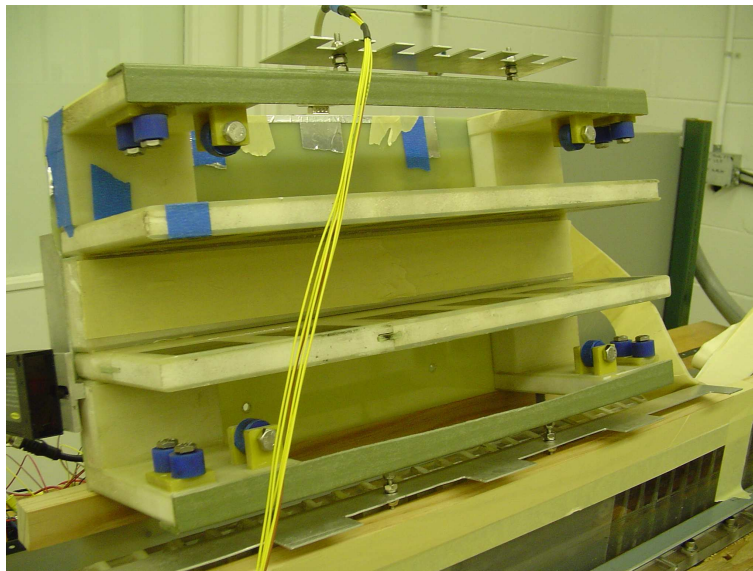

Figure 2.10: The support wheels of the sled

### 2.2.2 TMS320C6701

This digital signal processing board has two servo16 modules, module 0 and module 1. Each of them has 16 DAC channels and 16 A/D channels. The DAC channels have a precision of 16 bit, a settling time of 2 micro seconds and an output range of  $\pm 10$  Volt. For more information see the 'omnibus manual' on the cd-rom. Module 0 is connected to the coils on the right side and the lasers on the sled. Module 1 is connected to the coils on the left side.

### 2.2.3 Pulse wide modulation boards

Each of the servo16 modules is connected to a pulse wide modulation board with a flat cable. These boards convert the DSP signals to pulse wide modulated signals to reduce noise and signal deterioration due to the use of long and unshielded cables. Each of the two PWM boards has fifteen outputs, see figure 2.11. This way thirty coils can be controlled at all time to levitate the sled.

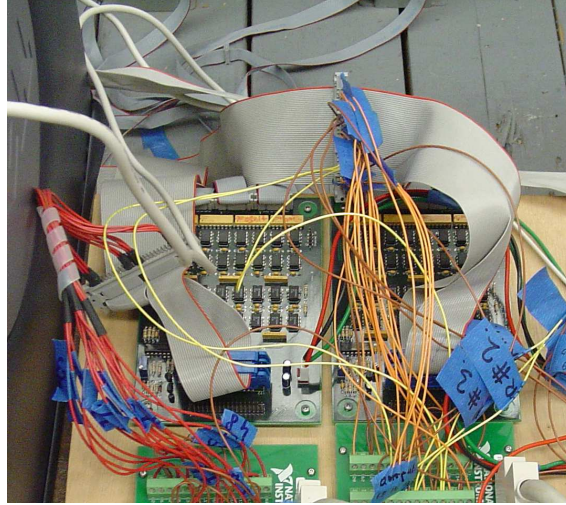

Figure 2.11: The PWM boards

### 2.2.4 Labview connection

A separate computer with two Labview cards is used to measure the outputs of the servo16 modules. Figure 2.12, figure 2.2.4 and figure 2.2.4 show how the Labview cards are connected to the servo16 outputs.

### 2.2.5 Levitation logic board

These PCB's enable the levitation amplifiers which power the levitation coils. They receive a signal from their sensor board if the metal plate on the sled interrupts one of the sensors. When this happens the control signal from the PWM board is send to the levitation amplifiers. The levitation logic boards are divided in three groups: boards number 1, 4, 7, 10, 13, 16, 19 are connected to output 0 to 4 of the two servo16 modules. Outputs 5 to 9 and 10 to 14 are connected to boards 2, 5, 8, 11, 14, 17 and 3, 6, 9, 12, 15, 18 respectively. One levitation board is connected to 10 levitation amplifiers, five for the coils on the right and five for the coils on the left side, see fig 2.14.

Each board has two green power LEDs, one for the +15 Volt and one for the -15 Volt input. The boards also have two red LEDs indicating interruption of the sensors of the board itself and of the boards in front and behind it.

The boards are 'enabled' in three situations; when one of the sensors of it's predecessor are interrupted, when it's own sensors are interrupted or when the sensors of the next board are

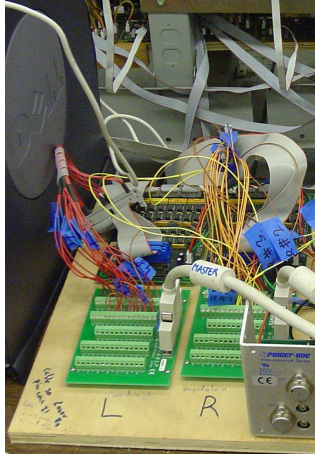

Figure 2.12: Two standard Labview connector boards were used

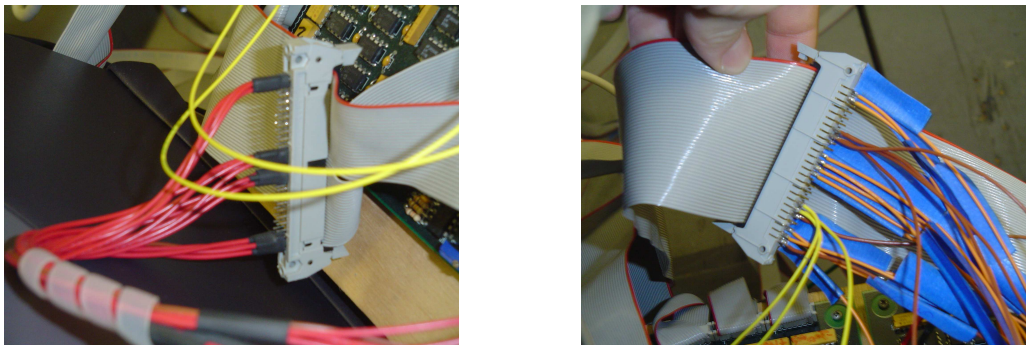

Figure 2.13: custom made cables attached to the servo16 output cable

interrupted.

For example, when sensor board number 2 is entered by the sled, levitation logic board 1, 2 and 3 will turn on. when the sled is exactly halfway sensor board 2 and 3 levitation logic board 1 will be turned off. Only 2 and 3 are on at that moment. Moving the sled a little more forward will turn 2, 3 and 4 on.

The last board in line has no boards following it to turn it off therefor a jumper is placed on the boards to indicate if it is the last board in line. If it is then, with the correct jumper setting, the board, once it is turned on by a signal from it's own or previous sensor board, will turn off the amplifiers automatically after a short time.

### 2.2.6 Levitation amplifier

These amplifiers are stacked per five behind the levitation logic boards. Each amplifier has a bandwidth of 1.6 KHz and can carry a maximum current of +/- 10 A for up to 6 seconds. This short time span is due to excessive heat build up. The 6 second period can be extended up to 10 seconds by using a ventilator. This was done during the experiments. The input signal of the amplifiers ranges from -10 to +10 Volt. One volt on the input results in a 1 Amp current on the output.

Figure 2.14: Levitation logic board with its ten amplifiers

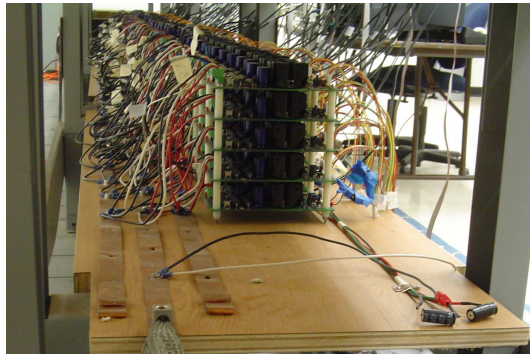

Figure 2.15: The levitation amplifiers

### 2.2.7 Levitation coil

The levitation coils have a figure eight shape. This shape has the inherent advantage that magnets passing them are being pulled to the center of the coil. When the center of the magnet is above the center of the coil the resulting force will pull the magnet down and vice versa. See tabel 2.16 for the dimensions of the coils. Figure 2.17 shows how the coils are mounted. they are placed over two tight fitting plastic pins.

The coils have the same width (5.08 cm) as the magnets in the sled, see figure 2.18 for the relative positioning of six magnets to ten coils. Only the horizontal measurement represents the real situation. In the setup the centers of the magnets are at the same height as the center of the coils. Here it is drawn this way to keep the figure clear.

Height	0.1016 (m)
Depth	0.0127 (m)
Width	0.0254 (m)
Thickness winding	0.0127 (m)
Thickness wire	0.635 (mm)
Number of windings	100



Figure 2.16: Levitation coil dimensions

Figure 2.17: A mounted levitation coil

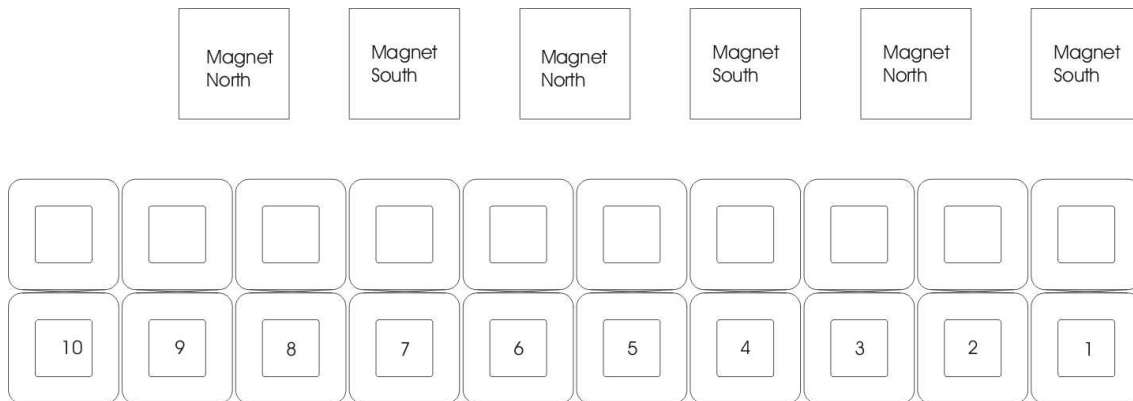

Figure 2.18: A representation of the relative positioning of the coils to the magnets

### 2.2.8 Levitation sensor board

Each one of the optical sensor boards is equipped with 8 optical sensors of which only five are used. The interaction between the sensor boards and the metal plate is based on the same principle as a caliper. Every sensor generates a signal when it is interrupted and when interruption is stopped. The metal plate on the sled has eight 'fins'. This results in  $8 \times 5 \times 2 = 80$  pulses per sensor board being passed by the sled, and with 19 sensor boards a total of 1520 pulses should be generated when the sled has reached the end of the track. The output of the sensor boards is send to its own levitation logic board. All the logic boards are linked together and form a long line over which all the sensor board signals are transmitted to an amplifier, see figure 2.20. From the amplifier the signals are send, through an opto-coupler, to the digital I/O of the DSP. The white plug in figure 2.20 with the five colored wires carries the following sensor board signals.

1. Green: Constant voltage, indication of power.



2. Yellow: Low when sled is in first sensor board.
3. Orange: At first high, goes low when front of sled interrupts light sensor four (thus sensor four goes from not interrupted to interrupted) and goes high when the end of the sled passes light sensor five (thus when sensor five goes from interrupted to not interrupted).
4. Red: Gives a pulse when a sensor goes from not interrupted to interrupted and gives a pulse when a sensor goes from interrupted to not interrupted, this is done for the first five light sensors on each of the sensor boards.
5. Brown: Ground.

The red wire carries the pulses used for the travelled distance measurement. The orange wire indicates that the sled is halfway two sensor boards.

The first two pulses generated by the sensor boards are not recognized by the DSP. Therefore a handmade sensor board is placed at the beginning of the track, see figure 2.21.

Figure 2.19: Optical sensor boards for measurement of the travelled distance

### 2.2.9 Laser

To measure the height, pitch and roll of the sled three lasers are used on the corners of the sled, see figure 2.22 and figure 2.23. Their output signals are sent to the analog input of the servo16 module 0 directly. They have a measuring range of 1.27 cm (0.5 inch) and adjustable measuring speeds. Their mounting brackets allow the user to adjust the position of the lasers. This way the lasers can be used for different tests.

### 2.2.10 Coil distribution

With 30 outputs on the DSP and 96 levitation coils on each side of the track a signal distribution is needed.

On each side the coils are grouped per five. a maximum of three groups per side can be operated simultaneously giving an area of fifteen controlled coils on each side which is always longer than the sled. Outputs 0 to 4 of the servo16 modules are used to control the coils in

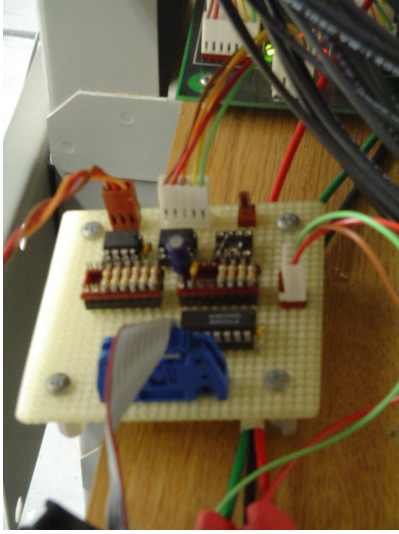

Figure 2.20: amplifier to send sensor pulses to the DSP

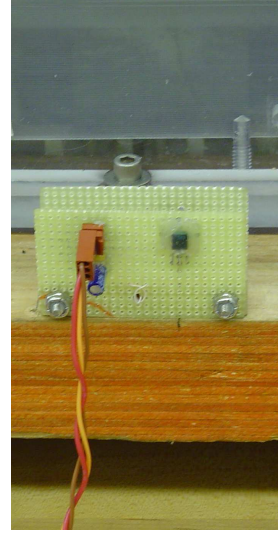

Figure 2.21: Hand made sensor to generate the first pulses

the first group, output 5 to 9 and output 10 to 14 are used for the second and the third group respectively. Due to the distribution of the signals to the levitation logic PCBs this pattern repeats itself. Thus the sixteenth coil on the left side is connected to the same DSP output as the first coil on the left side. The coils have two numbers; the actual coil, this number goes up to 96 and the number of which DSP output the coil is connected to, this number goes from 0 to 14 in the software. So to find the correct DSP output to send to the desired coil, we use the coil number -1 and then taking it modulo 15.

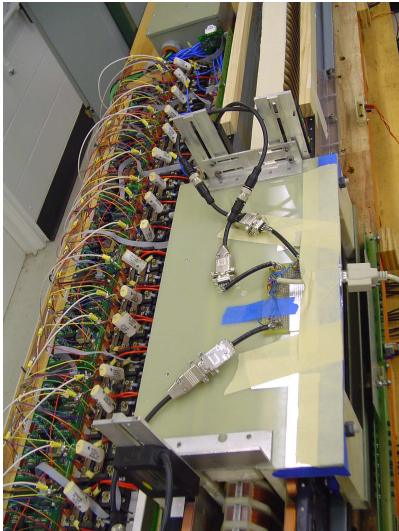

Figure 2.22: Front of the sled

Figure 2.23: Rear of the sled

## Chapter 3

# Testing the components

### 3.1 Linear motor

When the linear motor does not perform as expected there can be a problem anywhere. A problem with the sensors can be noticed by the red LEDs on the control boards. The list below can be used to find a problem with the sensors.

1. Turn off the nine power sources.
2. Move the sled all the way to the beginning of the track.
3. Check the power LEDs on the control boards, they should be on.
4. Check the sensor LEDs on the control boards, they should all be off.
5. If this is not the case check if the sensor boards are interrupted by something.
6. If this is not the case, replace the sensor board with a spare. Does this solve the problem?
7. If this is not the case, replace the control board with a spare.

The control boards make a distinct high pitch sound when they are on. This is normal. A problem with the IGBT's can be noticed by feeling the coils. If an IGBT malfunctions, most of the time the coil connected to it becomes warm. This is due to the fact that the IGBT no longer closes and continuously conducts a current through the coil. To test the IGBT, the nine power sources of the linear motor should be disconnected. An external power source, with volt and current indicators, is connected to the ground (middle connector) and plus (bottom connector) of an IGBT pair. Now, with the sensor NOT interrupted a voltage should be seen between the outputs of the two IGBT's. A voltmeter can be used to measure this. On the power source a low current can be seen. When the sensor with an uneven number is interrupted, powering the coil with a positive current, the voltage on the voltmeter should drop and the current supplied by the power source should increase. The same should happen when interrupting the even numbered sensor only now the voltage on the voltmeter should be reversed. For this test a low voltage, 5 Volt and a limited current, 5 A, suffices. When checking the IGBT's, compare the results of the different IGBT pairs. This helps identifying a malfunctioning IGBT.

### 3.2 TMS320C6701 and levitation amplifiers

One test was done to get an idea of the bandwidth of the signals that are send to the levitation coils. The tests were performed using a standard program 'wave2mod' to generate a sine wave of 1, 10, 100 and 1000 Hz at all 32 servo16 outputs simultaneously. At each frequency an amplitude of 1, 5 and 10 Volt peak-peak was used. The output of the servo16 modules was measured with the two Labview cards. The output of the amplifiers was monitored with a current probe and an oscilloscope. The graph 3.1 and graph 3.2 below show the noise on the output of the servo16 modules when their output is set to zero and the noise on the current probe when the beak is closed and empty. The other graphs show the different sine waves.

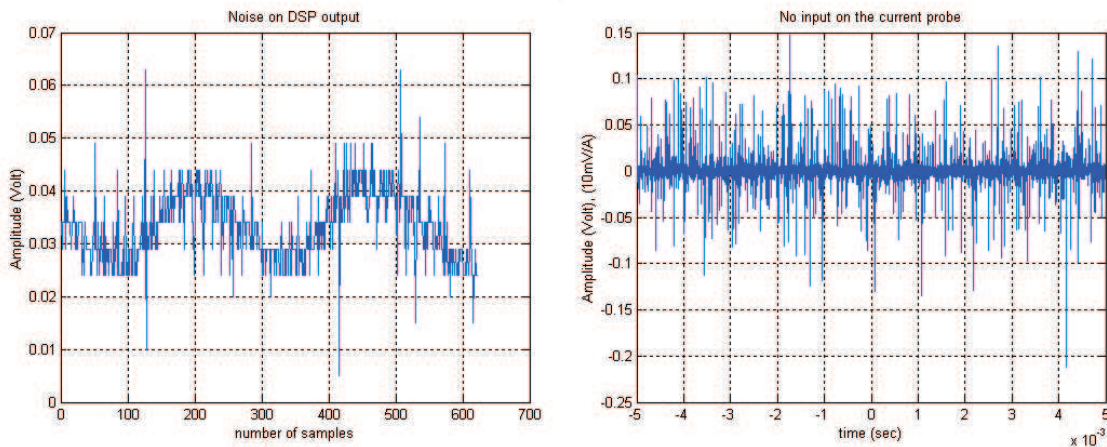

Figure 3.1: Noise levels on the DSP output      Figure 3.2: Noise levels on the current probe output

The noise levels seen on the DSP output are caused by interference from the net and the other hardware in the computer. I was not able to decrease the amount of noise. But during my activities this noise level was not jet posing a threat to the quality on the experiments. The noise on the current probe is environmental noise and is not part of the actual output signal of the amplifier. The current probe has two sensitivity levels. The sine waves with an amplitude of 10 A had to be measured at the sensitive level (10mV/A) causing the higher noise levels.

In the graphs where a sine wave of 1000 Hz is used we can see that this frequency is not reached. This is due to the software; the wave2mod program can not generate faster sine waves. In this test a maximum output frequency of 391 Hz was reached. The amplifiers follow the DSP adequately. In certain situations the desired output was not delivered to the levitation coils. For instance, a request for a current of 9 A resulted in a delivered current of 8 A. This problem might be caused by a programming error because it occurred quite random.

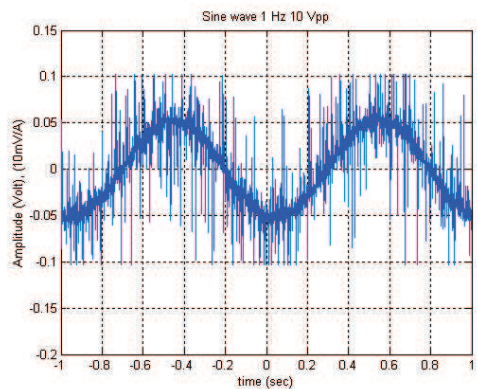
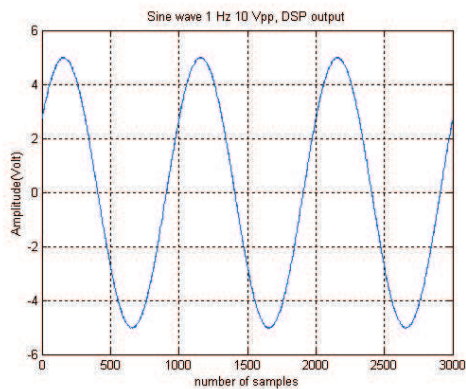
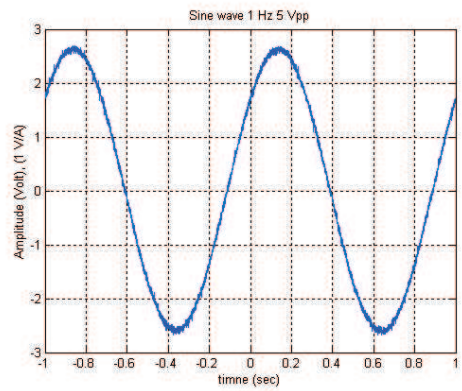
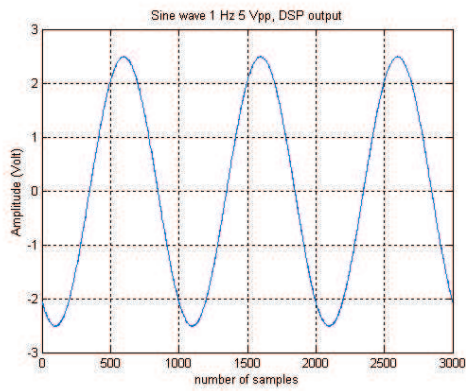
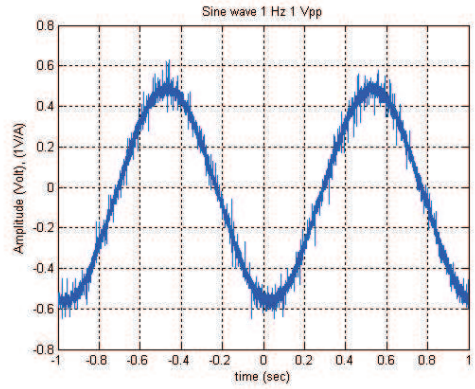
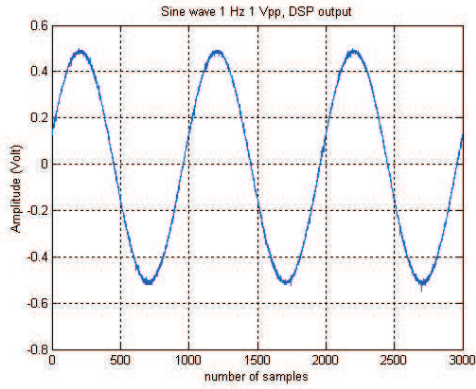

Figure 3.3: 1 Hz sine wave results

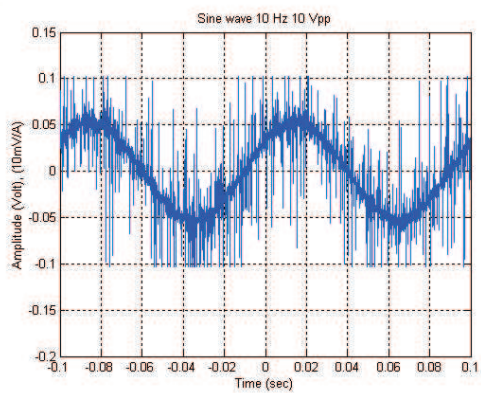
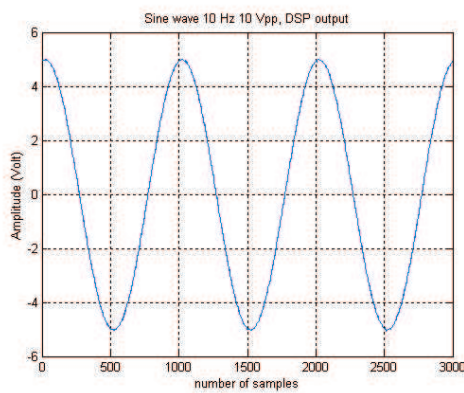
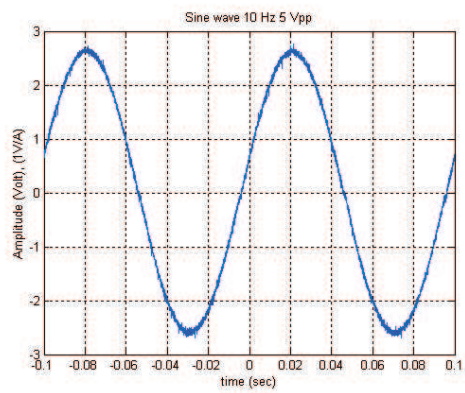
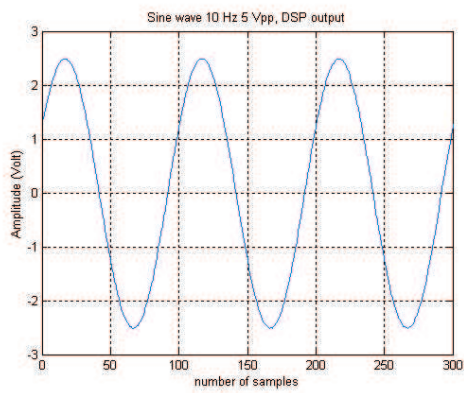
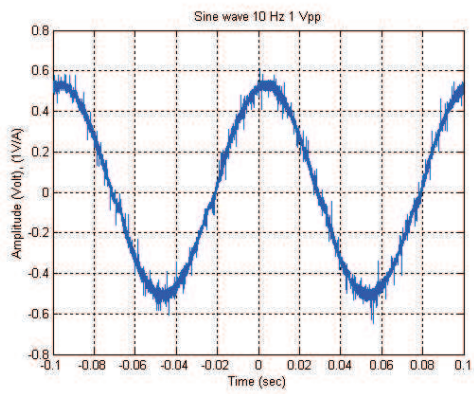
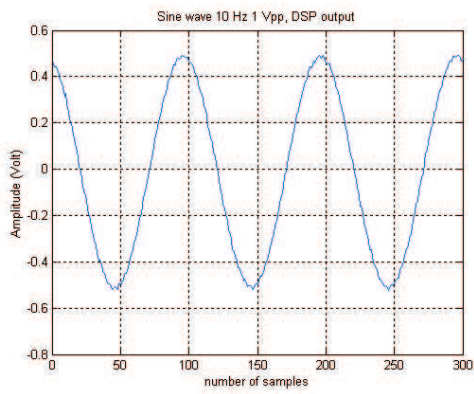

Figure 3.4: 10 Hz sine wave results

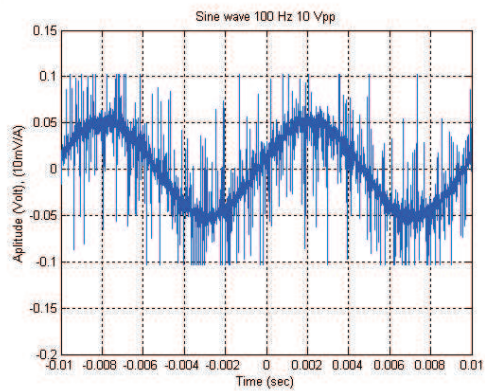
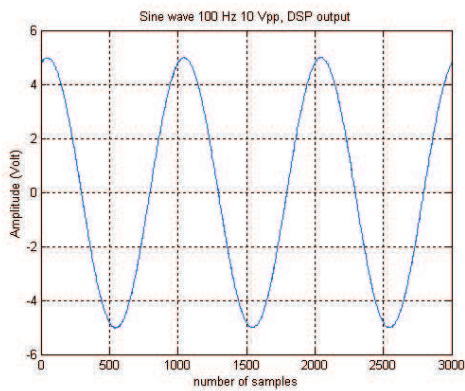
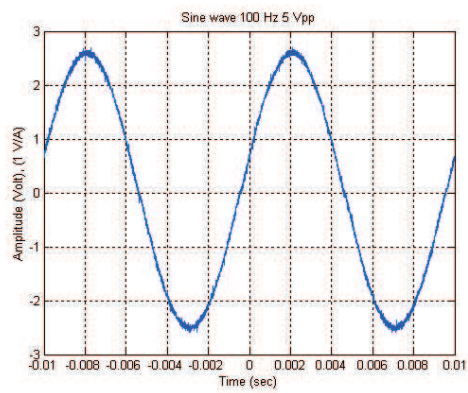
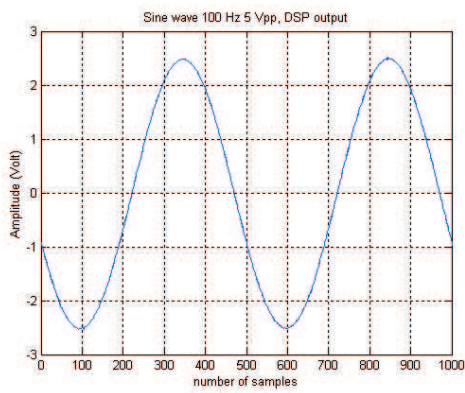
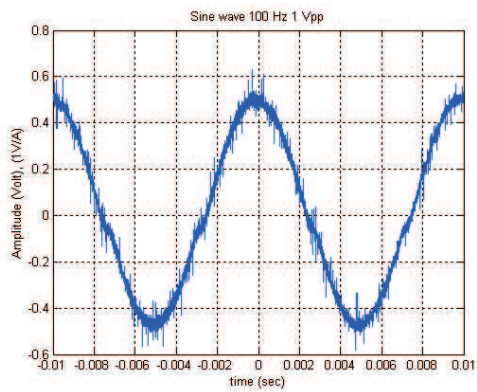
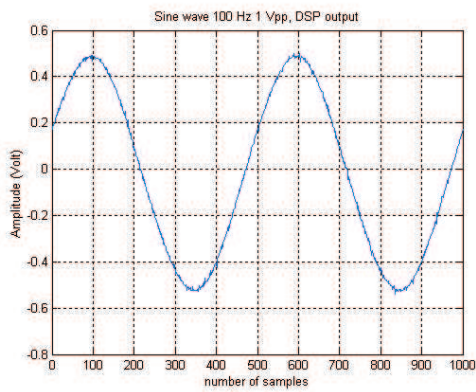

Figure 3.5: 100 Hz sine wave results



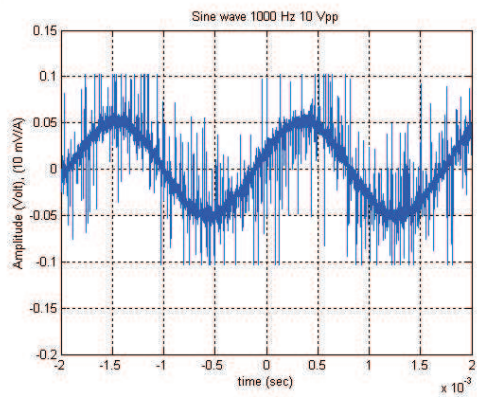
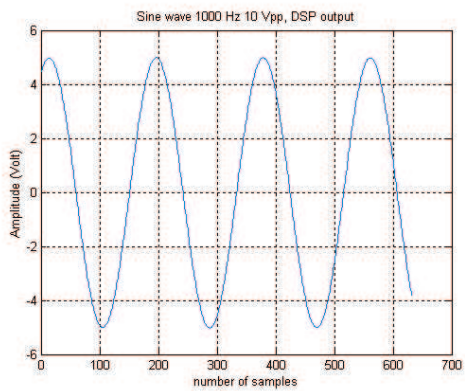
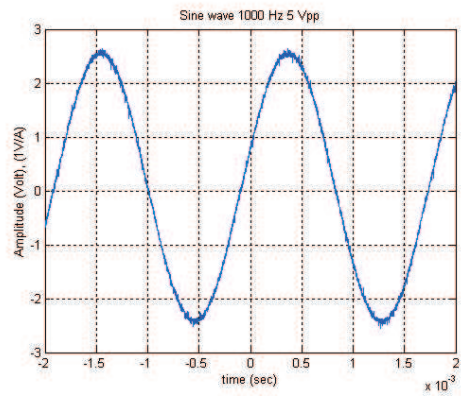
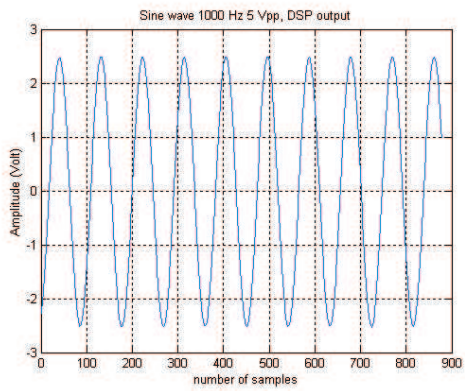
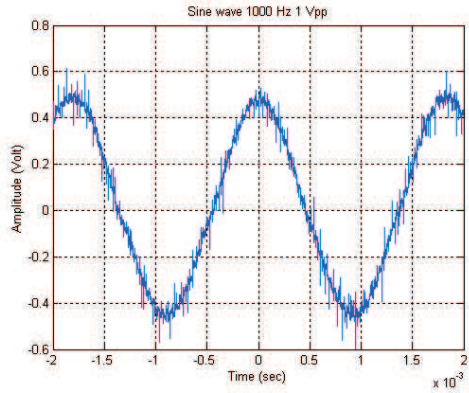
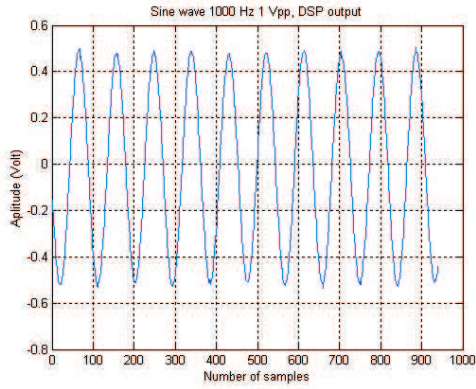

Figure 3.6: 1000 Hz sine wave results

### 3.3 Levitation sensor boards and travelled distance

When the sled travels over the entire track it should generate 1520 pulses; 19 sensor boards \* 80 pulses per board. Due to the characteristics of the interrupts of the DSP the first two pulses are not recognized resulting in a total of 1518 pulses. Now the physical distance travelled by the sled is measured using these sensors. In the software the travelled distance = received number of pulses \* 3.175 mm. Using 20 boards, which is the original number of boards, this generates 1600 pulses and thus a distance of  $1600 * 3.175 = 5.08m$ . Although this is indeed the total distance travelled by the sled, I did not trust the measurement. I have measured the physical dimensions of the sensor boards. Using these measurements and the physical dimensions of the metal plate on the left side of the sled I was able to generate table 3.1. It shows the travelled distance with each received pulse. It also shows what sensor generated the pulse. from this table we can conclude that the 3.175 mm is an estimate, the actual travelled distance per pulse varies. Though the variation in the distances between the sensors is periodic, and can thus be accounted for in the software, it makes building an accurate controller more difficult. Taking a look at the dimensions of the metal plate that passes through these sensors we can see that the eight metal 'fins' are wider than the seven 'holes'. Dave Fisher, the designer of these sensors, gave as an explanation for the difference in the distances; 'When the sled moves at full speed the sensors have to switch so fast that the difference in time needed to switch from a low to a high output and from a high to a low output becomes relevant'. So at high speeds the measurement should work optimally but at lower speeds the differences might have to be accounted for.

Pulse number 76, 79 and 80 are on the next sensor board. The sensor boards are mounted by hand and are placed approximately 1.27 cm apart. This causes a small error in the distance measurement when switching to the next board. This error might be corrected by using the sensor signal on the orange wire which tells us that the sled is halfway two sensor boards.

Table 3.1: travelled distance at each received pulse

Pulse #	Sensor #	Travelled distance (cm)	$\Delta$ distance (cm)	Pulse #	Sensor #	Travelled distance(cm)	$\Delta$ distance (cm)
1	1	0	0	41	5	14,605	0,2286
2	2	1,27	1,27	42	4	15,0114	0,4064
3	1	1,6764	0,4064	43	3	15,24	0,2286
4	3	2,54	0,8636	44	2	15,6464	0,4064
5	2	2,9464	0,4064	45	1	15,875	0,2286
6	1	3,175	0,2286	46	5	16,2814	0,4064
7	4	3,81	0,635	47	4	16,51	0,2286
8	3	4,2164	0,4064	48	3	16,9164	0,4064
9	2	4,445	0,2286	49	2	17,145	0,2286
10	1	4,8514	0,4064	50	1	17,5514	0,4064
11	5	5,08	0,2286	51	5	17,78	0,2286
12	4	5,4864	0,4064	52	4	18,1864	0,4064
13	3	5,715	0,2286	53	3	18,415	0,2286
14	2	6,1214	0,4064	54	2	18,8214	0,4064
15	1	6,35	0,2286	55	1	19,05	0,2286
16	5	6,7564	0,4064	56	5	19,4564	0,4064
17	4	6,985	0,2286	57	4	19,685	0,2286
18	3	7,3914	0,4064	58	3	20,0914	0,4064
19	2	7,62	0,2286	59	2	20,32	0,2286
20	1	8,0264	0,4064	60	1	20,7264	0,4064
21	5	8,255	0,2286	61	5	20,955	0,2286
22	4	8,6614	0,4064	62	4	21,3614	0,4064
23	3	8,89	0,2286	63	3	21,59	0,2286
24	2	9,2964	0,4064	64	2	21,9964	0,4064
25	1	9,525	0,2286	65	1	22,225	0,2286
26	5	9,9314	0,4064	66	5	22,6314	0,4064
27	4	10,16	0,2286	67	4	22,86	0,2286
28	3	10,5664	0,4064	68	3	23,2664	0,4064
29	2	10,795	0,2286	69	2	23,495	0,2286
30	1	11,2014	0,4064	70	1	23,9014	0,4064
31	5	11,43	0,2286	71	5	24,13	0,2286
32	4	11,8364	0,4064	72	4	24,5364	0,4064
33	3	12,065	0,2286	73	3	24,765	0,2286
34	2	12,4714	0,4064	74	2	25,1714	0,4064
35	1	12,7	0,2286	75	6	25,41778	0,24638
36	5	13,1064	0,4064	76	5	25,8064	0,38862
37	4	13,335	0,2286	77	4	26,035	0,2286
38	3	13,7414	0,4064	78	3	26,4414	0,4064
39	2	13,97	0,2286	79	7	26,68778	0,24638
40	1	14,3764	0,4064	80	6	27,09418	0,4064

### 3.4 Levitation coil

When we started with the MAGLEV track it was uncertain whether all the coils were functioning and connected correctly. A program, stefan14.c, was written to test this. The user can specify the frequency and amplitude of the sine wave and the time it should be applied to each coil. After a delay of 5 seconds, which gives the user time to start the Labview computer and to go to the coils with the compass, the DSP sends this signal to the coils. Figure 3.7 and figure 3.8 show the output of the two servo16 modules. First the first coil on the right side is driven then the first coil on the left side and so on. We also see that while the program is running the outputs of the unused channels are pulled to zero. As soon as the DSP is reset all the outputs are released and the noise level increase, as visible in these graphs. These graphs were generated with Labview while the PWM boards were turned of because the PWM boards induce noise. The user can turn the PWM boards on and use the compass to see whether the coils are connected correctly and whether the levitation amplifiers are working. If more detailed data is needed the compass can be replaced by the current probe and an oscilloscope. The tests showed that the coils were connected correctly.

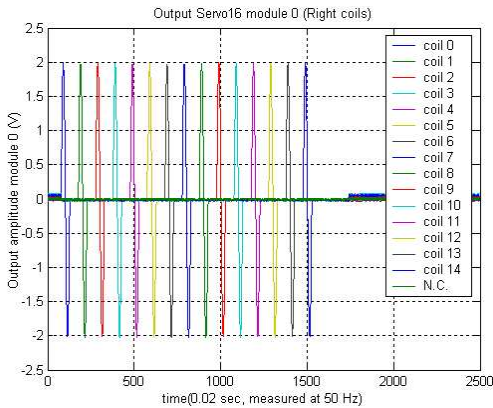

Figure 3.7: Output of servo16 modules to test the right coils

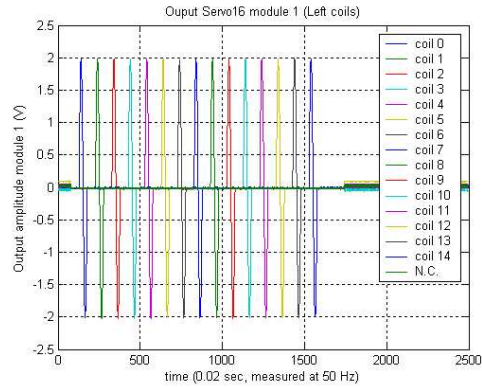

Figure 3.8: Output of servo16 modules to test the left coils

Because the track was not build to specifications the positions of the coils are not exactly known. An average of 16 sensor pulses per coil is used as rule of thumb. To determine the exact location of the coils the two lasers at the rear of the sled were pointed at the top of the levitation coils. the sled was moved forward by hand, the sensor pulses are registered as is the coil surface as seen by the lasers. After a correction, needed for the different measurement places of pulses and lasers, the pulses and laser output were plotted together, see figure 3.9. Every time the lasers are reading the 'top' of a coil the 'coil present' indication in the plot goes high. As we can see in the plot the sides of the coils, indicating the start and finish of a coil, cause a very steep in(de-)crease in the output voltage of the lasers. We can see in the plot that the 16 pulses per coil is a good average but is not exact. there is a variation of +/-1 pulse. And each pulse indicates an average of 3.175 mm. This makes the determination of where the coils are underneath the sled inaccurate. But using the data generated with this measurement the variation of the coil positions can be accounted for in the software.

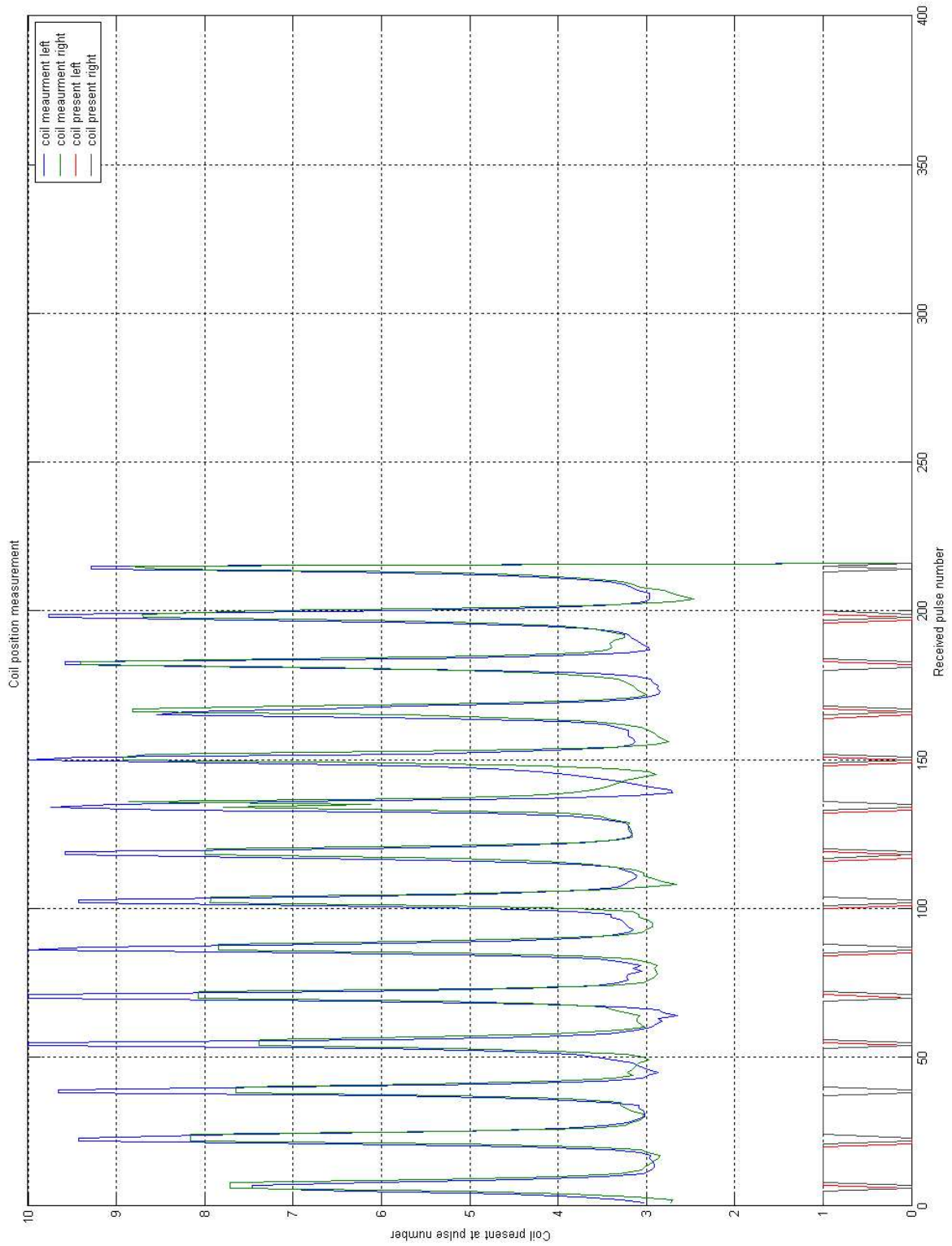

Figure 3.9: Measurement of the coil position

### 3.5 Laser

During the internship the components of the MAGLEV track were already defined. Also the lasers used for the height, pitch and roll measurements of the sled. Because the documentation was vague about the accuracy and settings of the lasers I made a test setup to test the lasers which is shown in figure 3.10. Table 3.2 and figure 3.11 show the results. The laser has a measurement range of 12.7 mm (0.5 inch). The shortest distance it was set to measure is 45 mm (1.77 inch). Thus the 0 mm level in the table is 45 mm below the casing of the laser. We can see that the output of the laser is linear with the distance. This results in the following relation between measured height in mm and output voltage;

$$Height = 45 + (voltage - 2) * 1.5875 \tag{3.1}$$

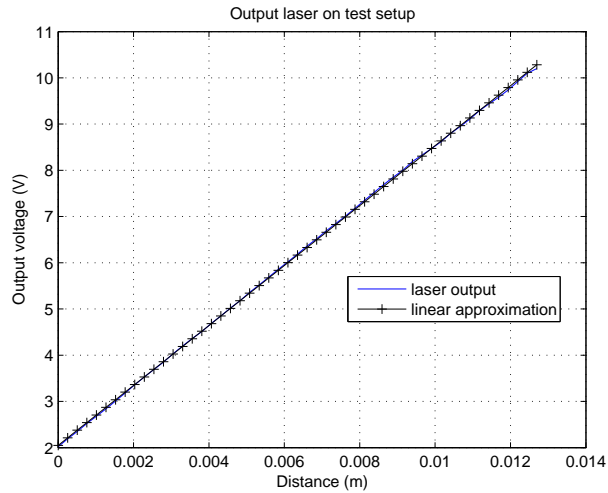

Figure 3.10: setup made to test the laser output

Figure 3.11: Output characteristics of the laser

Testing the output of the lasers it was seen that noise levels were influenced by two factors:

1. The surface which reflected the laser beam
2. The speed with which the measurement was done.

Table 3.3 shows the average noise levels as a result of using different surfaces. The telemetric survey tape has two values; 265 mV on the black parts of the tape and 55 mV on the reflective parts of the tape, see figure 3.13. Table 3.3 shows us that it is advisable to apply reflective tape on the surfaces used by the lasers for the distance measurement.

The speed with which the lasers can measure can be varied from 4.5 Hz to 45 Hz to 450 Hz according to the documentation. But the highest measurement speed resulted in a signal update every ms. Due to the speed of the sled on the track only the highest measurement

Table 3.2: measurement data from laser test

Height (inch)	Output (V)	Height (inch)	Output (V)
0.000	2.02	0.250	6.19
0.010	2.19	0.260	6.36
0.020	2.35	0.270	6.52
0.030	2.52	0.280	6.69
0.040	2.68	0.290	6.85
0.050	2.84	0.300	7.01
0.060	3.01	0.310	7.18
0.070	3.18	0.320	7.35
0.080	3.36	0.330	7.52
0.090	3.53	0.340	7.69
0.100	3.69	0.350	7.85
0.110	3.85	0.360	8.00
0.120	4.03	0.370	8.19
0.130	4.20	0.380	8.33
0.140	4.36	0.390	8.47
0.150	4.51	0.400	8.62
0.160	4.69	0.410	8.80
0.170	4.85	0.420	8.95
0.180	5.02	0.430	9.11
0.190	5.18	0.440	9.29
0.200	5.36	0.450	9.44
0.210	5.52	0.460	9.58
0.220	5.69	0.470	9.74
0.230	5.86	0.480	9.92
0.240	6.02	0.490	10.1
		0.500	10.2

Table 3.3: noise levels due to reflection surface

Material	Brand	average noise level (mV peak - peak)
massive aluminum		15
Reflective tape	(Avery)	30
Reflective tape	(NATIONAL)	30
Dark brown tape	(3M)	30
Light brown tape	(3M)	30
black electrical tape		285
telemetric survey tape		265 and 55

speed can be used. During the testing of the different surfaces the measurement speed of the laser was set to its maximum. In figure 3.14 we can see that, when using a good reflecting surface, the difference in the noise levels is minimal due to different measurement speeds.

Because the range of the lasers (0.5 inch or 1.27 cm) is slightly smaller than the freedom of movement of the sled in upward direction much attention must be paid to the mounting of the lasers on the sled and to the position of the lower support rail. See figure 3.12. This because of two facts:

1. With the support rail the position of the magnets with respect to the coils is determined and thereby the efficiency of their interaction.
2. The support rail determines the initial height of the sled on the track and can thus cause the lasers to be out of range.

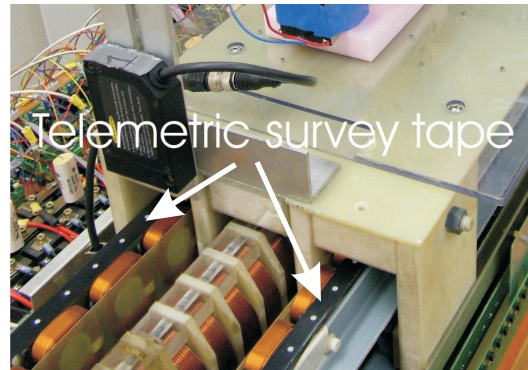

Figure 3.12: laser mounting brackets and lower support rail

Figure 3.13: telemetric survey tape

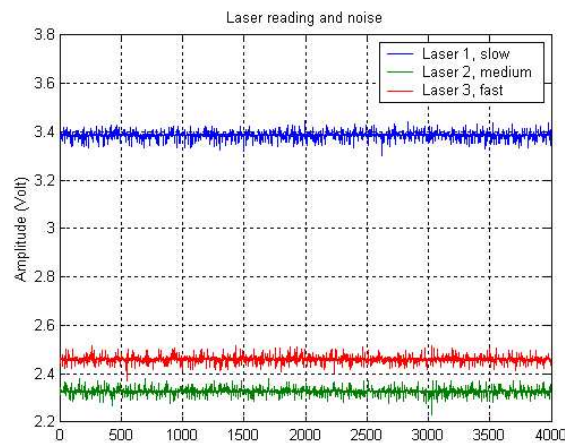

Figure 3.14: Different measuring speeds with good reflective surface

The laser test setup was also used to calibrate the lasers to the same input and output range.



### 3.6 Testing the control loop

After all the subsystems are tested a simple program is written to test their combined functionality. The sled is moved forward by hand causing the output of the lasers to vary. This variation, from laser 2, is used to adjust the amplitude of the outputs of the servo16 modules. The measurement of the travelled distance is used to enable the next coil when the sled moves forward. During the test two coils are powered at the same time and every eight pulses one of them is turned off and a new one is turned on. The output of the laser and the reaction of the DSP to the laser can be seen in figure 3.6. In the third graph an enlarged part of the second graph is visible, here we see that the coils switch as desired. Every eight pulses a new coil is enabled. At any time two coils are enabled, this leads to the half overlap of the DSP signals.

Significant noise levels can be observed on the laser output. As mentioned before, this is caused by the bad reflective property of the black parts of the telemetric tape.

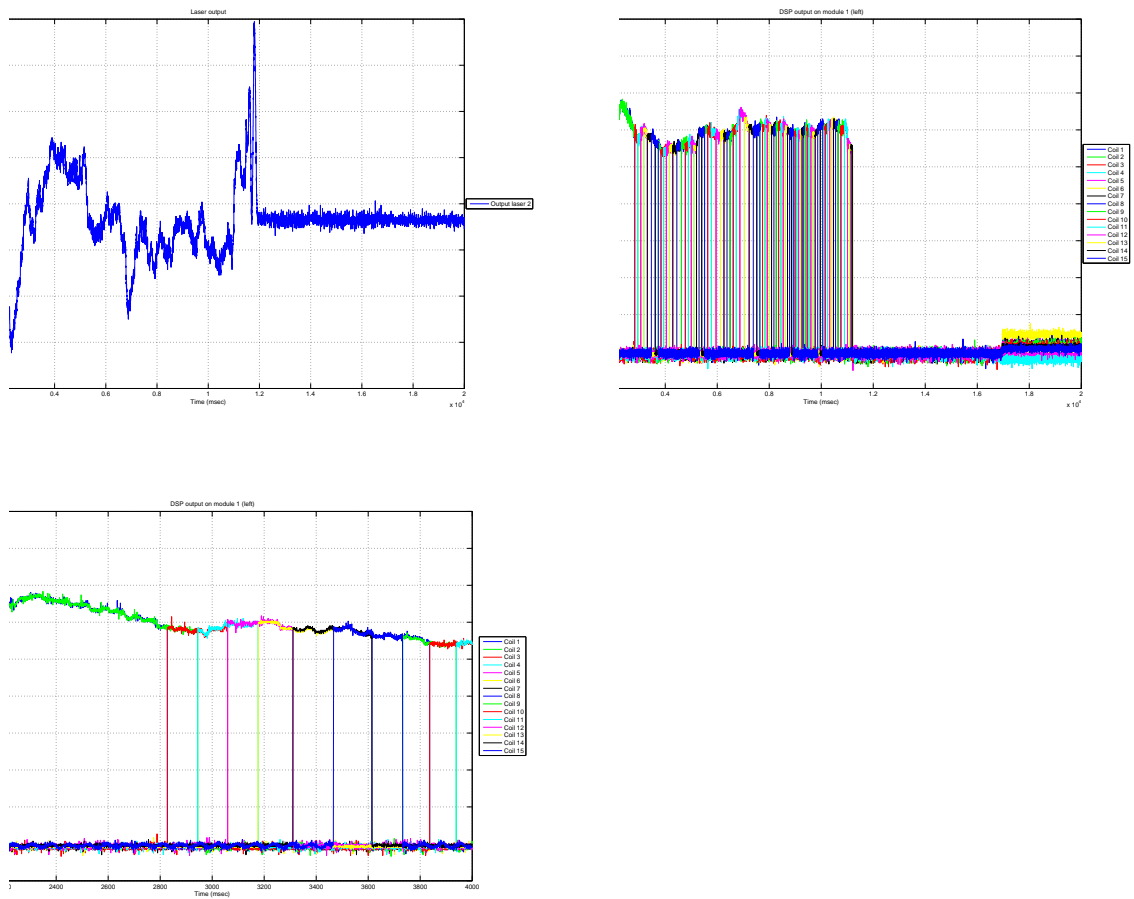

Figure 3.15: Results of the control loop test

### 3.7 Testing levitation

See figure 3.16. Magnet 1 indicates the front of the sled. Coil 1 indicates the beginning of the track.

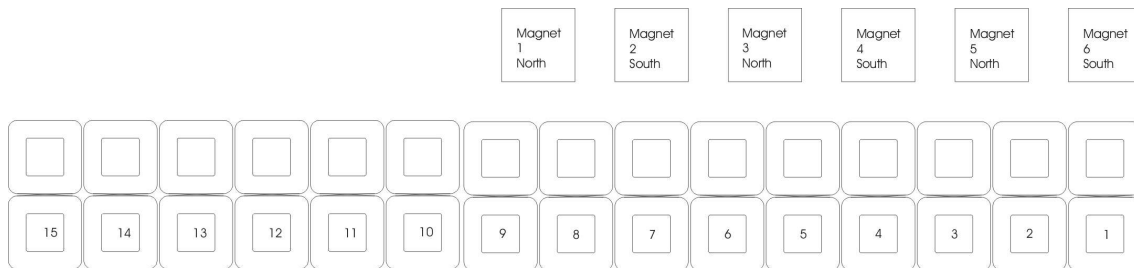

Figure 3.16: numbering of the coils and magnets

With the first experiment only coils 1, 4 and 7 on each side are used. The current through the levitation amplifiers is set to 10 A. This does not levitate the sled. With a second experiment constant currents of -10 A and +5 A are applied to coils 1, 4 and 7 and to coils 2, 3, 5, 6, 8 and 9 respectively. The sled is levitated though with a lot of vibration. What is found out very quickly is that when the magnets are not positioned symmetrically above the coils, they generate relatively large forces in forward and or backward direction. This causes the sled to 'stick' to the track; the magnets will move towards an adjacent coil (which had an attracting magnetic field) and then will be pulled towards it. To avoid this problem the sled is fixated at the beginning of the track with a long piece of tape, See figure 3.17.

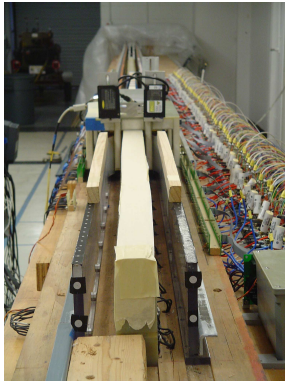
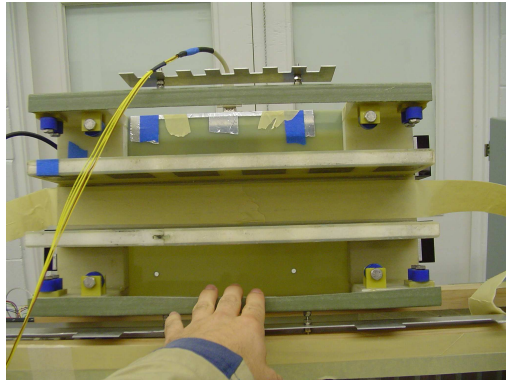
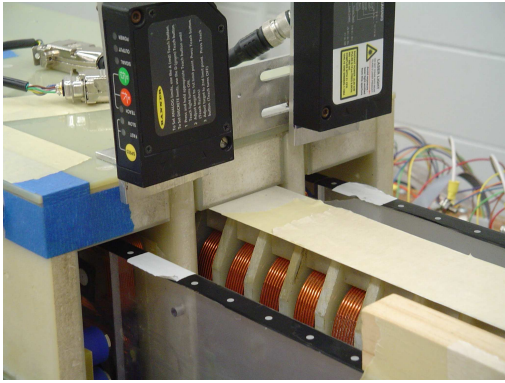

Figure 3.17: Tape used to keep the sled in place

When using all the coils the sled is lifted easily. The next experiment roughly shows the point where the sled starts to levitate. All nine coils underneath the sled are used. The current through coils 2, 3, 5, 6, 8 and 9 is increased from 0 to 10 A and the current through coils 1, 4 and 7 is increased from 0 to -10 A. The current is increased with steps of 1 A per 2 seconds, see figure 3.18. With a current of 1 through 5 A very small increments in height are visible at the output of the lasers. At 6 A the sled is levitated but very unstable. The wheels of the sled touch the upper support rail and this influences the response of the sled to the coils. Therefore the upper rail is removed which results in figure 3.19. Here we see that, again, at 6 A the sled is levitated only now the height of the sled is quite stable.

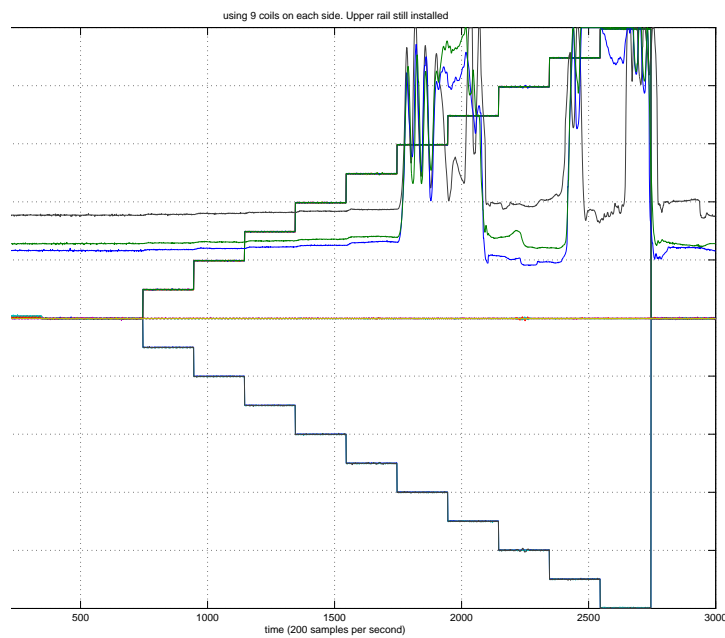

Figure 3.18: incrementing the current from 0 to 10 A with the upper support rail

Incrementing the current through the coils from 5 to 6 A with steps of 0.1 A gives the results as can be seen in figure 3.20. This shows that a lower current should be able to levitate the sled as well. Figure 3.21 shows that the sled starts to levitate at 5 A.

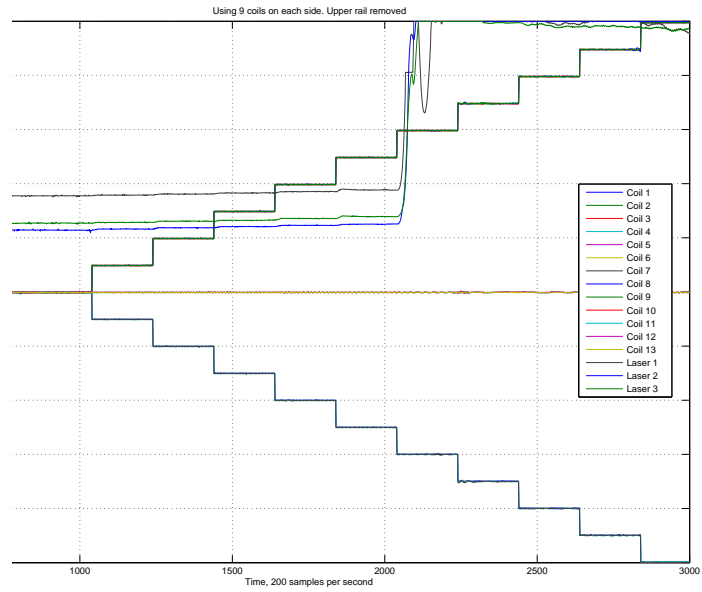

Figure 3.19: incrementing the current from 0 to 10 A without the upper support rail

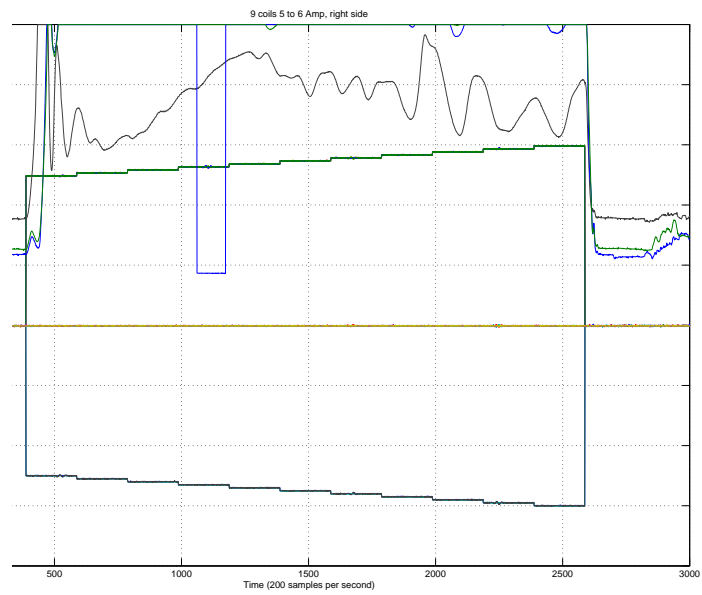

Figure 3.20: determining point of levitation

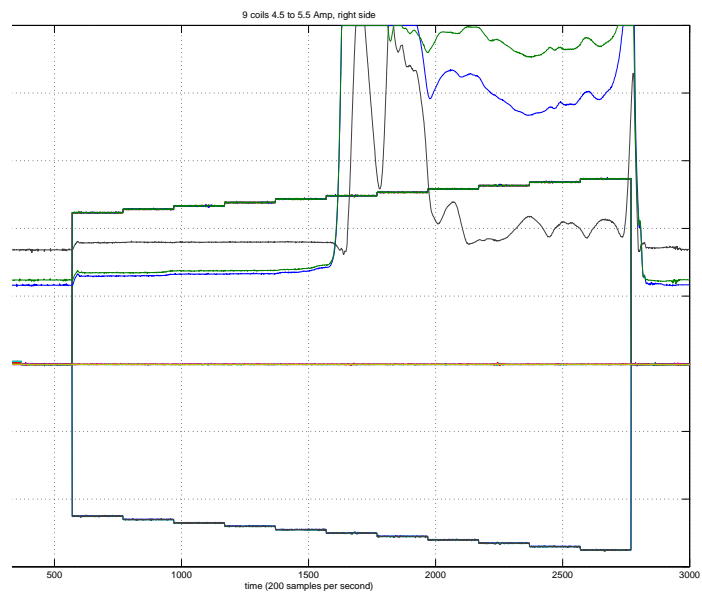

Figure 3.21: determining point of levitation

The lower support rail determines the starting height of the sled and therefore has influence on the performance. Normally the lower support rail is at its lowest position possible, placing the magnets centers at the same height of the coil centers. figure 3.22 shows the reaction of the sled when the lower support rail is moved up as high as possible. This starting position causes a high frequent vibration and is not successful.

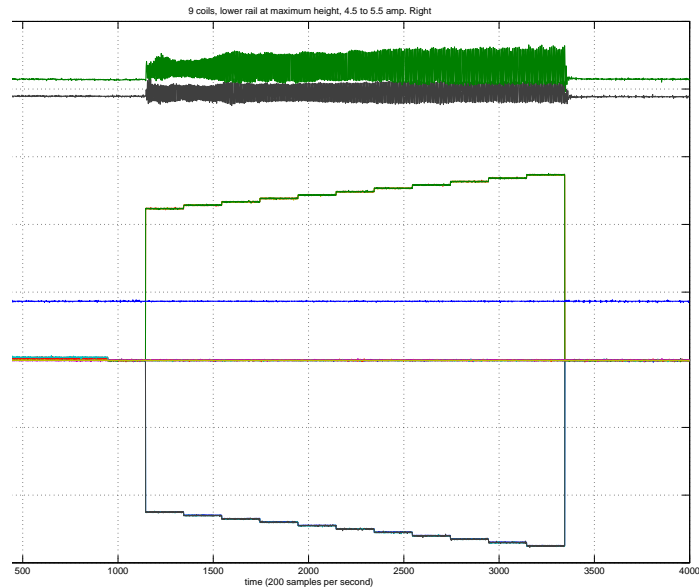

Figure 3.22: Lower support rail at maximum height

During these tests a problem was encountered with the mounting of the levitation coils. The levitation coils are slid over two short plastic sticks. During the tests the coils themselves vibrate as well. This causes unmodelled dynamics and with this range of freedom the coils can touch the side of the sled and thereby generate friction that prevents the sled to move.

The last test that is done is to prove that the signals from the DSP are send to the correct coil. See figure 3.23. This graph combines the measurement of the coil positions with the output of the DSP to one single coil. See figure 3.16. When the sled moves forward the magnets pass the different coils. For example, when magnet 2 is above coil 7, a positive current is needed to push magnet 2 up. Now if the sled moves further, with the distance of one and a half coil, magnet 3 is above coil 7. Because of the opposite magnetic field of magnet 3 the current through coil 7 needs to be inverted. Now with 6 magnets this means that the signal send to one coil needs to switch sign 6 times. And when the next group of fifteen coils is reached this happens again. In the graph the first square wave of each sequence of six overlaps a 'coil arc' indicating that that sequence of six square waves (currents) is send to that coil. The first square wave indicates that the front of the first magnet is just over that coil resulting in a positive current through that coil. Now this current is send until the entire magnet is over that coil. If the sled moves further, the current is set to zero. This to prevent unwanted interaction with the next magnet. If the sled moves forward 'half a magnet' the front of the

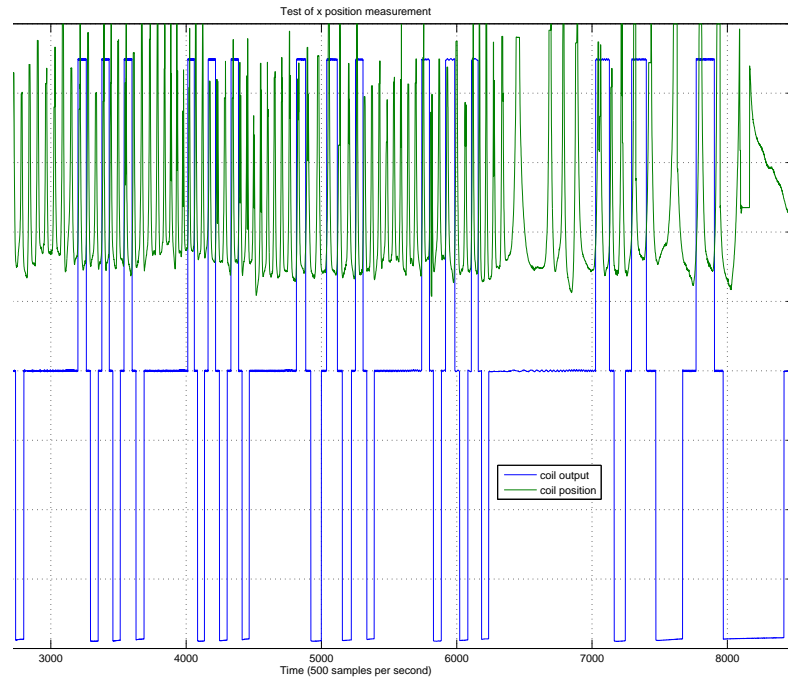

Figure 3.23: Verification of signal distribution

second magnet is just over the coil resulting in a negative current through the coil. This current is send until the second magnet is completely over the coil. When it moves further the current is set to zero again to prevent unwanted interaction with this coil and the third magnet. This continues until the six magnets all passed this one coil. When the sled has passed fifteen coils everything happens again because of the coil distribution.

### 3.8 Quick startup test and check lists

The following checklists help performing a quick check to see if nothing is forgotten when working with the track and if everything works. Most errors are found this way, if the track acts in an unexpected way then the more thorough tests described in the previous sections can be performed.

#### Checklist for turning the track on

1. Move the sled all the way to the beginning of the track, make sure it does not interrupt any of the sensors.
2. Turn on master power switch.
3. Turn on red power switch on the grey cabinet next to the desk.
4. Turn on levitation logic boards on the grey cabinet with the linear motor amplifiers.



5. Check LEDs on the levitation logic boards, each board should have two green LEDs on (power) and two red LEDs off (sensor is interrupted).
6. Make sure nothing is interrupting the sensors.
7. Check the levitation sensor boards. Move the sled, by hand, forward starting at the beginning of the track. Interrupting sensors board  $n$  should cause both red led's on boards  $n-1$  ,  $n$  and  $n + 1$  to light up. At all time at least two logic boards will have both red LEDs on during this test (when the sled is exactly halfway two sensor boards or at the beginning or end of the track), or three logic boards (in all other cases).
8. Turn on the levitation power sources, put them on 'stand by', figure 3.24.
9. Check that both the levitation power sources are set to 20 Volt and 70 Ampere.
10. Turn on the control logic of the linear motor on the grey cabinet with the linear motor amplifiers.
11. Check the linear motor logic boards, all six led's on each boards should be off.
12. Test the function of the sensors of the linear motor by interrupting one sensor at a time. The led's should light up in a distinct order (1, 3, 5, 2, 4, 6).
13. Turn on the computers.
14. Turn on the power source for the PWM boards on the desk.
15. Turn on the power source for the lasers, this one is also on the desk

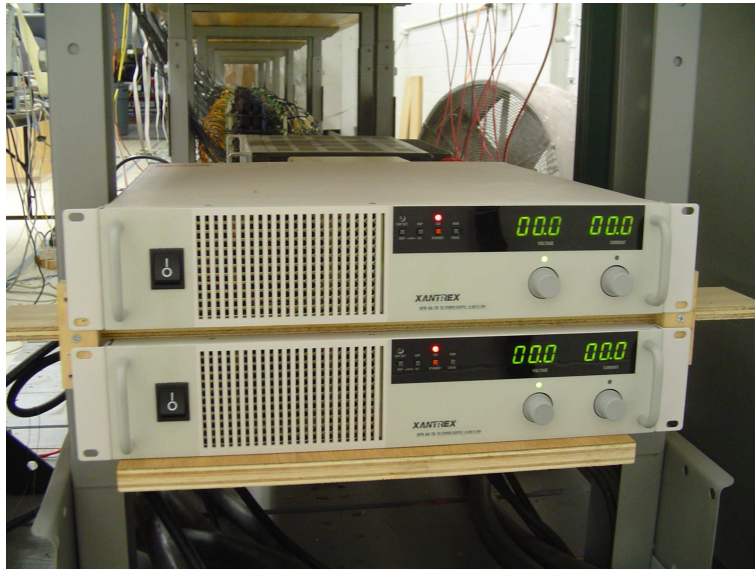

Figure 3.24: Power sources for the levitation amplifiers

**Checklist for turning the track off;**

1. Turn the nine power supplies of the linear motor off.
2. Turn off power for linear motor logic.
3. Set levitation power supplies to 'stand by'.
4. Turn off levitation power sources.
5. Turn off levitation logic power.
6. Turn off laser power.
7. Turn off PWM board power.
8. Turn off computers.
9. Turn off red power switch.
10. Turn off main power switch and lock it.

**Checklist for starting a test on the track**

1. Is the track clear and clean?
2. If needed, are the nine power supplies of the linear motor turned on?
3. Are the levitation power supplies 'active' in stead of 'stand by'?
4. Laser power supply turned on?
5. PWM board power supply turned on?
6. Sled on the correct position?
7. Is the cable connected to the sled?
8. Compass, current probe and or other tools ready?
9. Labview computer ready to measure?
10. DSP software ready to run?

**Checklist for ending a test on the track**

1. Set the levitation power supplies to 'stand by'.
2. Turn off linear motor power supplies.
3. Move sled to beginning of the track, it is no longer in any of the sensor boards.
4. Save Labview data and or oscilloscope data if needed.
5. Check sensor boards for damage, can be done by checking the led's on both control PCB's.

## Chapter 4

# Applying control

Due to the limited time left only a few very simple control algorithms could be applied to the MAGLEV track. Only levitation control tests without forward movement are done. I have not been able to levitate the sled while moving it forward.

The sled, and the coils underneath are divided in four quadrants; front right, rear right, rear left and front left, see figure 4.1. Only the coils and magnets are drawn. Quadrant 1 through 3 all have a laser to determine the height  $H_1$  to  $H_3$  of their outer corners using (3.1). The height of the fourth quadrant is calculated using the height of the other quadrants. First the height of the center of the sled,  $H_c$  is calculated using  $H_1$  and  $H_3$ ;

$$H_c = \frac{H_1 + H_3}{2} \quad (4.1)$$

Now the height of the outer corner of the fourth quadrant equals  $H_c$  plus the height difference between  $H_c$  and  $H_2$ . After simplification this gives;

$$H_4 = (H_c - H_2) + H_2 \quad (4.2)$$

$$H_4 = \frac{H_1 + H_3}{2} - H_2 + \frac{H_1 + H_3}{2} \quad (4.3)$$

$$H_4 = H_1 + H_3 - H_2 \quad (4.4)$$

We only apply P, PI and PID controllers. The advantage of these controllers is that they can be tuned with little prior knowledge of the system or models. Because we do not expect the controllers to perform very well we want them to be as fast as possible to still obtain a reasonable result. Therefore we make the following simplifications;

- 1 The coils in each quadrant will be grouped. Coil 5, 6, 7, 8 and 9 in quadrant 1 and 4 and coil 1, 2, 3 and 4 in quadrants 2 and 3. Coils 1, 4 and 7 will receive signals with an opposite sign because they interact with the opposite magnetic pole.
- 3 We will only look at the forces in z direction. The forces in x and y direction are omitted.
- 4 The magnets do not move in x or y direction.
- 5 The magnets magnetic field strength in y direction is constant and the magnetic field strength in x and z direction is zero.

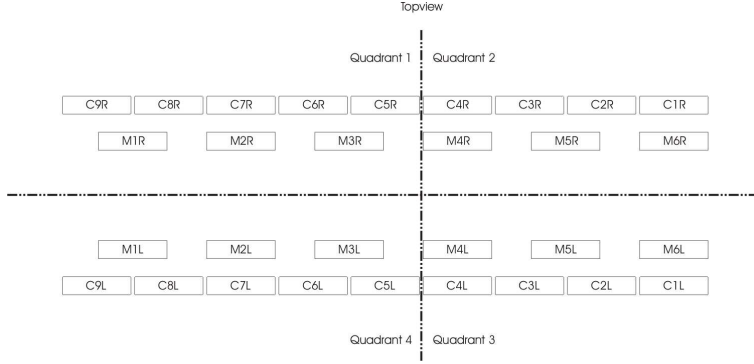

Figure 4.1: Division into four quadrants, top view

These are very rough simplifications and will, as we will see later, reduce the relation between coil current and sled movement to a simple multiplication with a constant. These simplifications might not be justifiable but due to the lack of time this is my only option. The force in z direction between a magnet and one coil equals;

$$F_z = i_a 2NB_y b \quad (4.5)$$

The force in z direction between a magnet and two coils equals;

$$F_z = i_a 2NB_y 1/2b + i_b 2NB_y 1/2b \quad (4.6)$$

With:

- $i_a$  is the current through the coil
- $i_b$  is the current through the coil
- $N$  the number of windings per coil
- $B_y$  the magnetic field in y direction
- $b$  the width of the coil

The number of windings is 100, the width of the coil is  $50.8 \cdot 10^{-3}$  m and  $B_y$  is estimated to be 0.17 T ( $B_y$  was actually measured and 0.17 was taken as an average). When we fill in these numbers and with  $i_a = i_b$  we get for the force in z direction in both cases;

$$F_z = i * 1.7272 \quad (4.7)$$

We will treat both situations as if they are the same. Quadrants 1 and 4 both have five coils. Quadrants 2 and 3 only have four. Due to the simplifications used above this makes no difference anymore for the controller. With the sled's weight estimated at 8 Kg we would need a total  $F_z$  of  $8 * 9.81 = 78.48N$ . This is 19.62 N per quadrant. Per quadrant we have three magnets and the  $F_z$  per quadrant equals;

$$F_z = i * 3 * 1.7272 \quad (4.8)$$

$$F_z = i * 5.1816 \quad (4.9)$$

Thus to cancel the gravitation force we would need a current with an absolute value of approximately 3.79 A per coil. Comparing this with the results from chapter 5 we can see that this value is indeed correct. With the coils at 2 A and at 4 A we can see small increments in the output of the lasers. The sled is indeed lifted with a current of around 3 A. To really levitate the sled, and thus produce a force larger than the gravity acting on the sled a current of approximately 5 A is needed.

## 4.1 experiments

Numerous experiments were done to obtain an insight in the dynamical behavior of the MAGLEV track. They will not be treated here. The results and a short description of these experiments can be found in appendix 4. From these experiments the following conclusions were drawn;

1. The system performs best when using a reference height of 4 mm. This should result in a voltage increase of  $4 \cdot 0.63 = 2.52V$  at the output of the lasers.
2. Due to the hardware only short experiments, up to 10 seconds, could be performed. This made it impossible to use very little values for an integral action of the PI and PID controller. Very large values for the proportional, integral or differential action resulted in actuator saturation and an unstable system. This limited the choice of these variables.
3. When high frequent currents, with maximum amplitude, are followed by very steady laser outputs two things might have happend;
  - Miraculously the system has recovered from instability and the sled is at the desired height. This is very optimistic.
  - The setup does not work, The coils have been vibrating and now clamp onto the sled in such a way that it can not move anymore. Causing the laser output, and thus the current through the coils, to be stable. If the controller has an integral action we will see the current through the coils change.

For these experiments I have implemented a separate controller for each corner of the sled. This is not optimal because the control actions of one controller influences the other controllers but, it might still give an impression of the capabilities of the MAGLEV track. Three types of controllers were applied; P, PI and PID. The general structure used with these controllers is as follows;

1. With the sled in rest, determine the height of each corner of the sled.
2. Add to these values the user defined offset (In these experiments this was set to 4 mm).
3. Use these values as reference values for the controllers

#### 4. Start the controller

Each controller has its own reference value. This way, theoretically, the sled is only moved in upward direction. The roll and pitch of the sled should not change. When an experiment starts the output of the lasers differ. This can be used to quickly notice, from a graph, if the sled pitched or rolled during an experiment; if the sled rolls, the difference between the output of laser 2 and 3 changes. If the sled pitches, the difference between the output of laser 1 and 2 (or 3) changes.

## 4.2 Proportional control

Controlling with only a proportional action is not very successful. A controller with only a proportional action performs poorly, see figure 4.2 and figure 4.3. Here a  $K_p$  of 1 is used. The system is stable but does not achieve the desired goals; the sled is levitated without vibration but not at the desired height. Using a  $K_p$  of 3 resulted in a second of high frequent vibrations (instability) followed by very constant laser outputs, see figure 4.4 and figure 4.5. I am quite sure that the coils clamped onto the sled. Figure 4.5 and figure 4.3 show that the controller does not always function as wanted; one coil signal is 1 A during almost the entire experiment.

The speed of this controller was determined by switching an unused output on module 1 of the DSP every time the control loop was used, see figure 4.6. It is a rough measurement but taking the average of the pulse lengths leads to a frequency of approximately 6.250 KHz.

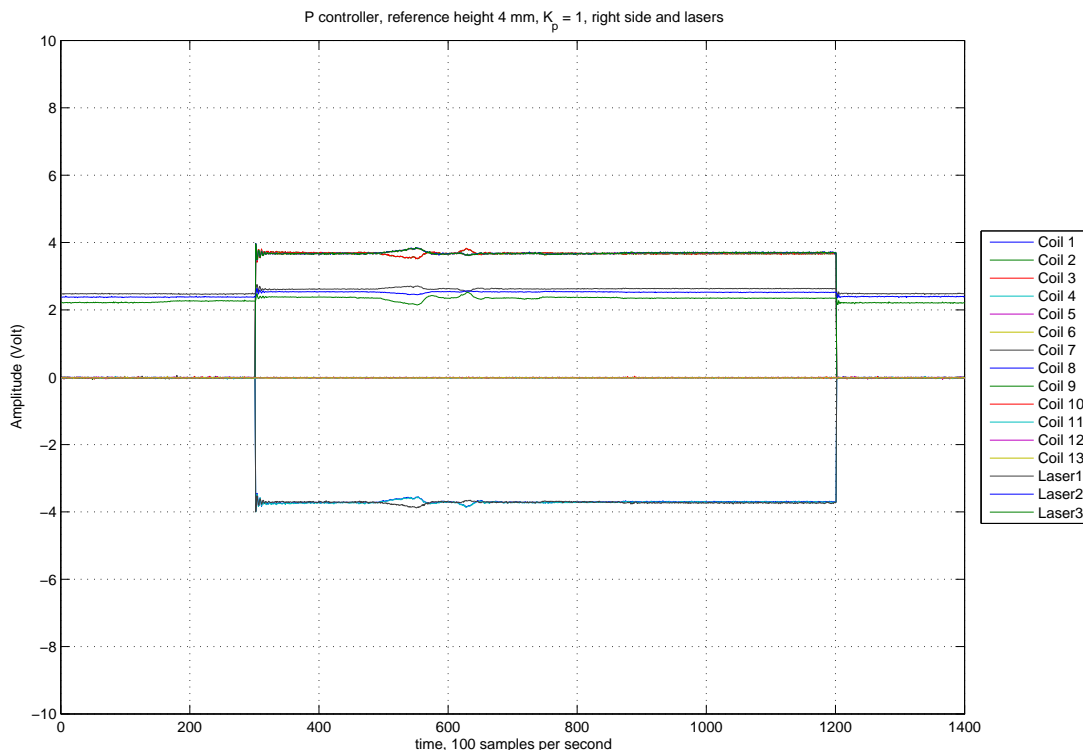

Figure 4.2: P control,  $K_p = 1$

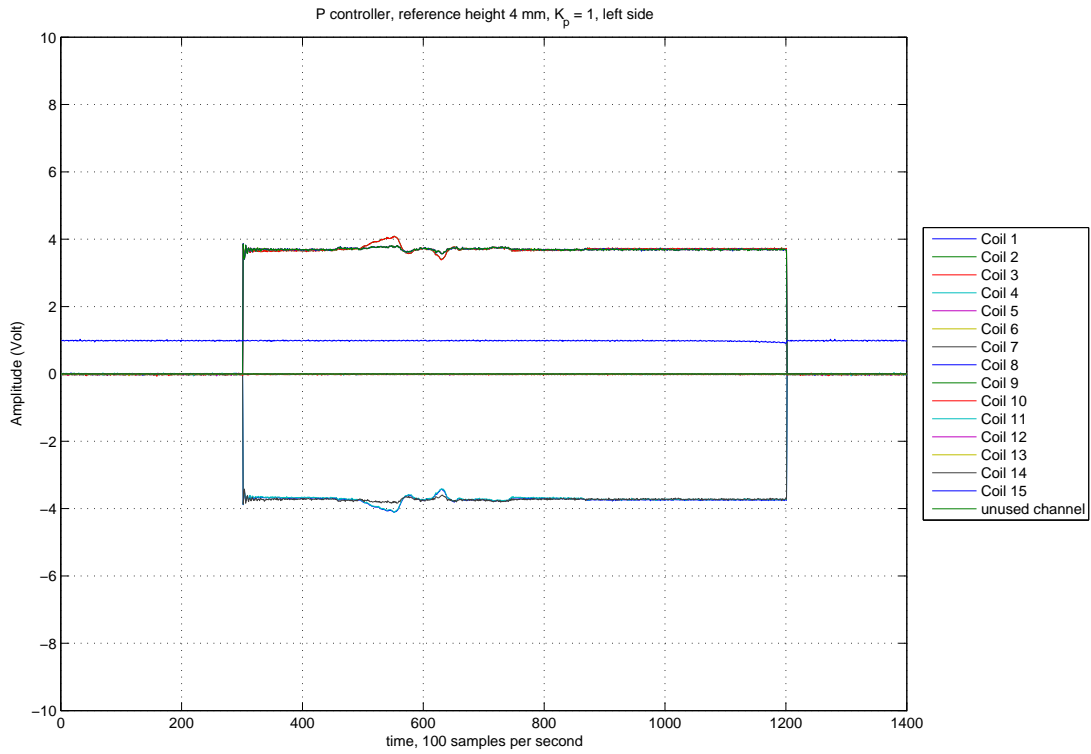

Figure 4.3: P control,  $K_p = 1$

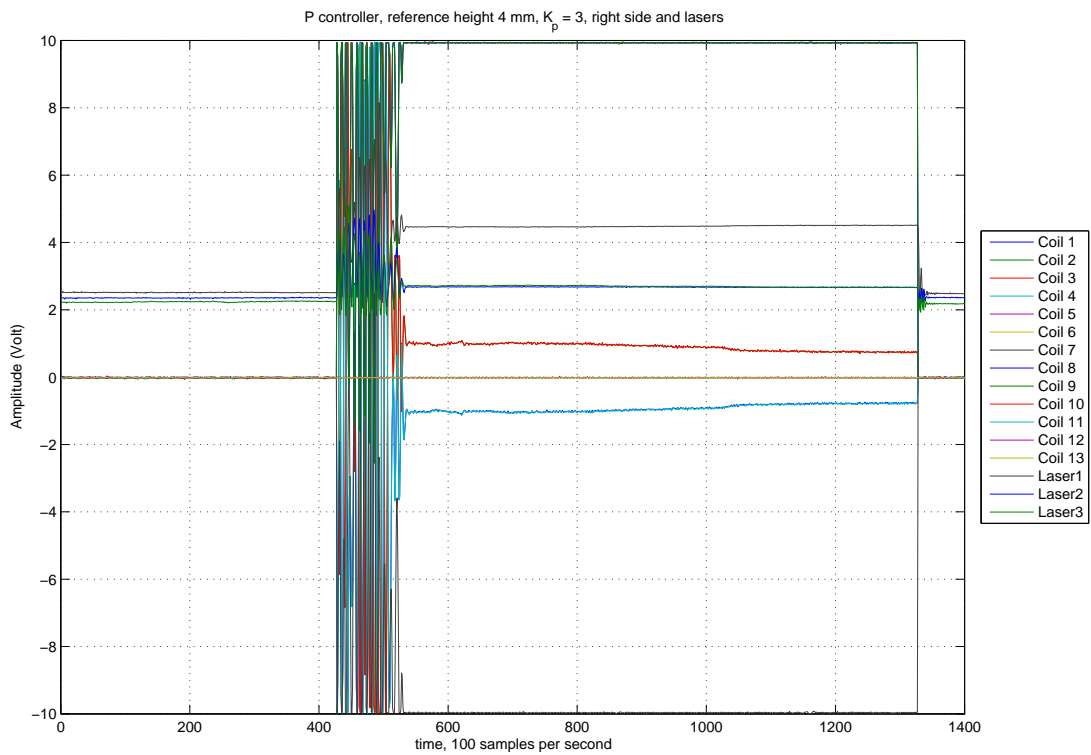

Figure 4.4: P control,  $K_p = 3$

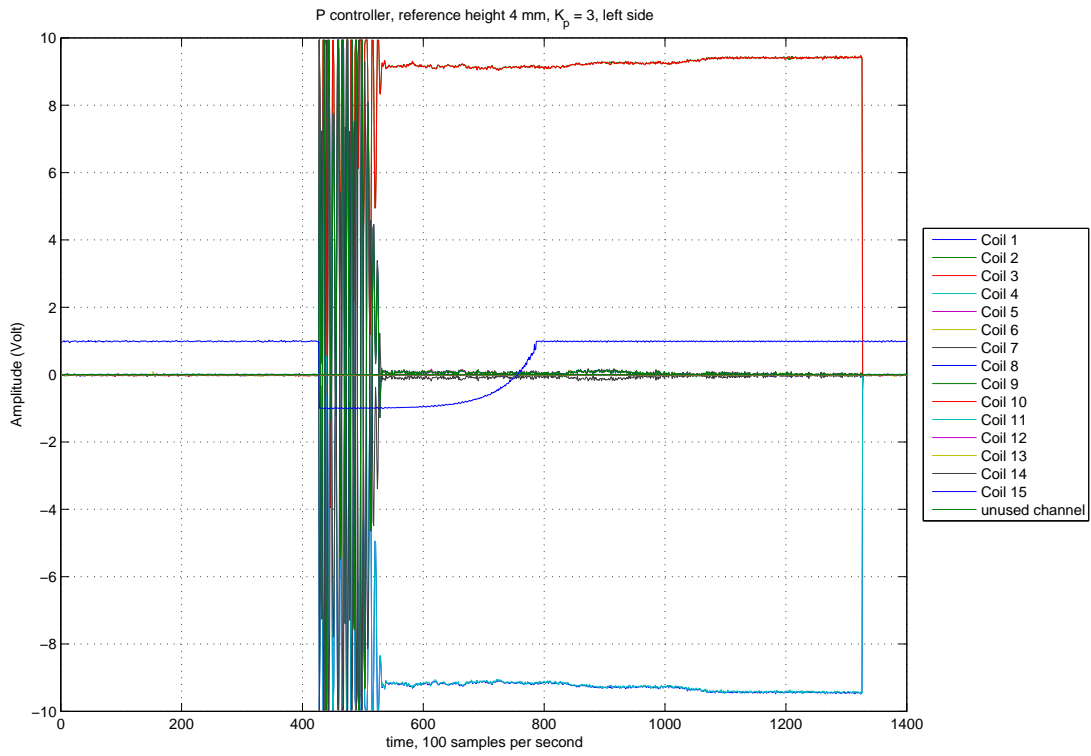

Figure 4.5: P control,  $K_p = 3$

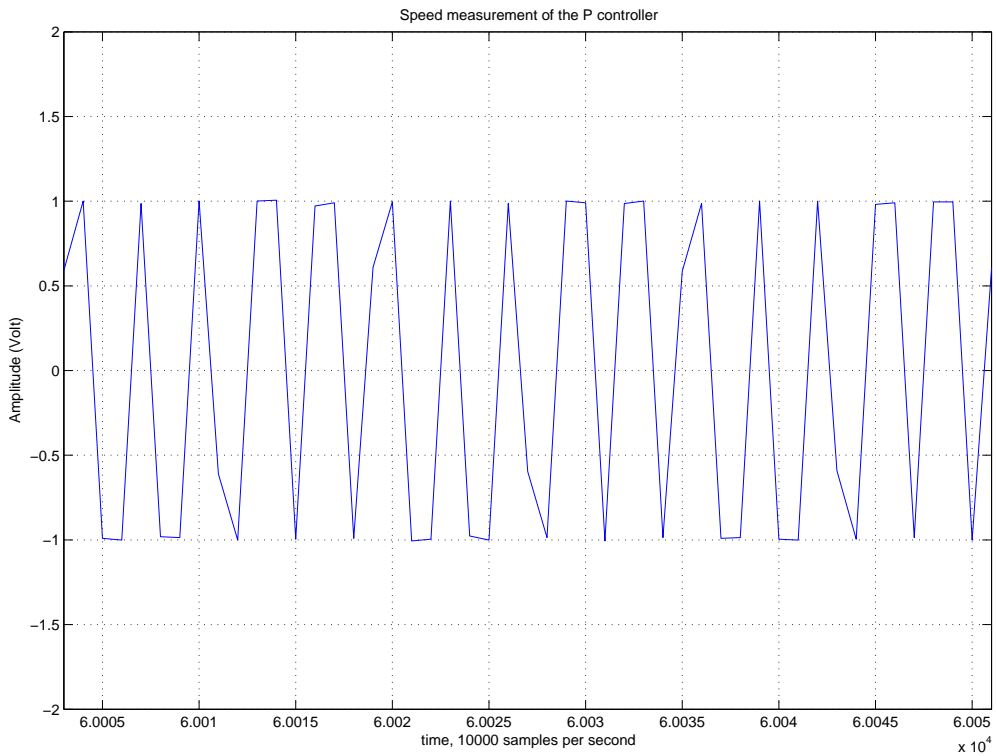

Figure 4.6: Testing the speed of the P controller



### 4.3 Proportional and Integral control

Figure 4.7 and figure 4.8 show the results obtained with a PI controller using a  $K_p$  of 1 and a  $K_i$  of 0.5. Still the performance is poor; the desired height is not reached and the sled also rolls and pitches. But this graphs shows that basic reaction of the controllers is correct;

- In the beginning the current is increased very fast, this is due to the P action (up to sample 300).
- When the error is below a certain value the effect of the P action becomes too small, now we see the output of the coils increase more slowly. This is due to the I action of the controller (after sample 300).

These graphs also shows the main disadvantage of four separate controllers. While the current through some coils is 10 A, which is the maximal value possible, other coils only conduct 3 or even 0.5 A. This is because the different controllers influence each other. If, for instance, quadrant one and three are lifted due to their own control output, quadrant two and four will also be lifted and thus send a lower current to their own coils.

The speed of this controller was determined using the same method as with the proportional controller, see figure 4.9. Taking the average of the pulse lengths leads to a frequency of approximately 4.166 KHz.

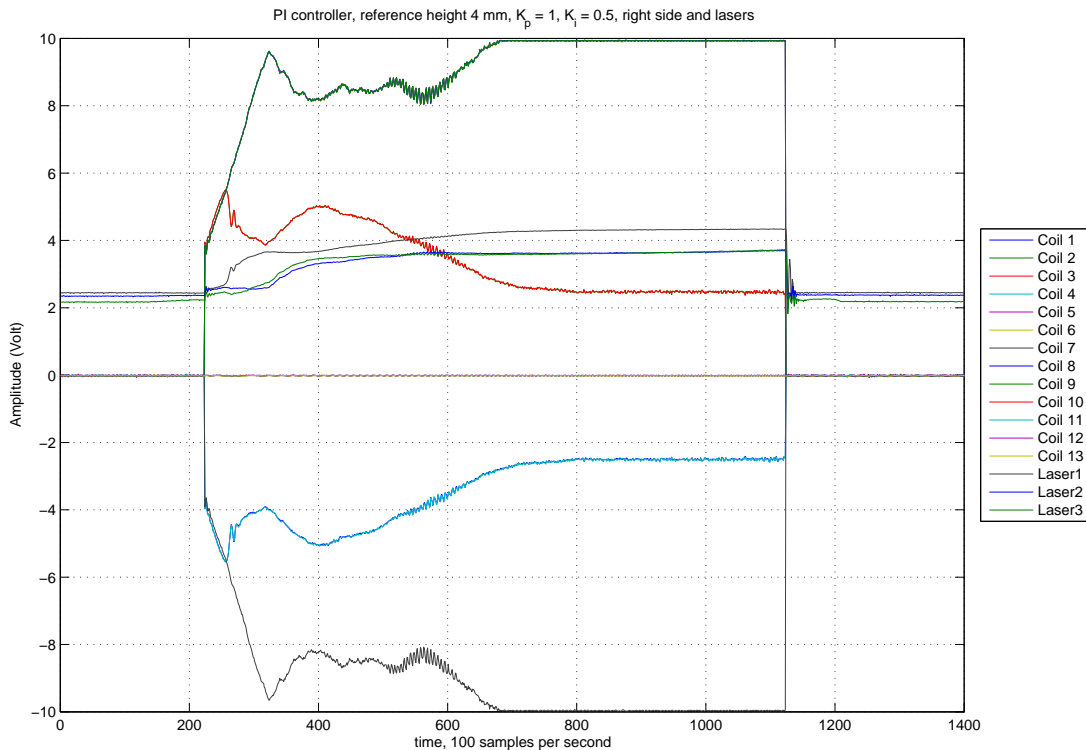

Figure 4.7: PI control,  $K_p = 1$ ,  $K_i = 0.5$

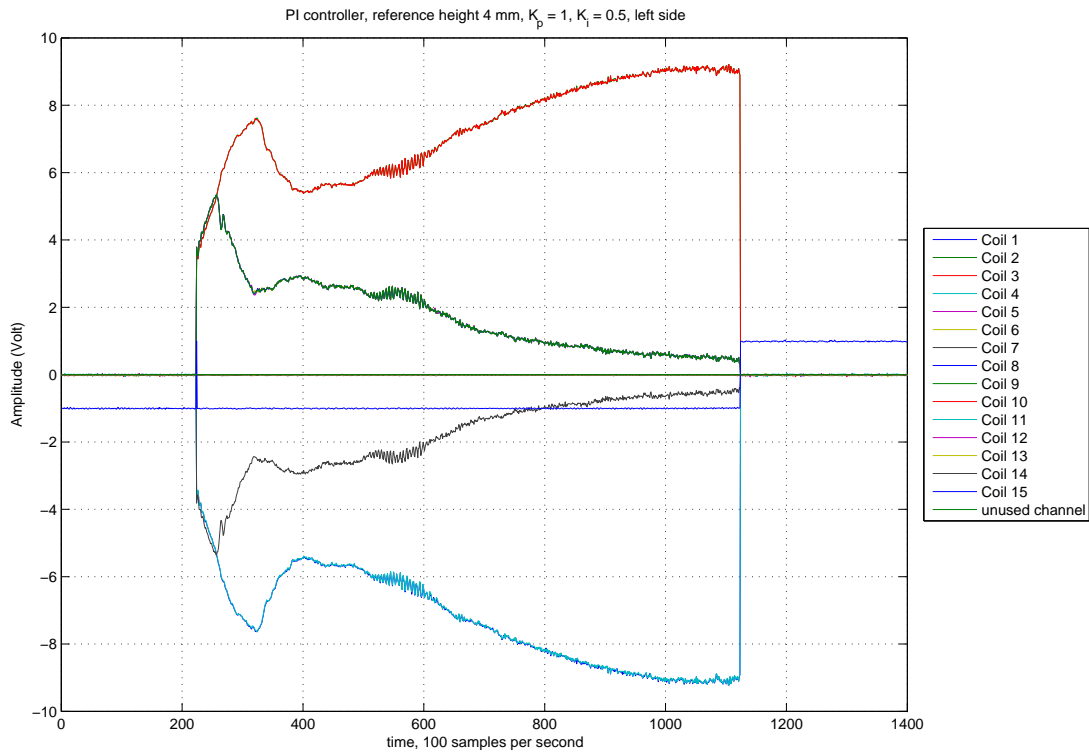

Figure 4.8: PI control,  $K_p = 1$ ,  $K_i = 0.5$

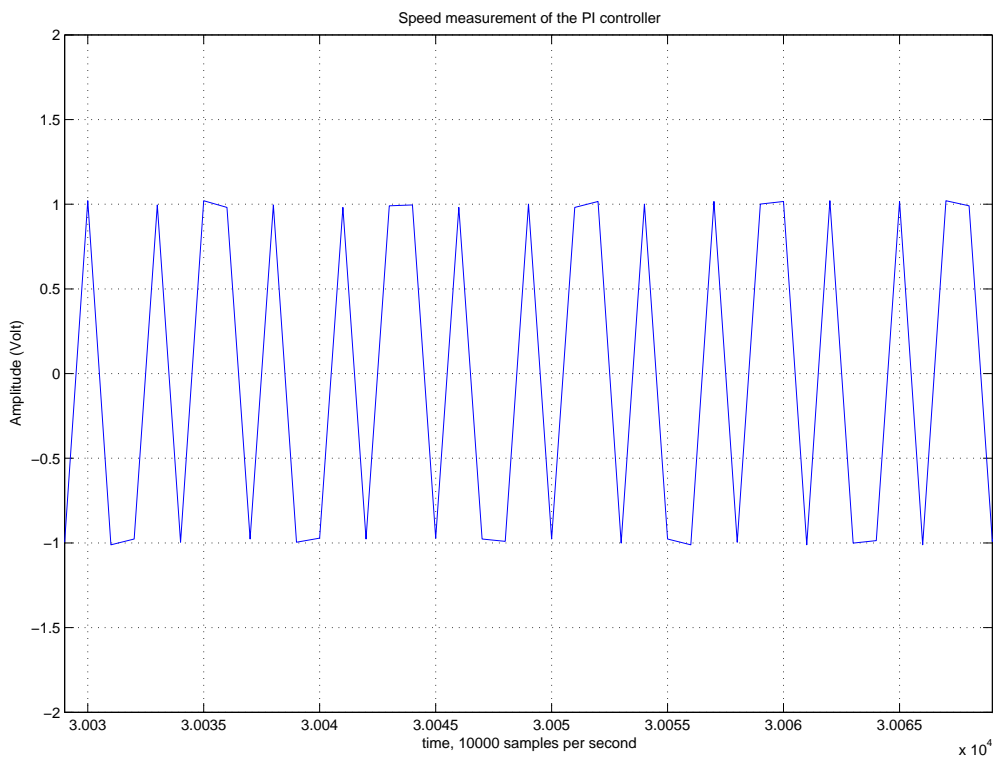

Figure 4.9: Testing the speed of the controller

## 4.4 Proportional, Integral and Differential control

Now I have added the differential action. With the differential action, the controller becomes unstable very fast. This is logical; the system starts to act to the noise in height measurement. See figure 4.10 and figure 4.11. Again an uneven distribution of the currents can be seen. The noise on the currents and the small vibration in the laser readings is caused by the differential action. The laser output is very stable after 5 seconds (500 samples). Here the sled is levitated a little over 3 mm at the front and a little under 3 mm at the back. When we look at figure 4.11 we see that the current through some of the coils go to zero. This again shows the disadvantage of the four separate controllers. The speed of this controller was determined to be approximately 3.333 KHz, see figure 4.12.

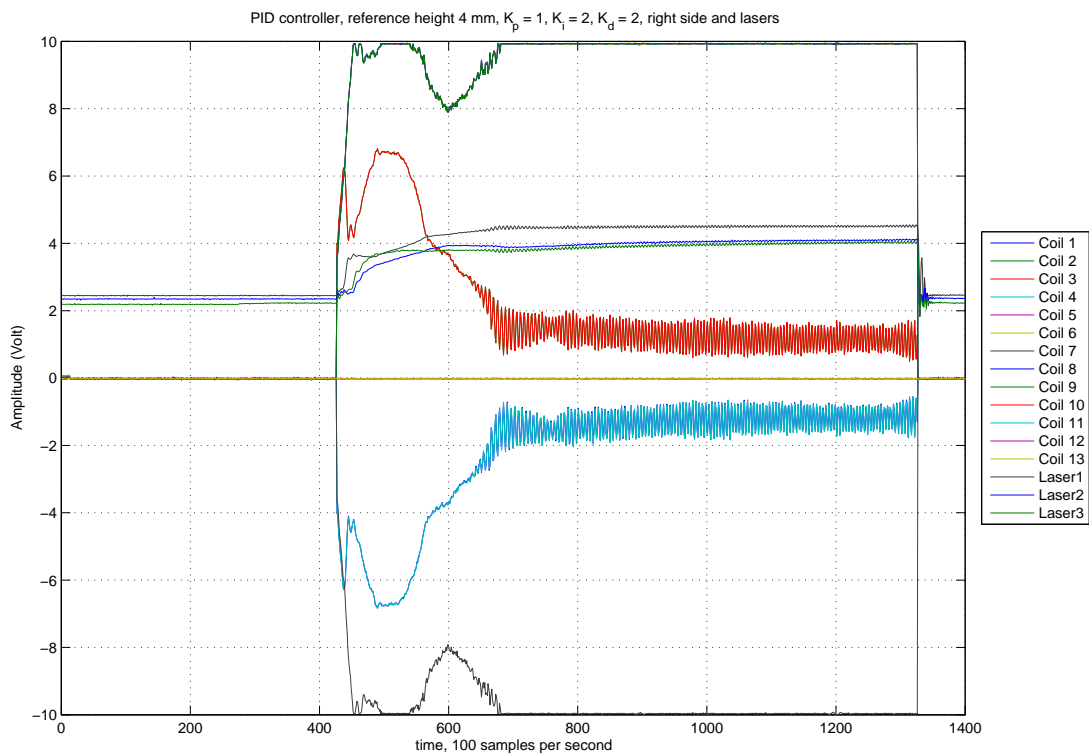

Figure 4.10: PID control,  $K_p = 1$ ,  $K_i = 2$ ,  $K_d = 2$

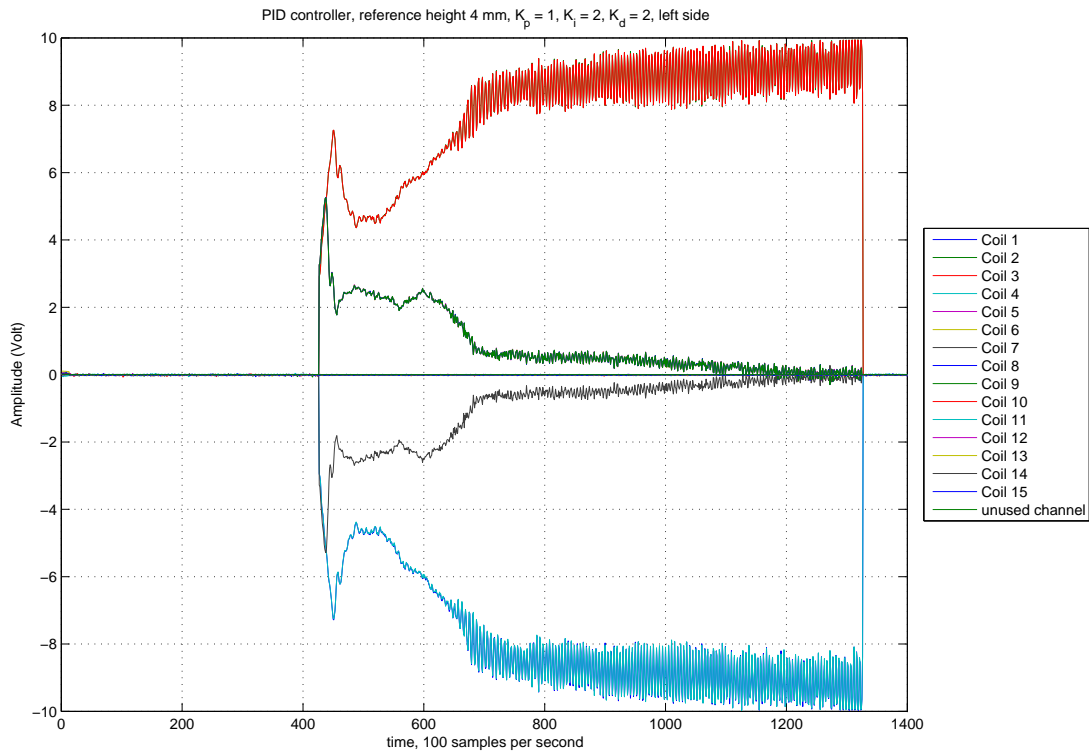

Figure 4.11: PID control,  $K_p = 1$ ,  $K_i = 2$ ,  $K_d = 2$

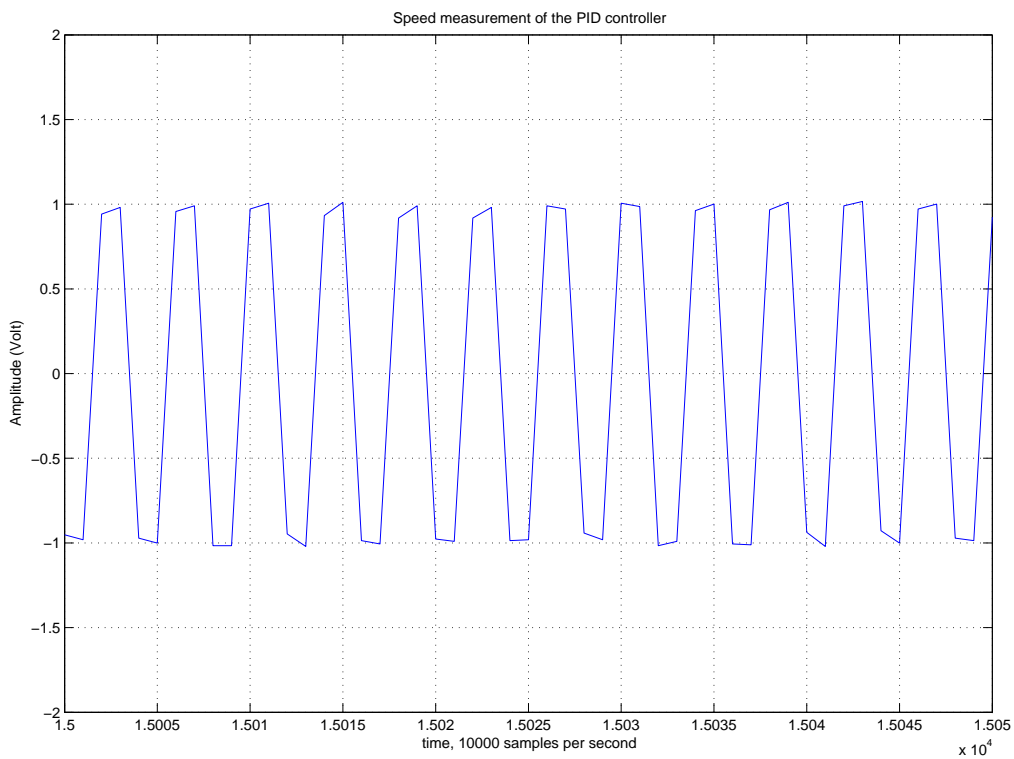

Figure 4.12: Testing the speed of the controller

# Chapter 5

## Wireless

Due to hurricane Jeanne the MAGLEV track laboratory was damaged and personnel was not allowed in the building until repairs were finished, which could last up to three weeks. Therefor I started working on a wireless connection for the sled. A wireless connection for the sled was already made by another student but this system did not work. Therefor a new concept was made.

A wireless connection has a mayor advantage being that the sled can move freely. A disadvantage, though acceptable, will be a weight increase of the sled making the system slower.

Due to the limited amount of time available the wireless connection had to be simple to build. This led to the use of commercially available products and a simple as possible design. Due to the limited amount of available funding for the project the wireless connection had to be as cheap as possible.

### 5.1 The first concept, not multiplexed

I chose for a wireless TV/audio transmitter/receiver set produced by Radio Shack. See appendix 1 for the technical details. Because this system is capable of transmitting TV signals its bandwidth is more than sufficient to transmit at least one laser signal and if needed (and this is the case as we will see later on) more. If the sled is not moving the output of the lasers is constant. Due to the fact that constant signals are transmitted poorly by the TV/audio transmitter a voltage to frequency converter is used. Figure 5.1 shows the schematic used for the transmitter and figure 5.2 shows the schematic of the receiver. See annex 2, 3 and 4 for technical details on the separate components and to determine the values of the used capacitors and resistors. we used a voltage to frequency factor of 25000. So 2 Volt should give a frequency of 50 KHz.

Figure 5.3 shows the test setup used to test the wireless connection. Two of the three transmitters had a constant voltage as input. The third transmitter had an actual laser as input. The input voltages were converted to frequencies and then transmitted. At the receiver side the received frequencies were measured. Figure 5.4 shows the results. from this we can conclude that with three separate transmitters and receivers the lasers signals are transmitted with adequate accuracy.

The voltage to frequency and the frequency to voltage conversion was also tested and func-

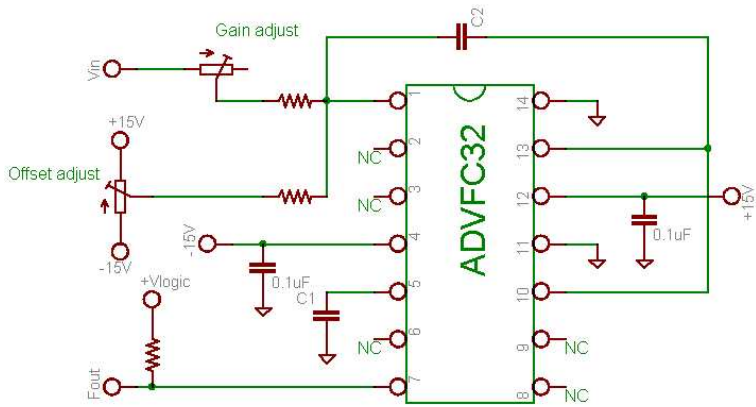

Figure 5.1: Transmitter used for one laser

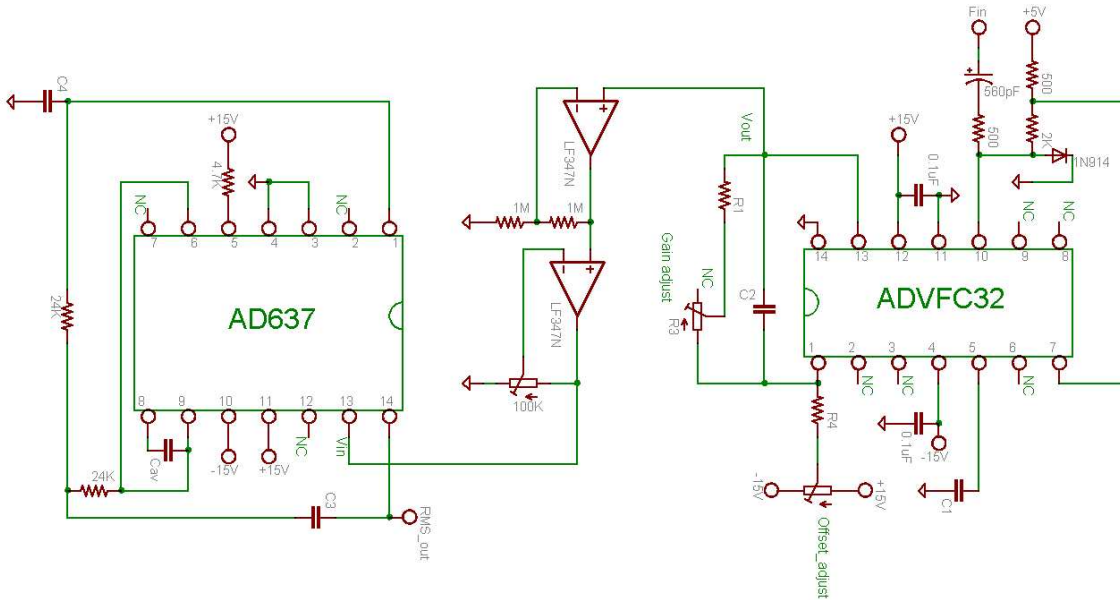

Figure 5.2: Schematic of the receiver of one laser signal

tioned very well. No test results are presented here because the schematics used are taken directly from the datasheets of the used chips. An additional advantage of this wireless connection is its filtering property, the noise levels on the laser signals are decreased considerably.

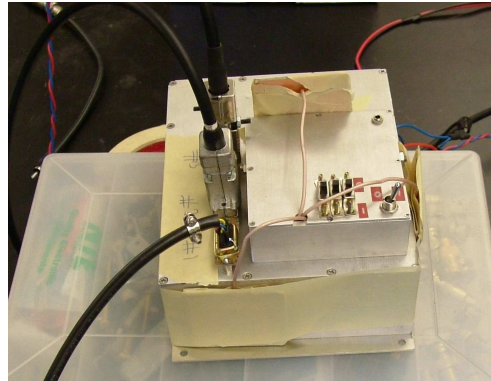
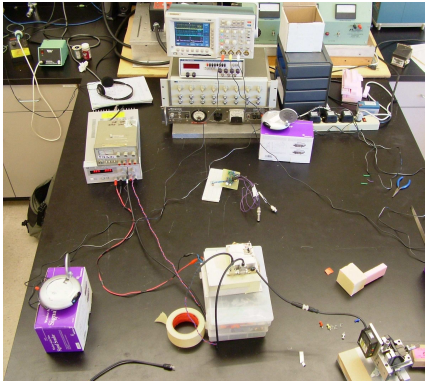

Figure 5.3: Test setup of the wireless connection

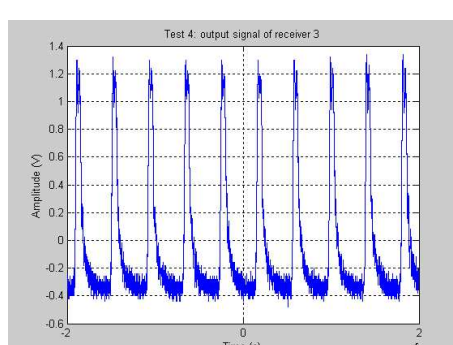
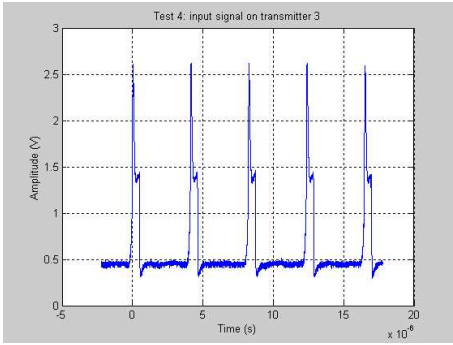
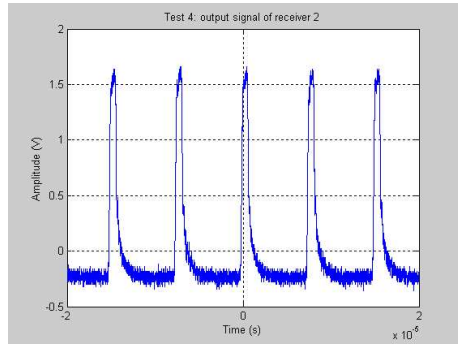
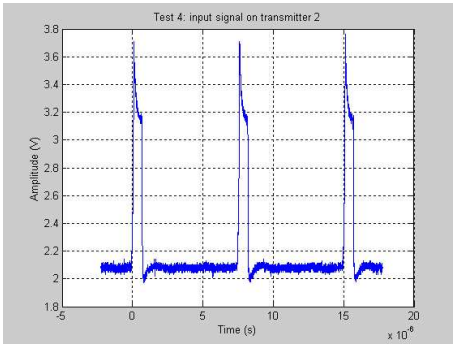
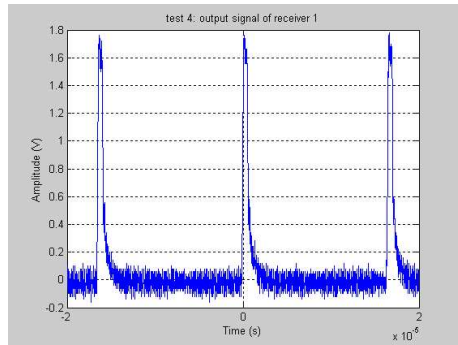
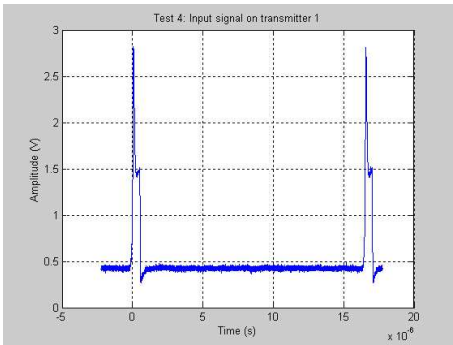

Figure 5.4: In- and output of the three transmitter/receiver sets

## 5.2 The second concept, multiplexed

A problem arose when applying this setup to the sled. In the MAGLEV laboratory an undefined interference source is present which prevents three of these transmitters to function at the same time. A single transmitter functions as expected, two sets can function simultaneously but with three sets two receivers receive the signal of the same transmitter thus causing the unacceptable loss of one signal. I have not been able to find the source of the interference. To solve this problem a new, slightly adjusted concept was used, see figure 5.5. The general idea is to multiplexed the three laser signals and then transmit them with one single transmitter. Therefore the output voltages of the three lasers are scaled. After scaling the output of the lasers will be as follows;

Table 5.1: Voltage ranges of the multiplexed lasers

Laser number	Voltage range after multiplexing (Volt)	Frequency range during transmission (KHz)
1	0.4 - 2	50 - 250
2	3.4 - 5	300 - 500
3	6.4 - 8	550 - 750

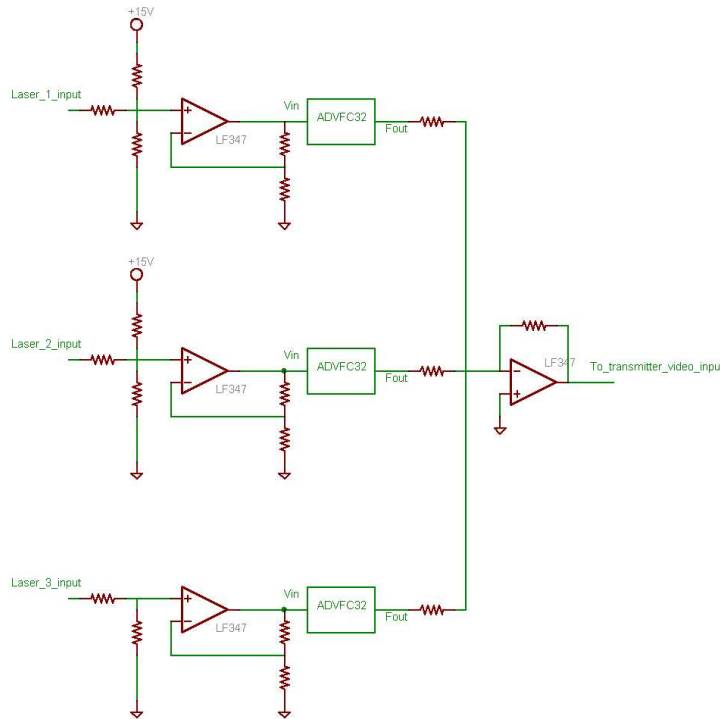

Figure 5.5: Schematic of the second transmitter concept; scaling the laser outputs, convert them to frequencies and multiplex them.

These frequencies are still within the bandwidth of the transmitter/receiver set. The spacing



of 50 KHz between the three different signals should give enough space to separate the signals at the receiver side with band-pass filters. After each band-pass filters a frequency to voltage converter and a RMS to DC converter as in the previous setup can be used. An advantage of this setup will be a decrease in weight and energy consumption of the transmitter on the sled.

Because my time to work on the transmitter ended, this work was passed to an FIT student.

## Chapter 6

# Proposed improvements

In this chapter I suggest improvements for the track. The improvements concern the current hardware.

The nine amplifiers of the linear motor still have a weakness. I have not spend a lot of time on this but I am sure that these nine power supplies still have a weak spot. On all the power supplies a small component was found with shrink tubing which showed deterioration due to high heat levels. The amplifiers should be checked and, if needed, revised.

Most of the experiments done are at low speed. With these slow experiments the difference in switching speed (from low to high output and from high to low output) of the sensors is insignificant. A metal plate of which the holes have the same width as the fins might give better results. For fast experiments the original plate can be used.

The controller and PWM boards have significant noise levels which will become an issue with more demanding tests. A well thought out grounding plan, shielded cables can reduce these levels of noise.

The levitation logic boards can be damaged by signal build up from the pulses. A pulse send out by the nineteenth sensor board travels through all the boards. In some cases this leads to signals with such a high amplitude that the destroy the sensor boards. This can be prevented by separating the different levitation logic boards with opto couplers on these pulses lines.

The performance of the levitation amplifiers is adequate. Still during experiments they have to be treated with care. They heat up very fast and need time to cool down. A more effective cooling of the amplifiers, for instance with large fans, reduces the chance of destroying an amplifier and allow the user to perform slightly longer experiments.

The mounting of the levitation coils must be improved. The freedom of movement the levitation coils have right now is intolerable. This movement can not be modelled and it is impossible to correct for it in the software of the DSP due to limited calculation time.

The mounting of the coils can be improved by using epoxy and thereby solidly connecting them to the plastic walls, see figure 6.1.

The levitation sensor boards consist of two PCBs with a square wooden stick between them. The original sensor boards have two blank electrical wires running between the two PCBs over this wooden stick. When the sled passes, the metal plate passing through the sensor can touch these metal wires, cause a short circuit and damage the electronics. A simple method to prevent this is to replace the two wires with two wires that run around the two sensor boards. With some of the sensor boards this is already done.

The noise on the output of the lasers can be reduced by using good reflective tape. During tests the mounting brackets of the lasers were not ideal to work with. These brackets could be replaced with better brackets.

The second concept of the wireless is very promising. Implementing this concept free's the sled and reduces noise. The increase in weight, which is smaller than with the first concept (1.5 Kg including battery and casing), is more than acceptable.

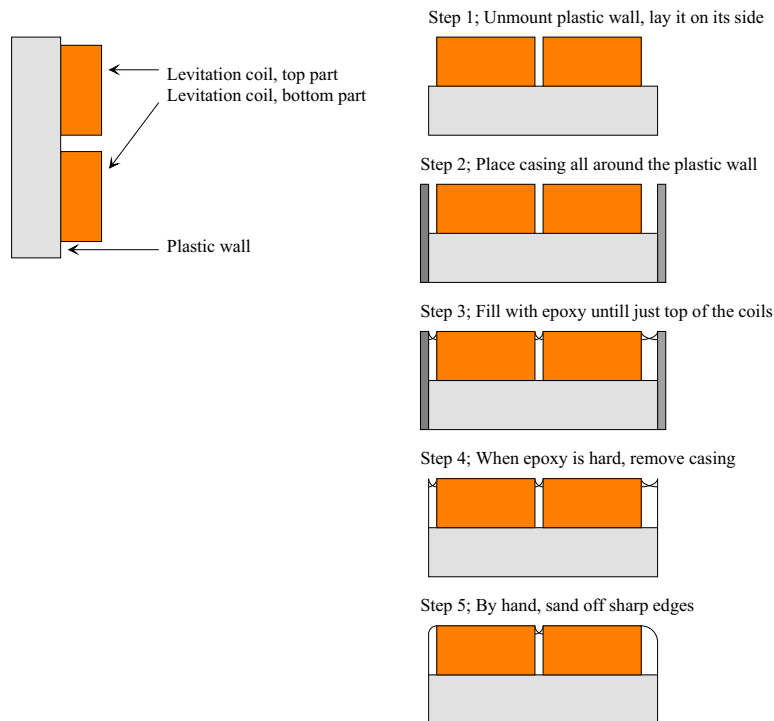

Figure 6.1: Mounting the coils with epoxy

## Chapter 7

### conclusion

The track works as needed, this is shown by the tests. But it does have its deficiencies and it is not likely that in the current state the track will be able to perform at the level it was actually build for. Improvements can be made, with little cost, to improve the tracks performance. The system is able to levitate the sled, but without forward movement. And I am convinced that Jeroen's experiment can be repeated. I have not succeeded in doing this because of lack of time. The wireless second concept is a good basis for a new wireless connection for the sled.