

Integrating design and manufacturing

Citation for published version (APA):

Delbressine, F. L. M., & van der Wolf, A. C. H. (1990). Integrating design and manufacturing. *CIRP Annals*, 39(1), 149-152. [https://doi.org/10.1016/S0007-8506\(07\)61023-3](https://doi.org/10.1016/S0007-8506(07)61023-3)

DOI:

[10.1016/S0007-8506\(07\)61023-3](https://doi.org/10.1016/S0007-8506(07)61023-3)

Document status and date:

Published: 01/01/1990

Document Version:

Publisher's PDF, also known as Version of Record (includes final page, issue and volume numbers)

Please check the document version of this publication:

- A submitted manuscript is the version of the article upon submission and before peer-review. There can be important differences between the submitted version and the official published version of record. People interested in the research are advised to contact the author for the final version of the publication, or visit the DOI to the publisher's website.
- The final author version and the galley proof are versions of the publication after peer review.
- The final published version features the final layout of the paper including the volume, issue and page numbers.

[Link to publication](#)

General rights

Copyright and moral rights for the publications made accessible in the public portal are retained by the authors and/or other copyright owners and it is a condition of accessing publications that users recognise and abide by the legal requirements associated with these rights.

- Users may download and print one copy of any publication from the public portal for the purpose of private study or research.
- You may not further distribute the material or use it for any profit-making activity or commercial gain
- You may freely distribute the URL identifying the publication in the public portal.

If the publication is distributed under the terms of Article 25fa of the Dutch Copyright Act, indicated by the "Taverne" license above, please follow below link for the End User Agreement:

www.tue.nl/taverne

Take down policy

If you believe that this document breaches copyright please contact us at:

openaccess@tue.nl

providing details and we will investigate your claim.

Integrating Design and Manufacturing

F. L. M. Delbressine, A. C. H. van der Wolf (1); TNO Institute of Information-Technology for Production Automation
Received on January 15, 1990

This paper deals with concepts needed to integrate design and manufacturing of mechanical products. Their power springs from the enforcement of manufacturing restrictions at the geometrical design stage, which ensures a guarantee that a design generated according to the method described, has the intrinsic possibility of being fabricated. Furthermore, the concepts offer the rapid generation of manufacturing process plans. Thus the time taken to traverse the path between design and manufacture is substantially reduced.

Keywords: Design, CAD-CAM.

1 Introduction

The current approach to the market requires short production runs, a greater product range, and a reduction in throughput time. These requirements in their turn impose the need for a less time-consuming path from design to manufacture.

2 The Design process

The aim of the design function is the translation of the functional specification of a product into a product that can perform the desired function(s).

Within the context of this article, the design function is considered to consist of two phases: first the conceptual phase, in which the need for a product is transformed into ideas; and then the geometrical phase, in which the ideas are translated into a design. The conceptual phase results in a set of possible solutions to the problem posed. These are then evaluated and validated within the context of the following phase. The geometrical phase deals with physical function, form, fit, tolerance, weight, stiffness and so on. Since the conceptual phase is in large measure a creative and an inventive process, it cannot readily be formalized. Therefore, it should be left out of account in any attempt to integrate design with manufacture. The primary purpose of the geometrical phase of the design process is the generation of an unambiguous, complete representation of the product; one, furthermore, that can be manufactured. Besides this, the representation must be suitable for use as input to other, down-line functions, such as the manufacturing planning function. The requirement that a product representation must represent a product that is capable of being manufactured necessitates the enforcement of manufacturing restrictions at the geometrical stage of the design process. The question then inevitably arises: what kind of manufacturing restrictions are relevant, and how may they be utilized? The major manufacturing restrictions are those due to forms that cannot be fabricated, and these fall into three categories: those that cannot be made, no matter what technology or equipment is used; forms that cannot be manufactured by a specific technology; and forms that cannot be manufactured by a specific machine or equipment. The notion that a given form cannot be manufactured, no matter what technology, process or equipment is used, is a limitation that is more apparent than real since, given suitable materials, the inventiveness of the human mind permits the fabrication of virtually any conceivable form. An example of a form that cannot be fabricated by a specific technology is presented in Figure 1. The cavity cannot be milled, on the assumption that the tolerances specified are much smaller than the radius of the smallest available mill, since two of the corners are not rounded.

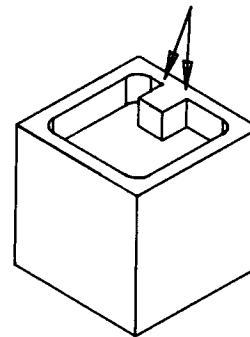

Figure 1. A cavity that cannot be milled

The piece could be fabricated by electrospark erosion, however. The final category – forms that cannot be fabricated by a specific machine or equipment – is of minor importance when determining whether a design can be manufactured.

If one assumes that almost all geometrical forms can be constructed by using a limited number of basic objects, then the second category allows the use of a structured approach to the enforcement of manufacturing restrictions in the design phase. These basic objects, defined as geometrical forms that can be manufactured, are called Manufacturable Objects. One can only establish empirically that a geometrical form is a Manufacturable Object. The Manufacturable Object concept is the design and manufacturing planning counterpart of the application of a combination of one or more tools, machines and setups in the manufacturing phase. Examples of Manufacturable Objects are cavities, slots, shapes obtainable by bending, or assemblies. The concept of a Manufacturable Object consists of two geometrical forms, the initial geometrical state and the final geometrical state, together with a set of application rules. These rules ensure that the Manufacturable Object can be applied and, thus, that a design can be manufactured.

There are two distinct aspects to the notion of a Manufacturable Object: one relating to the geometrical design and one to the manufacturing process planning. In the geometrical design phase it is only necessary to be certain that a Manufacturable Object has stated initial and final geometrical forms and that it can indeed be fabricated. In the manufacturing planning process, however, it is not the initial or the final state that are important, but rather the way in which that final state can be achieved given the initial state.

In the design phase certain parameters relevant to the accuracy achievable with a given Manufacturable Object must be available, such as surface roughness and fit. This

may be achieved by the incorporation, within the design approach, of a model that 'knows' the accuracy of which the machine is capable to manufacture and that 'knows' how each Manufacturable Object must be fabricated according to its specifications. The concept, which introduces the available machinery and equipment in the design phase, has been called the Manufacturing Machine Model concept. It is thus a formalization of the manufacturing abilities of a given type of manufacturing machine including its tools and workpiece setups.

Every manufacturing process, such as turning, milling, and so on, generates surfaces, so another consequence of the demand that the product description that is produced in the geometrical design phase must be capable of fabrication is that surfaces have to be dealt with in the design phase. Edges and vertices are by-products of the fabrication of surfaces. The requirement that a product description must be suitable as input to other, down-line functions, combined with the requirement that the geometrical design phase must generate a description of a product that can actually be fabricated, imposes a certain requirement on the internal geometrical representation of the design. The manufacturing function and, thus, the manufacturing process planning function, needs a representation that is based on the initial state of the product and the changes through which the various phases of the design pass on the way to the realization of the final object. The manufacturing function transforms raw material through a succession of operations, which are specified in the state description emanating from the geometrical design phase.

The two for the present purposes most promising design representations are Constructive Solid Modelling and Boundary Representation. Boundary Representation is a method for describing a physical solid object in terms of its topological boundary. This boundary is divided into a finite number of faces, each of which can be defined in turn in different ways. One popular method is the representation of each face in terms of its boundary edges and vertices (1).

Since manufacturing processes generate surfaces, the Boundary Representation comes closest to a geometrical model that is directly suitable for input to the manufacturing process planning. However, it has one major drawback: it is a final state description of the object to be fabricated. Only the final state of the design is passed on to the manufacturing process planning phase, and so the manufacturing process plan, which is required for the fabrication of the final state, must be generated ab initio.

Constructive Solid Modelling is based on the fundamental concept that a solid object can be represented as a series of additions and subtractions of various simpler solids. A representation of a physical solid object can be visualized in the form of a tree structure the leaves of which are primitive solids, the branches being nodes where operations are performed on the solids. One disadvantage of this method of representing the design of products is that it is possible to generate a representation that bears no relationship to the operations required for its manufacture. Another disadvantage is that no representation of faces is available, except in the primitive solid model, and so a design representation that has to deal with manufacturing restrictions, based on the Constructive Solid Modelling technique alone, is useless. It has to be converted to a Boundary Representation.

2.1. Manufacturing-Oriented Design

Neither of the design representations discussed above is suitable for our purposes by itself. When modified and

combined, however, a suitable representation can be contrived. The Manufacturing-Oriented Design representation proposed here is such a modelling technique. The Boundary Representation is updated after each operation, and each operation performed is stored in the Constructive Solid Modelling tree. One of the modifications to the Constructive Solid Modelling representation is that each design transformation, each node of the tree, requires a manufacturable counterpart.

In order to be able to handle manufacturing restrictions, Manufacturing-Oriented Design must be supplemented with the concepts of Manufacturable Objects, Manufacturing Machine Models, and Implicit Locating. As has been explained, a Manufacturable Object is a geometrical form which, it has been demonstrated, can be fabricated. The Manufacturing Machine Model concept handles the part of the manufacturing restrictions that depend on the equipment used.

We have not yet dealt with two kinds of manufacturing restrictions: tolerances and fits. In order to deal with the design counterparts of the limitations on manufacturing accuracy the concept of Implicit Location is introduced. An Implicit Location specifies the location (position and orientation) of a solid object or a Manufacturable Object with constraints relative to another solid object. Examples of these constraints are faces that have to meet, edges and vertices that have to coincide, or a peg that has to be inserted in a hole. The main advantage of the Implicit Location concept lies in the fact that tolerances and fits can be dealt with functionally, as they are in the product's manufacturing phase. This allows the location of the physical solid or the Manufacturable Object, as specified by the restraints. Furthermore, it allows for the identification of the manufactured referential objects. The Implicit Locating concept also allows to generate corrections in the location and/or shape of a Manufacturable Object during the course of fabrication and it allows for the automatic generation of measurement programs.

3 The Manufacturing Process Planning

Two basic types of manufacturing process planning may be distinguished: the retrieval type and the generative type. Retrieval planning is based on group technology methods, by which manufacturing parts are coded and classified into family groups. A very powerful type of retrieval planning is described in the paper of Peters and Van Campenhout (4). The generative type of planning generates a new manufacturing process plan for every part ab initio. This type of planning uses mathematical models for the description of the selection process (6). The generative type of manufacturing process planning is far more powerful than the retrieval type, since the latter is limited by the number of predefined groups. Unfortunately, generative planning requires human inventiveness, and this cannot yet be formalized, which means that human intervention will necessarily be associated with generative planning, at least for the foreseeable future.

The concepts of Manufacturing-Oriented Design introduced above, do facilitate the preparation of a manufacturing process plan, in that five of the concepts incorporated in Manufacturing-Oriented Design the Constructive Solid Modelling tree of a geometrical design, the Manufacturable Objects, the Manufacturable Transformations, Implicit Location, and the Manufacturing Machine Models are relevant to the preparation of a manufacturing process plan.

The Constructive Solid Modelling tree of a design includes the specification of the raw materials needed and the

transformations applied in the design phase. Each design transformation can be a Manufacturable Transformation, an Implicit Location, or the application of a Manufacturable Object.

As mentioned before the application of a Manufacturable Object is the design and manufacturing process planning counterpart of the application of one or more tools, machines and setups in the manufacturing phase.

A Manufacturable Transformation is a design transformation which has a manufacturable counterpart. An example of a Manufacturable Transformation is the welding together of two parts by a robot.

The Implicit Location concept has been introduced in order to deal with the limitations on manufacturing accuracy in a functional way in the design phase. An Implicit Location specifies the location (position and orientation) of a solid or a Manufacturable Object with constraints relative to another solid object.

As has been mentioned above, each manufacturing machine available has a model, the Manufacturing Machine Model. The model of a manufacturing machine knows if the corresponding manufacturing machine is capable of executing a design transformation. If the machine is capable of executing it, then the Manufacturing Machine Model knows, or is able to calculate, which combinations of setups, tools and fixtures is suitable for its execution. Furthermore, the Model is able to determine the manufacturing conditions and to generate the necessary tool paths. It also allows the simulation of the machine and the product while generating the tool paths.

The Constructive Solid Modelling tree can thus be used as a guide for the generation of a manufacturing process plan. It can be regarded as a high level outline of the manufacturing process plan. Optimization may require a change in the sequence in which the design transformations are applied which may, in turn, lead to an intermediate state that cannot be manufactured. Since our objective is to take explicit account of manufacturing limitations, it is good practice not to change the order in which transformations are executed, unless one is perfectly certain that the changed sequence can in fact be executed and will produce the required product.

The concepts selected for incorporation in Manufacturing-Oriented Design categorize the manufacturing process planning phase as a powerful type of retrieval manufacturing process planning.

It may be that, during the development of a manufacturing process plan, the implementation or execution of a number of Manufacturable Objects will cause a degree of mutual interference. Under such circumstances it would probably be possible to devise a more economical manner to execute the Manufacturable Objects. Minimization of the cost of production depends rather on the batch size or production run contemplated, but no attention has been paid to optimization problems of this type.

4 A typical example

The example product is depicted in Figure 2. The design of the product commenced with the copying of a primitive cube, followed by resizing it to a side length of 80mm. The next step in the design phase was the application of a Manufacturable Object which removes all the material above a plane surface. The application is tested using the application rules belonging to the Manufacturable Object. The outcome of the application is revealed in Figure 3.

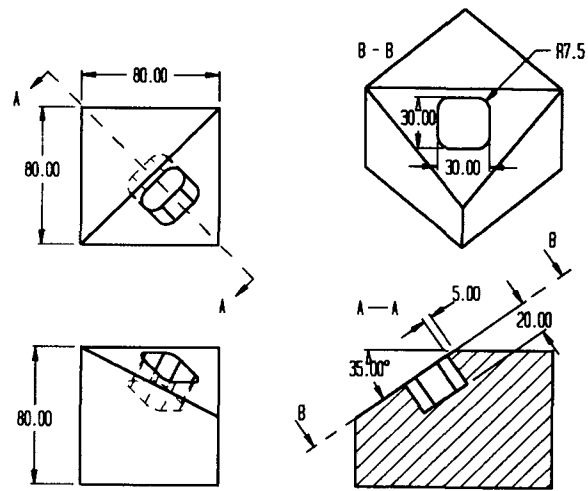

Figure 2. The product to be designed

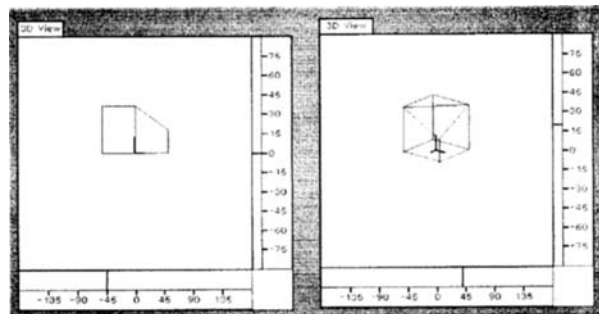

Figure 3. The result of the application

We now have to apply the Manufacturable Object that corresponds to the rounded cavity. The result is shown in figure 4.

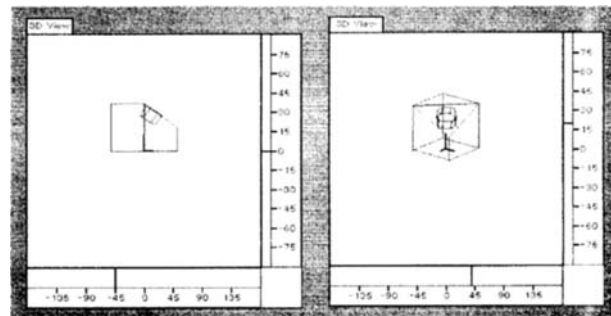

Figure 4. The final design result

All applied Manufacturable Objects have been located using Implicit Locating. The design of the product is now complete. Its design history, the Constructive Solid Modelling tree, is shown in Figure 5. This figure shows how the product has been designed. The top left-hand list is the history, the Constructive Solid Modelling tree of the design. The item selected in this list is the first 'ApplyManufacturableObject' operation. The type of manufacturable object applied, a PlanarMaterialRemoval, and the planar face equation, are shown in the bottom right-hand view.

The process of creating a manufacturing process plan for this product is performed by passing on the history of the design to the manufacturing process planning phase. Before doing this, however, a model of the workcell to be used has

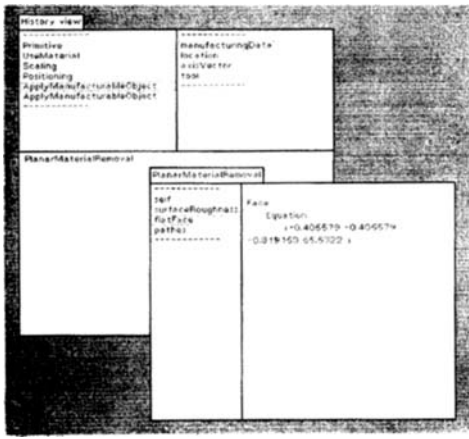

Figure 5. The history of the designed product

to be configured. This is necessary for the simulation and the validation of the manufacturing process plan that has been generated. After configuration of the workcell with the relevant machine(s) – in this case only a Maho 700S milling machine – the user interface appears. The next step is to use the Constructive Solid Modelling tree as a guide to generate the manufacturing process plan. The earlier items in the Constructive Solid Modelling tree (see Figure 5), up to the first 'ApplyManufacturableObject' item, represent a description of the initial, raw shape of the product to be manufactured. The next step, therefore, is the application of the planar material removal Manufacturable Object. Before it is applied, the Manufacturing Machine Model (of the machine selected) is interrogated to determine whether the machine and the available tools are capable of executing the operation chosen. After a suitable machine and tool have been selected, the tool paths needed to execute the planar material removal are generated and simulated, as shown in Figure 6.

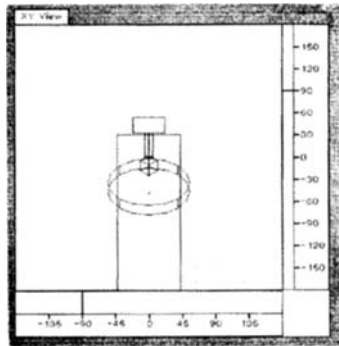

Figure 6. The simulation of the generated tool paths

The final step is the application of the Manufacturable Object to generate the rounded cavity. The manufacturing process plan generated can be transformed into one or more machine programs. The automatically generated machine program was used to activate the Maho 700S five axis milling machine, with the result shown in Figure 7.

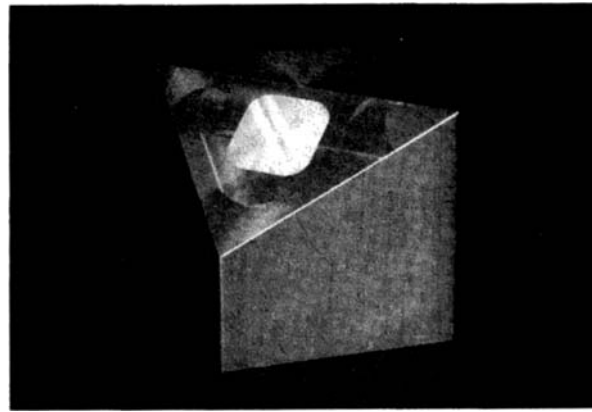

Figure 7. The manufactured product

5 Results and conclusions

The foregoing has introduced certain concepts for the integration of the design and manufacture of mechanical products. Their power springs from the enforcement of manufacturing restrictions at the geometrical design stage, which ensures a guarantee that a design generated according to the method described has the intrinsic possibility of being fabricated.

The Manufacturable Object concept is particularly important in the enforcement of manufacturing restrictions on the geometrical design, since Manufacturable Objects represent a formalization of what can actually be fabricated. The definition of new Manufacturable Objects, in particular their application rules, remains, unfortunately, a tedious task, since the generation of application rules formalizes the context-dependent knowledge of what can actually be fabricated.

The main advantages of the concepts introduced here are that they guarantee, at the geometrical design stage, that a design, once produced, can actually be manufactured. They also offer the rapid generation of manufacturing process plans, and they thus substantially reduce the time taken to traverse the path between design and manufacture.

A possible extension to the Manufacturing-Oriented Design methodology might be a link between functional elements (5), like gearboxes and bearings, to the concepts of Manufacturing-Oriented Design, like Manufacturable Objects and Implicit Locating. Such that an integration between functional design and manufacturing becomes possible.

- (1) Braid I.C., 1974, *Designing with Volumes*. Cantab Press, Cambridge, England.
- (2) Delbressine F.L.M., 1989, *On the Integration of Design and Manufacturing*, Ph. D. Thesis, Eindhoven University of Technology, Eindhoven, The Netherlands.
- (3) Erve van 't A.H., 1988, *Generative Computer Aided Process Planning for Part Manufacturing, An Expert System Approach*, Ph.D. Thesis, Twente University of Technology, Enschede, The Netherlands.
- (4) Peters J., Campenhout Van D., 1987, *Manufacturing Oriented and Functional Design*, *CIRP Annals*, 37/1, p. 153–156.
- (5) Schmekel H., 1989, *Functional Models and Design Solutions*, *CIRP Annals*, 38/1, p. 129–132.
- (6) Weill R., Spur G., Eversheim W., 1982, *Survey of Computer-Aided Process Planning Systems*. *CIRP Annals*, 32/2, p. 539–542.