

Partial discharges and the electrical aging of XLPE cable insulation

Citation for published version (APA):

Wolzak, G. G., Laar, van der, A. M. F. J., & Steenis, E. F. (1986). *Partial discharges and the electrical aging of XLPE cable insulation*. (EUT report. E, Fac. of Electrical Engineering; Vol. 86-E-160). Technische Universiteit Eindhoven.

Document status and date:

Published: 01/01/1986

Document Version:

Publisher's PDF, also known as Version of Record (includes final page, issue and volume numbers)

Please check the document version of this publication:

- A submitted manuscript is the version of the article upon submission and before peer-review. There can be important differences between the submitted version and the official published version of record. People interested in the research are advised to contact the author for the final version of the publication, or visit the DOI to the publisher's website.
- The final author version and the galley proof are versions of the publication after peer review.
- The final published version features the final layout of the paper including the volume, issue and page numbers.

[Link to publication](#)

General rights

Copyright and moral rights for the publications made accessible in the public portal are retained by the authors and/or other copyright owners and it is a condition of accessing publications that users recognise and abide by the legal requirements associated with these rights.

- Users may download and print one copy of any publication from the public portal for the purpose of private study or research.
- You may not further distribute the material or use it for any profit-making activity or commercial gain
- You may freely distribute the URL identifying the publication in the public portal.

If the publication is distributed under the terms of Article 25fa of the Dutch Copyright Act, indicated by the "Taverne" license above, please follow below link for the End User Agreement:

www.tue.nl/taverne

Take down policy

If you believe that this document breaches copyright please contact us at:

openaccess@tue.nl

providing details and we will investigate your claim.

Eindhoven University of Technology Research Reports

EINDHOVEN UNIVERSITY OF TECHNOLOGY

Department of Electrical Engineering

Eindhoven

The Netherlands

PARTIAL DISCHARGES AND THE ELECTRICAL
AGING OF XLPE CABLE INSULATION

by

G.G. Wolzak

A.M.F.J. van de Laar

and

E.F. Steennis

EUT Report 86-E-160

ISBN 90-6144-160-9

ISSN 0167-9708

Coden: TEUEDE

Eindhoven
November 1986

CIP-GEGEVENS KONINKLIJKE BIBLIOTHEEK, DEN HAAG

Wolzak, G.G.

Partial discharges and the electrical aging of XLPE cable insulation / by G.G. Wolzak, A.M.F.J. van de Laar and E.F. Steennis. - Eindhoven: University of Technology. - Fig., tab. - (Eindhoven University of Technology research reports / Department of Electrical Engineering, ISSN 0167-9708; 86-E-160)

Met lit. opg., reg.

ISBN 90-6144-160-9

SISO 663.6 UDC 621.317.333 NUGI 832

Trefw.: elektrisch isolatiemateriaal; metingen.

Abstract

This report describes a search for a possible relationship between partial discharges and electrical aging of XLPE cable insulation.

It is well known that partial discharges can deteriorate polymeric insulating materials. Recently several theories on the relationship between partial discharges and aging have been published.

In order to explore this relationship by experiments a method for the detection and localization of small partial discharges (less than 1 pC) in high voltage cables has been developed.

A number of test cables has been aged during six months at a stress of 15 kV/mm rms at the conductor; three cables were held at room temperature and three cables were heated to 90°C conductor temperature.

The following measurements were carried out: partial discharge measurements, $\tan \delta$ measurements, breakdown voltage measurements and measurements on physical and chemical properties.

The results show no significant aging and therefore no correlation between aging and partial discharge activity could be established.

Wolzak, G.G., A.M.F.J. van de Laar and E.F. Steennis

PARTIAL DISCHARGES AND THE ELECTRICAL AGING OF XLPE CABLE INSULATION.

Department of Electrical Engineering, Eindhoven University of Technology, 1986.

EUT Report 86-E-160

Addresses of the authors

Dr.ir. G.G. Wolzak
High-Voltage Laboratory
Department of Electrical Engineering
Eindhoven University of Technology
P.O. Box 513
5600 MB Eindhoven
The Netherlands

Ir. A.M.F.J. van de Laar
Research and Development Department
NKF Kabel B.V.
P.O. Box 26
2600 MC Delft
The Netherlands

Ir. E.F. Steennis
Electrical Research Department
N.V. KEMA
P.O. Box 9035
6800 ET Arnhem
The Netherlands

CONTENTS	PAGE
Abstract	III
1. Introduction	1
1.1 Scope of the work	1
2. A method for detection and localization of partial discharges in high voltage cables.	2
2.1 State of the art	2
2.2 Principle of the detection method	3
2.3 Measuring system	6
2.4 Results	7
2.5 Conclusion	8
3. Accelerated aging and measurements	9
3.1 Introduction	9
3.2 Test program	9
3.2.1 Type of cable	9
3.2.2 Test conditions, test parameters	9
3.2.3 Test set-up	11
3.2.4 Test procedures	12
3.3 Results	12
3.3.1 Electrical characteristics	12
3.3.2 Physical characteristics	14
3.3.3 Chemical characteristics	15
3.3.4 Breakdown voltage distribution	15
4. Conclusions, further outlook	16
Acknowledgements	17
References	18

1. Introduction

Cross-linked polyethylene (XLPE) insulated power cable has a number of advantages with respect to oil-filled paper cable. However while the long-term reliability of oil-filled cable has been proven by a long period of favourable experience, the long-term behaviour of the XLPE insulated cable is still somewhat uncertain.

In this report we discuss the aging of XLPE insulated cable under the influence of electrical and thermal stress under dry conditions.

The electrical aging and breakdown of polymeric insulation have been investigated for more than 30 years. A fact often reported is that partial discharges are responsible for the initiation of electrical breakdown. The correlation between electrical aging and partial discharges is however not fully understood.

For polymeric insulated cable the quality of the extruded dielectric has been greatly improved over the years, resulting in a reduced number of voids and contaminants in the insulation, thus reducing the number and magnitude of the partial discharges. As a consequence of this one could imagine a dielectric (e.g. a cable), free of partial discharges in which no aging would occur.

An interesting question is whether the aging process could start with very small partial discharges, which would escape detection by classical equipment. One would like to have a detection method, suitable for use on full scale cable lengths.

The hypothesis that very small partial discharges play a role is also found in the literature [Er 84, Ra 84, Ly 81, Ok 77].

1.1 Scope of the work

The scope of the work reported here is to search for a relationship between partial discharges and aging of XLPE insulated power cables. To investigate this relationship, first a method was developed for the detection and localization of small partial discharges in medium lengths of power cable. The development of this method is reported in Chapter 2. Next an attempt was made to cause aging of a number of cables under the influence of electrical and thermal stress, during a six month period. During this period the physical and chemical aging processes in the dielectric of the cable were monitored in order to correlate the changes in chemical and physical characteristics with the appearance of partial discharges. The results of the measurements are reported in Chapter 3.

2. A method for detection and localization of partial discharges in high voltage cables.

2.1 State of the art.

The detection of partial discharges in high-voltage cables has received considerable interest during the last two decades. A number of detection methods has been developed, but only those methods that allow localization will be treated here. The measuring techniques for localization can be divided in two groups: 1. scanning methods
2. travelling wave detection methods.

The common aspect of all scanning methods is the movement of detector and cable with respect to each other. The detection can take place by means of electrical contacts [Kr 64] or an acoustic transducer [An 82].

Generally, these methods are applied to unfinished cables and are therefore restricted to factory tests. The development of the travelling wave detection methods has shown considerable progress since the initial work, performed by Kreuger [Kr 64] and Tempelaar [Te 60]. The principle of the travelling wave detection is given in Figure 2.1. A partial discharge in the cable insulation generates travelling waves which propagate in two directions along the cable.

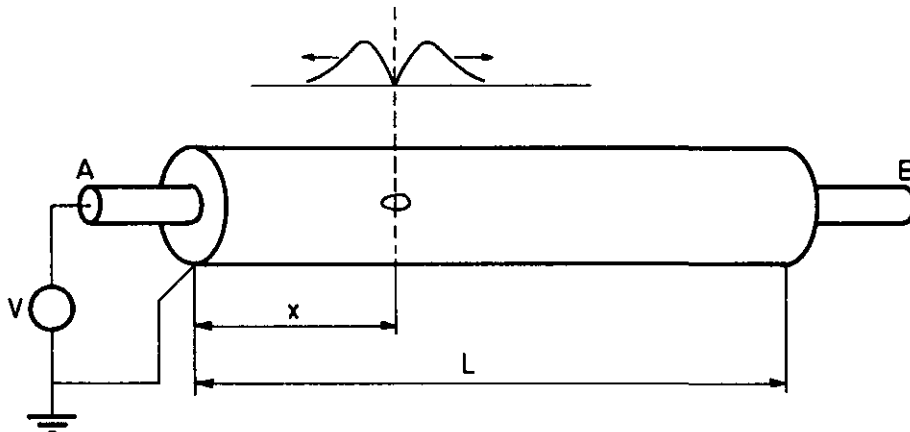

Figure 2.1 Travelling waves generated by a partial discharges in a cable.

The travelling waves can be detected at the cable ends A and/or B. As the waves propagate both on the central conductor and the outer sheath, detection is possible by means of a coupling capacitor connected to the conductor or by an interruption of the outer sheath.

Detection with a coupling capacitor is described in numerous papers [Le 79], [Be 82], [Wi 85]. These methods can be employed for cable lengths in excess of 20 m; the bandwidth of the detection system is in the order of 50 MHz (for longer cables even 10 or 5 MHz). The smallest detectable partial discharge is about 1 pC. Reeves [Re 81] has described an accurate localization method for cables shorter than 20 m. This method employs two coupling capacitors (one at each end) and a dual beam oscilloscope. The bandwidth of the detection system is better than 100 MHz. However, the smallest detectable discharge is 10 pC.

It is interesting at this point to mention two rather peculiar detection methods. Weeks [We 82] describes a specially developed correlation method and Anderson [An 82] investigated the possibilities of time domain reflectometry (TDR). Both methods have not been used extensively up to date.

For the detection and localization of very small partial discharges during the early stage of cable aging, a detection method should be used which meets the following demands:

1. The method must be able to detect partial discharges smaller than 0.1 pC, independent of cable length.
2. An accurate localization of the discharge site must be possible; the aimed inaccuracy is 0.1 m on a cable length of 20 m or less.
3. It must be possible to perform waveform analysis of the detected partial discharge pulses: the waveform of the pulse might change during the aging process of the insulation.
4. The method must allow partial discharge detection on hv and ehv cables.

It is obvious from the foregoing that none of the existing detection methods is able to meet all these demands.

Therefore a new detection method has been developed, based on the principle of ultra wide band detection of the signals over a sheath interruption.

2.2 Principle of the detection method

The required detection sensitivity can be obtained with an ultra wide band (UWB) detection method. Boggs and Stone [Bo 82] have shown that this method is superior to other methods in a number of aspects. The UWB method employs a detection system with a bandwidth as high as possible; the bandwidth can reach up to 1 GHz for Gas Insulated Switchgear.

It has been shown however, that high frequency signals are attenuated while propagating over a power cable. This effect, mainly due to the semiconductive layers (see [St 81], [St 82] and [Wo 83]) limits the usable bandwidth of a detection system to about 200 MHz. A bandwidth of 200 MHz makes it impossible to use external coupling capacitors (as described in sec. 2.1) at the input end of the detection system. This leaves two other options [St 81] [Wo 83]:

- coaxial coupling capacitors, as used in GIS, are impractical for high voltage cable,
- a measuring resistor across an interruption of the outer sheath of the cable.

The latter method has been chosen for this detection method. A picture of the incident, reflected and transmitted travelling waves - generated by the partial discharge - at a sheath interruption is given in Figure 2.2. Important for detection is the relationship between the voltage across the measuring impedance (resistor) Z_m and the original wave amplitude e :

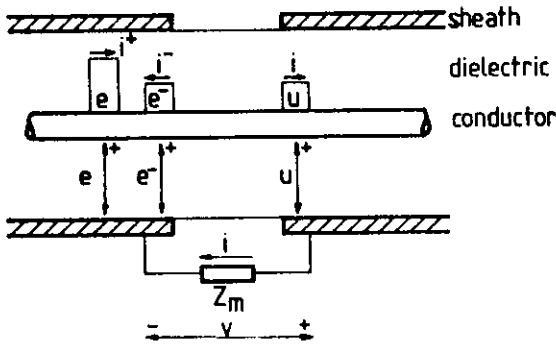

Figure 2.2 Signals at a sheath interruption

$$V = 2e \frac{Z_m}{Z_m + 2 Z_0}$$

The relationship between the apparent charge, q , of the partial discharge and the voltage e is given by:

$$q = - \frac{2}{Z_0} \int_0^{T_0} e dt$$

where T_0 is the duration of the discharge pulse and Z_0 is the characteristic impedance of the cable. If we include the 'ground impedance' Z_g , the wave impedance of the cable sheath with respect to the nearby ground plane, then the expression for V becomes: (see Fig. 2.3)

$$V = 2e \frac{Z_m}{Z_m + 2Z_0 (1 + Z_m/Z_g)}$$

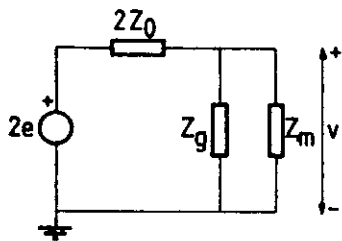

Figure 2.3 Equivalent circuit of sheath interruption.

The measuring impedance Z_m can be formed by a discrete resistor, the resistance of the semiconducting layer and the input impedance of the measuring system.

With two sheath interruptions in a cable, one at each end, the following detection circuits are possible:

- straight detection at one interruption can be used for analysis of the pd pulse shape. For localization one of the two following circuits has to be used.
- detection with two interruptions in parallel, see Figure 2.4a. The equivalent circuit is given in Figure 2.4b.
- balanced detection, see Figure 2.4c. The measuring cable with characteristic impedance Z_m is connected between a and b. A balun (balanced-unbalanced transformer) has to be used to match the differential voltage $V_a - V_b$ to the asymmetric measuring cable and oscilloscope amplifier.

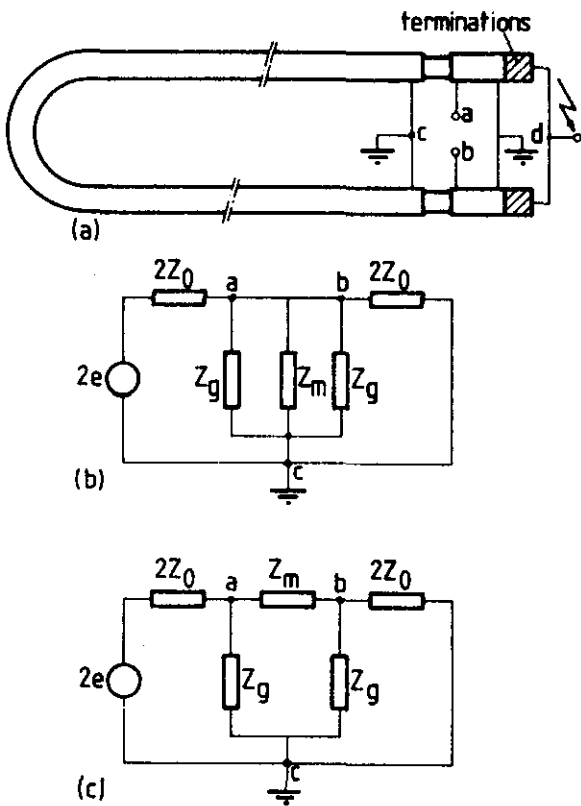

Figure 2.4. Possible measuring circuits:

- (a) cable and sheath interruptions
- (b) unbalanced detection, equivalent circuit
- (c) balanced detection, equivalent circuit.

The voltage sources in (b) and (c) represent one of the two incident wave fronts which may arrive at different moments.

The balanced circuit can be used for the suppression of external interference. However, this advantage is only fully exploited when the remaining cable lengths beyond the interruptions are equal and the high voltage connection (point d. in Figure 2.4.a) is located halfway between the two terminations; only then the transit times of the interfering signals to the interruptions are equal so that they do not show up in $V_a - V_b$.

Localization of a discharge site in the cable between the interruptions is possible by the measurement of the time difference of the pulses, arriving at the interruptions. In two cases this procedure can give some difficulties:

- a pd located exactly in the middle of the cable does not register in the balanced detection set-up, because the two signals arrive at the interruptions simultaneously. The best solution to this problem is to measure with two signals and a dual beam oscilloscope or with the balanced set-up.
- a discharge site in the immediate vicinity of a sheath interruption leads to more complicated signals because reflections from the terminations arrive quickly. In the interpretation one should note that the polarity of the measured pulses depends on the direction in which the wave propagates.

The length of the cable between the interruptions can easily be determined by the injection of a simulated discharge pulse at one interruption which is then measured at both interruptions. The reflected signals from the terminations should not interfere with the direct signals. This can be achieved when the sheath interruptions are at a sufficiently large distance from the terminations. A length of 2 to 3 meters cable is adequate.

2.3 Measuring system

The measuring system consists of the sheath interruptions, the balun, the measuring cable, the preamplifier, and the oscilloscope, see Figure 2.5.

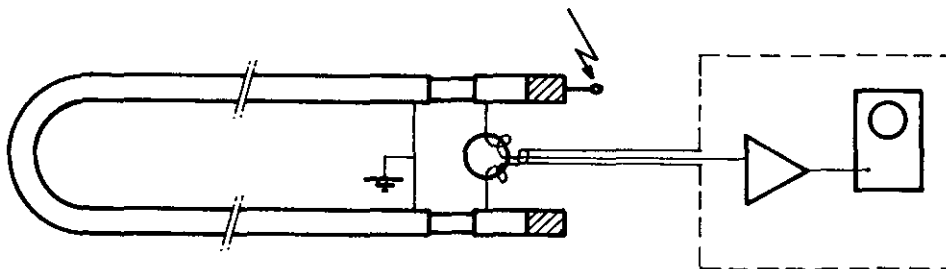

Figure 2.5. Schematic diagram of the measuring system.

The sheath interruption was constructed by removing the outer PVC jacket and the stranded copper wires over a length of about 11 cm. A layer of insulating paper tape is wrapped over the semiconducting layer and the copper wires are reinstalled, leaving an opening of about 1 cm, see Figure 2.6.

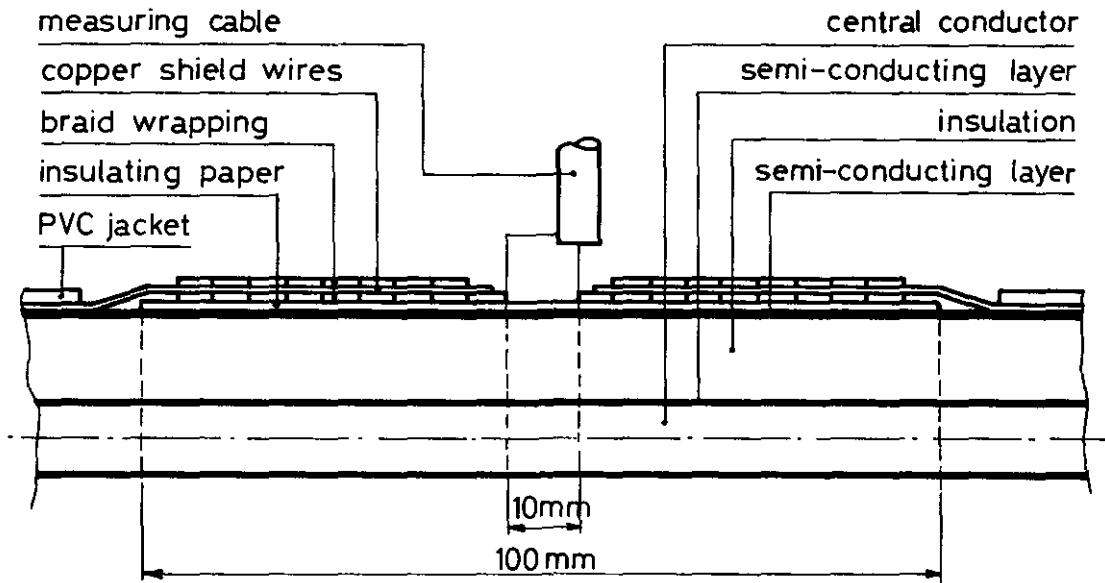

Figure 2.6. Sheath interruption.

In this way the resistance of the sheath interruption is more than 200Ω , while the perturbation of the coaxial geometry is kept to a minimum.

Different types of baluns were used, all with a small ferrite core and 7 to 13 turns of wire, constructed according to Ruthroff [Ru 59]. The bandwidth of all baluns was over 400 MHz. The measuring cable, an RG 214 / U coaxial cable was laid in a copper pipe to eliminate external interference.

For the amplification of small partial discharge signals, two types of preamplifiers were used. Both were Avantek preamps, with 28 dB gain; the 402 type with a bandwidth of 2 MHz - 550 MHz, the 462 model with a bandwidth of 200 Hz - 550 MHz.

The signals were recorded with a Tektronix 7844, 400 MHz oscilloscope and camera. The oscilloscope with the pre-amplifier was located in a small shielded room.

All tests were carried out in a shielded high-voltage hall which provided 80 dB damping of external interference.

2.4 Results

The method has been first tested on two test lengths of XLPE cable and later on the six lengths of XLPE cable of our aging test (see Chapter 3). However, those cables showed very little partial discharge activity. During the pretests and the aging tests, 12 partial discharge have been measured. The magnitude of the discharges varied from 0.3 pC till 10 pC. In all cases the discharges did not occur in the unperturbed cable. The sensitivity of the method depends on the length of the pd pulse. The theoretical sensitivity for this type of cable has been calculated [Wo 83]; a graph is shown in Figure 2.7. A number of measured pulses has also been marked in this Figure.

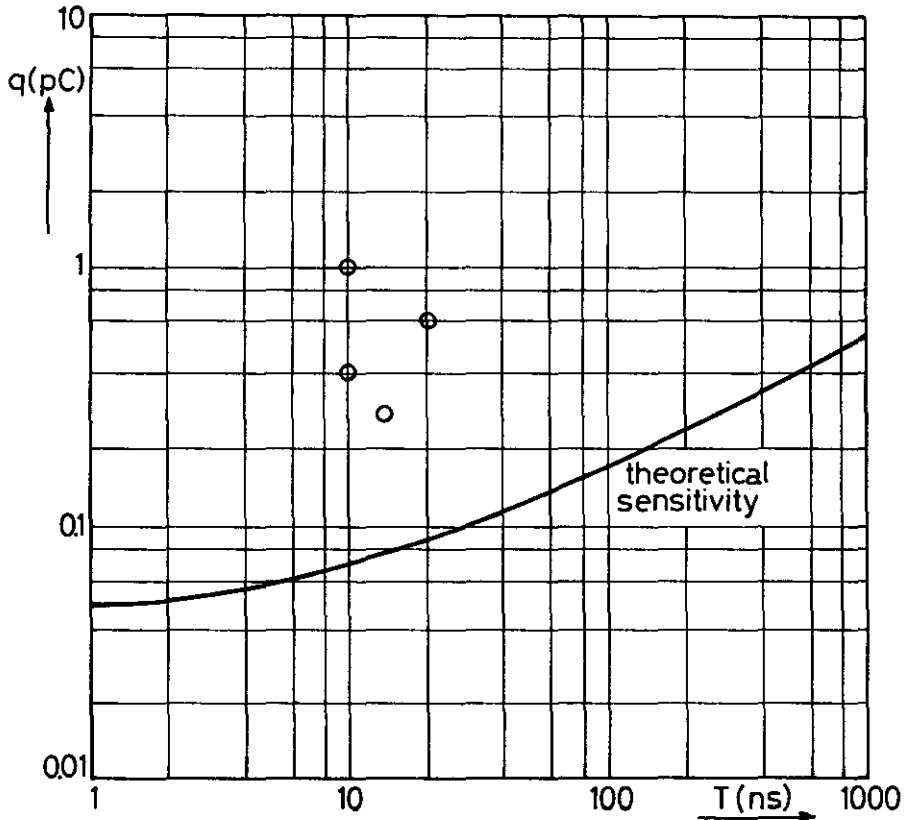

Fig. 2.7 Theoretical sensitivity and observed discharges (small circles).

Only little experience has been gained with the localization of partial discharge sites. In the 10 cases of discharges in the terminations, the localization was relatively easy.

In one case of an internal partial discharge localization was possible with an inaccuracy of 1% of the cable length, 30 cm. The other case of an internal partial discharge was a discharge in between a sheath interruption and the termination; on this short length (5 m) localization was possible within 20 cm.

2.5 Conclusion

A method for detection and localization of partial discharges in medium length of high voltage cables (about 30 m) has been developed. The sensitivity of the method is limited by the useful bandwidth, which is determined by the attenuation of the pd pulses as they propagate along the high-voltage cable.

In cables without semi-conducting layers (such as RG 214/U) much smaller partial discharges (down to 0.04 pC) have been observed [St 81].

A prerequisite for the measurements is a sufficient attenuation of interference to have thermal noise as the limiting factor for the measurements. A shielded high voltage laboratory is a necessary condition for this type of measurements.

3. Accelerated aging and measurements

3.1 Introduction

To establish the correlation between partial discharges and aging of the cable insulation, it was decided to conduct an aging test. Before and after the aging period, the breakdown strength of the cable was to be determined by tests with a stepwise increasing voltage. By comparison of the breakdown strength distributions before and after the aging period, possible aging can be detected and correlated with other phenomena, observed during the tests.

Because uncertainty existed about the aging phenomena it was decided to measure not only partial discharges but also $\tan\delta$ and a number of physical and chemical properties of the cable insulation. The electrical quantities were to be measured on the entire cables, while the physical and chemical properties were to be determined from samples, taken at regular intervals during the aging period.

3.2 Test program

3.2.1 Type of cable.

All tests were carried out with cables, manufactured by NKF. The relevant cable data are shown in table I.

Type -----	YMvKrvc 240 mm ² Al 30/50 kV
Year of production -----	1980
Conductor material and construction -----	solid aluminum
Conductor diameter -----	17.3 mm
Thickness inner semiconducting layer -----	1.1 mm (average)
Insulation material; production process---	Cross-linked PE; long-die
Insulation thickness -----	11.3 mm (average)
Thickness outer semiconducting layer -----	1.2 mm (average)
Earth screen -----	72 Cu wires, 0.8 mm diameter Cu foil 25 x 0.1 mm
Outer jacket -----	5.3 mm PVC

Table I. Data for the cables tested.

The design nominal voltage of the cable is 30 kV (phase to ground); at the nominal voltage the design electrical stress at the conductor is 4.1 kV/mm rms.

3.2.2 Test conditions, test parameters.

The tests were conducted on 6 lengths of cable of the above specified type, each length about 30 m. Three cables (referred hereafter as cables 11, 12 and 13) were kept at room temperature. The other three cables (21, 22 and 23) were heated to a conductor temperature of 90°C by resistive heating.

Each set of three cables was on a separate drum. To accelerate the electrical aging, the test stress was chosen to be 15 kV/mm rms at the conductor. This meant a test voltage of 110 kV (3.67 times the nominal voltage). Because a number of characteristic properties cannot be measured continuously, it was decided to perform all measurements at regular intervals. The period between the measurements was chosen to be two months. During these periods of two months the voltage was to be applied continuously and three cables (21, 22 23) were kept at elevated temperature.

All measurements had to be performed with the cables at room temperature. The electric breakdown strength of the cable has been determined before the tests (on other lengths of cable).

The following properties were measured every two months:

- electrical : partial discharges by means of the wide band method
partial discharges by means of the narrow band method
loss tangent ($\tan \delta$)
- physical : the melting point
Young's modulus ($\log E$)
the mechanical loss tangent
the alpha peak, the temperature at which a maximum mechanical loss tangent is observed
the degree of crystallization
the thermal stability
the modulus of shearing ($\log G$)
- chemical : carbonyl content
cumylalcohol content
acetophenon content

The wide band partial discharge measurements were performed with the method, described in Chapter 2. The narrow band partial discharge measurements were performed with a Robinson (ERA-3) detector with input unit nr. 3.

The measurement of the electric loss tangent ($\tan \delta$) was carried out with a Schering bridge (H & B) with a lock-in amplifier (EG & G 128) as null indicator. The standard capacitor (H & B) was 99.98 pF.

All measurements of physical and chemical properties were carried out at the KEMA laboratories. A detailed description of the results and the methods used can be found in [Ge 84] and the references quoted therein. A brief summary of the measuring methods is given here. The methods were chosen to give an optimal characterization of the material.

The melting point of the insulation is determined by the DSC (differential scanning calorimetry) method.

Young's modulus and the mechanical loss tangent can be determined from the DMTA-curve. The mechanical loss tangent, determined as a function of temperature always has a peak between 40°C and 70°C, the so-called alpha peak.

The degree of crystallization can be determined from the results of density measurements. An indication for the thermal stability of the insulation can be obtained from the results of the TG (thermal-gravimetric) measurements. The modulus of shearing (log G) has been measured with a DMTA (differential thermo mechanical analysis) method. The chemical analysis has been limited to infra-red spectroscopy (for the determination of the carbonyl content) and gaschromatography (for the cumylalcohol and acetophenon content).

3.2.3 Test set-up

As mentioned before 6 lengths of cable were installed on two drums. The terminations of the cables consisted of a stress-cone, an elongated shaft and a surrounding plastic bag, filled with SF₆ gas to prevent external flashover.

The high voltage was supplied by an SF₆ insulated transformer 500 V/250 kV. The high voltage transformer was connected to the mains through a regulating transformer. The high voltage was measured with a precision capacitive divider and registered with a recorder, via a precision ad-dc converter. The inaccuracy of the measuring system was less than 0.5%.

The stability of the mains proved to be sufficient, no further voltage regulation was necessary. During the aging test the voltage remained within 2 kV of the set value. The capacitance of each cable was about 5 nF. This means that the six cables would require a capacitive current of about 1 A. This was considered too much for the transformer, therefore two variable inductance units (Hipotronics) were installed parallel to the cables. A circuit diagram of the high voltage set-up is given in Figure 3.1.

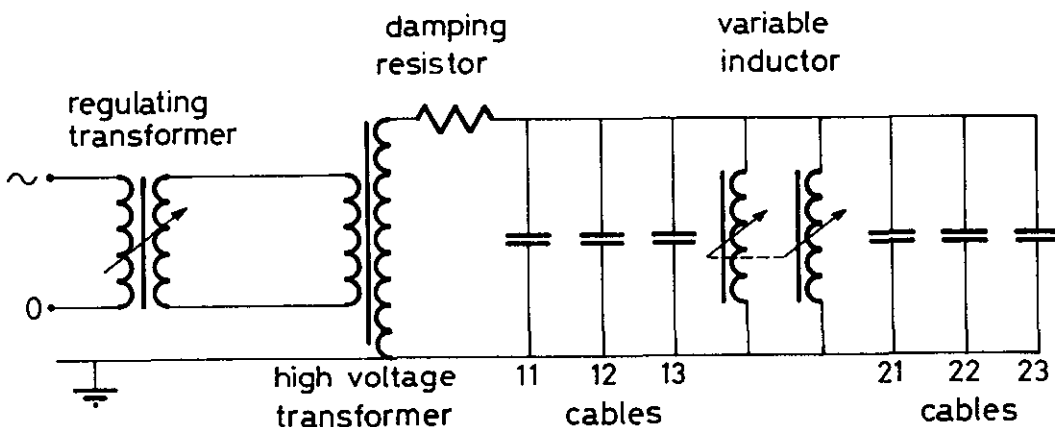

Figure 3.1 Circuit diagram of the hv test set-up.

Three cables were heated to a conductor temperature of 90°C. Temperature measurements were performed on 5 spots on the cables (2 on cable 21, 2 on cable 22, 1 on cable 23) with PT 100 elements and a temperature recorder. The size of the PT 100 elements (2 mm diameter, 20 mm long) made direct temperature measurements at the conductor (of a dummy cable) unpractical. Therefore the sheath temperatures were registered and the conductor temperatures calculated, according to IEC 287. The parts of the cables lying on the drum or close to it were all at nearly the same temperature (within 4°C).

The samples for the measurements of the physical and chemical properties were all taken from parts of the cables close to the drums.

3.2.4 Test procedures

The aging period was divided into a number of measuring periods and three periods of continuous voltage application (accelerated aging periods).

Table II gives a summary of these periods.

period number	type of period	remarks
1	measuring	initial measurements
2	aging	2 months
3	measuring	
4	aging	1 month, breakdown
5	measuring	
6	aging	1 month
7	measuring	
8	aging	2 month
9	measuring	

Table II. Summary of the life test.

Period 4 was terminated unexpectedly by a breakdown in cable 22. To investigate all possible factors which might have influenced this breakdown, an extra measuring period (period nr. 5) was added. After periods nr. 2, 4, 6 and 8 samples were taken from different cables for investigation of physical and chemical properties.

After the final measuring period (nr. 9) the cables were subjected to a stepwise increase voltage test to determine the breakdown voltage distribution. These tests were carried out during 1984.

3.3 Results

3.3.1 Electrical characteristics.

Figure 3.2 summarizes the results of all loss-tangent measurements. The initial value and the value after 6 months of aging are given for each cable. The loss-tangent was measured as a function of voltage in steps of 12 kV but did hardly depend on the measuring voltage. Data is for this reason only given for one voltage level (60 kV).

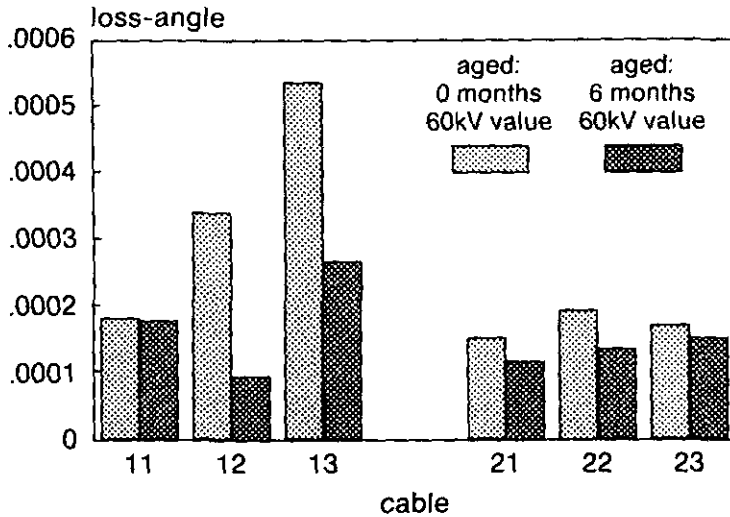

Fig. 3.2 Summary of the loss-tangent measurements for all cables.

The $\tan \delta$ of cables 21, 22 and 23 is very constant and nearly the same (2×10^{-4}) for all cables. This might be attributed to the heating of the cables (the cables were also heated before the life test to verify the proper temperature distribution) which causes the evaporation of a number of chemical additives to the insulation which are known to increase the loss tangent.

The results of the p.d. measurements will be summarized by the measuring periods rather than by cable number. Only internal discharges in the cables exceeding the noise level will be discussed.

Period 1

No discharges

Period 3

Cable 22 showed a discharge between the sheath interruptions, see Figure 3.3.

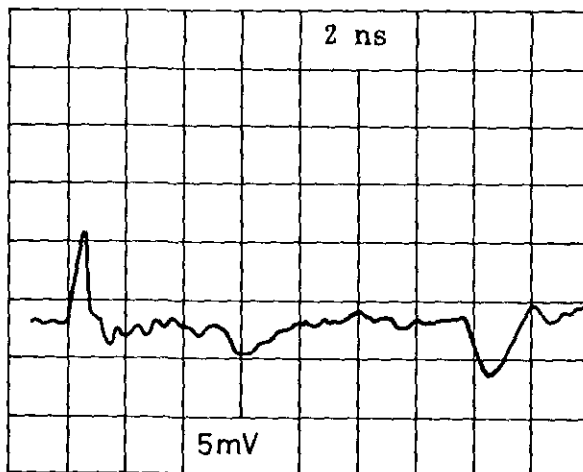

Figure 3.3 Partial discharge in cable 22.

From transit time measurements it became clear that this discharge (0.4 pC, $V_i = 45$ kV) was in or very close to a sheath interruption.

Period 5

No discharges

Period 7

No discharges

Period 9

Cable 13 had a small discharge (0.5 pC, $V_i = 100$ kV) in one of the stress cones.

Cable 21 had a discharge of 3 pC ($V_i = 80$ kV) which resembled an internal discharge, see Fig. 3.4.

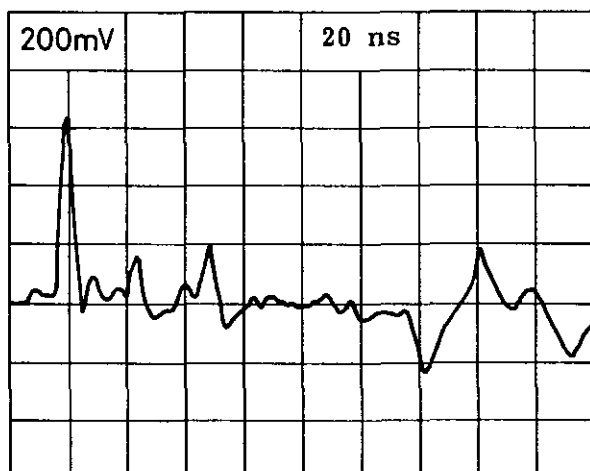

Figure 3.4. Partial discharge in cable 21

However, a very careful examination, for which an extra sheath interruption was made between the termination and the original one showed, that this signal was caused by a discharge in a stress cone.

3.3.2. Physical characteristics

- From the results of the DSC measurements, the melting-points of the insulation can be determined as a function of time. A slight increase of the melting point is expected. Figure 3.5 shows, that the melting point hardly changes.

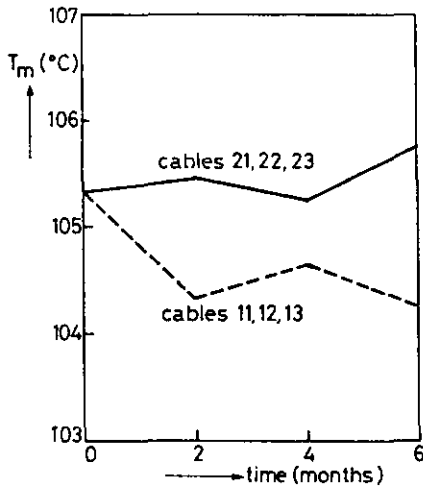

Figure 3.5 Results of the DSC measurements

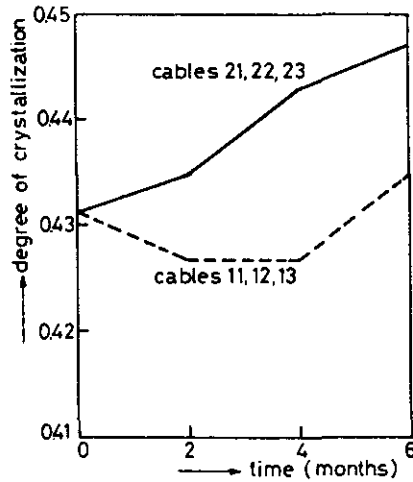

Figure 3.6 Results of the density measurements

- The results of the DMTA measurements show a large and unexplained scattering in Young's modulus.
- Figure 3.6 gives the degree of crystallization as a function of time. The increase of the degree of crystallization of the sample which has been aged at 90°C was expected. However results on other cables are not that clear.
- All other measurements of physical characteristics (mechanical loss tangent, alpha peak, thermal stability and modulus of shearing) do not show significant results.

3.3.3. Chemical characteristics

The measurements of the carbonyl-content show no significant changes as a function of time, except for those samples that were close to the conductor. The measurements on the contents of cumylalcohol and acetophenon are not showing systematic changes as a function of time.

3.3.4. Breakdown voltage distribution

The initial breakdown voltage distribution has been determined with a 20% stepwise increase voltage test. The results are analysed by using a sensored maximum likelihood method to determine the Weibull parameters. The breakdown distribution is shown in Fig. 3.7. After the 6 month life test the remaining cable samples are also subjected to the above mentioned breakdown test. Because the number of samples is limited only termination flashovers occurred. These values are also given in Fig. 3.7. No significant difference between the initial breakdown values and those after aging can be observed.

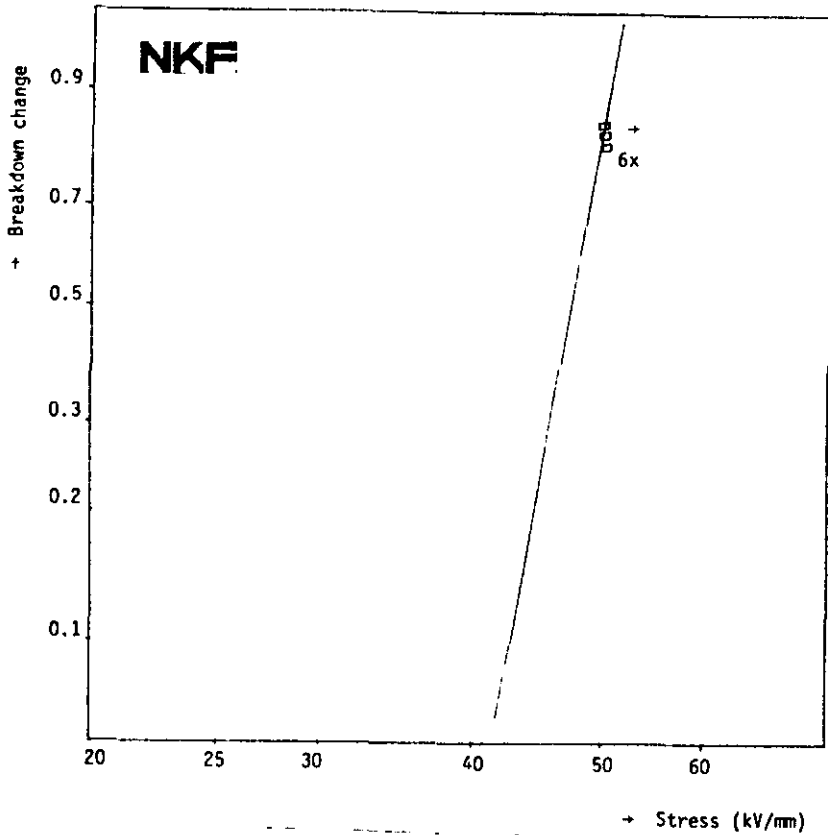

Fig. 3.7 Weibull plot of original distribution. A voltage level at flashover for aged cables.

4. Conclusions, further outlook.

Improvements on a partial discharge measuring method have made it possible to detect and localize small partial discharges in a length of about 30 meter of high-voltage cable. Since a wide-band detection system is used the actual waveform can be observed. This waveform might be useful for diagnostic purposes.

A number of test cables has been aged during six month at a stress of 15 kV/mm rms at the conductor; three cables were held at room temperature and three cables were heated to 90°C conductor temperature.

The following measurements were carried out: partial discharge measurements, $\tan \delta$ measurements, breakdown voltage measurements and measurements on physical and chemical properties.

The results show no significant aging and therefore no correlation between aging and partial discharge activity could be established.

Acknowledgements

The research, described in this report, has been carried out at the High-Voltage Laboratory of the Eindhoven University of Technology under the supervision of Prof.dr.ir. P.C.T. van der Laan. The technical staff of this laboratory is gratefully acknowledged for their valuable technical assistance. The research has been made possible by financial and material support of KEMA Laboratories, Arnhem, Netherlands. The authors appreciate the many fruitful discussions with dr.ir. J.H. Blom, ir. W. Boone, ir. A.W. van Hamel and drs. W.S.M. Geurts of these laboratories. The cables and other equipment have been supplied by NKF Kabel, Delft, Netherlands. Ir. M. Bal of this company contributed by many valuable comments.

References

- [An 82] Anderson, W.E. and J.D. Ramboz, A.R. Ondrejka
THE DETECTION OF INCIPIENT FAULTS IN TRANSMISSION CABLES
USING TIME DOMAIN REFLECTOMETRY TECHNIQUES: Technical
challenges.
IEEE Trans. Power Appar. & Syst., Vol. PAS-101(1982),
p. 1928-1934.
- [Ba 82] Bahder, G. and T. Garrity, M. Sosnowski, R. Eaton, C. Katz
PHYSICAL MODEL OF ELECTRIC AGING AND BREAKDOWN OF EXTRUDED
POLYMERIC INSULATED POWER CABLES.
IEEE Trans. Power Appar. & Syst., Vol. PAS-101(1982),
p. 1379-1390.
- [Ba 83] Bahder, G. and M. Sosnowski, C. Katz, R. Eaton, K. Klein
ELECTRICAL BREAKDOWN CHARACTERISTICS AND TESTING OF HIGH
VOLTAGE XLPE AND EPR INSULATED CABLES.
IEEE Trans. Power Appar. & Syst., Vol. PAS-102(1983),
p. 2173-2185.
- [Be 82] Beyer, M. and W. Kamm, H. Borsi, K. Feser
A NEW METHOD FOR DETECTION AND LOCATION OF DISTRIBUTED
PARTIAL DISCHARGES (CABLE FAULTS) IN HIGH VOLTAGE CABLES
UNDER EXTERNAL INTERFERENCE.
IEEE Trans. Power Appar. & Syst., Vol. PAS-101(1982),
p. 3431-3438.
- [Bo 82] Boggs, S.A. and G.C. Stone
FUNDAMENTAL LIMITATIONS IN THE MEASUREMENT OF CORONA AND
PARTIAL DISCHARGE.
IEEE Trans. Electr. Insul., Vol. EI-17(1982), p. 143-150.
- [Bo 84] Boone, W. and E.F. Steennis, P.A.C. Bentvelsen, A.M.F.J.
van de Laar
DEVELOPMENT AND TRIAL OF EHV XLPE CABLES IN THE NETHERLANDS.
In: Proc. 30th Session Int. Conf. on Large High Voltage
Electric Systems (CIGRÉ), Paris, 29 Aug.-6 Sept. 1984.
Paris: CIGRÉ, 1984. Paper 21-02.
- [Ch 83] Cheo, P.K. and R. Luther, J.W. Porter
DETECTION OF VOIDS AND CONTAMINANTS IN POLYETHYLENE INSULATED
CABLE UTILIZING A FIR LASER BEAM.
IEEE Trans. Power Appar. & Syst., Vol. PAS-102(1983),
p. 521-526.
- [Er 84] Eriksson, A.J. and H. Kröniger
ACCELERATED LIFE PERFORMANCE STUDIES ON A SAMPLE 132 kV
XLPE INDUSTRIAL CABLE INSTALLATION.
In: Proc. 30th Session Int. Conf. on Large High Voltage
Electric Systems (CIGRÉ), Paris, 29 Aug.-6 Sept. 1984.
Paris: CIGRÉ, 1984. Paper 15-05.
- [Ge 84] Geurts, W.S.M.
VEROUDERING VAN KABELS MET ISOLATIE VAN VERNET POLYETHYLEEN:
Chemische begeleiding van onderzoek partiële ontladingen.
[Aging of cables with XLPE insulation: Chemical aspects].
Arnhem: KEMA, 1984.
Internal report III 9610/84.

- [Kr 64] Kreuger, F.H.
DISCHARGE DETECTION IN HIGH VOLTAGE EQUIPMENT.
London: Heywood, 1964.
- [Le 79] Lemke, E.
A NEW METHOD FOR PD MEASUREMENT ON POLYETHYLENE INSULATED
POWER CABLES.
In: Proc. 3rd Int. Symp. on High Voltage Engineering, Milan,
28-31 Aug. 1979.
Milano: Associazione Elettrotecnica ed Elettronica Italiana,
1979. Paper 43.13.
- [Ly 81] Lyle, R. and J.W. Kirkland
AN ACCELERATED LIFE TEST FOR EVALUATING POWER CABLE INSULATION.
IEEE Trans. Power Appar. & Syst., Vol. PAS-100(1981),
p. 3764-3774.
- [Ok 77] Okamoto, H. and M. Kanazashi, T. Tanaka
DETERIORATION OF INSULATING MATERIALS BY INTERNAL DISCHARGE.
IEEE Trans. Power Appar. & Syst., Vol. PAS-96(1977),
p. 166-177.
- [Ra 84] Rageb, M.H.S.A. and A.J. Pearmain
AN APPROACH TO THE PREDICITON OF THE LIFETIME OF ELECTRICAL
INSULATIONS.
IEEE Trans. Electr. Insul., Vol. EI-19(1984), p. 107-113.
- [Re 81] Reeves, J.H.
THE LOCATION OF PARTIAL DISCHARGE SITES IN H.V. SWITCHGEAR
AND SHORT CABLES BY A TRAVELLING WAVE METHOD.
In: Proc. 6th Int. Conf. on Electricity Distribution (CIRED),
Brighton, 1-5 June 1981.
London: IEE, 1981. IEE Conf. Publ., No. 197. P. 246-250.
- [Ru 59] Ruthroff, C.L.
SOME BROAD-BAND TRANSFORMERS.
Proc. IRE, Vol. 47(1959), p. 1337-1342.
- [St 81] Steennis, E.F.
METINGEN VAN PARTIËLE ONTLADINGEN IN HOOGSPANNINGSKABELS.
[Measurements of partial discharges in high-voltage cables].
M.Sc. Thesis. High Voltage Laboratory, Department of
Electrical Engineering, Eindhoven University of Technology,
1981.
Internal report EH.81.A.65.
- [St 82] Stone, G.C. and S.A. Boggs
PROPAGATION OF PARTIAL DISCHARGE PULSES IN SHIELDED POWER
CABLE.
In: Annual Report 51st Conf. on Electrical Insulation and
Dielectric Phenomena, Amherst, Mass., 17-21 Oct. 1982.
Piscataway, N.J.: IEEE Service Center, 1982. P. 275-280.
- [Te 60] Tempelaar, H.G.
HET AANTONEN VAN ONTLADINGEN IN HET ISOLATIEMATERIAAL VAN
HOOGSPANNINGSKABELS. [The detection of discharges in the
insulation of high-voltage cables].
Electrotechniek, Vol. 38(1960), p. 403-410.

- [We 82] Weeks, W.L. and J.P. Steiner
INSTRUMENTATION FOR THE DETECTION AND LOCATION OF INCIPIENT
FAULTS ON POWER CABLES.
IEEE Trans. Power Appar. & Syst., Vol. PAS-101(1982),
p. 2328-2335.
- [Wi 85] Wieringa, L.
LOCATION OF SMALL DISCHARGES IN PLASTIC INSULATED HIGH
VOLTAGE CABLES.
IEEE Trans. Power Appar. & Syst., Vol. PAS-104(1985), p. 2-8.
- [Wo 83] Wolzak, G.G.
THE DEVELOPMENT OF HIGH-VOLTAGE MEASURING TECHNIQUES.
Ph.D. Thesis. Eindhoven University of Technology, 1983.

- (138) Nicola, V.F.
A SINGLE SERVER QUEUE WITH MIXED TYPES OF INTERRUPTIONS: Application to the modelling of checkpointing and recovery in a transactional system.
EUT Report 83-E-138. 1983. ISBN 90-6144-138-2
- (139) Arts, J.G.A. and W.F.H. Merck
TWO-DIMENSIONAL MHD BOUNDARY LAYERS IN ARGON-CESIUM PLASMAS.
EUT Report 83-E-139. 1983. ISBN 90-6144-139-0
- (140) Willems, F.M.J.
COMPUTATION OF THE WYNER-ZIV RATE-DISTORTION FUNCTION.
EUT Report 83-E-140. 1983. ISBN 90-6144-140-4
- (141) Heuvel, W.M.C. van den and J.E. Daalder, M.J.M. Boone, L.A.H. Wilmes
INTERRUPTION OF A DRY-TYPE TRANSFORMER IN NO-LOAD BY A VACUUM CIRCUIT-BREAKER.
EUT Report 83-E-141. 1983. ISBN 90-6144-141-2
- (142) Fronczak, J.
DATA COMMUNICATIONS IN THE MOBILE RADIO CHANNEL.
EUT Report 83-E-142. 1983. ISBN 90-6144-142-0
- (143) Stevens, M.P.J. en M.P.M. van Loon
EEN MULTIFUNCTIONELE I/O-BOUWSTEEN.
EUT Report 84-E-143. 1984. ISBN 90-6144-143-9
- (144) Dijk, J. and A.P. Verlijdsdonk, J.C. Arnbak
DIGITAL TRANSMISSION EXPERIMENTS WITH THE ORBITAL TEST SATELLITE.
EUT Report 84-E-144. 1984. ISBN 90-6144-144-7
- (145) Weert, M.J.M. van
MINIMALISATIE VAN PROGRAMMABLE LOGIC ARRAYS.
EUT Report 84-E-145. 1984. ISBN 90-6144-145-5
- (146) Jochems, J.C. en P.M.C.M. van den Eijnden
TOESTAND-TOEWIJZING IN SEQUENTIËLE CIRCUITS.
EUT Report 85-E-146. 1985. ISBN 90-6144-146-3
- (147) Rozendaal, L.T. en M.P.J. Stevens, P.M.C.M. van den Eijnden
DE REALISATIE VAN EEN MULTIFUNCTIONELE I/O-CONTROLLER MET BEHULP VAN EEN GATE-ARRAY.
EUT Report 85-E-147. 1985. ISBN 90-6144-147-1
- (148) Eijnden, P.M.C.M. van den
A COURSE ON FIELD PROGRAMMABLE LOGIC.
EUT Report 85-E-148. 1985. ISBN 90-6144-148-x
- (149) Beeckman, P.A.
MILLIMETER-WAVE ANTENNA MEASUREMENTS WITH THE HP8510 NETWORK ANALYZER.
EUT Report 85-E-149. 1985. ISBN 90-6144-149-8
- (150) Meer, A.C.P. van
EXAMENRESULTATEN IN CONTEXT MBA.
EUT Report 85-E-150. 1985. ISBN 90-6144-150-1
- (151) Ramakrishnan, S. and W.M.C. van den Heuvel
SHORT-CIRCUIT CURRENT INTERRUPTION IN A LOW-VOLTAGE FUSE WITH ABLATING WALLS.
EUT Report 85-E-151. 1985. ISBN 90-6144-151-x
- (152) Stefanov, B. and L. Zarkova, A. Veefkind
DEVIATION FROM LOCAL THERMODYNAMIC EQUILIBRIUM IN A CESIUM-SEEDED ARGON PLASMA.
EUT Report 85-E-152. 1985. ISBN 90-6144-152-8
- (153) Hof, P.M.J. Van den and P.H.M. Janssen
SOME ASYMPTOTIC PROPERTIES OF MULTIVARIABLE MODELS IDENTIFIED BY EQUATION ERROR TECHNIQUES.
EUT Report 85-E-153. 1985. ISBN 90-6144-153-6
- (154) Geerlings, J.H.T.
LIMIT CYCLES IN DIGITAL FILTERS: A bibliography 1975-1984.
EUT Report 85-E-154. 1985. ISBN 90-6144-154-4
- (155) Groot, J.F.G. de
THE INFLUENCE OF A HIGH-INDEX MICRO-LENS IN A LASER-TAPER COUPLING.
EUT Report 85-E-155. 1985. ISBN 90-6144-155-2
- (156) Amelsfort, A.M.J. van and Th. Scharfen
A THEORETICAL STUDY OF THE ELECTROMAGNETIC FIELD IN A LIMB, EXCITED BY ARTIFICIAL SOURCES.
EUT Report 86-E-156. 1986. ISBN 90-6144-156-0
- (157) Lodder, A. and M.T. van Stiphout, J.T.J. van Eijndhoven
ESCHER: Eindhoven SCHEmatic Editor reference manual.
EUT Report 86-E-157. 1986. ISBN 90-6144-157-9
- (158) Arnbak, J.C.
DEVELOPMENT OF TRANSMISSION FACILITIES FOR ELECTRONIC MEDIA IN THE NETHERLANDS.
EUT Report 86-E-158. 1986. ISBN 90-6144-158-7