

# Experimental modal analysis of an automobile tire under static load

**Citation for published version (APA):**

Pieters, R. S. (2007). *Experimental modal analysis of an automobile tire under static load*. (DCT rapporten; Vol. 2007.112). Technische Universiteit Eindhoven.

**Document status and date:**

Published: 01/01/2007

**Document Version:**

Publisher's PDF, also known as Version of Record (includes final page, issue and volume numbers)

**Please check the document version of this publication:**

- A submitted manuscript is the version of the article upon submission and before peer-review. There can be important differences between the submitted version and the official published version of record. People interested in the research are advised to contact the author for the final version of the publication, or visit the DOI to the publisher's website.
- The final author version and the galley proof are versions of the publication after peer review.
- The final published version features the final layout of the paper including the volume, issue and page numbers.

[Link to publication](#)

**General rights**

Copyright and moral rights for the publications made accessible in the public portal are retained by the authors and/or other copyright owners and it is a condition of accessing publications that users recognise and abide by the legal requirements associated with these rights.

- Users may download and print one copy of any publication from the public portal for the purpose of private study or research.
- You may not further distribute the material or use it for any profit-making activity or commercial gain
- You may freely distribute the URL identifying the publication in the public portal.

If the publication is distributed under the terms of Article 25fa of the Dutch Copyright Act, indicated by the "Taverne" license above, please follow below link for the End User Agreement:

[www.tue.nl/taverne](http://www.tue.nl/taverne)

**Take down policy**

If you believe that this document breaches copyright please contact us at:

[openaccess@tue.nl](mailto:openaccess@tue.nl)

providing details and we will investigate your claim.

# **Experimental Modal Analysis of an Automobile Tire under Static Load**

R.S. Pieters

Report No. DCT 2007.112

Traineeship Report

Coach: Dr. Ir. I. Lopez Arteaga  
Supervisor: Prof. Dr. H. Nijmeijer

Eindhoven University of Technology  
Department of Mechanical Engineering  
Dynamics and Control Group

Eindhoven, June, 2007



## **Abstract**

In this report, the dynamic behavior of a standard automobile tire under a static load of 4000 Newton is investigated. This research was carried out for a traineeship at Eindhoven University of Technology and is a follow up of former studies in the research on tire modal analysis. To perform this experimental modal analysis, the tire is mounted on the flat plank tire tester to achieve the required support and operating conditions. A shaker excites the tire at the sidewall and the responses caused by these vibrations are measured with an accelerometer. Together with a force transducer and a dynamic signal analyzer frequency response functions are computed in order to obtain the modal parameters of the loaded tire. A ring-shaped outline and the cross-section of the tire are measured. From these measurements, the in-plane mode shapes are visualized. For the outline 60 measurement points are taken around the whole circumference of the tire. For the cross-section 21 measurement points are needed and only half of these are measured due to the symmetry of the cross-section.

These measurements are performed under two conditions; one with no load applied to the tire, the other with a load of 4000 Newton. These two situations are compared with each other and conclusions are drawn from the effect of an applied load to an automobile tire.

The boundary condition, the fixed, loaded tire to the road, doubles the number of resonance peaks. This is best visualized by changing the position of excitation slightly and comparing the acquired mode shapes with each other. The first six in-plane mode shapes, numbered 1 to 6, are visualized and their natural frequencies are determined. The same is done for the doubled mode shapes and are numbered 1,5 to 6,5. The result therefore is that an applied static load to a tire doubles the number of resonance frequencies and increases its stiffness and thus its natural frequencies.

## Table of Contents

<b>Introduction</b> .....	1
1.1 Tire vibration responses .....	1
1.2 Goals and Outline .....	2
<b>Experimental Modal Analysis</b> .....	3
2.1 Frequency response functions.....	3
2.2 Mode shapes.....	3
2.3 Measurement equipment.....	4
2.4 Excitation .....	4
2.5 FRF validation .....	5
<b>Results</b> .....	6
3.1 Performed measurements.....	6
3.2 Effect of static load .....	8
3.3 FRF and Mode shapes.....	8
<b>Conclusions and Recommendations</b> .....	12
<b>Bibliography</b> .....	13
<b>Appendix A</b> Measurement points on the circumference.....	14
<b>Appendix B</b> Measurement points on the tread.....	15
<b>Appendix C</b> Estimated in-plane mode shapes of the circumference with load (4000N)..	16
<b>Appendix D</b> Estimated in-plane mode shapes of the circumference without load .....	19
<b>Appendix E</b> Estimated in-plane mode shapes of the tread .....	21
<b>Appendix F</b> Frequency response functions .....	23

## Chapter 1

### Introduction

An experimental modal analysis is performed to obtain the modal parameters of a tire under static load. To investigate the effects of this static load, another analysis was performed on the tire with no load. Frequency response functions and modal parameters can be used to compare with an analysis obtained by a finite element package, 'Abaqus'. By validating the numerical analysis with the experimental one, great benefits can be made in predicting the tire vibration responses, with regards to tire design and performance.

#### 1.1 Tire vibration responses

Since the tire is the only component that connects the vehicle to the road, it becomes more and more important to understand its behavior and response to different inputs. Roughly, a tire can be subdivided in three categories when regarding the vibration response:

Tire with whole vehicle:	0,5 – 3 Hz.
Suspension and steering:	10 – 30 Hz.
Tire itself:	30 – 300 Hz.

Typically, below 100 Hz, rigid body modes can be identified. A rigid body mode refers to those vibrations of the tire where the tire tread-band moves as a rigid mass on a spring. Above 100 Hz, in-plane modes are present, which show deformations of the tire tread-band. See figure 1.1 and figure 1.2 for a presentation of these rigid body and in-plane modes. More information about rigid and in-plane modes can be found in reference [5]. In this research only in-plane modes are taken into account. Only one ring is measured in the circumference of the tire and because these measurements are in radial direction, the lateral, steer and torsion rigid body mode (see figure 1.1) cannot be identified.

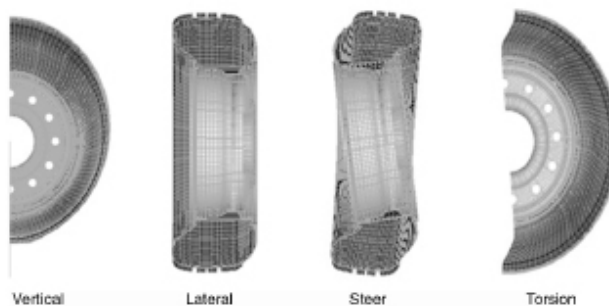
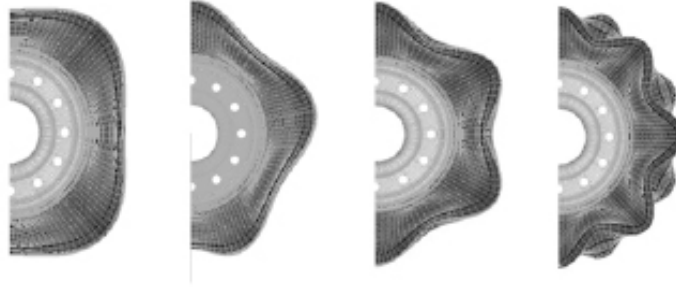

Figure 1.1 rigid body modes of a tire (<100 Hz.)

Due to the excitation direction being horizontal, the vertical rigid body mode (see figure 1.1) is not excited and is therefore also not identified.



**Figure 1.2 in-plane modes of a tire (>100 Hz.)**

Since a static load is applied, the dynamic behavior of the tire has changed. The load causes the tire to be more stiff, fixes the tire on the road and eliminates its circular symmetry. The changes caused by these conditions are discussed in this report.

## **1.2 Goals and Outline**

The goal of this research is to determine the modal parameters and mode shapes of a pneumatic automobile tire under a static load of 4000 Newton. The differences in modal parameters and mode shapes between a loaded and an unloaded tire are also a part of this. This report is divided into the three following subjects. First a brief introduction is made into tire vibration responses in chapter 1. Then experimental modal analysis is further reviewed, with its different aspects, where a complete chapter is devoted to the validation, or the checking, of an FRF measurement. This is to be found in chapter 2.5. In chapter 3, the performed measurements are presented and the results obtained are reviewed and discussed. The effect of a static load is analyzed (chapter 3.2) and the differences in frequency response functions are shown (chapter 3.3). Finally the conclusions and recommendations are discussed in chapter 4.

## ***Chapter 2***

### **Experimental Modal Analysis**

By means of measuring the response of a structure, caused by a hammer or shaker, a frequency response function can be obtained. The input force is measured by a force transducer and the response by an accelerometer. A dynamic signal analyzer then computes the desired output. The measures that have to be taken, in order to obtain such response is treated in this chapter.

There are various different ways of performing a dynamic analysis. Depending on the system, the available equipment and also the required output, choices have to be made in order to acquire the best results. Another important issue is the validation of the obtained results and on which basis a measurement may be assumed as correct. A quick guideline will be presented for getting the best result in the shortest amount of time.

#### **2.1 Frequency response functions**

A thorough explanation of frequency response functions will not be given in this report. This is treated in many previous studies and their reports. See for example reference [2]. The natural frequency gives the position of the peaks, the width of the peak determines the degree of damping and the height of the peak gives the amplitude of vibration. Sharp peaks mean little damping, thus the natural modes do not influence each other. By investigating the frequency response functions from a tire with and without load, dynamic effects that are caused by the applied load, can be identified.

#### **2.2 Mode shapes**

Each mode shape is the result of two waves traveling in opposite direction around the circumference, or cross-section, of the tire and interfering with each other.

Only in-plane modes will in this research be taken into account, thus not all shapes will be visible and some shapes cannot be identified due to a lack of measurement points in the y-direction (tread-side).

For each wavelength at least six points have to be measured in order to get a smooth shape. Therefore, in order to see up to nine or ten wavelengths around the tire circumference, sixty points were measured. Unfortunately, because of the difference in magnitude of the frequency response function at higher frequencies and therefore the difficulty of recognizing peaks at those frequencies, no shapes higher than approximately 300 Hz were visualized. As mentioned before; in this research only in-plane modes are of interest, and thus only these are presented.



### 2.3 Measurement equipment

In order to perform the experiments, the measurement equipment has to be chosen with great care, as it will partly determine the quality of a good measurement. The used equipment will not be treated; these are well specified in reference [2]. The measurement equipment used was: a shaker, a stinger, a dynamic signal analyzer (Siglab), an accelerometer and a force transducer. The stinger was screwed in a big nut, which was glued to the side of the tire.

In order to apply a static load, the tire is positioned on the flat plank, which is located at the Automotive Engineering lab. Here a load varying from 0 to 8000 N can be applied. Also different angles (camber, side slip, steer) can be adjusted. In this experiment only a static load is applied, all other angles are set to zero or to normal operating conditions. An overview of the flat plank is to be seen in figure 1.1

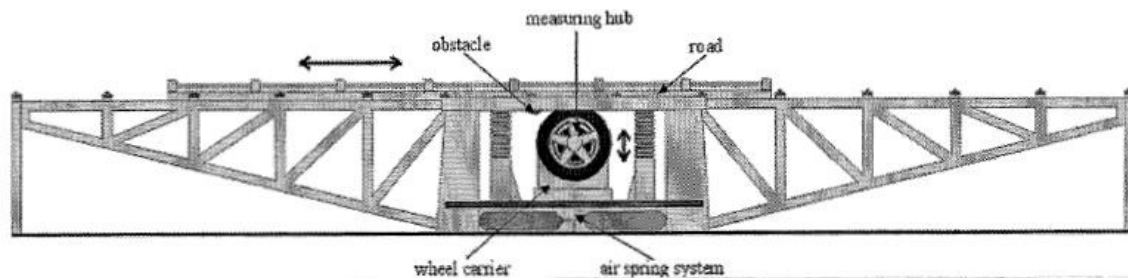

Figure 2.1 flat plank

### 2.4 Excitation

The type of excitation used to estimate frequency response functions depends on several factors. Generally, the excitation signal is chosen in order to minimize noise, non linearities and leakage, while estimating the most accurate frequency response function in the least amount of time. The types of excitation to be used can be classified in a few different categories. They are as follows:

- Steady state (slow swept sine, stepped sine)
- Random (true random)
- Periodic (chirp, pseudo random, periodic random)
- Transient (burst random, impact, impulse)

The advantages and disadvantages of every signal will not be treated in this report, but can be found in reference [1].

The signal used to excite the tire is **random**. The advantage of a random signal is that it removes non linear effects, noise and distortion. Also the measurement time is quiet fast.

However, this signal is not periodic which will cause leakage; therefore a window can be used and many averages have to be taken. In this case, the standard ‘hanning’ window was used, and the frequency response function was computed by averaging 30 measurements.

## **2.5 FRF validation**

Before analyzing the different frequency response functions, it has to be made sure that these are correct and not corrupted with noise or false data. A few methods are mentioned in order to validate such measurements.

### **FRF**

There are a few guidelines for checking whether an FRF is reliable or not. First, the overall shape of an FRF must be correct and as what would be expected. High and low frequency behavior and their asymptotes should coincide with the dynamics of the measured system. An asymptote at very low frequencies should correspond to a stiffness-like characteristic, because the structure is tested in grounded conditions. Deviations from this expected behavior can be caused by a frequency resolution being too coarse, or the fact that the support conditions are not met. On the other hand, at high frequencies, asymptotes should also have stiffness-like characteristics. In this case, the stiffness asymptote should be at the same height as the stiffness of the measured system, which is the case, so support conditions are met.

The sequence of the resonances and anti-resonances in a FRF also show the dynamics and the behavior of a system, which, obviously, should coincide with what would be expected. Also, comparison with sets of frequency response functions can be made. This so-called  $\Delta FRF$  function should be small and not excessively varying or shifting.

For a more thorough explanation in these checks, see reference [1].

### **Coherence function**

The coherence function gives information with regard to which part of the output is caused by the input and which part is due to noise. A lower value of the coherence can occur at an anti-resonance. This is caused by a lack of energy in the auto power spectrum, which is used to calculate the coherence function, resulting in a smaller input-output relation. A typical good coherence function has the value between 0,9 and 1.

## ***Chapter 3***

### **Results**

In this chapter, the experimentally obtained results are discussed. The effects of the changed support and operating conditions are reviewed and furthermore the consequences of a load applied to the tire in combination with the fixed contact patch are treated.

#### **3.1 Performed measurements**

The measured tire is a standard automobile tire with dimensions; 205R15/60. The inflation pressure during the experiments is 1.6 bar (160 KPa). Two different measurements were carried out in order to determine the modal parameters of the tire under static load. Before these measurements were performed, first a new position for the shaker had to be validated. In figure 3.1 is to be seen where the shaker was attached. The reason for this is that little space was available for the shaker to be attached as in former studies. Also because the tire is fixed and loaded at the top side, the circular symmetry is lost. Therefore the shaker couldn't be attached at either side of the tire and had to be positioned at the front, lower side. In order to validate this position for excitation, measurements were carried out with the same tire, which suspended freely and the shaker positioned as mentioned before. This position gave the same results as in previous studies and was therefore validated.

In order to visualize all the mode shapes and resonance frequencies, which appear twice, due to the boundary conditions, two different excitation positions were chosen on the side of the tire. First as mentioned before and to be seen in figure 3.1, second where the tire is rotated slightly (25 degrees) and thus giving the shaker this new position. This can be seen in figure 3.2; the first method positions the shaker at point number 1, the second method positions the shaker at point number 56.

The two main performed measurements are as follows:

- An experimental modal analysis of the tire with no static load.
- An experimental modal analysis of the tire with a static load of 4000 Newton.

Both analyses were carried out for one complete outline of the tire and also for one outline of the tread side of the tire. The complete outline measures 60 points, the tread side 21. An overview of these points can be found in appendix A and B. Also, the Single Input Multiple Output technique (SIMO) is used. This means that the structure is excited at one position and measured at several different positions.

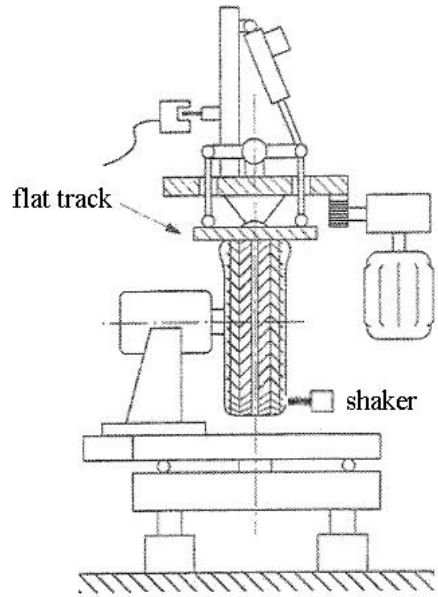

**Figure 3.1 Sideview flat plank with tire and shaker**

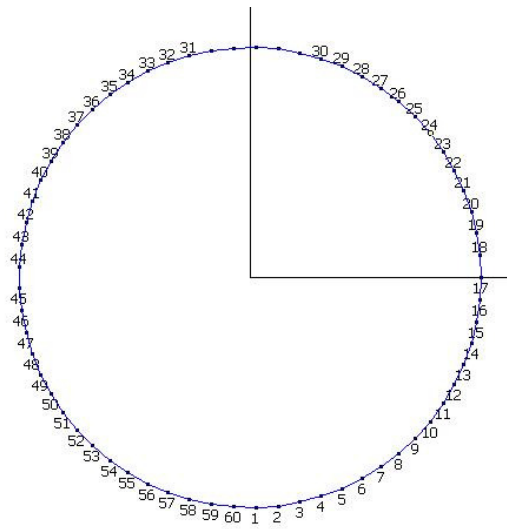

**Figure 3.2 Overview measurement points on circumference.**

### **3.2 Effect of static load**

As mentioned before, first a new position for excitation had to be chosen and validated before the effect of the static load on a tire could be analyzed. This position was taken radial on the tire's sidewall and validated with the frequency response functions performed in a previous study; reference [2]. Hereafter, the tire was mounted on the flat plank tire tester. Under these conditions two modal analyses were carried out, one without a static load, the other one with a static load of 4000 N, as if it was positioned under a car.

From literature we know that each mode is double; for every natural frequency two identical mode shapes exist. The boundary condition has the effect that the identical shapes split into two not identical ones. The resonance peaks also split into two different frequencies with different height which varies considerably. The mode shape subdivides in a symmetric and anti-symmetric shape. Therefore, a new excitation position is used to visualize these doubled mode shapes and the resonance peaks. The frequency response functions can be seen in appendix F. The first analysis with load and the shaker connected at the lower point is referred to as the half mode shapes and resonance frequencies ( $1\frac{1}{2}$  to  $6\frac{1}{2}$ ). The second analysis with load and the shaker connected at point number 56 is referred to as the whole mode shapes and resonance frequencies (1 to 6). Further analysis is discussed in the next chapter (3.3). In figure 3.3, figure 3.4, figure 3.5, figure 3.7 and table 3.1 it can be seen that, due to the load, the resonance frequencies shift upwards in comparison with the no load analysis. Also, in table 3.1, the damping is slightly lower for the loaded tire. This is what might be expected. Normally as a load is applied, it increases stiffness and thus would increase the natural frequency and decrease the damping coefficient.

### **3.3 FRF and Mode shapes**

Compared to the frequency response functions of a tire without load, it can be seen that, overall, the new doubled resonance frequencies shift upwards in frequency. Except the first half mode frequency, which is lower than the first no load frequency. The reason for this is not clear.

When comparing the mode shapes, it can be seen that the shapes without load and the half mode shapes are equal. See appendix C and D for these mode shapes.

In combination with visualizing the mode shapes, all natural frequencies belonging to the first eight in-plane mode shapes, which are sixteen in total, are identified. However, since it becomes increasingly more difficult to visualize a mode shape with higher frequencies, only the first six in-plane mode shapes, and thus twelve in total, are presented. These are to be found in appendix C. It can be seen, in figure 3.6, that due to the support and operating conditions of the tire (a fixed contact patch and an applied static load) mode shapes at higher frequencies tend to miss one or more, so called, leaves in their shape and are therefore harder to identify.

As explained in chapter 3.1 and chapter 3.2, due to support conditions, not all mode shapes can be visualized. By rotating the tire and thus changing the position of excitation,

all mode shapes can be found. In appendix C the changes of these mode shapes can be seen.

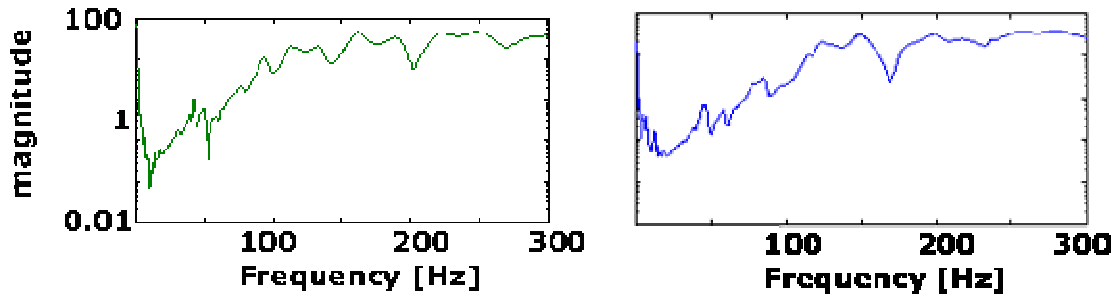

Figure 3.3 FRF unloaded (left) and loaded (right) tire

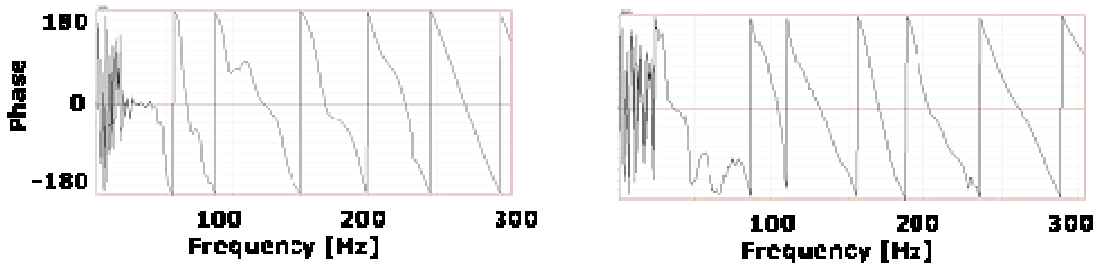

Figure 3.4 Phase of unloaded (left) and loaded (right) tire

In figure 3.3 and 3.4 the frequency response functions and phase plots are shown. In figure 3.5 a more clear view on the frequency shift is shown.

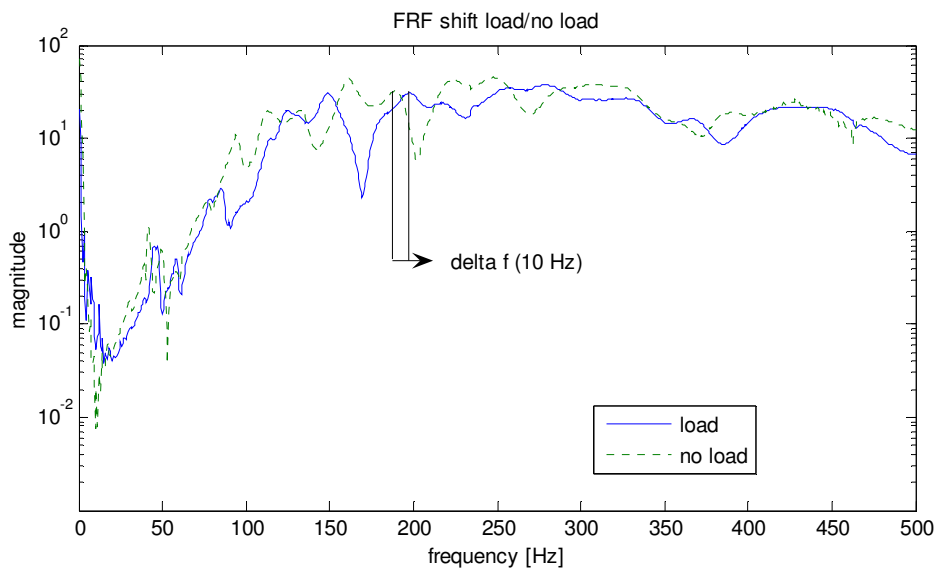
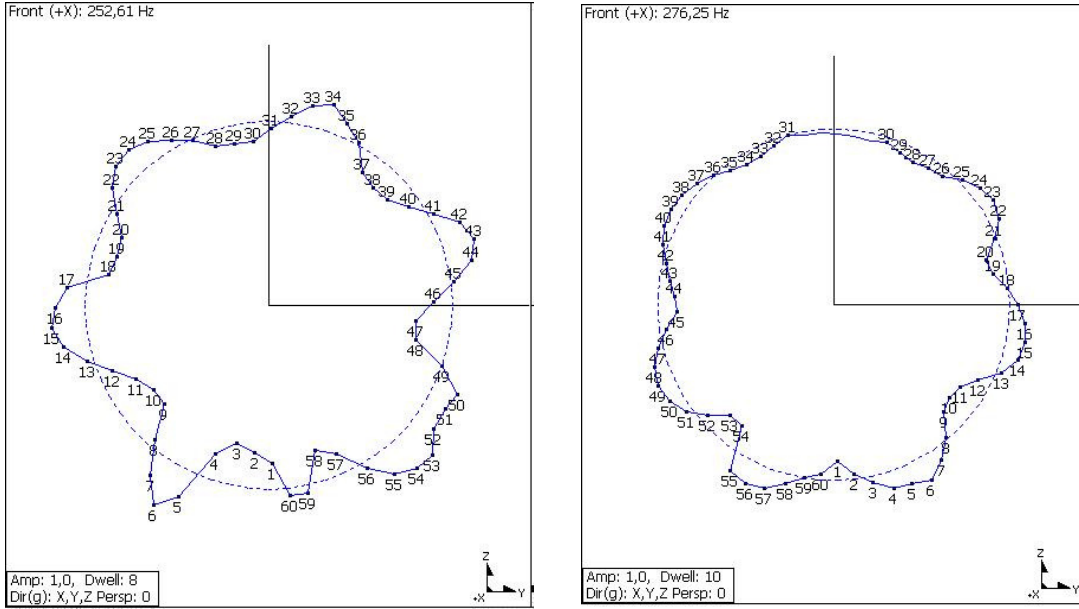
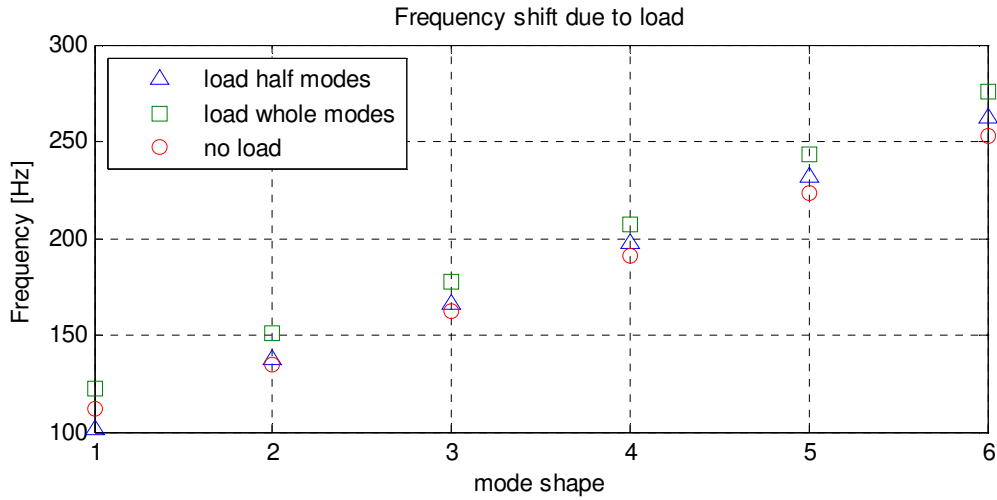

Figure 3.5 Phase of unloaded (left) and loaded (right) tire

Also, the frequency response functions can be viewed in more detail in appendix F.



**Figure 3.6 Mode shape 6 of unloaded (left) and loaded (right) tire. In right figure, at the top, a leaf is 'missing'.**



**Figure 3.7 Frequency shift due to load.**

	no load		4000 N		4000 N	
	freq.	damping (%)	freq.	damping	freq.	damping
mode 1	112 Hz	3,522	101 Hz	3,121	122 Hz	3,345
mode 2	134 Hz	3,245	138 Hz	2,875	151 Hz	2,965
mode 3	161 Hz	3,787	166 Hz	3,433	178 Hz	3,488
mode 4	191 Hz	3,035	198 Hz	2,688	207 Hz	2,712
mode 5	221 Hz	3,856	232 Hz	3,321	243 Hz	3,190
mode 6	250 Hz	3,285	262 Hz	2,843	276 Hz	2,734

**Table 3.1 Modal frequencies for loaded and unloaded tire.**



## Conclusions and Recommendations

An experimental modal analysis was carried out in order to investigate the effects of a static load on a tire. The modal parameters of a loaded (4000 N) tire are computed and the first six in-plane mode shapes are visualized. The fixed contact point of the tire to the road causes the number of resonance frequencies and mode shapes to double. The mode shapes belonging to these 'new', doubled resonance frequencies appear equal to the original and are just slightly rotated; they are clearly subdivided in a symmetric and anti-symmetric shape. The first six natural frequencies corresponding to the first six in-plane mode shapes for a loaded (4000 N) tire are: 122 Hz, 151 Hz, 178 Hz, 207 Hz, 243 Hz and 276 Hz. The six doubled natural frequencies corresponding to the rotated six in-plane mode shapes for a loaded (4000 N) tire are: 101 Hz, 138 Hz, 166 Hz, 198 Hz, 232 Hz and 262 Hz. As compared with a no-load situation and in former studies, it can be seen that, overall, the frequencies shift approximately 10 to 22 Hz higher, or, the tire becomes more stiff with increasing static load.

Another issue is the effect of the contact point of the tire to the road, or in this case the load. This causes the circular symmetry to be lost. The effect of this is that mode shapes with higher frequencies (250 Hz and up) are getting increasingly more difficult to visualize and thus more difficult to identify.

Furthermore, a few recommendations can be made for further studies on experimental modal analysis of an automobile tire. In this research only in-plane modes are presented. In order to visualize the rigid body modes a new research should be carried out with a number of outlines in the circumference. This will however be a very extensive experiment since for only one outline 60 measurement points are needed.

In order to visualize all the different mode shapes it should also be cleared up which excitation position, or more if needed, is the best for an experimental modal analysis on a loaded tire.

Different conditions can be changed to investigate their effect on the modal parameters of a tire. Suggestions are; inflation pressure or static load.

The flat plank tire tester is able to alter a variety of different angles and forces on which a tire can be exposed. Camber, side slip and steer angles can be changed to investigate their effect on the modal parameters.

Furthermore, the effect of the load and the fixed point on a rotating tire could be of interest. For this, the measurement tower in the AES laboratory should be used.

At last, the experimental analysis can be compared with a numerical analysis which is performed with a FEM package. This FEM analysis can accordingly be checked for correctness.

## **Bibliography**

- [1] D.J. Ewins, Modal testing: theory, practice and application, second edition, 2000.
- [2] J.H.A.M. Vervoort, Experimental modal analysis of an automobile tire, Bachelor final project report No, DCT 2007.084
- [3] O. Dönmez, Experimental modal analysis of an automobile tire, Erasmus internship report No, DCT 2007.015.
- [4] R.J.E. Merry, Experimental modal analysis of the H-drive, Report No. DCT 2003.78
- [5] G.D. Shteinhaus, L.T. Charek, The Goodyear Tire Rubber Company, Tire vibrations, 2001.
- [6] P.W.A. Zegelaar, Modal analysis of tire in-plane vibrations, SAE paper 971101, Vehicle research laboratory, Delft University of Technology.

## Appendix A

### Measurement points on the circumference

The complete circumference is divided in 65 points; where in total 60 points are measured. This means, approximately, every 5,5 degrees a measured point. In figure A.2 direction 'R' is the direction of measurement, which is the same for every measurement point.

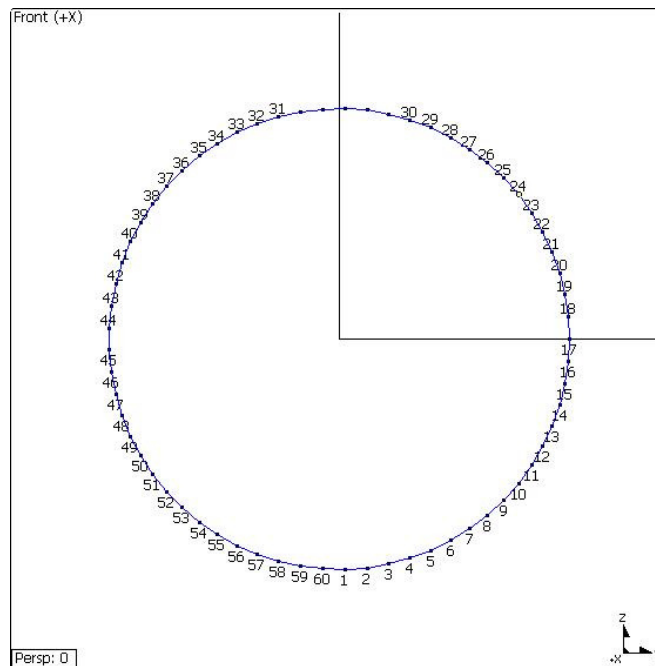

Figure A. 1 measurement points on circumference

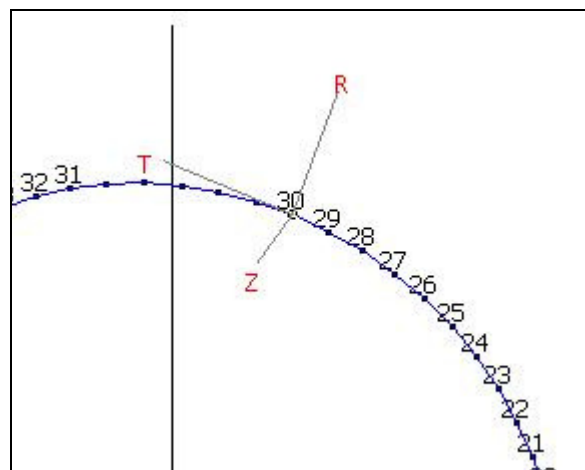

Figure A. 2 Measurement direction; R

## Appendix B

### Measurement points on the tread

The tread side of the tire is divided in 21 points, where 11 are measured. One half of the tire's tread side is mirrored in z-direction.

As mentioned before, the 'R'-direction is the direction of measurement, also the same for every measured point.

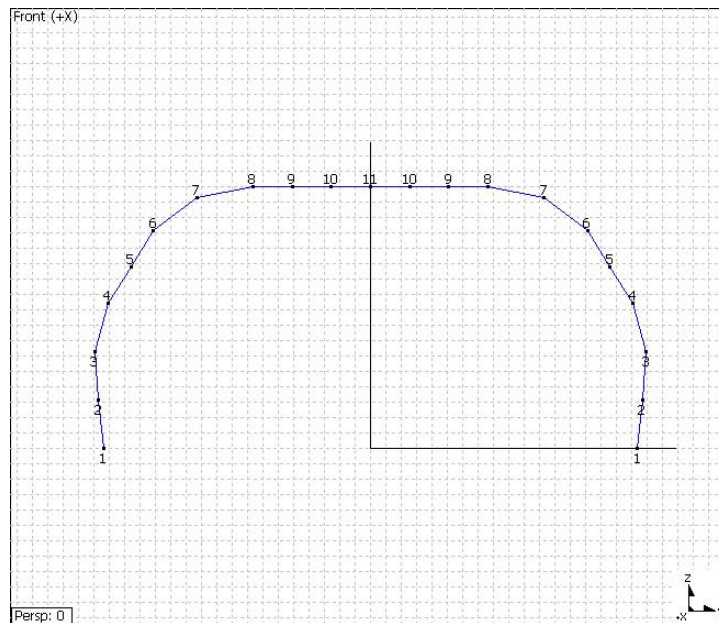

Figure B. 1 measurement points on tread

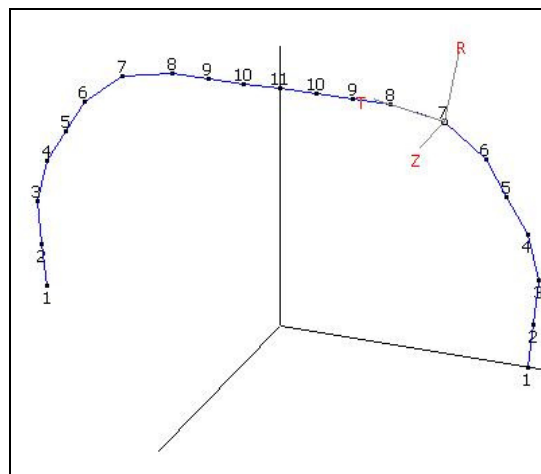

Figure B. 2 measurement direction; R

## Appendix C

### Estimated in-plane mode shapes of the circumference with load (4000N)

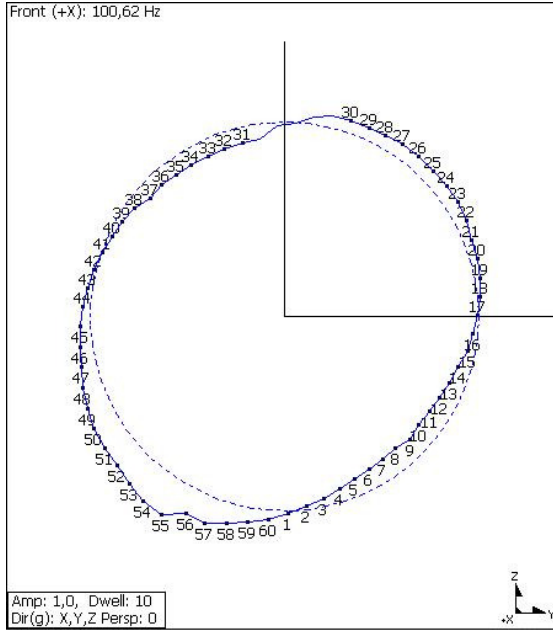

Figure C. 1 mode 1 at 101 Hz.

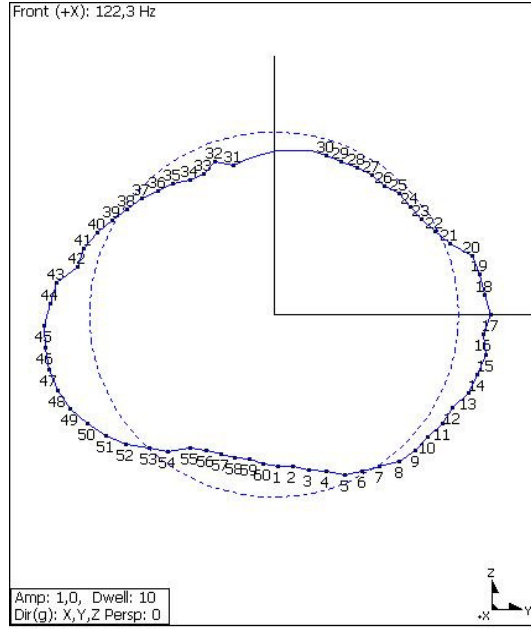

Figure C. 2 mode 1½ at 122 Hz.

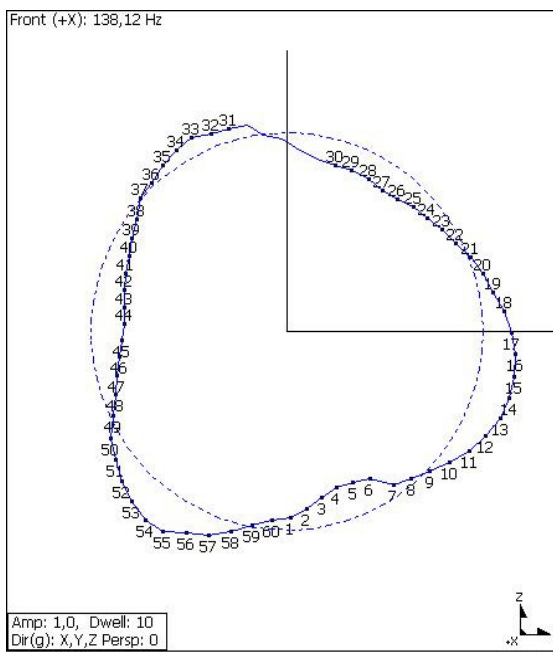

Figure C. 3 mode 2 at 138 Hz.

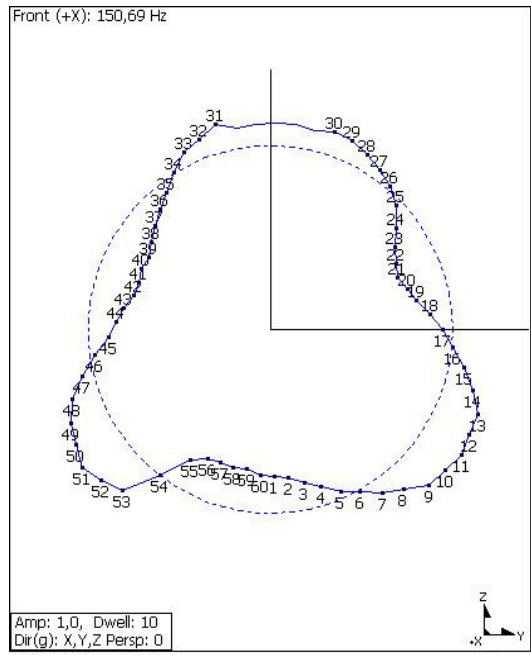
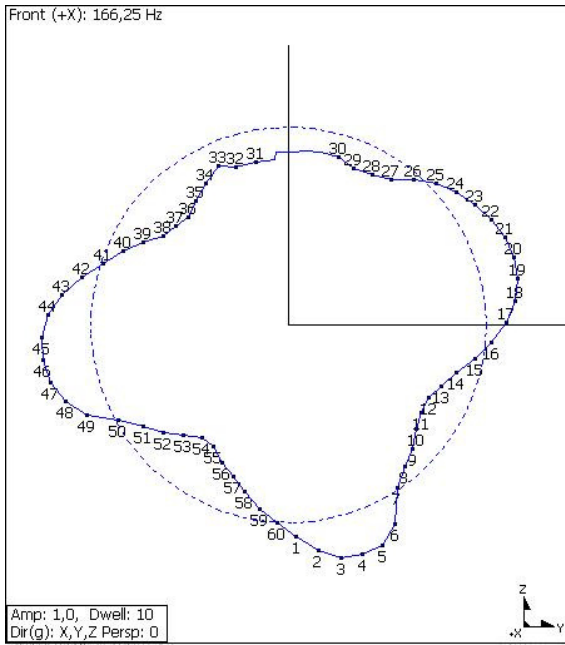
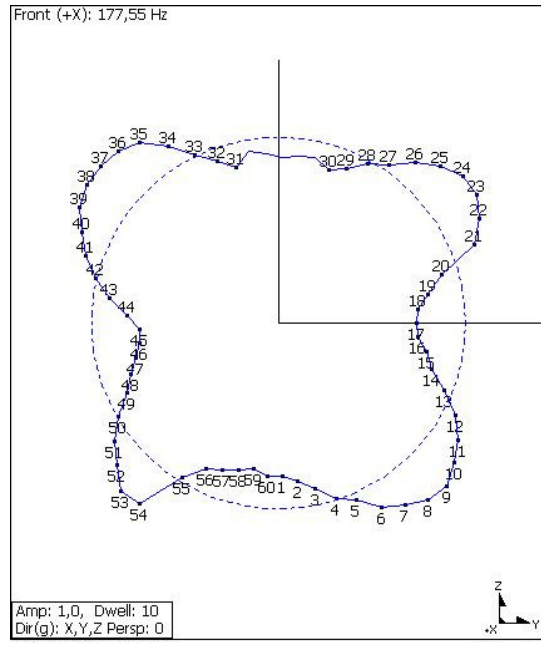

Figure C. 4 mode 2½ at 151 Hz.



**Figure C. 5 mode 3 at 166 Hz.**



**Figure C. 6 mode 3½ at 178 Hz.**

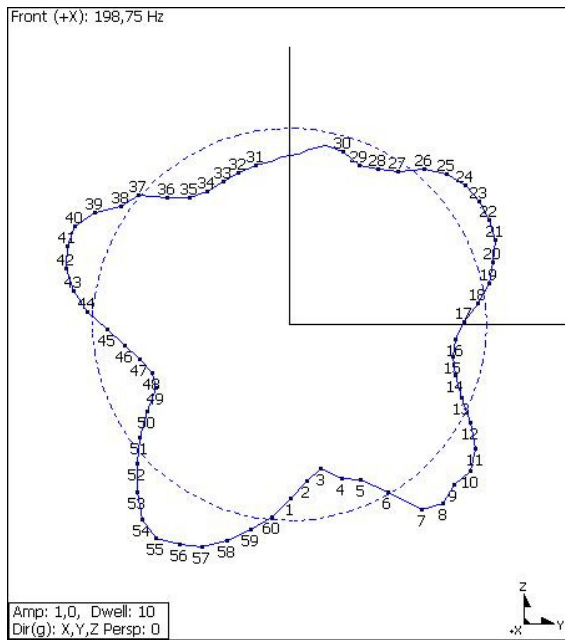

**Figure C. 7 mode 4 at 198 Hz.**

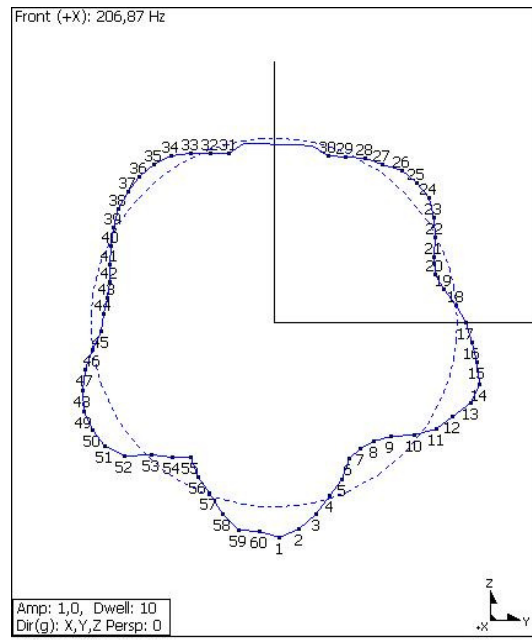

**Figure C. 8 mode 4½ at 207 Hz.**

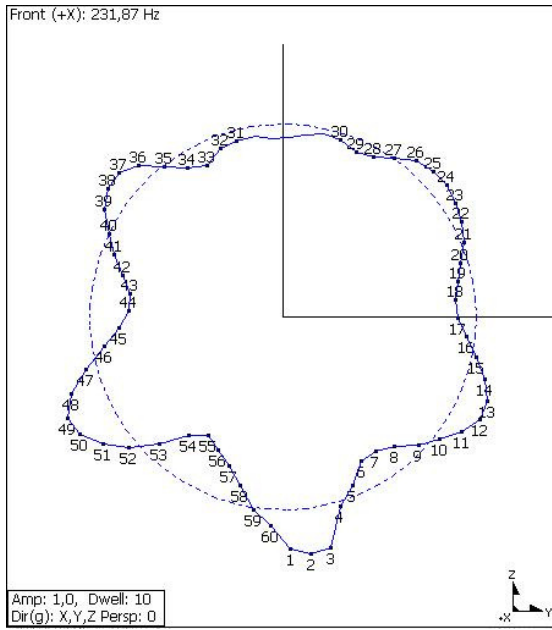

**Figure C. 9 mode 5 at 232 Hz.**

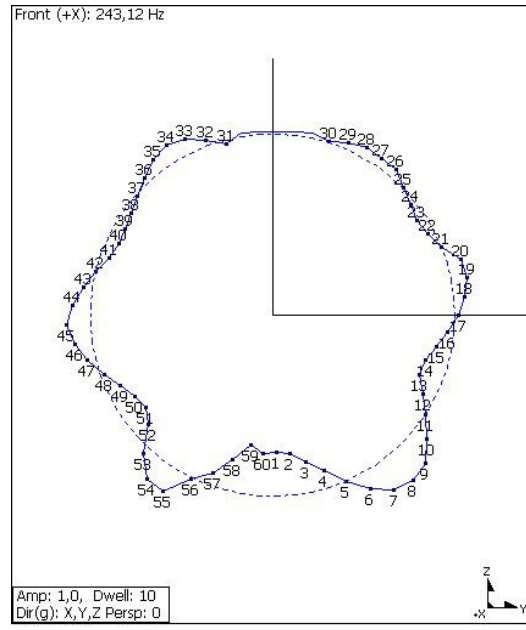

**Figure C. 10 mode 5½ at 243 Hz.**

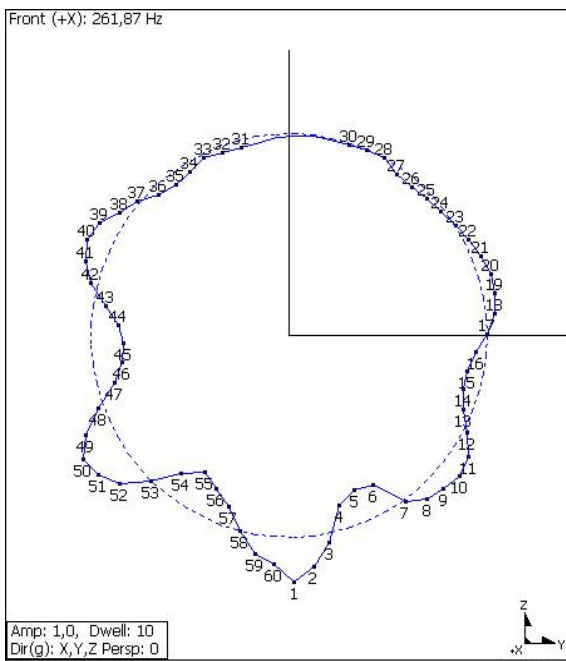

**Figure C. 11 mode 6 at 262 Hz.**

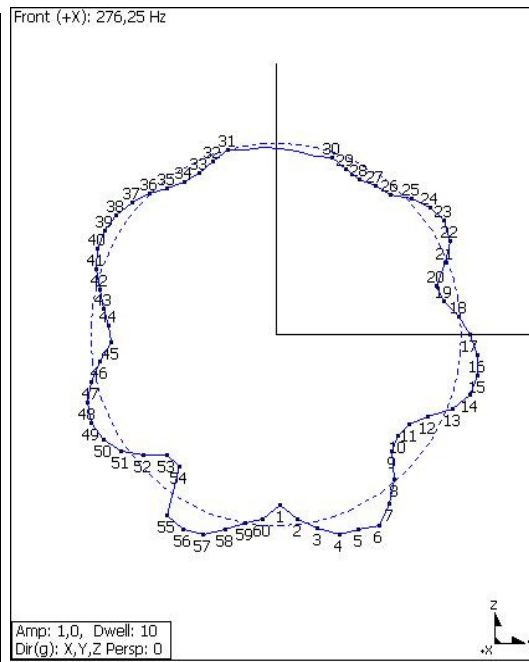

**Figure C. 12 mode 6½ at 276 Hz.**

## Appendix D

### Estimated in-plane mode shapes of the circumference without load

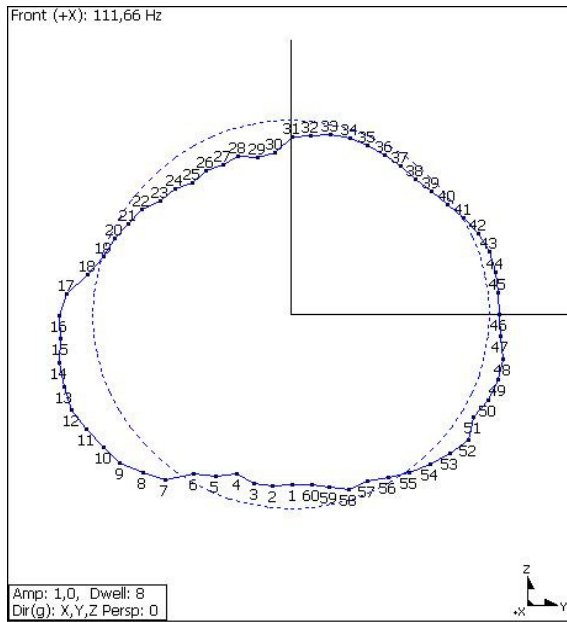

Figure D. 9 mode 1 at 112 Hz.

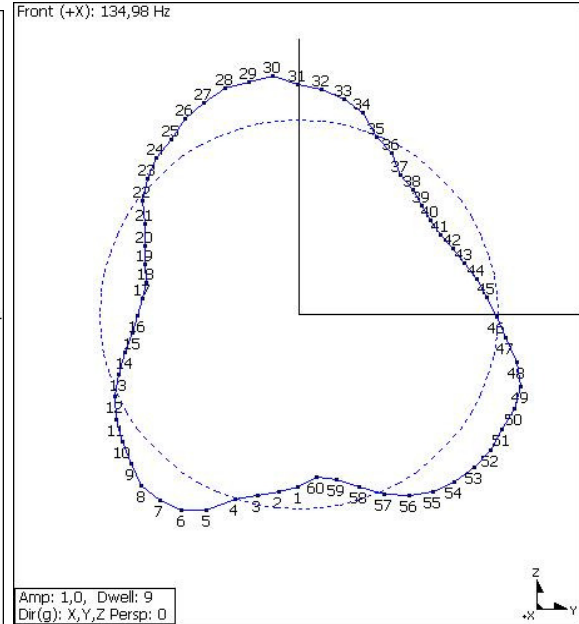

Figure D. 10 mode 2 at 135 Hz.

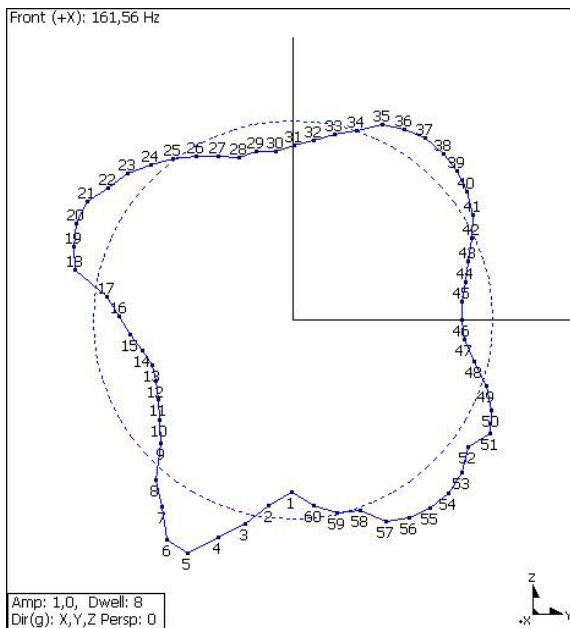

Figure D. 11 mode 3 at 162 Hz.

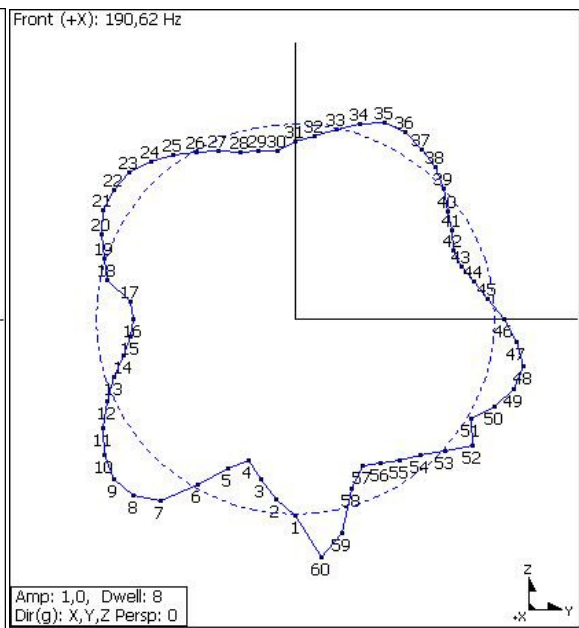
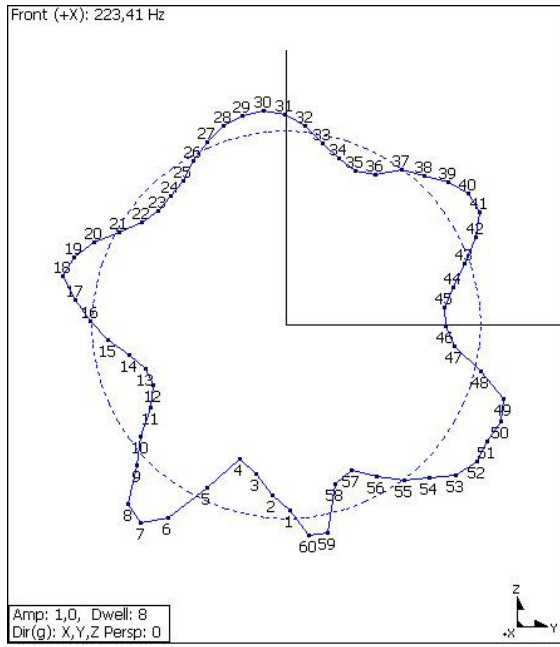
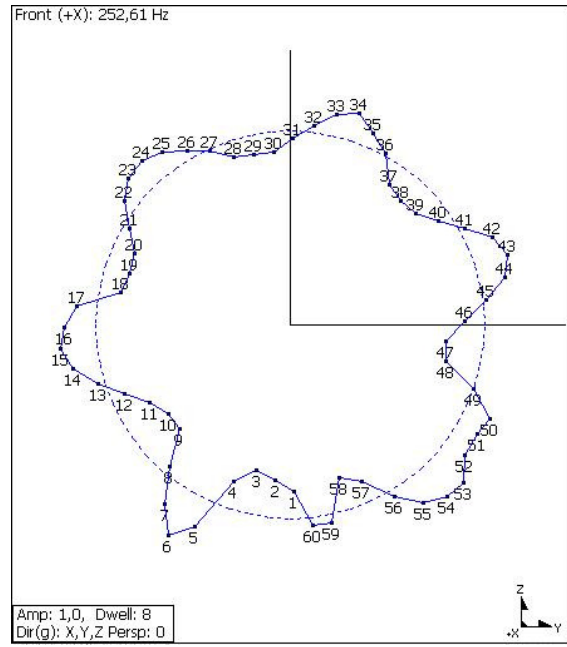

Figure D. 12 mode 4 at 191 Hz.





**Figure D. 5 mode 5 at 223 Hz.**



**Figure D. 6 mode 6 at 253 Hz.**

## Appendix E

### Estimated in-plane mode shapes of the tread

These measurements were taken with the shaker connected at the bottom of the tire (point number 1) and a load of 4000 N applied to the tire. The mode shapes have all the same shape, so only one position of the shaker is used to measure and identify the mode shapes. The remaining shapes are equal and therefore not presented.

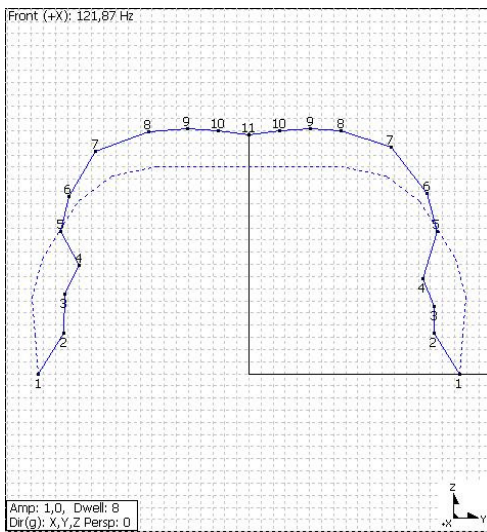

Figure E. 1 mode 1½ at 122 Hz.

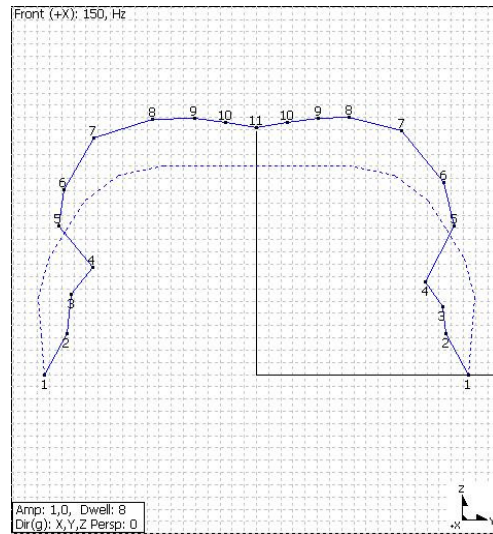

Figure E. 2 mode 2½ at 150 Hz.

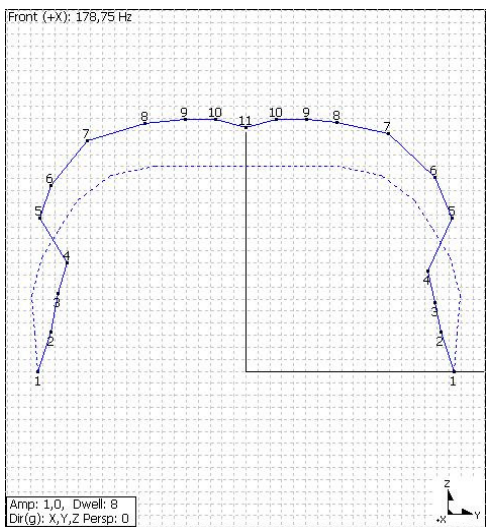

Figure E. 3 mode 3½ at 178 Hz.

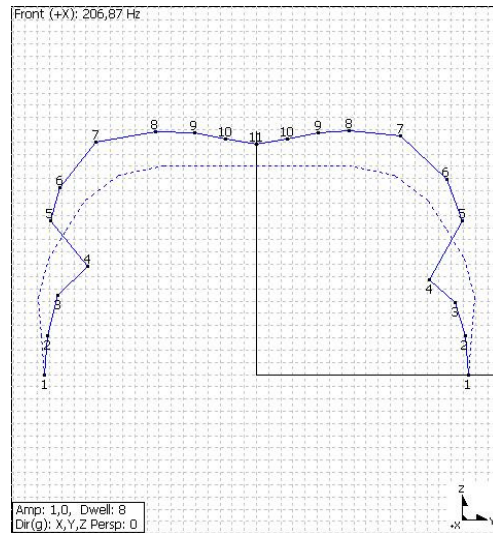
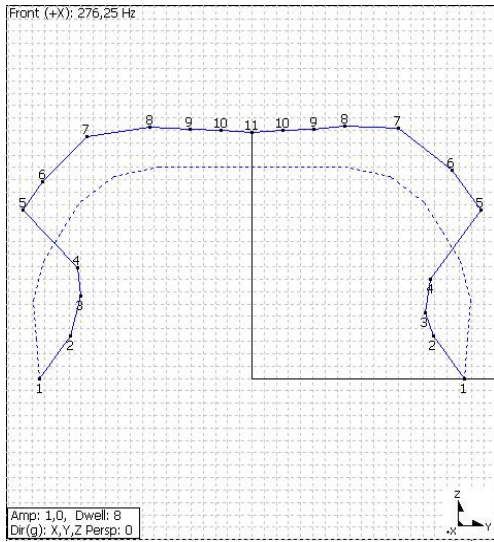
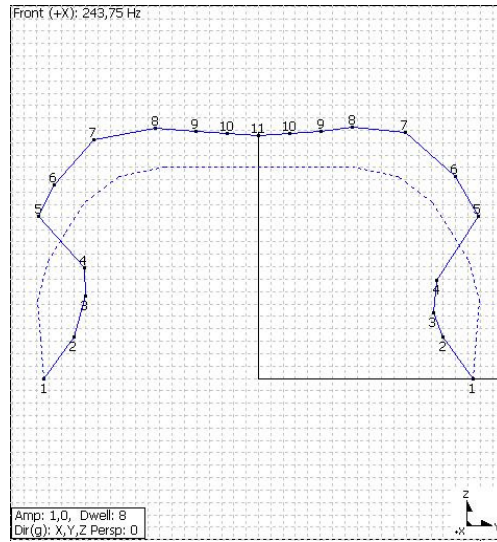

Figure E. 4 mode 4½ at 207 Hz.



**Figure E. 5 mode 5½ at 276 Hz.**



**Figure E. 6 mode 6½ at 243 Hz.**

# Appendix F

## Frequency response functions

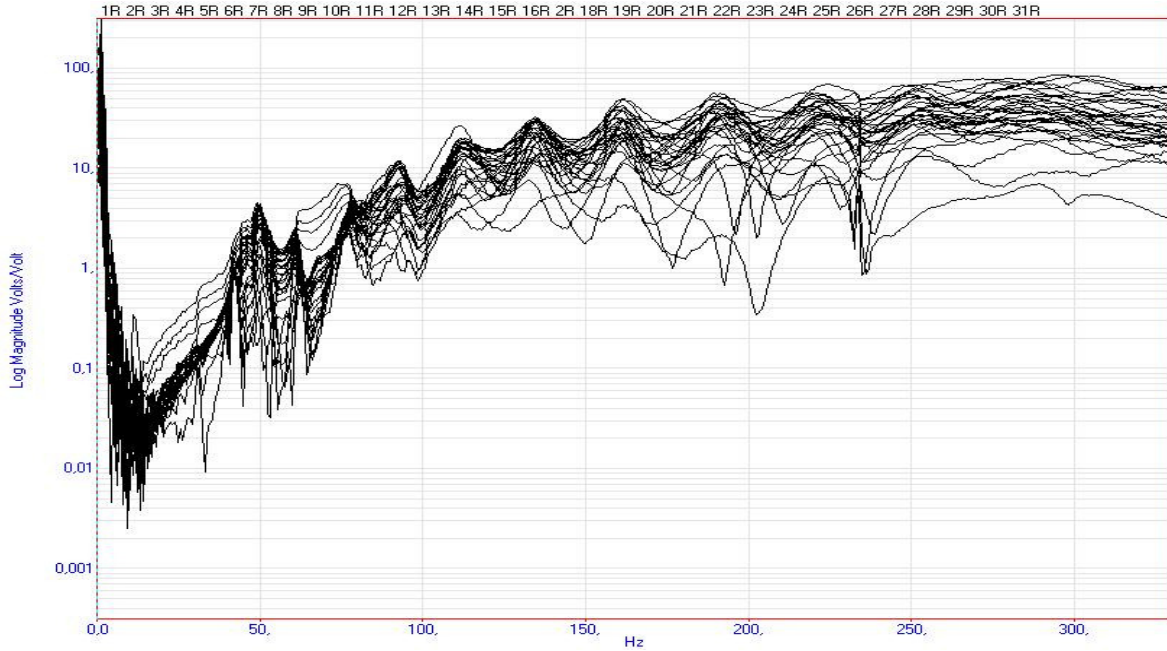

Figure F. 1 FRF no load

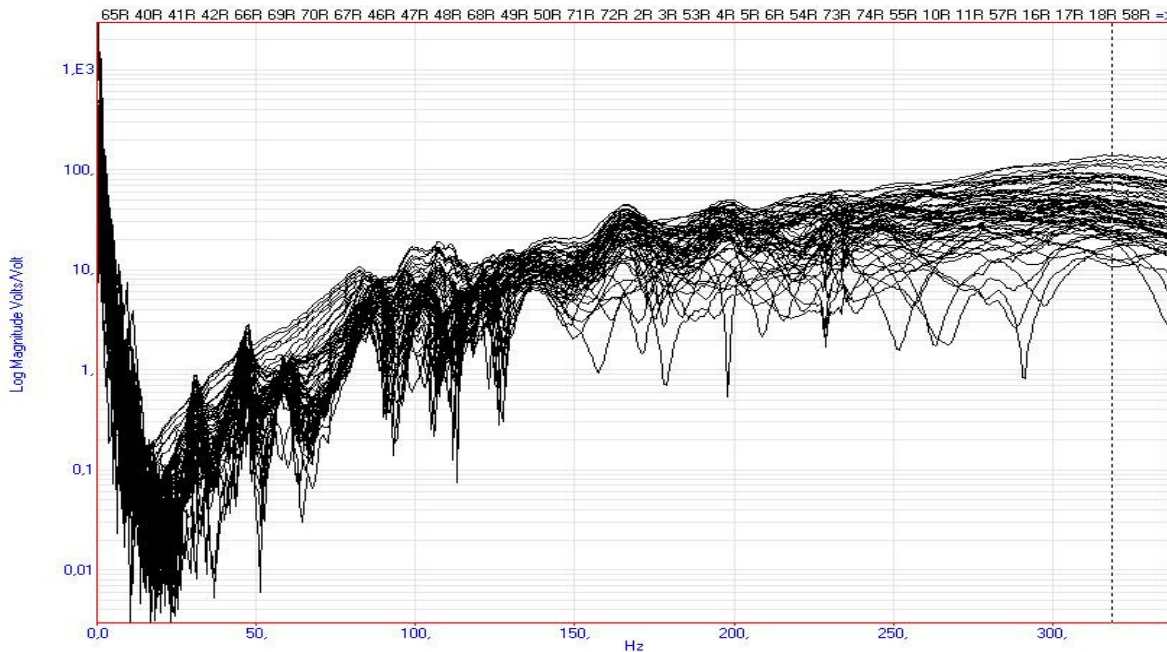

Figure F. 2 FRF half with load

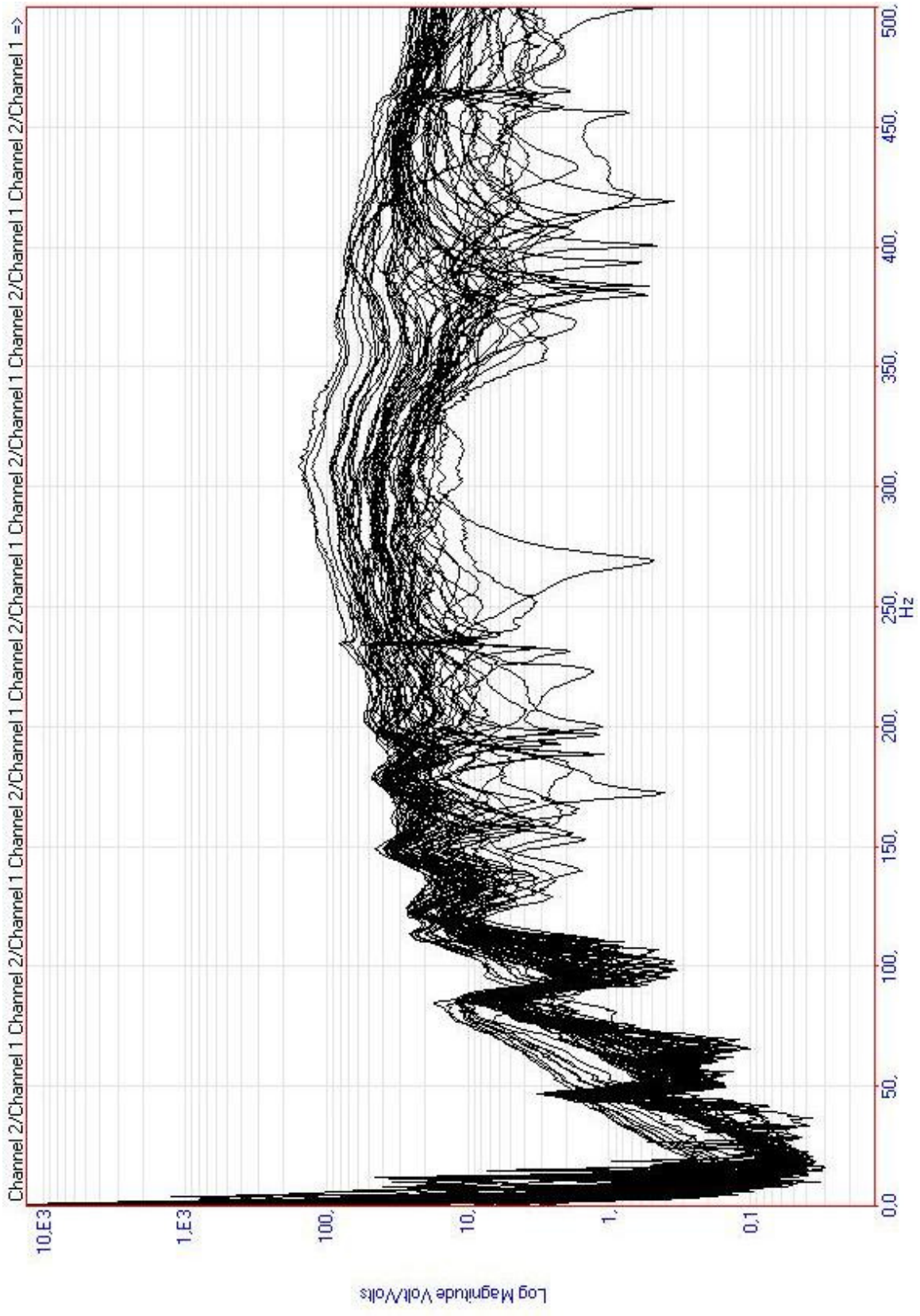

Figure F. 3 FRF whole with load