

Modelling and control of process industry batch production systems

Citation for published version (APA):

Beek, van, D. A., Ham, van, A., & Rooda, J. E. (2003). Modelling and control of process industry batch production systems. In E. F. Camacho, & L. Basanez (Eds.), *Proceedings of the 15th IFAC world congress : 21-26 July 2002, Barcelona, Spain* Pergamon.

Document status and date:

Published: 01/01/2003

Document Version:

Accepted manuscript including changes made at the peer-review stage

Please check the document version of this publication:

- A submitted manuscript is the version of the article upon submission and before peer-review. There can be important differences between the submitted version and the official published version of record. People interested in the research are advised to contact the author for the final version of the publication, or visit the DOI to the publisher's website.
- The final author version and the galley proof are versions of the publication after peer review.
- The final published version features the final layout of the paper including the volume, issue and page numbers.

[Link to publication](#)

General rights

Copyright and moral rights for the publications made accessible in the public portal are retained by the authors and/or other copyright owners and it is a condition of accessing publications that users recognise and abide by the legal requirements associated with these rights.

- Users may download and print one copy of any publication from the public portal for the purpose of private study or research.
- You may not further distribute the material or use it for any profit-making activity or commercial gain
- You may freely distribute the URL identifying the publication in the public portal.

If the publication is distributed under the terms of Article 25fa of the Dutch Copyright Act, indicated by the "Taverne" license above, please follow below link for the End User Agreement:

www.tue.nl/taverne

Take down policy

If you believe that this document breaches copyright please contact us at:

openaccess@tue.nl

providing details and we will investigate your claim.

MODELLING AND CONTROL OF PROCESS INDUSTRY BATCH PRODUCTION SYSTEMS

D.A. van Beek¹, A. van den Ham, J.E. Rooda

*Eindhoven University of Technology, Dept. of Mechanical Engineering,
P.O. Box 513, 5616 JB Eindhoven, Netherlands*

Abstract: Many models of process industry batch production systems are of a continuous-time/discrete-event (CT/DE) nature: physical processes are modelled using CT specifications, operating procedures are modelled using DE specifications. For scheduling of batch production systems, special purpose tools are available. The Chi language is a CT/DE language with high level DE language elements. This makes it possible to model physical processes using CT and/or DE specifications. It also makes it possible to solve scheduling problems in Chi, and to integrate the scheduler with the model of the batch production systems. The advantages of this approach are illustrated by means of four case studies.

Keywords: hybrid systems, modelling, simulation, batch control, industrial production systems, chemical industry, scheduling algorithms

1. INTRODUCTION

Production systems can be divided into two types: discrete production systems and production systems of the so-called process type. Discrete production systems can be characterized by the fact that discrete products need to be positioned. In production systems of the process type, on the other hand, there is no positioning of intermediate products. This is especially clear when materials are in gaseous, liquid or powder form. For process type production, the distinction can be made between batch production and continuous production. In batch processes, several process steps are executed in one place, usually a tank such as a batch reactor. In the reactor, operating conditions vary as a function of time. After execution of the process steps, the materials are transported (Rijnsdorp, 1991).

Simulation languages and tools for the analysis of production systems of the process type and discrete production systems are usually quite different. Simulation languages for process type systems tend to be equation oriented whereas discrete production systems are usually modelled in a purely discrete-event way. For batch

production systems, a combination of continuous-time (CT) and discrete-event (DE) techniques is required. DE techniques are required for the modelling of discontinuous changes in the physical system. The opening and closing of valves, for example, are usually modelled as instantaneous actions that take place at a moment in time. DE techniques are also required for the modelling of parts of the digital control systems in the form of operating procedures (Barton and Pantelides, 1994), supervisory control, logic control, or sequence control. If the batch production system is a multiproduct plant with shared resources, scheduling algorithms can easily become too complex to be specified using combined CT/DE process simulation languages. In such a case, special purpose tools may be required to solve the scheduling problem.

It is the purpose of this paper to indicate the importance of high-level discrete-event concepts for modelling, simulation, and control of batch production systems. High level DE concepts are useful for the specification of physical systems and control systems. For physical system specification, high level DE concepts allow a high level of modelling abstraction to be used. As the level of abstraction increases, the difference between the model and the modelled reality increases, but at the

¹ Corresponding author.
E-mail address: d.a.v.beek@tue.nl

same time, model complexity and the modelling effort decreases (Van de Mortel-Fronczak *et al.*, 2001). For control system specification, high level DE concepts allow the specification of complex scheduling strategies. The use of DE techniques is clarified by means of four case studies, all dealing with models of batch production systems, that are ordered in increasing level of abstraction, and increasing level of DE modelling. The cases have all been modelled and simulated using the χ , or Chi, (Van Beek and Rooda, 2000) language; the scheduling strategies have also been specified completely in χ . Due to space limitations of this paper, the χ specifications are not given. The χ language is a hybrid language that can be used for specification, verification, simulation, and control of discrete-event systems, continuous-time systems, and combined systems. Chi specifications are textual or symbolic; the figures of batch plants in this paper are plain drawings.

The first case study is a batch plant for the production of ethanol (Van Beek *et al.*, 1995). The only DE parts of the model are the operating procedures and the modelling of valves that operate instantaneous. The second case study is a pipeless batch plant (Van den Ham, 2001). In this plant, there is no piping between the reactors. Instead, small reactors move through the plant and connect to the different stations for processing. The plant is computer controlled so that a high level of flexibility is obtained. The third case study is a multiproduct fruit juice blending and packaging plant (Fey, 2000). The plant consists of a preparation department, where blending takes place, and a packaging department. The plant is controlled using an advanced predictive scheduling strategy, which creates a schedule for a week in advance. The preparation department is modelled using equations to model the levels in the tanks and the flows. The packaging department is modelled in a discrete-event way. The last case study is that of a brewery which consists of a large number of tanks and a complex network of connecting pipes and manifolds. When a batch flows from a source tank to a destination tank, it is always first processed in the destination tank before it goes on to the next tank. This constraint makes it possible to use a purely discrete-event model. The plant is controlled using an advanced reactive scheduling strategy.

2. BATCH PRODUCTION OF INDUSTRIAL ETHANOL

This case treats a simplified plant for batch production of industrial ethanol, which is described in (Van Beek *et al.*, 1995). The ethanol is produced as a result of the biodegradation of glucose by yeast in a fed-batch mode. The fermentation process is modelled in detail, using an index 1 DAE (differential algebraic equation) system, in order to study the effect of the settings of the parameters on the quality and the efficiency of the production process. The plant consists of two fermentors, two product tanks, a feed tank, a sterilizer,

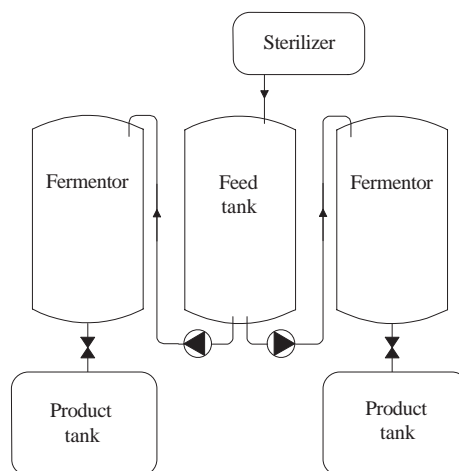

Fig. 1. Flowsheet of a batch plant for ethanol production.

pumps and valves. Figure 1 shows the flowsheet of the plant. The discrete-event parts of the models are confined to the control processes for the operation of the fermentors, the level control of the feed tank, the batch scheduler process, and the switching of the valves and pumps.

3. A PIPELESS BATCH PLANT

3.1 The pipeless production principle

In conventional batch production systems, there is a fixed number of tanks/reactors that are connected by means of a fixed piping network. In a pipeless plant, small mobile reactors are used, in which each of the necessary processing steps can take place. The reaction mixture no longer flows from tank to tank, but stays in the same reactor. The different mobile reactors that are present in the plant can each carry a different kind of product. The system is completely computer controlled. Advantages of pipeless production are:

- A computer controlled pipeless plant is very flexible. Small amounts of highly specific products can easily be produced. New recipes can be added into the computer control system.
- The time to market becomes much shorter. Because of the low volume of the reactors in a pipeless plant, new production processes that have been developed at a small laboratory scale can be transformed for pipeless production relatively easily. It is no longer necessary to upscale the production processes to the large volumes of conventional batch reactors.

The pipeless production concept is relatively new, and currently mainly applied for simple processes, such as mixing of different components. In order to investigate the possibilities for pipeless production of fine chemical products, models of pipeless plants have been developed. One of these models deals with pipeless production of a high solid polystyrene latex.

Latex is formed by emulsion polymerization of a monomer. The latex produced in the plant should contain 50wt% (weight percentage) of polystyrene. In a conventional batch plant, there can be a continuous feed of monomer. In a pipeless plant, monomer is injected at specific points of time. The reaction starts with 20wt% of monomer. When the conversion of the reactor fluid reaches the value of 0.41, 10wt% of new monomer is injected. As soon as the total amount of injected monomer has reached 50wt%, no more injections take place. To avoid coagulation during the emulsion polymerization, it is also necessary to inject emulsifier. Towards the end of the reaction, the reaction rate decreases. In order to compensate for this, the temperature is then increased. When the conversion has reached 0.99, the reactor is emptied and cleaned.

3.2 Pipeless plant

Figure 2 shows a schematic overview of the pipeless plant. The plant consists of eight processing stations. Every process station is modelled as a separated process. A new order arrives in the system and is allocated to an empty reactor in Buffer 1. The reactor is then sent to the next process station, which is the filling station. The filling station injects the raw materials into the reactor, whereafter the reaction starts and the reactor is sent to Buffer 2. During the reaction, the reactors are parked in this buffer. The reactor leaves the buffer when a next processing step needs to take place. After such a processing step, the reactor returns to Buffer 2, where it is parked again. This cycle goes on until the reaction is completed, whereafter the reactor is sent to the emptying station. Heating and cooling is done in a process station by means of a removable jacket. Monomer and emulsifier injection take place at the injection station. As soon as possible after monomer injection, a sample is taken in the measurement station, and the conversion is determined. When the reaction is completed, the reactor is sent to the emptying station. The high solid polystyrene latex is removed from the reactor. The reactor is cleaned in the cleaning station, and subsequently returns to Buffer 1. The reactor is then available for a new order.

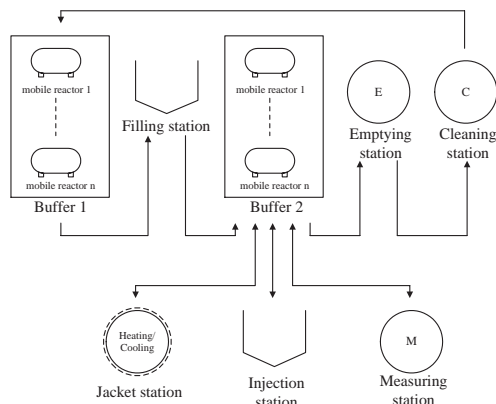

Fig. 2. Overview of the pipeless plant.

3.3 Modelling

The reaction itself is modelled by an index 1 DAE system, consisting of approximately 30 equations. The control system of the plant determines when to cool, heat, or inject, based on the measurements of a gas chromatograph and thermocouple. The gas chromatograph, used in the measuring station, measures the conversion by taking a sample from the reaction. It takes approximately 5 minutes to analyze the sample and compute the conversion. Because of this delay, the computed conversion is the value of the conversion of 5 minutes earlier. The current conversion value is derived from the conversion computed from the sample. Temperature samples are used to determine the value of the temperature dependent reaction rate. The thermocouple takes samples of the temperature of the reactor every 30 seconds.

Both buffers are modelled as discrete event processes. Buffer 1 is a First In First Out (FIFO) queue. In Buffer 2 on the other hand, the controller determines when the reactors leave the queue for the next processing step. When a command is given, the reactor is picked out of the queue and is sent to the (FIFO) queue of corresponding process station.

3.4 Results

Figure 3 shows simulation results of a pipeless plant with two reactors. It takes approximately 3 minutes of real time to simulate 25 hours in the pipeless plant model. At time zero, the first reactor starts processing. The first injection of monomer takes place when the conversion reaches a value of 0.41. Monomer is injected three times. The conversion is not linear in time, because of the fluctuating temperature, which influences the polymerization rate. The total production time of the latex equals approximately 18 hours.

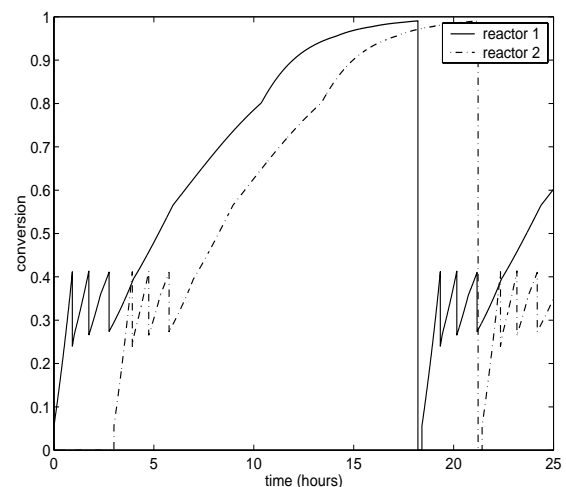

Fig. 3. Simulation results of the pipeless batch plant

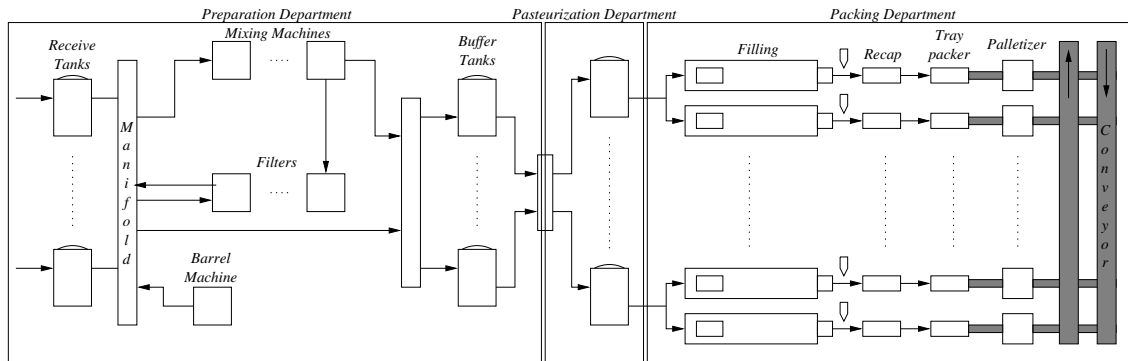

Fig. 4. Simplified overview of the fruit juice production facility.

4. A FRUIT JUICE BLENDING AND PACKAGING PLANT

A detailed treatment of the fruit juice production facility is presented by Fey (2000). A simplified overview of the plant is shown in Figure 4. The production of juices takes place in three departments: the Preparation Department, the Pasteurizing Department, and the Packaging Department. In the Preparation Department, the juice is prepared in batches according to a specific recipe. When the preparation is finished, the juice is pumped to the Pasteurizing Department, and subsequently to the Packaging Department, where it is packed in different types of cartons.

In general, two different ways of preparing can be used. The first method is preparation by in-tank dilution: first, all ingredients are pumped into one receiver tank, then the correct amount of water is added, finally the blend is stirred. The second method is preparation by in-line dilution Fey (2000) by means of a blender: fruit concentrates are pumped into a tank and stirred. Next, the juice is pumped to a continuous blender to add water, and in some cases sugar, to the concentrate. The output of the blender is pumped into a buffer tank.

4.1 Scheduling

A large variety of blends in many different packages are produced. The increasing production volumes have led to the need to automate the scheduling of the orders produced in the plant. Scheduling takes place on a weekly basis. As a result of equipment failures, or other unforeseen circumstances, orders may be rescheduled during the week. First, the schedule of the Packaging Department is generated. Subsequently, the schedule of the Preparation Department is generated. The most important criteria are minimization of the

- total tardiness,
- sum of sequence dependent setup times,
- number of synchronizations.

The need for synchronizations are a result of the fact that the same blend may be packed in different cartons. Apple juice, for example, is packed in liter packs and in small 0.25 liter packs. Therefore, the batch for

1 liter packs and the batch for 0.25 liter packs are packed at different packaging lines, but they should overlap in the preparation department. In this way, the two batches are combined, or synchronized, in the preparation department.

The scheduling problem is NP-hard, so that an optimal solution cannot be found within a reasonable amount of time. A tabu search local search algorithm was developed by Peters (1999) to find a suboptimal schedule within a reasonable amount of time. Table 1 shows the results of a comparison of the tabu search scheduler with the results of a human scheduler on the basis of six different schedules.

Table 1. Scheduling results.

Criteria	Tabu search	Human scheduler
Total tardiness	1.5 hours	4.7 hours
Sum of sequence dependent setup times	77 hours	72 hours
Missed synchronizations	1%	25%
Scheduling time	1 - 10 minutes	approx. 8 hours

The experiments show that the designed algorithm outperforms the human scheduler on total tardiness and missed synchronizations.

4.2 Modelling

To reduce the complexity of scheduling problems, additional assumptions are usually necessary. In this case, assumptions were: no failures, non-stochastic processing times, no shared pumps. As a result of such simplifications, a calculated schedule may require slight modifications in real-life. To investigate the effect of such differences, the calculated schedule can be tested on a CT/DE simulation model of the plant.

Figure 5 shows how a batch (A), that is prepared using in-line dilution, occupies five resources over time. This is most elegantly modelled by means of differential equations describing the derivatives of the volumes of the tanks as a function of the incoming and outgoing flows. For the packaging line, however, discrete-event specifications lead to shorter and clearer specifications, that simulate much faster, because unnecessary detail is omitted.

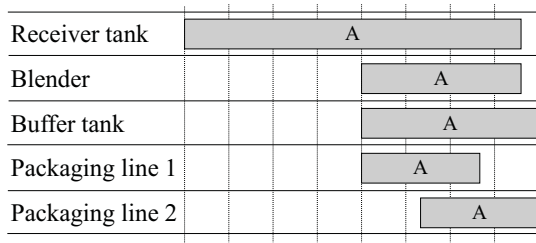

Fig. 5. Gantt chart of a batch using in-line dilution (Fey, 2000).

5. A BREWERY

Several studies have been performed in a brewery. These studies have not been published previously. A large part of the brewery has been rebuilt using new and completely automated production processes. Below, some details are given regarding how modelling and simulation has been used to support the redesign of the plant. A part of the plant that has been redesigned consists of some 70 high volume tanks, that are interconnected by a complex network of pipes, valves and pumps. One of the processes taking place is fermentation of the wort. The brewing tanks deliver the wort to the fermentation tanks. After fermentation, the so-called 'green beer' is pumped to aging tanks. Filling and emptying of a fermentation tank takes several hours. The fermentation process itself takes several days. The tanks are divided into clusters, an example of which is shown in Figure 6. There are several shared resources in the system: many tanks share the same pipes, pumps, cleaning equipment, and processing equipment. In Figure 6, groups of three fermentation tanks share the same pipe. This means that only one of these three tanks can perform an action using the pipe at the same time. Some actions are: filling, emptying, and cleaning.

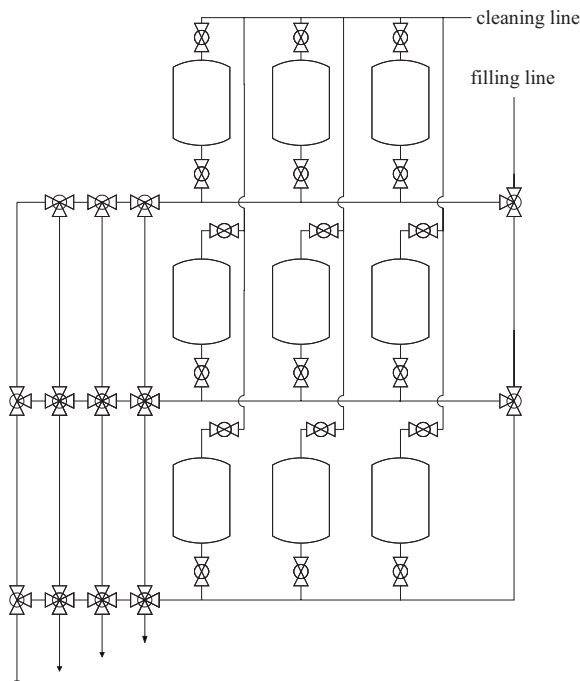

Fig. 6. A cluster of nine tanks on three connection pipes.

The purpose of the studies was to evaluate the performance of different physical configurations of some parts of the system, and to evaluate different scheduling strategies, by means of modelling and simulation. The performance was measured in terms of throughput, that should be maximized, and waiting times, that should not exceed certain maximum values. Figure 6 shows a configuration of 3 groups of 3 tanks that are connected to the same pipe. For 12 tanks, two possible configurations are 4 groups of 3 tanks, or 3 groups of 4 tanks. Scheduling strategies are discussed below.

5.1 Modelling

The model of the plant specifies the states of all tanks, and all other resources, such as the piping system. The scheduler is also part of the model. The models are all completely discrete-event based. Filling, fermentation, and emptying are modelled as states that are active during a certain period of time. At the end of the filling of a batch, the volume of the tank is discontinuously increased by the batch size.

The quality of beer degrades by storing, so that seasonal changes in demand cannot be eliminated by means of large stocks of bottled beer. System operation is most critical in the summer when demand is highest, and the system needs to operate at maximum throughput. Therefore, the control system of the model tries to achieve maximum throughput, while at the same time trying to maintain optimal quality of the beer. Quality of the beer is degraded when actions are executed too late: in fact, for each action there is a maximum waiting time. A complicating factor is that the fermentation times are not constant: since fermentation is done by micro-organisms, the fermentation times are affected by many factors. These factors have been modelled by a stochastic variation in the fermentation times.

5.2 Scheduling

The control system makes use of a predictive and a reactive scheduling strategy. The brewing times are predictable, therefore the starting times of the batches in the brewing cellar are determined in advance. The stochastic nature of the fermentation process, however, makes predictive scheduling for the fermentation processes of little use. Therefore, for these processes, reactive scheduling is used: allocation and sequencing decisions take only the current state of the system into account.

Scheduling deals with sequencing and allocation. Allocation deals with the choice of an available tank or pipe from a number of similar tanks or pipes. Sequencing deals with the choice between actions. Because of the large number of tanks, and the many shared resources, in many cases a choice needs to be taken among different possible actions. The most important actions are

filling, emptying, or cleaning of a fermentation tank; or (re-)cleaning of pipes. Re-cleaning is required when a clean pipe has not been used for more than two days. Such a pipe must be re-cleaned before it may be used again.

Due to the complexity and the stochastic nature of the brewery, the quality of the reactive scheduling algorithms can only be assessed in a real-life situation, or by integrating the scheduler in a valid model of the brewery. Since in this case, the real life system was not yet available, simulation models were the only option. Therefore, integration of the scheduler and the physical system in the model is essential. By means of simulation, the quality of the different scheduling strategies are compared. Each run of a simulation model produces a Gantt chart; and a table of the main output results, such as average throughput and number of times that a maximum waiting time is exceeded. Some of the results are:

- Waiting times are best reduced by allocating tanks on the basis of the utilization rate of tank groups and clusters. A tank group shares the same filling/emptying pipe; a tank cluster consists of a number of tank groups which share a number of filling/emptying pipes. Tank groups and clusters with a low utilization rate in the immediate history are given a high priority. In this way, the batches are evenly spread out over the system, reducing the chance of conflicts.
- Claims on pipelines are used to reduce harmful waiting times. Waiting times on processing actions are caused by the unavailability of resources required to form a circuit. A circuit to fill a fermentation tank, for example, consists of a brewing tank, a fermentation tank, and a network of pipes connecting the two tanks. When a critical action is foreseen to take place in the immediate future, the required piping network is claimed a short time in advance to avoid less urgent actions to occupy the pipes.
- By increasing the average fermentation time, of an existing physical tank-piping configuration, by one day, the number of conflicting actions was considerably reduced. As a result, the number of harmful waiting times decreased considerably, whereas throughput was hardly affected.

6. CONCLUSIONS

Four case studies of modelling batch production systems in the process industry have been discussed. In all models, discrete-event concepts are used for modelling parts of the system. The ethanol production facility is an example of a plant that is mainly specified using equations. The operating procedures are straightforward. The pipeless batch plant is treated as an example of a system where high level CT and DE modelling techniques are needed. The state of the reactions deter-

mines when the control system can perform the next control action. Therefore, the reactions are modelled by means of an index 1 DAE system. The control system needs to deal with many resources. For this purpose, DE techniques are better suited. The fruit juice blending and packaging plant is an example of a plant where high level DE techniques are required to determine a good schedule. For testing the generated schedule, a CT/DE model of the plant is needed. One department of the plant (preparation) is best specified using equations, and the other department (packaging) is best specified using DE techniques. The brewery is best specified using DE modelling techniques. Because of the stochastic nature of the fermentation times, the plant is controlled using an advanced reactive scheduler. In order to improve and test the quality of the scheduling strategy, integrated modelling of the control system, consisting of the scheduler, and the physical (controlled) system is essential.

7. ACKNOWLEDGMENTS

The authors would like to thank J. Meuldijk for providing the necessary chemical background for the second case study, and they would like to thank the anonymous referees for helpful comments on the draft of this paper.

REFERENCES

- Barton, P. I. and C. C. Pantelides (1994). Modeling of combined discrete/continuous processes. *AIChE* **40**(6), 966–979.
- Fey, J. J. H. (2000). Design of a Fruit Juice Blending and Packaging Plant. PhD thesis. Eindhoven University of Technology.
- Peters, R. (1999). Scheduling algorithms for the packaging department of Riedel drankenindustrie. Master's thesis. Eindhoven University of Technology.
- Rijnsdorp, J. E. (1991). *Integrated Process Control and Automation*. Elsevier, Amsterdam.
- Van Beek, D. A. and J. E. Rooda (2000). Languages and applications in hybrid modelling and simulation: Positioning of Chi. *Control Engineering Practice* **8**(1), 81–91.
- Van Beek, D. A., S. H. F. Gordijn and J. E. Rooda (1995). Integrating continuous-time and discrete-event concepts in process modelling, simulation and control. In: *Proceedings of the First World Conference on Integrated Design and Process Technology*, pp. 197–204.
- Van de Mortel-Fronczak, J.M., J. Vervoort and J.E. Rooda (2001). Simulation-based design of machine control systems. In: *Proceedings of the European Simulation Multiconference*, pp. 331–338.
- Van den Ham, A. (2001). A pipeless batch plant for emulsion polymerization. Systems Engineering Technical Report SE 420280. Eindhoven University of Technology.