

Weight compensation for the NANOMEFOS

Citation for published version (APA):

Tas, van der, S. G. (2007). *Weight compensation for the NANOMEFOS*. (DCT rapporten; Vol. 2007.060). Technische Universiteit Eindhoven.

Document status and date:

Published: 01/01/2007

Document Version:

Publisher's PDF, also known as Version of Record (includes final page, issue and volume numbers)

Please check the document version of this publication:

- A submitted manuscript is the version of the article upon submission and before peer-review. There can be important differences between the submitted version and the official published version of record. People interested in the research are advised to contact the author for the final version of the publication, or visit the DOI to the publisher's website.
- The final author version and the galley proof are versions of the publication after peer review.
- The final published version features the final layout of the paper including the volume, issue and page numbers.

[Link to publication](#)

General rights

Copyright and moral rights for the publications made accessible in the public portal are retained by the authors and/or other copyright owners and it is a condition of accessing publications that users recognise and abide by the legal requirements associated with these rights.

- Users may download and print one copy of any publication from the public portal for the purpose of private study or research.
- You may not further distribute the material or use it for any profit-making activity or commercial gain
- You may freely distribute the URL identifying the publication in the public portal.

If the publication is distributed under the terms of Article 25fa of the Dutch Copyright Act, indicated by the "Taverne" license above, please follow below link for the End User Agreement:

www.tue.nl/taverne

Take down policy

If you believe that this document breaches copyright please contact us at:

openaccess@tue.nl

providing details and we will investigate your claim.

Weight compensation for the NANOMEFOS

Sebastiaan van der Tas
DCT 2007.060

May 2007

Contents

1	Introduction	2
2	Function and requirements	4
3	Solutions	6
3.1	Elastic deformation	6
3.2	Standard air pressure cylinders	6
3.2.1	Function of air pressure cylinders	6
3.2.2	Experiments with cylinders	7
3.2.3	Use of cylinders in weight compensation	12
4	Conclusion	13
A	Leaf spring	14
A.1	Elastic deformation	14

Chapter 1

Introduction

Measuring of lenses or mirrors with high accuracy is very important for use in astronomy and also for the semiconductor industry because of the use of those in wafer steppers. Nowadays it is possible to measure with a high accuracy with the use of interferometry, but these measurements are only useful for just one product type. Coordinate measurement machines are universal but they make contact with the surface and the accuracy is not high enough.

The NANOMEFOS is designed to measure products with a size up to 500 mm in diameter with an uncertainty of 30 nm within 15 minutes. Therefore the setup of Figure 1.1 has been designed by Rens Henselmans [1]. In this figure one can see the spindle (1) with the product attached on it which can rotate about the θ -axis. Above the spindle the probe (2) is placed which can rotate along the ψ -axis and is attached to the Z-stage (3). The Z-stage moves along the Z-axis through the R-stage (4) which can move along the R-axis. These translations and rotations make it possible to place the probe on all required positions above the product perpendicular to the surface.

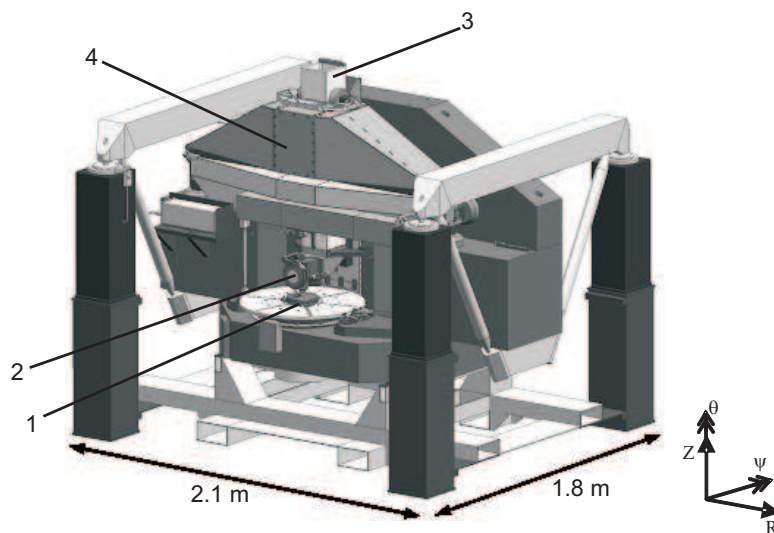

Figure 1.1: Overview of the NANOMEFOS.

The Z-stage and the R-stage consist of a force frame and a position frame. The force frame is needed to withstand pre-load for air bearings. Figure 1.2 shows the position and force frames of the Z-stage (left) and the R-stage (right).

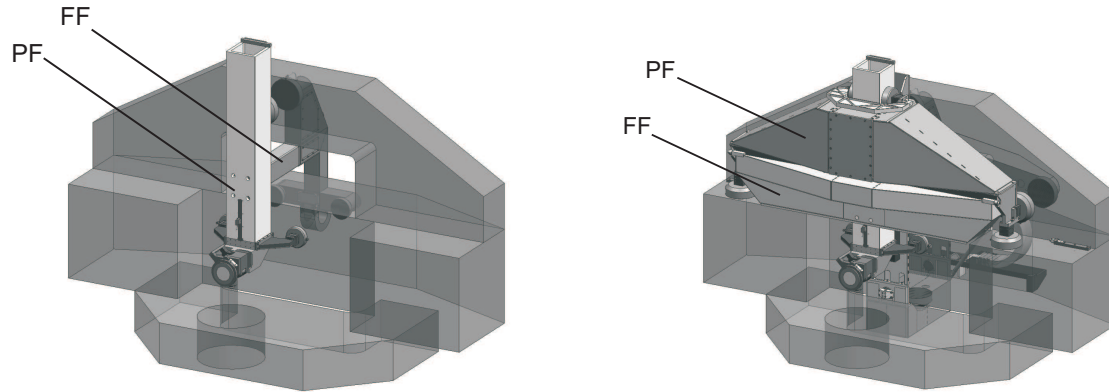

Figure 1.2: Position frame (PF) and force frame (FF) of the Z-stage (left) and the R-stage (right).

The Z-stage weighs about 75 kg and is actuated by a linear motor. However, this motor is not meant to carry the whole mass of the Z-stage because this will generate heat which is undesirable. The goal of this project is to design a weight compensation for the Z-stage in order to relieve the actuator from the gravitational force. The performance of the measurement machine may not be influenced too much by the weight compensation. The NANOMEFOS is designed to achieve a positioning accuracy of $0.1 \mu\text{m}$ and the weight compensation should also be designed to achieve that accuracy.

A spring may be a possible solution to achieve a constant force over a certain distance. The simplicity and reliability are big advantages of such a solution. Unfortunately, the available space for the weight compensation is limited and the spring volume might be too big.

Another solution may be the usage of air pressure, which is available in the machine because of the air bearings. A major advantage of air pressure is that a big force can be created within a small volume but one has to take notice of the friction in the cylinders which will affect the performance of the measurement machine.

Chapter 2

Function and requirements

The weight of the whole Z-stage together with the probe is about 75 kg so the weight compensation must deliver about 750 Newton. The Z-stage consists of a force frame and a position frame. The air bearings are attached to the force frame which can withstand the forces which arise from pre-loading the air bearings. Due to these forces the force frame will face stress and hysteresis, but the position frame is attached to this frame in such way that these disturbances will not be translated to the position frame.

For the R-stage the same kind of construction is used: the force frame is designed to withstand the forces of the pre loaded air bearings and the position frame is attached to the force frame in such way that the deformations of the force frame are not translated to the position frame.

The constructions described above are important for the weight compensation because the weight compensation will create a force between these two force frames in order to prevent stress and hysteresis in the position frames. More specific, the position where the force will be exerted on the force frame of the Z-stage must lie on the vertical line through the center of mass of the whole Z-stage (including the probe) to prevent undesirable moments.

In Figure (2.1) the location of the weight compensation is indicated with the orange arrows. The force frame of the Z-stage is colored green, and the force frame of the R-stage is colored yellow. Because of the layout of the NANOMEFOS the available volume of the weight compensation is limited. At the backside the force frame of the R-stage limits this volume, at the front side the ceramic beam (position frame) of the Z-stage and the measurement volume must be taken into account. The width of the volume is bounded by two air bearings of the Z-stage. These restrictions create an available volume with a height of 240 mm, a width of 220 mm and a depth of 50 mm.

The locations where the weight compensation can be attached to the force frames are indicated in Figure (2.2). The yellow colored locations are at the R-stage, the green location is at the Z-stage.

Air pressure of 5.5 bar is available in the NANOMEFOS because of the air bearings. This pressure can also be used for the weight compensation. The NANOMEFOS is designed to achieve a positioning accuracy of 0.1 μm and this may not be deteriorated by the weight compensation.

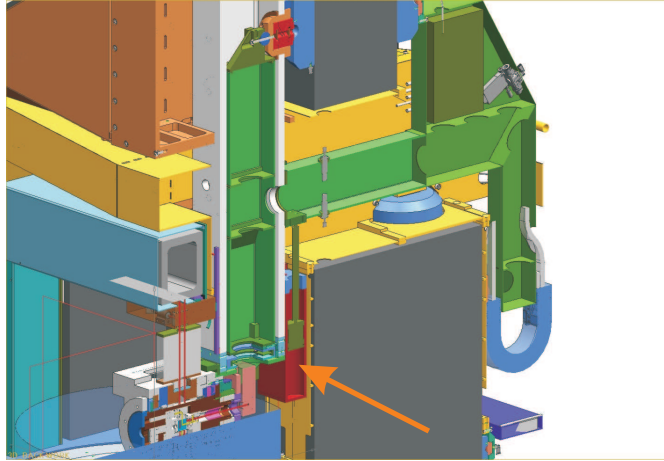

Figure 2.1: Location of the weight compensation inside the NANOMEFOS indicated by the orange arrow.

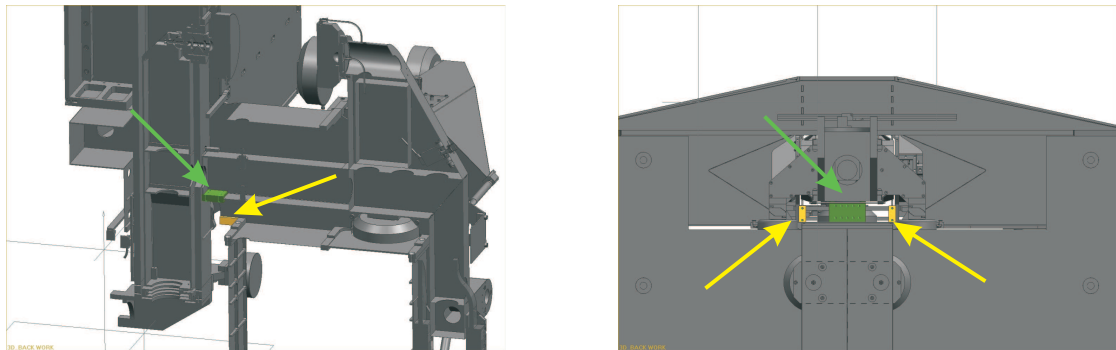

Figure 2.2: Locations where the weight compensation can be attached to the R-stage (yellow) and the Z-stage (green).

Chapter 3

Solutions

3.1 Elastic deformation

A very simple solution for a weight compensation can be a construction with a spring which can produce a constant force over the required distance. Major advantages of such a solution are the simplicity of the construction, the costs and the absence of external energy sources which can fail. Unfortunately it is very difficult to produce a constant force over a long distance with a spring. A possible design may be a leaf spring [3], but this spring delivers a maximum force of 14.2 Newton within the available volume (see appendix (A)).

3.2 Standard air pressure cylinders

3.2.1 Function of air pressure cylinders

As mentioned before, a major advantage of the use of air pressure is that a big force can be created within a small volume. But air pressure is not always available, fortunately at the NANOMEFOS there is a source for air pressure because of the presence of air bearings. The air pressure can be transformed in a force with cylinders. A standard double acting cylinder with a single piston rod is shown in Figure 3.1. It consists of a cylinder (1) with two end caps (2). A piston (3) can move inside the cylinder and is attached to the piston rod (4). When air flows into the cylinder the pressure rises and a force will act on the piston. (or the piston will move) The theoretical force can be calculated by Eq.(3.1).

$$F = p_1 * A_1 - p_2 * A_2 \quad (3.1)$$

Where p_1 is the pressure compartment 1, A_1 is the area of the piston, p_2 is the pressure in compartment 2 and A_2 is the area of the piston minus the area of the piston rod. So A_2 is smaller than A_1 and the resulting force will be positive when $p_1 = p_2$.

At the NANOMEFOS air pressure of 5.5 bar is present. The force that has to be exerted on the force frame is about 750 Newton. This means that the area of the piston must be at least:

$$A_1 = \frac{F + p_2 * A_2}{A_1} = \frac{750 + 0 * A_2}{5.5 * 10^5} = 1.364 * 10^{-3} m^2 \quad (3.2)$$

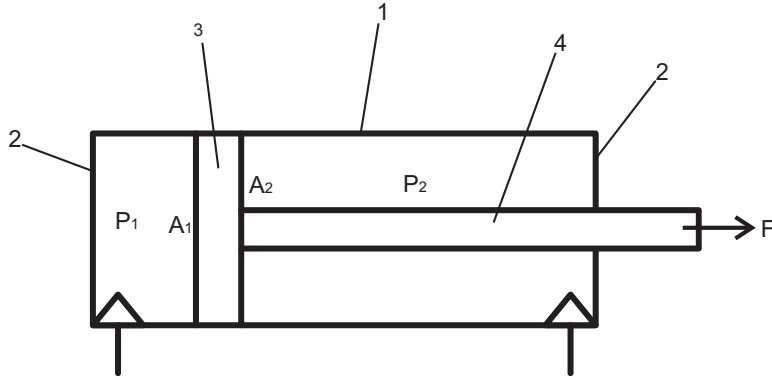

Figure 3.1: Schematic drawing of a double acting, single rod, pneumatic cylinder.

This means that a piston diameter of: $2 * \sqrt{\frac{1.364 * 10^{-3}}{\pi}} = 41.7\text{mm}$ would be big enough and should fit inside the available volume. But in this case friction forces are neglected and the maximum air pressure is used. In practice friction will occur between the piston and cylinder and between the piston rod and the seals in the end cap. Also variations of the weight of the Z-stage by adding or replacing components will give problems because there is no variation possible in the force exerted by the cylinder. In order to vary the pressure in the cylinder a regulator can be placed between the air pressure source and the cylinder, but one must take into account that such a regulator has a pressure loss of approximately 1 bar. The resulting available air pressure will then be 4.5 bar and a bigger piston area is needed to produce a force of 750 Newton.

The NANOMEFOS has been designed for high performance measuring of optical surfaces, therefore the probe must be positioned with an accuracy of $0.1 \mu\text{m}$ and too much friction must be avoided. The maximum friction can be calculated by Eq.(3.3) [3].

$$\delta = \frac{2|W|}{c} \rightarrow |W| = \frac{\delta * k_{mach}}{2} \quad (3.3)$$

Where δ is the accuracy of the machine, $|W|$ is the maximum friction force and c is the stiffness of the machine between the position frame and the force frame of the R-stage. For the NANOMEFOS $\delta = 1 * 10^{-7} \text{ m}$ and $c \approx 10^6 - 10^7 \text{ N/m}$. With use of Eq.(3.3) the maximum friction force $< 0.5 \text{ Newton}$.

3.2.2 Experiments with cylinders

In the previous paragraph the maximum friction force has been calculated. But the real friction force of pneumatic cylinders is still unknown. Therefore two cylinders are ordered from Festo (type DSNU-32-160). A section view is shown in Figure (3.2). These cylinders will be tested to acquire the friction force. The seals (2) between the piston rod (1) and the end caps (3) are removed to reduce friction and the cylinders become single acting cylinders because pressure cannot build up anymore between the piston (6) and the end cap (3) at the side of the piston rod. This is not a problem since the weight of the Z-stage will deliver the force to push the piston rod back into the cylinder. Unfortunately these cylinders cannot be disassembled because of the cylinder wall which is rolled into a slot in the end caps (4) which makes it impossible to remove extra seals from the piston (6).

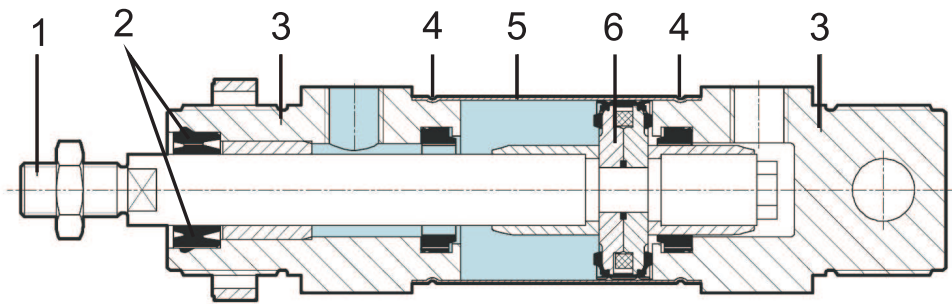

Figure 3.2: Section view of Festo cylinder (type DSNU-32-160)

Testing will be done with the setup shown in Figure (3.4). In this setup the cylinders are acting against each other. This will make it easier to build the setup because in this way the weight of the Z-stage is not needed. A disadvantage of this setup is the direction in which the cylinders are acting; while the piston rod of cylinder 1 is moving outwards, the piston rod of cylinder 2 is moving inwards or the other way around. In this way one cannot obtain information about the difference in friction between moving inwards and moving outwards. The first test is done in the way shown in Figure (3.4) where the cylinders (1) are connected to a tube (2). Slots (3) are made in axial direction in such way that a rod (4) can be placed through the tube perpendicular to it. The piston rods (5) with female thread at the ends are connected to each other with a piece of thread with the rod between the piston ends. Now the ends of the rod are outside the tube and can be moved together with the pistons. A certain force can be exerted on the rod via two strings (6) that are connected to the rod and a certain weight (7). By measuring the weight the force that acts on the rod can be calculated.

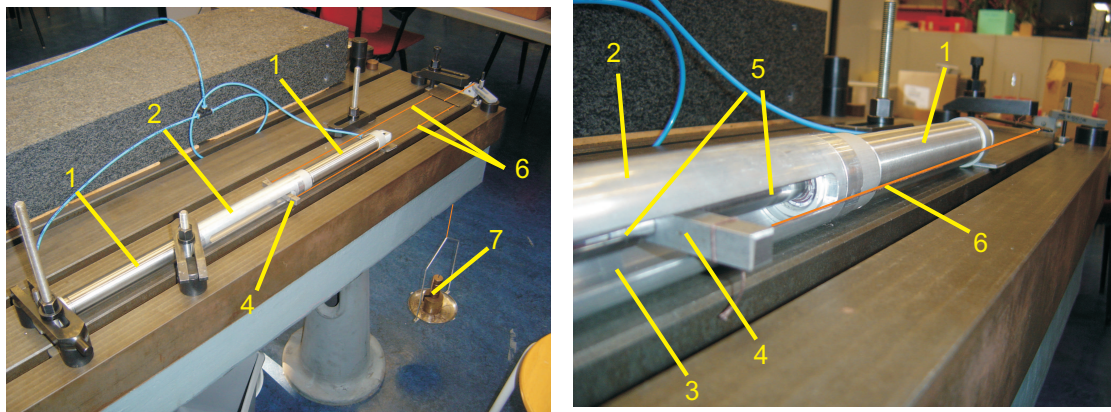

Figure 3.3: First test setup for pneumatic cylinders. (Festo DSNU-32-160)

It is important that the two piston rods and cylinders are placed in a straight line. Otherwise the piston rod will be pushed against the socket which is placed in the end cap or the piston can be pushed against the sidewall of the cylinder. This will cause undesired friction. Unfortunately, the cylinders in the test setup shown in Figure (3.4) are not well aligned. This can be seen in

the results shown at the left in Figure (3.5). During the test the dynamic friction is measured at different pressures. One can see that the friction becomes slightly higher with increasing pressure. The pressure needed in the NANOMEFOS is about 5.5 bar. When the rod between the piston rod ends is at the left half of the stroke the dynamic friction is higher (8 Newton at 5 bar) than when it is at the right half of the stroke (14 Newton at 5 bar). This is also the case when the cylinders are interchanged, so it is not due to the cylinders (the cylinders are not conical) but it is due to their alignment.

A new setup is designed to overcome this problem. (Figure (3.4)) In this setup the cylinders are placed the same as in the former setup, but now they are exactly aligned with each other without the interconnecting tube. This is done by leveling the cylinders on the table and at the backside they are connected to the table with hinges. The forces of the cylinders (the cylinders will be pushed away from each other) are now translated to the table instead of the interconnecting tube. The dynamic friction is measured the same way as in the first setup. The results are plotted at the right in Figure (3.5). It is obvious that the dynamic friction becomes higher at higher pressures, starting with 4 Newton at 1 bar to 8 Newton at 5 bar. There were no differences between the left or right side of the test setup anymore. Unfortunately these results do not satisfy the requirements and there are no other seals that can be removed because the cylinders cannot be disassembled.

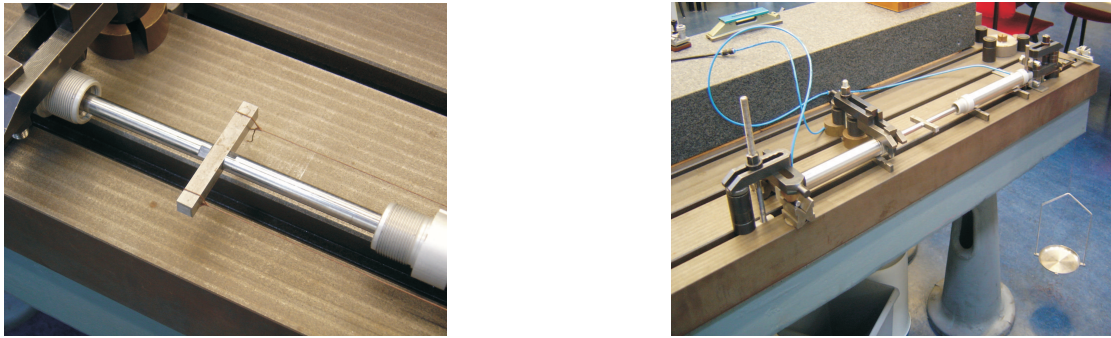

Figure 3.4: Second test setup for pneumatic cylinders. (Festo DSNU-32-160)

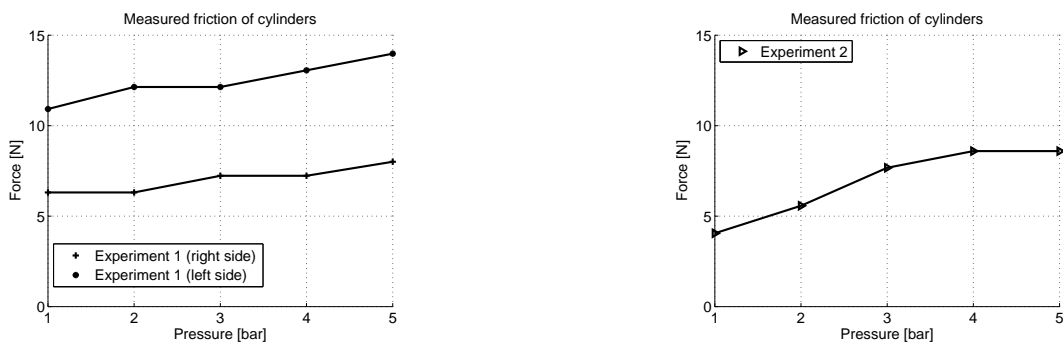

Figure 3.5: Results of test setup 1 (left) and test setup 2 (right) (Festo DSNU-32-160)

A new type of cylinders is ordered from Festo (type DNG-40-200) shown in Figure (3.6). These cylinders have a piston diameter of 40 mm and can be disassembled. The rods (10) between the end caps (4) and(9) can be removed to remove the end caps from the cylinder wall (5). Then the seal in the end cap (2) can be removed as well as the socket (3). From the piston one seal (6) and an extra ring (7) (used for guidance) are removed. Now every seal is removed except for the seal (8) that is needed to keep pressure at the right side of the piston.

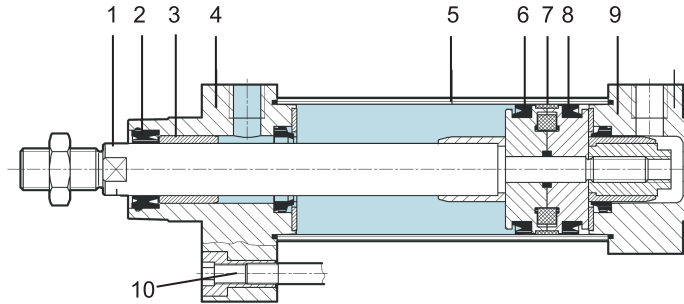

Figure 3.6: Section view of Festo cylinder (type DNG-40-200).

Less friction is expected in comparison to the other cylinders (Festo DSNU-32-160) because of the presence of just one seal per cylinder and no other parts that can cause friction. For the new cylinders another test setup has been designed and is shown in Figure (3.7). The piston rods are connected to each other by a connecting piece of bar stock. The rods can be screwed into the bar and become one rigid rod. In this situation the two rods do not buckle under their weight and rest in the cylinders with the two seals on the pistons. The tests are done in the same way as the tests with the other cylinders. But this time the dynamic friction as well as the static friction are measured during this test which is done with different pressures, starting with 1 bar and a maximum of 3 bar. Higher pressures are not needed because of the bigger diameter of the pistons (see Eq. (3.1)). The results from this experiment are shown in Figure (3.8). At a pressure of 3 bar (operating pressure) the dynamic friction is more than 10 Newton. Unfortunately these results are worse than the results from the other cylinders (DSNU-32-160) and are therefore against the expectations. The static friction is also plotted in Figure (3.8). It is important to know the static friction of the cylinders because that will be the force that must be delivered by the actuator to move the Z-stage from stand still. (The static friction of the other cylinders (DSNU-32-160) is not measured but is estimated lower than the cylinders (DNG-40-200))

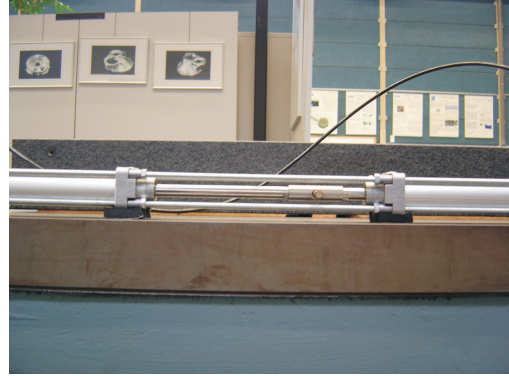

Figure 3.7: Second test setup for pneumatic cylinders. (Festo DNG-40-200)

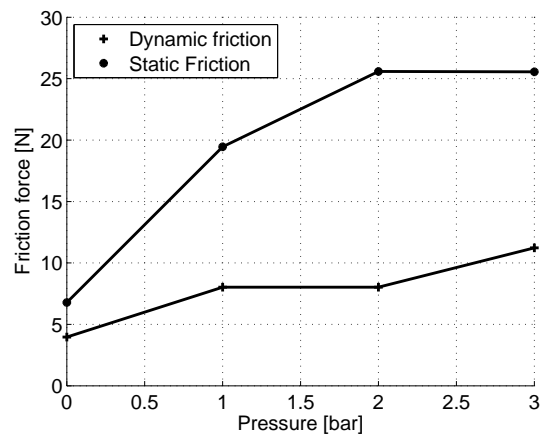

Figure 3.8: Results of test with cylinders (Festo DNG-40-200).

3.2.3 Use of cylinders in weight compensation

In spite of the results of the experiments, a weight compensation can be made with use of the Festo cylinders. However this will deteriorate the performance of the NANOMEFOS. Figure (3.9) shows a design for the weight compensation including Festo cylinders (1) (type DSNU-32-160). The cylinders are connected to part (2) which is attached to the R-stage with M-6 bolts (5). The piston rods are connected to a bridge (3) with a V-shaped slot which holds a sphere (4). The sphere will apply the force of the weight compensation to the force frame of the Z-stage. A second V-slot perpendicular to the first one is placed above the sphere, this V-slot is attached to the force frame of the Z-stage (not shown). These two V-slots and the sphere restrict only one degree of freedom: translation along the Z-axis. The other five degrees of freedom remain unrestricted.

Placing the cylinders close to each other is advantageous because of the moment of forces, due to different forces of the cylinders, which will be minimized. However, the cylinders used in this configuration are too big to fit under the force frame of the Z-stage. Therefore the cylinders are placed at a certain distance from each other with the force frame in the middle.

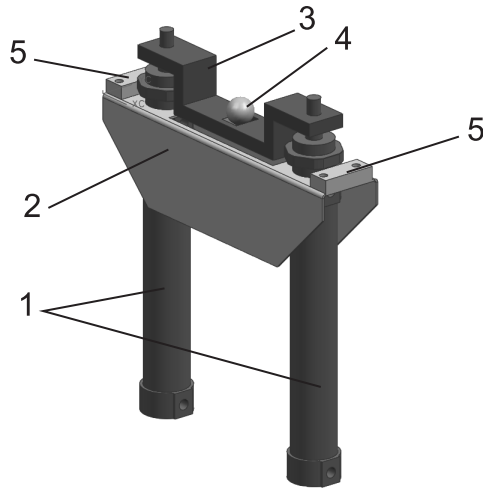

Figure 3.9: Design of weight compensation with Festo cylinders (type DSNU-32-160).

Chapter 4

Conclusion

The Z-stage including the probe has a weight of about 75 kg which has to be compensated. This weight compensation must fit into a limited volume inside the machine. For a solution with a leaf spring this volume is not big enough: the maximum calculated force is 14.2 Newton. Another solution could be the use of air pressure cylinders. Unfortunately the cylinders which are considered in this survey have a lot of friction. The static friction goes up to 25 Newton. The NANOMEFOS has a probe which has to be positioned with an accuracy of $0.1 \mu\text{m}$ and with the friction of the considered cylinders this accuracy cannot be achieved. Further research could be done with cylinders without seals (with air leakage past the pistons) or with seals of another kind. (e.g. O-ring with teflon coating)

Appendix A

Leaf spring

A.1 Elastic deformation

A very simple solution for a weight compensation can be a construction with a spring which can produce a constant force over the required distance. Major advantages of such a solution are the simplicity of the construction, the costs and the absence of external energy sources which can fail. Unfortunately it is very difficult to produce a constant force over a long distance with a spring.

A possible design may be a leaf spring shown in Figure (A.1) [3]. Two trapezium shaped leaf springs are bent towards each other, at points B they are attached to the side walls and at point A they are attached to each other. At point A a force is created which is constant over a certain distance due to the angle α . When point A is moved downwards more material must be bent and more energy will be stored in the material.

The force F_{spring} created by the spring can be calculated with Eq. (A.1).

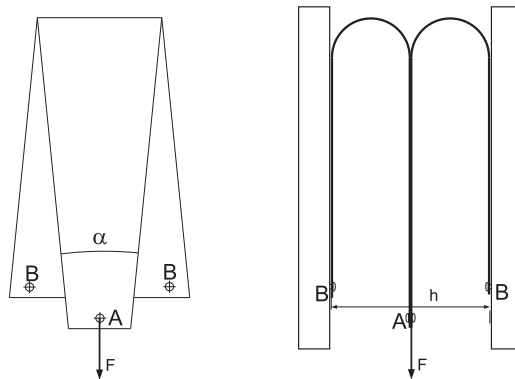

Figure A.1: Leaf spring that provides a constant force.

$$F_{spring} = \frac{\pi E t^3 \alpha}{12r} \tag{A.1}$$

Where E is the Youngs modulus, t is the thickness of the spring, α is the taper angle of the leaf

springs and R is the radius of the arc over which the leaf springs are bent. The force that has to be created is about 750 Newton. The spring can be oriented in the available volume in two ways: either h will be 50 mm or h will be 220 mm, the opposite concerns the maximum width of the spring. When $h = 0.050$ m the maximum radius will be $h/4 = 0.0125$ m. The width of the spring is then 0.220 m and is defined as: $b = b_0 + \alpha x$. When $b_0 = 0.01$ m and $x = 0.166 + 0.039 \approx 0.21$ m (maximum displacement + bent part of spring) then $\alpha = \frac{b-b_0}{x} = 1$ rad. The thickness t of the spring can be calculated with Eq. (A.2).

$$\sigma = \frac{Et}{2r} \rightarrow t = \frac{\sigma 2r}{E} \quad (\text{A.2})$$

Where σ is the maximum stress in the material which may not exceed the yield stress σ_0 . The yield stress for spring steel can be $965 * 10^6$ Pa. E is the Youngs modulus which is $2.1 * 10^{11}$ Pa. [2] The maximum thickness of the spring becomes $1.149 * 10^{-4}$ m and the maximum force becomes 6.67 Newton.

When $h = 0.22$ m, then $r = 0.22/4 = 0.055$ m and $t = \frac{965*10^6*2*0.055}{2.1*10^{11}} = 5.055 * 10^{-4}$ m. $x = 0.166 + 0.172 \approx 0.35$ m. The angle α is very small because of the narrow volume: $\alpha = \frac{0.05-0.01}{0.35} = 0.11$ rad. In this position the spring delivers a force of 14.2 Newton.

This kind of spring is not strong enough to deliver 750 Newton within the available volume.

Bibliography

- [1] R.Henselmans, L.A. Cacace, P.C.J.N. Rosielle, M.Steinbuch: Proceedings of the 7th euspen International Conference -Bremen - May 2007. Design and realization of a measurement machine for the universal non-contact measurement of large freeform optics with 30 nm uncertainty, 2007.
- [2] Key to Steel. www.key-to-steel.com.
- [3] P.C.J.N. Rosielle, E.A.G. Reker: Constructieprincipes 1, March 2002. Lecture note nr. 4007