

System identification in dynamic networks

Citation for published version (APA):

Hof, Van den, P. M. J., & Dankers, A. G. (2014). System identification in dynamic networks. In *Proceedings of the 21st International Symposium on Mathematical Theory of Networks and Systems (MTNS'14)*, 7-11 July 2014, Groningen, The Netherlands (pp. 557-558)

Document status and date:

Published: 01/01/2014

Document Version:

Publisher's PDF, also known as Version of Record (includes final page, issue and volume numbers)

Please check the document version of this publication:

- A submitted manuscript is the version of the article upon submission and before peer-review. There can be important differences between the submitted version and the official published version of record. People interested in the research are advised to contact the author for the final version of the publication, or visit the DOI to the publisher's website.
- The final author version and the galley proof are versions of the publication after peer review.
- The final published version features the final layout of the paper including the volume, issue and page numbers.

[Link to publication](#)

General rights

Copyright and moral rights for the publications made accessible in the public portal are retained by the authors and/or other copyright owners and it is a condition of accessing publications that users recognise and abide by the legal requirements associated with these rights.

- Users may download and print one copy of any publication from the public portal for the purpose of private study or research.
- You may not further distribute the material or use it for any profit-making activity or commercial gain
- You may freely distribute the URL identifying the publication in the public portal.

If the publication is distributed under the terms of Article 25fa of the Dutch Copyright Act, indicated by the "Taverne" license above, please follow below link for the End User Agreement:

www.tue.nl/taverne

Take down policy

If you believe that this document breaches copyright please contact us at:

openaccess@tue.nl

providing details and we will investigate your claim.

System Identification in Dynamic Networks

Paul M.J. Van den Hof and Arne G. Dankers

Abstract—Identification of particular dynamical transfers (modules) in a general dynamic network is addressed in the context of prediction error identification. Depending on the availability of measured signals, and the possible presence of (external) excitation signals, conditions are derived for the consistent estimation of prespecified modules. For this purpose existing closed-loop identification methods have been generalized to the situation of general dynamic networks with complex interconnection structures, including feedback. Topological conditions on the network can be verified by graph theoretical tools. The achieved results can be used as a basis for sensor and actuator placement schemes as well as for network structure identification problems.

EXTENDED ABSTRACT

In engineering, systems are becoming increasingly interconnected. Consider for instance the electrical power grid, telecommunication systems, and distributed control systems. To ensure the correct operation of each of these systems, accurate models of the system (or parts of the system) are required. Fortunately it is also becoming easier/possible to collect various types of data generated by these systems at different locations in the network. The question that we address in this paper is: under what conditions is it possible to consistently identify a particular subsystem that is embedded in a dynamic network? We assume that the interconnection structure of the network is known. We focus on local approaches in the sense that we only require locally available data to obtain an estimate of the subsystem of interest.

The network structure that we consider in this paper is built up of L nodes, related to L scalar *node signals* w_j , $j = 1, \dots, L$. Every node signal w_j can be written as:

$$w_j(t) = \sum_{k \in \mathcal{N}_j} G_{jk}^0(q)w_k(t) + r_j(t) + v_j(t) \quad (1)$$

with $G_{jk}^0(z)$ a proper rational transfer function, \mathcal{N}_j the set of indices of node signals w_k , $k \neq j$, for which $G_{jk}^0 \neq 0$; q^{-1} the delay operator $q^{-1}u(t) = u(t-1)$, v_j a possible *unmeasured disturbance* term being a realization of a stationary stochastic process with rational spectral density, and r_j a possible *external excitation signal*, available to and possibly designed by the user. A node signal is *measurable* in the sense that it can be measured using a measurement

device. Typically in engineering applications, a node signal is measured using a sensor. In practice it is not possible to exactly measure a signal. The measurement error will be referred to as *sensor noise*. The measurement of w_j is denoted

$$\tilde{w}_j(t) = w_j(t) + s_j(t)$$

where s_j is the sensor noise and is modelled as a stochastic process with rational power spectral density (it is not necessarily assumed to be white noise).

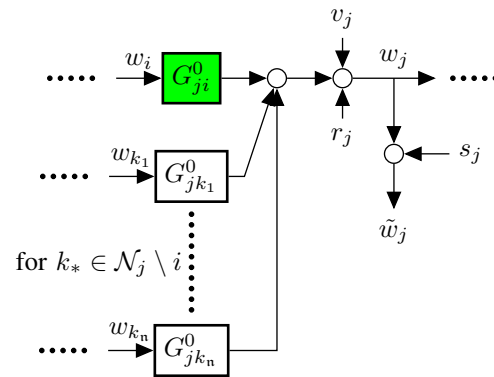

Fig. 1. Single node in a network structure.

A single node of the network is sketched in Figure 1, where the transfer function G_{ji}^0 has been separately indicated to focus on the transfer function that is supposed to be identified.

Multiple nodes can be interconnected resulting in a network as shown in Figure 2. In this figure node signals are placed inside the summation symbol (a circle) denoting that the output of the summation is the indicated node signal. For clarity, sensor noise has not been included in the figure. A possible objective could be to obtain a consistent estimate of the transfer function G_{32}^0 (denoted in green).

In a first stage of development, see e.g. [1], the problem has been considered of formulating conditions under which a particular module G_{ji}^0 can be estimated consistently on the basis of a subset of measured signals $\{w_k\}$. Typical prediction-error identification procedures that have been considered are direct and indirect (or two-stage) closed-loop identification schemes [2], [3]. In this stage all measurements are assumed to be taken noise free (i.e. the sensor noise is not present).

In a second stage of development, conditions have been presented that can be used to determine whether it is possible to identify a particular module given a particular set of

Paul Van den Hof is with the Department of Electrical Engineering, Eindhoven University of Technology, Eindhoven, The Netherlands p.m.j.vandenhof@tue.nl

Arne Dankers is with the Delft Center for Systems and Control, Delft University of Technology, Delft, The Netherlands a.g.dankers.tudelft.nl. His work is supported in part by the National Science and Engineering Research Council (NSERC) of Canada

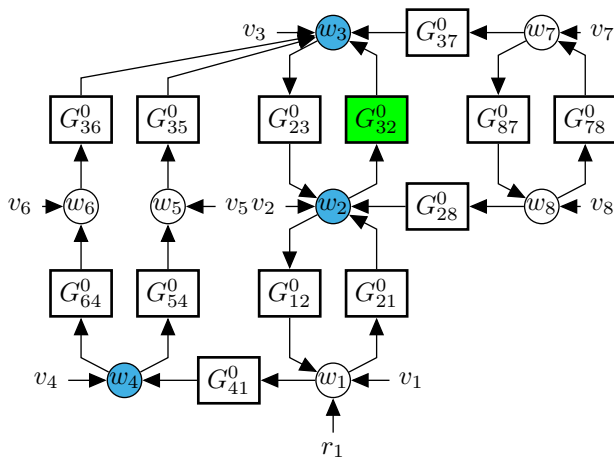

Fig. 2. Example of a dynamic network.

signals generated by the network [4], [5]. Again, in this stage the sensor noise is assumed to be zero. These results can e.g. be used to design sensor placement schemes. In addition the conditions can be used to determine whether it is possible to identify a particular module without using a particular measurement. This could be useful if a particular measurement is difficult or expensive to obtain, and so it would be preferred to avoid having to obtain it. The conditions can also be used to determine the smallest number of measurements required for consistent estimation of G_{ji}^0 . In the example network shown in Figure 2 it can be shown for instance that G_{32}^0 can be consistently identified using only measurements of w_3 , w_2 and w_4 (indicated in blue).

The derived conditions can be stated using graph theory. It is shown that the conditions define a separating set which isolates the output of the module of interest from the input of the module of interest.

In a third step, we deal with the presence of sensor noise on all the measured variables. This leads to problems of errors-in-variables identification in a network setting. The interesting phenomenon here is that in a network setting, unlike the situation in a single open- or closed-loop system, additional variables can be available that are correlated with the input and output signals of interest. It will be shown that this opens up new opportunities for dynamic network estimation schemes, where fruitful use can be made (and generalizations can be developed) of the classical instrumental variable schemes for identification, see e.g. [6].

In the proposed presentation the current developments in network identification will be summarized and highlighted.

REFERENCES

- [1] P. M. J. Van den Hof, A. G. Dankers, P. S. C. Heuberger, and X. Bombois, "Identification of dynamic models in complex networks with prediction error methods - basic methods for consistent module estimates," *Automatica*, vol. 49, no. 10, pp. 2994–3006, 2013.
- [2] U. Forssell and L. Ljung, "Closed-loop identification revisited," *Automatica*, vol. 35, no. 7, pp. 1215–1241, 1999.
- [3] P. M. J. Van den Hof, "Closed-loop issues in system identification," *Annual Reviews in Control*, vol. 22, pp. 173–186, 1998.

- [4] A. G. Dankers, P. M. J. Van den Hof, X. Bombois, and P. S. C. Heuberger, "Predictor input selection for two stage identification in dynamic networks," in *Proceedings of the European Control Conference 2013*, Zurich, Switzerland, July 2013, pp. 1422–1427.
- [5] A. G. Dankers, P. M. J. Van den Hof, and P. S. C. Heuberger, "Predictor input selection for direct identification in dynamic networks," in *Proceedings of the 52nd IEEE Conference on Decision and Control*, Florence, Italy, Dec. 2013, pp. 4541–4546.
- [6] M. Gilson and P. M. J. Van den Hof, "Instrumental variable methods for closed-loop system identification," *Automatica*, vol. 41, no. 2, pp. 241–249, 2005.