

Tilburg

Citation for published version (APA):

Curulli, G. I. (Ed.) (2010). *Tilburg*. (Kanaalzones B5; Vol. 2). Technische Universiteit Eindhoven.

Document status and date:

Published: 01/01/2010

Document Version:

Publisher's PDF, also known as Version of Record (includes final page, issue and volume numbers)

Please check the document version of this publication:

- A submitted manuscript is the version of the article upon submission and before peer-review. There can be important differences between the submitted version and the official published version of record. People interested in the research are advised to contact the author for the final version of the publication, or visit the DOI to the publisher's website.
- The final author version and the galley proof are versions of the publication after peer review.
- The final published version features the final layout of the paper including the volume, issue and page numbers.

[Link to publication](#)

General rights

Copyright and moral rights for the publications made accessible in the public portal are retained by the authors and/or other copyright owners and it is a condition of accessing publications that users recognise and abide by the legal requirements associated with these rights.

- Users may download and print one copy of any publication from the public portal for the purpose of private study or research.
- You may not further distribute the material or use it for any profit-making activity or commercial gain
- You may freely distribute the URL identifying the publication in the public portal.

If the publication is distributed under the terms of Article 25fa of the Dutch Copyright Act, indicated by the "Taverne" license above, please follow below link for the End User Agreement:

www.tue.nl/taverne

Take down policy

If you believe that this document breaches copyright please contact us at:

openaccess@tue.nl

providing details and we will investigate your claim.

- 1 's Hertogenbosch
- 2 **Tilburg**
- 3 Eindhoven
- 4 Helmond
- 5 Breda



2 TILBURG

KANAALZONES B5
2 TILBURG



layout by: alice cantore ana rodriguez lopez giulia orlandi katia kevork martijn maassen



INTERNATIONAL DESIGN STUDIO + MI / M2
2009 / 2010 INDUSTRIAL WATERFRONTS
TUTOR: I. CURULLI



INDEX

INTRODUCTION	1
PROGRAM	3
LOF DER TRAAGHEID	7
A PRAISE OF INERTIA	9

PROJECTS

1	DENSIFY - INTENSIFY	10
2	AXE EFFECT	20
3	PIUSHAVEN PATCHWORK	30
4	WATER STREET	40
5	WATERDROPS	48
6	EVOLVING NATURE	58
	FINAL PRESENTATION - EPILOGUE	68



INTRODUCTION

This book summarizes the design investigations of seventeen students during the process of collaboration between the Architecture Department at the Eindhoven University of Technology and the municipality of Tilburg. Goal of both institutions was the transformation of the Piushaven, a historical canal zone dated 1923.

This book shows a selection of the work generated by the design studio during one semester. The studio was formed by master students from the TU/e and international Erasmus students as part of their program at this university. Students worked in teams and cultural and language differences provided an excellent source that transcended national borders.

Several interrelated topics distinguished the studio. Firstly, the investigation on the issue of reuse of this historical site and its implications regarding the local memory and identity; secondly, the consideration of the goals outlined by the municipality; thirdly, the exploration of the relationship water and architecture and the meaning and use of water within the urban fabric; and lastly, the dialogue between our university and the municipality of Tilburg as a challenging opportunity to discuss a 'real' topic with a 'real' contact.

I consider the outcome of this studio the 'raw material' for the formulation of ambitions by the municipality. In fact, the creativity of students, free of limitations - such as money or political matters - has originated in new interpretations of the site, has offered alternative uses and has identified strategic locations for interventions. Furthermore, the feedback given to students by experts like the municipality's project managers, has contributed to more attentive projects that are conceptually stronger.

This work will not remain isolated. Actually, it has been developed within a framework of research that regards the transformation of the 'kanaalzones' of B5 or BrabantStad, which is formed by five cities within the North Brabant region. In fact, the cities of Helmond, Breda and Eindhoven have, like Tilburg and 's Hertogenbosch, their own former industrial canal zone and all of them encounter similar problems in the process of transforming the canals to new uses.

After the Zuid-Willemsvaart in 's Hertogenbosch, now the projects regarding the Piushaven in Tilburg have been the continuation of a research path. The future site to be investigated by the students participating in the upcoming design studio will be 'De Kade' in Eindhoven.

I would like to thank Thérèse Mol and Ludo Hermans, project managers of the Piushaven area from the municipality of Tilburg, for bringing a significant contribution to this studio through their passionate criticism and determination towards the students. Thanks also for providing the studio with base material on the site and for delineating the municipality's demands and, lastly, for guiding all of us in the discovery of the architectural beauties of the Piushaven.

My personal appreciation goes especially to all the students for their intense work, interest and enthusiasm for the studio. Their dedication, discovery and learning have made this publication worthwhile.

I truly hope you will enjoy reading about the projects they developed.

Irene Curulli

PROGRAM

Introduction

A waterfront is very often the face of a city. In fact seas, rivers and canals that face or cross urban structures, determine the morphology and character of a city. In many cases, shipping harbors or factory areas have made the waterfront distinctive, while propelling their liveliness, their atmosphere and the economy of the city.

Nowadays, such sites have increasingly lost their potential and without this bustle, cities are challenged to reveal their values and strength in these unused spaces. The voids left in many urban waterfronts attract the full range of demands on what the city is about and which are its needs. Acting in these areas becomes a sort of investigation of the “essence” of the city, while enhancing its spirit.

The approach towards transformation is diverse: the tendency is toward privatization of the waterfront, with commercial or residential use. Some interventions focus on leisure programs that entice tourism. The mixture of activities is the compromising answer to the struggling power of one particular use over the other. Yet does such a dynamic combination of activities put forward a waterfront’s long-term potential? Beyond the sum-up of activities, what makes a waterfront significant? Are former industrial sites and buildings assessed by their architectural and cultural values?

Objectives

The aim of the course is to investigate new strategies aimed at rehabilitating dismissed areas specifically located in the vicinity of a waterfront, thus making them desirable places to live in. This implies a careful reading of the site and the building’s history, recycling and processing and more, in order to develop a critical perspective on the concept of renewal design and its architectural and functional implications.

Project

The project design will concern a proposal for the development of a specific area among the five ‘Kanaalzones’ that characterize the Brabant cities (Helmond, ‘s Hertogenbosch, Eindhoven, Tilburg and Breda). These five cities are located in the southern area of The Netherlands, named North Brabant, and form the so-called B5. These cities strongly cooperate with each other so as to form a metropolitan area called BrabantStad. Infrastructures, cultural activities, design and innovations are some of the elements that promote the network among the five cities.

All five municipalities are longing for new design plans for their industrial waterfront areas. Some of them would like to focus on the revitalizations of specific portions of the former industrial canal-zones; others envision a transformation of the old buildings towards new uses; all of them need a mixed program able to rejuvenate these forgotten sites.

Refusing the ‘tabula rasa’ approach, the design studio will begin with a search for those in-built forces, patterns, materials that are embedded in the site. How to recognise these characteristics and differences? To design in this area does not only imply responding to a market demand. Moreover it is a challenging opportunity to experiment with water inventive programs and ways of living.

Site

The proposed site concerns the ‘Kanaalzone’ of Tilburg. This industrial area called the Puihaven was opened in 1923 with the goal of improving transportation to the industries of Tilburg, mainly textile factories. The construction of the canal zone had a great influence on the development of manufactories: new industrial buildings in different scale and architectural style were built.



In the 20's and 30's a large amount of goods went through the canal zone; freight ships delivered goods to Dordrecht, Utrecht and Amsterdam on a daily basis. In the 60's the closure of the site started. This was not related to the crisis of the textile industry, but to the changing economic structure of Tilburg. Furthermore, large companies moved to new industrial areas that offered more facilities, such as larger harbors and better connections with railway and road infrastructures. In 1983 the southern part of the Piushaven had been demolished, new houses were built on it, putting the meaning and identity of the remaining area at risk.

Luckily, the initiatives of local people have stopped the demolition plan and new ideas were promoted. The objective was to turn such location 'the new harbour' into the core of Tilburg. Nowadays, the municipality is dealing with different sections of the area and it is willing to convert the industrial structures that strongly characterize the Piushaven to new uses.

Two specific sites in the Piushaven have been the target of the design studio. All necessary basic material (digital drawings, maps,...) were provided to the students. A site visit of the area has taken place on the second week of the studio.

Method

Five interrelated phases have been completed during the design course.

Phase 1: warming-up activity.

The studio has begun with an exercise on the topic 'water infrastructures'. Students have investigated this subject through a short assignment.

A group of international Erasmus students and local students have formed the design studio at the start of the semester. This has proven to be an opportunity for an exchange of cultures and knowledge among the participants.

Phase 2: research.

Students have been required to research and analyse some 'industrial waterfronts' projects, either realised or not. The aim has been to become aware of similar designs as well as to develop sensitivity and criticism.

Phase 3: site impression and analysis.

Each student has been required, after the site visit, to express his or her impressions of the place by means of a model.

Analysis of the context and buildings has also been based on historical archive material and conventional parameters (distance, sizes, visual relationships,...). The aim has been to recognize multiple layers of the site through scientific reading and through the perceptive aspects that each individual has experienced.

Phase 4: design strategy for the area of design.

Students will elaborate a strategy for the waterfront site through the personal interpretation of the site's historical memory and through the critical analysis of demands from the municipality.

- The site is apparently 'mute': where to find its elements of interpretation and imagination?
- Which buildings or parts of them can be kept?
- What makes the waterfront significant?

Phase 5: design strategy and relation with water.

Special attention will be given to the appropriate use of materials and construction of the architectural spaces.

- Which inventive design can be proposed?
- Do on-site materials contribute to a new spatial form?

With the exception of the first assignment, students have worked in teams. Each group consisted of a maximum of three persons, with at least two different nationalities.



LOF DER TRAAGHEID

*Thérèse Mol and Ludo Hermans
project managers of the Piushaven area,
municipality of Tilburg*

In principe kan elke plek op de wereldbol een landingsplaats zijn voor ontwerp-opgaven. Maar er bestaat ook zoiets als thuis komen wanneer actuele vraagstukken en persoonlijke ambities van velen ingebed raken in de vruchtbare bodem van een gebied.

Het heeft geen zin te dromen over een Cape Canaveral in dicht stedelijk gebied, ook al brengt dat Mars dichterbij.

Het is moedig te blijven investeren in tolerante samenlevingen, ook al brengt dat ons niet altijd dichterbij elkaar.

Het is noodzakelijk een stedelijke leefwijze te ontwikkelen in overeenstemming met dat wat moeder aarde verdraagt, ook al zal dat streven blijvend geplaagd worden door eigenbelang.

De Piushaven als landingsplaats is zo 'n vruchtbare bodem. Het is een bescheiden stukje stedelijk landschap in Tilburg, waar sinds 1996 inspanningen worden geleverd om het gebied door transformaties te revitaliseren en met nieuwe ideeën over stedelijk leven aan de stad te binden.

Hoofdkenmerk van dat proces is traagheid, ondanks de haast van mensen. In die traagheid liggen de confrontaties tussen ambities, gedachten, ideeën en de (sociale, economische en ruimtelijke) realiteit van het gebied. Confrontaties die stof doen opwaaien. Confrontaties die bezinken en sporen naar de toekomst trekken.

Traagheid is voor de stedenbouw tegelijk proces en inhoud. Het is de geduldige toewijding en het stille luisteren naar al dat willen en gewin. Het is de hernomen lezing en anders begrijpen wat altijd al begrepen leek. Traagheid is de bron van de onuitputtelijke betekenis van een plek en hoe die met ons verweven raakt en geleidelijk (hoe dan ook) en uiteindelijk stolt tot een nooit vermoede realiteit. Het stof voor anderen.

In dat proces zien wij jullie enthousiaste denken en ontwerpen aan de Piushaven. Dank voor de bouwstenen voor nieuwe confrontaties en de nieuwe sporen. Dank om ons op te houden bij die dingen die wij dachten al begrepen te hebben en waarvoor wij nu moedig de handschoenen moeten opnemen.

Hartelijke groeten,
Thérèse en Ludo



A PRAISE OF INERTIA

*Thérèse Mol and Ludo Hermans
project managers of the Piushaven area,
municipality of Tilburg*

Basically every place on the face of earth can be a place to land design projects. Yet something like coming home exists: when actual problems and personal ambitions of many, become rooted in the fruitful soil of an area.

There is no point in dreaming of Cape Canaveral in a dense urban area, even though it might bring Mars closer.

It is valiant to keep investing in tolerant societies, even though it might not necessarily bring us closer together.

It is essential to develop a way of urban life that harmonizes with what mother earth can bear, even though that pursuit will be haunted continuously by self-interest.

The Piushaven as a place to land represents such fruitful soil. It is a modest part of urban landscape in the city of Tilburg, where since the year of 1996 efforts to revitalize the area through transformations have been undertaken, as well as efforts to bind the area to the city by new ideas about a way of urban life.

A primal characteristic of this process is inertia, despite the haste of people. Captured within this inertia are the confrontations between aspirations, considerations, ideas and the (social, economic and spatial) reality of the area. Confrontations that stir up matters. Confrontations that settle and become traces of the future.

Inertia in urban planning symbolizes both process and content. It stands for patient dedication and calmly listening to all that is desired and gained. It stands for taking up the thread of one's narrative and understanding differently what always seemed to be understood. Inertia is the very source of the inexhaustable significance of a place and how we get entangled with it and how it slowly (yet inevitably) clots in a reality never dreamt of. A matter for others.

We consider upon your enthusiastic thinking about and designing of the Piushaven in the light of this process. Gratitude for providing building stones for new confrontations and novel traces. Gratitude for delaying us with matters we felt to have understood already and for which we now valiantly have to accept the challenge.

Best regards,
Thérèse and Ludo



DENSIFY - INTENSIFY

martijn MAASSEN
michael HOCKETSTALLER
valeria TAORMINA

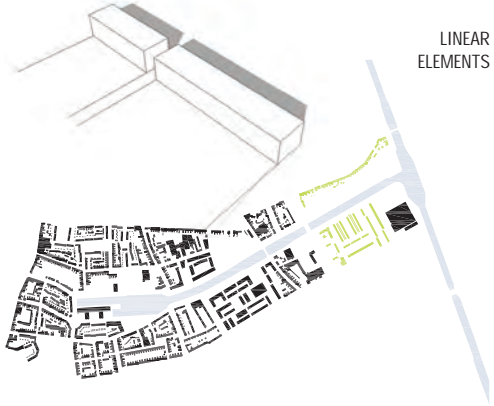
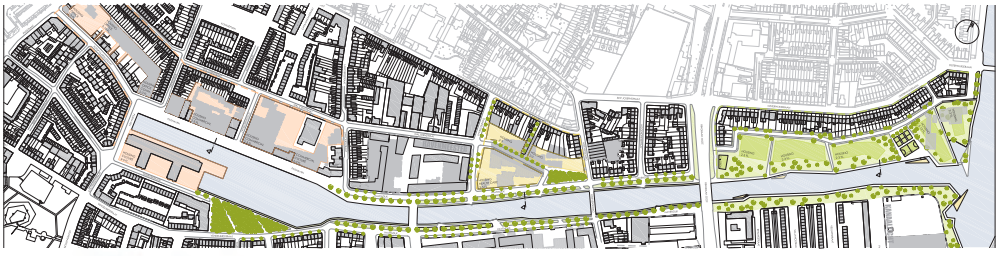

LINEAR ELEMENTS

The orientation of the canal zone - from the green outskirts at the east towards the grey centre of Tilburg - provides a means for creating different characters along the waterfront.

This character is defined not only through the appearance of the waterfront, but also through the dimensions of the building block and the quality of the space between facade and canal.

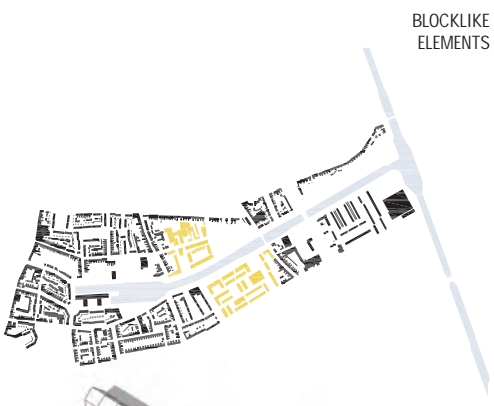

BLOCKLIKE ELEMENTS

The complete canal zone could function as a transversal connection between the natural outside of the city and the urban centre. This accelerating gradient from nature towards an urban environment is translated into an architecture that relates the newly built to the existing fabric and structure of the surrounding area. The three aspects mentioned above - the waterfront design, the typology of building block as well as the quality of the public space - are therefore architectural instruments to underline its position within the green to grey gradient.

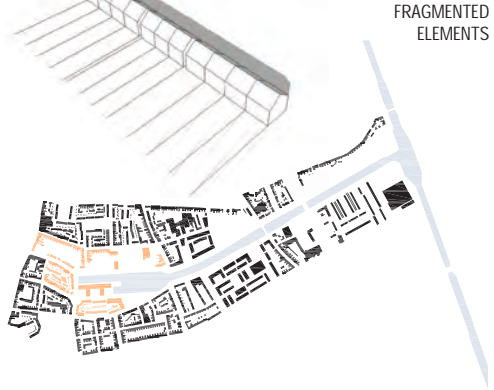

FRAGMENTED ELEMENTS

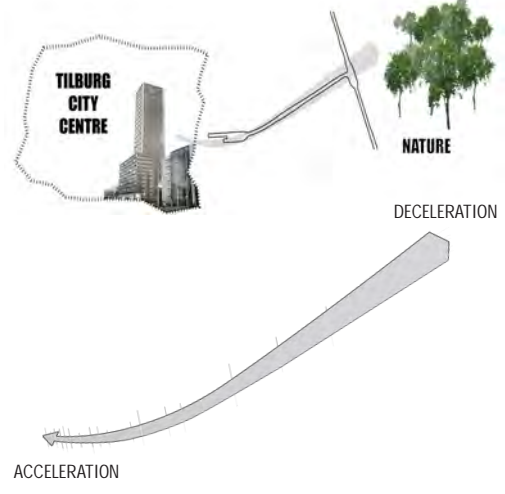

ACCELERATION

DECCELERATION



Building blocks at the east part of the canal are now characterized by linear elements. The newly planned residential area shows a similar linearity along the canal, that becomes intersected with green connections from the backroad towards the water edge. As a result, accessible green flows between the buildings, thereby intensifying the use of the space. It becomes an area in which people slow down, wander around, rest, stay, free in an open blue and green flood which has spread around the built mass. At certain points along the canal the water reaches in or land stretches out, thereby intensifying the interaction between people and the canal.



The middle part of the canal, now characterized by blocklike elements, is planned to be the joint between the density of the centre at the west and the intensity of the green at the east. Blocks of apartment buildings have been added to the area in order to accommodate more dwellings. These building blocks help to outline the decreasing depth of the public space provided along the waterfront. Where land and water collide, green becomes an ordinate system of tree lines.



Finally, the canal head at the left, now characterized by a fragmented grid, is planned to become an urban podium; a gathering of public functions without any green. The water edge and the line of facades become straight and clear-cut. Instead of removing buildings in order to create space for the functions to be added, these new volumes will be squeezed into existing pockets, stretched across the water or spread onto the street: creating a very intense experience of this dense area.

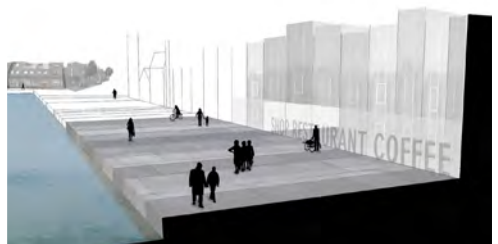

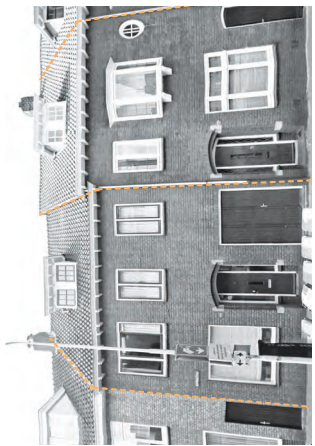
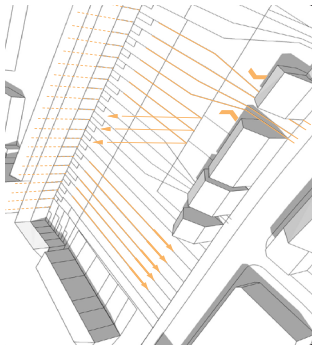
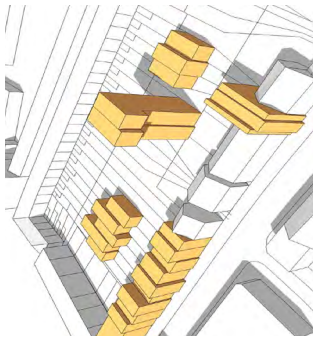

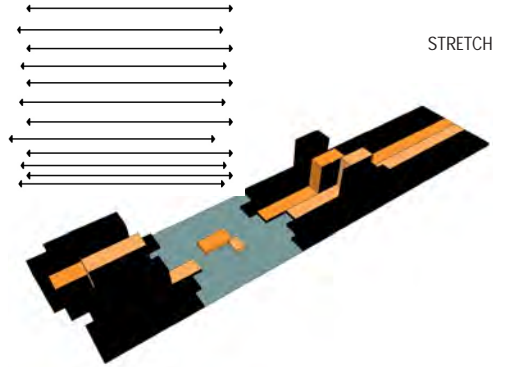
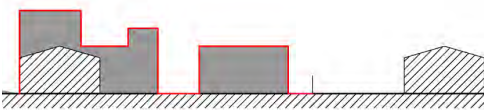
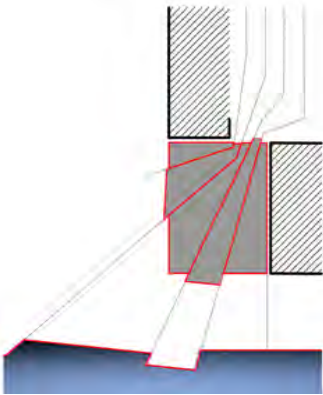
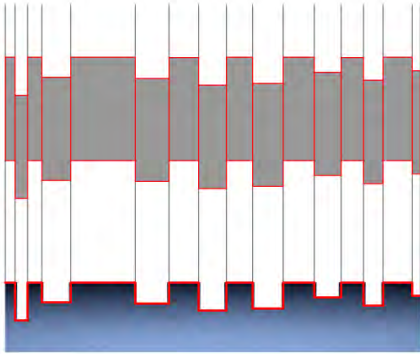
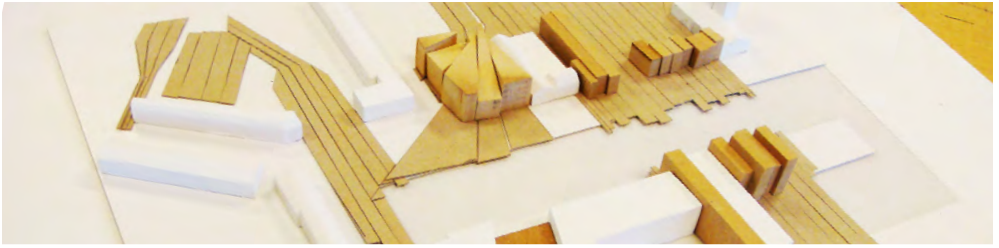

STRETCH

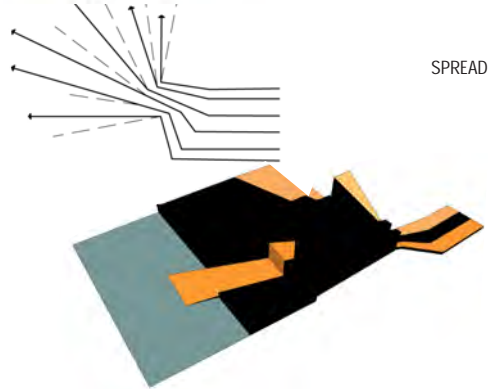

SPREAD

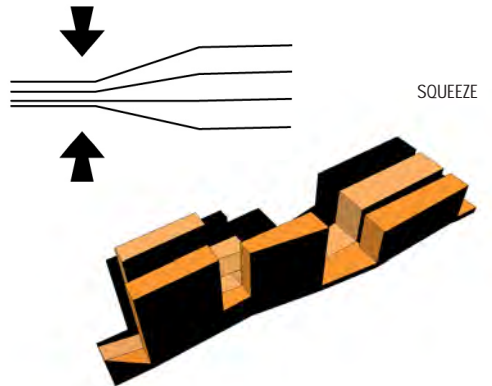

SQUEEZE

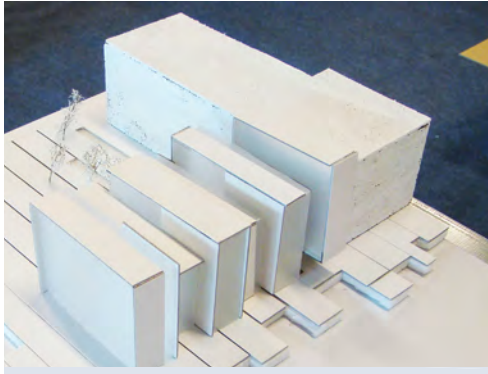
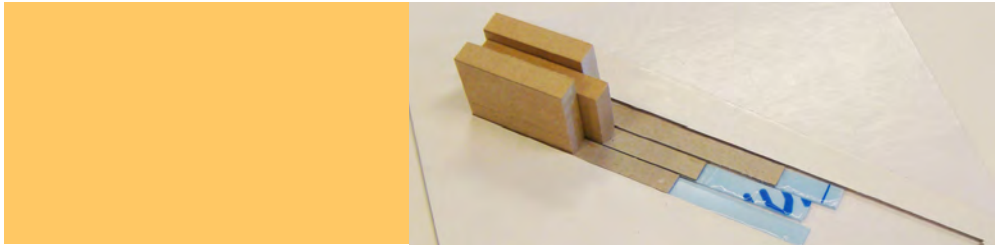

PROJECT STRETCH

GROUND FLOOR PLAN

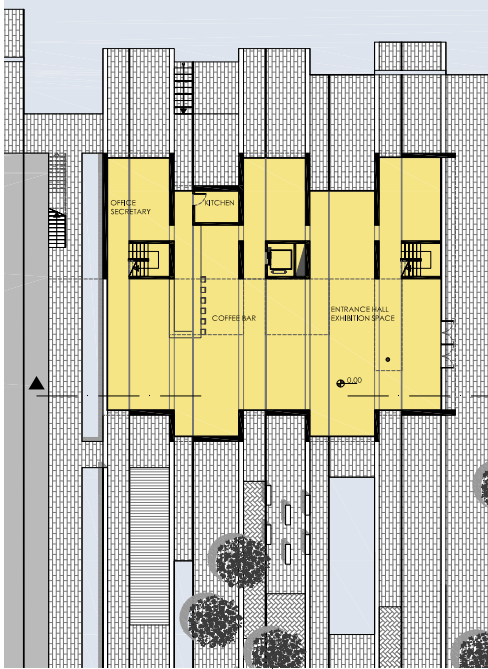

1st FLOOR PLAN

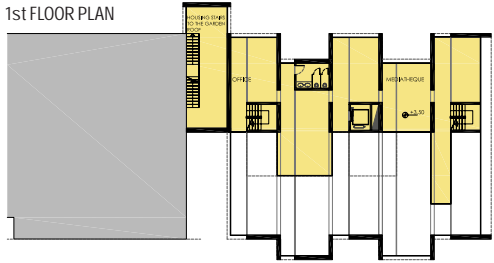

2nd FLOOR PLAN

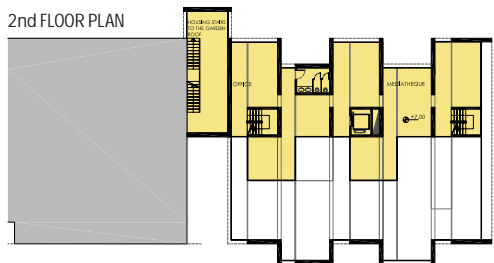

3rd FLOOR PLAN

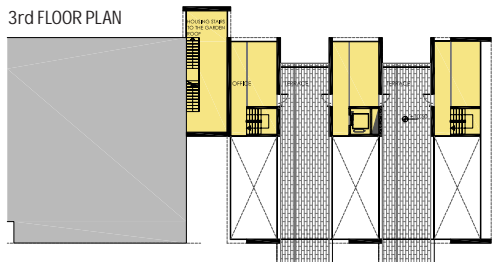

SECTION

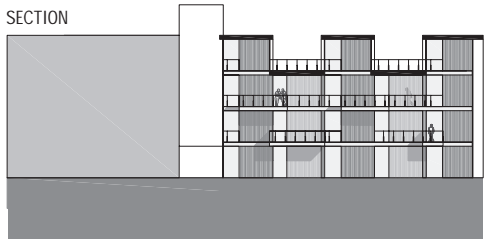

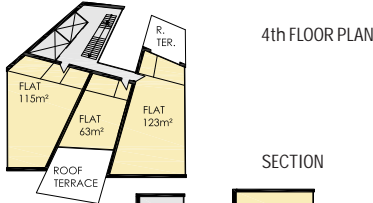
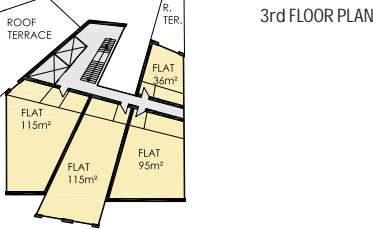
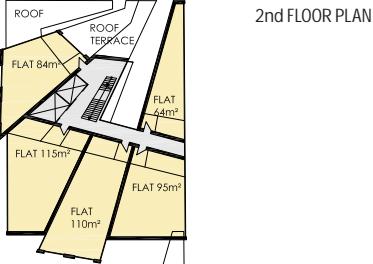
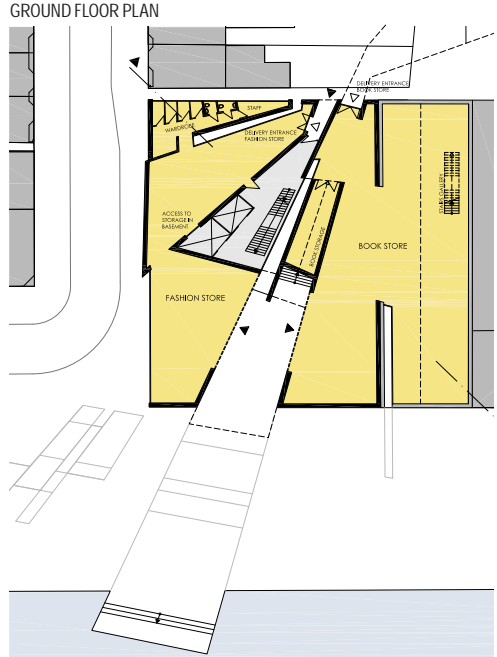
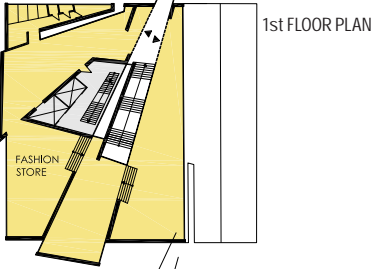
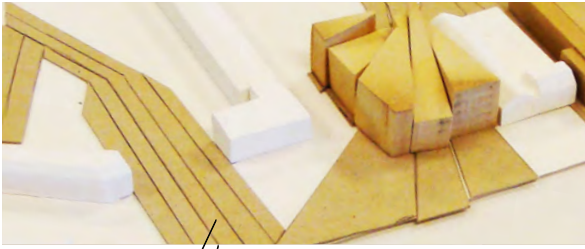

PROJECT SPREAD

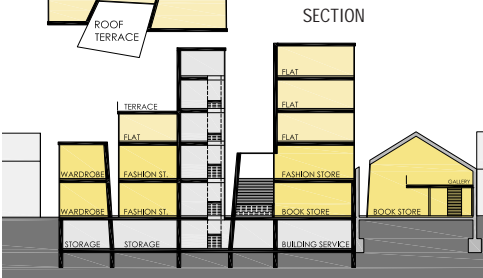

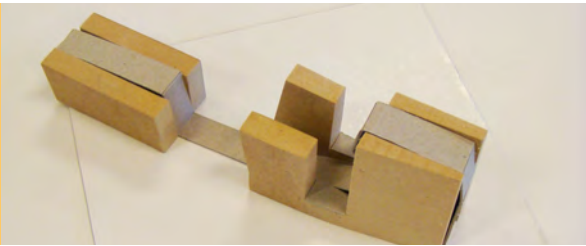

GROUND FLOOR PLAN

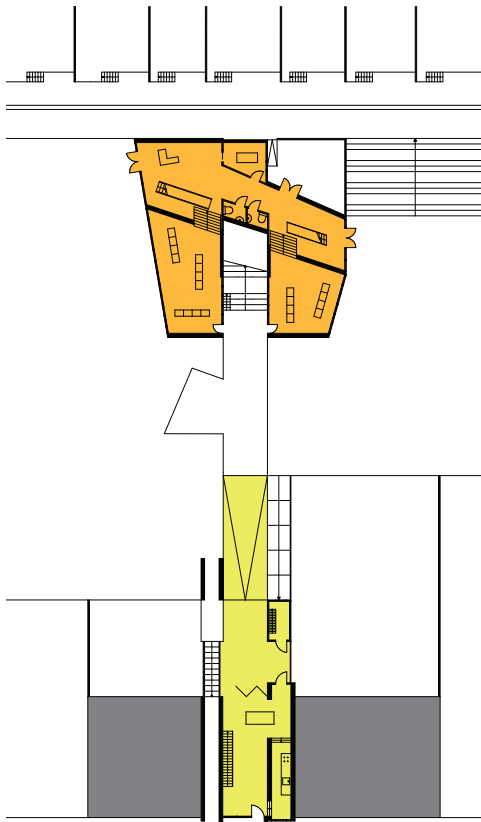

1st FLOOR PLAN

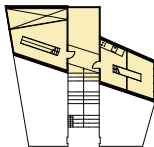

2nd FLOOR PLAN

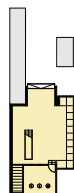
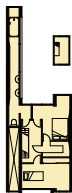
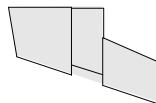

PROJECT SQUEEZE

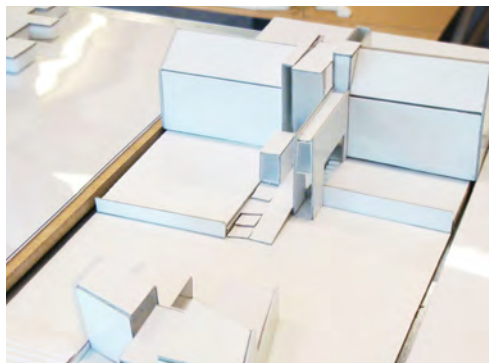

SECTION



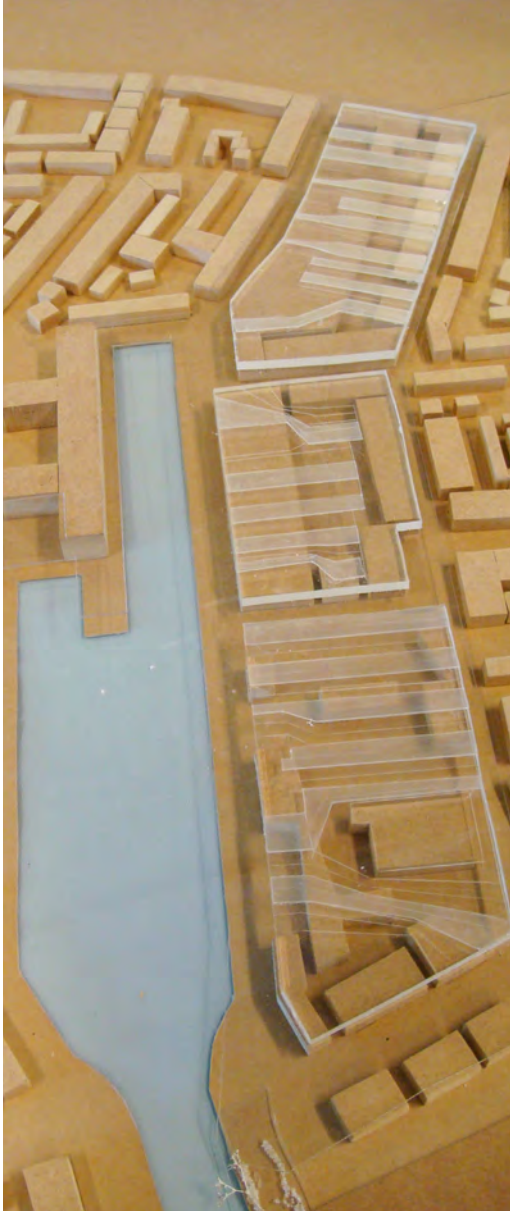



Attach eXpose Emphasize EFFECT

diana STANCIULESCU
katia KEVORK
milou PIETHAAN



Concept

A pedestrian route is created to bring the water towards the city centre and the city centre towards the water. This route is formed by a combination of architectural hints and functions. A good mix of functions will lead the public along the route and will create an all day lively environment.

The canal will function as a recreational area connecting the north and south banks. Various functions like bars, boat rentals and cultural events will bring the area to life. The barrier that the canal once was, is now transformed to a linking element through the new surrounding functions, a new bridge and platforms that prolong the easily accessible public space onto the water.

Drawing the people to the city centre and the canal zone is done by exposing and emphasizing elements along the route. These elements create and stimulate the exploration of the area. Through this, the route becomes an attractive element in itself.

One of the characteristics of the new masterplan is sieving. There is not one imposed route, but people are given the opportunity to explore the area surrounding the main route. Thus people get the chance to experience different spaces with unique characters.

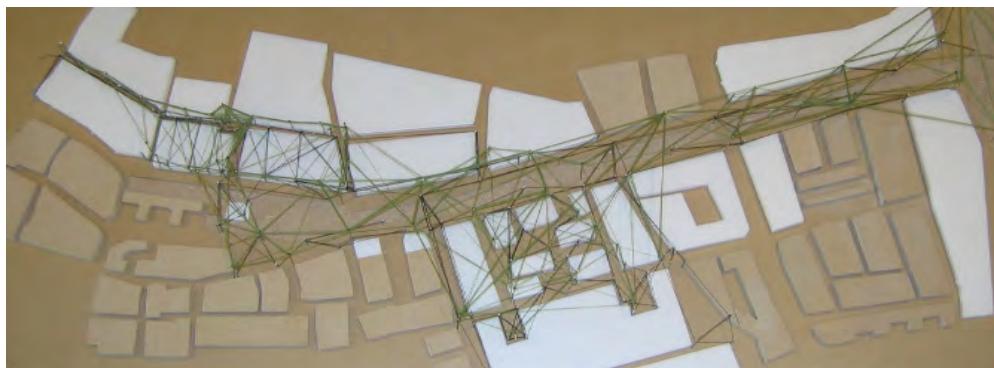

percolate:

The main route is a guide, but not the only way to discover the location. The area gives the opportunity to go and explore the site.



Attach:

A route through the area attaches different elements and brings coherence to this part of the city. Through this, the city centre is connected with the canal zone and the canal starts functioning as a public space which connects rather than divides.

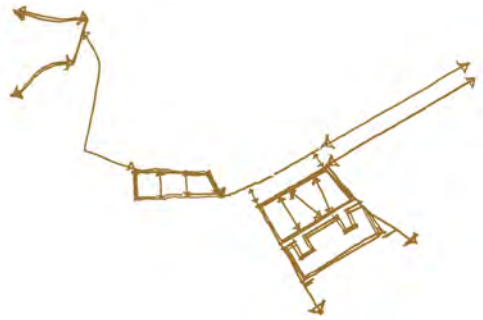

eXpose:

Hidden parts of the area that are valuable are exposed to a wider public, like the AaBe site and the inner character of some building blocks.



Emphasize:

Historic elements of the site are emphasized to maintain the genius loci of the area.



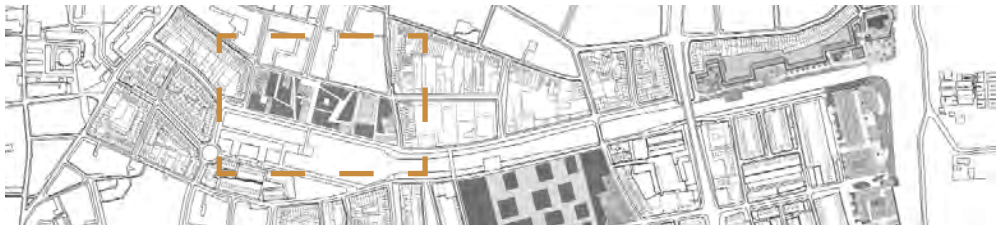

24

ROUTING

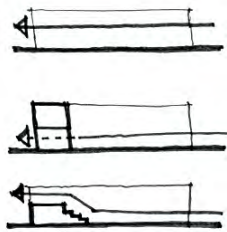

Built-Not built

CONNECTION WITH THE WATER — TRANSPARENCY



CANAL SIDE -
WATER -
PLATFORM
RELATIONSHIP



Heights

PLOT
SIZES

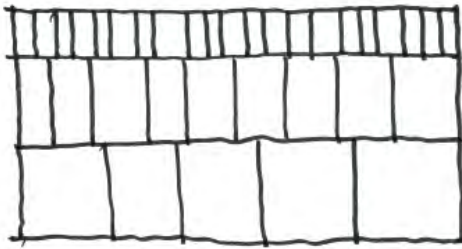

GROUND FLOOR
FUNCTIONS

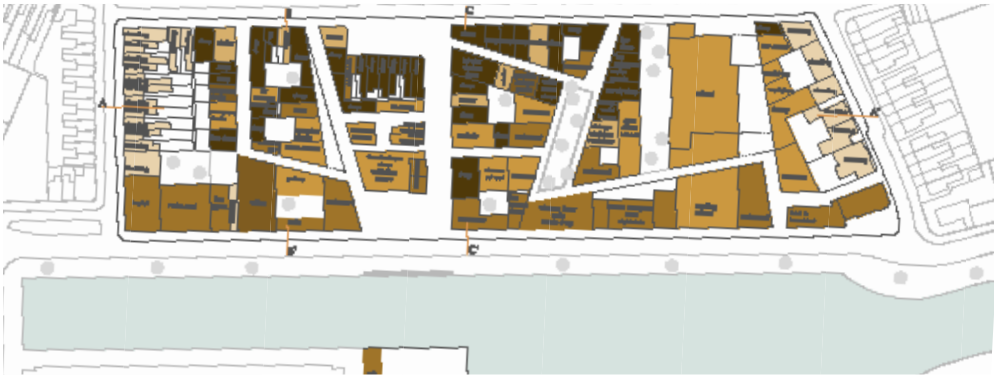

Site Plan

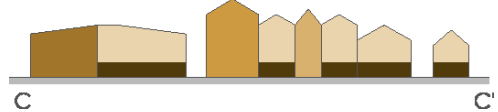
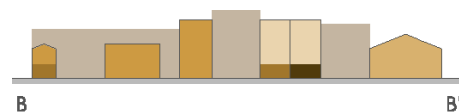

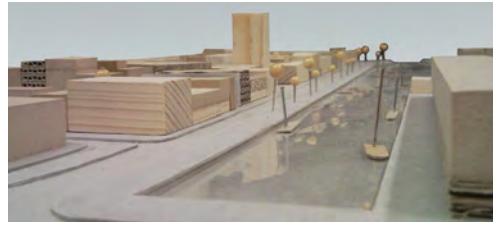

Havenpark

The area has a great potential and gives a lot of possibilities to intervene through architecture. This makes it a key point in the revitalization of the canal zone.

Some original buildings are preserved for historical as well as esthetic and functional value. In Havenpark there are only a few historic buildings, which have been emphasized in the new plan. The large amount of space that is suitable for new development in the area gives the opportunity to recreate this city part by applying the values of the new masterplan.

The building blocks maintain the original size but are cut through by alleys. These alleys expose the inside of the blocks to the outside public. The maze of alleys provides the opportunity to explore unique spaces. The alleys also provide a connection between the north side of the blocks and the canal side. This connection can be a visual or a physical one. The alleys and the exploring experience of the blocks will amount to a sieving character of the area. On the one side there is the centre, on the other the canal, and in between people get the opportunity to spread out and explore.

The area at the north side will be flooded with cultural functions, from shops and offices to horeca at the canal boulevard. At the east and west side existing dwellings have been preserved in the new plan. Throughout the area, parts higher than two floors have been dedicated to residential use. The mix of dwellings and public functions contribute to keeping the streets lively all day.

The changing character from north to south has the purpose of attracting and stimulating curiosity. This is done by adding galleries and specialist shops at the north side that are different in comparison to the functions at the centre. This difference becomes a reason to visit here, to enjoy bars and restaurants in such a relaxing place at the waterfront.

There is diversity as well as unity in the area: diversity in different heights, plot sizes and functions, unity in the range materials, continuity of the front and scale.



The square

The square is representative for the Havenpark masterplan and has therefore been chosen to develop in further detail. The square has a subtle connection with the canal through the transparent part of the cinema. The square is surrounded by old buildings as well as new designs, making it a mix of architectural styles. To unify the square, the basic material for the elevations is set to be bricks in different shades of brown. Pitched roofs are applied on part of the buildings, referring to the surrounding areas of the Piushaven.

The atmosphere of the square is also defined by the functions surrounding it. There is a lot of variety within these functions, with the dwellings being mainly positioned at the upper building layers.

The design of the square results in an urban lounge area, with relatively open architecture on the square-facing elevations and relatively closed architecture in the alleys leading towards the square to encourage movement towards the square.

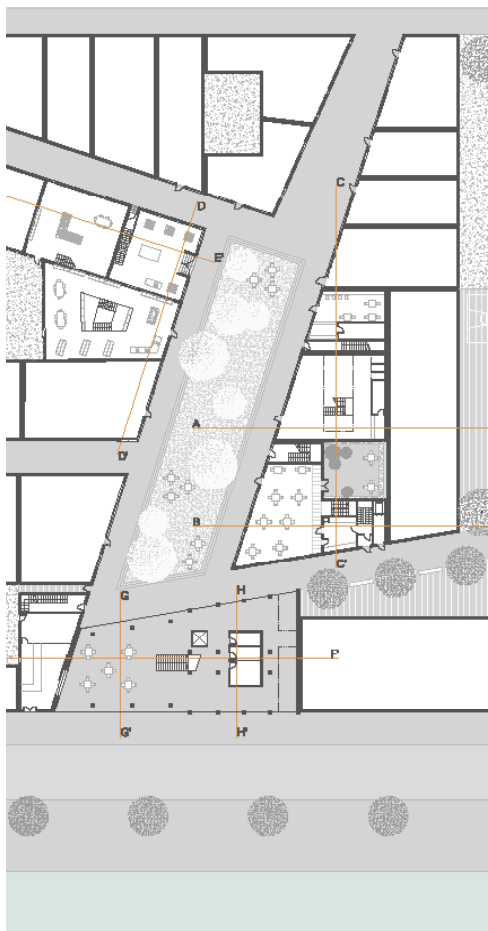



Facade Elevation Square: East Side

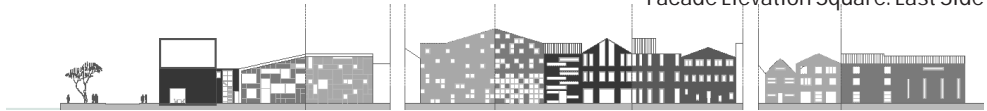

Facade Elevation Square: West Side



Facade Elevation: Canal Front

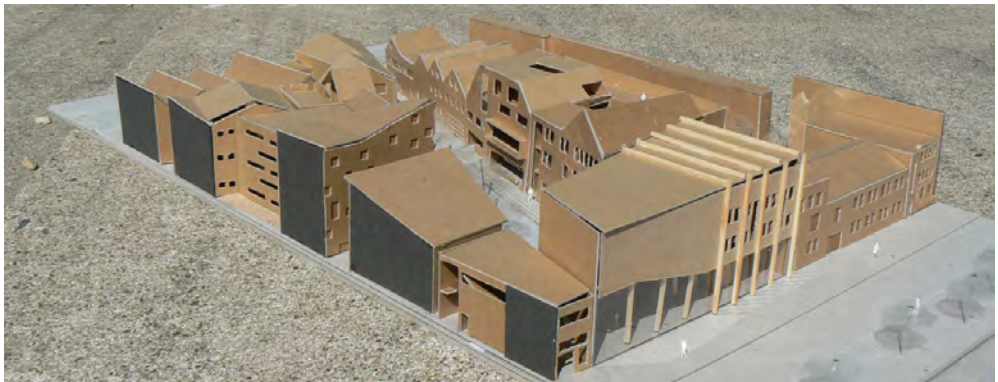

Cinema

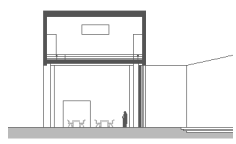
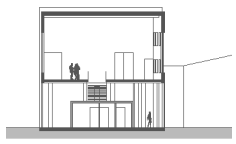
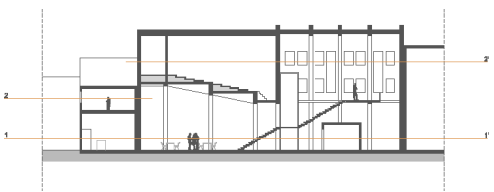
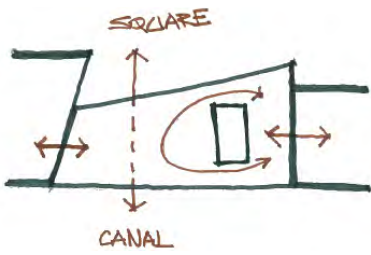

Vintage Clothing Workshop

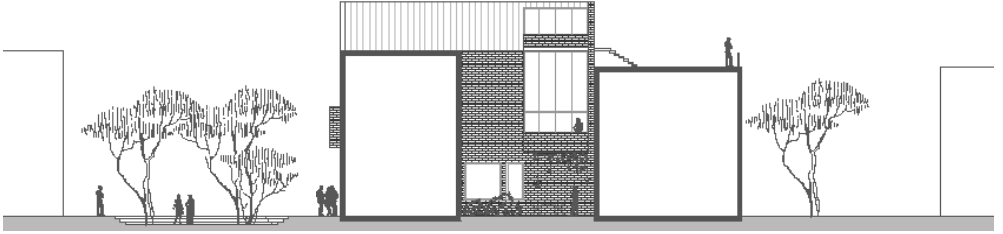
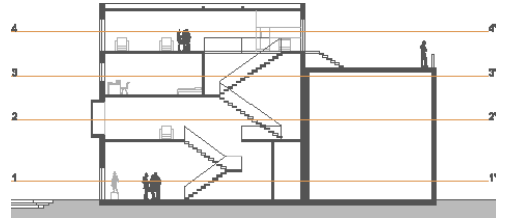

Wine Cellar Shop

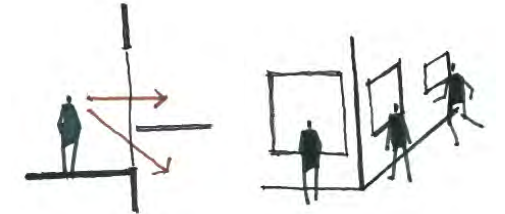
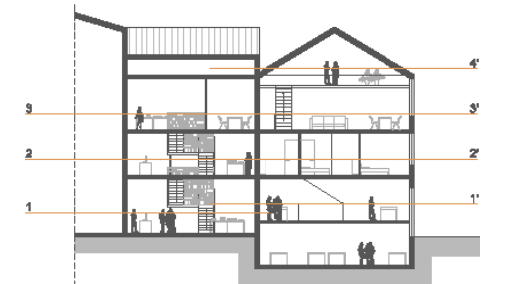
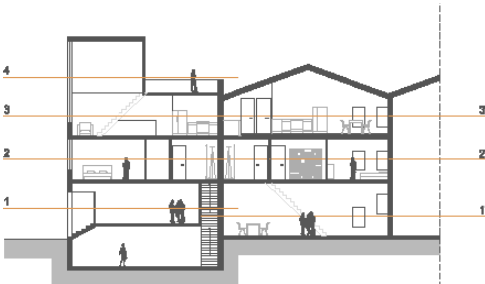



PIUSHAVEN PATCHWORK

alice CANTORE
debora TEXEIRA CHAVES
dik DE VOOGD

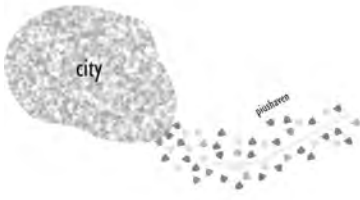

FILLING THE
EMPTINESS

The Piushaven area in Tilburg is characterized both by big empty spaces and abandoned areas from an old industrial identity, and by a small compact pattern made by residential and commercial buildings.

PLAYING WITH
THE SIGNS OF
THE EXISTING

The canal is a precious element in the area, yet it is considered more like a barrier. Including the canal in the urban strategy means to use it to link diversities in order to create one identity of the Piushaven.

The urban strategy consists in sewing together different left-over pieces of the city that characterize the existing waterfront in a larger design, like a patchwork.

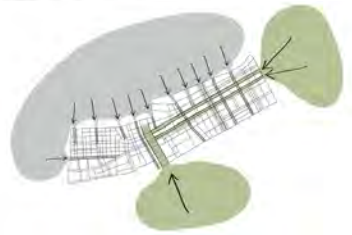
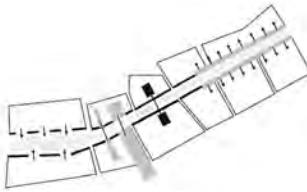

CREATING
ONE IDENTITY
WITH *MIXITE*

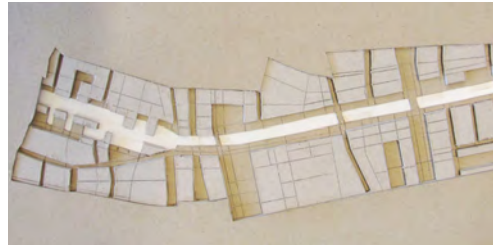

THE CANAL AS
LINK BETWEEN
DIVERSITIES

Each piece of the patchwork represents one area defined by city lines - canal, districts, green, roads lines. It does not represent a real masterplan, rather it gives guidelines about how to act in the complete Piushaven area.

LINE OF THE
STRATEGY:
THE GREEN

The patchwork can be read using the matrix, the colors represent any physical treatments of the space, whereas the textures represent the usage of the area. In this way one can create even more different combinations and mixité.

LINE OF THE
STRATEGY:
THE ROAD-NET

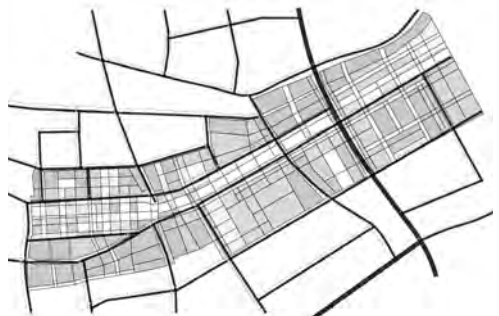

The connections between water and edge and mutual edges are linked to the identity of each area, in order to get a diverse waterfront. The experience of walking along the new waterfront becomes a surprise in every patchwork piece.

The urban character enters the area through its streets, from the centre of the city to the canal and across. The green character enters the Piushaven from the south, where an existing park is situated, and from the east, more agricultural, shaped by the lines of the city.

The new traffic net creates two directions of movement in order to get a new pedestrian area at the water.

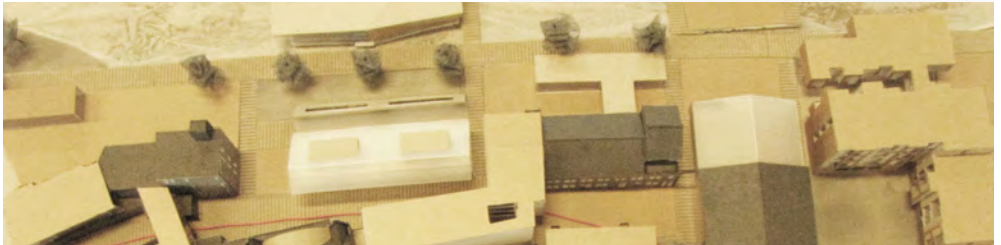

The first line along the canal is allotted to pedestrian and bike traffic, hence it represents a slow fluxus. The transversal line crosses the canal as a north-south axis and represents a fast fluxus. The result is a more vivid Piushaven, attractive to different needs. The combination of these lines create the strategy of the patchwork.

The old buildings are characterized by different shapes, colors and materials, but altogether they contribute to the image of the waterfront.

The strategy consists both in filling and densifying the empty spaces and making the new buildings match the old pattern of the area.

On an urban scale level, this strategy aims to fill the empty spaces, playing with the structure of the old existing buildings and their mixed identity and functions.





PATCHWORK MATRIX

AREAS TREATMENT	FILTER TREATMENT									
	NO LINE COLOR	NO LINE DASH	THICK LINE	NO SHARP	NO FINISH	NO NETS & B	NO SHARP	NO SHARP	NO SHARP	NO SHARP
WATER	[Pattern]	[Pattern]	[Pattern]	[Pattern]	[Pattern]	[Pattern]	[Pattern]	[Pattern]	[Pattern]	[Pattern]
EXISTENTIAL	[Pattern]	[Pattern]	[Pattern]	[Pattern]	[Pattern]	[Pattern]	[Pattern]	[Pattern]	[Pattern]	[Pattern]
BOUNDING WATER	[Pattern]	[Pattern]	[Pattern]	[Pattern]	[Pattern]	[Pattern]	[Pattern]	[Pattern]	[Pattern]	[Pattern]
KEEPING THE FACILITY	[Pattern]	[Pattern]	[Pattern]	[Pattern]	[Pattern]	[Pattern]	[Pattern]	[Pattern]	[Pattern]	[Pattern]
NEW WINDOWS	[Pattern]	[Pattern]	[Pattern]	[Pattern]	[Pattern]	[Pattern]	[Pattern]	[Pattern]	[Pattern]	[Pattern]
OLD AND NEW	[Pattern]	[Pattern]	[Pattern]	[Pattern]	[Pattern]	[Pattern]	[Pattern]	[Pattern]	[Pattern]	[Pattern]
FRONT FACILITY	[Pattern]	[Pattern]	[Pattern]	[Pattern]	[Pattern]	[Pattern]	[Pattern]	[Pattern]	[Pattern]	[Pattern]
NEW GREEN	[Pattern]	[Pattern]	[Pattern]	[Pattern]	[Pattern]	[Pattern]	[Pattern]	[Pattern]	[Pattern]	[Pattern]
EXISTING GREEN	[Pattern]	[Pattern]	[Pattern]	[Pattern]	[Pattern]	[Pattern]	[Pattern]	[Pattern]	[Pattern]	[Pattern]

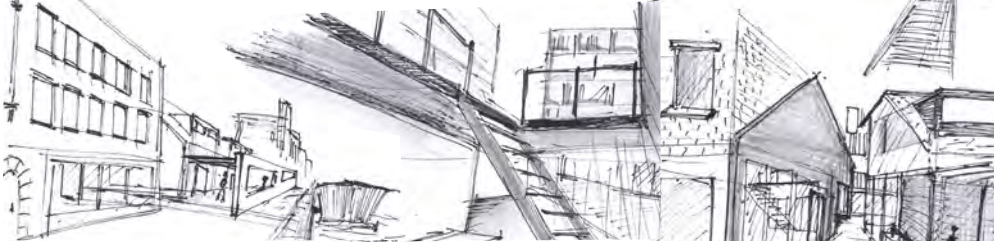
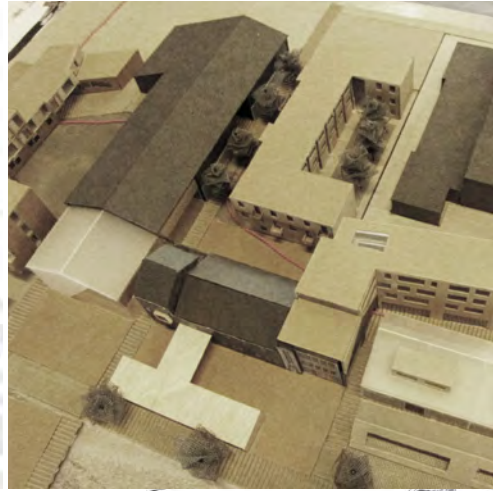

DIFFERENT INDIVIDUALITIES IN ORDER TO CREATE ONE IDENTITY



GROUND FLOOR PLAN

1. THE STUDENT RESIDENCE



ELEVATION

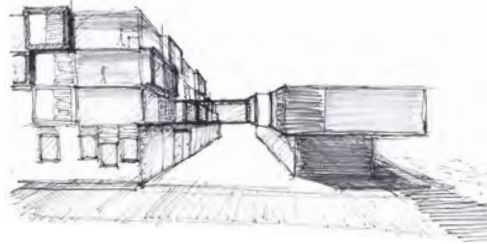

The patchwork in the Piushaven can be understood from both the treatment of the ground as well as the architecture. Different materials define the quality and the use of each space: wooden paths create space to move that are also links between the city and the canal. The areas in front of each building create spaces to enjoy and to stay related with the function of the building in front. In this way, crossing the Piushaven waterfront makes people experience the different patches.

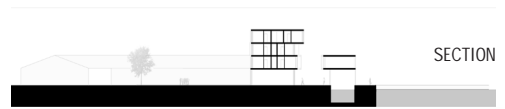

SECTION

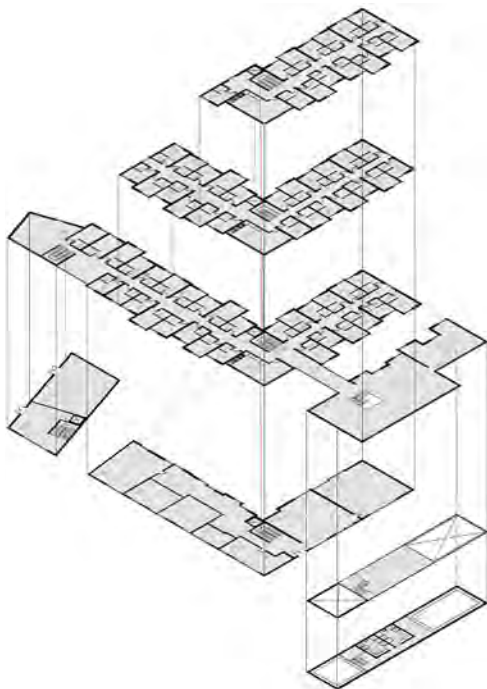
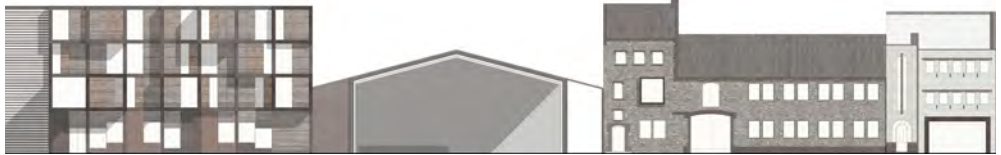

FLOOR PLANS

2. THE SLIDING THEATRE

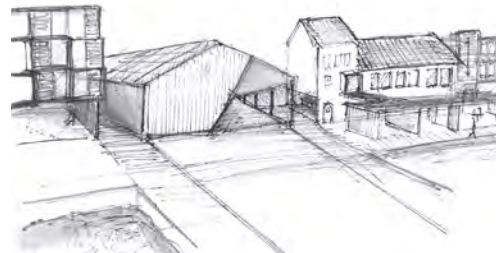

3. THE *DUTCH HOUSE*



ELEVATION



DIAGRAMS

A	A
A	B
B	B



4. THE RESTAURANT / CAFÉ

FLOOR PLANS

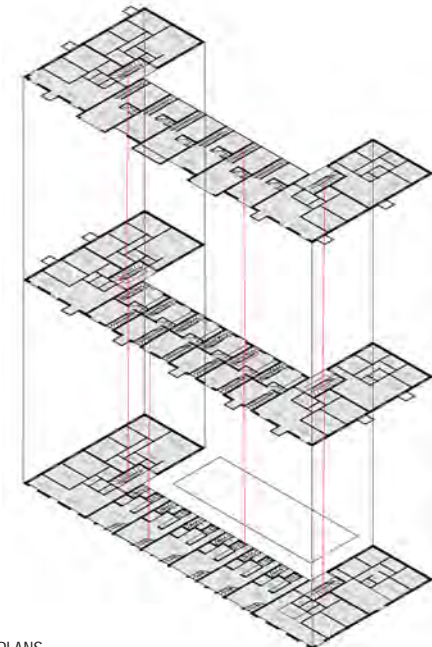
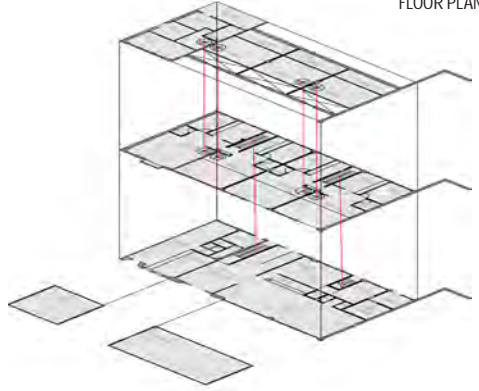

FLOOR PLANS

From the architectural point of view, each building belongs to a patch. Buildings in different patches have different shapes, already a very common characteristic of the old Piushaven. Different shapes can be kept together by the canal and the patchwork. The materials used are wood, steel and glass, and are used following the rules of guiding the view.

SECTION

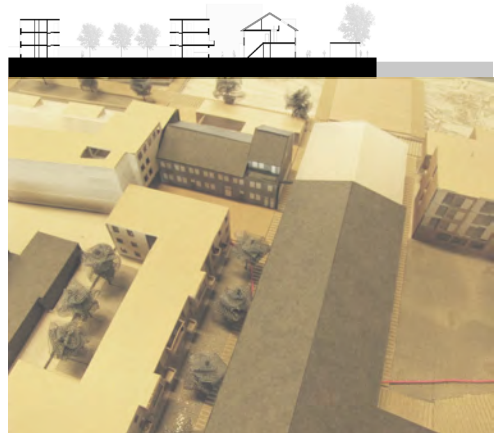

5. THE TRANSPARENT SHOP

6. THE "KNOT" BUILDING

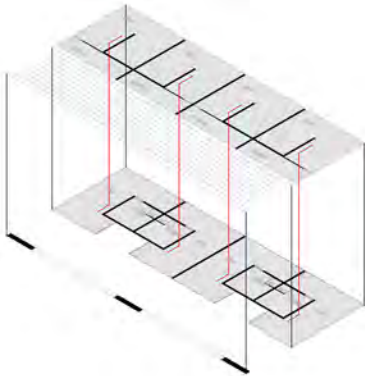

FLOOR PLANS

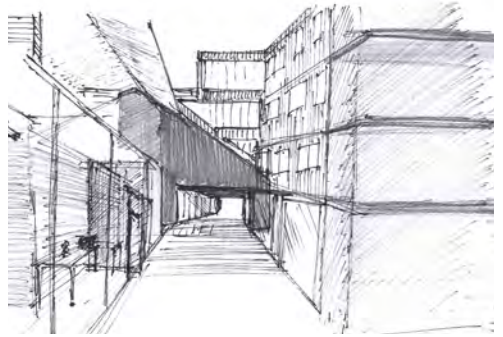

SKETCH

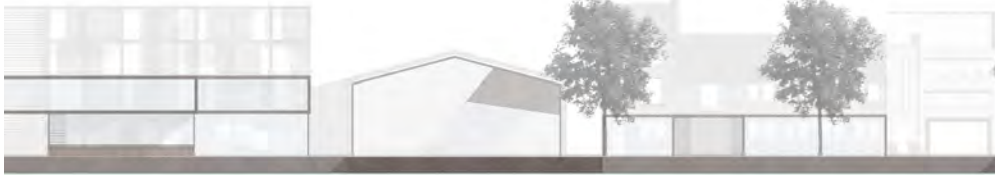

DIAGRAM

FLOOR PLANS

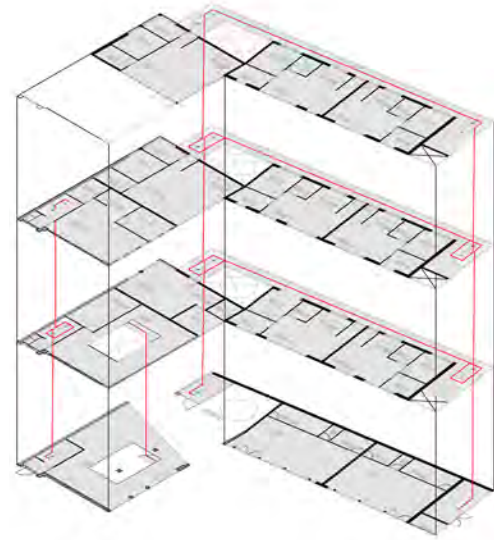
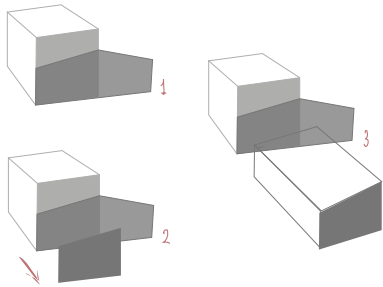

SECTION



7. THE DESIGN SCHOOL

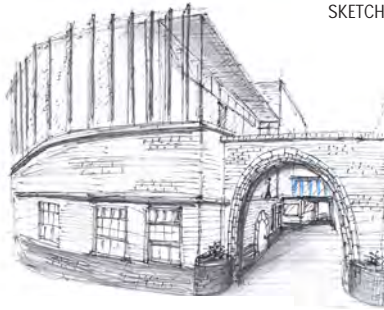

SKETCH



SECTION



SKETCH



FLOOR PLANS

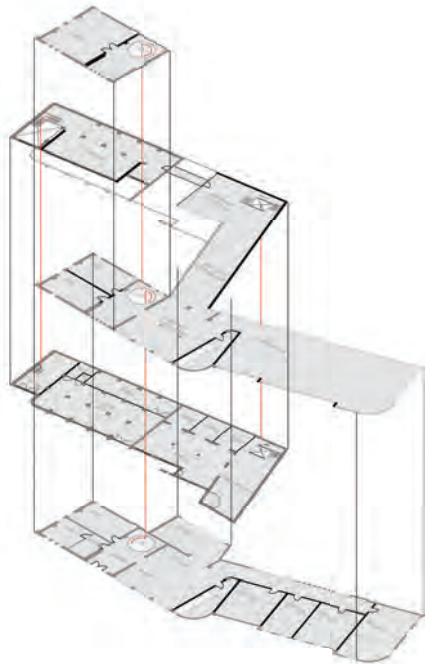
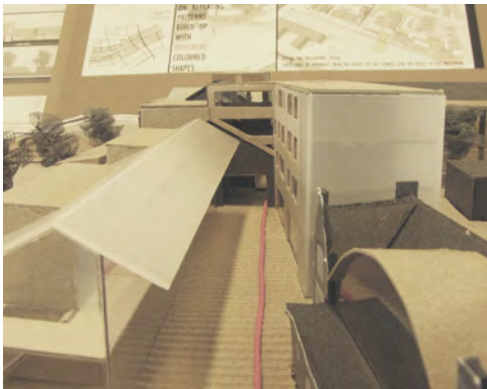



WATER STREET

ana RODRIGUEZ
frank RYCZER
willeke KLOMP

STRATEGY



The canal zone of Tilburg used to be an industrial area. Industrial activity was the very reason the canal was dug. With the loss of industry, the Piushaven has lost interest, the significance of water inside the city seems to lack.

Under influence of our water street strategy the Piushaven will bloom once again, by adding new functions and experiences that use the water as central theme. The intention of the project is to make Tilburg unique in a broader sense, a city with a strong identity. The Piushaven has the potential to become the destination for business, family life, tourism, culture and education.

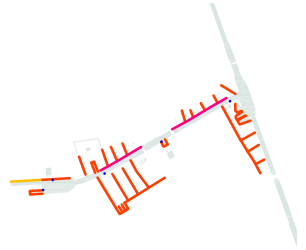
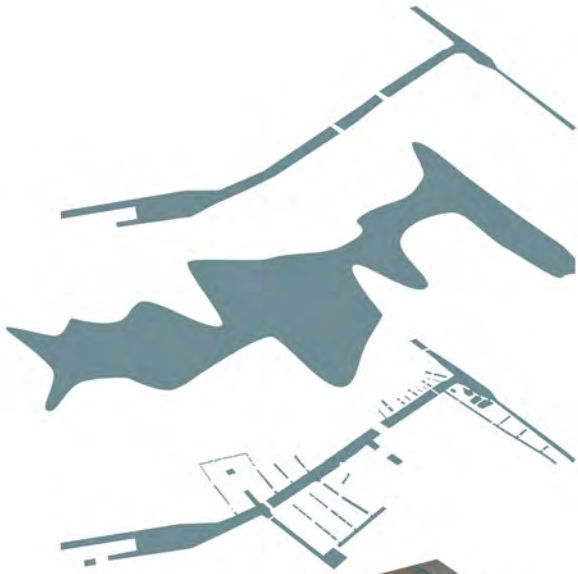

KIND OF WATER SPACES



MAIN ROADS

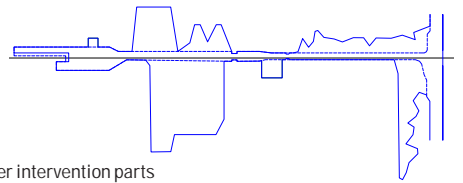
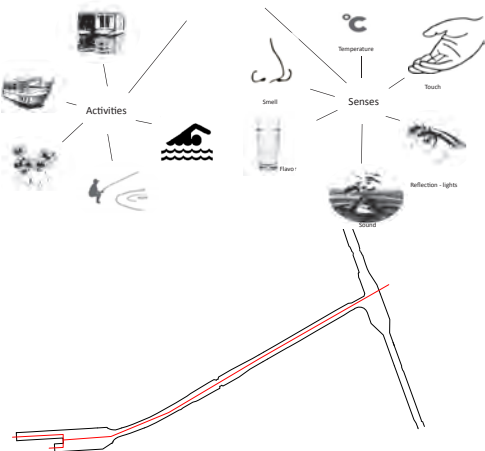

water intervention parts

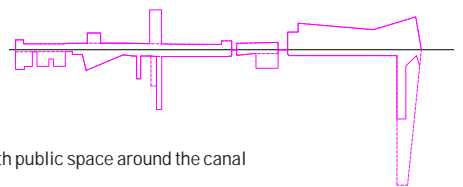

width public space around the canal

EXISTING AND NEW WATER AND PUBLIC SPACES



Currently the canal divides the city. Goal of this project is to transform the canal into a linking element, so that the canal can be included in the city network. In this way the canal can become a new entrance to the city.

The water is able to support a diversity of urban spaces, feelings and experiences. The proposed spaces will have the ability to change activity and flow constantly, by the hour or by the season.

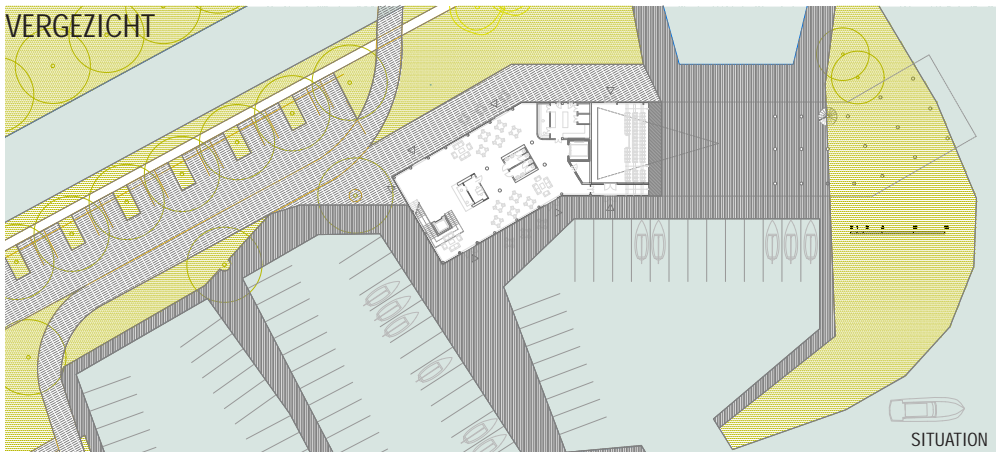

VERGEZICHT

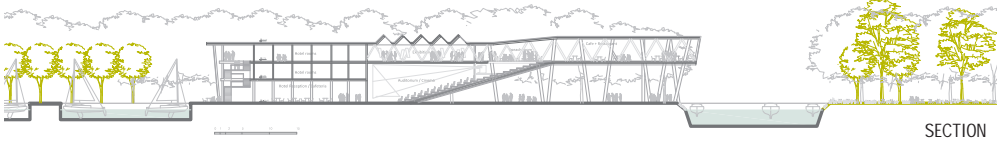
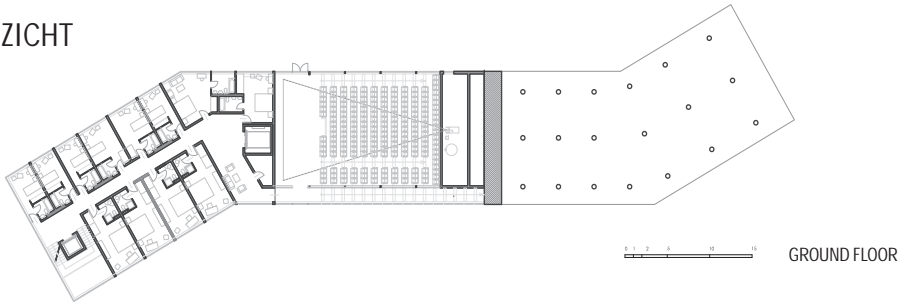

The layout of the park and green areas near the entrance refer to the Dutch tradition of creating polders with planting plots perpendicular to the water edge. The Vergezicht building, with a hybrid function, is facing a green environment in multiple directions.

De Wijde Blik is a mixed use building. The differences in function can be clearly distinguished by material use. The shops and offices are situated at the ground floor. Here a big opening towards the canal emphasizes the relation with the water.

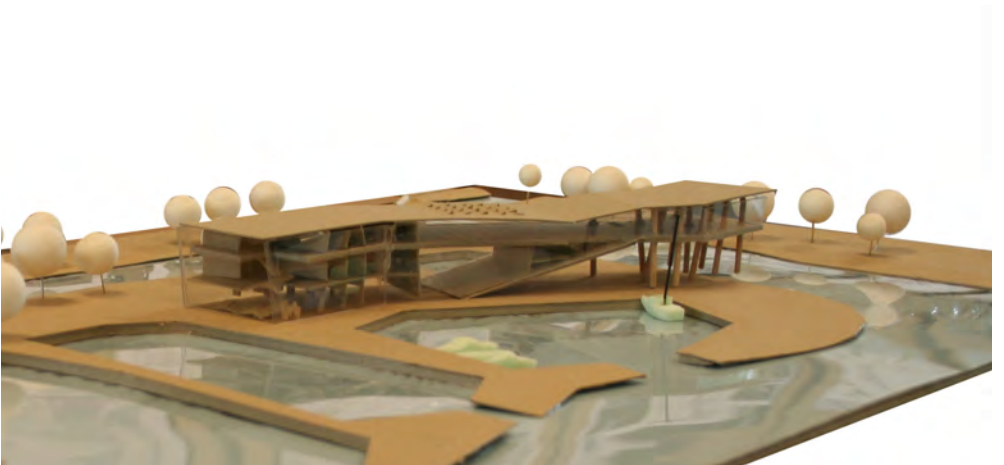

DE WIJDE BLIK

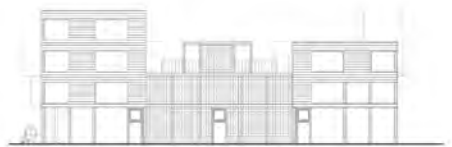
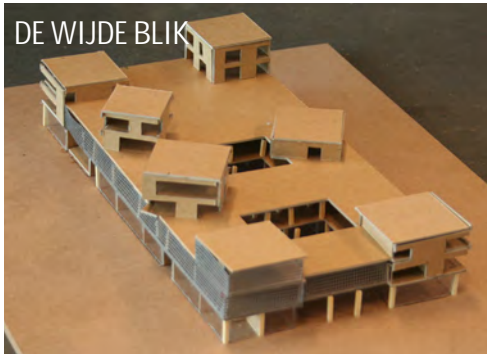

FACADE ELEVATION: TOWARDS INNER STREET



FACADE ELEVATION: EAST SIDE

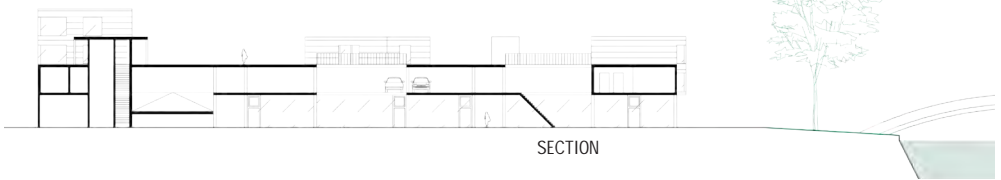

SECTION

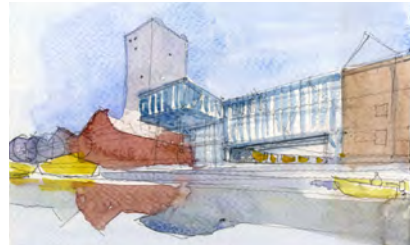

KANAALZICHT



GROUND FLOOR

DE WIJDE BLIK

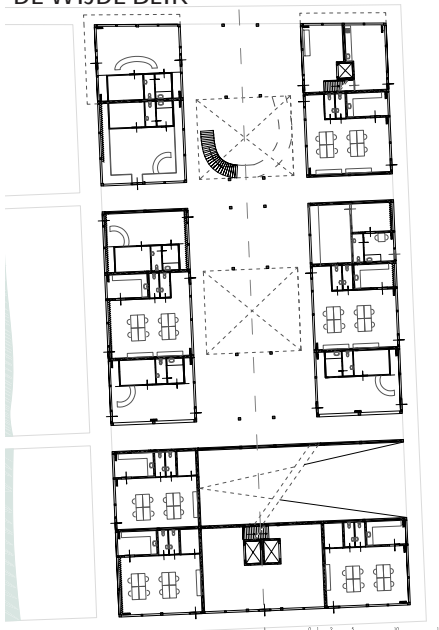

GROUND FLOOR



3rd FLOOR

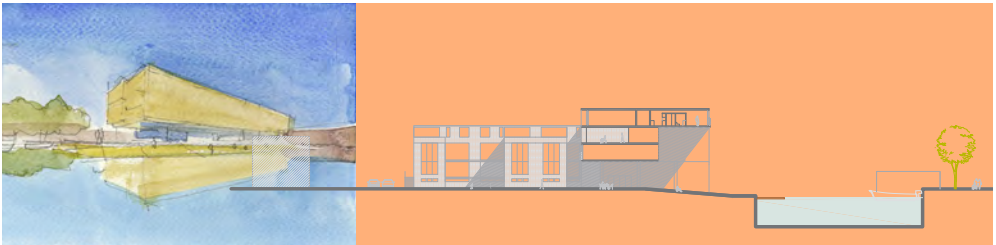

KANAALZICHT

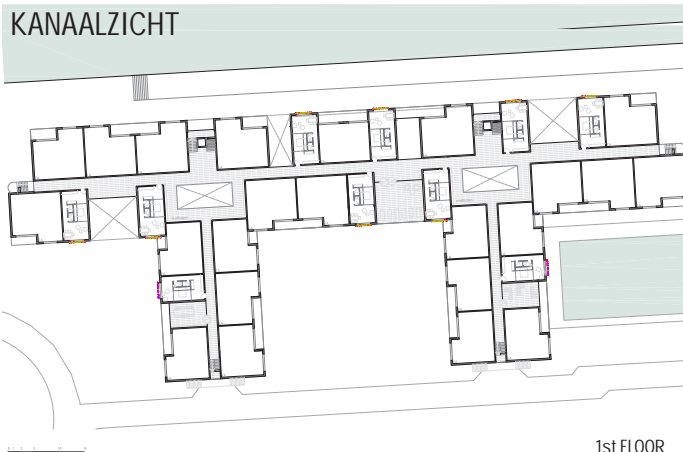

1st FLOOR

The existing building acts as a physical and visual barrier that obstructs moving and looking from city to canal. By emptying the ground floor and transforming it in a public space, we make the canal accessible again.

Horizontal and vertical perforations try to improve the quality of the upper floors. These perforations create a new typology of dwelling.



WATERDROPS

alexa BAUMGARTNER
annamaria MAURER
xaviera BURON KLOSE

CONCEPT influencing the neighborhood



SOUND

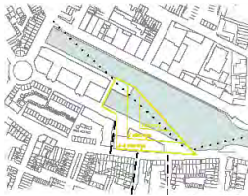

- █ building area
- ⋯ viewing axes
- - - walking axes

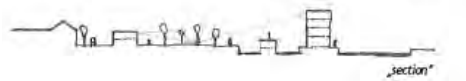

platform - nightlife - bar - restaurant - library - school - youth centre - student housing

DISSOLVE practice
 INTERACTIVE perform
 OPEN - CLOSED listen
 HEIGHT exchange
 combine float out

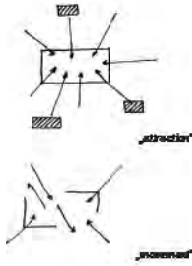

playground - exercising room - stage - dressing room - storage room

PLAY

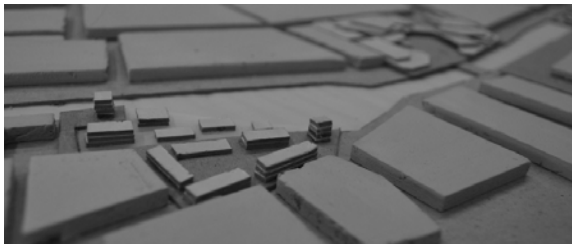

LAYER move LEVEL act
 SHELTER climb SMOOTH
 jump PLAYSCAPE speak



community centre - studio - kiosk - supermarket - bar - restaurant - toilet - bike storage - parking area

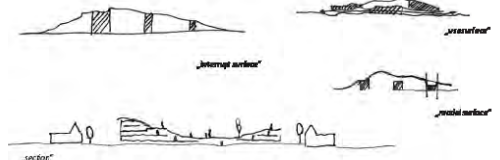

MOVE

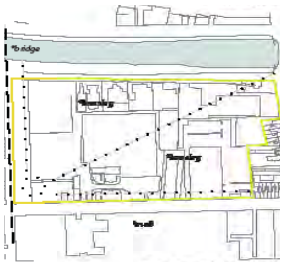

- building area
- viewing axes
- walking axes
- SPIRAL relax
- CENTRE enjoy
- WATERLINES breath
- INTROVERT fall
- EXTROVERT

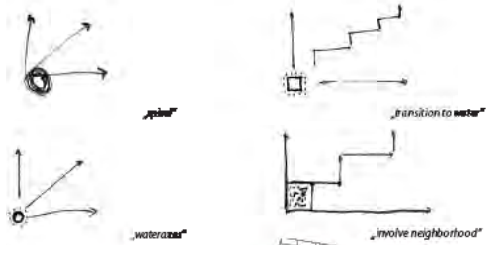

nature - green - air - water - health - sport - dance

ATTRACT



- building area
- viewing axes
- walking axes

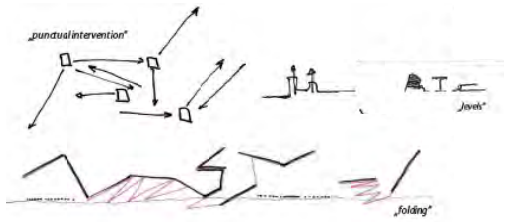

- EXPRESSION practice
- ACTION perform
- HIGH - LOW swim
- SPOTS watch
- VIEWING LINES
- MOTION

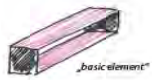
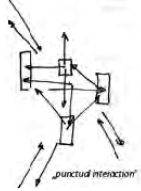

CREATE

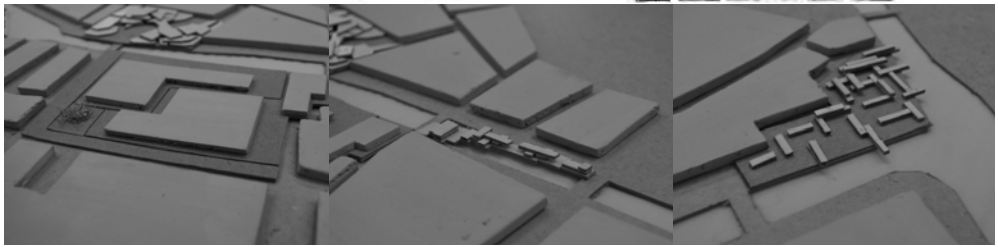

- TRANSITION reflect
- SEQUENCE show
- MOVEABLE observe
- LIGHT paint
- SHADOW build

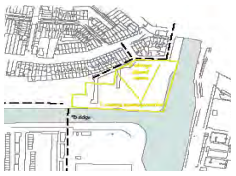

exhibition - creativity -
workspace - workshop - studio - housing - chill out

urban development SOUND



- 1 offices, vista
- 2 entrance, bar, café, terrace, stage, chill out
- 3 vista, covered stage
- 4 terrace, recreation
- 5 youth center: gym, auditorium, storage, rest room, dressing room, common room, activity rooms, internet access point, kitchen, terrace
green court, outer space
- 6 library: reception, administration, reading room, shelves, storage, restroom
- 7 recording studio: studios, offices, vista
- 8 music playground, green space, recreation
- 9 dance and music school: classroom, temporary rooms, common practice, backstage, stage, teacher's room, restrooms, dressing rooms, green court
- 10 student housing: personal spaces, common rooms, kitchen, bike storage, laundry, administration, green court

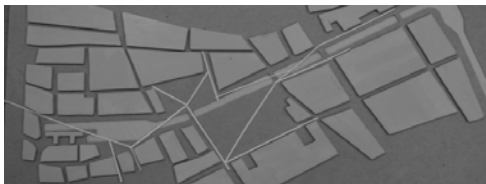
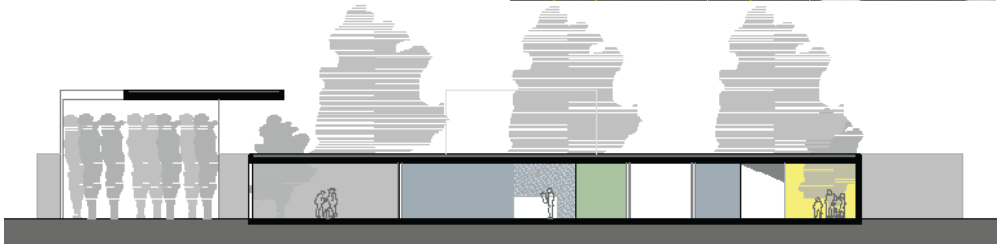
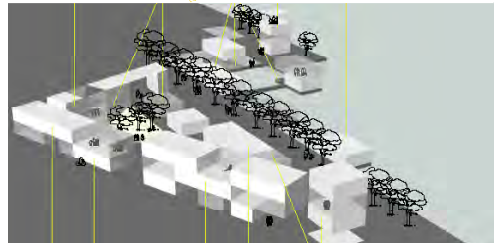
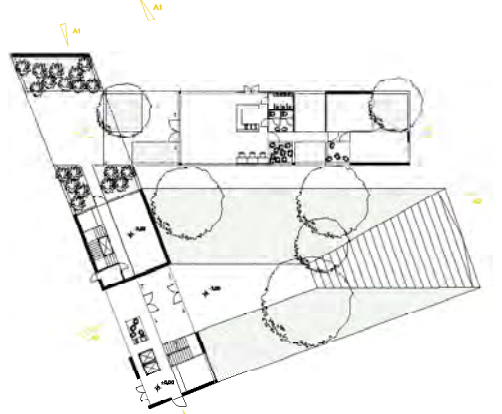
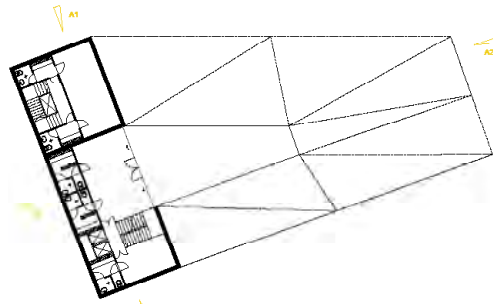

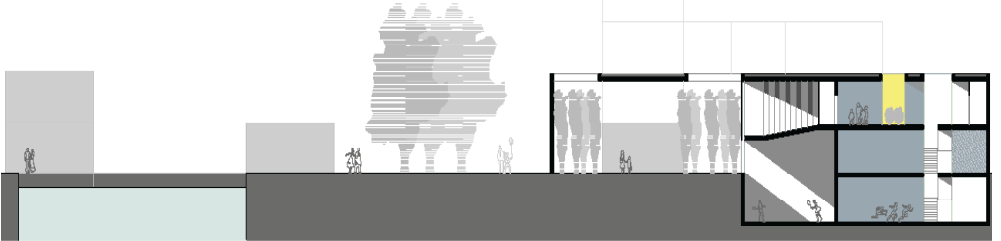
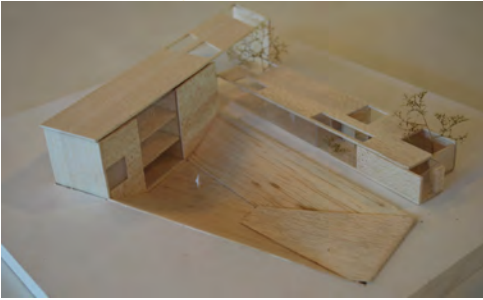
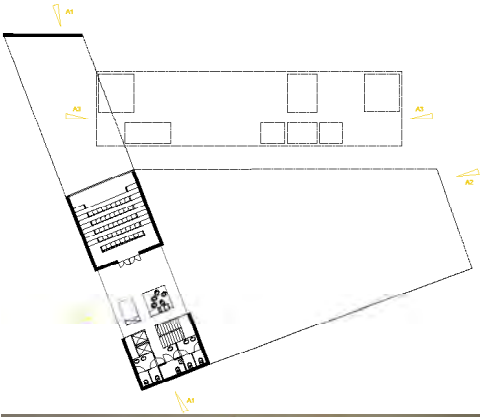

urban development ATTRACT

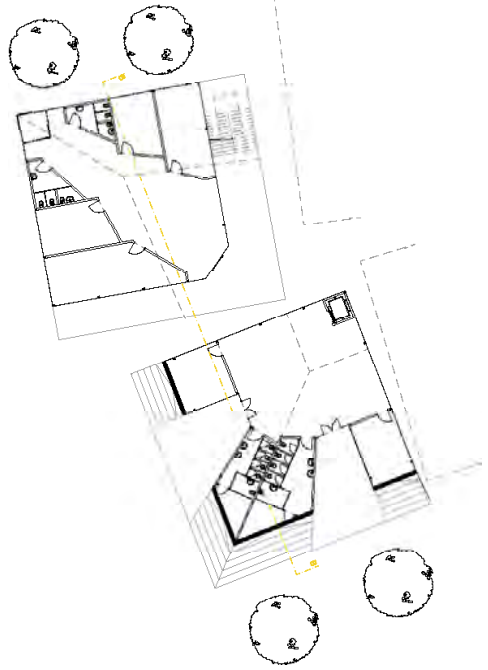
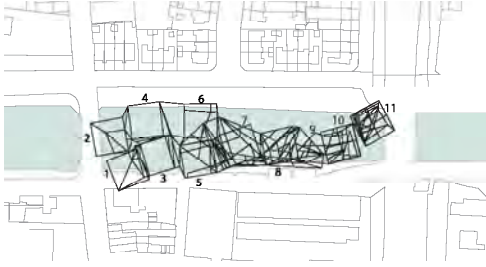

- 1 cash, service, info, shop
- 2 cash, service, info, administration
- 3-4 auditorium, toilets, wardrobe
- 5-6 acrobatics, dressing room, toilets
- 7 climbing area, emergency room
- 8 gym, storage room, dressing room, shower
- 9 terrace, bar, restaurant, chill out, toilets
- 10 swimming, beach, dressing room, shower
- 11 holiday housing

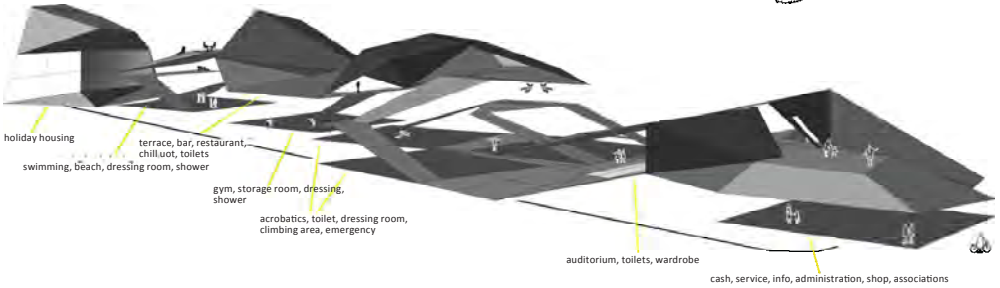

- holiday housing
- terrace, bar, restaurant, chill out, toilets
- swimming, beach, dressing room, shower
- gym, storage room, dressing, shower
- acrobatics, toilet, dressing room, climbing area, emergency
- auditorium, toilets, wardrobe
- cash, service, info, administration, shop, associations

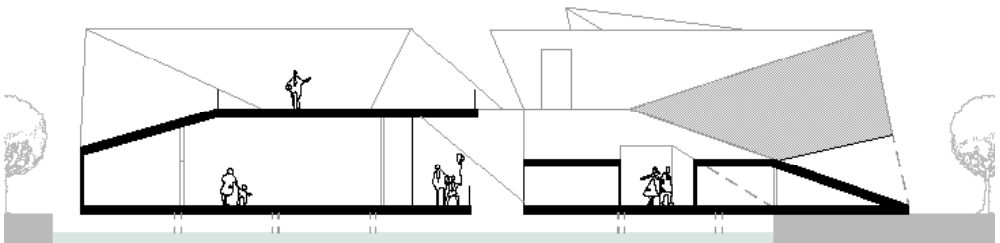

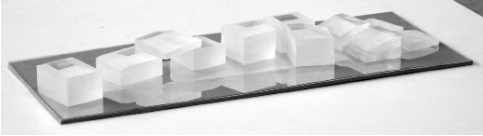
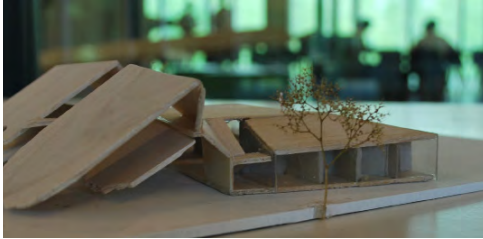
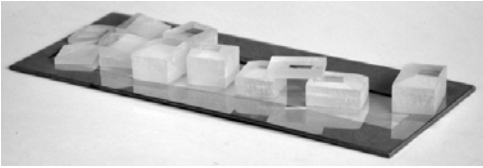
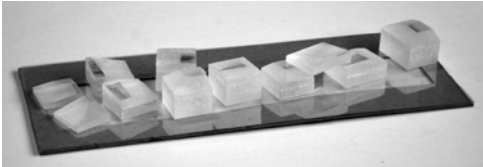
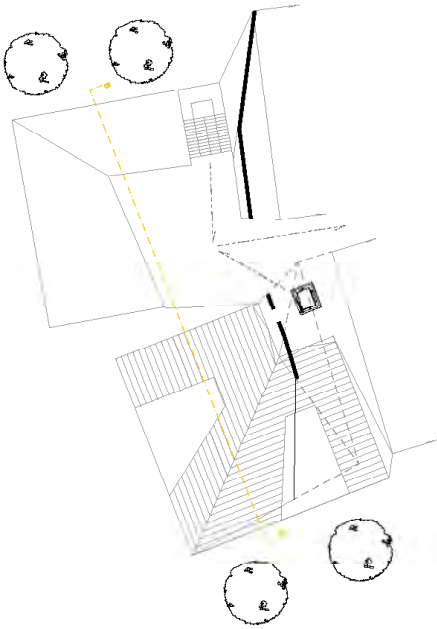

urban development CREATE

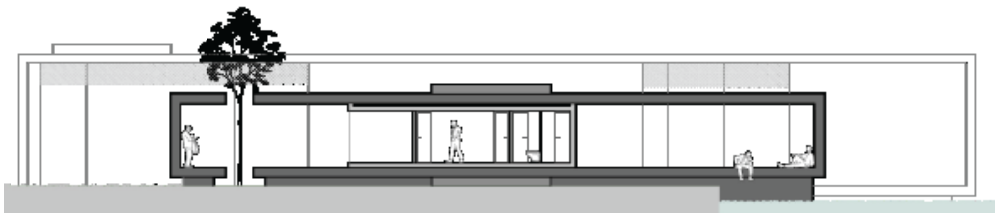
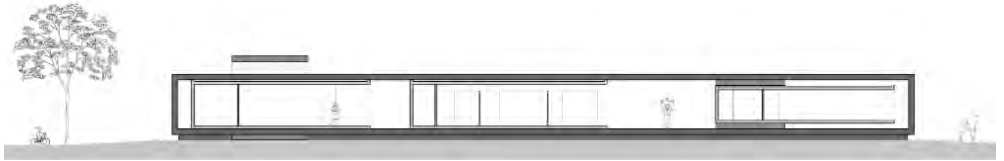
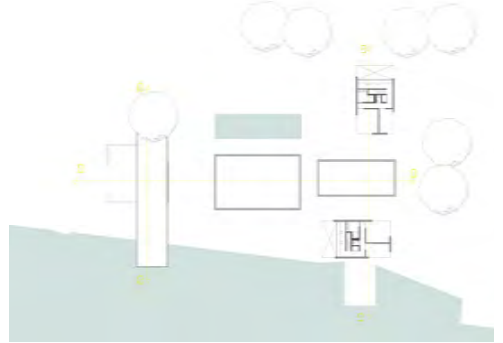
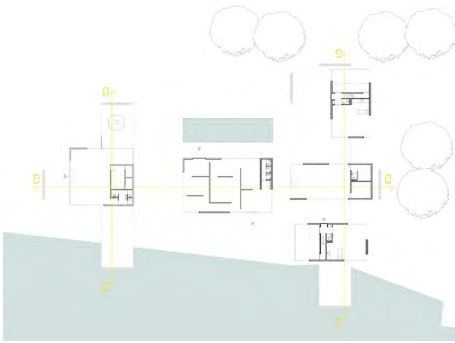

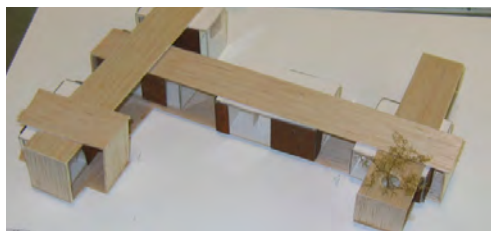
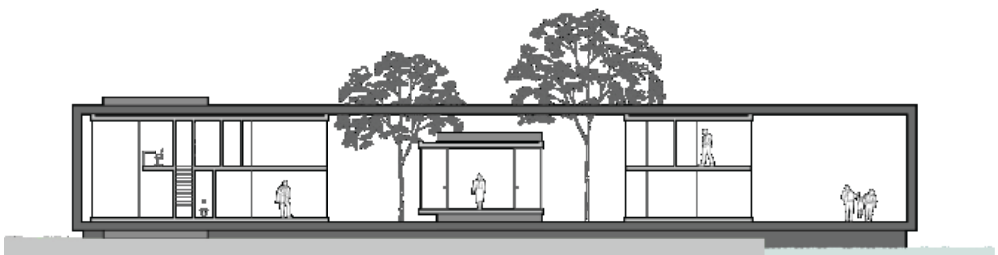
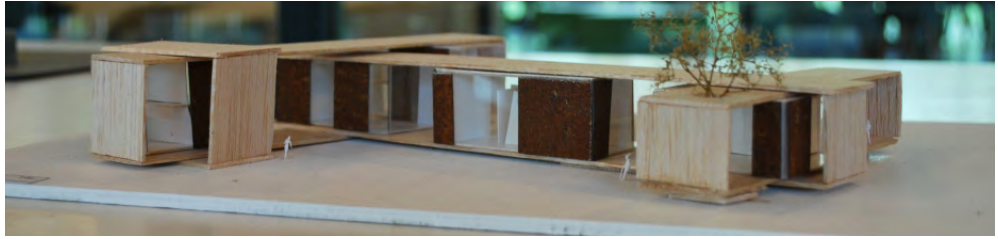
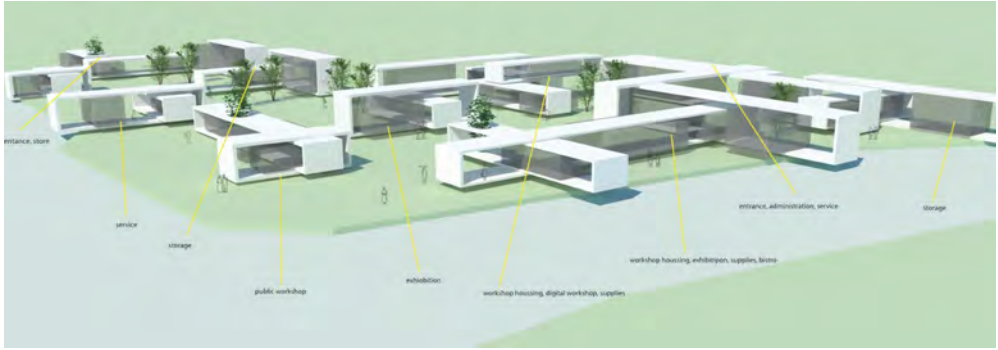



EVOLVING NATURE

françois LOTY
giulia ORLANDI

SITUATION ANALYSIS existing context

When we visited Tilburg for our first time, after arriving at the station, we followed the red path, the main one. During the complete walk we were really “waiting for the water”, looking for the canal zone...



All of a sudden, the canal was there, unforeseen, unannounced, as a complete surprise. It did not attract, it did not welcome.

Coming back from this experience, we decided that this characteristic background had to be renovated...to rejuvenate!

Full / Closed



/Vs

Open / Empty



the SKYLINE a CONTRAST between LOW and HIGH



an AREA made of CONTRAST

dwelling

streets



VEGETATION

/Vs

CONSTRUCTION

/Vs

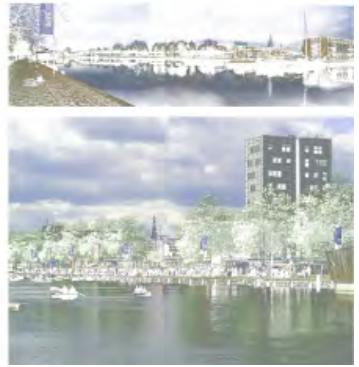
CANAL**actual situation**

The Piushaven seems to be outside of the city, moreover it seems to be lacking an identity. No activities are taking place there other than some special festivities on given days. The assets of the canal zone are being neglected.

regenerated situation

In a regenerated situation there would be dynamic activities for everyone. Daily crowd movements. A relationship between the Piushaven and the centre must be formed. Reinvestigation of the waterfront. Creation of a real architectural identity visible from far to facilitate the access.

projected situation

The ultimate objective would be to include the Piushaven as an extension of the city centre. As a result there would be daily crowd movement from the centre and other parts of the city to the Piushaven.

**highness****waterfront**

READING THE CONCRETE



READING THE NATURE





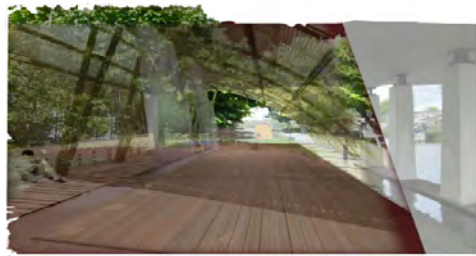

1



3

RELATION VEGETATION AND CONCRETE



-  high concrete density and middle vegetation
-  housing and dense vegetation
-  low vegetation density
-  high vegetation density

CREATE AN IDENTITY

the surprise thematique

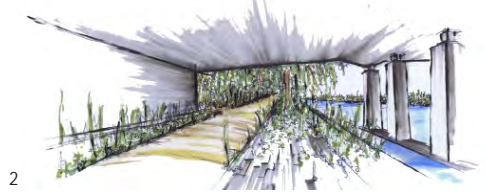

2



4

FIRST MASTERPLAN



ADD FUNCTIONS

Outside activities are made by people and made for people, that is why it is necessary to keep attracting people every year. Creating a campus near these functions reminds of the industrial past of the Piushaven and can promote a regeneration of all the area.



MIX FUNCTIONS

An interesting point of this strategy is how different knots have been created between functions and space typologies. In this way everyone can easily meet even if the activities differ.



INTEGRATE THE GREENARY



Is the greenary entering the city or is the city entering the greenary?

No more boundary between grassland and city.

The dialogue between vegetation and concrete creates public spaces and different ways to access the canal, but also to the park.

When walking along the canal it becomes immediately clear that there are various forms of vegetation in different residential areas.

The strategy tries to incorporate the relation between the intensity of vegetation and concrete. Low vegetation among the lower concrete areas has been intensified. High vegetation intrudes the area from the east, thereby creating a new residential area that continues from the east side of the canal to the high concrete west end of the canal.

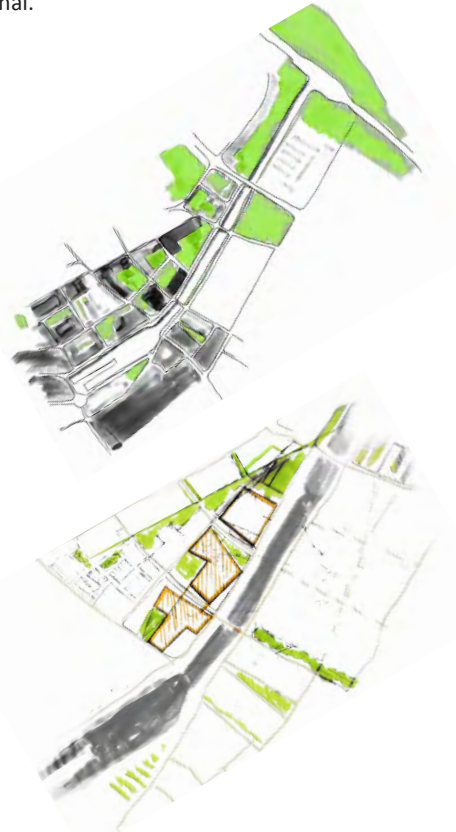



- school buildings and housing
- existing housing
- new residential housing
- new student housing
- rehabilitated student housing
- shops

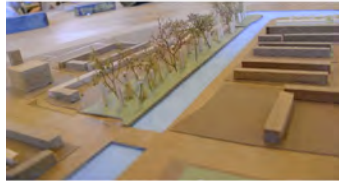

The public spaces are opened to each other and are not surrounded by buildings.



Thus the perception of spaces is more fluid and the connections between the centre, the Piushaven and the meadows are more enjoyable and understandable.



TREE houses
the FOREST housing

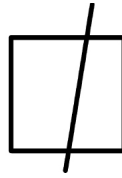

Every house is based on a prototype of a cut cube.

STUDENT house for 4 students

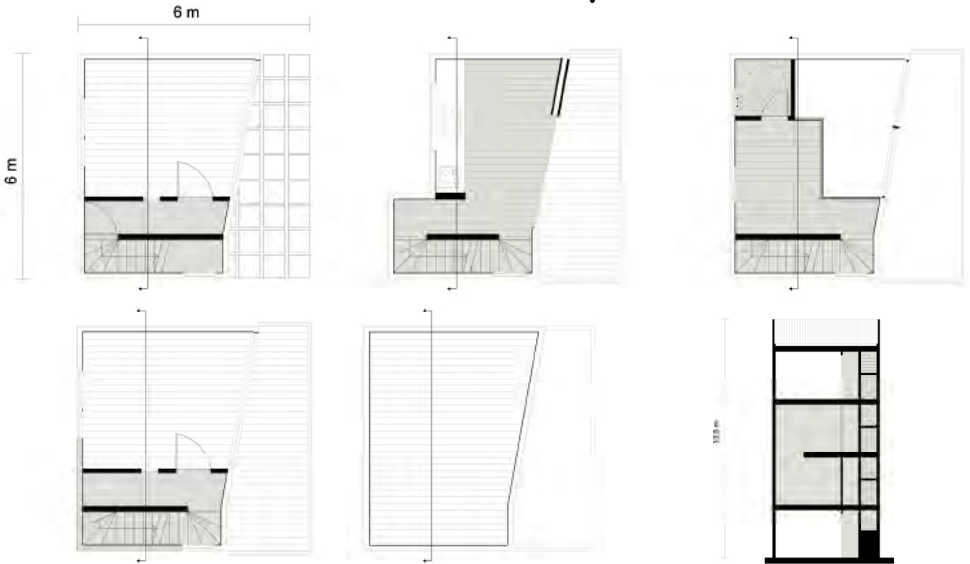

FAMILY house for 4 to 6 people

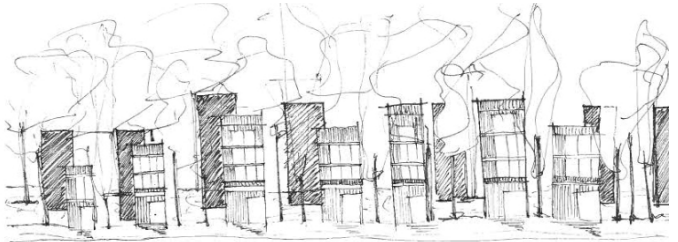

COUPLES house for 4 people



DESIGN SCHOOL

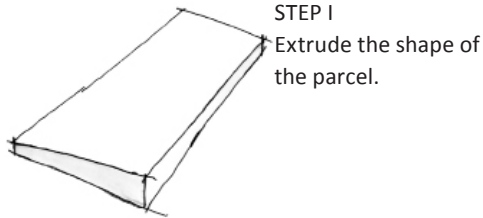

STEP I
Extrude the shape of the parcel.

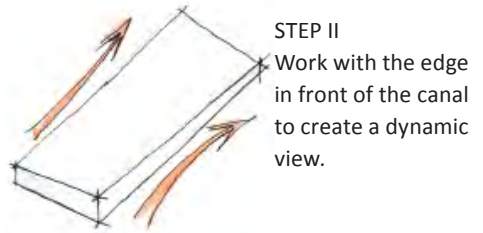

STEP II
Work with the edge in front of the canal to create a dynamic view.

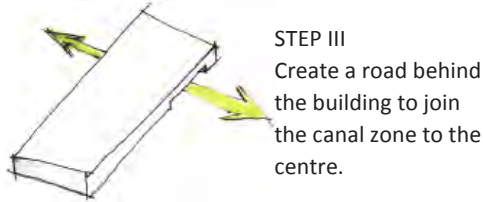

STEP III
Create a road behind the building to join the canal zone to the centre.

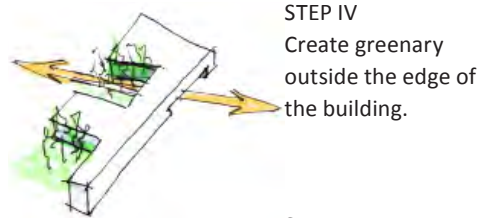

STEP IV
Create greenery outside the edge of the building.

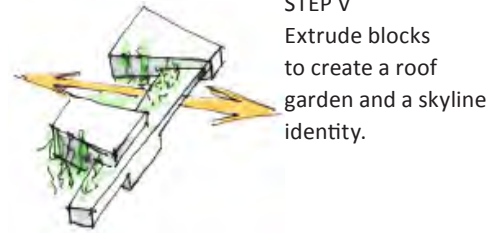

STEP V
Extrude blocks to create a roof garden and a skyline identity.

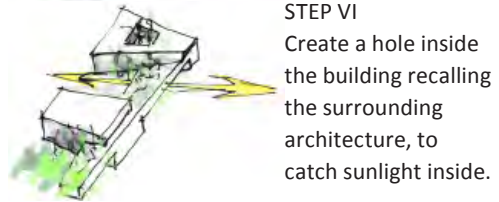

STEP VI
Create a hole inside the building recalling the surrounding architecture, to catch sunlight inside.



Upon entry, a play of floors unveils: both floors offer a different perception of the canal. The first floor encourages people to walk along the canal and to get closer to it. The opacity and transparency of the walkway are ways to play with the perception and allow the walkway to merge with the canal. The library forms a wide corridor between both buildings across the street. In front of the canal, it provides a high and wide space for quiet reading. As long as the walkway continues, more spaces become transparent and oriented to downtown as well as to the canal. These spaces are visible from all sides.

On the second floor above the library, a cafeteria has been situated. Bright and sunny; it is an ideal place for lunching and relaxing. In between critical rooms for brainstorming, different spaces allow everyone to relax and reflect in front of the canal or facing the centre. The top floor is mainly composed of exhibition areas. From here, the holes through the middle of the building allow to see what happens in the school. In this way, the visual relationship is not just horizontal, but also vertical. It allows a perpetual game between shadows and lights.

SECTION A



SECTION B

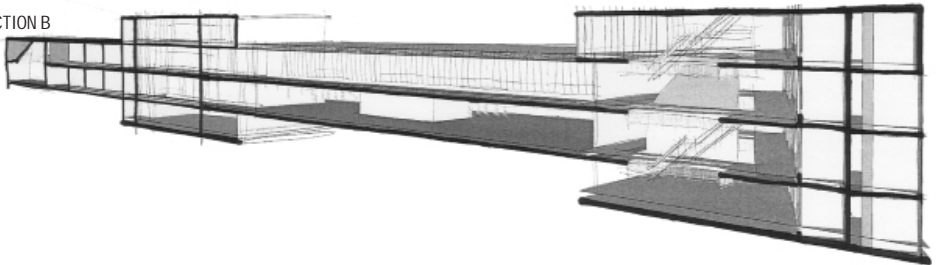

SECTION C



FINAL PRESENTATION - EPILOGUE



group 1

Apart from the loads of fun we had during this semester, the studio was extremely instructive and proved to be a great opportunity to gain experience in working as a multidisciplinary and multicultural team. An essential contribution to my studies I reckon.

Martijn Maassen, *the Netherlands*



group 2

I can say with all certainty that I will always remember this semester as the most funniest and the most trailblazing semester of my four years of study at the TU/e, all thanks to this international master project. Through this project I came upon various ways of thinking either on architectural, urban or sociocultural level. The experience and knowledge that my group mates gained were sometimes surprising and sometimes very refreshing. It was very interesting to see how students from different countries participated in a Dutch project and what they thought of Dutch building culture.

Katia Kevork, *the Netherlands*



group 3

This project has created an interesting connection of architecture with urban design. Instead of changing the parameters of just one building, one will have to handle several in an entire area.

The project was a success, due to the different talents in our team. With three people per team, with different backgrounds, we could really divide the work by our own talent. Discussion, which started automatically, allowed us to reach a higher level in this project than in an individual one.

Dik de Voogd, *the Netherlands*

Our studio project has been a great adventure. It was nice to collaborate in international teams with students having different backgrounds. The project's location: the Piushaven in Tilburg, was very interesting. I enjoyed working on different scale levels; developing an urban strategy as well as architecture. It was exciting to make many models in every stage of the process and to get feedback from Tilburg city planners.

Franek Ryczer, *Poland*



group 4

Doing the Tilburg 'kanaalzone' project was a really nice experience. Meeting people from different countries and working with them not only changed my view on architecture, but on culture as well. Tilburg was a nice place to discover this.

Willeke Klomp, *the Netherlands*

Taking part in the 'industrial waterfronts masterproject' was an interesting opportunity in my vocational training. Working in groups was the main idea of the workshop and, at the same time, it was very enriching for me as a person and as a professional. The professor, Irene Curulli, has chosen to adopt a secondary role, giving small advices and empathising with our ideas. In this way I learnt to listen to my partners, understand our cultural differences and appreciate my group mates' knowledge. After hard work, projects grew from the group dialogue and understanding.

Ana Rodriguez Lopez, *Spain*



group 5

This experience was really interesting, because it was a mix of developing urban concepts and planning housing for the city of Tilburg. It was also really nice to see how the place changed from winter to spring, this was very helpful to understand all the potentials of the project. The fact that we were constantly encouraged by the teacher to build models and research our feelings and thoughts about the place, was again really helpful. Something that I had always missed in my student life was meeting with the client; people of the municipality of Tilburg, it proved that we were really doing something important both for our studies and for them. Thanks to everyone.

Guilia Orlandi, *Italy*



group 6