

Controlled nanoparticle formation by diffusion limited coalescence

Citation for published version (APA):

Stepanyan, R., Lebouille, J. G. J. L., Slot, J. J. M., Tuinier, R., & Cohen Stuart, M. A. (2012). Controlled nanoparticle formation by diffusion limited coalescence. *Physical Review Letters*, 109(13), 1-5. Article 138301. <https://doi.org/10.1103/PhysRevLett.109.138301>

DOI:

[10.1103/PhysRevLett.109.138301](https://doi.org/10.1103/PhysRevLett.109.138301)

Document status and date:

Published: 01/01/2012

Document Version:

Publisher's PDF, also known as Version of Record (includes final page, issue and volume numbers)

Please check the document version of this publication:

- A submitted manuscript is the version of the article upon submission and before peer-review. There can be important differences between the submitted version and the official published version of record. People interested in the research are advised to contact the author for the final version of the publication, or visit the DOI to the publisher's website.
- The final author version and the galley proof are versions of the publication after peer review.
- The final published version features the final layout of the paper including the volume, issue and page numbers.

[Link to publication](#)

General rights

Copyright and moral rights for the publications made accessible in the public portal are retained by the authors and/or other copyright owners and it is a condition of accessing publications that users recognise and abide by the legal requirements associated with these rights.

- Users may download and print one copy of any publication from the public portal for the purpose of private study or research.
- You may not further distribute the material or use it for any profit-making activity or commercial gain
- You may freely distribute the URL identifying the publication in the public portal.

If the publication is distributed under the terms of Article 25fa of the Dutch Copyright Act, indicated by the "Taverne" license above, please follow below link for the End User Agreement:

www.tue.nl/taverne

Take down policy

If you believe that this document breaches copyright please contact us at:

openaccess@tue.nl

providing details and we will investigate your claim.

Controlled Nanoparticle Formation by Diffusion Limited Coalescence

R. Stepanyan,¹ J. G. J. L. Lebouille,¹ J. J. M. Slot,^{1,2} R. Tuinier,^{1,3} and M. A. Cohen Stuart⁴

¹DSM Research, PO Box 18, NL-6160 MD Geleen, The Netherlands

²Department of Mathematics and Computer Science, Eindhoven University of Technology,
PO Box 513, 5600 MB Eindhoven, The Netherlands

³Van 't Hoff Laboratory for Physical and Colloid Chemistry, Debye Institute, Utrecht University,
Padualaan 8, 3584 CH Utrecht, The Netherlands

⁴Laboratory of Physical Chemistry and Colloid Science, Wageningen University,
Dreijenplein 6, 6703 HB Wageningen, The Netherlands

(Received 17 March 2012; published 27 September 2012)

Polymeric nanoparticles (NPs) have great application potential in science and technology. Their functionality strongly depends on their size. We present a theory for the size of NPs formed by precipitation of polymers into a bad solvent in the presence of a stabilizing surfactant. The analytical theory is based upon diffusion-limited coalescence kinetics of the polymers. Two relevant time scales, a mixing and a coalescence time, are identified and their ratio is shown to determine the final NP diameter. The size is found to scale in a universal manner and is predominantly sensitive to the mixing time and the polymer concentration if the surfactant concentration is sufficiently high. The model predictions are in good agreement with experimental data. Hence the theory provides a solid framework for tailoring NPs with *a priori* determined size.

DOI: [10.1103/PhysRevLett.109.138301](https://doi.org/10.1103/PhysRevLett.109.138301)

PACS numbers: 82.35.Np, 81.07.-b

Polymeric nanoparticles (NPs) are gaining increasing attention because of their numerous applications in, for instance, physics, chemistry and medicine [1]. The NP size and size distribution are the key parameters often determining their functionality. Therefore, one of the main experimental challenges is to prepare NPs with well controlled dimensions tuned for a particular application. Models of NP formation, allowing one to steer the NP preparation process in the right direction, would simplify the size control significantly.

A high level of control over particle size is required in, for example, targeted delivery (e.g., oncology). Size influences the circulating half lifetime and is crucial for selective cellular uptake: NPs between 50 and 200 nm in size are desired in passive cancer tumor targeting as they are too large to harm healthy cells but small enough to penetrate into the diseased ones. In brain imaging, fluorescent dye loaded particles of about 100 nm with biocompatible polymer coatings are used because they produce small, sharply defined injection sites and show no toxicity *in vivo* or *in vitro* [2–4].

Although there are several methods for NP preparation, only few of them permit a high level of control on the particle size and the particle size distribution [2]. Often, a water insoluble moiety (e.g., a drug or a dye), needs to be encapsulated into a carrier polymer and protected by an emulsifying agent, which also makes the NP water soluble. In particular, the so-called nanoprecipitation method permits preparation of nearly monodisperse NPs in a very simple and reproducible way [5]. Typically, an organic phase, which is usually a dilute polymer solution,

e.g., polycaprolactone (PCL) in acetone, plus the hydrophobic moiety to be encapsulated, e.g., a drug or a fluorescent dye, is injected by pressure into an aqueous solution of the emulsifying agent, Fig. 1(a). As the organic solvent is chosen to be water-miscible, rapid quenching (towards poor solvent conditions) of the hydrophobic polymer and the drug in water takes place. This results in coalescence of the polymer and the drug into submicron particles decorated by surfactant [2,6]. Alternatively, a block copolymer can be used to combine the polymeric drug carrier and surfactant roles into a single component. To promote a faster and better controlled mixing, an impinging jets mixer, Fig. 1(b), has been employed in this case [4,7].

Despite the simplicity of the experimental method, one still lacks a comprehensive theoretical model that allows us to predict how particle size depends on the materials and process parameters, in particular on concentration. Therefore in many practical situations investigators still resort to simple empirical correlations [8] or to statistical methods such as experimental design [6]. More advanced theoretical methods, such as Brownian dynamics simulations [9] or population balance coupled to computational fluid dynamics simulation [10], do provide very valuable insights into the kinetics of mixing and rapid assembly upon quenching but do not permit formulation of a simple yet physically meaningful analytical relationship between the experimentally relevant parameters and the NP size. Such a relationship would be extremely useful in designing NPs with *a priori* determined size as it would allow one to avoid a very laborious trial and error process.

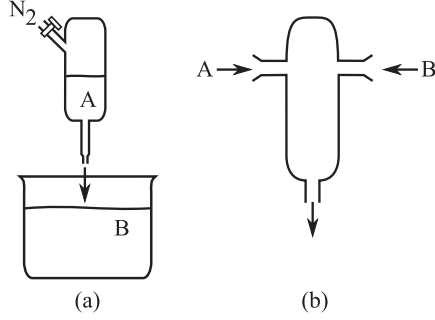

FIG. 1. Scheme of a pressure driven injection device used in Ref. [6] (a) and an impinging jets mixer used in Ref. [7] (b). Fluid A is the organic phase comprising solvent, the carrier polymer and the drug, fluid B is an aqueous solution of emulsifying agent.

In this Letter we formulate a model of the nanoprecipitation process. The model grasps all essential features of the process and, at the same time, provides a simple analytical expression for the NP size as a function of the mixing intensity and the surfactant and polymer properties.

We restrict ourselves to a bicomponent system: a dilute solution of a hydrophobic polymer is injected into a water-surfactant solution. Because the solvent and water are chosen to be well miscible, a rapid quench of the hydrophobic polymer in water takes place and the polymer particles start to coalesce upon encounter to form larger particles. In parallel, the surfactant molecules, also subject to Brownian motion, adsorb on the surface on the newly formed polymeric particles and make their coalescence progressively more difficult until a stable situation is reached. As the NPs formed represent a system in a kinetically frozen state, their parameters will depend strongly on the system kinetics, which includes at least three processes: namely, (i) mixing of the polymer plus solvent with the aqueous surfactant solution taking place on the time scale τ_{mix} ; (ii) coalescence of the hydrophobic polymer particles in a hostile water environment, characterized by a time τ_{cls} ; and (iii) protection of the polymeric NPs by the surfactant taking place on the time scale τ_{pro} and bringing the system into a kinetically frozen state.

Let us first consider the limit of “very fast mixing” $\tau_{\text{mix}} \rightarrow 0$, in the absence of surfactant. The system then initially consists of collapsed polymer molecules homogeneously distributed in water. These molecules will diffuse, collide, and stick. If they were hard particles, this would lead to fractal aggregates, for which well-known growth laws have been developed. This case is commonly known as “diffusion limited aggregation”. However, as our particles are liquidlike, they will coalesce to homogeneous spherical particles rather than forming fractal aggregates, so that we deal with “diffusion limited coalescence” (DLC) [11]. For this we have the Smoluchowski theory [12] with a rate $K = 4\pi D' R'$, where D' and R' are the sum of the diffusion coefficients and the radii of the reacting

species, respectively. Hence, in a mean field approximation, the polymer particle concentration c_p is governed by a simple equation

$$\frac{dc_p}{dt} = -\frac{8}{3} \frac{k_B T}{\eta} h c_p^2, \quad (1)$$

where the Stokes-Einstein expression $D_p = k_B T / (6\pi\eta R_p)$ for the diffusion coefficient of a particle in a fluid with viscosity η has been used. The factor h accounts for the probability that a collision leads to a coalescence event.

The surfactant adsorbed on the particle surface influences h , as it reduces the probability of a coalescence event to occur. Hence, h is a function of the fraction of the particle surface protected by the surfactant, $h \equiv h(n(t)a^2/[4\pi R_p^2(t)])$, where $n(t)$ denotes the average number of surfactant molecules adsorbed on a polymer particle with radius R_p at time t , each surfactant molecule covering a surface area a^2 .

Since we are dealing with coalescence rather than aggregation, there is a direct relation between particle mass and particle radius R_p leading to the mass conservation law in the form $c_p(t)R_p^3(t) = c_{p0}R_{p0}^3$. Here, R_{p0} and c_{p0} are the size and the number concentration of the polymer particles immediately after the mixing takes place.

In the absence of surfactant, $h(\cdot) \equiv 1$ and (1) can be recast in terms of the particle size yielding $R_p^3(t) = R_{p0}^3(1 + t/\tau_{\text{cls}})$, with an encounter and coalescence time

$$\tau_{\text{cls}} = \frac{3}{8c_{p0}} \frac{\eta}{k_B T}. \quad (2)$$

Assuming strong favorable interaction between polymer and surfactant, the surfactant-polymer coagulation can be treated in a similar manner

$$\frac{dc_s^{\text{free}}}{dt} = -\frac{2}{3} \frac{k_B T}{\eta} \left(\frac{1}{R_p} + \frac{1}{R_s} \right) (R_p + R_s) c_s^{\text{free}} c_p h_s, \quad (3)$$

where R_s and c_s^{free} are the diffusion radius and the concentration of the free (not adsorbed) surfactant molecules; $h_s = h_s(na^2/(4\pi R_p^2))$ denotes the probability of adsorption. Eq. (3) is a straightforward generalization of (1), where a relative diffusivity has been introduced as a sum of the polymer particles and the surfactant molecules diffusivities (see Ref. [13] for more details). Also, the reaction radius is assumed to equal $R_p + R_s$.

An interesting observation at this point is that $\tau_{\text{pro}} \sim \tau_{\text{cls}}$ and, hence, the collision rate of the polymer particles and their protection by the surfactant go at approximately the same pace. Note, that we have neglected surfactant micellization by assuming that the surfactant molecules bound in surfactant micelles behave similarly to the dissolved ones, at least in what concerns their agglomeration with polymeric NPs.

To describe the kinetics of coagulation, the exact functional form of h and h_s must be specified and the Eqs. (1) and (3) need to be solved together. In fact, as we are only interested in the final particle size and not its time dependence, we can divide (1) by (3) yielding a single differential equation for c_p as a function of c_s^{free} . Computing the exact form of $h(\cdot)$ can be quite involved, although it is clear that $h(0) \simeq 1$ and $h(1) \simeq 0$. The same holds for h_s . To simplify the matter significantly, we assume the surfactant adsorption not to influence the coalescence of particles until the particles are saturated with the surfactant and the coalescence is stopped completely [14] and take $h(0 \leq x < 1) = 1$ and $h(x \geq 1) = 0$ and the same for h_s . Such a choice does not change the scaling of all the important quantities but implies that the coagulation process stops when $n = 4\pi R_p^2/a^2$ and, hence, $c_{s,\text{end}}^{\text{free}} = c_{s0} - 4\pi(R_p^{\text{end}})^2 c_p^{\text{end}}/a^2$. Solving the differential equation for c_p as a function of c_s^{free} explicitly and making use of the above relation between the end values of the concentrations and the radius, one derives a transcendental equation for the ratio $\zeta = R_p^{\text{end}}/R_{p0}$ between the final and the initial particle size

$$1 - \exp\left\{-\frac{3}{4}\left[\ln\zeta + \alpha(\zeta - 1) + \frac{1}{\alpha}\left(1 - \frac{1}{\zeta}\right)\right]\right\} = \frac{\kappa}{\zeta}, \quad (4)$$

where $\alpha = R_{p0}/R_s$ is the ratio between the initial polymer particle size and the diffusion radius of the surfactant and $\kappa = 4\pi R_{p0}^2 c_{p0}/(a^2 c_{s0})$ is the ratio of the total initial surface area on the polymer particles to the maximum area surfactant molecules can occupy and block.

Analytical solutions of (4) are found for the limiting cases of an excess of surfactant, $\kappa \ll 1$, and if surfactant is scarce, $\kappa \gg 1$:

$$R_p^{\text{end}} = R_{p0} \times \begin{cases} 1 + \frac{\kappa}{3/4 + \alpha + \alpha^{-1}} & \text{if } \kappa \ll 1, \\ \kappa & \text{if } \kappa \gg 1. \end{cases} \quad (5)$$

This leads to a simple interpolation $R_p^{\text{end}} \simeq R_{p0}(1 + \kappa)$, which is surprisingly close to the exact numerical result.

A very peculiar implication of the fact that $\tau_{\text{cls}} \sim \tau_{\text{pro}}$, as pointed above, is that the final NP size does not depend on the mobility of polymer or surfactant molecules. The only dominating factor in the “fast mixing” limit, when $\tau_{\text{mix}} \ll \tau_{\text{cls}}$, is the surfactant concentration.

Let us now consider the other limit, $\tau_{\text{mix}} \geq \tau_{\text{cls}}$, which is apparently characterized by a very fast particle aggregation on the time scale shorter than the typical mixing time followed by stabilization of the NPs’ size at the times $t \geq \tau_{\text{mix}}$. Indeed, at the very beginning of the process, the polymers are present as isolated chains in a good solvent. As the solvent quality drops the polymers instantaneously collapse. Subsequent collision of collapsed chains leads to coalescence following the kinetics prescribed by (1) with $h \equiv 1$. Hence, the particle size at the end of the mixing, $t \simeq \tau_{\text{mix}}$, reads $R_{\text{mix}} \simeq R_{p0}(1 + \tau_{\text{mix}}/\tau_{\text{cls}})^{1/3}$. At longer times, there is enough time for the surfactant to adsorb

onto the surface of the coalescing polymer-rich droplets. Then the system finds itself in a well mixed state and its kinetics obeys the set of Eqs. (1) and (3) as discussed above, but R_{mix} must be used as the “initial” particle size in (4). This two-step process leads to a final expression for the polymer particle radius in a kinetically frozen state

$$R_p^{\text{end}} = R_{p0}(1 + \kappa) \left(1 + \frac{\tau_{\text{mix}}}{\tau_{\text{cls}}}\right)^{1/3}. \quad (6)$$

It is characterized by a plateau at small $\tau_{\text{mix}}/\tau_{\text{cls}}$, where the NP diameter is independent of mixing or encounter and coalescence time and is totally governed by the surfactant concentration (parameter κ) with the smallest particles obtained in excess of surfactant. The other regime, $\tau_{\text{mix}}/\tau_{\text{cls}} > 1$, shows a typical 1/3 power law behavior and is dominated by the mixing efficiency.

Based on (6) it follows that for typical experimental conditions, i.e., excess of surfactant and relatively slow mixing, the final NP size depends mainly on the mixing time and the initial polymer mass concentration c_{mp} , $R_p^{\text{end}} \propto (c_{mp} \tau_{\text{mix}})^{1/3}$, and is independent of the polymer molar mass. Only a minor dependence on the molar mass of the emulsifying agent can be observed indirectly via τ_{mix} , which can be sensitive to the viscosity of the surfactant solution. The same holds for the temperature.

To appreciate the formula (6) we compare its scaling predictions to our own experiments as well as to the data available in the literature. In the nanoprecipitation experiments performed in our lab, PCL (CAPA 6250 supplied by Solvay) has been used as a carrier polymer and Pluronic (PF127 supplied by BASF) as a surfactant. A PCL solution in acetone was quenched in a 1 wt% PF127 aqueous solution with a device similar to the one depicted in Fig. 1(a). The hydrodynamic particle diameter D_h has been measured by dynamic light scattering.

As can be seen from Fig. 2, our results compare favorably to the data available in the literature [6] for the same system. As the experiments are performed in the $\tau_{\text{mix}} > \tau_{\text{cls}}$ regime, the scaling obeys the 1/3 power law as expected. To check the molar mass sensitivity, additional experiments have been performed where PCL molar mass has been varied between 2 and 80 kg/mol. The diameter was, however, hardly affected by the molar mass (see inset in Fig. 2), in accord with the theoretical predictions.

The data presented only cover the $\tau_{\text{mix}} > \tau_{\text{cls}}$ regime and neither reach a particle size saturation limit at the very fast mixing, $\tau_{\text{mix}} < \tau_{\text{cls}}$, nor a crossover at $\tau_{\text{mix}} \sim \tau_{\text{cls}}$. However a very vast experimental data set is available for a somewhat different system comprising a methanol solution of an amphiphilic diblock copolymer (polybutylacrylate-*b*-polyacrylic acid, each block 7.5 kg/mol) quenched in water. By using a highly efficient impinging jet mixer, Fig. 1(b), Johnson and Prud’homme [7] succeeded in covering a very broad range of mixing

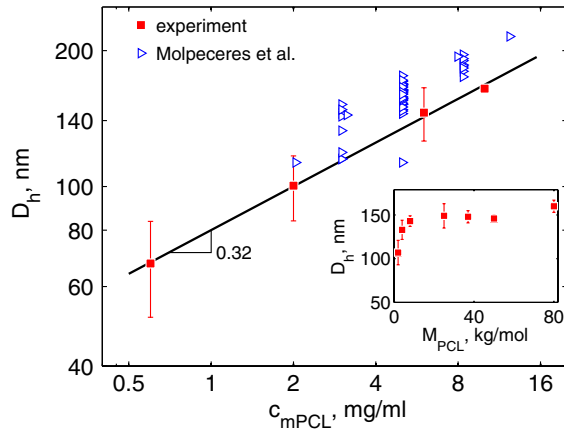

FIG. 2 (color online). Size of PCL (molar mass $M_w = 25$ kg/mol) NPs prepared from an acetone solution quenched in an aqueous Pluronic solution as a function of the initial polymer concentration. Solid line shows a fit to the data. Also the data from Molpeceres *et al.* [6] are shown. Inset: Size of NP vs molar mass of PCL, at concentration $c_{mPCL} = 5$ mg/ml.

times and observed all of the three above-mentioned regimes. Their original data—the hydrodynamic diameters of the micelles formed vs the mixing time—are shown in the inset of Fig. 3. The coagulation in a dispersion containing diblock copolymers must obey kinetics very similar to the one described by (1) and, thus, yield scaling (6) for the NP size. This implies that a master curve must be obtained in Fig. 3 if one shifts the data along the horizontal axis by the polymer mass fraction w_p . Moreover, a typical diameter scaling $(\tau_{mix} w_p)^{1/3}$ is expected to be observed at long mixing times.

One important difference between the concentration dependence of the size predicted in this Letter and the measurements in Ref. [7] is the fact that our Eq. (6) does not take into account the size of the surfactant layer on top of a NP. Indeed, such an approximation certainly holds in case of a polymeric surfactant. In case of diblock copolymers, however, the size of the hydrophilic corona surrounding the hydrophobic core cannot be neglected. To compute a hydrophobic core diameter from a hydrodynamic diameter of a copolymer micelle, we recall that the latter scales as a power 1/5 of the micelle mass [15]. As the core of a micelle consists almost solely of the hydrophobic polymer segments, the core size scales as a power 1/3 of the mass, yielding $R_{core} \propto D_h^{5/3}$. The data redrawn in $D_h^{5/3}$ vs $\tau_{mix} c_p$ coordinates, Fig. 3, indeed show a master curve obeying Eq. (6): it is characterized by a typical $(\tau_{mix}/\tau_{cls})^{1/3}$ scaling at long mixing times and shows a plateau in the fast mixing regime, exactly as the theory predicts.

Note, that the NP size in Fig. 3 is completely determined by the kinetics and is not related to the equilibrium diblock copolymer micelle size. Indeed the latter would depend solely on the molar mass, composition, and solvent

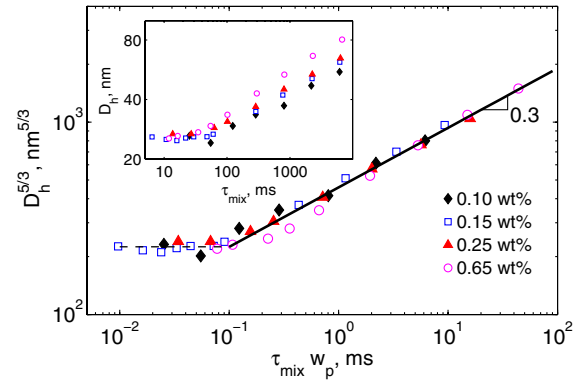

FIG. 3 (color online). Master curve of the size of the core of the diblock copolymer NPs vs the rescaled mixing time, following the scaling predicted by (6). Inset: The original data from Johnson and Prud'homme [7].

quality, whereas the NP size is a strong function of concentration. Although the NP system is not in a thermodynamic equilibrium, it is long-lived. As an x-ray study on a somewhat different diblock copolymer system shows [16], micellization of copolymers includes two stages. The first rapid stage is totally controlled by kinetics and leads to the NP formation described in the present work. The second, a several orders of magnitude slower process, drives the NP system to the thermodynamic equilibrium.

Based on the experimental evidence discussed above, one can conclude that the nanoprecipitation model based on a diffusion limited coalescence mechanism adequately describes the NP formation process. Two relevant time scales, the mixing and the encounter and coalescence times, are identified in (6) and their ratio is shown to be of a critical importance for the NP final diameter. The latter is predicted to scale in a universal manner and be sensitive predominantly to the mixing time and the polymer concentration if the surfactant concentration is sufficiently high. The molar mass of the carrier polymer is shown to have little influence. Experimental data available corroborate the predictions of our model and provide a solid framework for tailoring NPs with *a priori* determined size thus avoiding a laborious trial and error approach.

We thank Professor R. Prud'homme for useful discussions.

- [1] T. Kietzke, D. Neher, K. Landfester, R. Montenegro, R. Güntner, and U. Scherf, *Nature Mater.* **2**, 408 (2003); D. Peer, J. M. Karp, S. Hong, O. C. Farokhzad, R. Margalit, and R. Langer, *Nature Nanotech.* **2**, 751 (2007); H. Koo, M. S. Huh, I.-C. Sun, S. H. Yuk, K. Choi, K. Kim, and I. C. Kwon, *Acc. Chem. Res.* **44**, 1018 (2011).
- [2] S. Galindo-Rodriguez, E. Allémann, H. Fessi, and E. Doelker, *Pharm. Res.* **21**, 1428 (2004).
- [3] L. C. Katz, A. Burkhalter, and W. J. Dreyer, *Nature (London)* **310**, 498 (1984).

- [4] M. Akbulut, P. Ginart, M.E. Gindy, C. Theriault, K.H. Chin, W. Soboyejo, and R.K. Prud'homme, *Adv. Funct. Mater.* **19**, 718 (2009).
- [5] T. Niwa, H. Takeuchi, T. Hino, N. Kunou, and Y. Kawashima, *J. Control. Release* **25**, 89 (1993).
- [6] J. Molpeceres, M. Guzman, M.R. Aberturas, M. Chacon, and L. Berges, *J. Pharm. Sci.* **85**, 206 (1996).
- [7] B.K. Johnson and R.K. Prud'homme, *Phys. Rev. Lett.* **91**, 118302 (2003).
- [8] S. Stainmesse, A.-M. Orecchioni, E. Nakache, F. Puisieux, and H. Fessi, *Colloid Polym. Sci.* **273**, 505 (1995).
- [9] T. Chen, A.-P. Hynninen, R.K. Prud'homme, I.G. Kevrekidis, and A.Z. Panagiotopoulos, *J. Phys. Chem. B* **112**, 16357 (2008).
- [10] J.C. Cheng and R.O. Fox, *Ind. Eng. Chem. Res.* **49**, 10651 (2010).
- [11] D. ben-Avraham, *Phys. Rev. Lett.* **81**, 4756 (1998).
- [12] M. von Smoluchowski, *Z. Phys. Chem., Abt. A* **92**, 129 (1917); N. Dorsaz, C. De Michele, F. Piazza, P. De Los Rios, and G. Foffi, *Phys. Rev. Lett.* **105**, 120601 (2010).
- [13] J. Keizer, *J. Chem. Phys.* **86**, 5052 (1982); J. Keizer, *Chem. Rev.* **87**, 167 (1987).
- [14] We consider here only the fast agglomeration process leading to a kinetically frozen stabilized suspension. Slow processes, such as Ostwald ripening, set in only afterwards and control the stability of the dispersion. See also Y. Liu, K. Kathan, W. Saad, and R.K. Prud'homme, *Phys. Rev. Lett.* **98**, 036102 (2007).
- [15] M. Daoud and J.P. Cotton, *J. Phys. (Paris)* **43**, 531 (1982).
- [16] R. Lund, L. Willner, M. Monkenbusch, P. Panine, T. Narayanan, J. Colmenero, and D. Richter, *Phys. Rev. Lett.* **102**, 188301 (2009).