

Acceleration assisted tracking control

Citation for published version (APA):

Jager, de, A. G. (1994). Acceleration assisted tracking control. *IEEE Control Systems Magazine*, 14, 20-27.
<https://doi.org/10.1109/37.320883>

DOI:

[10.1109/37.320883](https://doi.org/10.1109/37.320883)

Document status and date:

Published: 01/01/1994

Document Version:

Publisher's PDF, also known as Version of Record (includes final page, issue and volume numbers)

Please check the document version of this publication:

- A submitted manuscript is the version of the article upon submission and before peer-review. There can be important differences between the submitted version and the official published version of record. People interested in the research are advised to contact the author for the final version of the publication, or visit the DOI to the publisher's website.
- The final author version and the galley proof are versions of the publication after peer review.
- The final published version features the final layout of the paper including the volume, issue and page numbers.

[Link to publication](#)

General rights

Copyright and moral rights for the publications made accessible in the public portal are retained by the authors and/or other copyright owners and it is a condition of accessing publications that users recognise and abide by the legal requirements associated with these rights.

- Users may download and print one copy of any publication from the public portal for the purpose of private study or research.
- You may not further distribute the material or use it for any profit-making activity or commercial gain
- You may freely distribute the URL identifying the publication in the public portal.

If the publication is distributed under the terms of Article 25fa of the Dutch Copyright Act, indicated by the "Taverne" license above, please follow below link for the End User Agreement:

www.tue.nl/taverne

Take down policy

If you believe that this document breaches copyright please contact us at:

openaccess@tue.nl

providing details and we will investigate your claim.

Acceleration Assisted Tracking Control

Bram de Jager

This paper discusses the use of acceleration measurements to improve the performance and robustness of controllers for mechanical systems. To use acceleration signals there are at least two approaches: direct use in a feedback loop to improve the tracking error, and indirect use by an observer to improve the estimates of position and speed.

Several proposals for the use of the acceleration in a feedback loop, resulting in slightly different controllers, are discussed. The design of the controllers for the experimental system, a flexible multiple degrees-of-freedom XY-table, uses a simplified two degrees-of-freedom model. The observer is of the predictive type to compensate for the time delay in the implementation, and its design is based in part on Kalman filter theory.

Simulations and experiments show that both acceleration feedback and an acceleration assisted observer can improve the performance of the control system, but the robustness does not change significantly. A combination of both approaches did not give any improvement in the experiments, but some in the simulations. Disturbances in the acceleration signal (especially motor torque ripple), phase lag introduced by the signal processing equipment, time delay caused by the sampled data implementation of the controller and observer, and the non collocated position and acceleration sensors are believed to be limitations for the usefulness of the acceleration signal. A performance improvement up to a factor of 1.5 was possible in our application, so to consider the use of acceleration measurements in tracking control is recommended.

Introduction

The use of acceleration measurements may improve the tracking performance of controlled mechanical systems. We distinguish two approaches. The first is a *direct* approach, where the acceleration signal is used directly in some kind of feedback loop to improve the robust performance. In the *indirect* approach, the signal is used indirectly in an observer, estimating the manipulator degrees-of-freedom and their derivatives, to improve the estimates of position and speed, i.e., reduce the contamination with noise by filtering the measurements, or raise the bandwidth of the measured signals. Other attractive properties of acceleration measurements are

1. it can replace more expensive "non structure mounted" sensors
2. low cost, e.g., by using acceleration devices with accelerometers integrated on chip
3. the sensor can be easily attached to the structure.

A version of this article was presented at the 1993 IEEE International Conference on Systems, Man, and Cybernetics. The author is with the Stevin Center at the Faculty of Mechanical Engineering, Eindhoven University of Technology, P.O. Box 513, 5600 MB Eindhoven, The Netherlands. Email: jag@wfv.wtb.tue.nl.

A disadvantage of acceleration feedback is the introduction of an algebraic loop due to the direct feedthrough of the input torque to the acceleration measurement. To break this loop a filter or time delay is needed. The influence of the filter and the time delay should be not too large so as not to negate the profits from acceleration feedback. Because the controller implementation will be a sampled data one needing presampling filters and causing time delay in the loop, the algebraic loop does not pose an additional problem, but the profitability of acceleration feedback needs further study. Our use of acceleration measurements in mechanical control systems aims at improving the performance (smaller tracking errors) and the robustness for model errors. Robustness is the ability to withstand variations in the loop components (plant and controller) or errors in the model used in the control design. The robustness criterion may be stability or performance.

The principal theme of the paper is an assessment and discussion of the usefulness of acceleration measurements in the robust control of mechanical systems.

This theme has already been discussed by several authors. In [1], [2] acceleration is used to counteract the effects of uncertainty in the inertia matrix. Other types of model errors are not addressed. They modify a standard computed torque controller and compare several proposals for selecting some weight factors in this modification. Their results show that optimal selected factors give the smallest tracking errors compared with a standard computed torque controller. Slotine [3] hints at the use of an additional acceleration error feedback and gives an expression for the reduction of the tracking error in the presence of measurement errors. He adds a term, proportional with the first and second derivative of the tracking error, to the control input signal of a standard adaptive computed torque like controller, later discussed in [4] and claims a reduction of the influence of parametric uncertainty on performance. This reduction is bounded by the influence of measurement noise. Heeren [5] proposes to use the acceleration to reduce the equation error, a measure for the model uncertainties. Here, the controller output is a linear combination, with suitable chosen factor, of the output of a lower level controller and the acceleration. It reduces the equation error in the presence of model errors and not otherwise. For certain types of lower level controllers, this modification also gave a reduction of the tracking error, related to the size of the factor. Another approach, and an alternative for model-based control, is to use a simple linear PDD controller based on position measurements only [6]. Here, the acceleration is obtained by numerical differentiation. This only gives good results for high sampling rates (≈ 5 [kHz]) and the quantization error of the position measurement has to be small. The effect of collocated acceleration feedback on the stability of flexible structures is analyzed in [7]. Experimental results for acceleration feedback are presented by, e.g., [8-14].

The use of acceleration signals to improve the estimates of position and velocity, by filtering the signals to reduce the contamination with noise and disturbances, or by raising the bandwidth of the signals, has also been proposed earlier, see, e.g., [8].

An assessment of several of these proposals and a discussion of their relative merits, i.e., potential benefits and limitations, is the aim of this research.

The next section gives a more thorough description of the control schemes investigated. Then, we discuss the experimental system and its design and simulation model. The following section presents and discusses the simulation and the experimental results. Finally, the last section contains the conclusions and recommendations. Some additional details are in the appendix.

Control Schemes

This section contains an overview of several control schemes. Some schemes are based on an adaptive computed torque like controller, proposed by Slotine and Li [4]. This scheme does not use acceleration feedback and is used, without an adaptation component, as a reference. Main emphasis is on a scheme that uses the acceleration according to the proposal of Heeren [5].

The system to be controlled is modeled by the following set of nonlinear equations of motion in m degrees-of-freedom q

$$M(q, \theta) \ddot{q} + C(q, \dot{q}, \theta) \dot{q} + g(q, \dot{q}, \theta) = f \quad (1)$$

where $M(q, \theta)$ is the $m \times m$ positive definite inertia matrix with model parameters θ , $C(q, \dot{q}, \theta) \dot{q}$ is the m vector of Coriolis and centripetal forces, $g(q, \dot{q}, \theta)$ the m vector of gravitational forces, Coulomb, and viscous friction, and f the m vector of generalized control forces. In this model each degree-of-freedom has its own motor. Here, we neglect the dynamics of the motors, sensors, and amplifiers, and the influence of stiction, backlash, and flexibility of the joints and links.

The passivity based control scheme of Slotine and Li consists of an approximate feedforward component, based on an estimate of the manipulator dynamics and a virtual reference trajectory, and a PD component, resulting in

$$f = \hat{M}(q) \ddot{q}_r + \hat{C}(q, \dot{q}) \dot{q}_r + \hat{g}(q, \dot{q}) + K_v s \quad (2)$$

where $\hat{M} = M(q, \hat{\theta})$, $\hat{C} = C(q, \dot{q}, \hat{\theta})$, and $\hat{g} = g(q, \dot{q}, \hat{\theta})$ are the same as the corresponding terms in (1) with $\hat{\theta}$ an estimate of the model parameters, $\dot{q}_r = \dot{q}_d + \Lambda \tilde{q}$ a virtual reference trajectory, $s = \dot{\tilde{q}} + \Lambda \tilde{q}$ a measure of tracking accuracy, $\tilde{q} = q_d - q$ the tracking error, and $q_d(t)$ the desired trajectory. The control parameters are K_v and Λ .

The component $K_v s$ is a genuine PD control, because it is equal to $K_v (\dot{\tilde{q}} + \Lambda \tilde{q}) = K_v \dot{\tilde{q}} + K_p \tilde{q}$ with $K_p = K_v \Lambda$. Putting the PD component in this form makes it easy to extend the class of controllers for the tracking error from PD to, e.g., sliding mode controllers, based on the sign of s . The measure of tracking accuracy s is used in the adaptation part of the controller also. The adaptive component of the control law is not used in this work, to simplify the interpretation of the results when using acceleration signals.

The modification proposed in [3] is to add a term $\alpha \dot{s}$ to the control input signal of (2). A reduction of the influence of

parametric uncertainty on performance is claimed by a factor $1 + \frac{\alpha}{\beta}$, with β the gain margin. A large α is needed to improve the tracking performance significantly. However, the influence of noise $n_{\ddot{q}}$ in the acceleration measurement will diminish this improvement. A relative error Δ_r in this measurement is claimed to have the same influence on tracking performance as a disturbance signal at the input of relative size $\frac{\alpha}{\alpha \beta + 1} \Delta_r$. For small α this influence is negligible ($\approx \alpha \Delta_r$), but for large α it is proportional with $\frac{\Delta_r}{\beta}$. To keep Δ_r small a good conditioning of the acceleration signal, by using filters, and an accurate sensor are necessary.

In [2] the standard computed torque control

$$f = \hat{M}(q) (v + \ddot{q}_d) + \hat{C}(q, \dot{q}) \dot{q} + \hat{g}(q, \dot{q}) \quad (3)$$

where v is the output of a linear, e.g., PD, controller is modified to

$$f = \hat{M}(q) (\beta I (v + \ddot{q}_d) - \alpha I \ddot{q}) + \hat{C}(q, \dot{q}) \dot{q} + \hat{g}(q, \dot{q}). \quad (4)$$

If the relative uncertainty $\gamma = \max_{q, \theta} \|M^{-1} \hat{M} - I\|$ in the mass matrix satisfies $\gamma < 1$, by a proper choice of \hat{M} , and if α is chosen to satisfy some stability requirement, they argue that the following choice for β ,

$$\beta = 2 \left(\frac{1 + \gamma}{1 + \alpha(1 + \gamma)} + \frac{1 - \gamma}{1 + \alpha(1 - \gamma)} \right)^{-1} \quad (5)$$

is optimal in the sense that it gives the largest reduction of the influence of errors in \hat{M} on the closed loop system equations. A simpler alternative is to choose $\beta = 1 + \alpha$ that corresponds to (5) for $\gamma \rightarrow 0$, as shown by the series expansion of β with respect to γ

$$\beta = 1 + \alpha + \frac{\alpha}{1 + \alpha} \gamma^2 + O(\gamma^4).$$

The acceleration can give an indication of the equation error, simply by filling in the measurements in the model equation. There are several ways to reduce the resulting residue, using acceleration feedback, as will be exemplified in the following. Define the equation error for (1) as

$$e = \hat{M}(q_m) \ddot{q}_m + \hat{C}(q_m, \dot{q}_m) \dot{q}_m + \hat{g}(q_m, \dot{q}_m) - f_m \quad (6)$$

where $q_m, \dot{q}_m, \ddot{q}_m$, and f_m are measurements that can be associated with q, \dot{q}, \ddot{q} , and f .

A simple method to reduce the equation error is using the acceleration as an additional input to the controller. If the new controller output is a linear combination, with suitable chosen factor, of the output of the original controller and the acceleration, the equation error can be reduced. The control force $f = f(q, \dot{q}, t)$, e.g., (2), can be extended to $f^* = f^*(q, \dot{q}, \ddot{q}, t)$ when acceleration measurements are available. As shown by [5], when the acceleration enters the feedback law as

$$f^*(q, \dot{q}, \ddot{q}, t) = (1 + \alpha)f(q, \dot{q}, t) - \alpha(\hat{M}(q)\ddot{q} + \hat{C}(q, \dot{q})\dot{q} + \hat{g}(q, \dot{q})) \quad (7)$$

it is possible to reduce the equation error e to

$$\frac{e}{1 + \alpha} \quad (8)$$

A large α may reduce the equation error considerably. A limitation is that the acceleration signal is contaminated with noise, see [3], and is fed back with some time delay. This limits the choice of α , e.g., $\alpha < 2/3$. Also relation (8) does not hold exactly, because it assumes that the unmodified equation error e (6) does not change. This assumption is not valid, because the position q proceeds along a slightly modified trajectory when using another feedback law.

Using in (7) the computed torque law (3), the resulting feedback law coincides with (4) for the choice $\beta=1+\alpha$. If (2) is used in (7) a slightly different controller results, \ddot{q}_r and $\hat{C}\dot{q}_r$ are used in (2) but in (3) \ddot{q}_d and $\hat{C}\dot{q}$ appear. Furthermore, the linear control component appears as $\hat{M}v$ and Kvs respectively. For a constant \hat{M} they can be made equal by proper choices for v , Kv , and Λ .

For controllers of the type (2) the equation error e appears as the only driving term in the tracking error dynamics, and its influence is reduced by the same factor $1+\alpha$, giving a reduction of the tracking error for $\alpha > 0$, when using (7). For other controllers, e.g., a PD control law, there are more driving terms in the tracking error dynamics and a more complex relation between α and the tracking error exists.

Based on the available literature, there is presently no readily available recipe to design the acceleration feedback gains. Relation (5) is only derived for errors in the mass matrix, certainly not the only type of model error encountered in practice, and it still contains the free parameter α . Guidelines for the use of acceleration in a more complex control scheme than a simple feedback loop (besides using it in a state estimator) are lacking also.

For the other approach investigated (the use of an acceleration assisted observer) a presentation of an observer for a general mechanical system (1) is not the purpose of this paper. This presentation is therefore omitted and we only comment that the design of the observer is based on a linear model, so standard techniques to design the gain, using Kalman filter theory, are available. The only complication is the direct feedthrough of the input torque to the acceleration measurements and the resulting process noise feedthrough. For this problem a solution is available. Because the standard assumptions used in Kalman filter theory are not satisfied, i.e., the process and measurement noise are not white and Gaussian, the filter gain matrix may need some detuning to be useful in practice, i.e., to get reasonable performance.

System and Models

The system studied is a 2D Cartesian manipulator (see Fig. 1) moving in the horizontal plane. It is a so-called TT-robot or, emphasizing the Cartesian coordinates, an XY-table. The table

consists of three prismatic joints, where two of the joints move parallel to each other and are coupled by a spindle with a torsion spring. This spring can be replaced easily, to change the stiffness of the spindle and by that changing the dynamics of the table. A rectangle slightly smaller than 1 [m²] is the area covered by the end-effector. Two current amplifiers feed two permanent magnet DC motors. The transmission consists of belt-wheels and belts with square teeth. The two belts that drive the x -slides, and by that the y -slideway, are connected to belt-wheels on the spindle. The spindle is connected to the x -motor by a belt with a reduction of ratio 60/13 to comply with the motor characteristics. The belt for the y -slide is connected to a belt-wheel directly mounted on the y -motor, so this motor drives the end-effector without reduction. Pre-tensioned springs connect the belts with the slides. These springs can be exchanged to introduce varying flexibility in the drive line. The nonmetallic belts are normally quite stiff, but after prolonged use they show small cracks that reduce their stiffness. In all the experiments a fixed set of springs and rather new belts was used. Only the torsion spring in the spindle was exchanged to introduce, or change the frequency of, additional dynamics. The XY-table frame is mounted on a 1 [m³] cubic base of concrete. Due to the flexibility in the spindle the system is not completely decoupled or linear. If the spindle is flexible, the y -slideway does not need to be perpendicular to the x -slideway, and it rotates. Also, friction is a dominant nonlinear effect.

The choice for this experimental system has two sides. On one hand, the system is not an open kinematic chain, has no revolute joints, is almost decoupled, has almost no inertia related nonlinearities and is thus linear except for friction. It is therefore atypical for articulated robots. On the other hand, it is almost directly driven, has considerable friction, is easy to modify, and is relatively simple, making interpretation of the results easier. That simplification is often necessary becomes evident from the practice to evaluate controllers only for a few degrees-of-freedom simultaneously, with the other ones locked to a fixed posture, in experiments with multiple degrees-of-freedom articulated robots. The XY-table is also typical for a class of manipulators used for measurements, tooling, or accurate placement tasks in one plane, e.g., for placement of chips on a printed circuit board, although its accuracy is low. Effects of friction, flexibility, and vibration are, on purpose, prominently present to ease the study of their influence on control system performance.

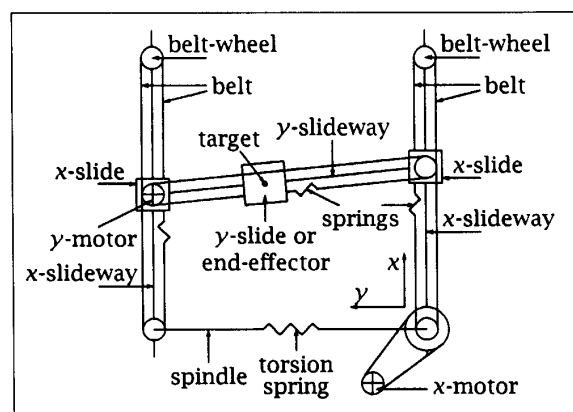

Fig. 1. Schematic drawing of XY-table.

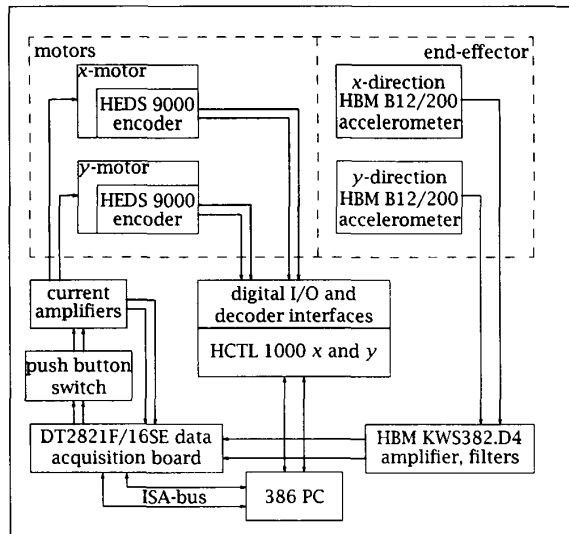

Fig. 2. Measurement and control system of XY-table.

There is thus no need for a costly system with expensive measurement devices to study these effects.

The measurement and control system configuration is presented in Fig. 2. Two encoder wheels mounted on the motor shafts provide position information. Lined up with the x and y axis of the end-effector, two accelerometers measure its acceleration. They are connected to a signal amplifier. To eliminate high frequency noise and disturbances, and to increase the signal-to-noise ratio, it was necessary to, quite elaborately, filter the measured acceleration with low pass filters. Several filters are available, e.g., low pass Butterworth filters with cut-off frequencies of 1 [kHz] and 10 [Hz], and first order filters with cutoffs of 40 [Hz]. The first order filters, simple RC-circuits, were inserted between the amplifier and the AD converter. They function as presampling filters to avoid aliasing and are therefore always used. The Butterworth filters are incorporated in the signal amplifier, and can be switched easily. It was therefore possible to obtain an acceleration signal effectively filtered at 40 [Hz], by using the 1 [kHz] Butterworth filter, or at 10 [Hz]. Normally the setting giving a 40 [Hz] filtered signal was used. Using the other setting will be indicated explicitly.

A data acquisition board, containing analog and digital IO terminals, and the parallel port interface with the experiment. The software for the sampled data control system implementation runs on PC-class hardware. C++ with a matrix object class is the programming language. A standardized library is available, taking care of the interfacing, scaling, etc. It also provides for safeguarding of the experimental system.

For the design computations and for the model based controller a simple two degrees-of-freedom model of the XY-table has been used. The equations for this model are

$$\theta_1 \ddot{x} + \theta_3 \operatorname{sgn} \dot{x} = f_x$$

$$\theta_2 \ddot{y} + \theta_4 \operatorname{sgn} \dot{y} = f_y$$

where x and y , the coordinates of the end-effector, are the degrees-of-freedom q , f_x and f_y the control forces in x and y direction, and θ_i , $i = 1, \dots, 4$, the model parameters: θ_1 and θ_2 are the equivalent masses in x and y direction, θ_3 and θ_4 are the coefficients of the Coulomb friction. Coriolis and centrifugal forces are absent because in a two degrees-of-freedom model there is no coupling between movements in x and y direction. Gravitational forces are absent also, because the manipulator moves in the horizontal plane. For the nominal parameter values used in the design see Table 1.

Table 1: Nominal parameters of the XY-table design model

Parameter	Value	Unit
$\hat{\theta}_1$	46.5	kg
$\hat{\theta}_2$	4.3	kg
$\hat{\theta}_3$	50.0	N
$\hat{\theta}_4$	15.0	N

A more involved model of the XY-table, the evaluation model, based on a complicated model developed in [15], has been used for the simulations. For its elaboration see the appendix. It is a three degrees-of-freedom model, including provisions for motor torque ripple, sensor quantization, input quantization and saturation, and also Coulomb, viscous, and position dependent or periodic friction [16]. It does not include the full nonlinearity of the model in [15]. Furthermore, it does not account for the flexibility of the belts, of the springs connecting belts and slides, and of the frame. Also, the lowest table-base-floor vibration mode can be excited in practice, but this mode is not present in the simulation model.

The simulation model used is just a plug-in replacement for the experimental system. The sampled data controller implementation for the simulations and the experiments is therefore the same. Linking with another software library is the only difference between making an executable for simulations or experiments.

Results and Discussion

The acceleration feedback and the observer are evaluated by means of simulations and experiments with the XY-table. The design of the controllers and observer is based on the simplified two degrees-of-freedom model. Using such a simplified model, compared with the more complex real system, enables us to draw conclusions with respect to the improvement of robustness of the control system.

Four controller schemes were coded in the control program: (2) with the additional $\alpha \dot{s}$ term, the combinations of (7) and (2) or (3), and (4). The controller (4) is identical with the combination of (7) and (3) if $\gamma=0$, because then $\beta=1+\alpha$.

In the following we will only present results obtained with the controller (7) using the computed torque law (3) as the basic controller. The results with (2) were essentially the same. Slotine's modification of (2) did not give results as good as the others.

For the linear control input v in (3) we choose $\hat{M}^{-1} K_v s$ with $K_v s$ from (2). This choice for v makes sense if the mass matrix is

constant and it assures identical tuning for the PD part of the control schemes. The controller parameters K_v and Λ are designed to achieve a response of a reference second order system with specified damping β_0 and undamped natural frequency ω_0

(or f_0 in [Hz]), so $K_v = 2 \beta_0 \omega_0 \hat{M}$ and $\Lambda = \frac{\omega_0^2}{2 \beta_0}$. In the XY-table

controller $\beta_0=0.7$ and $f_0=4$ [Hz] were used for both x and y motor control in most cases. Exceptions to this rule are indicated explicitly. An undamped natural frequency of 4 [Hz] corresponds with a closed loop bandwidth of approximately 8 [Hz].

An observer to estimate the position and velocity, and with a simple friction correction term to eliminate the friction compensation force, was added. The observer first applies a measurement update to the states (filtering), and then a time update over one sample using the nominal model (prediction). Normally, the states after the measurement update are used for control. Here, the controller is implemented as a sampled data system, with a nominal sample time of 7 or 5 [ms]. For control the predicted states, after the time update, are used to compensate for the computational delay of exactly one sample time. A smaller delay is not possible due to the characteristics of the AD-converter that does not allow for intersampling activities. Normally, the observer uses the position measurements (in the measurement update) and the motor current (in the time update) to estimate position and speed. In addition the acceleration can be used in the measurement update, but not in the time update.

In the following, an illustrative selection of simulation and experimental results is presented and discussed. Simulation results are included because they give additional insight by providing a larger range of parameter and unmodeled dynamics errors and by allowing larger values of α . We remark beforehand that some experimental results are inconsistent. This is due to changes in the experimental conditions between experimental sessions (modifications, maintenance, wear and tear). The results within a single figure are not hampered by this, because they were obtained within a single session.

The control task was to track a circle several times. The speed along the trajectory is chosen so the inertia and friction forces are of the same order of magnitude. The measure of tracking accuracy used is the mean absolute tracking error (MATE) over all but the first complete circle, so initial transient effects are basically excluded.

The evaluation of the controllers uses three criteria: nominal performance, parameter robustness, and unmodeled dynamics robustness. The desired robustness properties should be reflected in low sensitivity for parameter errors and unmodeled dynamics. The table contains several options to manipulate parameter errors or unmodeled dynamics. Two of them are used: mass variation of the end-effector and different torsion springs in the spindle. Nominal performance is evaluated for the normal system setup, parameter robustness by changing the end-effector mass, and unmodeled dynamics robustness by introducing flexibility in the system. Because variations in the end-effector mass are relatively larger for the y -direction, results for this direction alone are presented. Variations in stiffness of the torsion spring mainly influence the x -direction, so only those results are given.

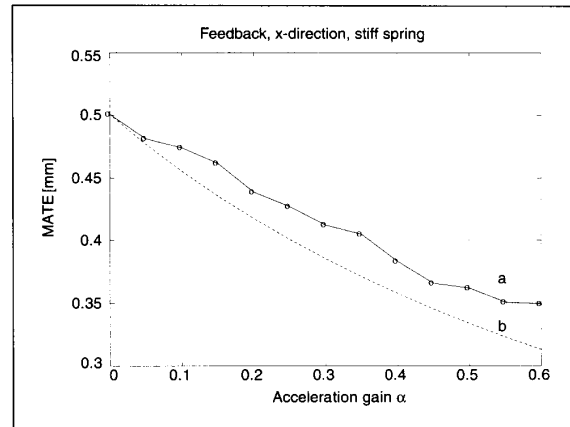

Fig. 3. Relation between α and tracking error; a: experiment, b: equation (8).

Acceleration Feedback

In theory, the performance increase for acceleration feedback depends, by the fraction like function (8), on the gains α . In practice, these gains cannot be increased much, even if the torsion spring is stiff. Experimental results for the x -direction show this in Fig. 3 for the most rigid torsion spring, representing the nominal case.

For increasing values of α the difference between theory and practice increases. If $\alpha > 0.6$ the system becomes unstable. For this case performance data cannot be generated due to safe guarding of the experimental system. Contamination with noise and disturbances of the acceleration signal (e.g., due to motor torque ripple and dry friction variations), time delay in the feedback, imperfect time update in the observer, and non collocated position and acceleration sensors (the position encoder is mounted on the motor shaft and the acceleration sensor on the end-effector) are the main limitations for high gains in the acceleration feedback loop, and therefore limit its usefulness. Because the torque generation and acceleration measurements

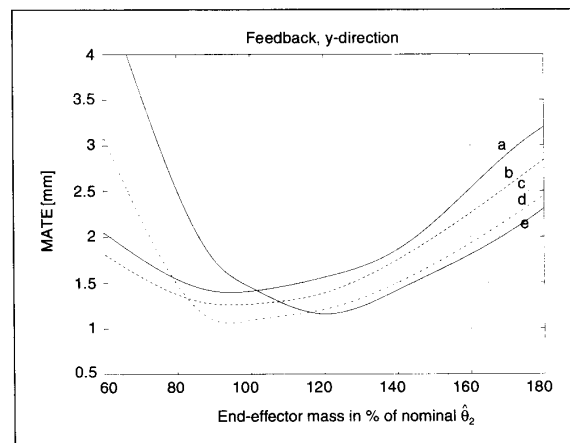

Fig. 4. Tracking error in y -direction; simulation a: $\alpha = 0$, b: $\alpha = 0.2$, c: $\alpha = 0.4$, d: $\alpha = 0.6$, e: $\alpha = 0.8$.

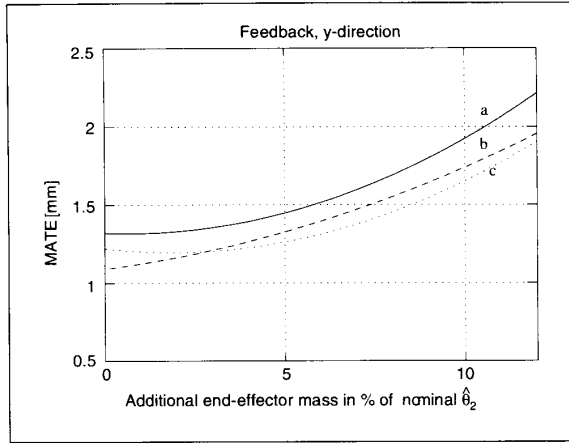

Fig. 5. Tracking error in y-direction; experiment a: $\alpha = 0$, b: $\alpha = 0.3$, c: $\alpha = 0.4$.

are also non collocated, the stability properties for the collocated situation, derived in [7], are not applicable.

Figures 4-5 show the influence of parameter errors in the end-effector mass on tracking error performance for several values of the gain α . Fig. 4 gives the simulation tracking error where in the simulation model the mass of the end-effector is changed. The simulation model mass, as % of the nominal value $\hat{\theta}_2$, is listed. Fig. 5 presents the equivalent experimental results. Because in the experiment mass can only be added to, and not removed from, the end-effector, the added mass, in % of the nominal mass $\hat{\theta}_2$, is listed. In the experiment mass can be added in small quantities only, limiting the range of the parameter errors.

In both cases the tracking error is reduced for appropriate values of α . The relative increase of the tracking error for end-effector mass variations does not change significantly between different values of $\alpha \leq 0.4$, so the gain in robustness is limited. Compared with the simulations, in the experiments the tracking error deteriorates faster for increasing parameter error.

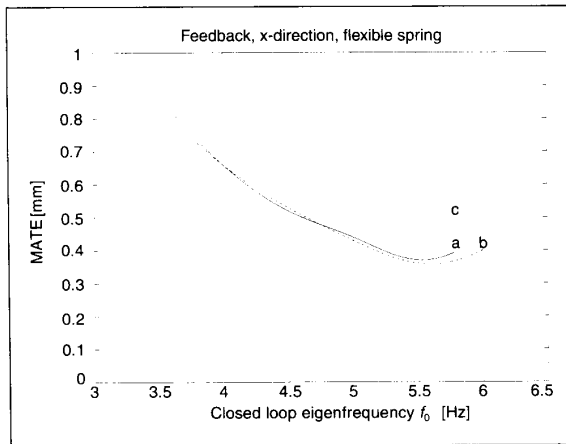

Fig. 6. Tracking error in x-direction; experiment a: $\alpha = 0$, b: $\alpha = 0.4$, c: $\alpha = 0.6$.

One cause is the friction that does not change with variations in mass for the simulations while in the experiments the end-effector mass has a direct influence on the Coulomb and viscous friction forces in y-direction.

The influence of the torsion spring stiffness, i.e., a change in the unmodeled dynamics, is shown in Fig. 6. The MATE is given as a function of closed loop eigenfrequency (determined by K_V and Λ) that is not fixed to $f_0=4$ [Hz] now, and for three values of α . No results are available for larger f_0 than presented, due to chattering of at least one of the input signals. The most flexible spring was used, thereby decreasing the stiffness by almost three orders of magnitude compared with the stiff spring.

Here, the usefulness of acceleration feedback is not evident. The performance measure is quite insensitive for acceleration feedback when the spring is flexible, but the stability is impaired for larger eigenfrequencies, and for $\alpha=0.6$ this happens earlier, so the robustness for unmodeled dynamics is not improved.

From these simulations and experiments it becomes clear that acceleration feedback, as proposed in [5] can improve the performance of the control system. The parameter and unmodeled dynamics robustness does not change significantly, however.

Acceleration feedback complicates the control algorithm. This should be weighted against a possible increase of the sampling rate, often an effective method to reduce the tracking error. Increasing the sampling rate has at least three effects: it reduces the prediction errors of the observer, the input f can be changed more frequently, and in addition the time skew of the acceleration measurements (that are not predicted one sample ahead) is reduced. The effect is shown in Fig. 7.

Both measures increase the tracking performance, but it appears that acceleration feedback is more profitable than an increased sampling rate. It should therefore be preferred if one is forced to choose one or the other.

Acceleration Based Observer

The use of the acceleration signal in an observer makes it possible to obtain a more accurate estimate of, especially, the velocities. The positions can also profit, but they are already measured with high accuracy by the optical encoders, errors are

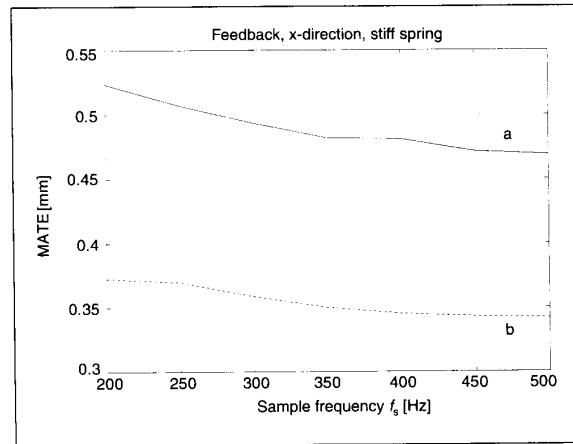

Fig. 7. Relation between sampling rate and tracking error; experiment a: $\alpha = 0$, b: $\alpha = 0.4$.

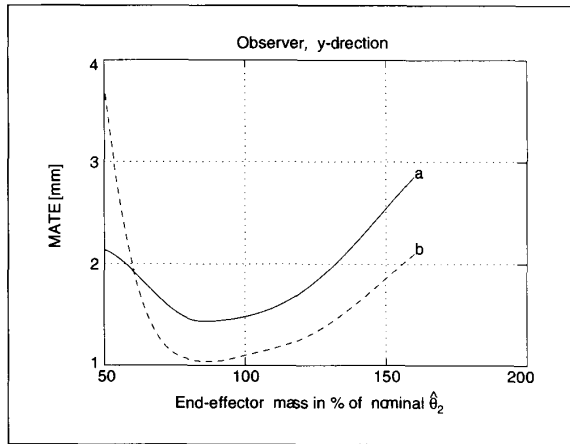

Fig. 8. Tracking error in y -direction; simulation a : without, b : with acceleration assisted observer.

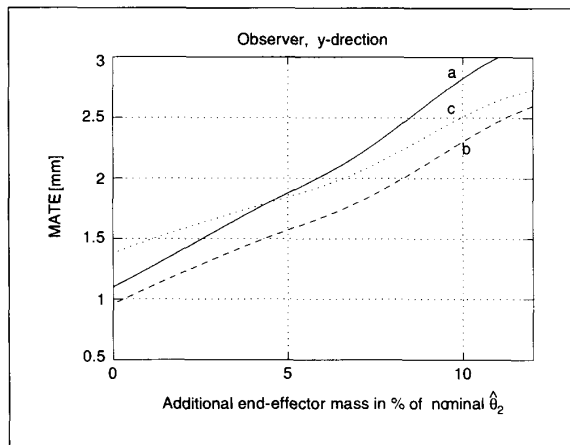

Fig. 9. Tracking error in y -direction; experiment a : without acceleration, b : with acceleration filtered at 40 [Hz], c : with acceleration filtered at 10 [Hz].

introduced in the prediction only. An additional advantage is the improved bandwidth of the velocity signal estimate. This results in an improvement of the tracking error, for both simulations and experiments, see Figs. 8-9.

Fig. 8 presents simulation results with and without an acceleration assisted observer as a function of the end-effector mass used in the simulation model. No high frequency noise is added to the acceleration signal, so filtering is not necessary. An acceleration assisted observer does a better job, except for very small values of the mass. In Fig. 9 equivalent experimental results are shown, but only for positive variations in end-effector mass. Here, not only a filter for the acceleration signal with a bandwidth of 40 [Hz] was used, but also one with 10 [Hz] bandwidth. The results with filtering at 40 [Hz] are significantly better, which was the reason this setting was used in all other experiments. The improvement then is of the same order as obtained with acceleration feedback for $\alpha = 0.4$, see Fig. 5.

When the torsion spring is flexible—so evaluating the performance in x -direction—the advantage of using acceleration assisted observers vanishes, like for the acceleration feedback. The improvement of the robustness for unmodeled dynamics is therefore not significant, just as for the acceleration feedback approach, and for similar reasons.

Acceleration Feedback and Observer Combined

The combined use of the acceleration in both a feedback loop and an observer did show to be profitable in simulations, yet not in practice. This is due to impaired stability, that made a lower closed loop eigenfrequency f_0 necessary. Since in our case the separation theorem is not valid, because of the nonlinearity of the system and the unmodeled dynamics, this is not unexpected.

The stability problem is attributed to the frequency contents of the input signals, in our case the torque commands to the drives. Closer observation showed that when both approaches are used these signals contain fairly large high frequency components that may excite, and at the same time may be the results of, unmodeled dynamics. An additional filtering of the input signal, except for the friction compensation part, could not remedy the results of this phenomenon, due to the causality of the filter and the corresponding additional phase shift. A thorough explanation for the above mentioned observation is not available and will be looked for in the future. Although there is no evidence of improved performance, indeed, the contrary, there is at the moment no substantial reason why combining both approaches should hurt performance.

Conclusions and Recommendations

The trend to avoid, at all costs, the use of acceleration measurements (e.g., evident in the adaptive control of robots, where it is stated to be an advantage not to use the acceleration explicitly in the control scheme) does not seem to be appropriate. The acceleration can improve the tracking performance, it is also relatively easy and straightforward to measure, and the measurement can be done by structure mounted devices. An increase in tracking accuracy by a factor of 1.5 may be possible in practice. Using acceleration feedback is also more effective than an increase in the sampling rate.

We therefore recommend to consider the use of acceleration feedback, or of acceleration assisted observers. We hesitate to recommend using the two approaches together, but the lack of increased performance in this case may be due to our specific system and its associated higher frequency dynamics. An accurate and clean acceleration signal is needed to be useful, so a high accuracy sensor is necessary and filters should be used to increase the signal-to-noise ratio, without adding too much phase shift.

The results obtained for the XY-table are expected to be indicative of the results for articulated robots. To verify this expectation, experiments on a system with revolute joints and significant inertia related nonlinearities are needed. At our laboratory, a system suited for these experiments is in the commissioning stage.

Acknowledgment

The author would like to thank Rob Visser for his contribution to the simulations and experiments.

Appendix

The evaluation model used in the simulation program is based on a three degrees-of-freedom model in [15]. It is given by

$$M(q) \ddot{q} + h(q, \dot{q}) = Hf$$

where q_i , $i = 1, \dots, 3$, are the three degrees-of-freedom, q_1 is a displacement associated with the x -slide on the side of the spindle where the x -motor is located, q_2 with the y -slide, and q_3 with the x -slide on the side of the spindle away from the x -motor. This corresponds with

$$H = \begin{bmatrix} 1 & 0 \\ 0 & 1 \\ 0 & 0 \end{bmatrix}$$

For the simplified inertia matrix holds

$$M = \begin{bmatrix} m_{11} & 0 & m_{13} \\ 0 & m_{22} & 0 \\ m_{31} & 0 & m_{33} \end{bmatrix}$$

where

$$m_{11} = m_1 + m_2 (1 - \xi_2)^2 + \frac{1}{3} m_b$$

$$m_{31} = m_2 (1 - \xi_2) \xi_2 + \frac{1}{6} m_b$$

$$m_{22} = m_2$$

$$m_{13} = m_{31}$$

$$m_{33} = m_3 + m_2 \xi_2^2 + \frac{1}{3} m_b$$

with $\xi_2 = \frac{q_2}{l}$, l the length of the y -slideway between the x -slides, and m_b its inertia. The m_i , $i = 1, \dots, 3$ are the inertias directly associated with the three degrees-of-freedom q . The inertia matrix is simplified by not including the elements $m_{32} = m_{23}$, containing terms in $q_{13} = q_1 - q_3$. It also neglects the inertia of the motors.

For the Coriolis, the centrifugal, the torsion spring force with constant k , and the spindle damping with constant b holds

$$h = \begin{bmatrix} -2 m_2 (1 - \xi_2) \xi_2 \dot{q}_{13} + k q_{13} + b \dot{q}_{13} \\ 0 \\ -2 m_2 \xi_2 \dot{q}_{13} - k q_{13} - b \dot{q}_{13} \end{bmatrix}$$

where h is simplified by ignoring the element h_2 containing terms of higher order in \dot{q}_{13} . To the h_i , $i = 1, \dots, 3$, are also added Coulomb and viscous friction terms for the movement of the three slides along the slideways. Provisions for motor torque ripple, sensor quantization, and input saturation and quantization are included.

References

[1] F. Berlin, W.M. Grimm, and P.M. Frank, "On robot motion control with acceleration feedback," in *Proc. of the 2nd IFAC Symposium on Robot Control* (Karlsruhe, Germany), pp. 183-188, IFAC, Oxford: Pergamon Press, 1989.

[2] F. Berlin and P.M. Frank, "Optimale Beschleunigungsrückführung in Roboterregelkreisen," *Automatisierungstechnik*, vol. 39, pp. 121-128, Apr. 1991.

[3] J.-J.E. Slotine, "On modeling and adaptation in robot control," in *Proc. of the 1986 IEEE Internat. Conf. on Robotics and Automat.*, vol. 3, (San Francisco, California), pp. 1387-1392, IEEE, Silver Spring, MD: IEEE Computer Society Press, Apr. 1986.

[4] J.-J.E. Slotine and W. Li, "Adaptive manipulator control: A case study," *IEEE Trans. Automat. Control*, vol. AC-33, pp. 995-1003, Nov. 1988.

[5] T. Heeren, *On Control of Manipulators*. PhD dissertation, Eindhoven University of Technology, Fac. of Mechanical Engineering, Apr. 1989.

[6] P. Chiacchio, F. Pierrot, and B. Siciliano, "Experimenting acceleration feedback loop for robot control," in *Proc. of the second European Control Conf.* (J.W. Nieuwenhuis, C. Praagman, and H.L. Trentelman, eds.), vol. 2 (Groningen, The Netherlands), pp. 565-569, June 1993.

[7] E. Sim and S.W. Lee, "Active vibration control of flexible structures with acceleration feedback," *J. Guidance, Control, and Dynamics*, vol. 16, pp. 413-415, Mar.-Apr. 1993.

[8] F.R. Shaw and K. Srinivasan, "Bandwidth enhancement of position measurements using measured acceleration," *Mech. Systems Sign. Procc.*, vol. 4, pp. 23-38, Jan. 1990.

[9] P.T. Kotnik, S. Yurkovich, and Ü. Özgüner, "Acceleration feedback for control of a flexible manipulator arm," *J. Robotic Systems*, vol. 5, pp. 181-196, June 1988.

[10] K. Aruga, Y. Mizoshita, M. Iwatsubo, and T. Hatagami, "Acceleration feedforward control for head positioning in magnetic disk drives," *JSME Internat. J., Series III*, vol. 33, no. 1, pp. 35-41, 1990.

[11] J.E. McInroy and G.N. Saridis, "Acceleration and torque feedback for robotic control: Experimental results," *J. Robotic Systems*, vol. 7, pp. 813-832, Dec. 1990.

[12] F. Matsuno and Y. Sakawa, "A simple model of flexible manipulators with six axes and vibration control by using accelerometers," *J. Robotic Systems*, vol. 7, pp. 575-597, Aug. 1990.

[13] Y. Hori and T. Uchida, "Proposal of a novel motion control method based on acceleration control," *Electr. Engrg. Japan*, vol. 110, no. 5, pp. 67-76, 1990.

[14] S. Futami, N. Kyura, and S. Hara, "Vibration absorption control of industrial robots by acceleration feedback," *IEEE Trans. Ind. Electronics*, vol. IE-30, pp. 299-305, Aug. 1983.

[15] M.J.G. van de Molengraft, *Identification of nonlinear mechanical systems: for control applications*. PhD dissertation, Eindhoven University of Technology, Fac. of Mechanical Engineering, Sept. 1990.

[16] B. de Jager, "Improving the tracking performance of mechanical systems by adaptive extended friction compensation," *Control Eng. Practice*, vol. 1, no. 6, pp. 1009-1018, 1993.



Bram de Jager received the Ir degree in Mechanical Engineering from Delft University of Technology and the Dr degree from Eindhoven University of Technology. He has been with Delft University of Technology and Stork Boilers (Hengelo, NL). Currently he is working at Eindhoven University of Technology. His active research interests are: robust control of nonlinear (mechanical) systems, application of symbolic computation in nonlinear control, nonlinear control structure design, and model based control of cogeneration plants.