

Integrated powertrain control for hybrid electric vehicles with electric variable transmission

Citation for published version (APA):

Kessels, J. T. B. A., Foster, D. L., & Bosch, van den, P. P. J. (2009). Integrated powertrain control for hybrid electric vehicles with electric variable transmission. In *Proceedings of the IEEE Vehicle Power and Propulsion Conference 2009, VPPC'09, 7-10 September 2009, Dearborn, Michigan* (pp. 376-381). Institute of Electrical and Electronics Engineers. <https://doi.org/10.1109/VPPC.2009.5289825>

DOI:

[10.1109/VPPC.2009.5289825](https://doi.org/10.1109/VPPC.2009.5289825)

Document status and date:

Published: 01/01/2009

Document Version:

Publisher's PDF, also known as Version of Record (includes final page, issue and volume numbers)

Please check the document version of this publication:

- A submitted manuscript is the version of the article upon submission and before peer-review. There can be important differences between the submitted version and the official published version of record. People interested in the research are advised to contact the author for the final version of the publication, or visit the DOI to the publisher's website.
- The final author version and the galley proof are versions of the publication after peer review.
- The final published version features the final layout of the paper including the volume, issue and page numbers.

[Link to publication](#)

General rights

Copyright and moral rights for the publications made accessible in the public portal are retained by the authors and/or other copyright owners and it is a condition of accessing publications that users recognise and abide by the legal requirements associated with these rights.

- Users may download and print one copy of any publication from the public portal for the purpose of private study or research.
- You may not further distribute the material or use it for any profit-making activity or commercial gain
- You may freely distribute the URL identifying the publication in the public portal.

If the publication is distributed under the terms of Article 25fa of the Dutch Copyright Act, indicated by the "Taverne" license above, please follow below link for the End User Agreement:

www.tue.nl/taverne

Take down policy

If you believe that this document breaches copyright please contact us at:

openaccess@tue.nl

providing details and we will investigate your claim.

Integrated Powertrain Control for Hybrid Electric Vehicles with Electric Variable Transmission

J.T.B.A. Kessels, D.L. Foster
TNO Science and Industry - Automotive,
P.O. Box 756, 5700 AT Helmond,
The Netherlands.

John.Kessels@TNO.nl, Darren.Foster@TNO.nl

P.P.J. van den Bosch
Technische Universiteit Eindhoven,
Dept. of Electrical Engineering,
P.O. Box 513, 5600 MB Eindhoven,
The Netherlands.

P.P.J.v.d.Bosch@TUE.nl

Abstract—The electric variable transmission (EVT) offers a powersplit for hybrid electric vehicles by integrating two motor/generator sets into one electric machine. This double rotor concept implements a continuously variable transmission between the engine and the driveline, including the possibility for electric propulsion.

To guarantee good energy efficiency of the overall vehicle configuration, an integrated powertrain control (IPC) strategy is developed. First, optimization of the transmission ratio is analyzed by considering energy losses in the EVT. Next, an energy management strategy is presented incorporating the complete hybrid functionality of the EVT. Simulation results demonstrate feasibility of this IPC strategy and support the design process for optimal component specifications.

I. INTRODUCTION

The hybrid electric vehicle (HEV) has become one of the most celebrated concepts for present and future transportation. Progressive developments in vehicle electrification, but also the advanced performance of new battery technologies have contributed to their reliable success. Now the automotive industry is challenged to develop vehicles with an even more efficient powertrain.

Well known are HEVs equipped with a powersplit using a planetary gear set to establish the mechanical connection between the internal combustion engine (ICE), the motor/generator (MG) sets and the vehicle driveline. Typically, the MG delivers propulsion power in such a way that the ICE operates in its preferred operating range. This so called electronic-continuously variable transmission (e-CVT) exists in different configurations, depending on the number of planetary gear sets used (see e.g. [10] for an extensive overview of possible e-CVT configurations).

Complementary to the e-CVT, full electric torque converters are nowadays also gaining interest [3]. By integrating two MGs into one electric machine with double rotor, an electric variable transmission (EVT) is constructed with no mechanical connection between the input and output shaft, see Fig. 1. The ICE and the driveline are mounted to these shafts, whereas power electronics are connected to both MGs. The battery storage device supplies the power electronics.

Depending on the applied technology, various concepts for the EVT are available. The concept presented by Hoeijmakers and TNO incorporates a highly integrated solution, involving

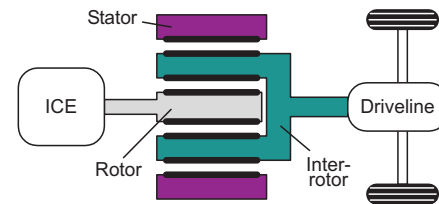

Fig. 1. Overview of vehicle drivetrain with EVT

two induction machines [6]. Nordlund and Eriksson presented a solution relying on two permanent magnet machines. These two machines are combined into one package, with the magnets of both machines mounted on the inter-rotor. Their concept is addressed in literature as Four Quadrant Transducer (4QT) [11]. Under financial support of the European Commission (FP6 framework), a similar solution is developed in the Hi-CEPS program (SP3000), incorporating two AC three phases mixed synchronous electric machines with buried permanent magnets. This hybrid active transmission is known as ElectroMagnetic CVT (EM-CVT) [1].

For proper operation of the EVT, integrated powertrain control (IPC) is required. This control strategy takes into account all components of the powertrain and offers a control strategy based on synergy between components [2]. IPC also includes energy management to obtain maximum energy efficiency for every driving cycle.

This paper presents an IPC solution for the EVT. First, Section II presents a strategy which considers the EVT without using the battery storage device. Next, a complete IPC strategy is presented incorporating energy management to optimize the energy exchange with the battery. Simulation results for this IPC strategy can be found in Section IV. Finally, the conclusions are summarized in Section V.

II. SYSTEM CONCEPT

The EVT can be considered as a powersplit device with two mechanical connections and two electrical connections. The mechanical connections are used by the engine and the driveline. The ICE delivers power P_{m1} [W] to the EVT, with engine speed ω_1 [rad/s] and torque τ_1 [Nm]. The driveline requests power P_{m2} [W] for vehicle propulsion. The direct

power throughput on the inter-rotor is addressed as P_t [W], see Fig. 2:

$$P_{m1} = \omega_1 \tau_1, \quad (1)$$

$$P_{m2} = \omega_2 \tau_2, \quad (2)$$

$$P_t = \omega_2 \tau_1. \quad (3)$$

In steady-state situations, the inner motor/generator (IM) is responsible for the transmission ratio ζ between the input and output shaft:

$$\zeta = \frac{\omega_1}{\omega_2} \quad [-]. \quad (4)$$

The external motor/generator (EM) directly applies propulsion torque to the output shaft, which is connected to the driveline. Altogether, both MGs can supply/retrieve additional power to/from the EVT to change the transmission ratio and bring the ICE to a desired operating point. The mechanical powerflow through the EVT is described by two power balances:

$$P_{m1} = P_t + P_{im}, \quad (5)$$

$$P_t = P_{m2} + P_{em}. \quad (6)$$

Conversion losses in the EVT are represented by one lumped efficiency for the IM and EM by means of η_{im} [-] and η_{em} [-], respectively. These efficiencies are calculated from experiments on a hardware-in-loop test-bench. A typical efficiency map for the IM and EM is shown in Fig. 3 and Fig. 4, respectively. There should be noted that these maps are measured independently: when measuring η_{im} there holds $P_{m1} = 0$ and when measuring η_{em} there holds $P_t = 0$. The net electric power leaving/entering the IM and EM is calculated as follows:

$$P_{c1} = \begin{cases} P_{im} \eta_{im_gen} & \text{if } P_{im} \geq 0 \\ P_{im} / \eta_{im_mot} & \text{if } P_{im} < 0 \end{cases}, \quad (7)$$

$$P_{c2} = \begin{cases} P_{em} \eta_{em_gen} & \text{if } P_{em} \geq 0 \\ P_{em} / \eta_{em_mot} & \text{if } P_{em} < 0 \end{cases}. \quad (8)$$

Each MG is connected to power electronics with corresponding power P_{c1} [W] and P_{c2} [W]. It is assumed that the power electronics have a constant efficiency $0 \leq \eta_c \leq 1$ [-] and to establish losses for positive and negative power, the max-operator is used:

$$P_{c1} = \max(\eta_{c1} P_{c1}, \frac{1}{\eta_{c1}} P_{e1}), \quad (9)$$

$$P_{c2} = \max(\eta_{c2} P_{c2}, \frac{1}{\eta_{c2}} P_{e2}). \quad (10)$$

The net electric power P_e [W] entails the sum of the power from the electric power converters and this power will be accumulated in the battery storage device:

$$P_e = P_{e1} + P_{e2}. \quad (11)$$

III. SYSTEM ANALYSIS

The EVT offers two degrees of freedom: the transmission ratio ζ and the net electric power P_e . These decision variables influence the energy efficiency of the hybrid powertrain and a suitable IPC strategy is desirable.

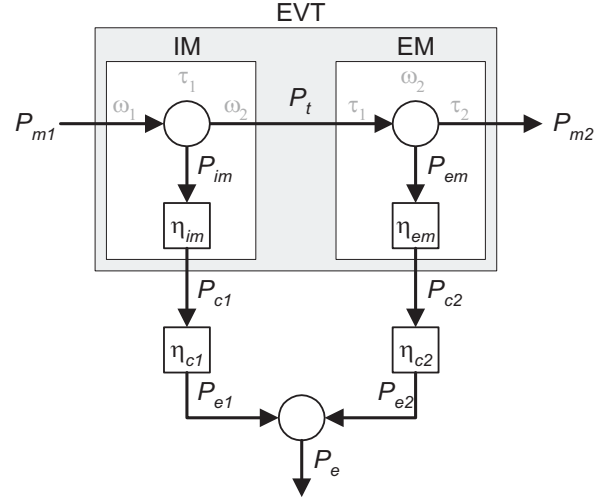

Fig. 2. EVT model with power converters

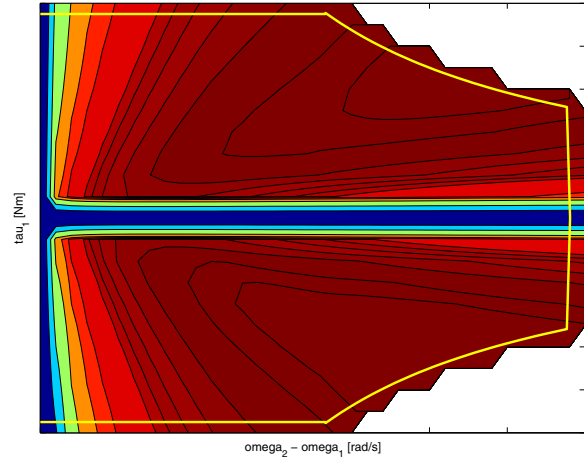

Fig. 3. Efficiency map of inner motor/generator (IM)

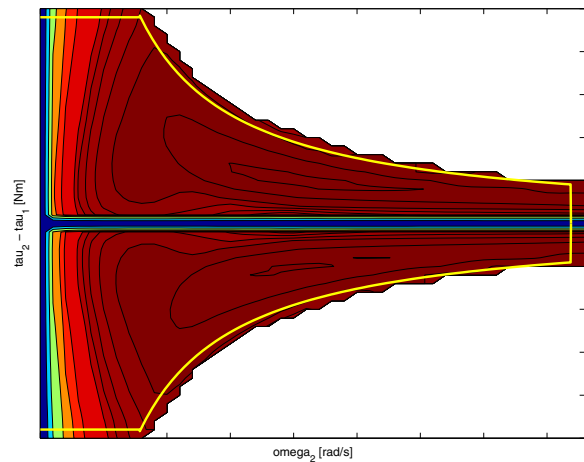

Fig. 4. Efficiency map of external motor/generator (EM)

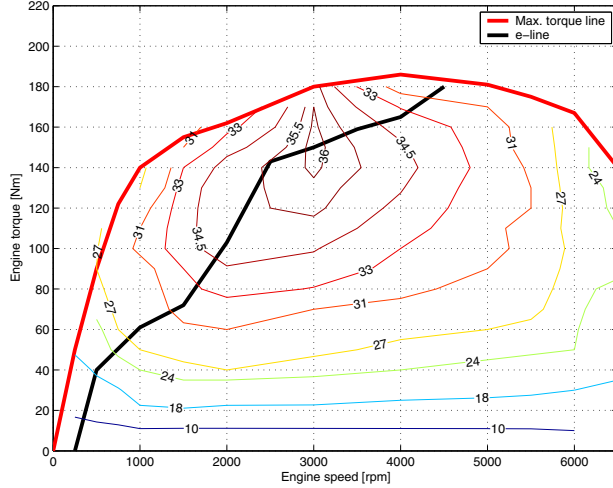

Fig. 5. Engine efficiency map η_{ice} with e-line

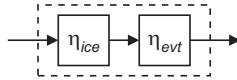

Fig. 6. IPC optimizes global energy efficiency

A. Transmission Ratio Optimization

The fuel consumption of the ICE plays an important role when selecting the transmission ratio and needs to be included for system analysis. Typically, the fuel mass flow F [g/s] of the ICE is available in terms of a look-up-table:

$$F(P_{m1}) = f(\omega_1, \tau_1) \quad [\text{g/s}]. \quad (12)$$

The ICE efficiency η_{ice} [-] is defined as the ratio between mechanical output power and chemical input power:

$$\eta_{ice} = \frac{P_{m1}}{P_{ch}} = \frac{\omega_1 \tau_1}{h_f f(\omega_1, \tau_1)}, \quad (13)$$

with h_f [J/g] the chemical energy content of fuel (i.e. lower heating value). For each power level P^* , there exists an engine operating point $(\omega_1, \tau_1)|_{P_{m1}=P^*}$ where the efficiency η_{ice} is maximized. The line connecting all these points describes the economy line (e-line), also referred to as optimal operating line. For a typical gasoline (spark ignition) engine, this e-line is visualized in Fig. 5, including the underlying efficiency map η_{ice} . The engine fuel use for this e-line will be denoted by $F_{e-line}(P_{m1})$ [g/s].

Historically, control strategies to optimize ζ focussed on e-line tracking, without paying attention to the efficiency of the transmission itself. IPC aims at control strategies which achieve a global optimal solution and therefore, η_{ice} as well as η_{evt} (=efficiency of EVT) have to be considered. This is elucidated in Fig. 6.

Depending on the vehicle speed profile, the EVT receives a power request P_{m2} from the wheels. According to the selected transmission ratio, this will lead to a power request

P_{m1} from the ICE. Remember that the IM from the EVT will be responsible for the engine speed, whereas the EM is responsible for the net engine torque. This mechanism is elucidated in Fig. 7. In case of no losses in the EVT and the power converters, it is rather trivial to calculate the transmission ratio where the ICE tracks the e-line for each power demand P_{m2} . Note that issues on driveability (e.g. ICE torque reserve) are not considered in this optimization approach.

Unfortunately, energy losses are always present in practical situations and it is not likely that the ICE purely operates on the e-line. This will be explained below.

It is important to recognize that the EVT and the power converters suffer from energy losses. The internal losses of the EVT (induced by η_{im} and η_{em}) are not proportional with power, and as such are sensitive to the transmission ratio. Allowing power through the power converters to change the transmission ratio introduces additional losses and this makes the overall efficiency even more sensitive to the transmission ratio. There can be concluded that the EVT itself achieves highest efficiency when $\zeta = 1$. Deciding whether it is profitable to change $\zeta \neq 1$ and bring the ICE on the e-line depends on the losses in the EVT and the power converters:

- If the EVT and/or the power converters suffer from a poor efficiency, it is not desirable to send power to the MGs and consequently, the EVT transmission ratio remains unity (i.e. $\zeta = 1$).
- If the EVT and the power converters do have a good efficiency, it is profitable to change the transmission ratio by means of power from the MGs and bring the ICE towards the e-line.

These extreme values are visualized in Fig. 7, where point *A* depicts the situation with zero efficiency, and point *B* refers to an efficiency of 100% for both EVT and power converters.

In practical situations, however, losses will always be present and point *A* moves towards the e-line, but augmented by power losses, extra power is requested from the ICE. There exists an optimal point *C* where the engine has minimal fuel consumption for a given power demand to the wheels, see Fig. 7.

The corresponding transmission ratio ζ^* is found by formulating an optimization problem, where the objective function represents the engine fuel consumption:

$$\zeta^* = \arg \left[\min_{\zeta} F(P_{m1}) \right]. \quad (14)$$

Since it was assumed that there is no battery present in the system, P_e equals zero and the model from Section II can be used to calculate P_{m1} as function of P_{m2} and ζ . Finally, the corresponding fuel consumption is calculated from (12). Although this is a non-linear optimization problem, it still can be efficiently solved using numerical methods.

B. EVT with Energy Storage/Retrieval

Besides the transmission ratio, the EVT also offers freedom to exchange energy with the battery storage system. This

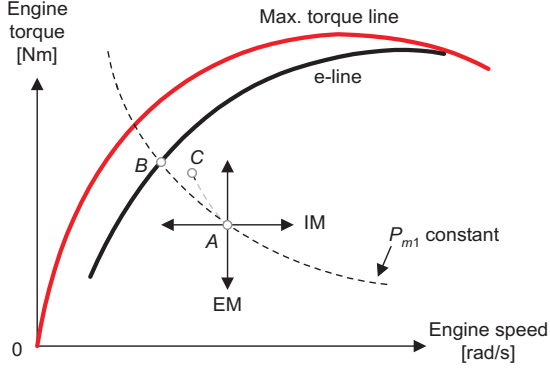

Fig. 7. ICE operating point optimization

second degree of freedom has also to be considered for IPC.

For preliminary analysis it is first assumed that the EVT does not suffer from any losses (also neglect losses in the power electronics). For this particular case, the model (5)...(11) boils down to the following ideal powersplit:

$$P_{m1} = P_{m2} + P_e. \quad (15)$$

The efficiency of this ideal powersplit is not affected by ζ , since it only depends on power without further notice of speed and torque. Then it becomes obvious to operate the ICE exclusively on the e-line, requesting minimal fuel consumption for a given power demand. As a result, one degree of freedom of the EVT is eliminated and only the electric power P_e needs to be calculated.

Calculation of P_e is closely related to supervisory control strategies using optimal control theory [4], [5], [9]. The objective function describes the total fuel consumption over an arbitrary driving cycle with time length t_e :

$$J = \int_0^{t_e} F_{e-line}(P_{m1})dt = \int_0^{t_e} F_{e-line}(P_{m2} + P_e)dt. \quad (16)$$

This objective function is accompanied by constraints to include the physical limitations of all powertrain components. Furthermore, the battery State Of Energy (SOE) needs to be within boundaries at the end of the driving cycle, e.g. $SOE(0) = SOE(t_e)$. This guarantees a charge sustaining vehicle. The optimization problem under consideration can be written as:

$$\min_{P_e} J(P_e) \quad \text{subject to } SOE(0) = SOE(t_e). \quad (17)$$

Solution methods for this classical optimization problem can be found in [8], [9]. Basically, these methods rewrite the SOE constraint in terms of battery power P_e , with integral zero if there are no further battery losses:

$$SOE(0) = SOE(t_e) \Leftrightarrow \int_0^{t_e} P_e dt = 0. \quad (18)$$

Next, this new constraint is incorporated in the original objective function J by means of a Lagrange multiplier λ :

$$\min_{P_e} \left[\int_0^{t_e} F_{e-line}(P_{m2} + P_e)dt - \lambda \int_0^{t_e} P_e dt \right]. \quad (19)$$

Here, λ has dimension [J/J] and it denotes the fuel energy content required to store one Joule energy in the battery. In [7] it is described how λ can be estimated on-line. This reduces the complexity of (19) and instead of solving an optimization problem over the entire driving cycle, the integration over time can be omitted and an instantaneous optimization problem remains:

$$\hat{F} = \min_{P_e} [F_{e-line}(P_{m2} + P_e) - \lambda P_e]. \quad (20)$$

Up to know, the analysis considered no losses and the simplification in (15) will no longer be valid when losses are included. Nonetheless, a similar approach can still be applied and the IPC strategy then becomes:

$$\check{F} = \min_{\zeta, P_e} [F_{e-line}(P_{m2} + P_e) - \lambda P_e]. \quad (21)$$

Note that the optimization problem in (21) is extended with decision variable ζ . Owing to losses in the EVT and the power converters, the previous section has shown that it is not acceptable to keep the ICE permanently on the e-line and therefore the fuel map F with the complete engine operating range is included in the optimization problem.

Finally, engine stop/start needs also to be included in the energy management strategy. In case the ICE is turned off, $P_{m1} = 0$ and the battery provides the requested power P_{m2} . The equivalent fuel usage can be approximated with the same Lagrange multiplier:

$$\check{F}_0 = -\lambda P_e. \quad (22)$$

Deciding to stop/start the ICE is done according to the following heuristic rule:

If $\check{F} < \check{F}_0$
Then ICE = on: Apply solution from (21)
Else ICE = off: Battery provides all power demand
End

Altogether, an energy management strategy is now developed which optimizes the energy efficiency of the entire hybrid powertrain.

IV. SIMULATION RESULTS

A mid-sized vehicle configuration is selected for evaluating the energy management strategy from the previous section. To analyze the performance of this vehicle configuration, the New European Driving Cycle (NEDC) is selected. The corresponding mechanical power request P_{m2} [W] is calculated from the NEDC speed profile using a backward vehicle model:

$$P_{m2} = \omega_d \tau_d, \quad (23)$$

with torque τ_d [Nm] and speed ω_d [rad/s] calculated from the vehicle speed v [m/s]:

$$\tau_d = \left(m\dot{v} + \frac{1}{2}\rho C_d A_d v^2 + C_r m g \right) \frac{w_r}{f_r}, \quad (24)$$

$$\omega_d = v \frac{f_r}{w_r}. \quad (25)$$

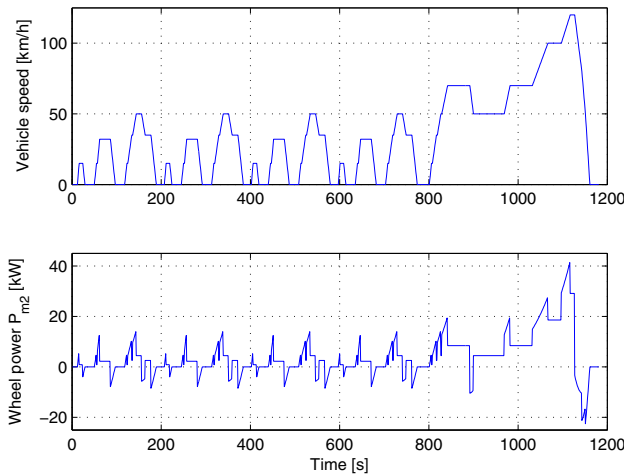

Fig. 8. Speed and power profile of New European Driving Cycle (NEDC)

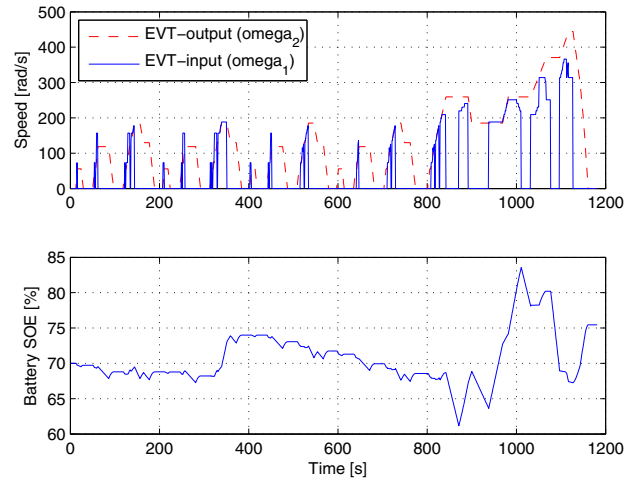

Fig. 9. EVT speed and battery State Of Energy (SOE)

TABLE I
PARAMETER LIST OF DRIVE TRAIN MODEL

Quantity	Symbol	Value	Unit
Vehicle mass	m	1400	kg
Frontal area	A_d	2.0	m ²
Air drag coefficient	C_d	0.3	-
Rolling resistance	C_r	0.0015	-
Air density	ρ	1.2	kg/m ³
Gravity	g	9.8	m/s ²
Wheel radius	w_r	0.3	m
Final drive ratio	f_r	4.0	-

A description of the parameters is given in Table I and the corresponding vehicle power demand is shown in Fig. 8. The vehicle is equipped with a 2.0ℓ gasoline ICE, naturally aspirated. Other characteristics of the powertrain are summarized in Table II.

The energy management strategy as described in Section III-B has been implemented, including a PI-controller for on-line estimation of λ , see [7]. In Fig. 9 one can see that the energy management strategy manages to keep the battery SOE near the preferred reference value $SOE_{ref} = 70$ [%].

Fig. 9 also reveals that the ICE is frequently switched off

TABLE II
CHARACTERISTICS POWERTRAIN COMPONENTS

Component	Value	Unit
Inner Motor (IM)		
Max. torque	90	Nm
Max. power	30	kW
External Motor (EM)		
Max. torque	220	Nm
Max. power	30	kW
Power converters		
Efficiency η_{c1}	0.96	-
Efficiency η_{c2}	0.96	-
Battery		
Battery capacity	4.0	MJ
Efficiency η_{bat}	0.81	-

during constant vehicle speed or deceleration phases. At these moments, the mechanical power demand is relatively low. Since the ICE exhibits poor efficiency at low power demand it is preferred to switch the ICE off in these areas. Nevertheless, considering other vehicle aspects such as driveability or durability (especially for the battery), it would be expedient to limit the number of ICE stops, with adverse effect on fuel economy. How to include these requirements in the energy management strategy will be a topic for further research.

Careful selection of the final drive ratio $f_r = 4.0$ [-] enables the energy management strategy to select frequently the preferred gear ratio $\zeta = 1.0$ for the EVT. This can be seen in Fig. 9, where the input speed of the EVT often equals its output speed. At vehicle speeds above 50 [km/h] the output speed typically exceeds the input speed, so the EVT operates in overdrive-mode, leading to recirculating power losses inside the EVT. This recirculating power can also be recognized in Fig. 10, e.g. during the interval $t \in [1031..1077]$. During this time period, the EM produces additional electric power which is directly consumed by the IM.

Optimizing the final drive ratio is a classical trade-off between fuel economy improvement versus driveability. A further reduction of the final drive ratio will improve fuel economy at higher vehicle speed by cutting down losses from recirculating power. However, at low vehicle speed the EVT transmission ratio can become larger than unity. Again recirculating power emerges, but this time the IM produces additional electric power whereas the EM consumes power for providing torque assist to the wheels. Additionally, due to a smaller final drive ratio, less maximum torque can be provided by the ICE which eventually leads to unacceptable performance for tracking the preferred speed profile.

The ICE operating points are visualized in Fig. 11. It can be seen that only few coinciding points exists with the e-line. Apparently, the fuel benefit for bringing the ICE on the e-line

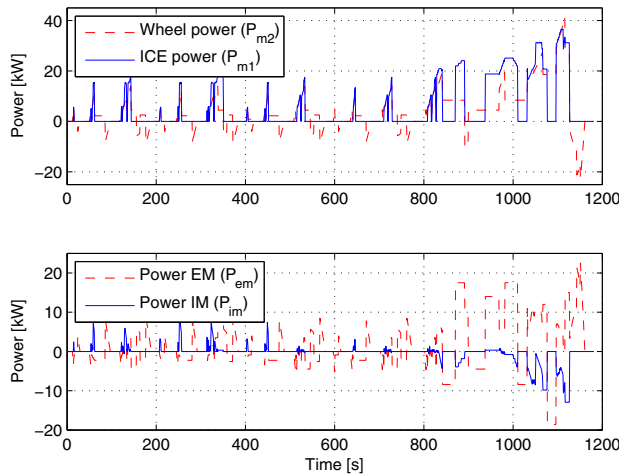

Fig. 10. Internal powerflow EVT

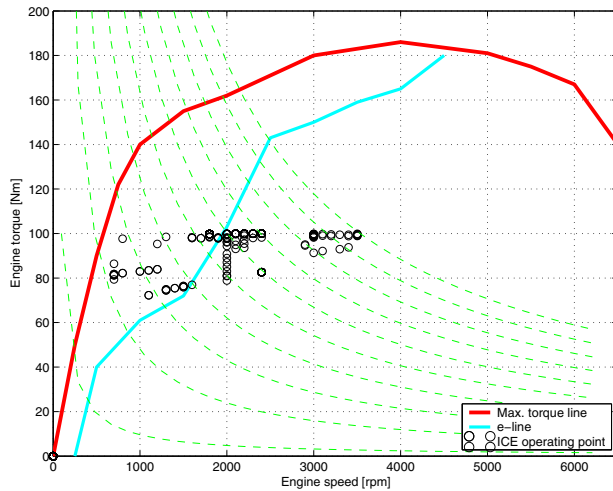

Fig. 11. Engine operating points

does not compensate for the additional transmission losses. Additional simulations learn that the operating points move closer to the e-line, when the efficiency of the EVT and the power converters increases. If also the battery efficiency can be improved, the energy management strategy eventually operates the ICE either in its sweet spot, or switch the ICE completely off.

V. CONCLUSIONS

Optimization of the vehicle powerflow by means of IPC takes into account the efficiency of all powertrain components, and results in maximum energy efficiency. A solution method is presented how to optimize the gear ratio of the EVT, as well as an on-line energy management strategy to control the hybrid functionality of the EVT.

Simulation results show that the EVT preferably selects transmission ratio $\zeta = 1$ to limit the transmission losses. The IPC strategy anticipates on the losses in the EVT and the electric power converters to obtain the highest overall powertrain efficiency. In the vehicle configuration under consideration, these losses are substantial, such that perfect e-line tracking is discouraged.

Altogether, the IPC strategy with the simulation environment offers an important tool for selecting and optimizing the total powertrain configuration.

ACKNOWLEDGEMENT

Part of this research is carried out within the European Community funded integrated project: Highly Integrated Combustion Electric Propulsion System (Hi-CEPS). The authors are very thankful for the support and feedback they received from Centro Ricerca Fiat (CRF), Vehicle Systems Group, concerning powertrain models and control strategies.

REFERENCES

- [1] Highly Integrated Combustion Electric Propulsion System (Hi-CEPS), www.hi-ceps.eu.
- [2] C.C. Chan. The state of the art of electric, hybrid, and fuel cell vehicles. *Proceedings of the IEEE*, 95(4):704–718, April 2007.
- [3] K.T. Chau and C.C. Chan. Emerging energy-efficient technologies for hybrid electric vehicles. *Proceedings of the IEEE*, 95(4):821–835, April 2007.
- [4] S. Delprat, J. Lauber, T.M. Guerra, and J. Rimaux. Control of a parallel hybrid powertrain: Optimal control. *IEEE Trans. on Vehicular Technology*, 53(3):872–881, May 2004.
- [5] L. Guzzella and A. Sciarretta. *Vehicle Propulsion Systems - Introduction to Modeling and Optimization*. Springer-Verlag, Berlin Heidelberg, 2005.
- [6] M.J. Hoeijmakers and J.A. Ferreira. The electric variable transmission. *IEEE Trans. on Industry Applications*, 42(4):1092–1100, July/August 2006.
- [7] J.T.B.A. Kessels, M. Koot, B. de Jager, P.P.J. van den Bosch, N.P.I. Aneke, and D.B. Kok. Energy management for the electric powertrain in vehicles with a conventional drivetrain. *IEEE Trans. on Control Systems Technology*, 15(3):494–505, May 2007.
- [8] J.T.B.A. Kessels, M.W.T. Koot, P.P.J. van den Bosch, and D.B. Kok. Online energy management for hybrid electric vehicles. *IEEE Trans. on Vehicular Technology*, 57(6):3428–3440, Nov 2008.
- [9] M. Koot, J.T.B.A. Kessels, B. de Jager, W.P.M.H. Heemels, P.P.J. van den Bosch, and M. Steinbuch. Energy management strategies for vehicular electric power systems. *IEEE Trans. on Vehicular Technology*, 54(3):771–782, May 2005.
- [10] J.M. Miller. Hybrid electric vehicle propulsion system architectures of the e-CVT type. *IEEE Trans. on Power Electronics*, 21(3):756–767, May 2006.
- [11] E. Nordlund and S. Eriksson. Test and verification of a four-quadrant transducer for hev applications. In *Proc. of the IEEE Vehicle Power and Propulsion Conference*, pages 37–41, Chicago, IL, September 2005.