

Wideband cancellation of second order intermodulation distortions in a 60-GHz zero-IF mixer

Citation for published version (APA):

Sakian Dezfuli, P., Mahmoudi, R., Heijden, van der, E., Graauw, de, A. J. M., & Roermund, van, A. (2011). Wideband cancellation of second order intermodulation distortions in a 60-GHz zero-IF mixer. In *IEEE proceeding of the 11th Topical Meeting on Silicon Monolithic Integrated Circuits in RF Systems (SiRF)*, lendale, AZ, USA, 17-19 Jan. 2011 (pp. 125-128). <https://doi.org/10.1109/SIRF.2011.5719311>

DOI:

[10.1109/SIRF.2011.5719311](https://doi.org/10.1109/SIRF.2011.5719311)

Document status and date:

Published: 01/01/2011

Document Version:

Publisher's PDF, also known as Version of Record (includes final page, issue and volume numbers)

Please check the document version of this publication:

- A submitted manuscript is the version of the article upon submission and before peer-review. There can be important differences between the submitted version and the official published version of record. People interested in the research are advised to contact the author for the final version of the publication, or visit the DOI to the publisher's website.
- The final author version and the galley proof are versions of the publication after peer review.
- The final published version features the final layout of the paper including the volume, issue and page numbers.

[Link to publication](#)

General rights

Copyright and moral rights for the publications made accessible in the public portal are retained by the authors and/or other copyright owners and it is a condition of accessing publications that users recognise and abide by the legal requirements associated with these rights.

- Users may download and print one copy of any publication from the public portal for the purpose of private study or research.
- You may not further distribute the material or use it for any profit-making activity or commercial gain
- You may freely distribute the URL identifying the publication in the public portal.

If the publication is distributed under the terms of Article 25fa of the Dutch Copyright Act, indicated by the "Taverne" license above, please follow below link for the End User Agreement:

www.tue.nl/taverne

Take down policy

If you believe that this document breaches copyright please contact us at:

openaccess@tue.nl

providing details and we will investigate your claim.

Wideband Cancellation of Second Order Intermodulation Distortions in a 60GHz Zero-IF Mixer

Pooyan Sakian[#], Reza Mahmoudi[#], Edwin van der Heijden^{*}, Anton de Graauw^{*}, and Arthur van Roermund[#]

[#]Electrical Engineering Department, Eindhoven University of Technology, the Netherlands

^{*}NXP Semiconductors, Eindhoven, the Netherlands

Abstract — The 1GHz target IF bandwidth of 60GHz zero-IF mixers makes conventional single- and double-parameter tuning methods ineffective for suppression of second-order intermodulation distortions across the whole IF band. In this paper a three-dimensional circuit parameter tuning method is used to address this problem. Output resistance, output capacitance, and gate biasing of the switching pairs are three parameters chosen for tuning. The mixer is designed and fabricated in CMOS 45nm technology. Measurement results show that the IMD2 tones across the whole 1GHz IF band can be suppressed simultaneously to within the noise level. The measured power conversion gain, IIP3 and typical corrected IIP2 of the mixer are 7dB, -7dBm and 27dBm, respectively.

Index Terms — Mixer, mm-wave, second-order intermodulation distortion, wideband, zero-IF.

I. INTRODUCTION

While offering the possibility of low-cost and compact solutions for receivers operating in the license-free band around 60GHz, zero-IF receiver architecture suffers from problems such as dc offset, flicker noise, and second order intermodulation distortions. The latest drafts of the IEEE802.15.3c standard set strict requirements on the linearity of 60GHz receivers [1]. Furthermore, tolerating the interfering signals, which may be very common after successful commercial proliferation of 60GHz transceivers, requires highly linear receivers.

Multi-Gbps applications envisioned for 60GHz band require around 1GHz of IF bandwidth. Therefore, any IMD2 cancelation mechanism applied to a 60GHz mixer must be functional across a wide frequency range. Narrowband IMD2 cancelation techniques, like conventional single-parameter and double-parameter tuning, are not beneficial since they suppress IMD2 at only one single frequency point [5]-[7].

In this paper a three-parameter tuning method is proposed and is shown both in theory and measurement to be effective in wideband cancelation of IMD2. In Section II the mechanisms responsible for IMD2 generation in a Gilbert-cell like mixer are explained. In Section III different methods of IMD2 cancelation are investigated and conditions for wideband functionality of these

methods are derived. In Section IV a circuit is proposed to implement and test the three-dimensional tuning method suggested in Section III. Section V presents the experimental and measurement results.

II. SECOND ORDER INTERMODULATION MECHANISMS

Downconversion mixer is normally the main contributor to second order nonlinearity distortions in a zero-IF receiver. The low-frequency second-order distortions generated in the RF path preceding the mixer can easily be filtered by RF coupling or band-pass filtering. Fig. 1 shows a typical Gilbert-cell-like mixer used in this study [2]. Input RF voltage is applied via two RF-coupling capacitors to the switching stage. The CL capacitors represent the input capacitance of the following stage as well as the parasitics of the switching transistors at the output node. The differential output IMD2 voltage ($V_{\text{imd2,out}}$), comes from two sources: 1) the common-mode output IMD2 current combined with output load mismatch and 2) the differential-mode output IMD2 current, as defined in (1) and (2) respectively.

$$I_{\text{imd2,CM}} = \frac{I_{\text{imd2,1}} + I_{\text{imd2,2}}}{2} \quad (1)$$

$$I_{\text{imd2,Diff}} = I_{\text{imd2,1}} - I_{\text{imd2,2}} \quad (2)$$

where, $I_{\text{imd2,1}}$ and $I_{\text{imd2,2}}$ are as shown in Fig. 1. The differential output IMD2 voltage is described as a function of these currents in (3).

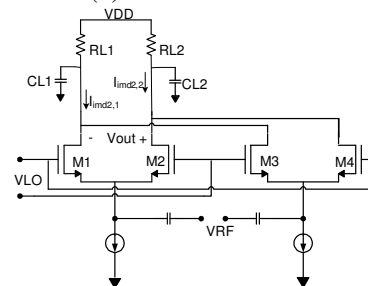

Fig. 1 The mixer used in this study

$$V_{imd2out} = I_{imd2,1}Z_{L,1} - I_{imd2,2}Z_{L,2} \quad (3)$$

where, $Z_{L,1}$ and $Z_{L,2}$ are the impedances seen from V_{out+} and V_{out-} nodes to the RF ground respectively as shown in (4).

$$Z_{Li} = \frac{R_{outi}}{1 + R_{outi}C_{Li}j\omega} \quad (4)$$

where, R_{out} is the resistance seen from the output node.

Defining a nominal value for output impedance as in (5), the differential output IMD2 voltage can be rewritten as a function of common-mode and differential-mode output IMD currents as depicted in (6).

$$\begin{aligned} Z_{L,1} &= Z_L(1 + \delta z_L) \\ Z_{L,2} &= Z_L(1 - \delta z_L) \end{aligned} \quad (5)$$

$$V_{imd2out} = 2I_{imd2CM}Z_L\delta z_L + I_{imd2Diff}Z_L \quad (6)$$

I_{imd2CM} is a function of the input-stage and switching stage even-order nonlinearities and is present at the output current even if there is no mismatch in the circuit. However, it can be vanished in the differential output voltage by a perfect matching between $Z_{L,1}$ and $Z_{L,2}$.

Three mechanisms are responsible for generation of $I_{imd2Diff}$: self-mixing, input stage nonlinearity combined with switching pair mismatches, and switching pair nonlinearity combined with its mismatches [3]. Self-mixing is a result of the leakage of RF signal to the LO and vice versa. It is in general a function of the layout parameters and can be activated by any kind of mismatch in the LO or RF paths. The contribution of the second and third mechanism is determined by the mismatch between transistors in the switching pair [3]. The mismatch between the two transistors in a differential pair can be represented by an equivalent voltage offset at the gate of one of them [4]:

$$V_{off} = \Delta V_T + \frac{\partial f}{\partial \beta} \Delta \beta + \frac{\partial f}{\partial \theta} \Delta \theta \quad (7)$$

$$f = \frac{\theta}{\beta} I_{DS} \left(1 + \sqrt{1 + \frac{2\beta}{\theta^2 I_{DS}}} \right) + V_T \quad (8)$$

where, I_{DS} is the biasing current of the transistor, $\beta = \mu_n C_{ox} W/L$, θ is the factor taking into account the velocity saturation effect, and V_T is the threshold voltage. Therefore, these mechanisms can only be activated if there is mismatch between the switching stage transistors. The effective mismatch between transistors can be controlled

by modifying the biasing voltage of the gates of transistors.

III. WIDEBAND IMD2 CANCELLATION

In this work it is assumed that the downconverted interfering signal at IF is wideband. However the interferer bandwidth is assumed small compared to its carrier frequency so that the interfering signal at RF can be considered as narrowband. Thus wideband IMD2 cancellation means that the IMD2 must be suppressed over the entire IF bandwidth.

$V_{imd2out}$ can be minimized by tuning different parameters. Single-parameter tuning methods can adjust V_{off} to vary $I_{imd2DIF}$ [5]. They can also adjust output resistance mismatches (δR_{out}) or output capacitance mismatches (δC_L) to vary δz_L [6]-[7]. To make the two terms in (6) cancel out each other by tuning only one parameter, the following should be satisfied:

$$\delta z_L = \frac{\delta R_{out} - R_{out}C_L\delta C_L j\omega_b}{(1 + R_{out}C_L j\omega_b)} = -\frac{I_{imd2Diff}}{2I_{imdCM}} \quad (9)$$

where, ω_b is the IMD2 frequency at the output of the mixer. Higher powers of δR_{out} and δC_L are neglected in this approximation of δz_L . However, choosing only one parameter to tune, can only satisfy (9) at one single frequency point, because for each frequency the tunable parameter has a different optimum.

Even a two-dimensional tuning involving δR_{out} and δC_L is not sufficient [7], because it can only set (6) to zero at a single frequency point.

The approach chosen in this work is tuning all three parameters at the same time. This will result in simultaneous nullification of both terms in (6) as shown in (10) and (11). Since both δR_{out} and δC_L are set to zero in this approach, nullification of δz_L is (ideally) frequency-independent. Due to narrowband assumption of interferer at RF, V_{off} can be chosen in a way that all three mechanisms responsible for $I_{imd2Diff}$ can cancel out each other.

$$\delta z_L = \frac{\delta R_{out} - R_{out}C_L\delta C_L j\omega_b}{(1 + R_{out}C_L j\omega_b)} = 0 \quad (10)$$

$$I_{imd2Diff}(V_{off}) = 0 \quad (11)$$

IV. CIRCUIT DESIGN

The circuit of Fig. 1 is modified to implement the three-dimensional tuning explained in Section III, resulting in a new circuit schematic as shown in Fig. 2. Variable

resistors and varactors are added to the output, to provide tunability of the output impedance as required by (10). Variable resistors are in the simple form of series transistors biased in the triode region. The biasing of the gates of the switching pair transistors is adjusted separately for each half-circuit as required by (11).

The circuit is designed and fabricated in CMOS 45nm technology. The supply voltage (VDD) is 1.1V. VR- and VR+, which control the value of the variable resistors, are differentially tuned around 100mV. VC- and VC+ control the varactors to tune the output capacitance and are differentially tuned around 500mV. VG- and VG+ tune the biasing voltage of the gate of switching pair transistors and are differentially tuned around 0.9V. The circuit draws less than 600 μ A from VDD. The complete chip includes the mixer core shown in Fig. 2 as well as two active baluns and matching networks at RF and LO inputs. In addition an IF buffer is used at the IF output to drive the 50 Ohm load of the measurement equipment.

V. MEASUREMENT AND EXPERIMENTAL RESULTS

To test the capability of IMD2 cancellation across a wide IF frequency range, a three-tone out-of-band signal is applied to the RF input of the mixer to emulate an out-of-band interferer. The three tones are at 61.07GHz, 61.130GHz, and 62.1GHz. The LO signal is at 60GHz. Therefore, the resulting IMD2 terms are at 60MHz and 970MHz which are measured as a function of the tuning parameters. There is another IMD2 term at 1030MHz which is considered as out-of-band and is not measured. The closest fundamental term of the downconverted interferer is at 1070MHz which is also measured as a function of tuning parameters to see how much the conversion gain can be affected by IMD2 cancellation. One of the IMD3 terms is also measured to observe the variation of IMD3 due to IMD2 cancellation.

Fig. 3 shows the variation of IMD2 when VR and VC are changed simultaneously while keeping VG equal to zero. VR is swept from -40mV to 40mV in steps of 0.5mV and in each step VC is swept from -300mV to 300mV in steps of 5mV. According to Fig. 3 IMD2 tones at 60 and 970MHz are never at the lowest points simultaneously, proving the inefficiency of two-dimensional tuning in this case. However as shown in Fig. 4 when VG is also tuned an optimum point can be found where both 60MHz and 970MHz IMD2 terms can be reduced to -70dBm. In this case three-dimensional tuning improves the IMD2 components at 60MHz and 970MHz by 10dBm and 20dBm respectively. Fig. 5 shows the measurements of another sample with two different interferer scenarios. First the IMD2 tones at 60MHz and 970MHz are generated as in Fig. 5(a). Then they are suppressed by

tuning as in Fig. 5(b). Afterwards, the interferer scenario is changed without changing the tuning to give two already suppressed IMD2 tones at 60MHz and 470MHz as in Fig. 5(d). Fig. 5(c) shows the IMD2 tones after removing the tuning. Measuring IMD3 and fundamental components during the sweeps reveals that the maximum variations of these terms occur when VG is varied. IMD3 and fundamental term are degraded by a maximum of 0.5dB and 1dB when VG is varied by ± 20 mV. The measured power conversion gain, IIP3 and typical corrected IIP2 of the mixer are 7dB, -7dBm and 27dBm respectively.

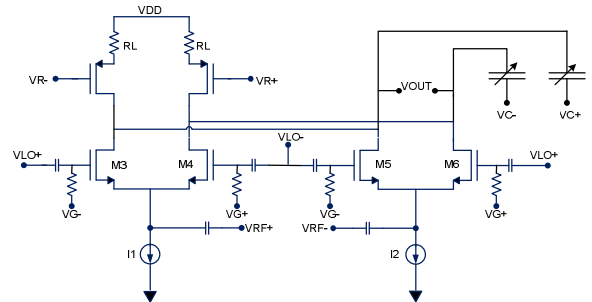

Fig. 2 Circuit schematic of the mixer with tunable output impedance and tunable gate biasing

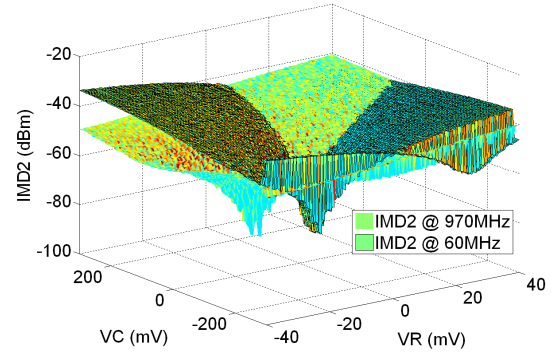

Fig. 3 IMD2 tuning by simultaneous variation of VC and VR while keeping VG constant at 0: wideband cancellation not possible

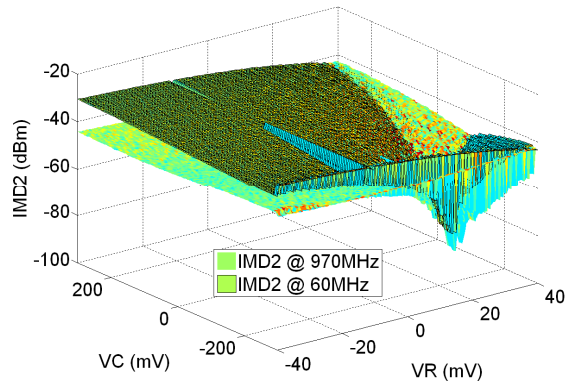

Fig. 4 IMD2 tuning by simultaneous variation of VC and VR while keeping VG constant at -10mV: wideband cancellation possible

VI. CONCLUSION

It is demonstrated both in theory and measurement that the presented three-dimensional tuning method is beneficial for wideband cancellation of second order intermodulation distortions (IMD2) in a zero-IF downconverter. The resistance and capacitance at the output of the mixer as well as the gate biasing of the switching pairs are the three parameters used for tuning. A 60GHz zero-IF mixer is designed and measured on-wafer to show that the proposed tuning mechanism can simultaneously suppress IMD2 tones across the whole 1GHz IF band while having minor effect on the conversion gain and third order intermodulation distortions.

REFERENCES

- [1] A. Tomkins, R. A. Aroca, T. Yamamoto, S. T. Nicolson, Y. Doi, and S. P. Voinescu, "A Zero-IF 60 GHz 65 nm CMOS Transceiver With Direct BPSK Modulation Demonstrating up to 6 Gb/s Data Rates Over a 2 m Wireless Link," *IEEE Journal of Solid State Circuits*, vol. 44, no. 8, pp. 2085-2099, August 2009.
- [2] P. Sakian, R. Mahmoudi, P. van Zeijl, M. Lont, and A. van Roermund, "A 60-GHz Double-Balanced Homodyne Down-Converter in 65-nm CMOS Process," *2009 European Microwave Integrated Circuits Conference*, Rome, September 2009.
- [3] D. Manstretta, M. Brandolini, and F. Svelto, "Second-Order Intermodulation Mechanisms in CMOS Downconverters," *IEEE Journal of Solid State Circuits*, vol. 38, no. 3, pp. 394-406, March 2003.
- [4] J. Wang, and A. K. K. Wong, "Effects of Mismatch on CMOS Double-Balanced Mixers: A Theoretical Analysis," *2001 IEEE Hong Kong Electron Devices Meeting*, Hong Kong, 2001.
- [5] K. Dufrene and R. Weigel, "A Novel IP2 Calibration Method for Low-Voltage Downconversion Mixers," *2006 IEEE Radio Frequency Integrated Circuits (RFIC) Symposium*, June 2006.
- [6] K. Kivekas, A. Parssinen, J. Ryyanen, J. Jussila, and K. Halonen, "Calibration Techniques of Active BiCMOS Mixers," *IEEE Journal of Solid State Circuits*, vol. 37, no. 6, pp. 766-769, June 2002.
- [7] M. Hotti, J. Ryyanen, K. Kivekas, and K. Halonen, "An IP2 Calibration Technique For Direct Conversion Receivers," *2004 IEEE International Symposium on Circuits and Systems (ISCAS)*, 2004.

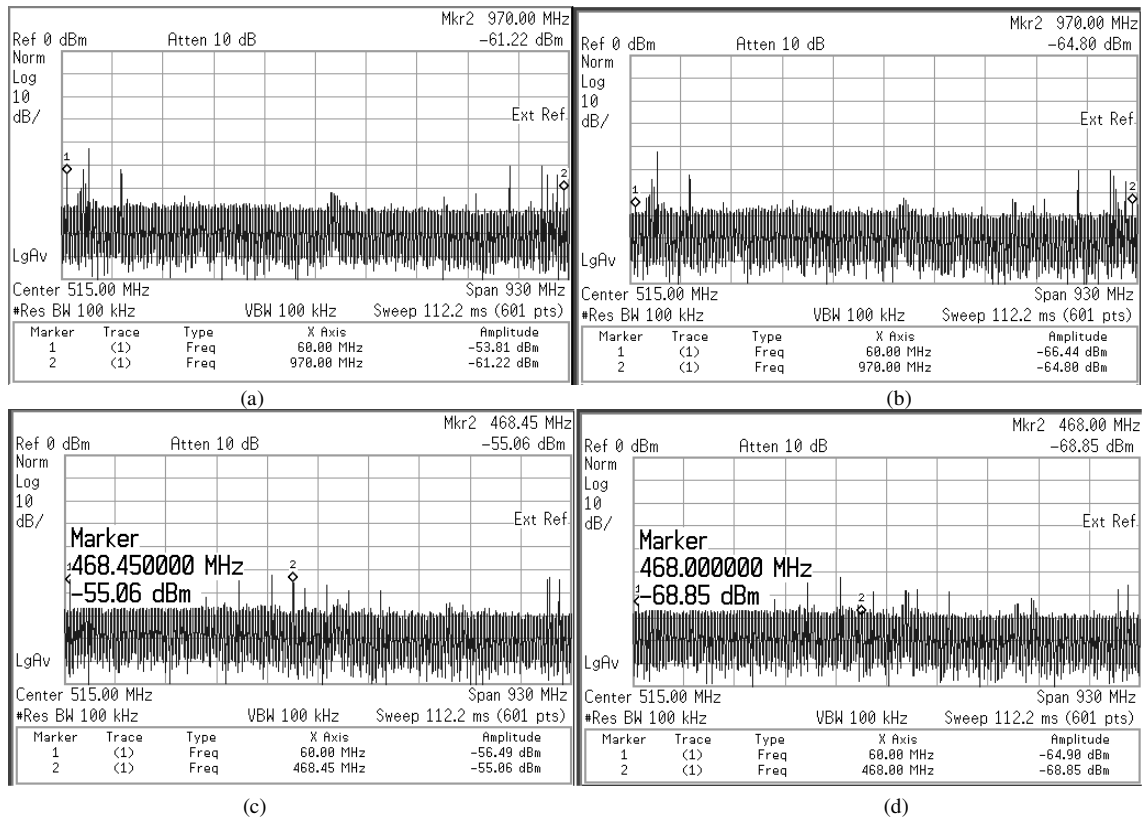

Fig. 5 Simultaneous suppression of IMD2 tones across the whole 1GHz IF band (shown by markers 1 and 2) at three exemplar points: a) without tuning: IMD2 tones at 60MHz and 970MHz, b) with tuning: IMD2 tones at 60MHz and 970MHz, c) without tuning: IMD2 tones at 60MHz and 470MHz, d) preserving the same tuning as in (b): IMD2 tones at 60MHz and 470MHz